

SN54AS286, SN74AS286 9-BIT PARITY GENERATORS/CHECKERS WITH BUS-DRIVER PARITY I/O PORT

SDAS050B – DECEMBER 1983 – REVISED DECEMBER 1994

- Generate Either Odd or Even Parity for Nine Data Lines
- Cascadable for n-Bit Parity
- Direct Bus Connection for Parity Generation or Checking by Using the Parity I/O Port
- Glitch-Free Bus During Power Up/Down
- Package Options Include Plastic Small-Outline (D) Packages, Ceramic Chip Carriers (FK), and Standard Plastic (N) and Ceramic (J) 300-mil DIPs

description

The SN54AS286 and SN74AS286 universal 9-bit parity generators/checkers feature a local output for parity checking and a 48-mA bus-driving parity input/output (I/O) port for parity generation/checking. The word-length capability is easily expanded by cascading.

The transmit ($\overline{\text{XMIT}}$) control input is implemented specifically to accommodate cascading. When $\overline{\text{XMIT}}$ is low, the parity tree is disabled and PARITY ERROR remains at a high logic level regardless of the input levels. When $\overline{\text{XMIT}}$ is high, the parity tree is enabled. PARITY ERROR indicates a parity error when either an even number of inputs (A–I) are high and PARITY I/O is forced to a low logic level, or when an odd number of inputs are high and PARITY I/O is forced to a high logic level.

The I/O control circuitry was designed so that the I/O port remains in the high-impedance state during power up or power down to prevent bus glitches.

The SN54AS286 is characterized for operation over the full military temperature range of -55°C to 125°C . The SN74AS286 is characterized for operation from 0°C to 70°C .

SN54AS286 . . . J PACKAGE
SN74AS286 . . . D OR N PACKAGE
(TOP VIEW)

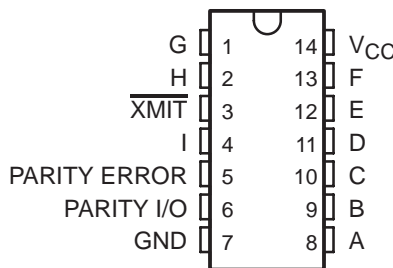

SN54AS286 . . . FK PACKAGE
(TOP VIEW)

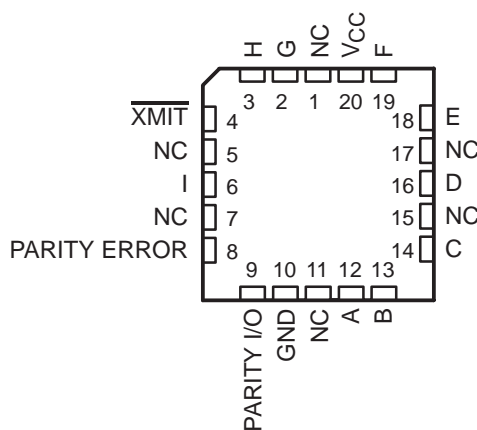

NC – No internal connection

FUNCTION TABLE

NUMBER OF INPUTS (A–I) THAT ARE HIGH	$\overline{\text{XMIT}}$	PARITY I/O	PARITY ERROR
0, 2, 4, 6, 8	l	H	H
1, 3, 5, 7, 9	l	L	H
0, 2, 4, 6, 8	h	h	H
	h	l	L
1, 3, 5, 7, 9	h	h	L
	h	l	H

h = high input level
H = high output level

l = low input level
L = low output level

SN54AS286, SN74AS286

9-BIT PARITY GENERATORS/CHECKERS

WITH BUS-DRIVER PARITY I/O PORT

SDAS050B - DECEMBER 1983 - REVISED DECEMBER 1994

logic symbol†

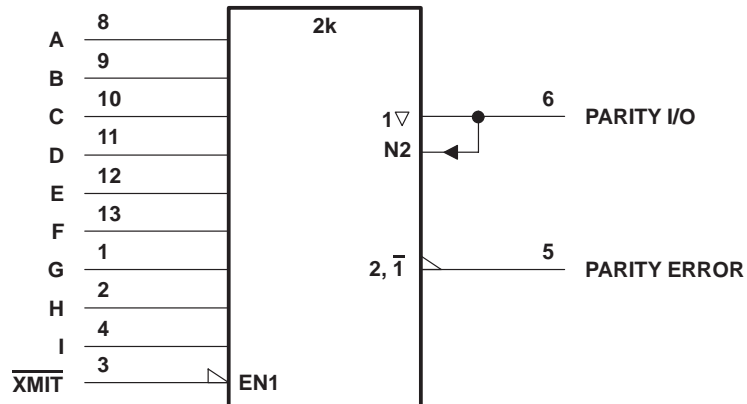

† This symbol is in accordance with ANSI/IEEE Std 91-1984 and IEC Publication 617-12. Pin numbers shown are for the D, J, and N packages.

logic diagram (positive logic)

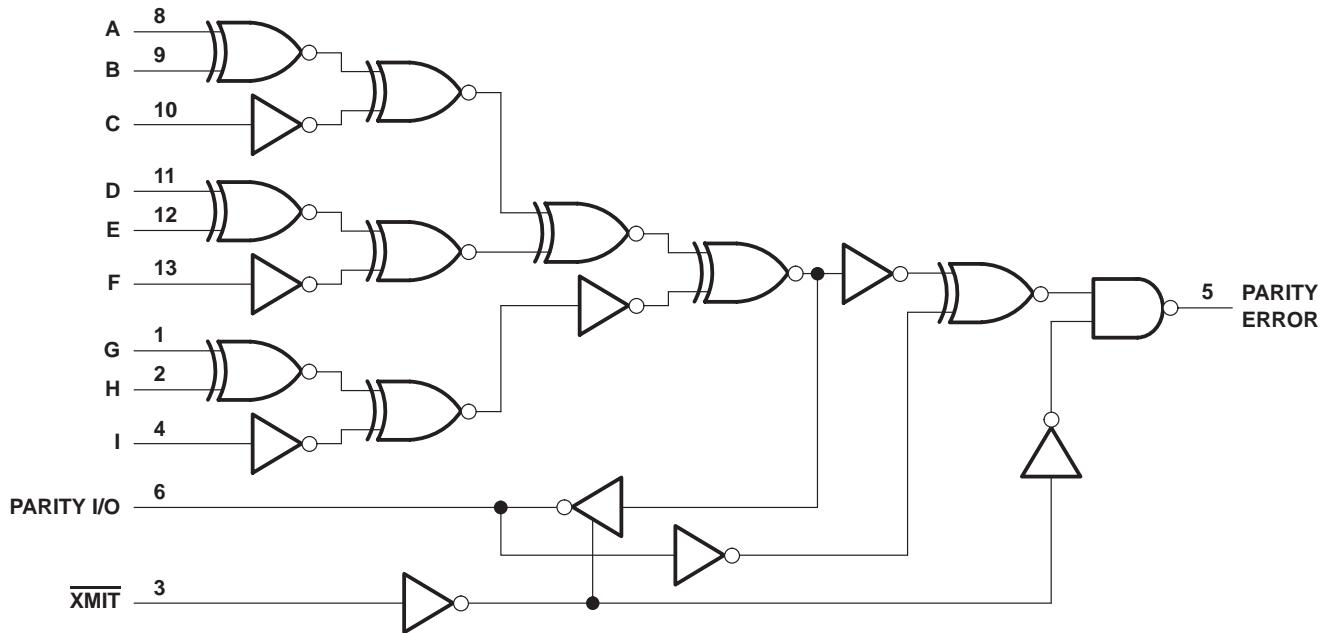

Pin numbers shown are for the D, J, and N packages.

SN54AS286, SN74AS286 9-BIT PARITY GENERATORS/CHECKERS WITH BUS-DRIVER PARITY I/O PORT

SDAS050B – DECEMBER 1983 – REVISED DECEMBER 1994

absolute maximum ratings over operating free-air temperature range (unless otherwise noted)†

Supply voltage, V_{CC}	7 V
Input voltage, V_I	7 V
Voltage applied to a disabled 3-state output	5.5 V
Operating free-air temperature range, T_A : SN54AS286	–55°C to 125°C
SN74AS286	0°C to 70°C
Storage temperature range	–65°C to 150°C

† Stresses beyond those listed under “absolute maximum ratings” may cause permanent damage to the device. These are stress ratings only, and functional operation of the device at these or any other conditions beyond those indicated under “recommended operating conditions” is not implied. Exposure to absolute-maximum-rated conditions for extended periods may affect device reliability.

recommended operating conditions

		SN54AS286			SN74AS286			UNIT
		MIN	NOM	MAX	MIN	NOM	MAX	
V_{CC}	Supply voltage	4.5	5	5.5	4.5	5	5.5	V
V_{IH}	High-level input voltage	2			2			V
V_{IL}	Low-level input voltage			0.8			0.8	V
I_{OH}	High-level output current	PARITY ERROR		–2	PARITY I/O		–2	mA
		PARITY I/O		–12	PARITY ERROR		–15	
I_{OL}	Low-level output current	PARITY ERROR		20	PARITY I/O		20	mA
		PARITY I/O		32	PARITY ERROR		48	
T_A	Operating free-air temperature	–55		125	0		70	°C

electrical characteristics over recommended operating free-air temperature range (unless otherwise noted)

PARAMETER		TEST CONDITIONS		SN54AS286			SN74AS286			UNIT	
				MIN	TYP‡	MAX	MIN	TYP‡	MAX		
V_{IK}		$V_{CC} = 4.5\text{ V}$,	$I_I = -18\text{ mA}$			–1.2			–1.2	V	
V_{OH}	All outputs	$V_{CC} = 4.5\text{ V to }5.5\text{ V}$,	$I_{OH} = -2\text{ mA}$	$V_{CC} - 2$		$V_{CC} - 2$				V	
	PARITY I/O	$V_{CC} = 4.5\text{ V}$	$I_{OH} = -3\text{ mA}$	2.4	2.9	2.4	3				
			$I_{OH} = -12\text{ mA}$	2.4							
V_{OL}	PARITY ERROR	$V_{CC} = 4.5\text{ V}$	$I_{OL} = 20\text{ mA}$	0.35	0.5	0.35	0.5			V	
	PARITY I/O		$I_{OL} = 32\text{ mA}$	0.5							
			$I_{OL} = 48\text{ mA}$					0.5			
I_I	PARITY I/O	$V_{CC} = 5.5\text{ V}$	$V_I = 5.5\text{ V}$			0.1			0.1	mA	
	All other inputs		$V_I = 7\text{ V}$			0.1			0.1		
I_{IH}	PARITY I/O§	$V_{CC} = 5.5\text{ V}$,	$V_I = 2.7\text{ V}$			50			50	µA	
	All other inputs					20			20		
I_{IL}	PARITY I/O§	$V_{CC} = 5.5\text{ V}$,	$V_I = 0.4\text{ V}$			–0.5			–0.5	mA	
	All other inputs					–0.5			–0.5		
I_{O}^{\parallel}		$V_{CC} = 5.5\text{ V}$,	$V_O = 2.25\text{ V}$	–30	–112	–30	–112			mA	
I_{CC}	Transmit	$V_{CC} = 5.5\text{ V}$			30	43	30	43			mA
	Receive				35	50	35	50			

‡ All typical values are at $V_{CC} = 5\text{ V}$, $T_A = 25^\circ\text{C}$.

§ For I/O ports, the parameters I_{IH} and I_{IL} include the off-state output current.

¶ The output conditions have been chosen to produce a current that closely approximates one half of the true short-circuit output current, I_{OS} .



SN54AS286, SN74AS286
9-BIT PARITY GENERATORS/CHECKERS
WITH BUS-DRIVER PARITY I/O PORT

SDAS050B – DECEMBER 1983 – REVISED DECEMBER 1994

switching characteristics (see Figure 3)

PARAMETER	FROM (INPUT)	TO (OUTPUT)	V _{CC} = 4.5 V to 5.5 V, C _L = 50 pF, R ₁ = 500 Ω, R ₂ = 500 Ω, T _A = MIN to MAX†				UNIT
			SN54AS286		SN74AS286		
			MIN	MAX	MIN	MAX	
t _{PLH}	Any A – I	PARITY I/O	3	17	3	15	ns
t _{PHL}			3	15	3	14	
t _{PLH}	Any A – I	PARITY ERROR	3	20	3	16.5	ns
t _{PHL}			3	18	3	16.5	
t _{PLH}	PARITY I/O	PARITY ERROR	3	10	3	9	ns
t _{PHL}			3	10	3	9	
t _{PZH}	\overline{XMIT}	PARITY I/O	3	14	3	13	ns
t _{PZL}			3	17	3	16	
t _{PHZ}	\overline{XMIT}	PARITY I/O	3	13	3	11.5	ns
t _{PLZ}			3	11	3	10	

† For conditions shown as MIN or MAX, use the appropriate value specified under recommended operating conditions.



APPLICATION INFORMATION

Figure 1 shows a 32-bit parity generator/checker with output polarity switching, parity-error detection, and parity on every byte.

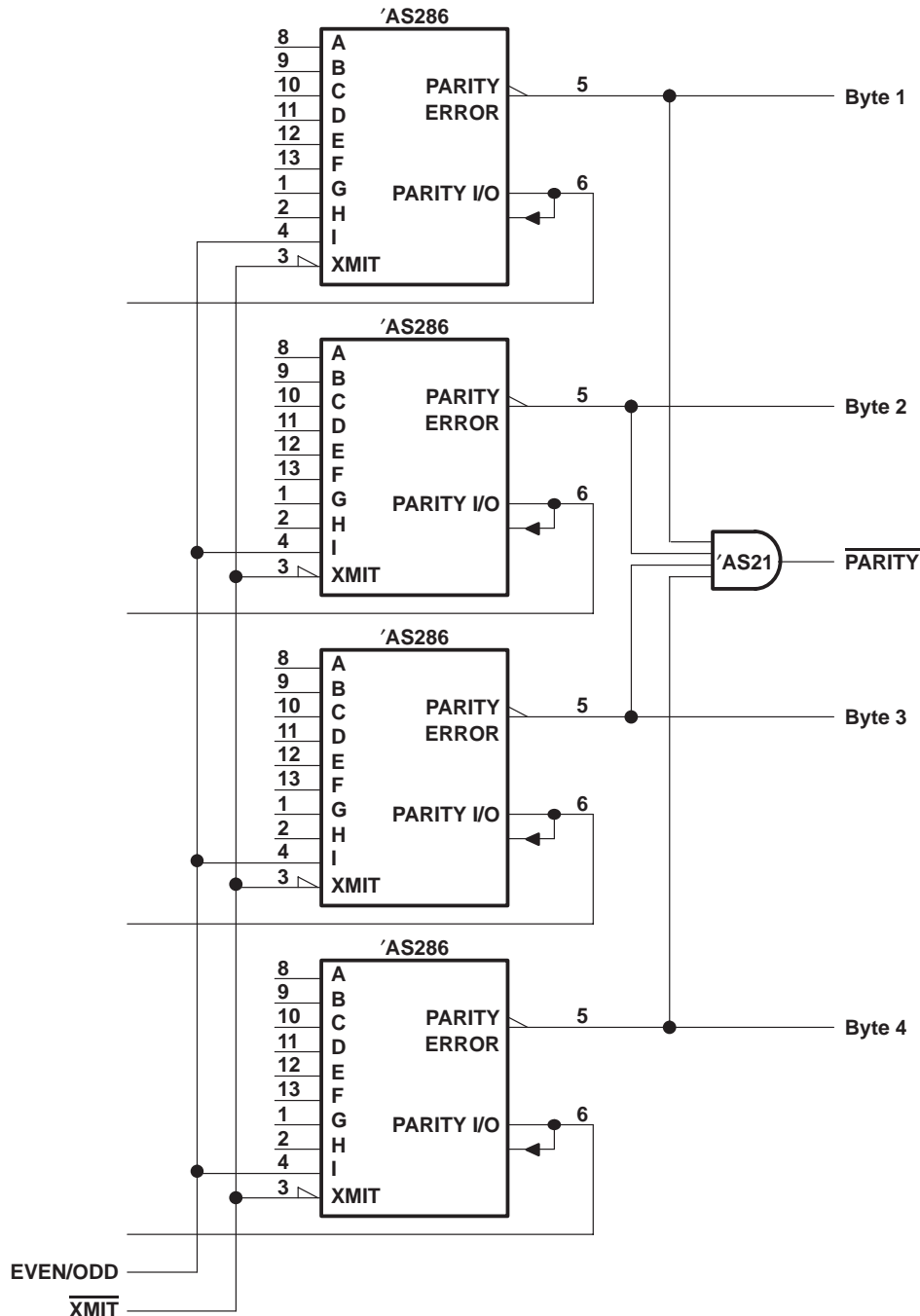

Pin numbers shown are for the D, J, and N packages.

Figure 1. 32-Bit Parity Generator/Checker

SN54AS286, SN74AS286

9-BIT PARITY GENERATORS/CHECKERS

WITH BUS-DRIVER PARITY I/O PORT

SDAS050B - DECEMBER 1983 - REVISED DECEMBER 1994

APPLICATION INFORMATION

Figure 2 shows a 90-bit parity generator/checker with $\overline{\text{XMIT}}$ on the last stage available for use with parity detection.

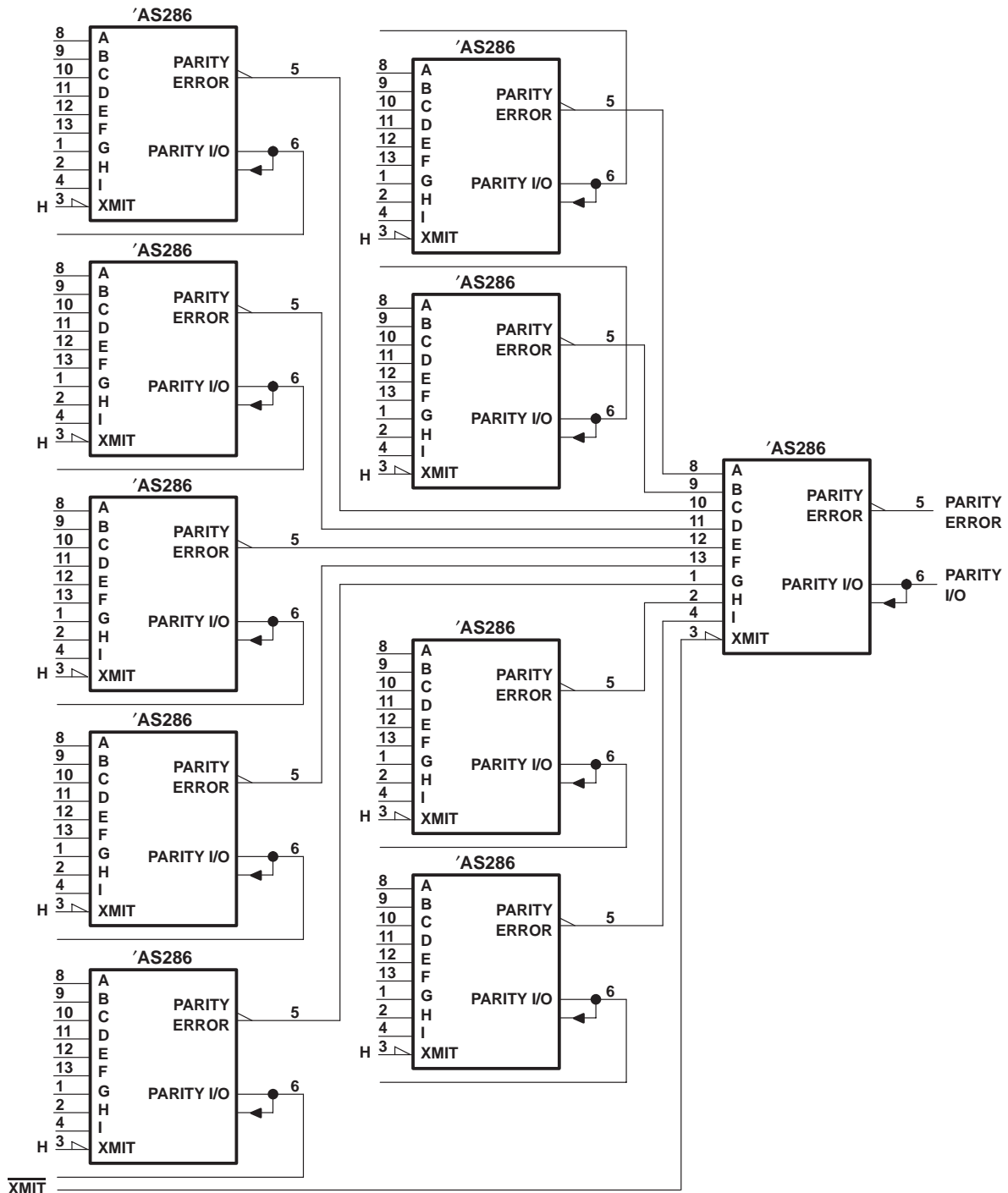

Pin numbers shown are for the D, J, and N packages.

Figure 2. 90-Bit Parity Generator/Checker With Parity-Error Detection





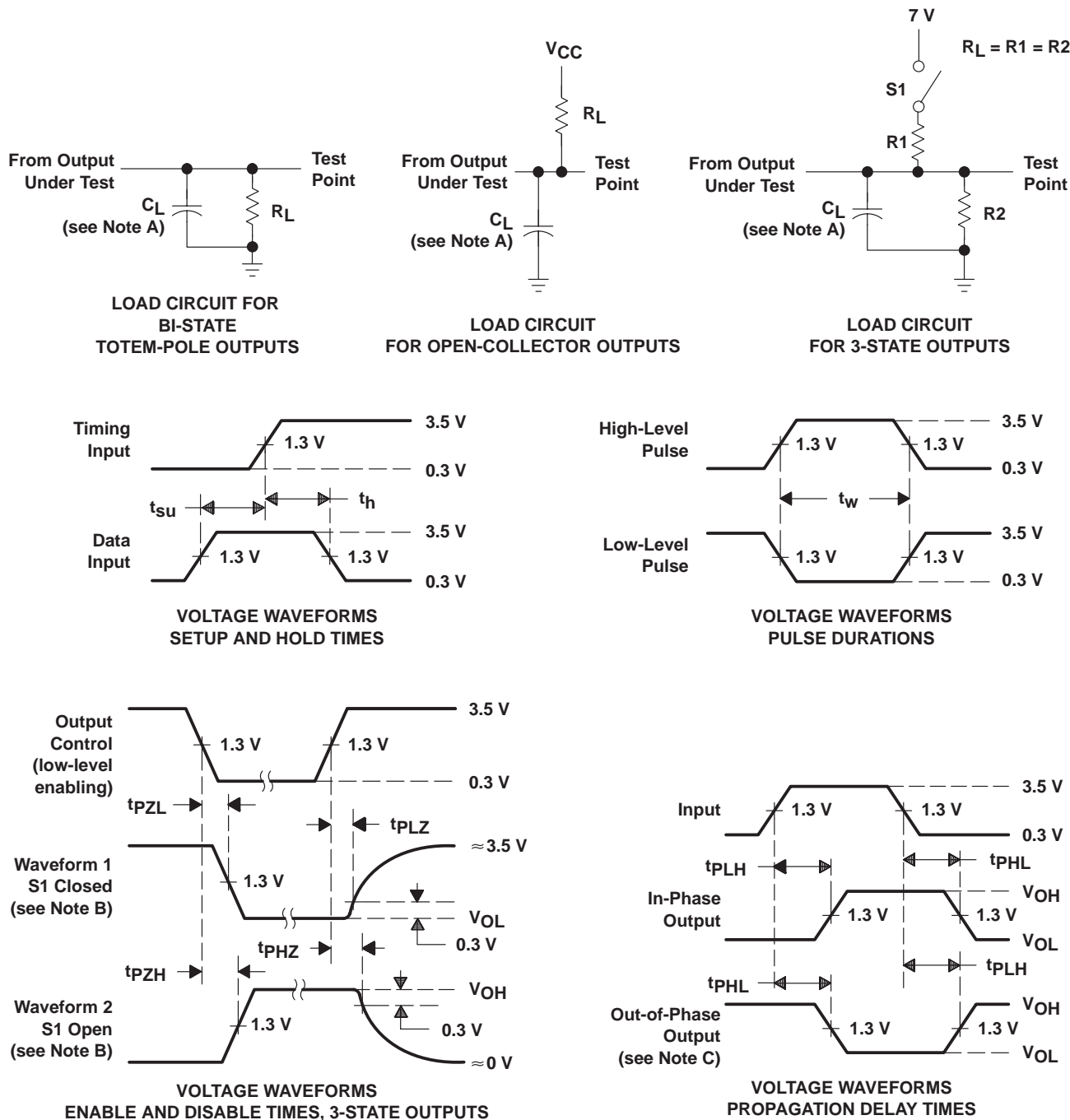

PARAMETER MEASUREMENT INFORMATION
SERIES 54ALS/74ALS AND 54AS/74AS DEVICES



- NOTES: A. C_L includes probe and jig capacitance.
 B. Waveform 1 is for an output with internal conditions such that the output is low except when disabled by the output control. Waveform 2 is for an output with internal conditions such that the output is high except when disabled by the output control.
 C. When measuring propagation delay items of 3-state outputs, switch S1 is open.
 D. All input pulses have the following characteristics: $PRR \leq 1$ MHz, $t_r = t_f = 2$ ns, duty cycle = 50%.
 E. The outputs are measured one at a time with one transition per measurement.

Figure 3. Load Circuits and Voltage Waveforms

PACKAGING INFORMATION

Orderable Device	Status (1)	Package Type	Package Drawing	Pins	Package Qty	Eco Plan (2)	Lead/Ball Finish (6)	MSL Peak Temp (3)	Op Temp (°C)	Device Marking (4/5)	Samples
5962-8966301CA	ACTIVE	CDIP	J	14		TBD	Call TI	Call TI	-55 to 125		
SN54AS286J	OBSOLETE	CDIP	J	14		TBD	Call TI	Call TI	-55 to 125		
SN74AS286D	ACTIVE	SOIC	D	14	50	Green (RoHS & no Sb/Br)	CU NIPDAU	Level-1-260C-UNLIM	0 to 70	AS286	
SN74AS286DR	OBSOLETE	SOIC	D	14		TBD	Call TI	Call TI	0 to 70		
SN74AS286DRE4	OBSOLETE	SOIC	D	14		TBD	Call TI	Call TI	0 to 70		
SN74AS286DRG4	OBSOLETE	SOIC	D	14		TBD	Call TI	Call TI	0 to 70		
SN74AS286N	ACTIVE	PDIP	N	14	25	Pb-Free (RoHS)	CU NIPDAU	N / A for Pkg Type	0 to 70	SN74AS286N	
SN74AS286NE4	ACTIVE	PDIP	N	14	25	Pb-Free (RoHS)	CU NIPDAU	N / A for Pkg Type	0 to 70	SN74AS286N	
SNJ54AS286FK	OBSOLETE	LCCC	FK	20		TBD	Call TI	Call TI	-55 to 125		

(1) The marketing status values are defined as follows:

ACTIVE: Product device recommended for new designs.

LIFEBUY: TI has announced that the device will be discontinued, and a lifetime-buy period is in effect.

NRND: Not recommended for new designs. Device is in production to support existing customers, but TI does not recommend using this part in a new design.

PREVIEW: Device has been announced but is not in production. Samples may or may not be available.

OBSOLETE: TI has discontinued the production of the device.

(2) Eco Plan - The planned eco-friendly classification: Pb-Free (RoHS), Pb-Free (RoHS Exempt), or Green (RoHS & no Sb/Br) - please check <http://www.ti.com/productcontent> for the latest availability information and additional product content details.

TBD: The Pb-Free/Green conversion plan has not been defined.

Pb-Free (RoHS): TI's terms "Lead-Free" or "Pb-Free" mean semiconductor products that are compatible with the current RoHS requirements for all 6 substances, including the requirement that lead not exceed 0.1% by weight in homogeneous materials. Where designed to be soldered at high temperatures, TI Pb-Free products are suitable for use in specified lead-free processes.

Pb-Free (RoHS Exempt): This component has a RoHS exemption for either 1) lead-based flip-chip solder bumps used between the die and package, or 2) lead-based die adhesive used between the die and leadframe. The component is otherwise considered Pb-Free (RoHS compatible) as defined above.

Green (RoHS & no Sb/Br): TI defines "Green" to mean Pb-Free (RoHS compatible), and free of Bromine (Br) and Antimony (Sb) based flame retardants (Br or Sb do not exceed 0.1% by weight in homogeneous material)

(3) MSL, Peak Temp. - The Moisture Sensitivity Level rating according to the JEDEC industry standard classifications, and peak solder temperature.

(4) There may be additional marking, which relates to the logo, the lot trace code information, or the environmental category on the device.

(5) Multiple Device Markings will be inside parentheses. Only one Device Marking contained in parentheses and separated by a "-" will appear on a device. If a line is indented then it is a continuation of the previous line and the two combined represent the entire Device Marking for that device.

(6) Lead/Ball Finish - Orderable Devices may have multiple material finish options. Finish options are separated by a vertical ruled line. Lead/Ball Finish values may wrap to two lines if the finish value exceeds the maximum column width.

Important Information and Disclaimer:The information provided on this page represents TI's knowledge and belief as of the date that it is provided. TI bases its knowledge and belief on information provided by third parties, and makes no representation or warranty as to the accuracy of such information. Efforts are underway to better integrate information from third parties. TI has taken and continues to take reasonable steps to provide representative and accurate information but may not have conducted destructive testing or chemical analysis on incoming materials and chemicals. TI and TI suppliers consider certain information to be proprietary, and thus CAS numbers and other limited information may not be available for release.

In no event shall TI's liability arising out of such information exceed the total purchase price of the TI part(s) at issue in this document sold by TI to Customer on an annual basis.

OTHER QUALIFIED VERSIONS OF SN54AS286, SN74AS286 :

- Catalog: [SN74AS286](#)
- Military: [SN54AS286](#)

NOTE: Qualified Version Definitions:

- Catalog - TI's standard catalog product
- Military - QML certified for Military and Defense Applications

J (R-GDIP-T**)

14 LEADS SHOWN

CERAMIC DUAL IN-LINE PACKAGE



DIM \ PINS **	14	16	18	20
A	0.300 (7,62) BSC	0.300 (7,62) BSC	0.300 (7,62) BSC	0.300 (7,62) BSC
B MAX	0.785 (19,94)	.840 (21,34)	0.960 (24,38)	1.060 (26,92)
B MIN	—	—	—	—
C MAX	0.300 (7,62)	0.300 (7,62)	0.310 (7,87)	0.300 (7,62)
C MIN	0.245 (6,22)	0.245 (6,22)	0.220 (5,59)	0.245 (6,22)



4040083/F 03/03

- NOTES:
- All linear dimensions are in inches (millimeters).
 - This drawing is subject to change without notice.
 - This package is hermetically sealed with a ceramic lid using glass frit.
 - Index point is provided on cap for terminal identification only on press ceramic glass frit seal only.
 - Falls within MIL STD 1835 GDIP1-T14, GDIP1-T16, GDIP1-T18 and GDIP1-T20.

FK (S-CQCC-N**)

LEADLESS CERAMIC CHIP CARRIER

28 TERMINAL SHOWN



NO. OF TERMINALS **	A		B	
	MIN	MAX	MIN	MAX
20	0.342 (8,69)	0.358 (9,09)	0.307 (7,80)	0.358 (9,09)
28	0.442 (11,23)	0.458 (11,63)	0.406 (10,31)	0.458 (11,63)
44	0.640 (16,26)	0.660 (16,76)	0.495 (12,58)	0.560 (14,22)
52	0.740 (18,78)	0.761 (19,32)	0.495 (12,58)	0.560 (14,22)
68	0.938 (23,83)	0.962 (24,43)	0.850 (21,6)	0.858 (21,8)
84	1.141 (28,99)	1.165 (29,59)	1.047 (26,6)	1.063 (27,0)



4040140/D 01/11

- NOTES:
- All linear dimensions are in inches (millimeters).
 - This drawing is subject to change without notice.
 - This package can be hermetically sealed with a metal lid.
 - Falls within JEDEC MS-004

N (R-PDIP-T**)

PLASTIC DUAL-IN-LINE PACKAGE

16 PINS SHOWN



- NOTES:
- A. All linear dimensions are in inches (millimeters).
 - B. This drawing is subject to change without notice.
 - $\triangle C$ Falls within JEDEC MS-001, except 18 and 20 pin minimum body length (Dim A).
 - $\triangle D$ The 20 pin end lead shoulder width is a vendor option, either half or full width.

4040049/E 12/2002

D (R-PDSO-G14)

PLASTIC SMALL OUTLINE



- NOTES:
- All linear dimensions are in millimeters.
 - This drawing is subject to change without notice.
 - Publication IPC-7351 is recommended for alternate designs.
 - Laser cutting apertures with trapezoidal walls and also rounding corners will offer better paste release. Customers should contact their board assembly site for stencil design recommendations. Refer to IPC-7525 for other stencil recommendations.
 - Customers should contact their board fabrication site for solder mask tolerances between and around signal pads.

IMPORTANT NOTICE

Texas Instruments Incorporated and its subsidiaries (TI) reserve the right to make corrections, enhancements, improvements and other changes to its semiconductor products and services per JESD46, latest issue, and to discontinue any product or service per JESD48, latest issue. Buyers should obtain the latest relevant information before placing orders and should verify that such information is current and complete. All semiconductor products (also referred to herein as "components") are sold subject to TI's terms and conditions of sale supplied at the time of order acknowledgment.

TI warrants performance of its components to the specifications applicable at the time of sale, in accordance with the warranty in TI's terms and conditions of sale of semiconductor products. Testing and other quality control techniques are used to the extent TI deems necessary to support this warranty. Except where mandated by applicable law, testing of all parameters of each component is not necessarily performed.

TI assumes no liability for applications assistance or the design of Buyers' products. Buyers are responsible for their products and applications using TI components. To minimize the risks associated with Buyers' products and applications, Buyers should provide adequate design and operating safeguards.

TI does not warrant or represent that any license, either express or implied, is granted under any patent right, copyright, mask work right, or other intellectual property right relating to any combination, machine, or process in which TI components or services are used. Information published by TI regarding third-party products or services does not constitute a license to use such products or services or a warranty or endorsement thereof. Use of such information may require a license from a third party under the patents or other intellectual property of the third party, or a license from TI under the patents or other intellectual property of TI.

Reproduction of significant portions of TI information in TI data books or data sheets is permissible only if reproduction is without alteration and is accompanied by all associated warranties, conditions, limitations, and notices. TI is not responsible or liable for such altered documentation. Information of third parties may be subject to additional restrictions.

Resale of TI components or services with statements different from or beyond the parameters stated by TI for that component or service voids all express and any implied warranties for the associated TI component or service and is an unfair and deceptive business practice. TI is not responsible or liable for any such statements.

Buyer acknowledges and agrees that it is solely responsible for compliance with all legal, regulatory and safety-related requirements concerning its products, and any use of TI components in its applications, notwithstanding any applications-related information or support that may be provided by TI. Buyer represents and agrees that it has all the necessary expertise to create and implement safeguards which anticipate dangerous consequences of failures, monitor failures and their consequences, lessen the likelihood of failures that might cause harm and take appropriate remedial actions. Buyer will fully indemnify TI and its representatives against any damages arising out of the use of any TI components in safety-critical applications.

In some cases, TI components may be promoted specifically to facilitate safety-related applications. With such components, TI's goal is to help enable customers to design and create their own end-product solutions that meet applicable functional safety standards and requirements. Nonetheless, such components are subject to these terms.

No TI components are authorized for use in FDA Class III (or similar life-critical medical equipment) unless authorized officers of the parties have executed a special agreement specifically governing such use.

Only those TI components which TI has specifically designated as military grade or "enhanced plastic" are designed and intended for use in military/aerospace applications or environments. Buyer acknowledges and agrees that any military or aerospace use of TI components which have **not** been so designated is solely at the Buyer's risk, and that Buyer is solely responsible for compliance with all legal and regulatory requirements in connection with such use.

TI has specifically designated certain components as meeting ISO/TS16949 requirements, mainly for automotive use. In any case of use of non-designated products, TI will not be responsible for any failure to meet ISO/TS16949.

Products

Audio	www.ti.com/audio
Amplifiers	amplifier.ti.com
Data Converters	dataconverter.ti.com
DLP® Products	www.dlp.com
DSP	dsp.ti.com
Clocks and Timers	www.ti.com/clocks
Interface	interface.ti.com
Logic	logic.ti.com
Power Mgmt	power.ti.com
Microcontrollers	microcontroller.ti.com
RFID	www.ti-rfid.com
OMAP Applications Processors	www.ti.com/omap
Wireless Connectivity	www.ti.com/wirelessconnectivity

Applications

Automotive and Transportation	www.ti.com/automotive
Communications and Telecom	www.ti.com/communications
Computers and Peripherals	www.ti.com/computers
Consumer Electronics	www.ti.com/consumer-apps
Energy and Lighting	www.ti.com/energy
Industrial	www.ti.com/industrial
Medical	www.ti.com/medical
Security	www.ti.com/security
Space, Avionics and Defense	www.ti.com/space-avionics-defense
Video and Imaging	www.ti.com/video

TI E2E Community

e2e.ti.com