

## FEATURES

- Provides Bidirectional Voltage Translation With No Direction Control Required
- Allows Voltage Level Translation From 1 V up to 5 V
- Provides Direct Interface With GTL, GTL+, LVTTTL/TTL, and 5-V CMOS Levels
- Low On-State Resistance Between Input and Output Pins (Sn/Dn)
- Supports Hot Insertion
- No Power Supply Required – Will Not Latch Up
- 5-V-Tolerant Inputs
- Low Standby Current
- Flow-Through Pinout for Ease of Printed Circuit Board Trace Routing
- ESD Protection Exceeds JESD 22
  - 2000-V Human-Body Model (A114-4)
  - 1000-V Charged-Device Model (C101)

PW PACKAGE  
(TOP VIEW)

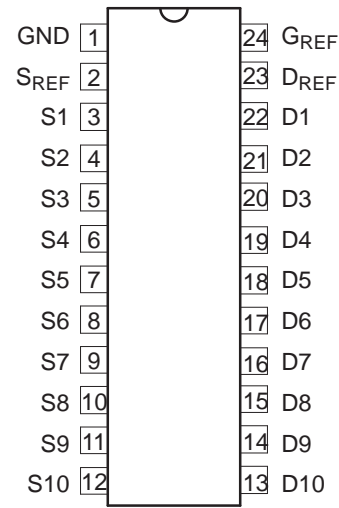

## APPLICATIONS

- Bidirectional or Unidirectional Applications Requiring Voltage-Level Translation From Any Voltage (1 V to 5 V) to Any Voltage (1 V to 5 V)
- Low Voltage Processor I<sup>2</sup>C Port Translation to 3.3-V and/or 5-V I<sup>2</sup>C Bus Signal Levels
- GTL/GTL+ Translation to LVTTTL/TTL Signal Levels

## DESCRIPTION/ORDERING INFORMATION

The GTL2010 provides ten NMOS pass transistors (Sn and Dn) with a common gate (G<sub>REF</sub>) and a reference transistor (S<sub>REF</sub> and D<sub>REF</sub>). The low ON-state resistance of the switch allows connections to be made with minimal propagation delay. With no direction control pin required, the device allows bidirectional voltage translations any voltage (1 V to 5 V) to any voltage (1 V to 5 V).

When the Sn or Dn port is LOW, the clamp is in the ON state and a low-resistance connection exists between the Sn and Dn ports. Assuming the higher voltage is on the Dn port, when the Dn port is HIGH, the voltage on the Sn port is limited to the voltage set by the reference transistor (S<sub>REF</sub>). When the Sn port is HIGH, the Dn port is pulled to V<sub>CC</sub> by the pullup resistors.



Please be aware that an important notice concerning availability, standard warranty, and use in critical applications of Texas Instruments semiconductor products and disclaimers thereto appears at the end of this data sheet.

## DESCRIPTION/ORDERING INFORMATION (CONTINUED)

All transistors in the GTL2010 have the same electrical characteristics, and there is minimal deviation from one output to another in voltage or propagation delay. This offers superior matching over discrete transistor voltage-translation solutions where the fabrication of the transistors is not symmetrical. With all transistors being identical, the reference transistor ( $S_{REF}/D_{REF}$ ) can be located on any of the other ten matched  $S_n/D_n$  transistors, allowing for easier board layout. The translator transistors with integrated ESD circuitry provides excellent ESD protection.

### ORDERING INFORMATION

$T_A$	PACKAGE <sup>(1)</sup>		ORDERABLE PART NUMBER	TOP-SIDE MARKING
-40°C to 85°C	TSSOP – PW	Tape and reel	SN74GTL2010PWR	GK2010

(1) Package drawings, standard packing quantities, thermal data, symbolization, and PCB design guidelines are available at [www.ti.com/sc/package](http://www.ti.com/sc/package).

### PIN DESCRIPTION

PIN NO.	NAME	DESCRIPTION
1	GND	Ground (0 V)
2	$S_{REF}$	Source of reference transistor
3–12	$S_n$	Ports S1–10
13–22	$D_n$	Ports D10–D1
23	$D_{REF}$	Drain of reference transistor
24	$G_{REF}$	Gate of reference transistor

FUNCTION TABLES<sup>(1)</sup>

HIGH-to-LOW Translation (Assuming Dn is at the Higher Voltage Level)

G <sub>REF</sub> <sup>(2)</sup>	D <sub>REF</sub>	S <sub>REF</sub>	INPUTS D10–D1	OUTPUTS S10–S1	TRANSISTOR
H	H	0 V	X	X	Off
H	H	V <sub>TT</sub> <sup>(3)</sup>	H	V <sub>TT</sub> <sup>(4)</sup>	On
H	H	V <sub>TT</sub>	L	L <sup>(5)</sup>	On
L	L	0 – V <sub>TT</sub>	X	X	Off

- (1) H = HIGH voltage level, L = LOW voltage level, X = don't care
- (2) G<sub>REF</sub> should be at least 1.5 V higher than S<sub>REF</sub> for best translator operation.
- (3) V<sub>TT</sub> is equal to the S<sub>REF</sub> voltage.
- (4) Sn is not pulled up or pulled down.
- (5) Sn follows the Dn input LOW.

LOW-to-HIGH Translation (Assuming Dn is at the Higher Voltage Level)<sup>(1)</sup>

G <sub>REF</sub> <sup>(2)</sup>	D <sub>REF</sub>	S <sub>REF</sub>	INPUTS D10–D1	OUTPUTS S10–S1	TRANSISTOR
H	H	0 V	X	X	Off
H	H	V <sub>TT</sub> <sup>(3)</sup>	V <sub>TT</sub>	H <sup>(4)</sup>	Nearly off
H	H	V <sub>TT</sub>	L	L <sup>(5)</sup>	On
L	L	0 – V <sub>TT</sub>	X	X	Off

- (1) H = HIGH voltage level, L = LOW voltage level, X = don't care
- (2) G<sub>REF</sub> should be at least 1.5 V higher than S<sub>REF</sub> for best translator operation.
- (3) V<sub>TT</sub> is equal to the S<sub>REF</sub> voltage.
- (4) Dn is pulled up to V<sub>CC</sub> through an external resistor.
- (5) Dn follows the Sn input LOW.

CLAMP SCHEMATIC

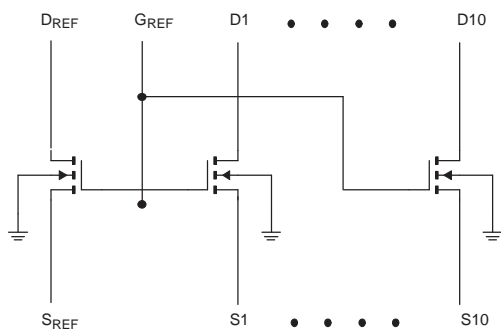

SA00647

# GTL2010

## 10-BIT BIDIRECTIONAL LOW-VOLTAGE TRANSLATOR

SCDS221 – SEPTEMBER 2006

### Absolute Maximum Ratings<sup>(1)(2)(3)</sup>

		MIN	MAX	UNIT
V <sub>SREF</sub>	DC source reference voltage	-0.5	7	V
V <sub>DREF</sub>	DC drain reference voltage	-0.5	7	V
V <sub>GREF</sub>	DC gate reference voltage	-0.5	7	V
V <sub>Sn</sub>	DC voltage port Sn	-0.5	7	V
V <sub>Dn</sub>	DC voltage port Dn	-0.5	7	V
I <sub>REFK</sub>	DC diode current on reference pins	V <sub>I</sub> < 0 V	-50	mA
I <sub>SK</sub>	DC diode current port Sn	V <sub>I</sub> < 0 V	-50	mA
I <sub>DK</sub>	DC diode current port Dn	V <sub>I</sub> < 0 V	-50	mA
I <sub>MAX</sub>	DC clamp current per channel	Channel in ON state	±128	mA
θ <sub>JA</sub>	Package thermal impedance		88	°C/W
T <sub>stg</sub>	Storage temperature range	-65	150	°C

- (1) Stresses beyond those listed under "absolute maximum ratings" may cause permanent damage to the device. These are stress ratings only, and functional operation of the device at these or any other conditions beyond those indicated under "recommended operating conditions" is not implied. Exposure to absolute-maximum-rated conditions for extended periods may affect device reliability.
- (2) The performance capability of a high-performance integrated circuit in conjunction with its thermal environment can create junction temperatures that are detrimental to reliability. The maximum junction temperature of this integrated circuit should not exceed 150°C.
- (3) The input and output negative voltage ratings may be exceeded if the input and output clamp current ratings are observed.

### Recommended Operating Conditions

		MIN	MAX	UNIT
V <sub>I/O</sub>	Input/output voltage (Sn, Dn)	0	5.5	V
V <sub>SREF</sub>	DC source reference voltage <sup>(1)</sup>	0	5.5	V
V <sub>DREF</sub>	DC drain reference voltage	0	5.5	V
V <sub>GREF</sub>	DC gate reference voltage	0	5.5	V
I <sub>PASS</sub>	Pass transistor current		64	mA
T <sub>amb</sub>	Operating ambient temperature range (in free air)	-40	85	°C

- (1) V<sub>SREF</sub> = V<sub>DREF</sub> - 1.5 V for best results in level-shifting applications.

**Electrical Characteristics**

over recommended operating free-air temperature range (unless otherwise noted)

PARAMETER		TEST CONDITIONS		MIN	TYP <sup>(1)</sup>	MAX	UNIT
$V_{OL}$	Low-level output voltage	$V_{DD} = 3\text{ V}$ , $V_{SREF} = 1.365\text{ V}$ , $V_{Sn}$ or $V_{Dn} = 0.175\text{ V}$ , $I_{clamp} = 15.2\text{ mA}$			260	350	mV
$V_{IK}$	Input clamp voltage	$I_I = -18\text{ mA}$ ,	$V_{GREF} = 0\text{ V}$			-1.2	V
$I_{IH}$	Gate input leakage	$V_I = 5\text{ V}$ ,	$V_{GREF} = 0\text{ V}$			5	$\mu\text{A}$
$C_{I(GREF)}$	Gate capacitance	$V_I = 3\text{ V}$ or $0\text{ V}$			56		pF
$C_{IO(OFF)}$	OFF capacitance	$V_O = 3\text{ V}$ or $0\text{ V}$ ,	$V_{GREF} = 0\text{ V}$		7.4		pF
$C_{IO(ON)}$	ON capacitance	$V_O = 3\text{ V}$ or $0\text{ V}$ ,	$V_{GREF} = 3\text{ V}$		18.6		pF
$r_{on}^{(2)}$	ON-state resistance	$V_I = 0\text{ V}$	$V_{GREF} = 4.5\text{ V}$	$I_O = 64\text{ mA}$	3.5	5	$\Omega$
			$V_{GREF} = 3\text{ V}$		4.4	7	
			$V_{GREF} = 2.3\text{ V}$		5.5	9	
			$V_{GREF} = 1.5\text{ V}$		67	105	
			$V_{GREF} = 1.5\text{ V}$ ,		$I_O = 30\text{ mA}$	9	
		$V_I = 2.4\text{ V}$	$V_{GREF} = 4.5\text{ V}$	$I_O = 15\text{ mA}$	7	10	
			$V_{GREF} = 3\text{ V}$		58	80	
			$V_{GREF} = 2.3\text{ V}$		50	70	

 (1) All typical values are measured at  $T_{amb} = 25^\circ\text{C}$ .

(2) Measured by the voltage drop between the Sn and the Dn terminals at the indicated current through the switch. On-state resistance is determined by the lowest voltage of the two (Sn or Dn) terminals.

**AC Characteristics for Translator-Type Applications<sup>(1)</sup>**

$V_{REF} = 1.365\text{ V to }1.635\text{ V}$ ,  $V_{DD1} = 3\text{ V to }3.6\text{ V}$ ,  $V_{DD2} = 2.36\text{ V to }2.64\text{ V}$ ,  $GND = 0\text{ V}$ ,  $t_r = t_f \leq 3\text{ ns}$ ,  $T_{amb} = -40^\circ\text{C to }85^\circ\text{C}$   
 (see Figure 5)

PARAMETER		MIN	TYP <sup>(2)</sup>	MAX	UNIT
$t_{PLH}$ <sup>(3)</sup>	Propagation delay (Sn to Dn, Dn to Sn)	0.5	1.5	5.5	ns

- (1)  $C_{ON(max)}$  of 30 pF and a  $C_{OFF(max)}$  of 15 pF is specified by design.
- (2) All typical values are measured at  $V_{DD1} = 3.3\text{ V}$ ,  $V_{DD2} = 2.5\text{ V}$ ,  $V_{REF} = 1.5\text{ V}$  and  $T_{amb} = 25^\circ\text{C}$ .
- (3) Propagation delay specified by characterization.

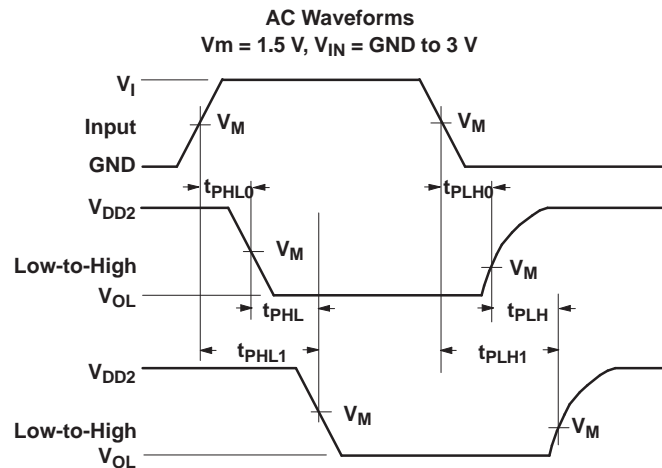

**Figure 1. Input (Sn) to Output (Dn) Propagation Delays**

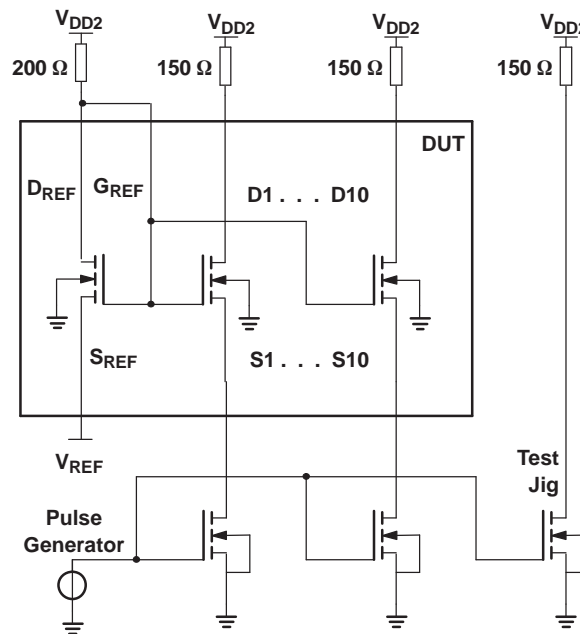

**Figure 2. Load Circuit**

**AC Characteristics for CBT-Type Applications**

GND = 0 V,  $t_R$ ,  $C_L = 50$  pF,  $G_{REF} = 5$  V  $\pm$  0.5 V,  $T_{amb} = -40^\circ\text{C}$  to  $85^\circ\text{C}$

PARAMETER		MIN	MAX	UNIT
$t_{pd}$	Propagation delay <sup>(1)</sup>		250	ps

(1) This parameter is warranted but not production tested. The propagation delay is based on the RC time constant of the typical on-state resistance of the switch and a load capacitance of 50 pF, when driven by an ideal voltage source (zero output impedance).

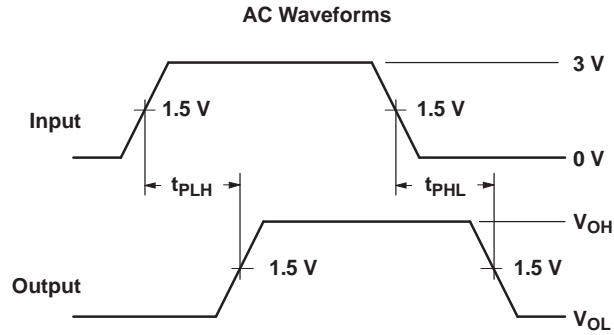

**Figure 3. Input (Sn) to Output (Dn) Propagation Delays**

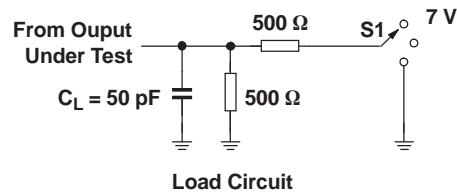

TEST	S1
$t_{pd}$	Open
$t_{PLZ}/t_{PZL}$	7 V
$t_{PHZ}/t_{PZH}$	Open

$C_L$  = Load capacitance, includes jig and probe capacitance (see AC Characteristics for value).

**Figure 4. Load Circuit**

## APPLICATION INFORMATION

### Bidirectional Translation

For the bidirectional clamping configuration (higher voltage to lower voltage or lower voltage to higher voltage), the  $G_{REF}$  input must be connected to  $D_{REF}$  and both pins pulled to HIGH-side  $V_{CC}$  through a pullup resistor (typically 200 k $\Omega$ ). A filter capacitor on  $D_{REF}$  is recommended. The processor output can be totem pole or open drain (pullup resistors) and the chipset output can be totem pole or open drain (pullup resistors are required to pull the Dn outputs to  $V_{CC}$ ). However, if either output is totem pole, data must be unidirectional or the outputs must be 3-statable, and the outputs must be controlled by some direction-control mechanism to prevent HIGH-to-LOW contentions in either direction. If both outputs are open drain, no direction control is needed. The opposite side of the reference transistor ( $S_{REF}$ ) is connected to the processor core power-supply voltage. When  $D_{REF}$  is connected through a 200-k $\Omega$  resistor to a 3.3-V to 5.5-V  $V_{CC}$  supply and  $S_{REF}$  is set between 1 V to  $V_{CC}$  1.5 V, the output of each Sn has a maximum output voltage equal to  $S_{REF}$ , and the output of each Dn has a maximum output voltage equal to  $V_{CC}$ .

APPLICATION INFORMATION (continued)

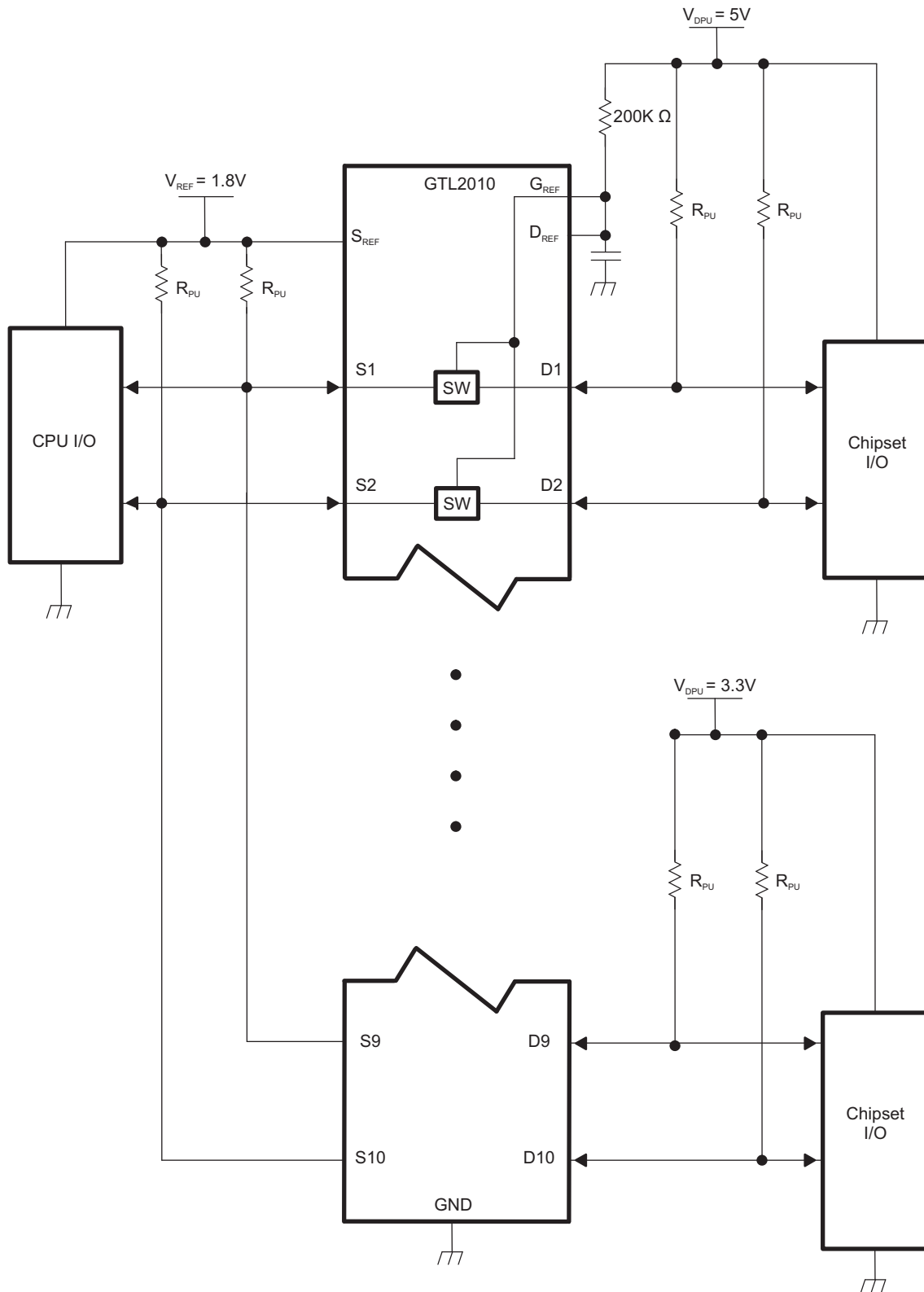
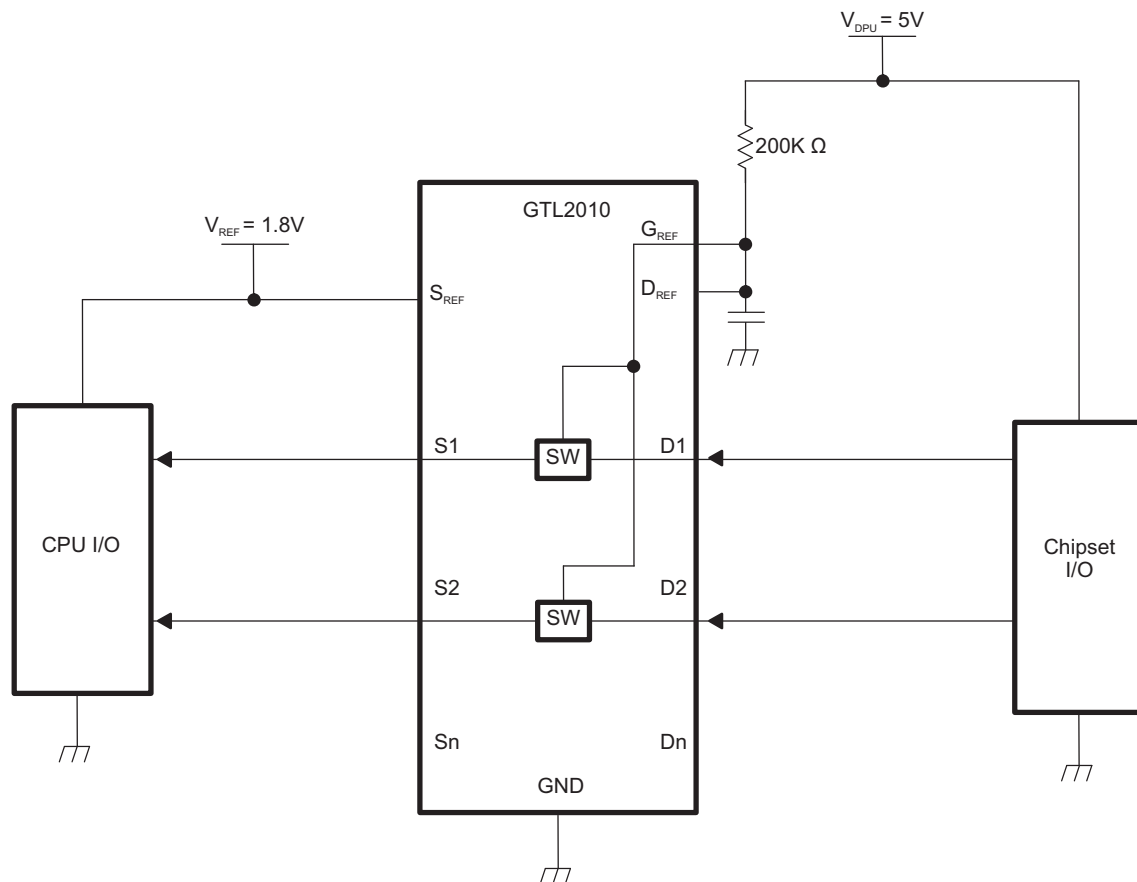

Figure 5. Bidirectional Translation to Multiple Higher Voltage Levels (Such as an I<sup>2</sup>C or SMBus Applications)

**APPLICATION INFORMATION (continued)**

**Unidirectional Down Translation**

For unidirectional clamping (higher voltage to lower voltage), the  $G_{REF}$  input must be connected to  $D_{REF}$  and both pins pulled to the higher-side  $V_{CC}$  through a pullup resistor (typically 200 k $\Omega$ ). A filter capacitor on  $D_{REF}$  is recommended. Pullup resistors are required if the chipset I/Os are open drain. The opposite side of the reference transistor ( $S_{REF}$ ) is connected to the processor core power-supply voltage. When  $D_{REF}$  is connected through a 200-k $\Omega$  resistor to a 3.3-V to 5.5-V  $V_{CC}$  supply and  $S_{REF}$  is set between 1 V to  $V_{CC} - 1.5$  V, the output of each  $S_n$  has a maximum output voltage equal to  $S_{REF}$ .



**Figure 6. Unidirectional Down Translation to Protect Low-Voltage Processor Pins**

APPLICATION INFORMATION (continued)

Unidirectional Up Translation

For unidirectional up translation (lower voltage to higher voltage), the reference transistor is connected the same as for a down translation. A pullup resistor is required on the higher voltage side (Dn or Sn) to get the full HIGH level, since the GTL device only passes the reference source ( $S_{REF}$ ) voltage as a HIGH when doing an up translation. The driver on the lower voltage side only needs pullup resistors if it is open drain.

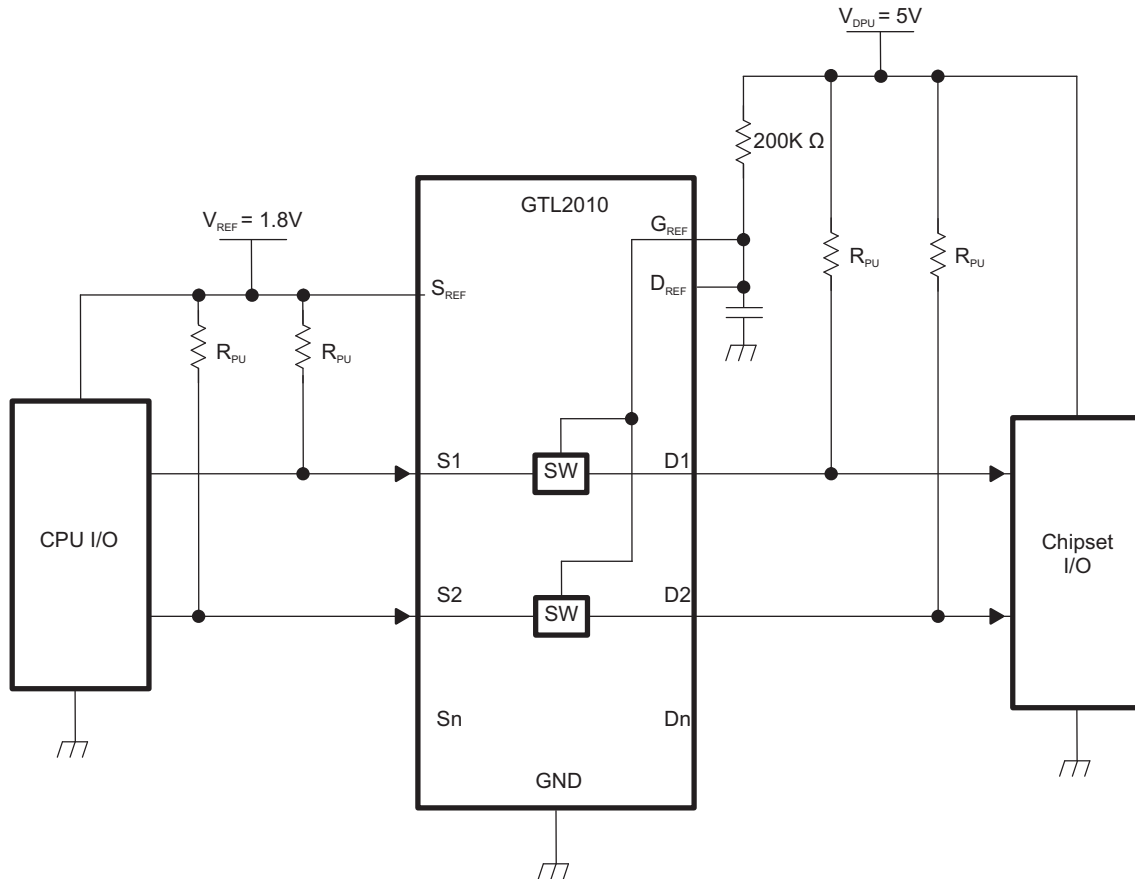

Figure 7. Unidirectional Up Translation to Higher-Voltage Chipsets

**APPLICATION INFORMATION (continued)**

**Sizing Pullup Resistor**

The pullup resistor value should limit the current through the pass transistor when it is in the on state to about 15 mA. This ensures a pass voltage of 260 mV to 350 mV. If the current through the pass transistor is higher than 15 mA, the pass voltage also is higher in the on state. To set the current through each pass transistor at 15 mA, the pullup resistor value is calculated as:

$$\text{Resistor value } (\Omega) = \frac{\text{Pullup voltage (V)} - 0.35 \text{ V}}{0.015 \text{ A}}$$

Table 1 shows resistor values for various reference voltages and currents at 15 mA, 10 mA, and 3 mA. The resistor value shown in the +10% column, or a larger value, should be used to ensure that the pass voltage of the transistor would be 350 mV or less. The external driver must be able to sink the total current from the resistors on both sides of the GTL device at 0.175 V, although the 15 mA only applies to current flowing through the GTL2010.

**Table 1. Pullup Resistor Values<sup>(1)(2)(3)</sup>**

PULLUP RESISTOR VALUE ( $\Omega$ )						
VOLTAGE	15 mA		10 mA		3 mA	
	NOMINAL	+10%	NOMINAL	+10%	NOMINAL	+10%
5.0 V	310	341	465	512	1550	1705
3.3 V	197	217	295	325	983	1082
2.5 V	143	158	215	237	717	788
1.8 V	97	106	145	160	483	532
1.5 V	77	85	115	127	383	422
1.2 V	57	63	85	94	283	312

- (1) Calculated for  $V_{OL} = 0.35 \text{ V}$
- (2) Assumes output driver  $V_{OL} = 0.175 \text{ V}$  at stated current
- (3) +10% to compensate for  $V_{DD}$  range and resistor tolerance

**PACKAGING INFORMATION**

Orderable Device	Status (1)	Package Type	Package Drawing	Pins	Package Qty	Eco Plan (2)	Lead/Ball Finish (6)	MSL Peak Temp (3)	Op Temp (°C)	Device Marking (4/5)	Samples
SN74GTL2010PW	ACTIVE	TSSOP	PW	24	60	Green (RoHS & no Sb/Br)	CU NIPDAU	Level-1-260C-UNLIM	-40 to 85	GK2010	<a href="#">Samples</a>
SN74GTL2010PWR	ACTIVE	TSSOP	PW	24	2000	Green (RoHS & no Sb/Br)	CU NIPDAU	Level-1-260C-UNLIM	-40 to 85	GK2010	<a href="#">Samples</a>

(1) The marketing status values are defined as follows:

**ACTIVE:** Product device recommended for new designs.

**LIFEBUY:** TI has announced that the device will be discontinued, and a lifetime-buy period is in effect.

**NRND:** Not recommended for new designs. Device is in production to support existing customers, but TI does not recommend using this part in a new design.

**PREVIEW:** Device has been announced but is not in production. Samples may or may not be available.

**OBSELETE:** TI has discontinued the production of the device.

(2) Eco Plan - The planned eco-friendly classification: Pb-Free (RoHS), Pb-Free (RoHS Exempt), or Green (RoHS & no Sb/Br) - please check <http://www.ti.com/productcontent> for the latest availability information and additional product content details.

**TBD:** The Pb-Free/Green conversion plan has not been defined.

**Pb-Free (RoHS):** TI's terms "Lead-Free" or "Pb-Free" mean semiconductor products that are compatible with the current RoHS requirements for all 6 substances, including the requirement that lead not exceed 0.1% by weight in homogeneous materials. Where designed to be soldered at high temperatures, TI Pb-Free products are suitable for use in specified lead-free processes.

**Pb-Free (RoHS Exempt):** This component has a RoHS exemption for either 1) lead-based flip-chip solder bumps used between the die and package, or 2) lead-based die adhesive used between the die and leadframe. The component is otherwise considered Pb-Free (RoHS compatible) as defined above.

**Green (RoHS & no Sb/Br):** TI defines "Green" to mean Pb-Free (RoHS compatible), and free of Bromine (Br) and Antimony (Sb) based flame retardants (Br or Sb do not exceed 0.1% by weight in homogeneous material)

(3) MSL, Peak Temp. - The Moisture Sensitivity Level rating according to the JEDEC industry standard classifications, and peak solder temperature.

(4) There may be additional marking, which relates to the logo, the lot trace code information, or the environmental category on the device.

(5) Multiple Device Markings will be inside parentheses. Only one Device Marking contained in parentheses and separated by a "~" will appear on a device. If a line is indented then it is a continuation of the previous line and the two combined represent the entire Device Marking for that device.

(6) Lead/Ball Finish - Orderable Devices may have multiple material finish options. Finish options are separated by a vertical ruled line. Lead/Ball Finish values may wrap to two lines if the finish value exceeds the maximum column width.

**Important Information and Disclaimer:** The information provided on this page represents TI's knowledge and belief as of the date that it is provided. TI bases its knowledge and belief on information provided by third parties, and makes no representation or warranty as to the accuracy of such information. Efforts are underway to better integrate information from third parties. TI has taken and continues to take reasonable steps to provide representative and accurate information but may not have conducted destructive testing or chemical analysis on incoming materials and chemicals. TI and TI suppliers consider certain information to be proprietary, and thus CAS numbers and other limited information may not be available for release.

In no event shall TI's liability arising out of such information exceed the total purchase price of the TI part(s) at issue in this document sold by TI to Customer on an annual basis.

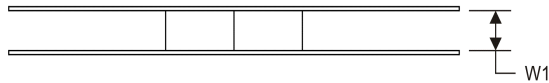
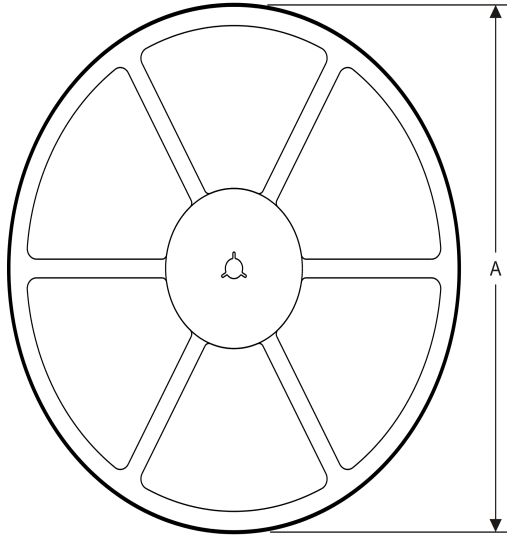
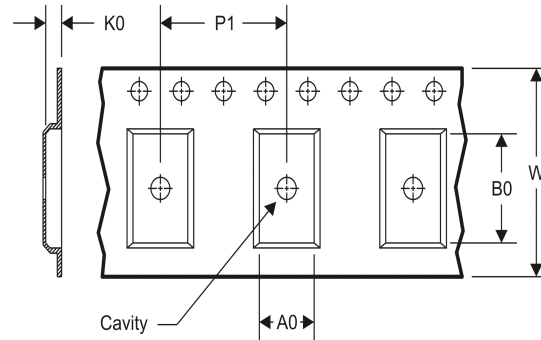
**TAPE AND REEL INFORMATION**
**REEL DIMENSIONS**

**TAPE DIMENSIONS**

A0	Dimension designed to accommodate the component width
B0	Dimension designed to accommodate the component length
K0	Dimension designed to accommodate the component thickness
W	Overall width of the carrier tape
P1	Pitch between successive cavity centers

**TAPE AND REEL INFORMATION**

\*All dimensions are nominal

Device	Package Type	Package Drawing	Pins	SPQ	Reel Diameter (mm)	Reel Width W1 (mm)	A0 (mm)	B0 (mm)	K0 (mm)	P1 (mm)	W (mm)	Pin1 Quadrant
SN74GTL2010PWR	TSSOP	PW	24	2000	330.0	16.4	6.95	8.3	1.6	8.0	16.0	Q1

TAPE AND REEL BOX DIMENSIONS



\*All dimensions are nominal



Device	Package Type	Package Drawing	Pins	SPQ	Length (mm)	Width (mm)	Height (mm)
SN74GTL2010PWR	TSSOP	PW	24	2000	367.0	367.0	38.0

PW (R-PDSO-G24)

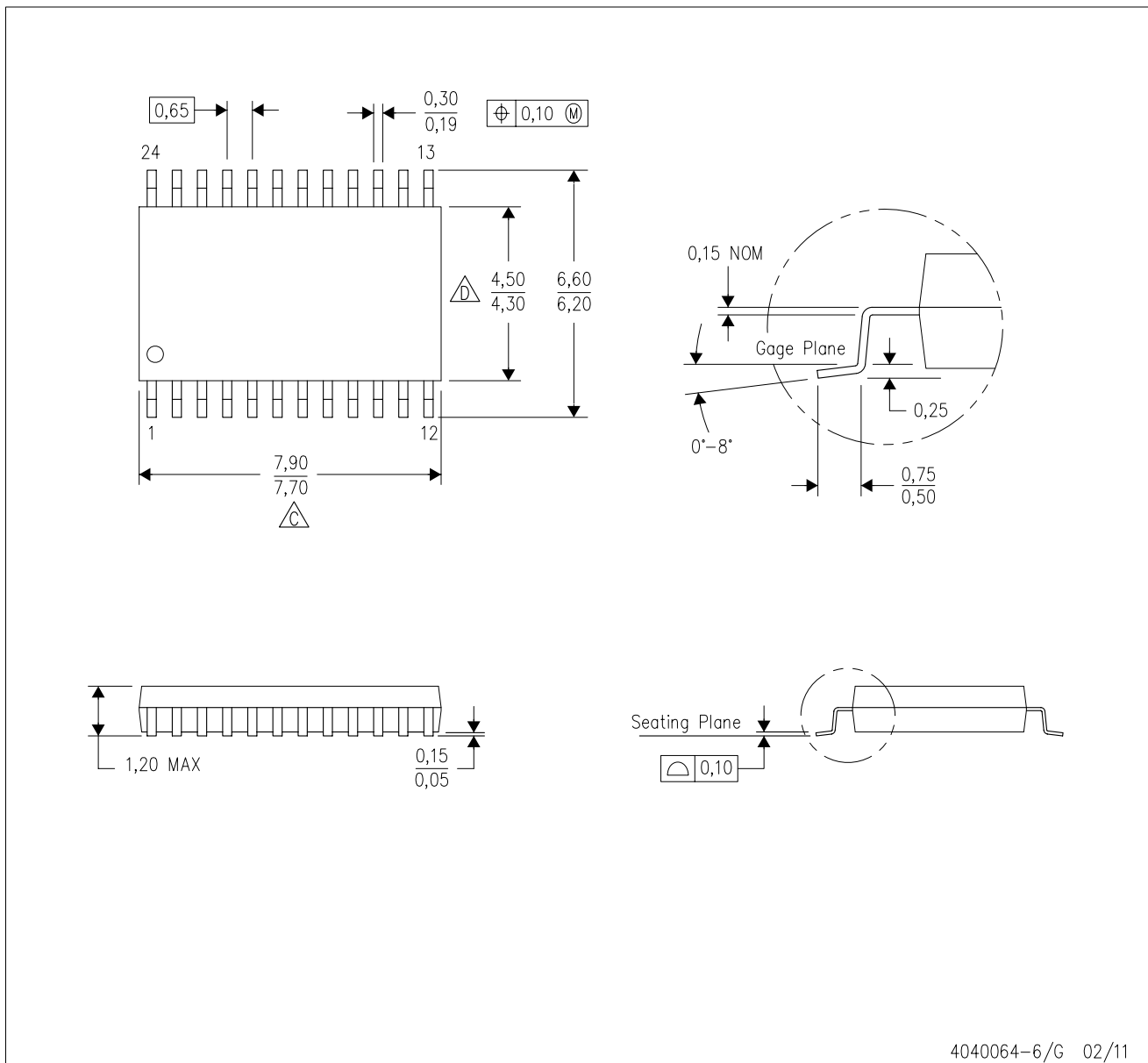
PLASTIC SMALL OUTLINE



4040064-6/G 02/11

- NOTES:
- A. All linear dimensions are in millimeters. Dimensioning and tolerancing per ASME Y14.5M-1994.
  - B. This drawing is subject to change without notice.
  -  Body length does not include mold flash, protrusions, or gate burrs. Mold flash, protrusions, or gate burrs shall not exceed 0,15 each side.
  -  Body width does not include interlead flash. Interlead flash shall not exceed 0,25 each side.
  - E. Falls within JEDEC MO-153

PW (R-PDSO-G24)

PLASTIC SMALL OUTLINE

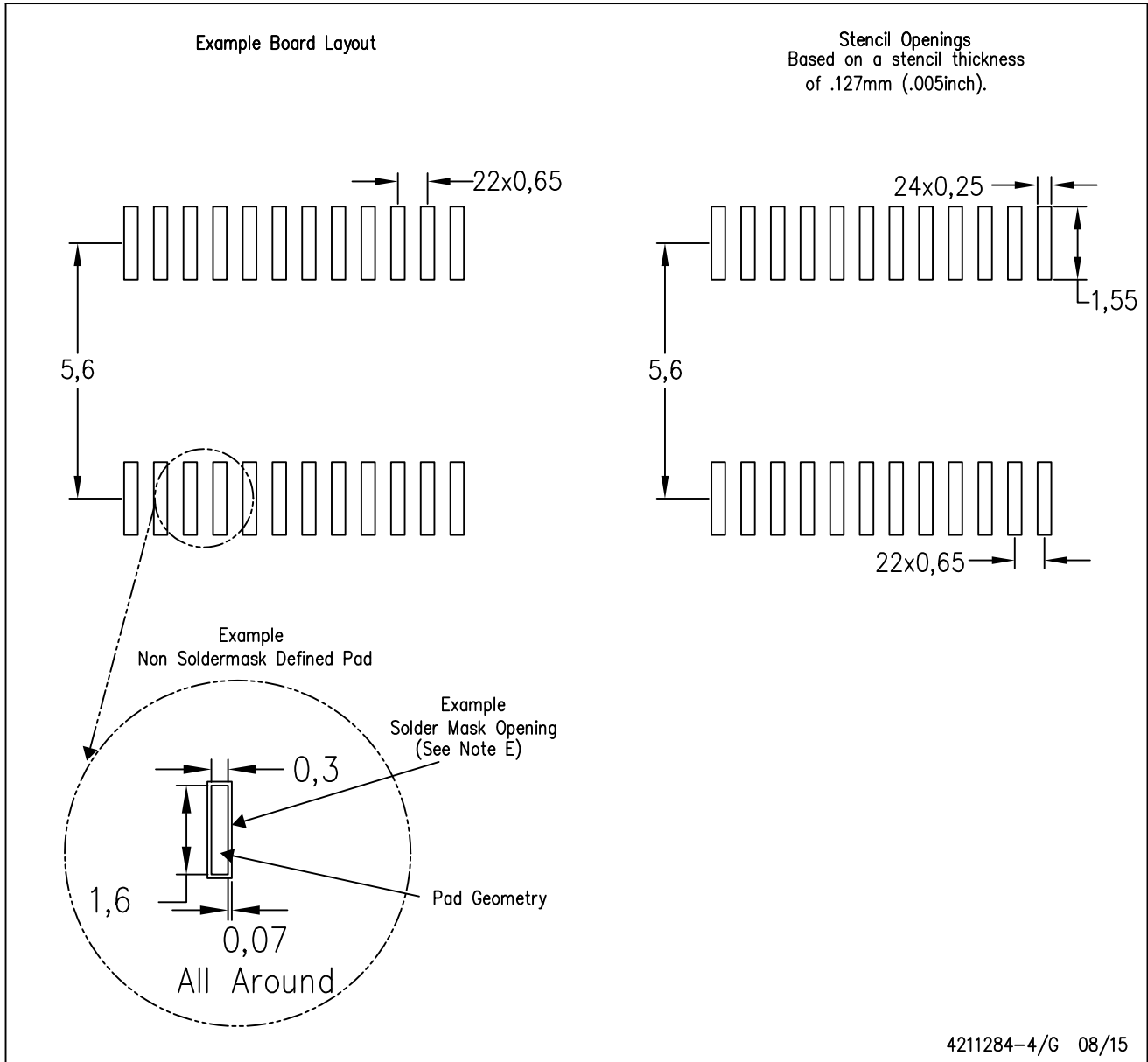

4211284-4/G 08/15

- NOTES:
- A. All linear dimensions are in millimeters.
  - B. This drawing is subject to change without notice.
  - C. Publication IPC-7351 is recommended for alternate design.
  - D. Laser cutting apertures with trapezoidal walls and also rounding corners will offer better paste release. Customers should contact their board assembly site for stencil design recommendations. Refer to IPC-7525 for other stencil recommendations.
  - E. Customers should contact their board fabrication site for solder mask tolerances between and around signal pads.

## IMPORTANT NOTICE

Texas Instruments Incorporated and its subsidiaries (TI) reserve the right to make corrections, enhancements, improvements and other changes to its semiconductor products and services per JESD46, latest issue, and to discontinue any product or service per JESD48, latest issue. Buyers should obtain the latest relevant information before placing orders and should verify that such information is current and complete. All semiconductor products (also referred to herein as "components") are sold subject to TI's terms and conditions of sale supplied at the time of order acknowledgment.

TI warrants performance of its components to the specifications applicable at the time of sale, in accordance with the warranty in TI's terms and conditions of sale of semiconductor products. Testing and other quality control techniques are used to the extent TI deems necessary to support this warranty. Except where mandated by applicable law, testing of all parameters of each component is not necessarily performed.

TI assumes no liability for applications assistance or the design of Buyers' products. Buyers are responsible for their products and applications using TI components. To minimize the risks associated with Buyers' products and applications, Buyers should provide adequate design and operating safeguards.

TI does not warrant or represent that any license, either express or implied, is granted under any patent right, copyright, mask work right, or other intellectual property right relating to any combination, machine, or process in which TI components or services are used. Information published by TI regarding third-party products or services does not constitute a license to use such products or services or a warranty or endorsement thereof. Use of such information may require a license from a third party under the patents or other intellectual property of the third party, or a license from TI under the patents or other intellectual property of TI.

Reproduction of significant portions of TI information in TI data books or data sheets is permissible only if reproduction is without alteration and is accompanied by all associated warranties, conditions, limitations, and notices. TI is not responsible or liable for such altered documentation. Information of third parties may be subject to additional restrictions.

Resale of TI components or services with statements different from or beyond the parameters stated by TI for that component or service voids all express and any implied warranties for the associated TI component or service and is an unfair and deceptive business practice. TI is not responsible or liable for any such statements.

Buyer acknowledges and agrees that it is solely responsible for compliance with all legal, regulatory and safety-related requirements concerning its products, and any use of TI components in its applications, notwithstanding any applications-related information or support that may be provided by TI. Buyer represents and agrees that it has all the necessary expertise to create and implement safeguards which anticipate dangerous consequences of failures, monitor failures and their consequences, lessen the likelihood of failures that might cause harm and take appropriate remedial actions. Buyer will fully indemnify TI and its representatives against any damages arising out of the use of any TI components in safety-critical applications.

In some cases, TI components may be promoted specifically to facilitate safety-related applications. With such components, TI's goal is to help enable customers to design and create their own end-product solutions that meet applicable functional safety standards and requirements. Nonetheless, such components are subject to these terms.

No TI components are authorized for use in FDA Class III (or similar life-critical medical equipment) unless authorized officers of the parties have executed a special agreement specifically governing such use.

Only those TI components which TI has specifically designated as military grade or "enhanced plastic" are designed and intended for use in military/aerospace applications or environments. Buyer acknowledges and agrees that any military or aerospace use of TI components which have **not** been so designated is solely at the Buyer's risk, and that Buyer is solely responsible for compliance with all legal and regulatory requirements in connection with such use.

TI has specifically designated certain components as meeting ISO/TS16949 requirements, mainly for automotive use. In any case of use of non-designated products, TI will not be responsible for any failure to meet ISO/TS16949.

### Products

Audio	<a href="http://www.ti.com/audio">www.ti.com/audio</a>
Amplifiers	<a href="http://amplifier.ti.com">amplifier.ti.com</a>
Data Converters	<a href="http://dataconverter.ti.com">dataconverter.ti.com</a>
DLP® Products	<a href="http://www.dlp.com">www.dlp.com</a>
DSP	<a href="http://dsp.ti.com">dsp.ti.com</a>
Clocks and Timers	<a href="http://www.ti.com/clocks">www.ti.com/clocks</a>
Interface	<a href="http://interface.ti.com">interface.ti.com</a>
Logic	<a href="http://logic.ti.com">logic.ti.com</a>
Power Mgmt	<a href="http://power.ti.com">power.ti.com</a>
Microcontrollers	<a href="http://microcontroller.ti.com">microcontroller.ti.com</a>
RFID	<a href="http://www.ti-rfid.com">www.ti-rfid.com</a>
OMAP Applications Processors	<a href="http://www.ti.com/omap">www.ti.com/omap</a>
Wireless Connectivity	<a href="http://www.ti.com/wirelessconnectivity">www.ti.com/wirelessconnectivity</a>

### Applications

Automotive and Transportation	<a href="http://www.ti.com/automotive">www.ti.com/automotive</a>
Communications and Telecom	<a href="http://www.ti.com/communications">www.ti.com/communications</a>
Computers and Peripherals	<a href="http://www.ti.com/computers">www.ti.com/computers</a>
Consumer Electronics	<a href="http://www.ti.com/consumer-apps">www.ti.com/consumer-apps</a>
Energy and Lighting	<a href="http://www.ti.com/energy">www.ti.com/energy</a>
Industrial	<a href="http://www.ti.com/industrial">www.ti.com/industrial</a>
Medical	<a href="http://www.ti.com/medical">www.ti.com/medical</a>
Security	<a href="http://www.ti.com/security">www.ti.com/security</a>
Space, Avionics and Defense	<a href="http://www.ti.com/space-avionics-defense">www.ti.com/space-avionics-defense</a>
Video and Imaging	<a href="http://www.ti.com/video">www.ti.com/video</a>

### TI E2E Community

[e2e.ti.com](http://e2e.ti.com)