

FEATURES

- Member of the Texas Instruments Widebus™ Family
- TI-OPC™ Circuitry Limits Ringing on Unevenly Loaded Backplanes
- OEC™ Circuitry Improves Signal Integrity and Reduces Electromagnetic Interference
- Bidirectional Interface Between GTLP Signal Levels and LVTTTL Logic Levels
- LVTTTL Interfaces Are 5-V Tolerant
- Medium-Drive GTLP Outputs (50 mA)
- LVTTTL Outputs (–24 mA/24 mA)
- GTLP Rise and Fall Times Designed for Optimal Data-Transfer Rate and Signal Integrity in Distributed Loads
- I_{off} , Power-Up 3-State, and BIAS V_{CC} Support Live Insertion
- Bus Hold on A-Port Data Inputs
- Distributed V_{CC} and GND Pins Minimize High-Speed Switching Noise
- Latch-Up Performance Exceeds 100 mA Per JESD 78, Class II

DGG OR DGV PACKAGE
(TOP VIEW)

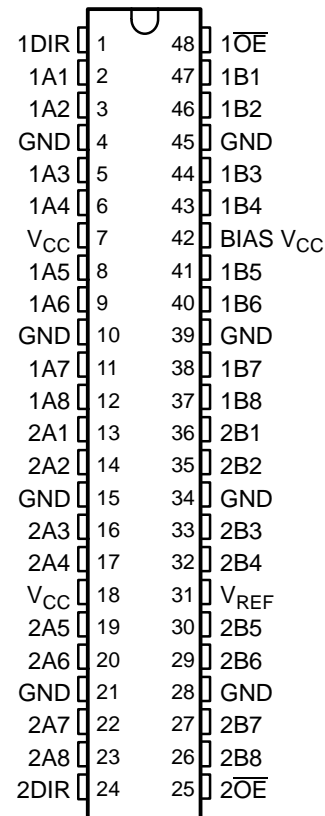

DESCRIPTION/ORDERING INFORMATION

The SN74GTLPH16945 is a medium-drive, 16-bit bus transceiver that provides LVTTTL-to-GTLP and GTLP-to-LVTTTL signal-level translation. It is partitioned as two 8-bit transceivers. The device provides a high-speed interface between cards operating at LVTTTL logic levels and a backplane operating at GTLP signal levels. High-speed (about three times faster than standard TTL or LVTTTL) backplane operation is a direct result of GTLP's reduced output swing (<1 V), reduced input threshold levels, improved differential input, OEC™ circuitry, and TI-OPC™ circuitry. Improved GTLP OEC and TI-OPC circuits minimize bus-settling time and have been designed and tested using several backplane models. The medium drive allows incident-wave switching in heavily loaded backplanes with equivalent load impedance down to 19 Ω .

GTLP is the Texas Instruments (TI™) derivative of the Gunning Transceiver Logic (GTL) JEDEC standard JESD 8-3. The ac specification of the SN74GTLPH16945 is given only at the preferred higher noise margin GTLP, but the user has the flexibility of using this device at either GTL ($V_{TT} = 1.2$ V and $V_{REF} = 0.8$ V) or GTLP ($V_{TT} = 1.5$ V and $V_{REF} = 1$ V) signal levels.

Normally, the B port operates at GTLP signal levels. The A-port and control inputs operate at LVTTTL logic levels, but are 5-V tolerant and are compatible with TTL and 5-V CMOS inputs. V_{REF} is the B-port differential input reference voltage.



Please be aware that an important notice concerning availability, standard warranty, and use in critical applications of Texas Instruments semiconductor products and disclaimers thereto appears at the end of this data sheet.

Widebus, TI-OPC, OEC, TI are trademarks of Texas Instruments.

SN74GTLPH16945

16-BIT LVTTTL-TO-GTLP BUS TRANSCEIVER

SCES292D–OCTOBER 1999–REVISED JUNE 2005

DESCRIPTION/ORDERING INFORMATION (CONTINUED)

This device is fully specified for live-insertion applications using I_{off} , power-up 3-state, and BIAS V_{CC} . The I_{off} circuitry disables the outputs, preventing damaging current backflow through the device when it is powered down. The power-up 3-state circuitry places the outputs in the high-impedance state during power up and power down, which prevents driver conflict. The BIAS V_{CC} circuitry precharges and preconditions the B-port input/output connections, preventing disturbance of active data on the backplane during card insertion or removal, and permits true live-insertion capability.

This GTLP device features TI-OPC circuitry, which actively limits overshoot caused by improperly terminated backplanes, unevenly distributed cards, or empty slots during low-to-high signal transitions. This improves signal integrity, which allows adequate noise margin to be maintained at higher frequencies.

Active bus-hold circuitry holds unused or undriven LVTTTL data inputs at a valid logic state. Use of pullup or pulldown resistors with the bus-hold circuitry is not recommended.

When V_{CC} is between 0 and 1.5 V, the device is in the high-impedance state during power up or power down. However, to ensure the high-impedance state above 1.5 V, the output-enable (\overline{OE}) input should be tied to V_{CC} through a pullup resistor; the minimum value of the resistor is determined by the current-sinking capability of the driver.

ORDERING INFORMATION

T_A	PACKAGE (1)		ORDERABLE PART NUMBER	TOP-SIDE MARKING
–40°C to 85°C	TSSOP – DGG	Tape and reel	SN74GTLPH16945GR	GTLPH16945
	TVSOP – DGV	Tape and reel	SN74GTLPH16945VR	GL945
	VFBGA – GQL	Tape and reel	SN74GTLPH16945KR	GL945

(1) Package drawings, standard packing quantities, thermal data, symbolization, and PCB design guidelines are available at www.ti.com/sc/package.

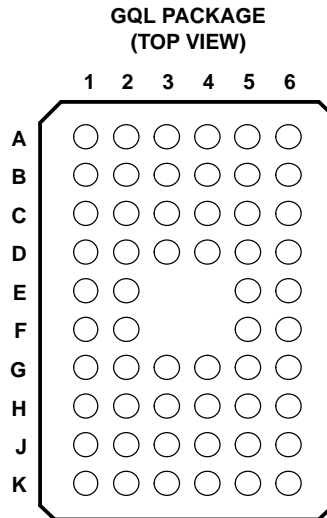

TERMINAL ASSIGNMENTS⁽¹⁾

	1	2	3	4	5	6
A	1DIR	NC	NC	NC	NC	1 \overline{OE}
B	1A2	1A1	GND	GND	1B1	1B2
C	1A4	1A3	V _{CC}	BIAS V _{CC}	1B3	1B4
D	1A6	1A5	GND	GND	1B5	1B6
E	2A8	1A7			1B7	1B8
F	2A1	2A2			2B2	2B1
G	2A3	2A4	GND	GND	2B4	2B3
H	2A5	2A6	V _{CC}	V _{REF}	2B6	2B5
J	2A7	2A8	GND	GND	2B8	2B7
K	2DIR	NC	NC	NC	NC	2 \overline{OE}

(1) NC – No internal connection

FUNCTIONAL DESCRIPTION

The SN74GTLPH16945 is a medium-drive (50 mA), 16-bit bus transceiver partitioned as two 8-bit segments and is designed for asynchronous communication between data buses. The device transmits data from the A port to the B port or from the B port to the A port, depending on the logic level at the direction-control (DIR) input. \overline{OE} can be used to disable the device so the buses effectively are isolated. Data polarity is noninverting.

For A-to-B data flow, when \overline{OE} is low and DIR is high, the B outputs take on the logic value of the A inputs. When \overline{OE} is high, the outputs are in the high-impedance state.

The data flow for B to A is similar to that of A to B, except \overline{OE} and DIR are low.

FUNCTION TABLE

INPUTS		OUTPUT	MODE
\overline{OE}	DIR		
H	X	Z	Isolation
L	L	B data to A port	True transparent
L	H	A data to B port	

SN74GTLPH16945
16-BIT LVTTTL-TO-GTLP BUS TRANSCEIVER

SCES292D—OCTOBER 1999—REVISED JUNE 2005

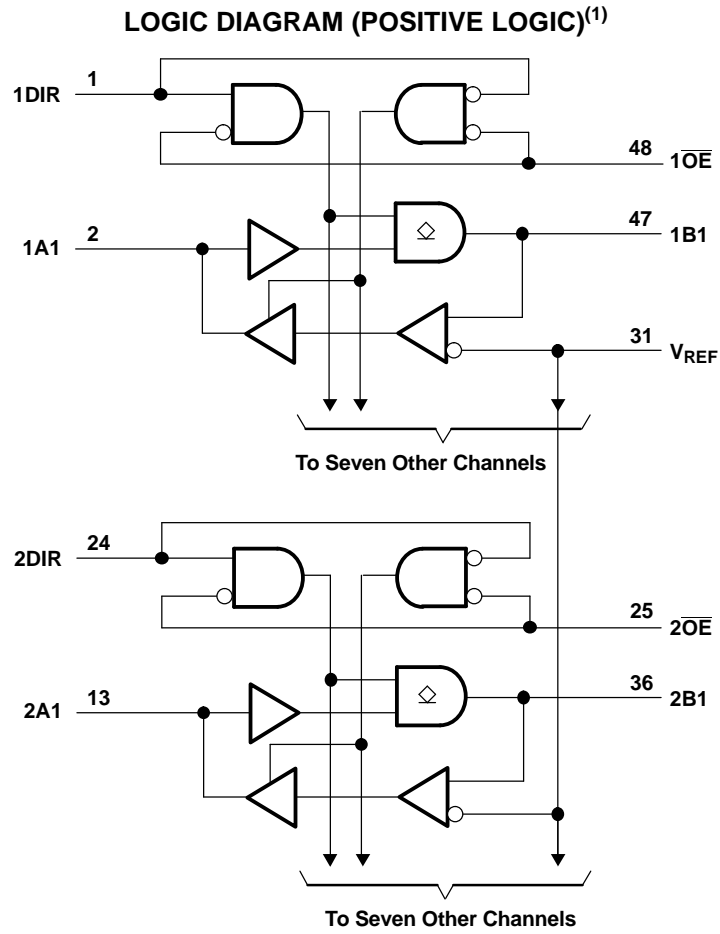

(1) Pin numbers shown are for the DGG and DGV packages.

Absolute Maximum Ratings⁽¹⁾

over operating free-air temperature range (unless otherwise noted)

		MIN	MAX	UNIT	
V_{CC} BIAS V_{CC}	Supply voltage range	-0.5	4.6	V	
V_I	Input voltage range ⁽²⁾	A-port and control inputs	-0.5	7	V
		B port and V_{REF}	-0.5	4.6	
V_O	Voltage range applied to any output in the high-impedance or power-off state	A port	-0.5	7	V
		B port	-0.5	4.6	
I_O	Current into any output in the low state	A port		48	mA
		B port		100	
I_O	Current into any A-port output in the high state ⁽³⁾		48	mA	
	Continuous current through each V_{CC} or GND		±100	mA	
I_{IK}	Input clamp current	$V_I < 0$		-50	mA
I_{OK}	Output clamp current	$V_O < 0$		-50	mA
θ_{JA}	Package thermal impedance ⁽⁴⁾	DGG package		70	°C/W
		DGV package		58	
		GQL package		42	
T_{stg}	Storage temperature range	-65	150	°C	

- (1) Stresses beyond those listed under "absolute maximum ratings" may cause permanent damage to the device. These are stress ratings only, and functional operation of the device at these or any other conditions beyond those indicated under "recommended operating conditions" is not implied. Exposure to absolute-maximum-rated conditions for extended periods may affect device reliability.
- (2) The input and output negative-voltage ratings may be exceeded if the input and output clamp-current ratings are observed.
- (3) This current flows only when the output is in the high state and $V_O > V_{CC}$.
- (4) The package thermal impedance is calculated in accordance with JESD 51-7.

SN74GTLPH16945

16-BIT LVTTTL-TO-GTLP BUS TRANSCEIVER

SCES292D–OCTOBER 1999–REVISED JUNE 2005

Recommended Operating Conditions⁽¹⁾⁽²⁾⁽³⁾⁽⁴⁾

		MIN	NOM	MAX	UNIT	
V_{CC} BIAS V_{CC}	Supply voltage	3.15	3.3	3.45	V	
V_{TT}	Termination voltage	GTL	1.14	1.2	1.26	V
		GTLP	1.35	1.5	1.65	
V_{REF}	Reference voltage	GTL	0.74	0.8	0.87	V
		GTLP	0.87	1	1.1	
V_I	Input voltage	B port		V_{TT}	V	
		Except B port		V_{CC}		
V_{IH}	High-level input voltage	B port	$V_{REF} + 0.05$		V	
		Except B port	2			
V_{IL}	Low-level input voltage	B port		$V_{REF} - 0.05$	V	
		Except B port		0.8		
I_{IK}	Input clamp current			-18	mA	
I_{OH}	High-level output current	A port		-24	mA	
I_{OL}	Low-level output current	A port		24	mA	
		B port		50		
?t/?V	Input transition rise or fall rate	Outputs enabled		10	ns/V	
?t/? V_{CC}	Power-up ramp rate	20			μ s/V	
T_A	Operating free-air temperature	-40		85	$^{\circ}$ C	

- (1) All unused inputs of the device must be held at V_{CC} or GND to ensure proper device operation. Refer to the TI application report, *Implications of Slow or Floating CMOS Inputs*, literature number SCBA004.
- (2) Proper connection sequence for use of the B-port I/O precharge feature is GND and BIAS $V_{CC} = 3.3$ V first, I/O second, and $V_{CC} = 3.3$ V last, because the BIAS V_{CC} precharge circuitry is disabled when any V_{CC} pin is connected. The control and V_{REF} inputs can be connected anytime, but normally are connected during the I/O stage. If B-port precharge is not required, any connection sequence is acceptable but, generally, GND is connected first.
- (3) V_{TT} and R_{TT} can be adjusted to accommodate backplane impedances if the dc recommended I_{OL} ratings are not exceeded.
- (4) V_{REF} can be adjusted to optimize noise margins, but normally is two-thirds V_{TT} . TI-OPC circuitry is enabled in the A-to-B direction and is activated when $V_{TT} > 0.7$ V above V_{REF} . If operated in the A-to-B direction, V_{REF} should be set to within 0.6 V of V_{TT} to minimize current drain.

Electrical Characteristics

over recommended operating free-air temperature range for GTLP (unless otherwise noted)

PARAMETER		TEST CONDITIONS			MIN	TYP ⁽¹⁾	MAX	UNIT	
V_{IK}		$V_{CC} = 3.15\text{ V}$,	$I_I = -18\text{ mA}$				-1.2	V	
V_{OH}	A port	$V_{CC} = 3.15\text{ V to }3.45\text{ V}$,	$I_{OH} = -100\text{ }\mu\text{A}$	$V_{CC} - 0.2$				V	
		$V_{CC} = 3.15\text{ V}$	$I_{OH} = -12\text{ mA}$	2.4					
			$I_{OH} = -24\text{ mA}$	2					
V_{OL}	A port	$V_{CC} = 3.15\text{ V to }3.45\text{ V}$,	$I_{OL} = 100\text{ }\mu\text{A}$				0.2	V	
		$V_{CC} = 3.15\text{ V}$	$I_{OL} = 12\text{ mA}$				0.4		
			$I_{OL} = 24\text{ mA}$				0.5		
	B port	$V_{CC} = 3.15\text{ V to }3.45\text{ V}$,	$I_{OL} = 100\text{ }\mu\text{A}$				0.2		
		$V_{CC} = 3.15\text{ V}$	$I_{OL} = 10\text{ mA}$				0.2		
			$I_{OL} = 40\text{ mA}$				0.4		
		$I_{OL} = 50\text{ mA}$				0.55			
I_I	Control inputs	$V_{CC} = 3.45\text{ V}$,	$V_I = 0\text{ or }5.5\text{ V}$				± 10	μA	
$I_{OZH}^{(2)}$	A port	$V_{CC} = 3.45\text{ V}$	$V_O = V_{CC}$				10	μA	
	B port		$V_O = 1.5\text{ V}$				10		
$I_{OZL}^{(2)}$	A and B ports	$V_{CC} = 3.45\text{ V}$,	$V_O = \text{GND}$				-10	μA	
$I_{BHL}^{(3)}$	A port	$V_{CC} = 3.15\text{ V}$,	$V_I = 0.8\text{ V}$				75	μA	
$I_{BHH}^{(4)}$	A port	$V_{CC} = 3.15\text{ V}$,	$V_I = 2\text{ V}$				-75	μA	
$I_{BHLO}^{(5)}$	A port	$V_{CC} = 3.45\text{ V}$,	$V_I = 0\text{ to }V_{CC}$				500	μA	
$I_{BHHO}^{(6)}$	A port	$V_{CC} = 3.45\text{ V}$,	$V_I = 0\text{ to }V_{CC}$				-500	μA	
I_{CC}	A or B port	$V_{CC} = 3.45\text{ V}$, $I_O = 0$, V_I (A-port or control input) = V_{CC} or GND, V_I (B port) = V_{TT} or GND	Outputs high				50	mA	
			Outputs low				50		
			Outputs disabled				50		
$?I_{CC}^{(7)}$		$V_{CC} = 3.45\text{ V}$, One A-port or control input at $V_{CC} - 0.6\text{ V}$, Other A-port or control inputs at V_{CC} or GND					1.5	mA	
C_i	Control inputs	$V_I = 3.15\text{ V or }0$					4.5	5	pF
C_{io}	A port	$V_O = 3.15\text{ V or }0$					7.5	9	pF
	B port	$V_O = 1.5\text{ V or }0$					7.5	9	

(1) All typical values are at $V_{CC} = 3.3\text{ V}$, $T_A = 25^\circ\text{C}$.

(2) For I/O ports, the parameters I_{OZH} and I_{OZL} include the input leakage current.

(3) The bus-hold circuit can sink at least the minimum low sustaining current at V_{ILmax} . I_{BHL} should be measured after lowering V_{IN} to GND and then raising it to V_{ILmax} .

(4) The bus-hold circuit can source at least the minimum high sustaining current at V_{IHmin} . I_{BHH} should be measured after raising V_{IN} to V_{CC} and then lowering it to V_{IHmin} .

(5) An external driver must source at least I_{BHLO} to switch this node from low to high.

(6) An external driver must sink at least I_{BHHO} to switch this node from high to low.

(7) This is the increase in supply current for each input that is at the specified TTL voltage level, rather than V_{CC} or GND.

Hot-Insertion Specifications for A Port

over recommended operating free-air temperature range

PARAMETER	TEST CONDITIONS			MIN	MAX	UNIT
I_{off}	$V_{CC} = 0$,	BIAS $V_{CC} = 0$,	V_I or $V_O = 0\text{ to }5.5\text{ V}$		10	μA
I_{OZPU}	$V_{CC} = 0\text{ to }1.5\text{ V}$,	$V_O = 0.5\text{ V to }3\text{ V}$,	$\overline{OE} = 0$		± 30	μA
I_{OZPD}	$V_{CC} = 1.5\text{ V to }0$,	$V_O = 0.5\text{ V to }3\text{ V}$,	$\overline{OE} = 0$		± 30	μA

SN74GTLPH16945

16-BIT LVTTL-TO-GTLP BUS TRANSCEIVER

SCES292D—OCTOBER 1999—REVISED JUNE 2005

Live-Insertion Specifications for B Port

over recommended operating free-air temperature range

PARAMETER	TEST CONDITIONS			MIN	MAX	UNIT
I_{off}	$V_{CC} = 0,$	BIAS $V_{CC} = 0,$	V_I or $V_O = 0$ to 1.5 V	10		μA
I_{OZPU}	$V_{CC} = 0$ to 1.5 V,	BIAS $V_{CC} = 0,$	$V_O = 0.5$ V to 1.5 V, $\overline{OE} = 0$	± 30		μA
I_{OZPD}	$V_{CC} = 1.5$ V to 0,	BIAS $V_{CC} = 0,$	$V_O = 0.5$ V to 1.5 V, $\overline{OE} = 0$	± 30		μA
I_{CC} (BIAS V_{CC})	$V_{CC} = 0$ to 3.15 V	BIAS $V_{CC} = 3.15$ V to 3.45 V,	V_O (B port) = 0 to 1.5 V	5		mA
	$V_{CC} = 3.15$ V to 3.45 V			10		μA
V_O	$V_{CC} = 0,$	BIAS $V_{CC} = 3.3$ V,	$I_O = 0$	0.95	1.05	V
I_O	$V_{CC} = 0,$	BIAS $V_{CC} = 3.15$ V to 3.45 V,	V_O (B port) = 0.6 V	-1		μA

Switching Characteristics

over recommended ranges of supply voltage and operating free-air temperature,
 $V_{TT} = 1.5$ V and $V_{REF} = 1$ V for GTLP (see Figure 1)

PARAMETER	FROM (INPUT)	TO (OUTPUT)	MIN	TYP ⁽¹⁾	MAX	UNIT
t_{PLH}	A	B	2.1		6.3	ns
t_{PHL}			2.1		6.3	
t_{en}	\overline{OE}	B	2		6.9	ns
t_{dis}			2		6.9	
t_r	Rise time, B outputs (20% to 80%)		2.5			ns
t_f	Fall time, B outputs (80% to 20%)		2.1			ns
t_{PLH}	B	A	2.1		5.3	ns
t_{PHL}			2.1		5.3	
t_{en}	\overline{OE}	A	0.3		5.7	ns
t_{dis}			0.3		5.7	

(1) All typical values are at $V_{CC} = 3.3$ V, $T_A = 25^\circ C$.

PARAMETER MEASUREMENT INFORMATION

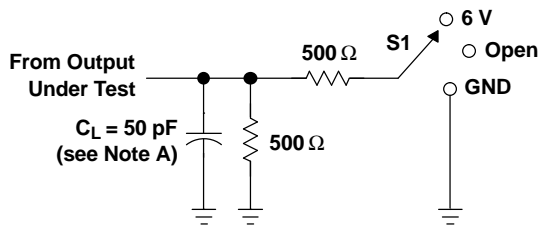

LOAD CIRCUIT FOR A OUTPUTS

TEST	S1
t_{PLH}/t_{PHL}	Open
t_{PLZ}/t_{PZL}	6 V
t_{PHZ}/t_{PZH}	GND

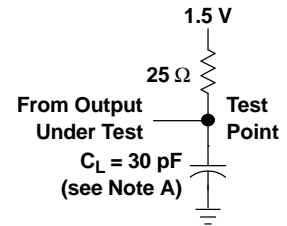

LOAD CIRCUIT FOR B OUTPUTS

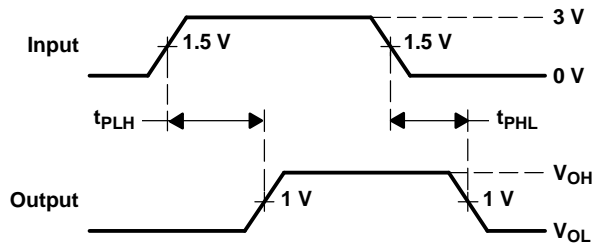

VOLTAGE WAVEFORMS
PROPAGATION DELAY TIMES
(A port to B port)

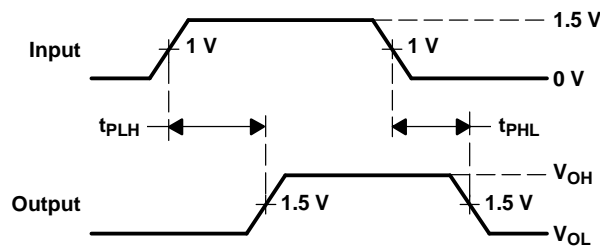

VOLTAGE WAVEFORMS
PROPAGATION DELAY TIMES
(B port to A port)

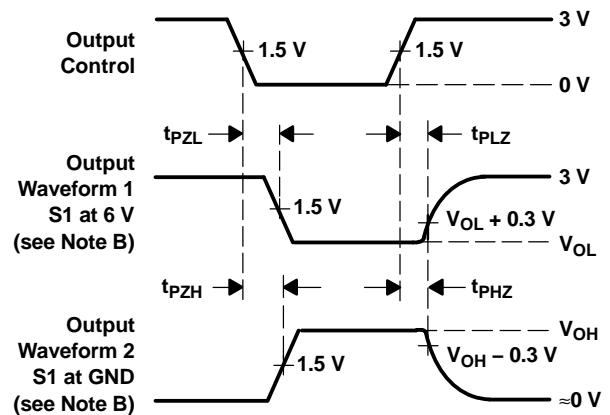

VOLTAGE WAVEFORMS
ENABLE AND DISABLE TIMES
(A port)

- NOTES: A. C_L includes probe and jig capacitance.
 B. Waveform 1 is for an output with internal conditions such that the output is low, except when disabled by the output control. Waveform 2 is for an output with internal conditions such that the output is high, except when disabled by the output control.
 C. All input pulses are supplied by generators having the following characteristics: PRR \approx 10 MHz, $Z_O = 50 \Omega$, $t_r \approx 2$ ns, $t_f \approx 2$ ns.
 D. The outputs are measured one at a time, with one transition per measurement.

Figure 1. Load Circuits and Voltage Waveforms

Distributed-Load Backplane Switching Characteristics

The preceding switching characteristics table shows the switching characteristics of the device into a lumped load (Figure 1). However, the designer's backplane application probably is a distributed load. The physical representation is shown in Figure 2. This backplane, or distributed load, can be approximated closely to a resistor inductance capacitance (RLC) circuit, as shown in Figure 3. This device has been designed for optimum performance in this RLC circuit. The following switching characteristics table shows the switching characteristics of the device into the RLC load, to help the designer better understand the performance of the GTLP device in this typical backplane. See www.ti.com/sc/gtlp for more information.

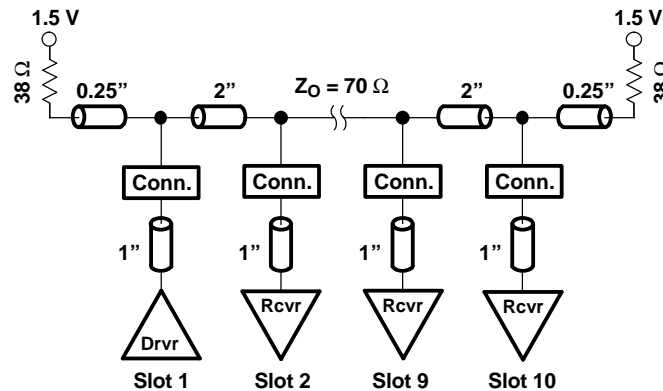

Figure 2. Medium-Drive Test Backplane

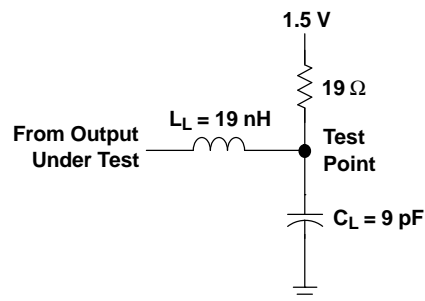

Figure 3. Medium-Drive RLC Network

Switching Characteristics

over recommended ranges of supply voltage and operating free-air temperature,
 $V_{TT} = 1.5\text{ V}$ and $V_{REF} = 1\text{ V}$ for GTLP (see Figure 3)

PARAMETER	FROM (INPUT)	TO (OUTPUT)	TYP (1)	UNIT
t_{PLH}	A	B	4.3	ns
t_{PHL}			4.3	
t_{en}	\overline{OE}	B	5	ns
t_{dis}			4.4	
t_r	Rise time, B outputs (20% to 80%)		1	ns
t_f	Fall time, B outputs (80% to 20%)		2	ns

(1) All typical values are at $V_{CC} = 3.3\text{ V}$, $T_A = 25^\circ\text{C}$. All values are derived from TI-SPICE models.

PACKAGING INFORMATION

Orderable Device	Status (1)	Package Type	Package Drawing	Pins	Package Qty	Eco Plan (2)	Lead/Ball Finish (6)	MSL Peak Temp (3)	Op Temp (°C)	Device Marking (4/5)	Samples
SN74GTLPH16945GR	ACTIVE	TSSOP	DGG	48	2000	Green (RoHS & no Sb/Br)	CU NIPDAU	Level-1-260C-UNLIM	-40 to 85	GTLPH16945	Samples

(1) The marketing status values are defined as follows:

ACTIVE: Product device recommended for new designs.

LIFEBUY: TI has announced that the device will be discontinued, and a lifetime-buy period is in effect.

NRND: Not recommended for new designs. Device is in production to support existing customers, but TI does not recommend using this part in a new design.

PREVIEW: Device has been announced but is not in production. Samples may or may not be available.

OBSOLETE: TI has discontinued the production of the device.

(2) Eco Plan - The planned eco-friendly classification: Pb-Free (RoHS), Pb-Free (RoHS Exempt), or Green (RoHS & no Sb/Br) - please check <http://www.ti.com/productcontent> for the latest availability information and additional product content details.

TBD: The Pb-Free/Green conversion plan has not been defined.

Pb-Free (RoHS): TI's terms "Lead-Free" or "Pb-Free" mean semiconductor products that are compatible with the current RoHS requirements for all 6 substances, including the requirement that lead not exceed 0.1% by weight in homogeneous materials. Where designed to be soldered at high temperatures, TI Pb-Free products are suitable for use in specified lead-free processes.

Pb-Free (RoHS Exempt): This component has a RoHS exemption for either 1) lead-based flip-chip solder bumps used between the die and package, or 2) lead-based die adhesive used between the die and leadframe. The component is otherwise considered Pb-Free (RoHS compatible) as defined above.

Green (RoHS & no Sb/Br): TI defines "Green" to mean Pb-Free (RoHS compatible), and free of Bromine (Br) and Antimony (Sb) based flame retardants (Br or Sb do not exceed 0.1% by weight in homogeneous material)

(3) MSL, Peak Temp. - The Moisture Sensitivity Level rating according to the JEDEC industry standard classifications, and peak solder temperature.

(4) There may be additional marking, which relates to the logo, the lot trace code information, or the environmental category on the device.

(5) Multiple Device Markings will be inside parentheses. Only one Device Marking contained in parentheses and separated by a "~" will appear on a device. If a line is indented then it is a continuation of the previous line and the two combined represent the entire Device Marking for that device.

(6) Lead/Ball Finish - Orderable Devices may have multiple material finish options. Finish options are separated by a vertical ruled line. Lead/Ball Finish values may wrap to two lines if the finish value exceeds the maximum column width.

Important Information and Disclaimer: The information provided on this page represents TI's knowledge and belief as of the date that it is provided. TI bases its knowledge and belief on information provided by third parties, and makes no representation or warranty as to the accuracy of such information. Efforts are underway to better integrate information from third parties. TI has taken and continues to take reasonable steps to provide representative and accurate information but may not have conducted destructive testing or chemical analysis on incoming materials and chemicals. TI and TI suppliers consider certain information to be proprietary, and thus CAS numbers and other limited information may not be available for release.

In no event shall TI's liability arising out of such information exceed the total purchase price of the TI part(s) at issue in this document sold by TI to Customer on an annual basis.

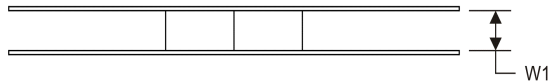
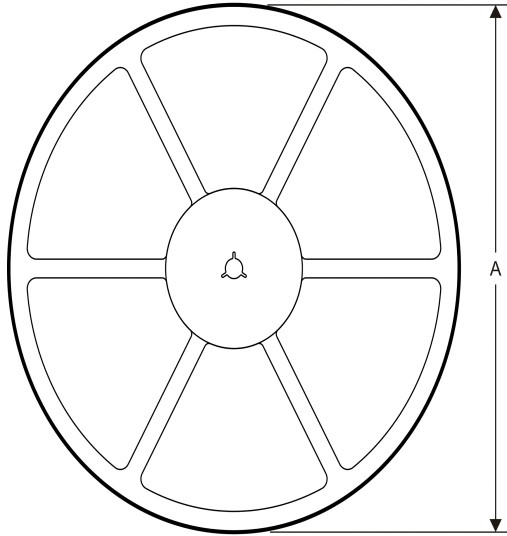
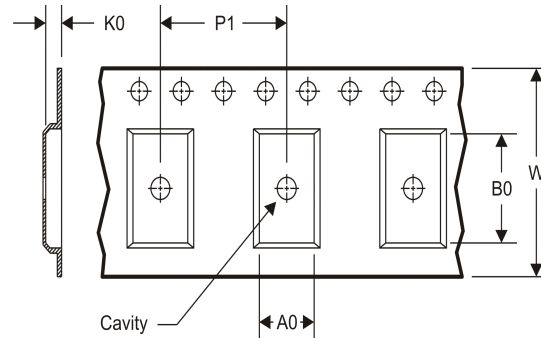
TAPE AND REEL INFORMATION
REEL DIMENSIONS

TAPE DIMENSIONS

A0	Dimension designed to accommodate the component width
B0	Dimension designed to accommodate the component length
K0	Dimension designed to accommodate the component thickness
W	Overall width of the carrier tape
P1	Pitch between successive cavity centers

TAPE AND REEL INFORMATION

*All dimensions are nominal

Device	Package Type	Package Drawing	Pins	SPQ	Reel Diameter (mm)	Reel Width W1 (mm)	A0 (mm)	B0 (mm)	K0 (mm)	P1 (mm)	W (mm)	Pin1 Quadrant
SN74GTLPH16945GR	TSSOP	DGG	48	2000	330.0	24.4	8.6	15.8	1.8	12.0	24.0	Q1

TAPE AND REEL BOX DIMENSIONS



*All dimensions are nominal

Device	Package Type	Package Drawing	Pins	SPQ	Length (mm)	Width (mm)	Height (mm)
SN74GTLPH16945GR	TSSOP	DGG	48	2000	367.0	367.0	45.0

DGG (R-PDSO-G**)

PLASTIC SMALL-OUTLINE PACKAGE

48 PINS SHOWN



- NOTES: A. All linear dimensions are in millimeters.
 B. This drawing is subject to change without notice.
 C. Body dimensions do not include mold protrusion not to exceed 0,15.
 D. Falls within JEDEC MO-153

IMPORTANT NOTICE

Texas Instruments Incorporated and its subsidiaries (TI) reserve the right to make corrections, enhancements, improvements and other changes to its semiconductor products and services per JESD46, latest issue, and to discontinue any product or service per JESD48, latest issue. Buyers should obtain the latest relevant information before placing orders and should verify that such information is current and complete. All semiconductor products (also referred to herein as "components") are sold subject to TI's terms and conditions of sale supplied at the time of order acknowledgment.

TI warrants performance of its components to the specifications applicable at the time of sale, in accordance with the warranty in TI's terms and conditions of sale of semiconductor products. Testing and other quality control techniques are used to the extent TI deems necessary to support this warranty. Except where mandated by applicable law, testing of all parameters of each component is not necessarily performed.

TI assumes no liability for applications assistance or the design of Buyers' products. Buyers are responsible for their products and applications using TI components. To minimize the risks associated with Buyers' products and applications, Buyers should provide adequate design and operating safeguards.

TI does not warrant or represent that any license, either express or implied, is granted under any patent right, copyright, mask work right, or other intellectual property right relating to any combination, machine, or process in which TI components or services are used. Information published by TI regarding third-party products or services does not constitute a license to use such products or services or a warranty or endorsement thereof. Use of such information may require a license from a third party under the patents or other intellectual property of the third party, or a license from TI under the patents or other intellectual property of TI.

Reproduction of significant portions of TI information in TI data books or data sheets is permissible only if reproduction is without alteration and is accompanied by all associated warranties, conditions, limitations, and notices. TI is not responsible or liable for such altered documentation. Information of third parties may be subject to additional restrictions.

Resale of TI components or services with statements different from or beyond the parameters stated by TI for that component or service voids all express and any implied warranties for the associated TI component or service and is an unfair and deceptive business practice. TI is not responsible or liable for any such statements.

Buyer acknowledges and agrees that it is solely responsible for compliance with all legal, regulatory and safety-related requirements concerning its products, and any use of TI components in its applications, notwithstanding any applications-related information or support that may be provided by TI. Buyer represents and agrees that it has all the necessary expertise to create and implement safeguards which anticipate dangerous consequences of failures, monitor failures and their consequences, lessen the likelihood of failures that might cause harm and take appropriate remedial actions. Buyer will fully indemnify TI and its representatives against any damages arising out of the use of any TI components in safety-critical applications.

In some cases, TI components may be promoted specifically to facilitate safety-related applications. With such components, TI's goal is to help enable customers to design and create their own end-product solutions that meet applicable functional safety standards and requirements. Nonetheless, such components are subject to these terms.

No TI components are authorized for use in FDA Class III (or similar life-critical medical equipment) unless authorized officers of the parties have executed a special agreement specifically governing such use.

Only those TI components which TI has specifically designated as military grade or "enhanced plastic" are designed and intended for use in military/aerospace applications or environments. Buyer acknowledges and agrees that any military or aerospace use of TI components which have **not** been so designated is solely at the Buyer's risk, and that Buyer is solely responsible for compliance with all legal and regulatory requirements in connection with such use.

TI has specifically designated certain components as meeting ISO/TS16949 requirements, mainly for automotive use. In any case of use of non-designated products, TI will not be responsible for any failure to meet ISO/TS16949.

Products

Audio	www.ti.com/audio
Amplifiers	amplifier.ti.com
Data Converters	dataconverter.ti.com
DLP® Products	www.dlp.com
DSP	dsp.ti.com
Clocks and Timers	www.ti.com/clocks
Interface	interface.ti.com
Logic	logic.ti.com
Power Mgmt	power.ti.com
Microcontrollers	microcontroller.ti.com
RFID	www.ti-rfid.com
OMAP Applications Processors	www.ti.com/omap
Wireless Connectivity	www.ti.com/wirelessconnectivity

Applications

Automotive and Transportation	www.ti.com/automotive
Communications and Telecom	www.ti.com/communications
Computers and Peripherals	www.ti.com/computers
Consumer Electronics	www.ti.com/consumer-apps
Energy and Lighting	www.ti.com/energy
Industrial	www.ti.com/industrial
Medical	www.ti.com/medical
Security	www.ti.com/security
Space, Avionics and Defense	www.ti.com/space-avionics-defense
Video and Imaging	www.ti.com/video

TI E2E Community

e2e.ti.com