

SN54174, SN54175, SN54LS174, SN54LS175, SN54S174, SN54S175, SN74174, SN74175, SN74LS174, SN74LS175, SN74S174, SN74S175 HEX/QUADRUPLE D-TYPE FLIP-FLOPS WITH CLEAR

SDLS068A – DECEMBER 1972 – REVISED OCTOBER 2001

'174, 'LS174, 'S174 ... HEX D-TYPE FLIP-FLOPS
'175, 'LS175, 'S175 ... QUADRUPLE D-TYPE FLIP-FLOPS

- '174, 'LS174, 'S174 Contain Six Flip-Flops with Single-Rail Outputs
- '175, 'LS175, 'S175 Contain Four Flip-Flops with Double-Rail Outputs
- Three Performance Ranges Offered: See Table Lower Right
- Buffered Clock and Direct Clear Inputs
- Individual Data Input to Each Flip-Flop
- Applications include:
 - Buffer/Storage Registers
 - Shift Registers
 - Pattern Generators

SN54174, SN54LS174, SN54S174 ... J OR W PACKAGE
SN74174 ... N PACKAGE
SN74LS174, SN74S174 ... D OR N PACKAGE

(TOP VIEW)

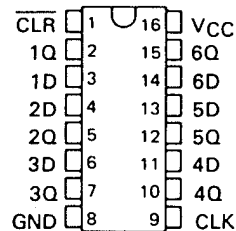

SN54LS174, SN54S174 ... FK PACKAGE

(TOP VIEW)

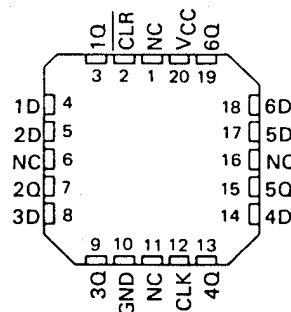

SN54175, SN54LS175, SN54S175 ... J OR W PACKAGE
SN74175 ... N PACKAGE
SN74LS175, SN74S175 ... D OR N PACKAGE

(TOP VIEW)

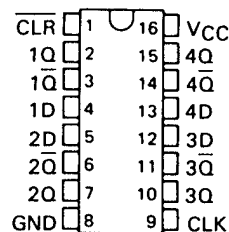

SN54LS175, SN54S175 ... FK PACKAGE

(TOP VIEW)

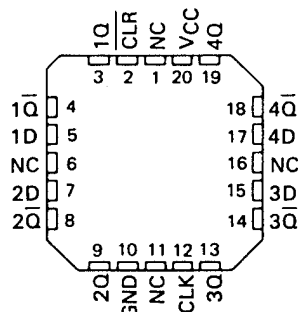

NC – No internal connection

description

These monolithic, positive-edge-triggered flip-flops utilize TTL circuitry to implement D-type flip-flop logic. All have a direct clear input, and the '175, 'LS175, and 'S175 feature complementary outputs from each flip-flop.

Information at the D inputs meeting the setup time requirements is transferred to the Q outputs on the positive-going edge of the clock pulse. Clock triggering occurs at a particular voltage level and is not directly related to the transition time of the positive-going pulse. When the clock input is at either the high or low level, the D input signal has no effect at the output.

These circuits are fully compatible for use with most TTL circuits.

FUNCTION TABLE
(EACH FLIP-FLOP)

| INPUTS | | | OUTPUTS | |
|--------|-------|---|----------------|-----------------|
| CLEAR | CLOCK | D | Q | Q̄† |
| L | X | X | L | H |
| H | ↑ | H | H | L |
| H | ↑ | L | L | H |
| H | L | X | Q ₀ | Q̄ ₀ |

H = high level (steady state)

L = low level (steady state)

X = irrelevant

↑ = transition from low to high level

Q₀ = the level of Q before the indicated steady-state input conditions were established.

† = '175, 'LS175, and 'S175 only

| TYPES | TYPICAL | TYPICAL |
|----------------|-----------|---------------|
| | MAXIMUM | POWER |
| | CLOCK | DISSIPATION |
| | FREQUENCY | PER FLIP-FLOP |
| '174, '175 | 35 MHz | 38 mW |
| 'LS174, 'LS175 | 40 MHz | 14 mW |
| 'S174, 'S175 | 110 MHz | 75 mW |

PRODUCTION DATA information is current as of publication date. Products conform to specifications per the terms of Texas Instruments standard warranty. Production processing does not necessarily include testing of all parameters.

 **TEXAS
INSTRUMENTS**

POST OFFICE BOX 655303 • DALLAS, TEXAS 75265

Copyright © 2001, Texas Instruments Incorporated

SN54174, SN54175, SN54LS174, SN54LS175, SN54S174, SN54S175, SN74174, SN74175, SN74LS174, SN74LS175, SN74S174, SN74S175 HEX/QUADRUPLE D-TYPE FLIP-FLOPS WITH CLEAR

SDLS068A - DECEMBER 1972 - REVISED OCTOBER 2001

logic symbols†

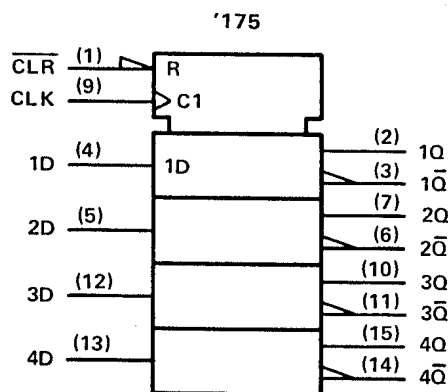
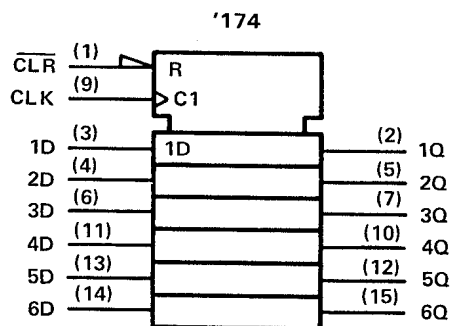

†These symbols are in accordance with ANSI/IEEE Std. 91-1984 and IEC Publication 617-12. Pin numbers shown are for D, J, N, and W packages.

logic diagrams (positive logic)

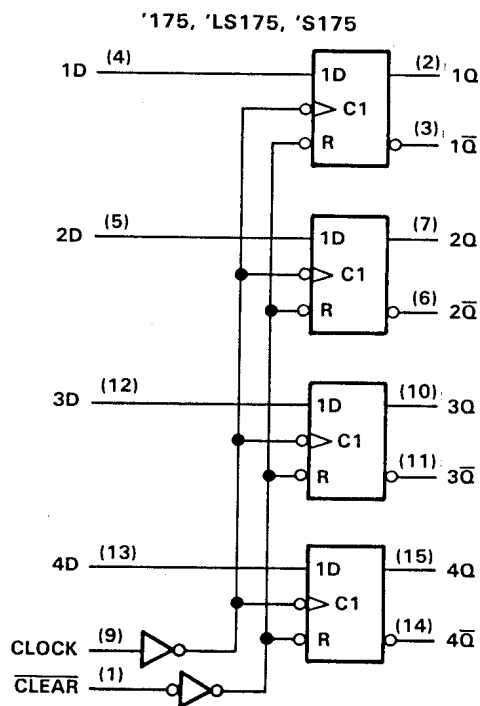
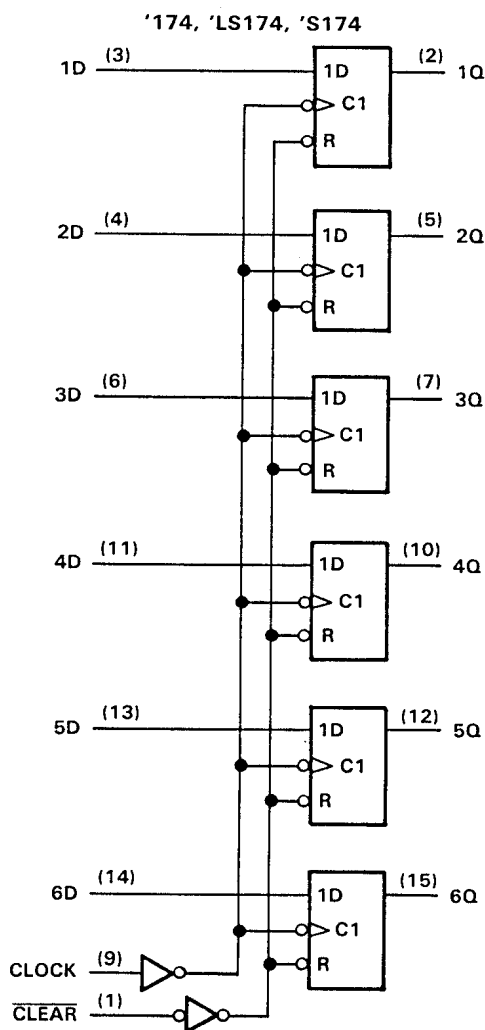

Pin numbers shown are for D, J, N, and W packages.



POST OFFICE BOX 655303 • DALLAS, TEXAS 75265

SN54174, SN54175, SN54LS174, SN54LS175, SN54S174, SN54S175,
 SN74174, SN74175, SN74LS174, SN74LS175, SN74S174, SN74S175
 HEX/QUADRUPLE D-TYPE FLIP-FLOPS WITH CLEAR

SDLS068A - DECEMBER 1972 - REVISED OCTOBER 2001

schematics of inputs and outputs

SN54174, SN54175, SN74174, SN74175

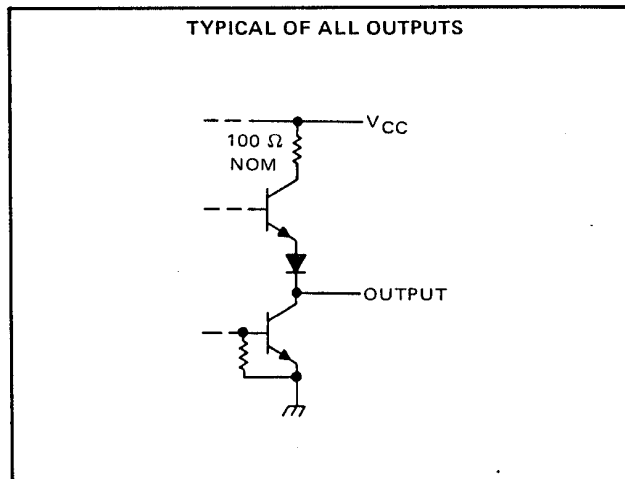
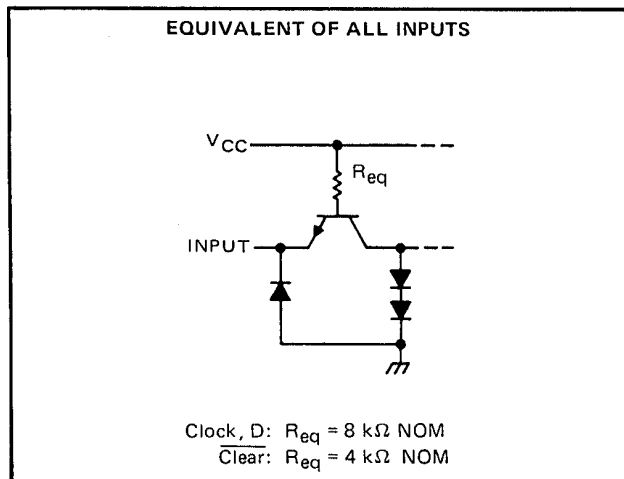

SN54LS174, SN54LS175, SN74LS174, SN74LS175

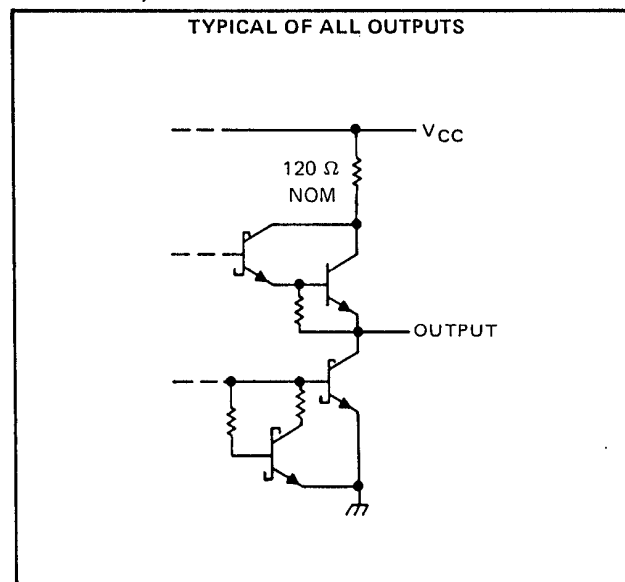
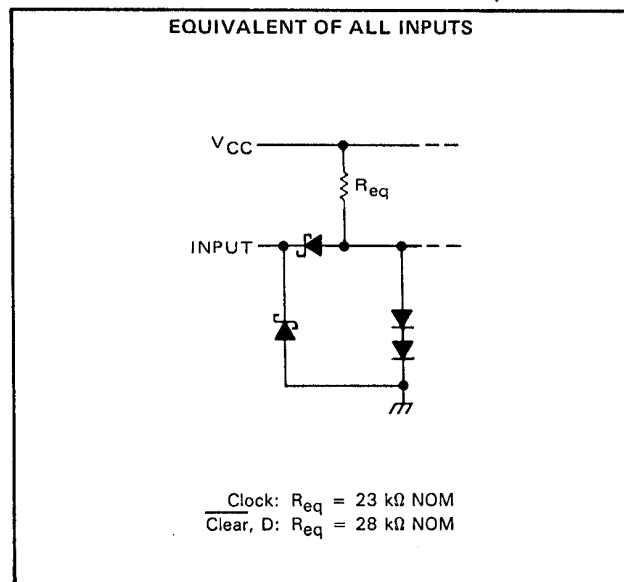

SN54S174, SN54S175, SN74S174, SN74S175

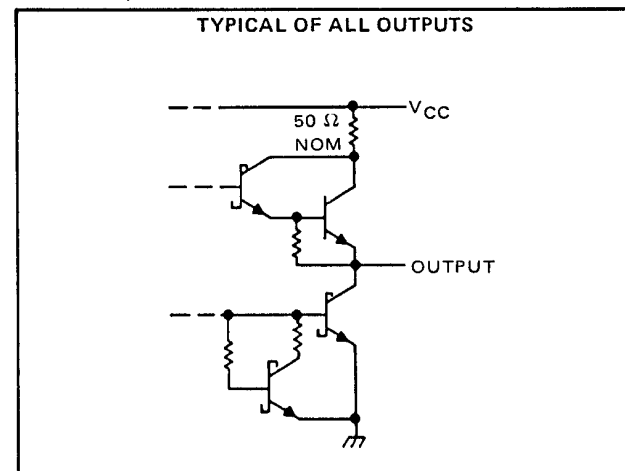
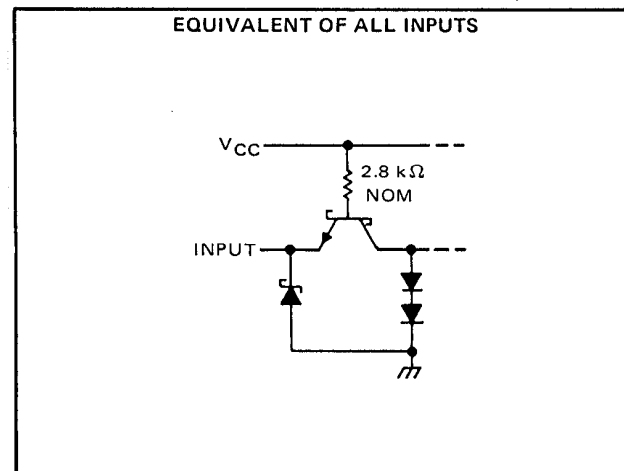

SN54174, SN54175, SN74174, SN74175 HEX/QUADRUPLE D-TYPE FLIP-FLOPS WITH CLEAR

SDLS068A – DECEMBER 1972 – REVISED OCTOBER 2001

absolute maximum ratings over operating free-air temperature range (unless otherwise noted)

| | |
|---|----------------|
| Supply voltage, V_{CC} (see Note 1) | 7 V |
| Input voltage | 5.5 V |
| Operating free-air temperature range: SN54174, SN54175 Circuits | -55°C to 125°C |
| SN74174, SN74175 Circuits | 0°C to 70°C |
| Storage temperature range | -65°C to 150°C |

NOTE 1: Voltage values are with respect to network ground terminal.

recommended operating conditions

| | SN54174, SN54175 | | | SN74174, SN74175 | | | UNIT | | |
|---------------------------------------|----------------------|-----|------|------------------|-----|------|---------|----|----|
| | MIN | NOM | MAX | MIN | NOM | MAX | | | |
| Supply voltage, V_{CC} | 4.5 | 5 | 5.5 | 4.75 | 5 | 5.25 | V | | |
| High-level output current, I_{OH} | | | -800 | | | -800 | μ A | | |
| Low-level output current, I_{OL} | | | 16 | | | 16 | mA | | |
| Clock frequency, f_{clock} | 0 | | 25 | 0 | | 25 | MHz | | |
| Width of clock or clear pulse, t_w | 20 | | | 20 | | | ns | | |
| Setup time, t_{su} | Data input | | | 20 | | | ns | | |
| | Clear inactive-state | | | 25 | | | ns | | |
| Data hold time, t_h | 5 | | | 5 | | | ns | | |
| Operating free-air temperature, T_A | -55 | | | 125 | | | 0 | 70 | °C |

electrical characteristics over recommended operating free-air temperature range (unless otherwise noted)

| PARAMETER | TEST CONDITIONS† | MIN | TYP‡ | MAX | UNIT |
|--|--|-------|------|------|---------|
| V_{IH} High-level input voltage | | 2 | | | V |
| V_{IL} Low-level input voltage | | | | 0.8 | V |
| V_{IK} Input clamp voltage | $V_{CC} = \text{MIN}, I_I = -12 \text{ mA}$ | | | -1.5 | V |
| V_{OH} High-level output voltage | $V_{CC} = \text{MIN}, V_{IH} = 2 \text{ V}, V_{IL} = 0.8 \text{ V}, I_{OH} = -800 \mu\text{A}$ | 2.4 | 3.4 | | V |
| V_{OL} Low-level output voltage | $V_{CC} = \text{MIN}, V_{IH} = 2 \text{ V}, V_{IL} = 0.8 \text{ V}, I_{OL} = 16 \text{ mA}$ | | 0.2 | 0.4 | V |
| I_I Input current at maximum input voltage | $V_{CC} = \text{MAX}, V_I = 5.5 \text{ V}$ | | | 1 | mA |
| I_{IH} High-level input current | $V_{CC} = \text{MAX}, V_I = 2.4 \text{ V}$ | | | 40 | μ A |
| I_{IL} Low-level input current | $V_{CC} = \text{MAX}, V_I = 0.4 \text{ V}$ | | | -1.6 | mA |
| I_{OS} Short-circuit output current§ | $V_{CC} = \text{MAX}$ | SN54' | -20 | -57 | mA |
| | | SN74' | -18 | -57 | |
| I_{CC} Supply current | $V_{CC} = \text{MAX},$ See Note 2 | '174 | 45 | 65 | mA |
| | | '175 | 30 | 45 | |

† For conditions shown as MIN or MAX, use the appropriate value specified under recommended operating conditions for the applicable device type.

‡ All typical values are at $V_{CC} = 5 \text{ V}, T_A = 25^\circ\text{C}$.

§ Not more than one output should be shorted at a time.

NOTE 2: With all outputs open and 4.5 V applied to all data and clear inputs, I_{CC} is measured after a momentary ground, then 4.5 V, is applied to clock.

switching characteristics, $V_{CC} = 5 \text{ V}, T_A = 25^\circ\text{C}$

| PARAMETER | TEST CONDITIONS | MIN | TYP | MAX | UNIT |
|---|--|-----|-----|-----|------|
| f_{max} Maximum clock frequency | | 25 | 35 | | MHz |
| t_{PLH} Propagation delay time, low-to-high-level output from clear (SN54175, SN74175 only) | $C_L = 15 \text{ pF}, R_L = 400 \Omega,$ See Note 3 | | 16 | 25 | ns |
| t_{PHL} Propagation delay time, high-to-low-level output from clear | | | 23 | 35 | ns |
| t_{PLH} Propagation delay time, low-to-high-level output from clock | | | 20 | 30 | ns |
| t_{PHL} Propagation delay time, high-to-low-level output from clock | | | 24 | 35 | ns |

NOTE 3: Load circuits and voltage waveforms are shown in Section 1.



POST OFFICE BOX 655303 • DALLAS, TEXAS 75265

SN54LS174, SN54LS175, SN74LS174, SN74LS175 HEX/QUADRUPLE D-TYPE FLIP-FLOPS WITH CLEAR

SDLS068A – DECEMBER 1972 – REVISED OCTOBER 2001

absolute maximum ratings over operating free-air temperature range (unless otherwise noted)

| | |
|---|----------------|
| Supply voltage, V_{CC} (see Note 1) | 7 V |
| Input voltage | 7 V |
| Operating free-air temperature range: SN54LS174, SN54LS175 Circuits | -55°C to 125°C |
| SN74LS174, SN74LS175 Circuits | 0°C to 70°C |
| Storage temperature range | -65°C to 150°C |

NOTE 1: Voltage values are with respect to network ground terminal.

recommended operating conditions

| | SN54LS174 SN54LS175 | | | SN74LS174 SN74LS175 | | | UNIT |
|---------------------------------------|------------------------|-----|------|------------------------|-----|------|---------|
| | MIN | NOM | MAX | MIN | NOM | MAX | |
| Supply voltage, V_{CC} | 4.5 | 5 | 5.5 | 4.75 | 5 | 5.25 | V |
| High-level output current, I_{OH} | | | -400 | | | -400 | μ A |
| Low-level output current, I_{OL} | | | 4 | | | 8 | mA |
| Clock frequency, f_{clock} | 0 | | 30 | 0 | | 30 | MHz |
| Width of clock or clear pulse, t_W | 20 | | | 20 | | | ns |
| Setup time, t_{su} | Data input | 20 | | 20 | | | ns |
| | Clear inactive-state | 25 | | 25 | | | ns |
| Data hold time, t_h | 5 | | | 5 | | | ns |
| Operating free-air temperature, T_A | -55 | | 125 | 0 | | 70 | °C |

electrical characteristics over recommended operating free-air temperature range (unless otherwise noted)

| PARAMETER | TEST CONDITIONS† | SN54LS174 SN54LS175 | | | SN74LS174 SN74LS175 | | | UNIT |
|--|--|-------------------------|------|------|------------------------|------|------|---------|
| | | MIN | TYP‡ | MAX | MIN | TYP‡ | MAX | |
| V_{IH} High-level input voltage | | 2 | | | 2 | | | V |
| V_{IL} Low-level input voltage | | | | 0.7 | | | 0.8 | V |
| V_{IK} Input clamp voltage | $V_{CC} = \text{MIN}, I_I = -18 \text{ mA}$ | | | -1.5 | | | -1.5 | V |
| V_{OH} High-level output voltage | $V_{CC} = \text{MIN}, V_{IH} = 2 \text{ V},$ $V_{IL} = V_{IL \text{ max}}, I_{OH} = -400 \mu\text{A}$ | 2.5 | 3.5 | | 2.7 | 3.5 | | V |
| V_{OL} Low-level output voltage | $V_{CC} = \text{MIN}, V_{IH} = 2 \text{ V},$ $V_{IL} = V_{IL \text{ max}}$ | $I_{OL} = 4 \text{ mA}$ | 0.25 | 0.4 | 0.25 | 0.4 | | V |
| | | $I_{OL} = 8 \text{ mA}$ | | | 0.35 | 0.5 | | |
| I_I Input current at maximum input voltage | $V_{CC} = \text{MAX}, V_I = 7 \text{ V}$ | | | 0.1 | | | 0.1 | mA |
| I_{IH} High-level input current | $V_{CC} = \text{MAX}, V_I = 2.7 \text{ V}$ | | | 20 | | | 20 | μ A |
| I_{IL} Low-level input current | $V_{CC} = \text{MAX}, V_I = 0.4 \text{ V}$ | | | -0.4 | | | -0.4 | mA |
| I_{OS} Short-circuit output current § | $V_{CC} = \text{MAX}$ | -20 | | -100 | -20 | | -100 | mA |
| I_{CC} Supply current | $V_{CC} = \text{MAX},$ See Note 2 | 'LS174 | 16 | 26 | 16 | 26 | | mA |
| | | 'LS175 | 11 | 18 | 11 | 18 | | |

† For conditions shown as MIN or MAX, use the appropriate value specified under recommended operating conditions.

‡ All typical values are at $V_{CC} = 5 \text{ V}, T_A = 25^\circ\text{C}$.

§ Not more than one output should be shorted at a time, and duration of the short-circuit should not exceed one second.

NOTE 2: With all outputs open and 4.5 V applied to all data and clear inputs, I_{CC} is measured after a momentary ground, then 4.5 V, is applied to clock.

switching characteristics, $V_{CC} = 5 \text{ V}, T_A = 25^\circ\text{C}$

| PARAMETER | TEST CONDITIONS | 'LS174 | | | 'LS175 | | | UNIT |
|---|--|--------|-----|-----|--------|-----|-----|------|
| | | MIN | TYP | MAX | MIN | TYP | MAX | |
| f_{max} Maximum clock frequency | $C_L = 15 \text{ pF},$ $R_L = 2 \text{ k}\Omega,$ See Note 3 | 30 | 40 | | 30 | 40 | | MHz |
| t_{PLH} Propagation delay time, low-to-high-level output from clear | | | | | 20 | 30 | | ns |
| t_{PHL} Propagation delay time, high-to-low-level output from clear | | | 23 | 35 | 20 | 30 | | ns |
| t_{PLH} Propagation delay time, low-to-high-level output from clock | | | 20 | 30 | 13 | 25 | | ns |
| t_{PHL} Propagation delay time, high-to-low-level output from clock | | | 21 | 30 | 16 | 25 | | ns |

NOTE 3: Load circuits and voltage waveforms are shown in Section 1.



SN54S174, SN54S175, SN74S174, SN74S175 HEX/QUADRUPLE D-TYPE FLIP-FLOPS WITH CLEAR

SDLS068A – DECEMBER 1972 – REVISED OCTOBER 2001

absolute maximum ratings over operating free-air temperature range (unless otherwise noted)

| | |
|---|----------------|
| Supply voltage, V_{CC} (see Note 1) | 7 V |
| Input voltage | 5.5 V |
| Operating free-air temperature range: SN54S174, SN54S175 Circuits | -55°C to 125°C |
| SN74S174, SN74S175 Circuits | 0°C to 70°C |
| Storage temperature range | -65°C to 150°C |

NOTE 1: Voltage values are with respect to network ground terminal.

recommended operating conditions

| | SN54S174, SN54S175 | | | SN74S174, SN74S175 | | | UNIT |
|---------------------------------------|----------------------|-----|-----|--------------------|-----|------|------|
| | MIN | NOM | MAX | MIN | NOM | MAX | |
| Supply voltage, V_{CC} | 4.5 | 5 | 5.5 | 4.75 | 5 | 5.25 | V |
| High-level output current, I_{OH} | | | -1 | | | -1 | mA |
| Low-level output current, I_{OL} | | | 20 | | | 20 | mA |
| Clock frequency, f_{clock} | 0 | | 75 | 0 | | 75 | MHz |
| Pulse width, t_w | Clock | | 7 | | | 7 | ns |
| | Clear | | 10 | | | 10 | |
| Setup time, t_{su} | Data input | | 5 | | | 5 | ns |
| | Clear inactive-state | | 5 | | | 5 | |
| Data hold time, t_h | | | 3 | | | 3 | ns |
| Operating free-air temperature, T_A | -55 | | 125 | 0 | | 70 | °C |

electrical characteristics over recommended operating free-air temperature range (unless otherwise noted)

| PARAMETER | TEST CONDITIONS† | MIN | TYP‡ | MAX | UNIT |
|--|--|--------|------|------|------|
| V_{IH} High-level input voltage | | 2 | | | V |
| V_{IL} Low-level input voltage | | | | 0.8 | V |
| V_{IK} Input clamp voltage | $V_{CC} = \text{MIN}, I_I = -18 \text{ mA}$ | | | -1.2 | V |
| V_{OH} High-level output voltage | $V_{CC} = \text{MIN}, V_{IH} = 2 \text{ V},$ $V_{IL} = 0.8 \text{ V}, I_{OH} = -1 \text{ mA}$ | SN54S' | 2.5 | 3.4 | V |
| | | SN74S' | 2.7 | 3.4 | |
| V_{OL} Low-level output voltage | $V_{CC} = \text{MIN}, V_{IH} = 2 \text{ V},$ $V_{IL} = 0.8 \text{ V}, I_{OL} = 20 \text{ mA}$ | | | 0.5 | V |
| I_I Input current at maximum input voltage | $V_{CC} = \text{MAX}, V_I = 5.5 \text{ V}$ | | | 1 | mA |
| I_{IH} High-level input current | $V_{CC} = \text{MAX}, V_I = 2.7 \text{ V}$ | | | 50 | µA |
| I_{IL} Low-level input current | $V_{CC} = \text{MAX}, V_I = 0.5 \text{ V}$ | | | -2 | mA |
| I_{OS} Short-circuit output current § | $V_{CC} = \text{MAX}$ | -40 | | -100 | mA |
| I_{CC} Supply current | $V_{CC} = \text{MAX}, \text{ See Note 2}$ | '174 | 90 | 144 | mA |
| | | '175 | 60 | 96 | |

† For conditions shown as MIN or MAX, use the appropriate value specified under recommended operating conditions for the applicable device type.

‡ All typical values are at $V_{CC} = 5 \text{ V}, T_A = 25^\circ\text{C}$.

§ Not more than one output should be shorted at a time, and duration of the short-circuit should not exceed one second.

NOTE 2: With all outputs open and 4.5 V applied to all data and clear inputs, I_{CC} is measured after a momentary ground, then 4.5 V, is applied to clock.

switching characteristics, $V_{CC} = 5 \text{ V}, T_A = 25^\circ\text{C}$

| PARAMETER | TEST CONDITIONS | MIN | TYP | MAX | UNIT |
|---|---|-----|------|-----|------|
| f_{max} Maximum clock frequency | | 75 | 110 | | MHz |
| t_{PLH} Propagation delay time, low-to-high-level \bar{Q} output from clear (SN54S175, SN74S175 only) | $C_L = 15 \text{ pF},$ $R_L = 280 \Omega,$ See Note 3 | | 10 | 15 | ns |
| t_{PHL} Propagation delay time, high-to-low-level Q output from clear | | | 13 | 22 | ns |
| t_{PLH} Propagation delay time, low-to-high-level output from clock | | | 8 | 12 | ns |
| t_{PHL} Propagation time, high-to-low-level output from clock | | | 11.5 | 17 | ns |

NOTE 3: Load circuits and voltage waveforms are shown in Section 1.



PACKAGING INFORMATION

| Orderable Device | Status (1) | Package Type | Package Drawing | Pins | Package Qty | Eco Plan (2) | Lead/Ball Finish (6) | MSL Peak Temp (3) | Op Temp (°C) | Device Marking (4/5) | Samples |
|------------------|---------------|--------------|--------------------|------|----------------|-----------------|-------------------------|----------------------|--------------|-------------------------|-------------------------|
| JM38510/01702BEA | OBSOLETE | CDIP | J | 16 | | TBD | Call TI | Call TI | -55 to 125 | | |
| JM38510/01702BFA | OBSOLETE | CFP | W | 16 | | TBD | Call TI | Call TI | -55 to 125 | | |
| JM38510/07105BEA | ACTIVE | CDIP | J | 16 | 1 | TBD | A42 | N / A for Pkg Type | -55 to 125 | JM38510/ 07105BEA | Samples |
| JM38510/07105BFA | ACTIVE | CFP | W | 16 | 1 | TBD | A42 | N / A for Pkg Type | -55 to 125 | JM38510/ 07105BFA | Samples |
| JM38510/07106BEA | ACTIVE | CDIP | J | 16 | 1 | TBD | A42 | N / A for Pkg Type | -55 to 125 | JM38510/ 07106BEA | Samples |
| JM38510/30106B2A | ACTIVE | LCCC | FK | 20 | 1 | TBD | POST-PLATE | N / A for Pkg Type | -55 to 125 | JM38510/ 30106B2A | Samples |
| JM38510/30106BEA | ACTIVE | CDIP | J | 16 | 1 | TBD | A42 | N / A for Pkg Type | -55 to 125 | JM38510/ 30106BEA | Samples |
| JM38510/30106BFA | ACTIVE | CFP | W | 16 | 1 | TBD | A42 | N / A for Pkg Type | -55 to 125 | JM38510/ 30106BFA | Samples |
| JM38510/30107B2A | ACTIVE | LCCC | FK | 20 | 1 | TBD | POST-PLATE | N / A for Pkg Type | -55 to 125 | JM38510/ 30107B2A | Samples |
| JM38510/30107BEA | ACTIVE | CDIP | J | 16 | 1 | TBD | A42 | N / A for Pkg Type | -55 to 125 | JM38510/ 30107BEA | Samples |
| JM38510/30107BFA | ACTIVE | CFP | W | 16 | 1 | TBD | A42 | N / A for Pkg Type | -55 to 125 | JM38510/ 30107BFA | Samples |
| JM38510/30107SEA | OBSOLETE | CDIP | J | 16 | | TBD | Call TI | Call TI | -55 to 125 | JM38510/ 30107SEA | |
| JM38510/30107SFA | OBSOLETE | CFP | W | 16 | | TBD | Call TI | Call TI | -55 to 125 | JM38510/ 30107SFA | |
| M38510/07105BEA | ACTIVE | CDIP | J | 16 | 1 | TBD | A42 | N / A for Pkg Type | -55 to 125 | JM38510/ 07105BEA | Samples |
| M38510/07105BFA | ACTIVE | CFP | W | 16 | 1 | TBD | A42 | N / A for Pkg Type | -55 to 125 | JM38510/ 07105BFA | Samples |
| M38510/07106BEA | ACTIVE | CDIP | J | 16 | 1 | TBD | A42 | N / A for Pkg Type | -55 to 125 | JM38510/ 07106BEA | Samples |
| M38510/30106B2A | ACTIVE | LCCC | FK | 20 | 1 | TBD | POST-PLATE | N / A for Pkg Type | -55 to 125 | JM38510/ 30106B2A | Samples |
| M38510/30106BEA | ACTIVE | CDIP | J | 16 | 1 | TBD | A42 | N / A for Pkg Type | -55 to 125 | JM38510/ 30106BEA | Samples |

| Orderable Device | Status (1) | Package Type | Package Drawing | Pins | Package Qty | Eco Plan (2) | Lead/Ball Finish (6) | MSL Peak Temp (3) | Op Temp (°C) | Device Marking (4/5) | Samples |
|------------------|---------------|--------------|-----------------|------|-------------|----------------------------|-------------------------|----------------------|--------------|-------------------------|-------------------------|
| M38510/30106BFA | ACTIVE | CFP | W | 16 | 1 | TBD | A42 | N / A for Pkg Type | -55 to 125 | JM38510/ 30106BFA | Samples |
| M38510/30107B2A | ACTIVE | LCCC | FK | 20 | 1 | TBD | POST-PLATE | N / A for Pkg Type | -55 to 125 | JM38510/ 30107B2A | Samples |
| M38510/30107BEA | ACTIVE | CDIP | J | 16 | 1 | TBD | A42 | N / A for Pkg Type | -55 to 125 | JM38510/ 30107BEA | Samples |
| M38510/30107BFA | ACTIVE | CFP | W | 16 | 1 | TBD | A42 | N / A for Pkg Type | -55 to 125 | JM38510/ 30107BFA | Samples |
| M38510/30107SEA | OBSOLETE | CDIP | J | 16 | | TBD | Call TI | Call TI | -55 to 125 | JM38510/ 30107SEA | |
| M38510/30107SFA | OBSOLETE | CFP | W | 16 | | TBD | Call TI | Call TI | -55 to 125 | JM38510/ 30107SFA | |
| SN54175J | OBSOLETE | CDIP | J | 16 | | TBD | Call TI | Call TI | -55 to 125 | | |
| SN54LS174J | ACTIVE | CDIP | J | 16 | 1 | TBD | A42 | N / A for Pkg Type | -55 to 125 | SN54LS174J | Samples |
| SN54LS175J | ACTIVE | CDIP | J | 16 | 1 | TBD | A42 | N / A for Pkg Type | -55 to 125 | SN54LS175J | Samples |
| SN54S174J | ACTIVE | CDIP | J | 16 | 1 | TBD | A42 | N / A for Pkg Type | -55 to 125 | SN54S174J | Samples |
| SN54S175J | ACTIVE | CDIP | J | 16 | 1 | TBD | A42 | N / A for Pkg Type | -55 to 125 | SN54S175J | Samples |
| SN74174N | OBSOLETE | PDIP | N | 16 | | TBD | Call TI | Call TI | 0 to 70 | | |
| SN74175N | OBSOLETE | PDIP | N | 16 | | TBD | Call TI | Call TI | 0 to 70 | | |
| SN74175N3 | OBSOLETE | PDIP | N | 16 | | TBD | Call TI | Call TI | 0 to 70 | | |
| SN74LS174D | ACTIVE | SOIC | D | 16 | 40 | Green (RoHS & no Sb/Br) | CU NIPDAU | Level-1-260C-UNLIM | 0 to 70 | LS174 | Samples |
| SN74LS174DG4 | ACTIVE | SOIC | D | 16 | 40 | Green (RoHS & no Sb/Br) | CU NIPDAU | Level-1-260C-UNLIM | 0 to 70 | LS174 | Samples |
| SN74LS174DR | ACTIVE | SOIC | D | 16 | 2500 | Green (RoHS & no Sb/Br) | CU NIPDAU | Level-1-260C-UNLIM | 0 to 70 | LS174 | Samples |
| SN74LS174J | OBSOLETE | CDIP | J | 16 | | TBD | Call TI | Call TI | 0 to 70 | | |
| SN74LS174N | ACTIVE | PDIP | N | 16 | 25 | Pb-Free (RoHS) | CU NIPDAU | N / A for Pkg Type | 0 to 70 | SN74LS174N | Samples |
| SN74LS174N3 | OBSOLETE | PDIP | N | 16 | | TBD | Call TI | Call TI | 0 to 70 | | |
| SN74LS174NE4 | ACTIVE | PDIP | N | 16 | 25 | Pb-Free (RoHS) | CU NIPDAU | N / A for Pkg Type | 0 to 70 | SN74LS174N | Samples |

| Orderable Device | Status (1) | Package Type | Package Drawing | Pins | Package Qty | Eco Plan (2) | Lead/Ball Finish (6) | MSL Peak Temp (3) | Op Temp (°C) | Device Marking (4/5) | Samples |
|------------------|---------------|--------------|-----------------|------|-------------|-------------------------|-------------------------|----------------------|--------------|-------------------------|-------------------------|
| SN74LS174NSR | ACTIVE | SO | NS | 16 | 2000 | Green (RoHS & no Sb/Br) | CU NIPDAU | Level-1-260C-UNLIM | 0 to 70 | 74LS174 | Samples |
| SN74LS175D | ACTIVE | SOIC | D | 16 | 40 | Green (RoHS & no Sb/Br) | CU NIPDAU | Level-1-260C-UNLIM | 0 to 70 | LS175 | Samples |
| SN74LS175DG4 | ACTIVE | SOIC | D | 16 | 40 | Green (RoHS & no Sb/Br) | CU NIPDAU | Level-1-260C-UNLIM | 0 to 70 | LS175 | Samples |
| SN74LS175DR | ACTIVE | SOIC | D | 16 | 2500 | Green (RoHS & no Sb/Br) | CU NIPDAU | Level-1-260C-UNLIM | 0 to 70 | LS175 | Samples |
| SN74LS175J | OBSOLETE | CDIP | J | 16 | | TBD | Call TI | Call TI | 0 to 70 | | |
| SN74LS175N | ACTIVE | PDIP | N | 16 | 25 | Pb-Free (RoHS) | CU NIPDAU | N / A for Pkg Type | 0 to 70 | SN74LS175N | Samples |
| SN74LS175N3 | OBSOLETE | PDIP | N | 16 | | TBD | Call TI | Call TI | 0 to 70 | | |
| SN74LS175NE4 | ACTIVE | PDIP | N | 16 | 25 | Pb-Free (RoHS) | CU NIPDAU | N / A for Pkg Type | 0 to 70 | SN74LS175N | Samples |
| SN74LS175NSR | ACTIVE | SO | NS | 16 | 2000 | Green (RoHS & no Sb/Br) | CU NIPDAU | Level-1-260C-UNLIM | 0 to 70 | 74LS175 | Samples |
| SN74S174J | OBSOLETE | CDIP | J | 16 | | TBD | Call TI | Call TI | 0 to 70 | | |
| SN74S174N | OBSOLETE | PDIP | N | 16 | | TBD | Call TI | Call TI | 0 to 70 | SN74S174N | |
| SN74S174N3 | OBSOLETE | PDIP | N | 16 | | TBD | Call TI | Call TI | 0 to 70 | | |
| SN74S175D | ACTIVE | SOIC | D | 16 | 40 | Green (RoHS & no Sb/Br) | CU NIPDAU | Level-1-260C-UNLIM | 0 to 70 | S175 | Samples |
| SN74S175DR | OBSOLETE | SOIC | D | 16 | | TBD | Call TI | Call TI | 0 to 70 | | |
| SN74S175N | ACTIVE | PDIP | N | 16 | 25 | Pb-Free (RoHS) | CU NIPDAU | N / A for Pkg Type | 0 to 70 | SN74S175N | Samples |
| SN74S175N3 | OBSOLETE | PDIP | N | 16 | | TBD | Call TI | Call TI | 0 to 70 | | |
| SN74S175NE4 | ACTIVE | PDIP | N | 16 | 25 | Pb-Free (RoHS) | CU NIPDAU | N / A for Pkg Type | 0 to 70 | SN74S175N | Samples |
| SNJ54175J | OBSOLETE | CDIP | J | 16 | | TBD | Call TI | Call TI | -55 to 125 | | |
| SNJ54175W | OBSOLETE | CFP | W | 16 | | TBD | Call TI | Call TI | -55 to 125 | | |
| SNJ54LS174FK | ACTIVE | LCCC | FK | 20 | 1 | TBD | POST-PLATE | N / A for Pkg Type | -55 to 125 | SNJ54LS174FK | Samples |
| SNJ54LS174J | ACTIVE | CDIP | J | 16 | 1 | TBD | A42 | N / A for Pkg Type | -55 to 125 | SNJ54LS174J | Samples |
| SNJ54LS174W | ACTIVE | CFP | W | 16 | 1 | TBD | A42 | N / A for Pkg Type | -55 to 125 | SNJ54LS174W | Samples |

| Orderable Device | Status (1) | Package Type | Package Drawing | Pins | Package Qty | Eco Plan (2) | Lead/Ball Finish (6) | MSL Peak Temp (3) | Op Temp (°C) | Device Marking (4/5) | Samples |
|------------------|---------------|--------------|-----------------|------|-------------|-----------------|-------------------------|----------------------|--------------|-------------------------|-------------------------|
| SNJ54LS175FK | ACTIVE | LCCC | FK | 20 | 1 | TBD | POST-PLATE | N / A for Pkg Type | -55 to 125 | SNJ54LS 175FK | Samples |
| SNJ54LS175J | ACTIVE | CDIP | J | 16 | 1 | TBD | A42 | N / A for Pkg Type | -55 to 125 | SNJ54LS175J | Samples |
| SNJ54LS175W | ACTIVE | CFP | W | 16 | 1 | TBD | A42 | N / A for Pkg Type | -55 to 125 | SNJ54LS175W | Samples |
| SNJ54S174FK | NRND | LCCC | FK | 20 | 1 | TBD | POST-PLATE | N / A for Pkg Type | -55 to 125 | SNJ54S 174FK | |
| SNJ54S174J | ACTIVE | CDIP | J | 16 | 1 | TBD | A42 | N / A for Pkg Type | -55 to 125 | SNJ54S174J | Samples |
| SNJ54S174W | ACTIVE | CFP | W | 16 | 1 | TBD | A42 | N / A for Pkg Type | -55 to 125 | SNJ54S174W | Samples |
| SNJ54S175FK | OBSOLETE | LCCC | FK | 20 | | TBD | Call TI | Call TI | -55 to 125 | SNJ54S 175FK | |
| SNJ54S175J | ACTIVE | CDIP | J | 16 | 1 | TBD | A42 | N / A for Pkg Type | -55 to 125 | SNJ54S175J | Samples |
| SNJ54S175W | OBSOLETE | CFP | W | 16 | | TBD | Call TI | Call TI | -55 to 125 | SNJ54S175W | |

(1) The marketing status values are defined as follows:

ACTIVE: Product device recommended for new designs.

LIFEBUY: TI has announced that the device will be discontinued, and a lifetime-buy period is in effect.

NRND: Not recommended for new designs. Device is in production to support existing customers, but TI does not recommend using this part in a new design.

PREVIEW: Device has been announced but is not in production. Samples may or may not be available.

OBSOLETE: TI has discontinued the production of the device.

(2) Eco Plan - The planned eco-friendly classification: Pb-Free (RoHS), Pb-Free (RoHS Exempt), or Green (RoHS & no Sb/Br) - please check <http://www.ti.com/productcontent> for the latest availability information and additional product content details.

TBD: The Pb-Free/Green conversion plan has not been defined.

Pb-Free (RoHS): TI's terms "Lead-Free" or "Pb-Free" mean semiconductor products that are compatible with the current RoHS requirements for all 6 substances, including the requirement that lead not exceed 0.1% by weight in homogeneous materials. Where designed to be soldered at high temperatures, TI Pb-Free products are suitable for use in specified lead-free processes.

Pb-Free (RoHS Exempt): This component has a RoHS exemption for either 1) lead-based flip-chip solder bumps used between the die and package, or 2) lead-based die adhesive used between the die and leadframe. The component is otherwise considered Pb-Free (RoHS compatible) as defined above.

Green (RoHS & no Sb/Br): TI defines "Green" to mean Pb-Free (RoHS compatible), and free of Bromine (Br) and Antimony (Sb) based flame retardants (Br or Sb do not exceed 0.1% by weight in homogeneous material)

(3) MSL, Peak Temp. - The Moisture Sensitivity Level rating according to the JEDEC industry standard classifications, and peak solder temperature.

(4) There may be additional marking, which relates to the logo, the lot trace code information, or the environmental category on the device.

⁽⁵⁾ Multiple Device Markings will be inside parentheses. Only one Device Marking contained in parentheses and separated by a "-" will appear on a device. If a line is indented then it is a continuation of the previous line and the two combined represent the entire Device Marking for that device.

⁽⁶⁾ Lead/Ball Finish - Orderable Devices may have multiple material finish options. Finish options are separated by a vertical ruled line. Lead/Ball Finish values may wrap to two lines if the finish value exceeds the maximum column width.

Important Information and Disclaimer:The information provided on this page represents TI's knowledge and belief as of the date that it is provided. TI bases its knowledge and belief on information provided by third parties, and makes no representation or warranty as to the accuracy of such information. Efforts are underway to better integrate information from third parties. TI has taken and continues to take reasonable steps to provide representative and accurate information but may not have conducted destructive testing or chemical analysis on incoming materials and chemicals. TI and TI suppliers consider certain information to be proprietary, and thus CAS numbers and other limited information may not be available for release.

In no event shall TI's liability arising out of such information exceed the total purchase price of the TI part(s) at issue in this document sold by TI to Customer on an annual basis.

OTHER QUALIFIED VERSIONS OF SN54175, SN54LS174, SN54LS175, SN54LS175-SP, SN54S174, SN54S175, SN74175, SN74LS174, SN74LS175, SN74S174, SN74S175 :

- Catalog: [SN74175](#), [SN74LS174](#), [SN74LS175](#), [SN54LS175](#), [SN74S174](#), [SN74S175](#)
- Military: [SN54175](#), [SN54LS174](#), [SN54LS175](#), [SN54S174](#), [SN54S175](#)
- Space: [SN54LS175-SP](#)

NOTE: Qualified Version Definitions:

- Catalog - TI's standard catalog product
- Military - QML certified for Military and Defense Applications
- Space - Radiation tolerant, ceramic packaging and qualified for use in Space-based application

TAPE AND REEL INFORMATION
REEL DIMENSIONS

TAPE DIMENSIONS

| | |
|----|---|
| A0 | Dimension designed to accommodate the component width |
| B0 | Dimension designed to accommodate the component length |
| K0 | Dimension designed to accommodate the component thickness |
| W | Overall width of the carrier tape |
| P1 | Pitch between successive cavity centers |

TAPE AND REEL INFORMATION

*All dimensions are nominal

| Device | Package Type | Package Drawing | Pins | SPQ | Reel Diameter (mm) | Reel Width W1 (mm) | A0 (mm) | B0 (mm) | K0 (mm) | P1 (mm) | W (mm) | Pin1 Quadrant |
|--------------|--------------|-----------------|------|------|--------------------|--------------------|---------|---------|---------|---------|--------|---------------|
| SN74LS174DR | SOIC | D | 16 | 2500 | 330.0 | 16.4 | 6.5 | 10.3 | 2.1 | 8.0 | 16.0 | Q1 |
| SN74LS174NSR | SO | NS | 16 | 2000 | 330.0 | 16.4 | 8.2 | 10.5 | 2.5 | 12.0 | 16.0 | Q1 |
| SN74LS175DR | SOIC | D | 16 | 2500 | 330.0 | 16.4 | 6.5 | 10.3 | 2.1 | 8.0 | 16.0 | Q1 |
| SN74LS175NSR | SO | NS | 16 | 2000 | 330.0 | 16.4 | 8.2 | 10.5 | 2.5 | 12.0 | 16.0 | Q1 |

TAPE AND REEL BOX DIMENSIONS

*All dimensions are nominal

| Device | Package Type | Package Drawing | Pins | SPQ | Length (mm) | Width (mm) | Height (mm) |
|--------------|--------------|-----------------|------|------|-------------|------------|-------------|
| SN74LS174DR | SOIC | D | 16 | 2500 | 333.2 | 345.9 | 28.6 |
| SN74LS174NSR | SO | NS | 16 | 2000 | 367.0 | 367.0 | 38.0 |
| SN74LS175DR | SOIC | D | 16 | 2500 | 333.2 | 345.9 | 28.6 |
| SN74LS175NSR | SO | NS | 16 | 2000 | 367.0 | 367.0 | 38.0 |

IMPORTANT NOTICE

Texas Instruments Incorporated and its subsidiaries (TI) reserve the right to make corrections, enhancements, improvements and other changes to its semiconductor products and services per JESD46, latest issue, and to discontinue any product or service per JESD48, latest issue. Buyers should obtain the latest relevant information before placing orders and should verify that such information is current and complete. All semiconductor products (also referred to herein as "components") are sold subject to TI's terms and conditions of sale supplied at the time of order acknowledgment.

TI warrants performance of its components to the specifications applicable at the time of sale, in accordance with the warranty in TI's terms and conditions of sale of semiconductor products. Testing and other quality control techniques are used to the extent TI deems necessary to support this warranty. Except where mandated by applicable law, testing of all parameters of each component is not necessarily performed.

TI assumes no liability for applications assistance or the design of Buyers' products. Buyers are responsible for their products and applications using TI components. To minimize the risks associated with Buyers' products and applications, Buyers should provide adequate design and operating safeguards.

TI does not warrant or represent that any license, either express or implied, is granted under any patent right, copyright, mask work right, or other intellectual property right relating to any combination, machine, or process in which TI components or services are used. Information published by TI regarding third-party products or services does not constitute a license to use such products or services or a warranty or endorsement thereof. Use of such information may require a license from a third party under the patents or other intellectual property of the third party, or a license from TI under the patents or other intellectual property of TI.

Reproduction of significant portions of TI information in TI data books or data sheets is permissible only if reproduction is without alteration and is accompanied by all associated warranties, conditions, limitations, and notices. TI is not responsible or liable for such altered documentation. Information of third parties may be subject to additional restrictions.

Resale of TI components or services with statements different from or beyond the parameters stated by TI for that component or service voids all express and any implied warranties for the associated TI component or service and is an unfair and deceptive business practice. TI is not responsible or liable for any such statements.

Buyer acknowledges and agrees that it is solely responsible for compliance with all legal, regulatory and safety-related requirements concerning its products, and any use of TI components in its applications, notwithstanding any applications-related information or support that may be provided by TI. Buyer represents and agrees that it has all the necessary expertise to create and implement safeguards which anticipate dangerous consequences of failures, monitor failures and their consequences, lessen the likelihood of failures that might cause harm and take appropriate remedial actions. Buyer will fully indemnify TI and its representatives against any damages arising out of the use of any TI components in safety-critical applications.

In some cases, TI components may be promoted specifically to facilitate safety-related applications. With such components, TI's goal is to help enable customers to design and create their own end-product solutions that meet applicable functional safety standards and requirements. Nonetheless, such components are subject to these terms.

No TI components are authorized for use in FDA Class III (or similar life-critical medical equipment) unless authorized officers of the parties have executed a special agreement specifically governing such use.

Only those TI components which TI has specifically designated as military grade or "enhanced plastic" are designed and intended for use in military/aerospace applications or environments. Buyer acknowledges and agrees that any military or aerospace use of TI components which have **not** been so designated is solely at the Buyer's risk, and that Buyer is solely responsible for compliance with all legal and regulatory requirements in connection with such use.

TI has specifically designated certain components as meeting ISO/TS16949 requirements, mainly for automotive use. In any case of use of non-designated products, TI will not be responsible for any failure to meet ISO/TS16949.

Products

| | |
|------------------------------|--|
| Audio | www.ti.com/audio |
| Amplifiers | amplifier.ti.com |
| Data Converters | dataconverter.ti.com |
| DLP® Products | www.dlp.com |
| DSP | dsp.ti.com |
| Clocks and Timers | www.ti.com/clocks |
| Interface | interface.ti.com |
| Logic | logic.ti.com |
| Power Mgmt | power.ti.com |
| Microcontrollers | microcontroller.ti.com |
| RFID | www.ti-rfid.com |
| OMAP Applications Processors | www.ti.com/omap |
| Wireless Connectivity | www.ti.com/wirelessconnectivity |

Applications

| | |
|-------------------------------|--|
| Automotive and Transportation | www.ti.com/automotive |
| Communications and Telecom | www.ti.com/communications |
| Computers and Peripherals | www.ti.com/computers |
| Consumer Electronics | www.ti.com/consumer-apps |
| Energy and Lighting | www.ti.com/energy |
| Industrial | www.ti.com/industrial |
| Medical | www.ti.com/medical |
| Security | www.ti.com/security |
| Space, Avionics and Defense | www.ti.com/space-avionics-defense |
| Video and Imaging | www.ti.com/video |

TI E2E Community

e2e.ti.com