

# SN54LS257B, SN54LS258B, SN54S257, SN54S258 SN74LS257B, SN74LS258B, SN74S257, SN74S258 QUADRUPLE 2-LINE TO 1-LINE DATA SELECTORS/MULTIPLEXERS

SDLS148 – OCTOBER 1976 – REVISED MARCH 1988

- Three-State Outputs Interface Directly with System Bus
- 'LS257B and 'LS258B Offer Three Times the Sink-Current Capability of the Original 'LS257 and 'LS258
- Same Pin Assignments as SN54LS157, SN74LS157, SN54S157, SN74S157, and SN54LS158, SN74LS158, SN54S158, SN74S158
- Provides Bus Interface from Multiple Sources in High-Performance Systems

SN54LS257B, SN54S257,  
SN54LS258B, SN54S258 . . . J OR W PACKAGE  
SN74LS257B, SN74S257,  
SN74LS258B, SN74S258 . . . D OR N PACKAGE

(TOP VIEW)

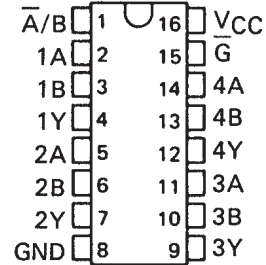

	AVERAGE PROPAGATION DELAY FROM DATA INPUT	TYPICAL POWER DISSIPATION†
'LS257B	9 ns	55 mW
'LS258B	9 ns	55 mW
'S257	4.8 ns	320 mW
'S258	4 ns	280 mW

† Off state (worst case)

### description

These devices are designed to multiplex signals from four-bit data sources to four-output data lines in bus-organized systems. The 3-state outputs will not load the data lines when the output control pin ( $\bar{G}$ ) is at a high-logic level.

Series 54LS and 54S are characterized for operation over the full military temperature range of  $-55^{\circ}\text{C}$  to  $125^{\circ}\text{C}$ ; Series 74LS and 74S are characterized for operation from  $0^{\circ}\text{C}$  to  $70^{\circ}\text{C}$ .

SN54LS257B, SN54S257,  
SN54LS258B, SN54S258 . . . FK PACKAGE

(TOP VIEW)

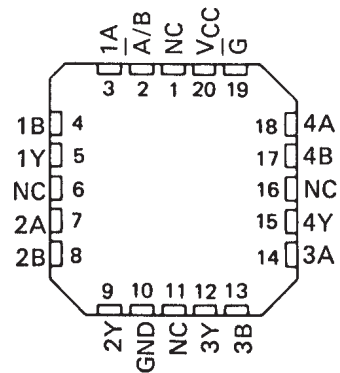

NC-No internal connection.

FUNCTION TABLE

OUTPUT CONTROL	INPUTS		OUTPUT Y		
	SELECT	A	B	'LS257B 'S257	'LS258B 'S258
H	X	X	X	Z	Z
L	L	L	X	L	H
L	L	H	X	H	L
L	H	X	L	L	H
L	H	X	H	H	L

H = high level, L = low level, X = irrelevant,  
Z = high impedance (off)

PRODUCTION DATA information is current as of publication date. Products conform to specifications per the terms of Texas Instruments standard warranty. Production processing does not necessarily include testing of all parameters.



SN54LS257B, SN54LS258B, SN54S257, SN54S258  
 SN74LS257B, SN74LS258B, SN74S257, SN74S258  
**QUADRUPLE 2-LINE TO 1-LINE DATA SELECTORS/MULTIPLEXERS**

SDLS148 - OCTOBER 1976 - REVISED MARCH 1988

logic diagrams (positive logic)

'LS257B, 'S257

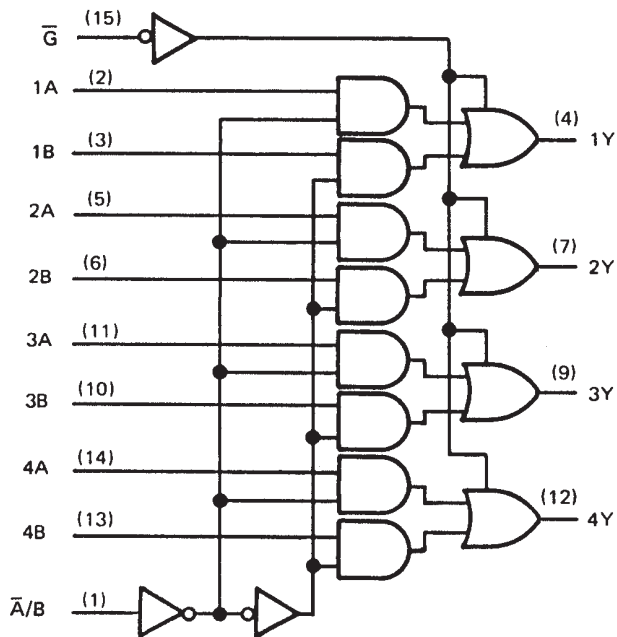

'LS258B, 'S258

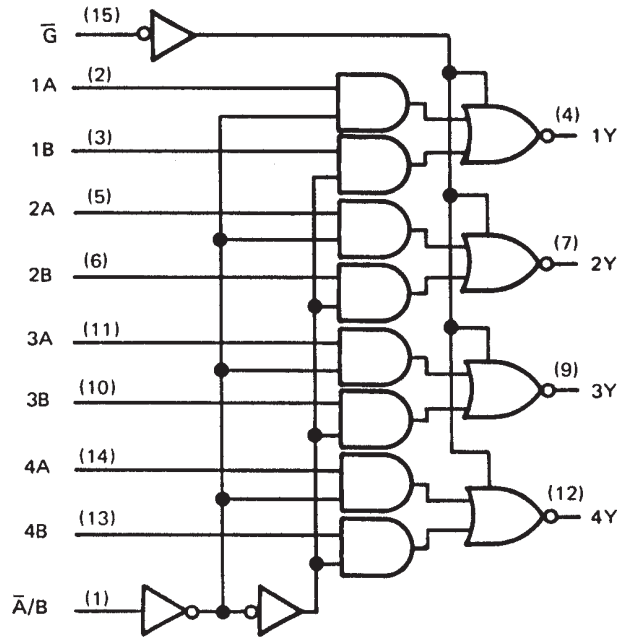

logic symbols†

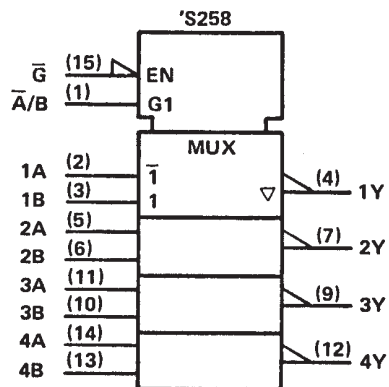
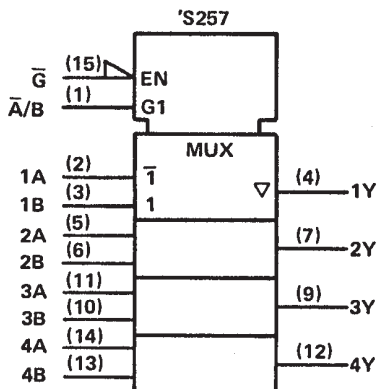
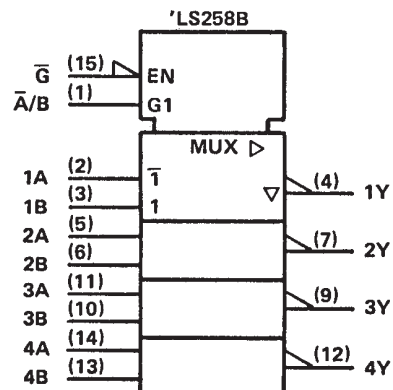
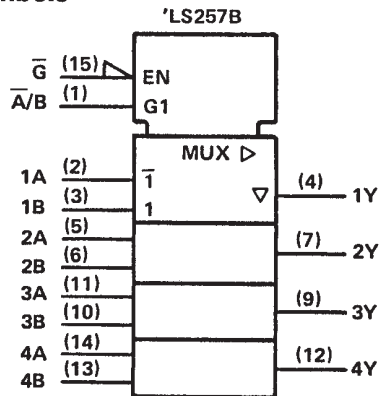

†These symbols are in accordance with ANSI/IEEE Std 91-1984 and IEC Publication 617-12. Pin numbers shown are for D, J, N, and W packages.



**SN54LS257B, SN54LS258B, SN54S257, SN54S258  
SN74LS257B, SN74LS258B, SN74S257, SN74S258  
QUADRUPLE 2-LINE TO 1-LINE DATA SELECTORS/MULTIPLEXERS**

SDLS148 – OCTOBER 1976 – REVISED MARCH 1988

**recommended operating conditions**

	SN54LS'			SN74LS'			UNIT
	MIN	NOM	MAX	MIN	NOM	MAX	
V <sub>CC</sub> Supply voltage	4.5	5	5.5	4.75	5	5.25	V
V <sub>IH</sub> High-level input voltage	2			2			V
V <sub>IL</sub> Low-level input voltage			0.7			0.8	V
I <sub>OH</sub> High-level output current			-1			-2.6	mA
I <sub>OL</sub> Low-level output current			12			24	mA
T <sub>A</sub> Operating free-air temperature	-55		125	0		70	°C

**electrical characteristics over recommended operating free-air temperature range (unless otherwise noted)**

PARAMETER	TEST CONDITIONS†	SN54LS'			SN74LS'			UNIT	
		MIN	TYP‡	MAX	MIN	TYP‡	MAX		
V <sub>IK</sub>	V <sub>CC</sub> = MIN, I <sub>I</sub> = -18 mA			-1.5			-1.5	V	
V <sub>OH</sub>	V <sub>CC</sub> = MIN, V <sub>IH</sub> = 2 V, V <sub>IL</sub> = MAX, I <sub>OH</sub> = MAX	2.4	3.4		2.4	3.1		V	
V <sub>OL</sub>	V <sub>CC</sub> = MIN, V <sub>IH</sub> = 2 V, V <sub>IL</sub> = MAX, I <sub>OL</sub> = 12 mA		0.25	0.4		0.25	0.4	V	
						0.35	0.5		
I <sub>OZH</sub>	V <sub>CC</sub> = MAX, V <sub>IH</sub> = 2 V, V <sub>O</sub> = 2.7 V			20			20	µA	
I <sub>OZL</sub>	V <sub>CC</sub> = MAX, V <sub>IH</sub> = 2 V, V <sub>O</sub> = 0.4 V			-20			-20	µA	
I <sub>I</sub>	V <sub>CC</sub> = MAX, V <sub>I</sub> = 7 V			0.1			0.1	mA	
I <sub>IH</sub>	V <sub>CC</sub> = MAX, V <sub>I</sub> = 2.7 V			20			20	µA	
I <sub>IL</sub>	V <sub>CC</sub> = MAX, V <sub>I</sub> = 0.4 V			-0.4			-0.4	mA	
I <sub>OS</sub> §	V <sub>CC</sub> = MAX,	-30		-130	-30		-130	mA	
I <sub>CC</sub>	All outputs high	V <sub>CC</sub> = MAX, See Note 2		'LS257B	8	12	8	12	mA
	All outputs low				12	18	12	18	
	All outputs off				13	19	13	19	
	All outputs high				6	9	6	9	
	All outputs low				10	15	10	15	
	All outputs off				11	16	11	16	

† For conditions shown as MIN or MAX, use the appropriate value specified under recommended operating conditions.

‡ All typical values are at V<sub>CC</sub> = 5 V, T<sub>A</sub> = 25°C.

§ Not more than one output should be shorted at a time and duration of the short-circuit should not exceed one second.

NOTE 2: I<sub>CC</sub> is measured with all outputs open and all possible inputs grounded while achieving the stated output conditions.

**switching characteristics, V<sub>CC</sub> = 5 V, T<sub>A</sub> = 25°C, R<sub>L</sub> = 667 Ω**

PARAMETER¶	FROM (INPUT)	TO (OUTPUT)	TEST CONDITIONS	'LS257B			'LS258B			UNIT
				MIN	TYP	MAX	MIN	TYP	MAX	
t <sub>PLH</sub>	Data	Any	C <sub>L</sub> = 45 pF, See Note 3	8	13		7	12	ns	
t <sub>PHL</sub>				10	15		11	17		
t <sub>PLH</sub>	Select	Any		16	21		14	21	ns	
t <sub>PHL</sub>				17	24		19	24		
t <sub>pZH</sub>	Output Control	Any		15	30		15	30	ns	
t <sub>pZL</sub>				19	30		20	30		
t <sub>PHZ</sub>	Output Control	Any	C <sub>L</sub> = 5 pF, See Note 3	18	30		18	30	ns	
t <sub>PLZ</sub>			16	25		16	25			

¶ t<sub>PLH</sub> = propagation delay time, low-to-high-level output

t<sub>PHL</sub> = propagation delay time, high-to-low-level output

t<sub>pZH</sub> = output enable time to high level

t<sub>pZL</sub> = output enable time to low level

t<sub>PHZ</sub> = output disable time from high level

t<sub>PLZ</sub> = output disable time from low level

NOTE 3: Load circuits and voltage waveforms are shown in Section 1.



# SN54LS257B, SN54LS258B, SN54S257, SN54S258 SN74LS257B, SN74LS258B, SN74S257, SN74S258 QUADRUPLE 2-LINE TO 1-LINE DATA SELECTORS/MULTIPLEXERS

SDLS148 - OCTOBER 1976 - REVISED MARCH 1988

## recommended operating conditions

	SN54S'			SN74S'			UNIT
	MIN	NOM	MAX	MIN	NOM	MAX	
Supply voltage, $V_{CC}$	4.5	5	5.5	4.75	5	5.25	V
High-level output current, $I_{OH}$			-2			-6.5	mA
Low-level output current, $I_{OL}$			20			20	mA
Operating free-air temperature, $T_A$	-55		125	0		70	°C

## electrical characteristics over recommended operating free-air temperature range (unless otherwise noted)

PARAMETER		TEST CONDITIONS†	'S257			'S258			UNIT
			MIN	TYP‡	MAX	MIN	TYP‡	MAX	
$V_{IH}$	High-level input voltage		2			2			V
$V_{IL}$	Low-level input voltage		0.8			0.8			V
$V_{IK}$	Input clamp voltage	$V_{CC} = \text{MIN}, I_I = -18 \text{ mA}$	-1.2			-1.2			V
$V_{OH}$	High-level output voltage	$V_{CC} = \text{MIN}, V_{IH} = 2 \text{ V}, V_{IL} = 0.8 \text{ V}, I_{OH} = -1 \text{ mA}$	SN74S'		2.7		2.7		V
		$V_{CC} = \text{MIN}, V_{IH} = 2 \text{ V}, V_{IL} = 0.8 \text{ V}, I_{OH} = \text{MAX}$	SN54S'		2.4 3.4		2.4 3.4		
			SN74S'		2.4 3.2		2.4 3.2		
$V_{OL}$	Low-level output voltage	$V_{CC} = \text{MIN}, V_{IH} = 2 \text{ V}, V_{IL} = 0.8 \text{ V}, I_{OL} = 20 \text{ mA}$	0.5			0.5			V
$I_{OZH}$	Off-state output current, high-level voltage applied	$V_{CC} = \text{MAX}, V_{IH} = 2 \text{ V}, V_O = 2.4 \text{ V}$	50			50			μA
$I_{OZL}$	Off-state output current, low-level voltage applied	$V_{CC} = \text{MAX}, V_{IH} = 2 \text{ V}, V_O = 0.5 \text{ V}$	-50			-50			μA
$I_I$	Input current at maximum input voltage	$V_{CC} = \text{MAX}, V_I = 5.5 \text{ V}$	1			1			mA
$I_{IH}$	High-level input current	S input	100			100			μA
		Any other	50			50			
$I_{IL}$	Low-level input current	S input	-4			-4			mA
		Any other	-2			-2			
$I_{OS}$	Short-circuit output current§	$V_{CC} = \text{MAX}$	-40 -100		-40 -100				mA
$I_{CC}$	Supply current	All outputs high	44 68		36 56				mA
		All outputs low	60 93		52 81				
		All outputs off	64 99		56 87				

† For conditions shown as MIN or MAX, use the appropriate value specified under recommended operating conditions.

‡ All typical values are at  $V_{CC} = 5 \text{ V}, T_A = 25^\circ\text{C}$ .

§ Not more than one output should be shorted at a time and duration of the short-circuit should not exceed one second.

NOTE 2:  $I_{CC}$  is measured with all outputs open and all possible inputs grounded while achieving the stated output conditions.

## switching characteristics, $V_{CC} = 5 \text{ V}, T_A = 25^\circ\text{C}, R_L = 280 \Omega$

PARAMETER¶	FROM (INPUT)	TO (OUTPUT)	TEST CONDITIONS	'S257			'S258			UNIT
				MIN	TYP	MAX	MIN	TYP	MAX	
$t_{PLH}$	Data	Any	$C_L = 15 \text{ pF},$ See Note 3	5 7.5		4 6		ns		
$t_{PHL}$				4.5 6.5		4 6				
$t_{PLH}$	Select	Any		8.5 15		8 12		ns		
$t_{PHL}$				8.5 15		7.5 12				
$t_{PZH}$	Output	Any		13 19.5		13 19.5		ns		
$t_{PZL}$	Control			14 21		14 21				
$t_{PHZ}$	Output	Any	5.5 8.5		5.5 8.5		ns			
$t_{PLZ}$	Control		9 14		9 14					

¶  $f_{\text{max}}$  = Maximum clock frequency

$t_{PLH}$  = propagation delay time, low-to-high-level output

$t_{PHL}$  = propagation delay time, high-to-low-level output

$t_{PZH}$  = output enable time to high level

$t_{PZL}$  = output enable time to low level

$t_{PHZ}$  = output disable time from high level

$t_{PLZ}$  = output disable time from low level

NOTE 3: Load circuits and voltage waveforms are shown in Section 1.



**PACKAGING INFORMATION**

Orderable Device	Status (1)	Package Type	Package Drawing	Pins	Package Qty	Eco Plan (2)	Lead/Ball Finish (6)	MSL Peak Temp (3)	Op Temp (°C)	Device Marking (4/5)	Samples
5962-7603701VEA	OBSOLETE	CDIP	J	16		TBD	Call TI	Call TI	-55 to 125	5962-7603701VE A SNV54LS257BJ	
5962-7603701VFA	OBSOLETE	CFP	W	16		TBD	Call TI	Call TI	-55 to 125	5962-7603701VF A SNV54LS257BW	
5962-7603701VFA	OBSOLETE	CFP	W	16		TBD	Call TI	Call TI	-55 to 125	5962-7603701VF A SNV54LS257BW	
7603701EA	ACTIVE	CDIP	J	16	1	TBD	A42	N / A for Pkg Type	-55 to 125	7603701EA SNJ54LS257BJ	<a href="#">Samples</a>
7603701EA	ACTIVE	CDIP	J	16	1	TBD	A42	N / A for Pkg Type	-55 to 125	7603701EA SNJ54LS257BJ	<a href="#">Samples</a>
7603701FA	ACTIVE	CFP	W	16	1	TBD	A42	N / A for Pkg Type	-55 to 125	7603701FA SNJ54LS257BW	<a href="#">Samples</a>
7603701FA	ACTIVE	CFP	W	16	1	TBD	A42	N / A for Pkg Type	-55 to 125	7603701FA SNJ54LS257BW	<a href="#">Samples</a>
76038012A	OBSOLETE	LCCC	FK	20		TBD	Call TI	Call TI	-55 to 125	76038012A SNJ54LS 258BFB	
76038012A	OBSOLETE	LCCC	FK	20		TBD	Call TI	Call TI	-55 to 125	76038012A SNJ54LS 258BFB	
7603801EA	ACTIVE	CDIP	J	16	1	TBD	A42	N / A for Pkg Type	-55 to 125	7603801EA SNJ54LS258BJ	<a href="#">Samples</a>
7603801EA	ACTIVE	CDIP	J	16	1	TBD	A42	N / A for Pkg Type	-55 to 125	7603801EA SNJ54LS258BJ	<a href="#">Samples</a>
7603801FA	OBSOLETE	CFP	W	16		TBD	Call TI	Call TI	-55 to 125	7603801FA SNJ54LS258BW	
7603801FA	OBSOLETE	CFP	W	16		TBD	Call TI	Call TI	-55 to 125	7603801FA SNJ54LS258BW	
8002301EA	ACTIVE	CDIP	J	16	1	TBD	A42	N / A for Pkg Type	-55 to 125	8002301EA SNJ54S258J	<a href="#">Samples</a>
8002301EA	ACTIVE	CDIP	J	16	1	TBD	A42	N / A for Pkg Type	-55 to 125	8002301EA SNJ54S258J	<a href="#">Samples</a>

Orderable Device	Status (1)	Package Type	Package Drawing	Pins	Package Qty	Eco Plan (2)	Lead/Ball Finish (6)	MSL Peak Temp (3)	Op Temp (°C)	Device Marking (4/5)	Samples
8002301FA	ACTIVE	CFP	W	16	1	TBD	A42	N / A for Pkg Type	-55 to 125	8002301FA SNJ54S258W	<a href="#">Samples</a>
8002301FA	ACTIVE	CFP	W	16	1	TBD	A42	N / A for Pkg Type	-55 to 125	8002301FA SNJ54S258W	<a href="#">Samples</a>
JM38510/07906BEA	ACTIVE	CDIP	J	16	1	TBD	A42	N / A for Pkg Type	-55 to 125	JM38510/ 07906BEA	<a href="#">Samples</a>
JM38510/07906BEA	ACTIVE	CDIP	J	16	1	TBD	A42	N / A for Pkg Type	-55 to 125	JM38510/ 07906BEA	<a href="#">Samples</a>
JM38510/07906BFA	ACTIVE	CFP	W	16	1	TBD	A42	N / A for Pkg Type	-55 to 125	JM38510/ 07906BFA	<a href="#">Samples</a>
JM38510/07906BFA	ACTIVE	CFP	W	16	1	TBD	A42	N / A for Pkg Type	-55 to 125	JM38510/ 07906BFA	<a href="#">Samples</a>
JM38510/30906B2A	ACTIVE	LCCC	FK	20	1	TBD	POST-PLATE	N / A for Pkg Type	-55 to 125	JM38510/ 30906B2A	<a href="#">Samples</a>
JM38510/30906B2A	ACTIVE	LCCC	FK	20	1	TBD	POST-PLATE	N / A for Pkg Type	-55 to 125	JM38510/ 30906B2A	<a href="#">Samples</a>
JM38510/30906BEA	ACTIVE	CDIP	J	16	1	TBD	A42	N / A for Pkg Type	-55 to 125	JM38510/ 30906BEA	<a href="#">Samples</a>
JM38510/30906BEA	ACTIVE	CDIP	J	16	1	TBD	A42	N / A for Pkg Type	-55 to 125	JM38510/ 30906BEA	<a href="#">Samples</a>
JM38510/30906BFA	ACTIVE	CFP	W	16	1	TBD	A42	N / A for Pkg Type	-55 to 125	JM38510/ 30906BFA	<a href="#">Samples</a>
JM38510/30906BFA	ACTIVE	CFP	W	16	1	TBD	A42	N / A for Pkg Type	-55 to 125	JM38510/ 30906BFA	<a href="#">Samples</a>
M38510/07906BEA	ACTIVE	CDIP	J	16	1	TBD	A42	N / A for Pkg Type	-55 to 125	JM38510/ 07906BEA	<a href="#">Samples</a>
M38510/07906BEA	ACTIVE	CDIP	J	16	1	TBD	A42	N / A for Pkg Type	-55 to 125	JM38510/ 07906BEA	<a href="#">Samples</a>
M38510/07906BFA	ACTIVE	CFP	W	16	1	TBD	A42	N / A for Pkg Type	-55 to 125	JM38510/ 07906BFA	<a href="#">Samples</a>
M38510/07906BFA	ACTIVE	CFP	W	16	1	TBD	A42	N / A for Pkg Type	-55 to 125	JM38510/ 07906BFA	<a href="#">Samples</a>
M38510/30906B2A	ACTIVE	LCCC	FK	20	1	TBD	POST-PLATE	N / A for Pkg Type	-55 to 125	JM38510/ 30906B2A	<a href="#">Samples</a>
M38510/30906B2A	ACTIVE	LCCC	FK	20	1	TBD	POST-PLATE	N / A for Pkg Type	-55 to 125	JM38510/ 30906B2A	<a href="#">Samples</a>

Orderable Device	Status (1)	Package Type	Package Drawing	Pins	Package Qty	Eco Plan (2)	Lead/Ball Finish (6)	MSL Peak Temp (3)	Op Temp (°C)	Device Marking (4/5)	Samples
M38510/30906BEA	ACTIVE	CDIP	J	16	1	TBD	A42	N / A for Pkg Type	-55 to 125	JM38510/ 30906BEA	<a href="#">Samples</a>
M38510/30906BEA	ACTIVE	CDIP	J	16	1	TBD	A42	N / A for Pkg Type	-55 to 125	JM38510/ 30906BEA	<a href="#">Samples</a>
M38510/30906BFA	ACTIVE	CFP	W	16	1	TBD	A42	N / A for Pkg Type	-55 to 125	JM38510/ 30906BFA	<a href="#">Samples</a>
M38510/30906BFA	ACTIVE	CFP	W	16	1	TBD	A42	N / A for Pkg Type	-55 to 125	JM38510/ 30906BFA	<a href="#">Samples</a>
SN54LS257BJ	ACTIVE	CDIP	J	16	1	TBD	A42	N / A for Pkg Type	-55 to 125	SN54LS257BJ	<a href="#">Samples</a>
SN54LS257BJ	ACTIVE	CDIP	J	16	1	TBD	A42	N / A for Pkg Type	-55 to 125	SN54LS257BJ	<a href="#">Samples</a>
SN54LS258BJ	ACTIVE	CDIP	J	16	1	TBD	A42	N / A for Pkg Type	-55 to 125	SN54LS258BJ	<a href="#">Samples</a>
SN54LS258BJ	ACTIVE	CDIP	J	16	1	TBD	A42	N / A for Pkg Type	-55 to 125	SN54LS258BJ	<a href="#">Samples</a>
SN54S257J	ACTIVE	CDIP	J	16	1	TBD	A42	N / A for Pkg Type	-55 to 125	SN54S257J	<a href="#">Samples</a>
SN54S257J	ACTIVE	CDIP	J	16	1	TBD	A42	N / A for Pkg Type	-55 to 125	SN54S257J	<a href="#">Samples</a>
SN54S258J	OBSOLETE	CDIP	J	16		TBD	Call TI	Call TI	-55 to 125	SN54S258J	
SN54S258J	OBSOLETE	CDIP	J	16		TBD	Call TI	Call TI	-55 to 125	SN54S258J	
SN74LS257BD	ACTIVE	SOIC	D	16	40	Green (RoHS & no Sb/Br)	CU NIPDAU	Level-1-260C-UNLIM	0 to 70	LS257B	<a href="#">Samples</a>
SN74LS257BD	ACTIVE	SOIC	D	16	40	Green (RoHS & no Sb/Br)	CU NIPDAU	Level-1-260C-UNLIM	0 to 70	LS257B	<a href="#">Samples</a>
SN74LS257BDE4	ACTIVE	SOIC	D	16	40	Green (RoHS & no Sb/Br)	CU NIPDAU	Level-1-260C-UNLIM	0 to 70	LS257B	<a href="#">Samples</a>
SN74LS257BDE4	ACTIVE	SOIC	D	16	40	Green (RoHS & no Sb/Br)	CU NIPDAU	Level-1-260C-UNLIM	0 to 70	LS257B	<a href="#">Samples</a>
SN74LS257BDG4	ACTIVE	SOIC	D	16	40	Green (RoHS & no Sb/Br)	CU NIPDAU	Level-1-260C-UNLIM	0 to 70	LS257B	<a href="#">Samples</a>
SN74LS257BDG4	ACTIVE	SOIC	D	16	40	Green (RoHS & no Sb/Br)	CU NIPDAU	Level-1-260C-UNLIM	0 to 70	LS257B	<a href="#">Samples</a>
SN74LS257BDR	ACTIVE	SOIC	D	16	2500	Green (RoHS & no Sb/Br)	CU NIPDAU	Level-1-260C-UNLIM	0 to 70	LS257B	<a href="#">Samples</a>
SN74LS257BDR	ACTIVE	SOIC	D	16	2500	Green (RoHS & no Sb/Br)	CU NIPDAU	Level-1-260C-UNLIM	0 to 70	LS257B	<a href="#">Samples</a>

Orderable Device	Status (1)	Package Type	Package Drawing	Pins	Package Qty	Eco Plan (2)	Lead/Ball Finish (6)	MSL Peak Temp (3)	Op Temp (°C)	Device Marking (4/5)	Samples
SN74LS257BN	ACTIVE	PDIP	N	16	25	Pb-Free (RoHS)	CU NIPDAU	N / A for Pkg Type	0 to 70	SN74LS257BN	<a href="#">Samples</a>
SN74LS257BN	ACTIVE	PDIP	N	16	25	Pb-Free (RoHS)	CU NIPDAU	N / A for Pkg Type	0 to 70	SN74LS257BN	<a href="#">Samples</a>
SN74LS257BN3	OBSOLETE	PDIP	N	16		TBD	Call TI	Call TI	0 to 70		
SN74LS257BN3	OBSOLETE	PDIP	N	16		TBD	Call TI	Call TI	0 to 70		
SN74LS257BNE4	ACTIVE	PDIP	N	16	25	Pb-Free (RoHS)	CU NIPDAU	N / A for Pkg Type	0 to 70	SN74LS257BN	<a href="#">Samples</a>
SN74LS257BNE4	ACTIVE	PDIP	N	16	25	Pb-Free (RoHS)	CU NIPDAU	N / A for Pkg Type	0 to 70	SN74LS257BN	<a href="#">Samples</a>
SN74LS257BNSR	ACTIVE	SO	NS	16	2000	Green (RoHS & no Sb/Br)	CU NIPDAU	Level-1-260C-UNLIM	0 to 70	74LS257B	<a href="#">Samples</a>
SN74LS257BNSR	ACTIVE	SO	NS	16	2000	Green (RoHS & no Sb/Br)	CU NIPDAU	Level-1-260C-UNLIM	0 to 70	74LS257B	<a href="#">Samples</a>
SN74LS258BD	ACTIVE	SOIC	D	16	40	Green (RoHS & no Sb/Br)	CU NIPDAU	Level-1-260C-UNLIM	0 to 70	LS258B	<a href="#">Samples</a>
SN74LS258BD	ACTIVE	SOIC	D	16	40	Green (RoHS & no Sb/Br)	CU NIPDAU	Level-1-260C-UNLIM	0 to 70	LS258B	<a href="#">Samples</a>
SN74LS258BDR	ACTIVE	SOIC	D	16	2500	Green (RoHS & no Sb/Br)	CU NIPDAU	Level-1-260C-UNLIM	0 to 70	LS258B	<a href="#">Samples</a>
SN74LS258BDR	ACTIVE	SOIC	D	16	2500	Green (RoHS & no Sb/Br)	CU NIPDAU	Level-1-260C-UNLIM	0 to 70	LS258B	<a href="#">Samples</a>
SN74LS258BN	ACTIVE	PDIP	N	16	25	Pb-Free (RoHS)	CU NIPDAU	N / A for Pkg Type	0 to 70	SN74LS258BN	<a href="#">Samples</a>
SN74LS258BN	ACTIVE	PDIP	N	16	25	Pb-Free (RoHS)	CU NIPDAU	N / A for Pkg Type	0 to 70	SN74LS258BN	<a href="#">Samples</a>
SN74LS258BN3	OBSOLETE	PDIP	N	16		TBD	Call TI	Call TI	0 to 70		
SN74LS258BN3	OBSOLETE	PDIP	N	16		TBD	Call TI	Call TI	0 to 70		
SN74S257N	NRND	PDIP	N	16	25	Pb-Free (RoHS)	CU NIPDAU	N / A for Pkg Type	0 to 70	SN74S257N	
SN74S257N	NRND	PDIP	N	16	25	Pb-Free (RoHS)	CU NIPDAU	N / A for Pkg Type	0 to 70	SN74S257N	
SN74S257N3	OBSOLETE	PDIP	N	16		TBD	Call TI	Call TI	0 to 70		
SN74S257N3	OBSOLETE	PDIP	N	16		TBD	Call TI	Call TI	0 to 70		
SN74S258DR	OBSOLETE	SOIC	D	16		TBD	Call TI	Call TI	0 to 70		

Orderable Device	Status (1)	Package Type	Package Drawing	Pins	Package Qty	Eco Plan (2)	Lead/Ball Finish (6)	MSL Peak Temp (3)	Op Temp (°C)	Device Marking (4/5)	Samples
SN74S258DR	OBSOLETE	SOIC	D	16		TBD	Call TI	Call TI	0 to 70		
SN74S258N	OBSOLETE	PDIP	N	16		TBD	Call TI	Call TI	0 to 70		
SN74S258N	OBSOLETE	PDIP	N	16		TBD	Call TI	Call TI	0 to 70		
SN74S258N3	OBSOLETE	PDIP	N	16		TBD	Call TI	Call TI	0 to 70		
SN74S258N3	OBSOLETE	PDIP	N	16		TBD	Call TI	Call TI	0 to 70		
SNJ54LS257BFK	ACTIVE	LCCC	FK	20	1	TBD	POST-PLATE	N / A for Pkg Type	-55 to 125	SNJ54LS 257BFK	<a href="#">Samples</a>
SNJ54LS257BFK	ACTIVE	LCCC	FK	20	1	TBD	POST-PLATE	N / A for Pkg Type	-55 to 125	SNJ54LS 257BFK	<a href="#">Samples</a>
SNJ54LS257BJ	ACTIVE	CDIP	J	16	1	TBD	A42	N / A for Pkg Type	-55 to 125	7603701EA SNJ54LS257BJ	<a href="#">Samples</a>
SNJ54LS257BJ	ACTIVE	CDIP	J	16	1	TBD	A42	N / A for Pkg Type	-55 to 125	7603701EA SNJ54LS257BJ	<a href="#">Samples</a>
SNJ54LS257BW	ACTIVE	CFP	W	16	1	TBD	A42	N / A for Pkg Type	-55 to 125	7603701FA SNJ54LS257BW	<a href="#">Samples</a>
SNJ54LS257BW	ACTIVE	CFP	W	16	1	TBD	A42	N / A for Pkg Type	-55 to 125	7603701FA SNJ54LS257BW	<a href="#">Samples</a>
SNJ54LS258BFK	OBSOLETE	LCCC	FK	20		TBD	Call TI	Call TI	-55 to 125	76038012A SNJ54LS 258BFK	
SNJ54LS258BFK	OBSOLETE	LCCC	FK	20		TBD	Call TI	Call TI	-55 to 125	76038012A SNJ54LS 258BFK	
SNJ54LS258BJ	ACTIVE	CDIP	J	16	1	TBD	A42	N / A for Pkg Type	-55 to 125	7603801EA SNJ54LS258BJ	<a href="#">Samples</a>
SNJ54LS258BJ	ACTIVE	CDIP	J	16	1	TBD	A42	N / A for Pkg Type	-55 to 125	7603801EA SNJ54LS258BJ	<a href="#">Samples</a>
SNJ54LS258BW	OBSOLETE	CFP	W	16		TBD	Call TI	Call TI	-55 to 125	7603801FA SNJ54LS258BW	
SNJ54LS258BW	OBSOLETE	CFP	W	16		TBD	Call TI	Call TI	-55 to 125	7603801FA SNJ54LS258BW	
SNJ54S257FK	OBSOLETE	LCCC	FK	20		TBD	Call TI	Call TI	-55 to 125	SNJ54S 257FK	
SNJ54S257FK	OBSOLETE	LCCC	FK	20		TBD	Call TI	Call TI	-55 to 125	SNJ54S 257FK	

Orderable Device	Status (1)	Package Type	Package Drawing	Pins	Package Qty	Eco Plan (2)	Lead/Ball Finish (6)	MSL Peak Temp (3)	Op Temp (°C)	Device Marking (4/5)	Samples
SNJ54S257J	ACTIVE	CDIP	J	16	1	TBD	A42	N / A for Pkg Type	-55 to 125	SNJ54S257J	<a href="#">Samples</a>
SNJ54S257J	ACTIVE	CDIP	J	16	1	TBD	A42	N / A for Pkg Type	-55 to 125	SNJ54S257J	<a href="#">Samples</a>
SNJ54S257W	ACTIVE	CFP	W	16	1	TBD	A42	N / A for Pkg Type	-55 to 125	SNJ54S257W	<a href="#">Samples</a>
SNJ54S257W	ACTIVE	CFP	W	16	1	TBD	A42	N / A for Pkg Type	-55 to 125	SNJ54S257W	<a href="#">Samples</a>
SNJ54S258FK	OBSOLETE	LCCC	FK	20		TBD	Call TI	Call TI	-55 to 125	SNJ54S 258FK	
SNJ54S258FK	OBSOLETE	LCCC	FK	20		TBD	Call TI	Call TI	-55 to 125	SNJ54S 258FK	
SNJ54S258J	ACTIVE	CDIP	J	16	1	TBD	A42	N / A for Pkg Type	-55 to 125	8002301EA SNJ54S258J	<a href="#">Samples</a>
SNJ54S258J	ACTIVE	CDIP	J	16	1	TBD	A42	N / A for Pkg Type	-55 to 125	8002301EA SNJ54S258J	<a href="#">Samples</a>
SNJ54S258W	ACTIVE	CFP	W	16	1	TBD	A42	N / A for Pkg Type	-55 to 125	8002301FA SNJ54S258W	<a href="#">Samples</a>
SNJ54S258W	ACTIVE	CFP	W	16	1	TBD	A42	N / A for Pkg Type	-55 to 125	8002301FA SNJ54S258W	<a href="#">Samples</a>

(1) The marketing status values are defined as follows:

**ACTIVE:** Product device recommended for new designs.

**LIFEBUY:** TI has announced that the device will be discontinued, and a lifetime-buy period is in effect.

**NRND:** Not recommended for new designs. Device is in production to support existing customers, but TI does not recommend using this part in a new design.

**PREVIEW:** Device has been announced but is not in production. Samples may or may not be available.

**OBSOLETE:** TI has discontinued the production of the device.

(2) Eco Plan - The planned eco-friendly classification: Pb-Free (RoHS), Pb-Free (RoHS Exempt), or Green (RoHS & no Sb/Br) - please check <http://www.ti.com/productcontent> for the latest availability information and additional product content details.

**TBD:** The Pb-Free/Green conversion plan has not been defined.

**Pb-Free (RoHS):** TI's terms "Lead-Free" or "Pb-Free" mean semiconductor products that are compatible with the current RoHS requirements for all 6 substances, including the requirement that lead not exceed 0.1% by weight in homogeneous materials. Where designed to be soldered at high temperatures, TI Pb-Free products are suitable for use in specified lead-free processes.

**Pb-Free (RoHS Exempt):** This component has a RoHS exemption for either 1) lead-based flip-chip solder bumps used between the die and package, or 2) lead-based die adhesive used between the die and leadframe. The component is otherwise considered Pb-Free (RoHS compatible) as defined above.

**Green (RoHS & no Sb/Br):** TI defines "Green" to mean Pb-Free (RoHS compatible), and free of Bromine (Br) and Antimony (Sb) based flame retardants (Br or Sb do not exceed 0.1% by weight in homogeneous material)

(3) MSL, Peak Temp. - The Moisture Sensitivity Level rating according to the JEDEC industry standard classifications, and peak solder temperature.

(4) There may be additional marking, which relates to the logo, the lot trace code information, or the environmental category on the device.

(5) Multiple Device Markings will be inside parentheses. Only one Device Marking contained in parentheses and separated by a "~" will appear on a device. If a line is indented then it is a continuation of the previous line and the two combined represent the entire Device Marking for that device.

(6) Lead/Ball Finish - Orderable Devices may have multiple material finish options. Finish options are separated by a vertical ruled line. Lead/Ball Finish values may wrap to two lines if the finish value exceeds the maximum column width.

**Important Information and Disclaimer:**The information provided on this page represents TI's knowledge and belief as of the date that it is provided. TI bases its knowledge and belief on information provided by third parties, and makes no representation or warranty as to the accuracy of such information. Efforts are underway to better integrate information from third parties. TI has taken and continues to take reasonable steps to provide representative and accurate information but may not have conducted destructive testing or chemical analysis on incoming materials and chemicals. TI and TI suppliers consider certain information to be proprietary, and thus CAS numbers and other limited information may not be available for release.

In no event shall TI's liability arising out of such information exceed the total purchase price of the TI part(s) at issue in this document sold by TI to Customer on an annual basis.

**OTHER QUALIFIED VERSIONS OF SN54LS257B, SN54LS257B-SP, SN54LS258B, SN54S257, SN54S258, SN74LS257B, SN74LS258B, SN74S257, SN74S258 :**

● Catalog: [SN74LS257B](#), [SN54LS257B](#), [SN74LS258B](#), [SN74S257](#), [SN74S258](#)

● Military: [SN54LS257B](#), [SN54LS258B](#), [SN54S257](#), [SN54S258](#)

● Space: [SN54LS257B-SP](#)

NOTE: Qualified Version Definitions:

- Catalog - TI's standard catalog product
- Military - QML certified for Military and Defense Applications
- Space - Radiation tolerant, ceramic packaging and qualified for use in Space-based application

**TAPE AND REEL INFORMATION**
**REEL DIMENSIONS**

**TAPE DIMENSIONS**

A0	Dimension designed to accommodate the component width
B0	Dimension designed to accommodate the component length
K0	Dimension designed to accommodate the component thickness
W	Overall width of the carrier tape
P1	Pitch between successive cavity centers

**TAPE AND REEL INFORMATION**

\*All dimensions are nominal

Device	Package Type	Package Drawing	Pins	SPQ	Reel Diameter (mm)	Reel Width W1 (mm)	A0 (mm)	B0 (mm)	K0 (mm)	P1 (mm)	W (mm)	Pin1 Quadrant
SN74LS257BDR	SOIC	D	16	2500	330.0	16.4	6.5	10.3	2.1	8.0	16.0	Q1
SN74LS257BNSR	SO	NS	16	2000	330.0	16.4	8.2	10.5	2.5	12.0	16.0	Q1
SN74LS258BDR	SOIC	D	16	2500	330.0	16.4	6.5	10.3	2.1	8.0	16.0	Q1

**TAPE AND REEL BOX DIMENSIONS**

\*All dimensions are nominal

Device	Package Type	Package Drawing	Pins	SPQ	Length (mm)	Width (mm)	Height (mm)
SN74LS257BDR	SOIC	D	16	2500	333.2	345.9	28.6
SN74LS257BNSR	SO	NS	16	2000	367.0	367.0	38.0
SN74LS258BDR	SOIC	D	16	2500	333.2	345.9	28.6

J (R-GDIP-T\*\*)

14 LEADS SHOWN

CERAMIC DUAL IN-LINE PACKAGE



DIM \ PINS **	14	16	18	20
A	0.300 (7,62) BSC	0.300 (7,62) BSC	0.300 (7,62) BSC	0.300 (7,62) BSC
B MAX	0.785 (19,94)	.840 (21,34)	0.960 (24,38)	1.060 (26,92)
B MIN	—	—	—	—
C MAX	0.300 (7,62)	0.300 (7,62)	0.310 (7,87)	0.300 (7,62)
C MIN	0.245 (6,22)	0.245 (6,22)	0.220 (5,59)	0.245 (6,22)



4040083/F 03/03

- NOTES:
- All linear dimensions are in inches (millimeters).
  - This drawing is subject to change without notice.
  - This package is hermetically sealed with a ceramic lid using glass frit.
  - Index point is provided on cap for terminal identification only on press ceramic glass frit seal only.
  - Falls within MIL STD 1835 GDIP1-T14, GDIP1-T16, GDIP1-T18 and GDIP1-T20.

W (R-GDFP-F16)

CERAMIC DUAL FLATPACK

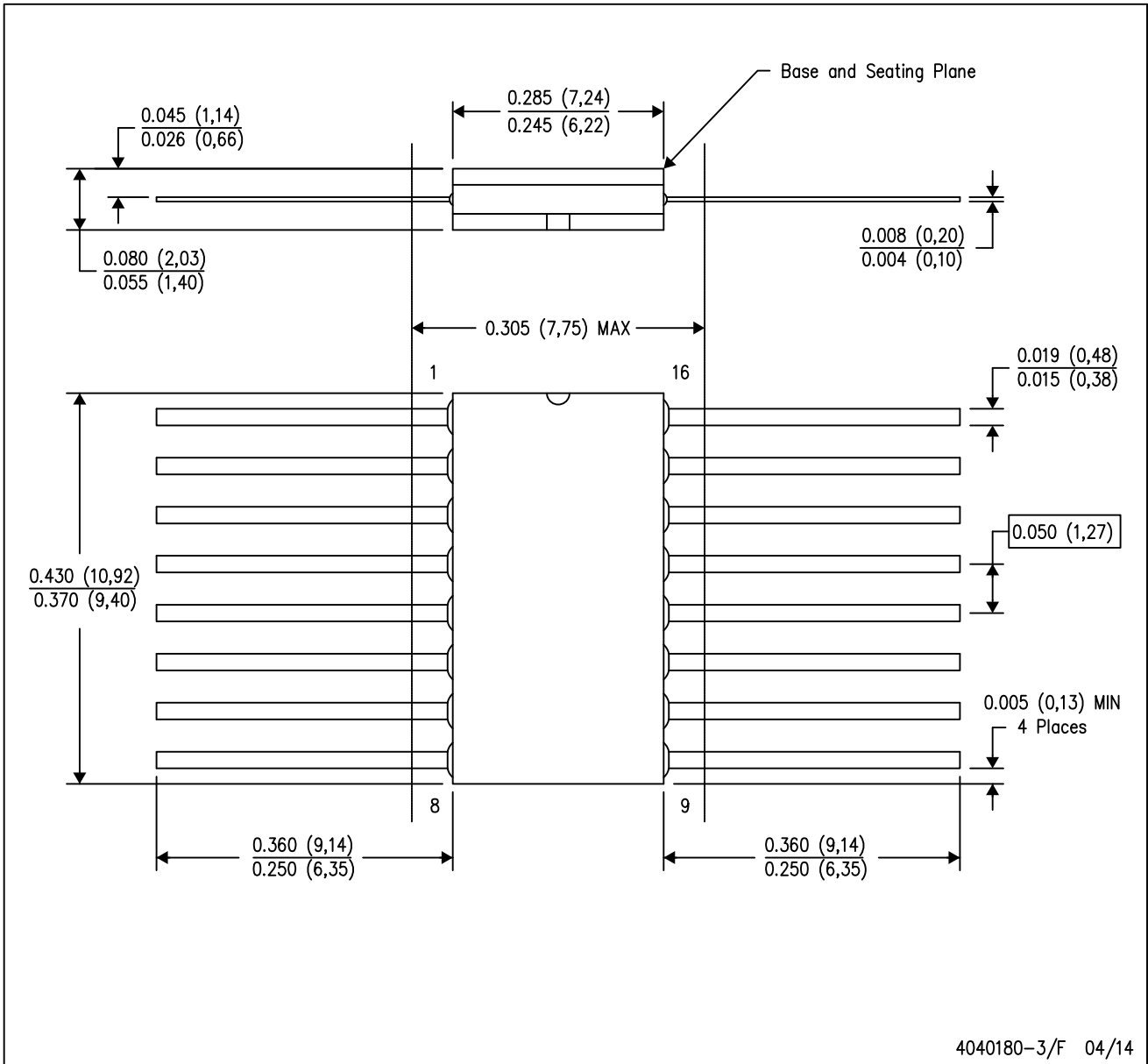

- NOTES:
- A. All linear dimensions are in inches (millimeters).
  - B. This drawing is subject to change without notice.
  - C. This package can be hermetically sealed with a ceramic lid using glass frit.
  - D. Index point is provided on cap for terminal identification only.
  - E. Falls within MIL STD 1835 GDFP2-F16

FK (S-CQCC-N\*\*)

LEADLESS CERAMIC CHIP CARRIER

28 TERMINAL SHOWN



NO. OF TERMINALS **	A		B	
	MIN	MAX	MIN	MAX
20	0.342 (8,69)	0.358 (9,09)	0.307 (7,80)	0.358 (9,09)
28	0.442 (11,23)	0.458 (11,63)	0.406 (10,31)	0.458 (11,63)
44	0.640 (16,26)	0.660 (16,76)	0.495 (12,58)	0.560 (14,22)
52	0.740 (18,78)	0.761 (19,32)	0.495 (12,58)	0.560 (14,22)
68	0.938 (23,83)	0.962 (24,43)	0.850 (21,6)	0.858 (21,8)
84	1.141 (28,99)	1.165 (29,59)	1.047 (26,6)	1.063 (27,0)

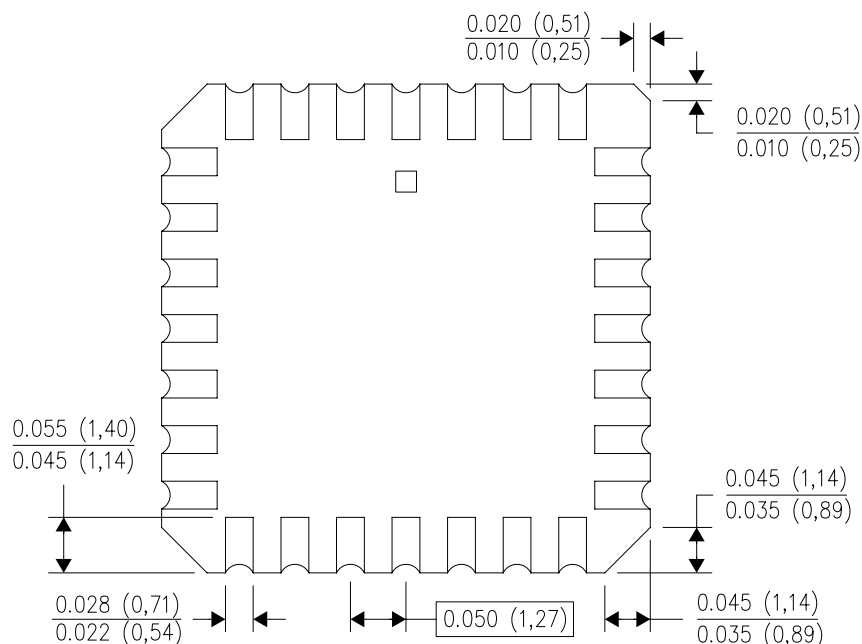

4040140/D 01/11

- NOTES:
- All linear dimensions are in inches (millimeters).
  - This drawing is subject to change without notice.
  - This package can be hermetically sealed with a metal lid.
  - Falls within JEDEC MS-004

N (R-PDIP-T\*\*)

PLASTIC DUAL-IN-LINE PACKAGE

16 PINS SHOWN



- NOTES:
- A. All linear dimensions are in inches (millimeters).
  - B. This drawing is subject to change without notice.
  - C Falls within JEDEC MS-001, except 18 and 20 pin minimum body length (Dim A).
  - D The 20 pin end lead shoulder width is a vendor option, either half or full width.

4040049/E 12/2002

D (R-PDSO-G16)

PLASTIC SMALL OUTLINE



4040047-6/M 06/11

- NOTES:
- A. All linear dimensions are in inches (millimeters).
  - B. This drawing is subject to change without notice.
  -  Body length does not include mold flash, protrusions, or gate burrs. Mold flash, protrusions, or gate burrs shall not exceed 0.006 (0,15) each side.
  -  Body width does not include interlead flash. Interlead flash shall not exceed 0.017 (0,43) each side.
  - E. Reference JEDEC MS-012 variation AC.

D (R-PDSO-G16)

PLASTIC SMALL OUTLINE

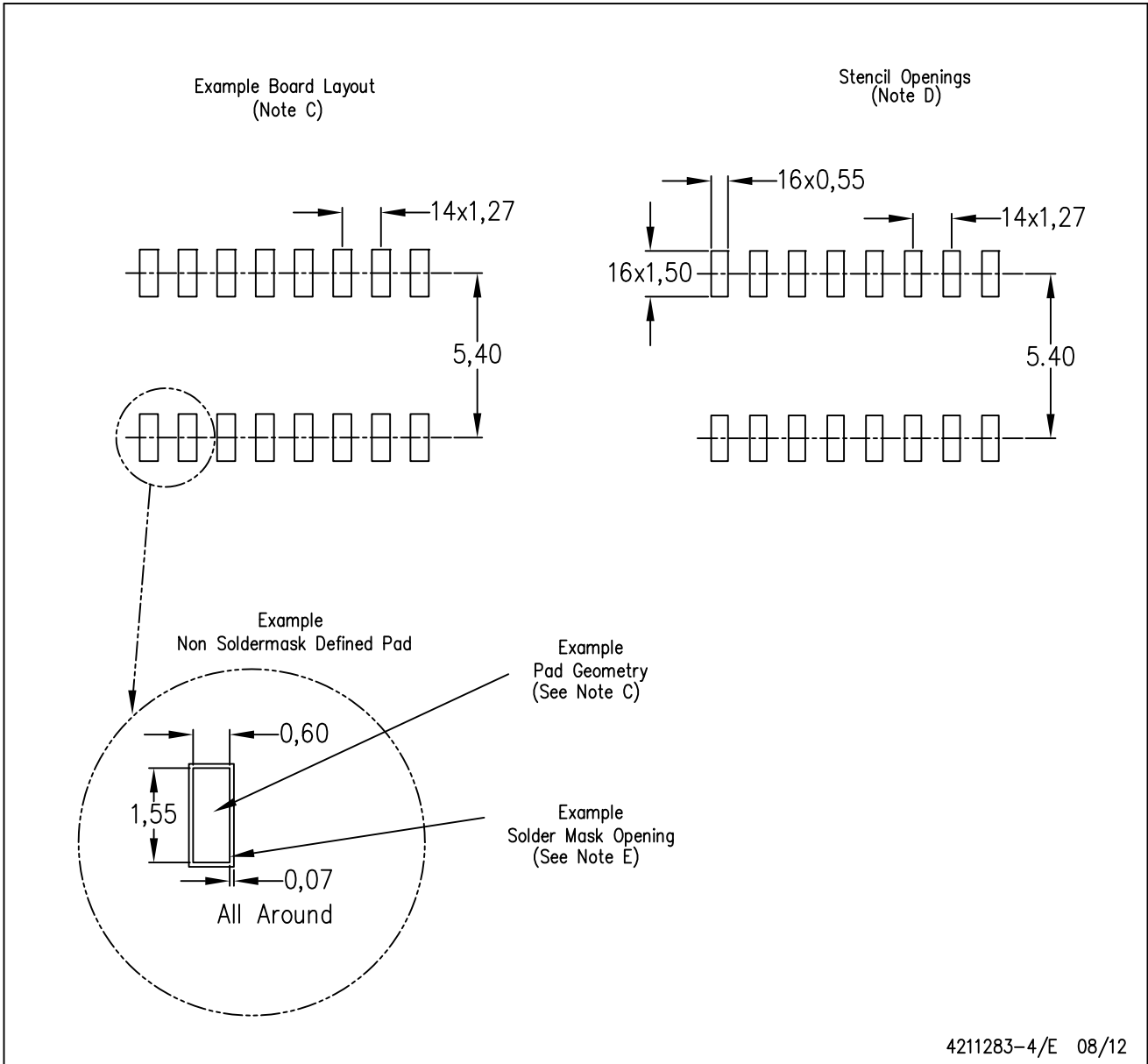

- NOTES:
- A. All linear dimensions are in millimeters.
  - B. This drawing is subject to change without notice.
  - C. Publication IPC-7351 is recommended for alternate designs.
  - D. Laser cutting apertures with trapezoidal walls and also rounding corners will offer better paste release. Customers should contact their board assembly site for stencil design recommendations. Refer to IPC-7525 for other stencil recommendations.
  - E. Customers should contact their board fabrication site for solder mask tolerances between and around signal pads.

## MECHANICAL DATA

NS (R-PDSO-G\*\*)

PLASTIC SMALL-OUTLINE PACKAGE

14-PINS SHOWN



- NOTES:
- A. All linear dimensions are in millimeters.
  - B. This drawing is subject to change without notice.
  - C. Body dimensions do not include mold flash or protrusion, not to exceed 0,15.

## IMPORTANT NOTICE

Texas Instruments Incorporated and its subsidiaries (TI) reserve the right to make corrections, enhancements, improvements and other changes to its semiconductor products and services per JESD46, latest issue, and to discontinue any product or service per JESD48, latest issue. Buyers should obtain the latest relevant information before placing orders and should verify that such information is current and complete. All semiconductor products (also referred to herein as "components") are sold subject to TI's terms and conditions of sale supplied at the time of order acknowledgment.

TI warrants performance of its components to the specifications applicable at the time of sale, in accordance with the warranty in TI's terms and conditions of sale of semiconductor products. Testing and other quality control techniques are used to the extent TI deems necessary to support this warranty. Except where mandated by applicable law, testing of all parameters of each component is not necessarily performed.

TI assumes no liability for applications assistance or the design of Buyers' products. Buyers are responsible for their products and applications using TI components. To minimize the risks associated with Buyers' products and applications, Buyers should provide adequate design and operating safeguards.

TI does not warrant or represent that any license, either express or implied, is granted under any patent right, copyright, mask work right, or other intellectual property right relating to any combination, machine, or process in which TI components or services are used. Information published by TI regarding third-party products or services does not constitute a license to use such products or services or a warranty or endorsement thereof. Use of such information may require a license from a third party under the patents or other intellectual property of the third party, or a license from TI under the patents or other intellectual property of TI.

Reproduction of significant portions of TI information in TI data books or data sheets is permissible only if reproduction is without alteration and is accompanied by all associated warranties, conditions, limitations, and notices. TI is not responsible or liable for such altered documentation. Information of third parties may be subject to additional restrictions.

Resale of TI components or services with statements different from or beyond the parameters stated by TI for that component or service voids all express and any implied warranties for the associated TI component or service and is an unfair and deceptive business practice. TI is not responsible or liable for any such statements.

Buyer acknowledges and agrees that it is solely responsible for compliance with all legal, regulatory and safety-related requirements concerning its products, and any use of TI components in its applications, notwithstanding any applications-related information or support that may be provided by TI. Buyer represents and agrees that it has all the necessary expertise to create and implement safeguards which anticipate dangerous consequences of failures, monitor failures and their consequences, lessen the likelihood of failures that might cause harm and take appropriate remedial actions. Buyer will fully indemnify TI and its representatives against any damages arising out of the use of any TI components in safety-critical applications.

In some cases, TI components may be promoted specifically to facilitate safety-related applications. With such components, TI's goal is to help enable customers to design and create their own end-product solutions that meet applicable functional safety standards and requirements. Nonetheless, such components are subject to these terms.

No TI components are authorized for use in FDA Class III (or similar life-critical medical equipment) unless authorized officers of the parties have executed a special agreement specifically governing such use.

Only those TI components which TI has specifically designated as military grade or "enhanced plastic" are designed and intended for use in military/aerospace applications or environments. Buyer acknowledges and agrees that any military or aerospace use of TI components which have **not** been so designated is solely at the Buyer's risk, and that Buyer is solely responsible for compliance with all legal and regulatory requirements in connection with such use.

TI has specifically designated certain components as meeting ISO/TS16949 requirements, mainly for automotive use. In any case of use of non-designated products, TI will not be responsible for any failure to meet ISO/TS16949.

### Products

Audio	<a href="http://www.ti.com/audio">www.ti.com/audio</a>
Amplifiers	<a href="http://amplifier.ti.com">amplifier.ti.com</a>
Data Converters	<a href="http://dataconverter.ti.com">dataconverter.ti.com</a>
DLP® Products	<a href="http://www.dlp.com">www.dlp.com</a>
DSP	<a href="http://dsp.ti.com">dsp.ti.com</a>
Clocks and Timers	<a href="http://www.ti.com/clocks">www.ti.com/clocks</a>
Interface	<a href="http://interface.ti.com">interface.ti.com</a>
Logic	<a href="http://logic.ti.com">logic.ti.com</a>
Power Mgmt	<a href="http://power.ti.com">power.ti.com</a>
Microcontrollers	<a href="http://microcontroller.ti.com">microcontroller.ti.com</a>
RFID	<a href="http://www.ti-rfid.com">www.ti-rfid.com</a>
OMAP Applications Processors	<a href="http://www.ti.com/omap">www.ti.com/omap</a>
Wireless Connectivity	<a href="http://www.ti.com/wirelessconnectivity">www.ti.com/wirelessconnectivity</a>

### Applications

Automotive and Transportation	<a href="http://www.ti.com/automotive">www.ti.com/automotive</a>
Communications and Telecom	<a href="http://www.ti.com/communications">www.ti.com/communications</a>
Computers and Peripherals	<a href="http://www.ti.com/computers">www.ti.com/computers</a>
Consumer Electronics	<a href="http://www.ti.com/consumer-apps">www.ti.com/consumer-apps</a>
Energy and Lighting	<a href="http://www.ti.com/energy">www.ti.com/energy</a>
Industrial	<a href="http://www.ti.com/industrial">www.ti.com/industrial</a>
Medical	<a href="http://www.ti.com/medical">www.ti.com/medical</a>
Security	<a href="http://www.ti.com/security">www.ti.com/security</a>
Space, Avionics and Defense	<a href="http://www.ti.com/space-avionics-defense">www.ti.com/space-avionics-defense</a>
Video and Imaging	<a href="http://www.ti.com/video">www.ti.com/video</a>

### TI E2E Community

[e2e.ti.com](http://e2e.ti.com)