

SN74LVC1404 Oscillator Driver for Crystal Oscillator or Ceramic Resonator

1 Features

- Available in the Texas Instruments NanoFree™ Package
- Supports 5-V V_{CC} Operation
- Inputs Accept Voltages to 5.5 V
- One Buffered Inverter With Schmitt-trigger Input and Two Unbuffered Inverters
- Integrated Solution for Oscillator Applications
- Suitable for Commonly Used Clock Frequencies:
 - 15 kHz, 3.58 MHz, 4.43 MHz, 13 MHz, 25 MHz, 26 MHz, 27 MHz, 28 MHz
- Control Input to Disable the Oscillator Circuit
- Low Power Consumption (10- μ A Max I_{CC}) in Standby State
- ± 24 -mA Output Drive at 3.3 V
- I_{off} Supports Live Insertion, Partial-Power-Down Mode, and Back-Drive Protection
- Latch-Up Performance Exceeds 100 mA Per JESD 78, Class II
- ESD Protection Exceeds JESD 22
 - 2000-V Human-Body Model (A114-A)
 - 200-V Machine Model (A115-A)
 - 1000-V Charged-Device Model (C101)

2 Applications

- Servers
- PCs and Notebooks
- Network Switches
- Wearable Health and Fitness Devices
- Telecom Infrastructures
- Electronic Points of Sale

3 Description

The SN74LVC1404 device consists of one inverter with a Schmitt-trigger input and two unbuffered inverters. It is designed for 1.65-V to 5.5-V V_{CC} operation.

Device Information⁽¹⁾

PART NUMBER	PACKAGE	BODY SIZE (NOM)
SN74LVC1404	SSOP (8)	2.95 mm x 2.80 mm
	VSSOP (8)	2.30 mm x 2.00 mm
	DSBGA (8)	1.91 mm x 0.91 mm

(1) For all available packages, see the orderable addendum at the end of the data sheet.

4 Simplified Schematic

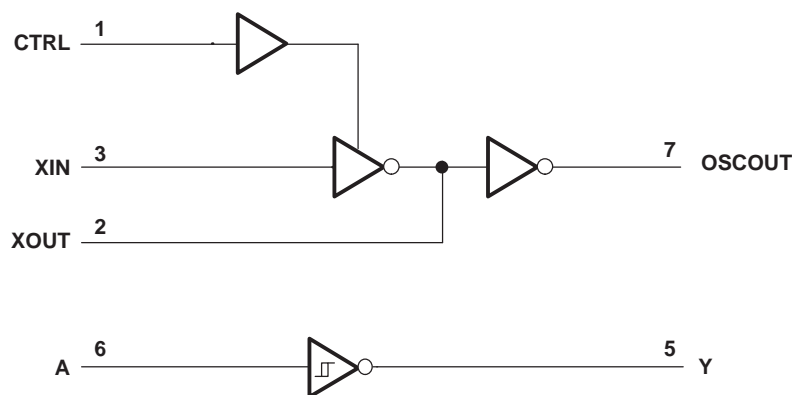

Table of Contents

1 Features	1	9 Detailed Description	10
2 Applications	1	9.1 Overview	10
3 Description	1	9.2 Functional Block Diagram	10
4 Simplified Schematic	1	9.3 Feature Description	10
5 Revision History	2	9.4 Device Functional Modes	11
6 Pin Configuration and Functions	3	10 Application and Implementation	12
7 Specifications	4	10.1 Application Information	12
7.1 Absolute Maximum Ratings	4	10.2 Typical Application	12
7.2 Handling Ratings	4	11 Power Supply Recommendations	17
7.3 Recommended Operating Conditions	5	12 Layout	17
7.4 Thermal Information	5	12.1 Layout Guidelines	17
7.5 Electrical Characteristics	6	12.2 Layout Example	17
7.6 Switching Characteristics, $C_L = 15$ pF	7	13 Device and Documentation Support	18
7.7 Switching Characteristics, $C_L = 30$ pF or 50 pF	7	13.1 Trademarks	18
7.8 Operating Characteristics	7	13.2 Electrostatic Discharge Caution	18
7.9 Typical Characteristics	7	13.3 Glossary	18
8 Parameter Measurement Information	8	14 Mechanical, Packaging, and Orderable Information	18

5 Revision History

NOTE: Page numbers for previous revisions may differ from page numbers in the current version.

Changes from Revision D (January 2007) to Revision E	Page
• Updated document to new TI data sheet format	1
• Removed Ordering Information table.	1
• Added Applications.	1
• Added Device Information table.	1
• Added Handling Ratings table.	4
• Changed MAX ambient temperature to 125°C	5
• Added Thermal Information table.	5
• Added Typical Characteristics.	7

6 Pin Configuration and Functions

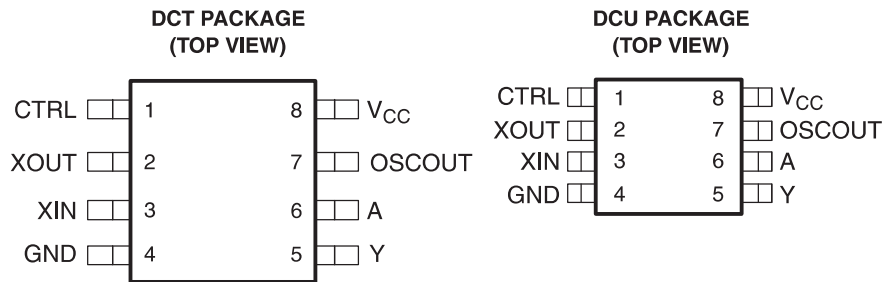

See mechanical drawings for dimensions.

YZP PACKAGE (BOTTOM VIEW)

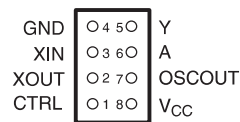

See mechanical drawings for dimensions.

Pin Functions

PIN		I/O	DESCRIPTION
NO.	NAME		
1	CTRL	I	OSC Control
2	XOUT	O	Crystal Connection
3	XIN	I	Crystal Connection
4	GND	—	Ground
5	Y	O	Schmitt Trigger Output
6	A	I	Schmitt Trigger Input
7	OSCOUT	O	Oscillator Output
8	VCC	I	Input 4

7 Specifications

7.1 Absolute Maximum Ratings⁽¹⁾

over operating free-air temperature range (unless otherwise noted)

			MIN	MAX	UNIT
V _{CC}	Supply voltage range		-0.5	6.5	V
V _I	Input voltage range ⁽²⁾	XIN, A, CTRL inputs	-0.5	6.5	V
V _O	Voltage range applied to any output in the high-impedance or power-off state ⁽²⁾		-0.5	6.5	V
V _O	Voltage range applied to any output in the high or low state ⁽²⁾⁽³⁾		-0.5	V _{CC} + 0.5	V
I _{IK}	Input clamp current	V _I < 0		-50	mA
I _{OK}	Output clamp current	V _O < 0		-50	mA
I _O	Continuous output current			±50	mA
	Continuous current through V _{CC} or GND			±100	mA

- (1) Stresses beyond those listed under *Absolute Maximum Ratings* may cause permanent damage to the device. These are stress ratings only, and functional operation of the device at these or any other conditions beyond those indicated under *Recommended Operating Conditions* is not implied. Exposure to absolute-maximum-rated conditions for extended periods may affect device reliability.
- (2) The input and output negative-voltage ratings may be exceeded if the input and output current ratings are observed.
- (3) The value of V_{CC} is provided in the *Recommended Operating Conditions* table.

7.2 Handling Ratings

			MIN	MAX	UNIT
T _{stg}	Storage temperature range		-65	150	°C
V _(ESD)	Electrostatic discharge	Human body model (HBM), per ANSI/ESDA/JEDEC JS-001, all pins ⁽¹⁾	0	2000	V
		Charged device model (CDM), per JEDEC specification JESD22-C101, all pins ⁽²⁾	0	1000	

- (1) JEDEC document JEP155 states that 500-V HBM allows safe manufacturing with a standard ESD control process.
- (2) JEDEC document JEP157 states that 250-V CDM allows safe manufacturing with a standard ESD control process.

7.3 Recommended Operating Conditions

 over operating free-air temperature range (unless otherwise noted)⁽¹⁾

		MIN	MAX	UNIT	
V _{CC}	Supply voltage	Operating	1.65	5.5	V
		Data retention only	1.5		
V _I	Input voltage (XIN, CTRL, A inputs)	0	5.5	V	
V _O	Output voltage (XOUT, OSCOUT, Y outputs)	0	V _{CC}	V	
I _{OH}	High-level output current (OSCOUT, XOUT, Y outputs)	V _{CC} = 1.65 V		–4	mA
		V _{CC} = 2.3 V		–8	
		V _{CC} = 3 V		–16	
		V _{CC} = 4.5 V		–24	
I _{OL}	Low-level output current (OSCOUT, XOUT, Y outputs)	V _{CC} = 1.65 V		4	mA
		V _{CC} = 2.3 V		8	
		V _{CC} = 3 V		16	
		V _{CC} = 4.5 V		24	
I _{OL} ⁽²⁾	Low-level output current (XOUT)	V _{CC} = 1.65 V		2	mA
Δt/Δv	Input transition rise and fall time (CTRL input)	V _{CC} = 1.8 V ± 0.15 V		20	ns/V
		V _{CC} = 2.5 V ± 0.2 V		20	
		V _{CC} = 3.3 V ± 0.3 V		10	
		V _{CC} = 5 V ± 0.5 V		5	
T _A	Operating free-air temperature		–40	125	°C

(1) All unused inputs of the device must be held at V_{CC} or GND to ensure proper device operation. Refer to the TI application report, *Implications of Slow or Floating CMOS Inputs*, literature number [SCBA004](#).

(2) CTRL = Low, XIN = GND

7.4 Thermal Information

THERMAL METRIC ⁽¹⁾		DCT	DCU	UNIT
		8 PINS	8 PINS	
R _{θJA}	Junction-to-ambient thermal resistance	184.8	198.4	°C/W
R _{θJC(top)}	Junction-to-case (top) thermal resistance	115.3	73.5	
R _{θJB}	Junction-to-board thermal resistance	97.3	77.1	
ψ _{JT}	Junction-to-top characterization parameter	40.9	6.1	
ψ _{JB}	Junction-to-board characterization parameter	96.3	76.7	
R _{θJC(bot)}	Junction-to-case (bottom) thermal resistance	n/a	n/a	

(1) For more information about traditional and new thermal metrics, see the *IC Package Thermal Metrics* application report, [SPRA953](#).

7.5 Electrical Characteristics

over recommended operating free-air temperature range (unless otherwise noted)

PARAMETER		TEST CONDITIONS		V _{CC}	MIN	TYP ⁽¹⁾	MAX	UNIT
V _{T+} Positive-going threshold	A input			1.65 V	0.79		1.16	V
				2.3 V	1.11		1.56	
				3 V	1.5		1.87	
				4.5 V	2.16		2.74	
				5.5 V	2.61		3.33	
V _{T-} Negative-going threshold	A input			1.65 V	0.39		0.62	V
				2.3 V	0.58		0.87	
				3 V	0.84		1.14	
				4.5 V	1.41		1.79	
				5.5 V	1.87		2.29	
ΔV _T hysteresis (V _{T+} – V _{T-})	A input			1.65 V	0.37		0.62	V
				2.3 V	0.48		0.77	
				3 V	0.56		0.87	
				4.5 V	0.71		1.04	
				5.5 V	0.71		1.11	
V _{OH} ⁽²⁾			I _{OH} = –100 μA	1.65 V to 5.5 V	V _{CC} – 0.1			V
			I _{OH} = –4 mA	1.65 V	1.2			
			I _{OH} = –8 mA	2.3 V	1.9			
			I _{OH} = –16 mA	3 V	2.4			
			I _{OH} = –24 mA	3 V	2.3			
			I _{OH} = –32 mA	4.5 V	3.8			
V _{OL} ⁽²⁾			I _{OL} = 100 μA	1.65 V to 5.5 V			0.1	V
			I _{OL} = 4 mA	1.65 V			0.45	
			I _{OL} = 8 mA	2.3 V			0.3	
			I _{OL} = 16 mA	3 V			0.4	
			I _{OL} = 24 mA	3 V			0.55	
			I _{OL} = 32 mA	4.5 V			0.55	
V _{OL}	XOUT			I _{OL} = 100 μA	1.65 V to 5.5 V		0.1	V
				I _{OL} = 2 mA	1.65 V		0.65	
I _I	All inputs	V _I = 5.5 V or GND		0 to 5.5 V			±5	μA
I _{off}	Y output	V _I or V _O = 0 to 5.5 V		0			±10	μA
I _{CC}			V _I = V _{CC} or GND, I _O = 0	1.65 V to 5.5 V			10	μA
ΔI _{CC}	CTRL and A inputs	One input at V _{CC} – 0.6 V, Other inputs at V _{CC} or GND		3 V to 5.5 V			500	μA
C _i	CTRL and A inputs	V _I = V _{CC} or GND		3.3 V			3.5	pF
	XIN						6	

 (1) All typical values are at V_{CC} = 3.3 V, T_A = 25°C.

 (2) V_{IL} = 0 V and V_{IH} = V_{CC} for XOUT and OSCOUT; the standard V_{T+} and V_{T-} levels should be applied for the Y output.

7.6 Switching Characteristics, $C_L = 15 \text{ pF}$

over recommended operating free-air temperature range (unless otherwise noted) (see Figure 2)

PARAMETER	FROM (INPUT)	TO (OUTPUT)	$V_{CC} = 1.8 \text{ V} \pm 0.15 \text{ V}$		$V_{CC} = 2.5 \text{ V} \pm 0.2 \text{ V}$		$V_{CC} = 3.3 \text{ V} \pm 0.3 \text{ V}$		$V_{CC} = 5 \text{ V} \pm 0.5 \text{ V}$		UNIT
			MIN	MAX	MIN	MAX	MIN	MAX	MIN	MAX	
t_{pd}	A	Y	2.8	15.1	1.6	5.7	1.5	4.6	0.9	4.4	ns
	XIN	XOUT	1.7	9.6	1	3.2	1.1	2.4	0.9	1.8	
		OSCOUT	2.6	17.2	2	5.6	2	4.1	1.5	3.2	
	CTRL	XOUT	3	28.2	1.8	14.4	1.5	12.2	1.1	10.2	

7.7 Switching Characteristics, $C_L = 30 \text{ pF}$ or 50 pF

over recommended operating free-air temperature range (unless otherwise noted) (see Figure 3)

PARAMETER	FROM (INPUT)	TO (OUTPUT)	$V_{CC} = 1.8 \text{ V} \pm 0.15 \text{ V}$		$V_{CC} = 2.5 \text{ V} \pm 0.2 \text{ V}$		$V_{CC} = 3.3 \text{ V} \pm 0.3 \text{ V}$		$V_{CC} = 5 \text{ V} \pm 0.5 \text{ V}$		UNIT
			MIN	MAX	MIN	MAX	MIN	MAX	MIN	MAX	
t_{pd}	A	Y	3	17.3	1.8	7.4	1.8	6.4	1	5.3	ns
	XIN	XOUT	1.2	15.8	0.8	5.8	1	5.4	0.6	4.6	
		OSCOUT	3.5	25.7	2.6	7.1	2.8	7.8	2	6.7	
	CTRL	XOUT	3.3	24.5	2.1	12	1.9	12.7	1.1	11.2	

7.8 Operating Characteristics

$T_A = 25^\circ\text{C}$

PARAMETER	TEST CONDITIONS	$V_{CC} = 1.8 \text{ V}$	$V_{CC} = 2.5 \text{ V}$	$V_{CC} = 3.3 \text{ V}$	$V_{CC} = 5 \text{ V}$	UNIT
		TYP	TYP	TYP	TYP	
C_{pd} Power dissipation capacitance	$f = 10 \text{ MHz}$	25	26	29	39	pF

7.9 Typical Characteristics

Figure 1 shows the open-loop-gain characteristics of the unbuffered inverter of the LVC1404 (that is, between XIN and XOUT). The device provides a high gain over a wide range of frequencies.

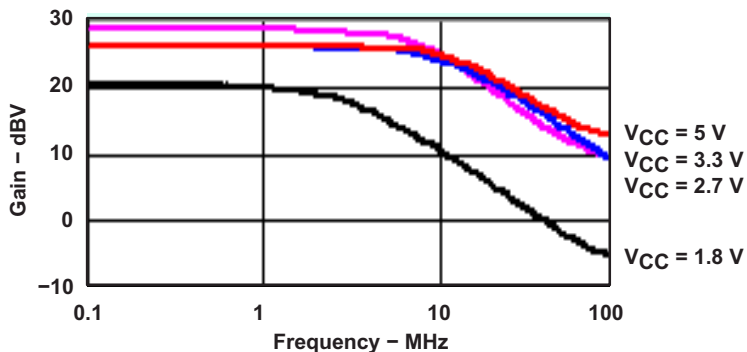
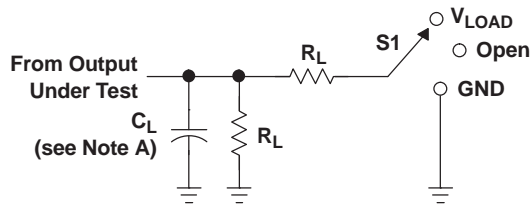

Figure 1. Open-Loop-Gain Characteristics

8 Parameter Measurement Information

LOAD CIRCUIT

TEST	S1
t_{PLH}/t_{PHL}	Open
t_{PLZ}/t_{PZL}	V_{LOAD}
t_{PHZ}/t_{PZH}	GND

V_{CC}	INPUTS		V_M	V_{LOAD}	C_L	R_L (Except t_{pZ})	R_L (t_{pZ})	V_{Δ}
	V_I	t_r/t_f						
$1.8\text{ V} \pm 0.15\text{ V}$	V_{CC}	$\leq 2\text{ ns}$	$V_{CC}/2$	$2 \times V_{CC}$	15 pF	1 M Ω	1 k Ω	0.15 V
$2.5\text{ V} \pm 0.2\text{ V}$	V_{CC}	$\leq 2\text{ ns}$	$V_{CC}/2$	$2 \times V_{CC}$	15 pF	1 M Ω	1 k Ω	0.15 V
$3.3\text{ V} \pm 0.3\text{ V}$	3 V	$\leq 2.5\text{ ns}$	1.5 V	6 V	15 pF	1 M Ω	1 k Ω	0.3 V
$5\text{ V} \pm 0.5\text{ V}$	V_{CC}	$\leq 2.5\text{ ns}$	$V_{CC}/2$	$2 \times V_{CC}$	15 pF	1 M Ω	1 k Ω	0.3 V

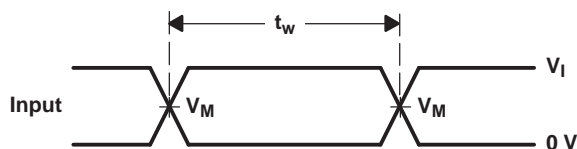
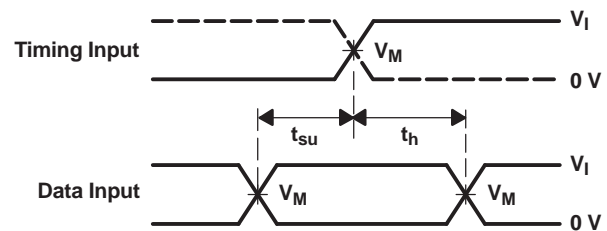
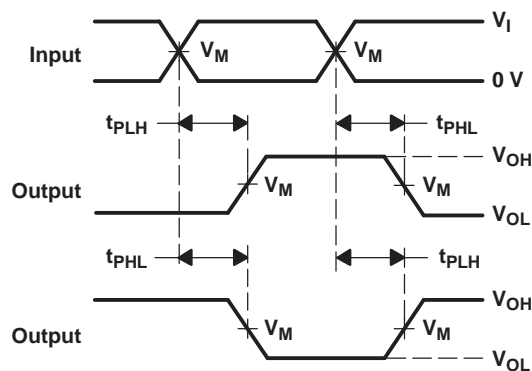
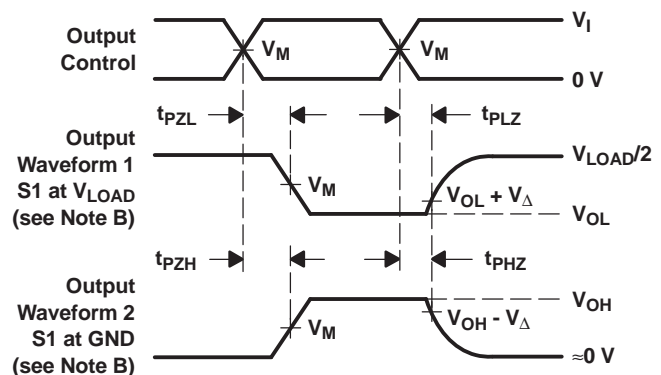
**VOLTAGE WAVEFORMS
PULSE DURATION**

**VOLTAGE WAVEFORMS
SETUP AND HOLD TIMES**

**VOLTAGE WAVEFORMS
PROPAGATION DELAY TIMES**

**VOLTAGE WAVEFORMS
ENABLE AND DISABLE TIMES**

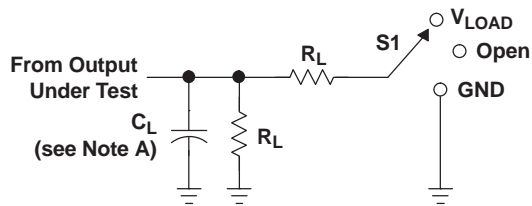
- NOTES:
- C_L includes probe and jig capacitance.
 - Waveform 1 is for an output with internal conditions such that the output is low, except when disabled by the output control. Waveform 2 is for an output with internal conditions such that the output is high, except when disabled by the output control.
 - All input pulses are supplied by generators having the following characteristics: $PRR \leq 10\text{ MHz}$, $Z_O = 50\ \Omega$.
 - The outputs are measured one at a time, with one transition per measurement.
 - t_{pLZ} and t_{pHZ} are the same as t_{dis} .
 - t_{pZL} and t_{pZH} are the same as t_{en} .
 - t_{pLH} and t_{pHL} are the same as t_{pd} .
 - All parameters and waveforms are not applicable to all devices.

Figure 2. Load Circuit and Voltage Waveforms

Parameter Measurement Information (continued)



LOAD CIRCUIT

TEST	S1
t_{PLH}/t_{PHL}	Open
t_{PLZ}/t_{PZL}	V_{LOAD}
t_{PHZ}/t_{PZH}	GND

V_{CC}	INPUTS		V_M	V_{LOAD}	C_L	R_L	V_{Δ}
	V_I	t_r/t_f					
$1.8\text{ V} \pm 0.15\text{ V}$	V_{CC}	$\leq 2\text{ ns}$	$V_{CC}/2$	$2 \times V_{CC}$	30 pF	1 k Ω	0.15 V
$2.5\text{ V} \pm 0.2\text{ V}$	V_{CC}	$\leq 2\text{ ns}$	$V_{CC}/2$	$2 \times V_{CC}$	30 pF	500 Ω	0.15 V
$3.3\text{ V} \pm 0.3\text{ V}$	3 V	$\leq 2.5\text{ ns}$	1.5 V	6 V	50 pF	500 Ω	0.3 V
$5\text{ V} \pm 0.5\text{ V}$	V_{CC}	$\leq 2.5\text{ ns}$	$V_{CC}/2$	$2 \times V_{CC}$	50 pF	500 Ω	0.3 V

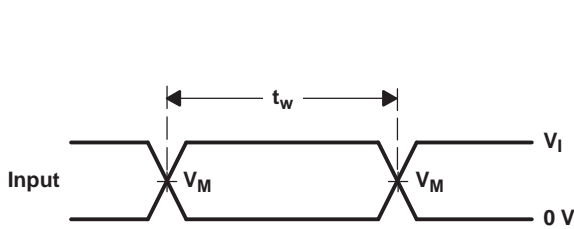

VOLTAGE WAVEFORMS PULSE DURATION

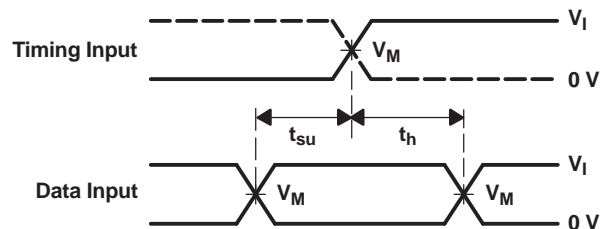

VOLTAGE WAVEFORMS SETUP AND HOLD TIMES

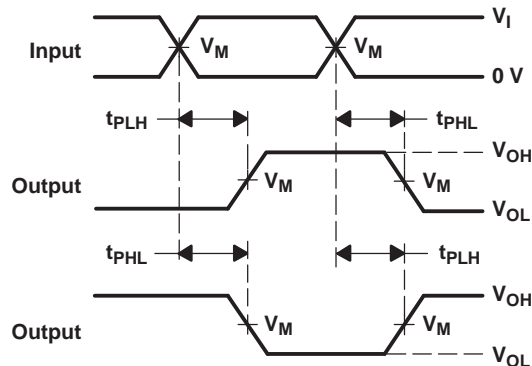

VOLTAGE WAVEFORMS PROPAGATION DELAY TIMES

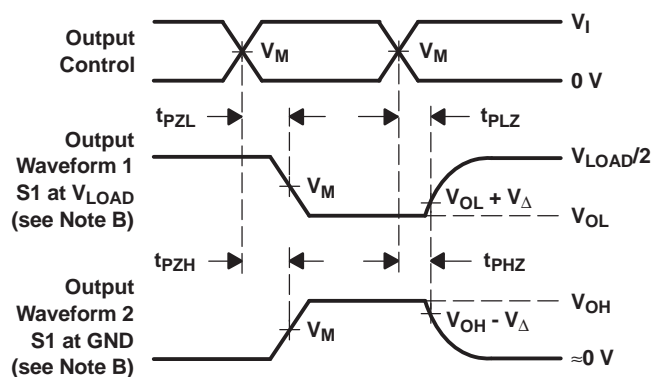

VOLTAGE WAVEFORMS ENABLE AND DISABLE TIMES

- NOTES:
- A. C_L includes probe and jig capacitance.
 - B. Waveform 1 is for an output with internal conditions such that the output is low, except when disabled by the output control. Waveform 2 is for an output with internal conditions such that the output is high, except when disabled by the output control.
 - C. All input pulses are supplied by generators having the following characteristics: $PRR \leq 10\text{ MHz}$, $Z_O = 50\ \Omega$.
 - D. The outputs are measured one at a time, with one transition per measurement.
 - E. t_{PLZ} and t_{PHZ} are the same as t_{dis} .
 - F. t_{PZL} and t_{PZH} are the same as t_{en} .
 - G. t_{PLH} and t_{PHL} are the same as t_{pd} .
 - H. All parameters and waveforms are not applicable to all devices.

Figure 3. Load Circuit and Voltage Waveforms

9 Detailed Description

9.1 Overview

The SN74LVC1404 device consists of one inverter with a Schmitt-trigger input and two unbuffered inverters. It is designed for 1.65-V to 5.5-V V_{CC} operation.

XIN and XOUT pins can be connected to a crystal or resonator in oscillator applications. The SN74LVC1404 device provides an additional unbuffered inverter (OSCOUT) and a Schmitt-trigger input inverter for signal conditioning (see the [Functional Block Diagram](#)). The control (CTRL) input disables the oscillator circuit to reduce power consumption. The oscillator circuit is disabled and the XOUT output is set to low level when CTRL is low. To ensure the oscillator circuit remains disabled during power up or power down, CTRL should be connected to GND through a pull-down resistor. The minimum value of the resistor is determined by the current-sourcing capability of the driver.

This device is fully specified for partial-power-down applications using I_{off} . The I_{off} circuitry disables the outputs, preventing damaging current backflow through the device when it is powered down.

NanoFree™ package technology is a major breakthrough in IC packaging concepts, using the die as the package.

9.2 Functional Block Diagram

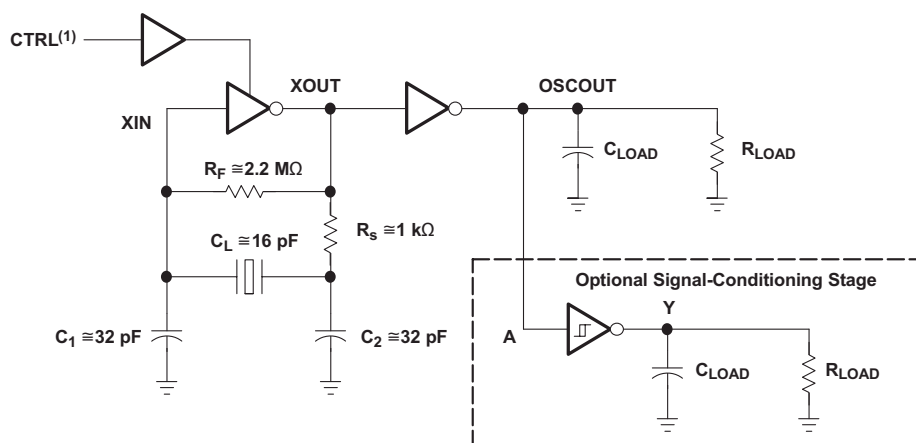

9.3 Feature Description

- Wide operating voltage range
 - Operates from 1.65 V to 5.5 V
- Has buffered output and un-buffered output from oscillator
- Schmitt-trigger buffer
 - Allows for extra buffering of the oscillator output
- I_{off} feature
 - Allows voltages on the inputs and outputs when V_{CC} is 0 V

9.4 Device Functional Modes

Table 1. Function Table

INPUTS		OUTPUTS	
CTRL	XIN	XOUT	OSCOUT
H	L	H	L
H	H	L	H
L	X	L	H

Table 2. Function Table

INPUT A	OUTPUT Y
L	H
H	L

Typical Application (continued)

10.2.1 Design Requirements

- The open-loop gain of the unbuffered inverter decreases as power-supply voltage decreases. This decreases the closed-loop gain of the oscillator circuit. The value of R_s can be decreased to increase the closed-loop gain, while maintaining the power dissipation of the crystal within the maximum limit.
- R_s and C_2 form a low-pass filter and reduce spurious oscillations. Component values can be adjusted, based on the desired cutoff frequency.
- C_2 can be increased over C_1 to increase the phase shift and help in start-up of the oscillator. Increasing C_2 may affect the duty cycle of the output voltage.
- At high frequency, phase shift due to R_s becomes significant. In this case, R_s can be replaced by a capacitor to reduce the phase shift.

10.2.2 Detailed Design Procedure

1. Recommended Input Conditions
 - Rise time and fall time specs: See $(\Delta t/\Delta V)$ in the [Recommended Operating Conditions](#) table.
 - Specified high and low levels: See $(V_{IH}$ and $V_{IL})$ in the [Recommended Operating Conditions](#) table.
 - Inputs are overvoltage tolerant allowing them to go as high as 5.5 V at any valid V_{CC} .
2. Recommend Output Conditions
 - Load currents should not exceed 50 mA per output and 100 mA total for the part.
 - Outputs should not be pulled above V_{CC} .

10.2.2.1 Testing

After the selection of proper component values, the oscillator circuit should be tested, using these components, to ensure that the oscillator circuit shows required performance over the recommended operating conditions.

- Without a crystal, the oscillator circuit should not oscillate. To check this, the crystal can be replaced by its equivalent parallel-resonant resistance.
- When the power-supply voltage drops, the closed-loop gain of the oscillator circuit reduces. Ensure that the circuit oscillates at the appropriate frequency at the lowest V_{CC} and highest V_{CC} .
- Ensure that the duty cycle, start-up time, and frequency drift over time is within the system requirements.

Typical Application (continued)
10.2.3 Application Curves
10.2.3.1 LVC1404 in 25-MHz Crystal-Oscillator Circuit

$$C_1 \approx C_2 = 30 \text{ pF} \quad (1)$$

$$X_{C2} = 200 \ \Omega \text{ (capacitive reactance at resonance frequency, that is, 25 MHz)} \quad (2)$$

$$V_{CC} = 3.3 \text{ V} \quad (3)$$

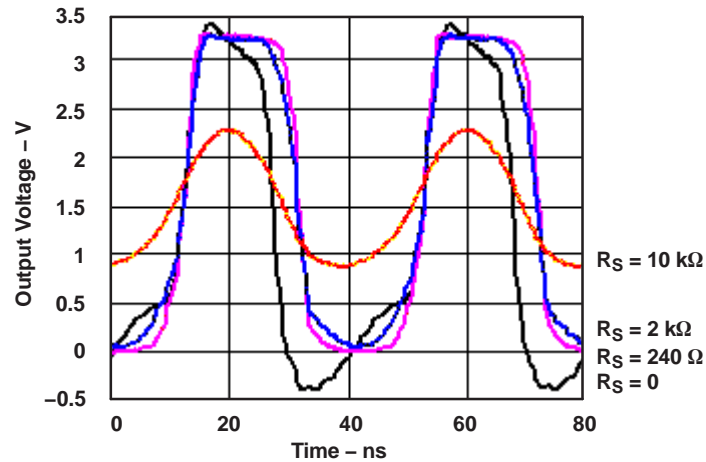
Figure 5. Effect of R_S on Oscillator Waveform (Frequency = 25 MHz)
Table 3. Effect of R_S on Duty Cycle and I_{CC} (Frequency = 25 MHz)

R_S (Ω)	I_{CC} (mA)	Positive Duty Cycle (%)
0	22.2	43
240	11.1	45.9
2 k	7.3	47.3
10 k	8.6	46.7

10.2.3.2 LVC1404 in 10-MHz Crystal-Oscillator Circuit

$C_1 \approx C_2 = 30 \text{ pF}$ (4)

$X_{C2} = 480 \text{ } \Omega$ (capacitive reactance at resonance frequency, that is, 10 MHz) (5)

$V_{CC} = 3.3 \text{ V}$ (6)

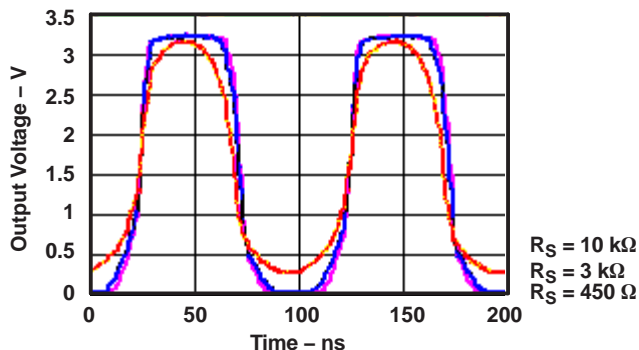

Figure 6. Effect of R_S on Oscillator Waveform (Frequency = 10 MHz)

Table 4. Effect of R_S on Duty Cycle and I_{CC} (Frequency = 10 MHz)

R_S (Ω)	I_{CC} (mA)	Positive Duty Cycle (%)
450	6.9	40
3 k	8.4	47.6
10 k	15.1	43.9

10.2.3.3 LVC1404 in 2-MHz Crystal-Oscillator Circuit

$C_1 \approx C_2 = 30 \text{ pF}$ (7)

$X_{C2} = 2.4 \text{ k}\Omega$ (capacitive reactance at resonance frequency, that is, 2 MHz) (8)

$V_{CC} = 3.3 \text{ V}$ (9)

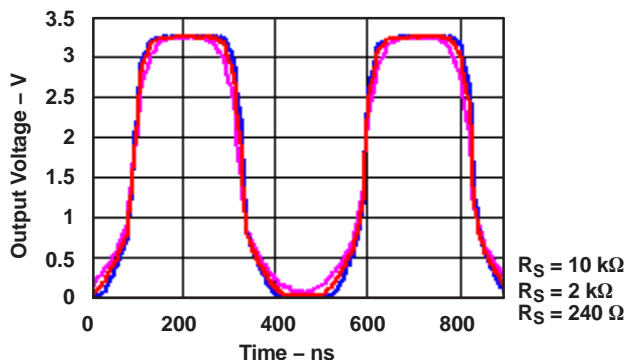

Figure 7. Effect of R_S on Oscillator Waveform (Frequency = 2 MHz)

Table 5. Effect of R_S on Duty Cycle and I_{CC} (Frequency = 2 MHz)

R_S (Ω)	I_{CC} (mA)	Positive Duty Cycle (%)
240	11.1	45.9
2 k	7.3	47.3
10 k	8.6	46.7

10.2.3.4 LVC1404 in 100-kHz Crystal-Oscillator Circuit

$$C_1 \approx C_2 = 30 \text{ pF} \quad (10)$$

$$X_{C2} = 48 \text{ k}\Omega \text{ (capacitive reactance at resonance frequency, that is, 100 kHz)} \quad (11)$$

$$V_{CC} = 3.3 \text{ V} \quad (12)$$

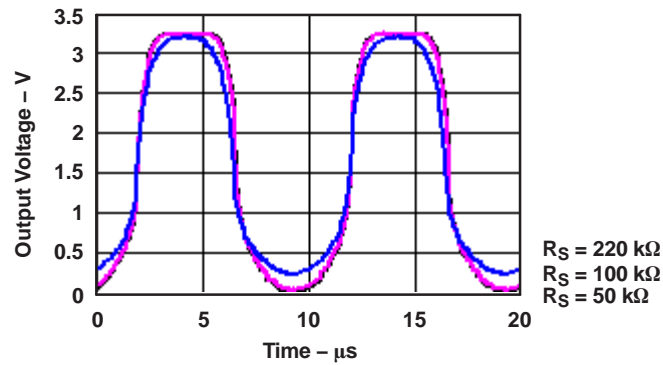
Figure 8. Effect of R_S on Oscillator Waveform (Frequency = 100 kHz)
Table 6. Effect of R_S on Duty Cycle and I_{CC} (Frequency = 100 kHz)

R_S (Ω)	I_{CC} (mA)	Positive Duty Cycle (%)
50 k	9	46.4
100 k	9.5	46.1
220 k	13.7	44.3

11 Power Supply Recommendations

The power supply can be any voltage between the MIN and MAX supply voltage rating located in the [Recommended Operating Conditions](#) table.

Each V_{CC} pin should have a good bypass capacitor to prevent power disturbance. For devices with a single supply, 0.1 μf is recommended; if there are multiple V_{CC} pins, then 0.01 μf or 0.022 μf is recommended for each power pin. It is acceptable to parallel multiple bypass caps to reject different frequencies of noise. A 0.1 μf and a 1 μf are commonly used in parallel. The bypass capacitor should be installed as close to the power pin as possible for best results.

12 Layout

12.1 Layout Guidelines

When using multiple-bit logic devices, inputs should never float.

In many cases, functions or parts of functions of digital logic devices are unused, for example, when only two inputs of a triple-input AND gate are used or only 3 of the 4 buffer gates are used. Such input pins should not be left unconnected because the undefined voltages at the outside connections result in undefined operational states. [Figure 9](#) specifies the rules that must be observed under all circumstances. All unused inputs of digital logic devices must be connected to a high or low bias to prevent them from floating. The logic level that should be applied to any particular unused input depends on the function of the device. Generally they will be tied to GND or V_{CC} , whichever makes more sense or is more convenient. It is generally acceptable to float outputs, unless the part is a transceiver. If the transceiver has an output enable pin, it will disable the output section of the part when asserted. This will not disable the input section of the I/Os, so they cannot float when disabled.

12.2 Layout Example

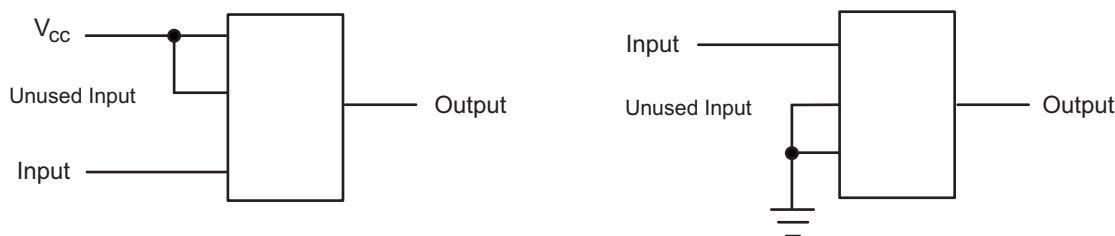

Figure 9. Layout Diagram

13 Device and Documentation Support

13.1 Trademarks

NanoFree is a trademark of Texas Instruments.
All other trademarks are the property of their respective owners.

13.2 Electrostatic Discharge Caution



These devices have limited built-in ESD protection. The leads should be shorted together or the device placed in conductive foam during storage or handling to prevent electrostatic damage to the MOS gates.

13.3 Glossary

[SLYZ022](#) — *TI Glossary*.

This glossary lists and explains terms, acronyms, and definitions.

14 Mechanical, Packaging, and Orderable Information

The following pages include mechanical, packaging, and orderable information. This information is the most current data available for the designated devices. This data is subject to change without notice and revision of this document. For browser-based versions of this data sheet, refer to the left-hand navigation.

PACKAGING INFORMATION

Orderable Device	Status (1)	Package Type	Package Drawing	Pins	Package Qty	Eco Plan (2)	Lead/Ball Finish (6)	MSL Peak Temp (3)	Op Temp (°C)	Device Marking (4/5)	Samples
SN74LVC1404DCTR	ACTIVE	SM8	DCT	8	3000	Green (RoHS & no Sb/Br)	CU NIPDAU	Level-1-260C-UNLIM	-40 to 125	CA4 Z	Samples
SN74LVC1404DCUR	ACTIVE	VSSOP	DCU	8	3000	Green (RoHS & no Sb/Br)	CU NIPDAU	Level-1-260C-UNLIM	-40 to 125	CA4R	Samples
SN74LVC1404YZPR	ACTIVE	DSBGA	YZP	8	3000	Green (RoHS & no Sb/Br)	SNAGCU	Level-1-260C-UNLIM	-40 to 85	(447 ~ 44N)	Samples

(1) The marketing status values are defined as follows:

ACTIVE: Product device recommended for new designs.

LIFEBUY: TI has announced that the device will be discontinued, and a lifetime-buy period is in effect.

NRND: Not recommended for new designs. Device is in production to support existing customers, but TI does not recommend using this part in a new design.

PREVIEW: Device has been announced but is not in production. Samples may or may not be available.

OBSOLETE: TI has discontinued the production of the device.

(2) Eco Plan - The planned eco-friendly classification: Pb-Free (RoHS), Pb-Free (RoHS Exempt), or Green (RoHS & no Sb/Br) - please check <http://www.ti.com/productcontent> for the latest availability information and additional product content details.

TBD: The Pb-Free/Green conversion plan has not been defined.

Pb-Free (RoHS): TI's terms "Lead-Free" or "Pb-Free" mean semiconductor products that are compatible with the current RoHS requirements for all 6 substances, including the requirement that lead not exceed 0.1% by weight in homogeneous materials. Where designed to be soldered at high temperatures, TI Pb-Free products are suitable for use in specified lead-free processes.

Pb-Free (RoHS Exempt): This component has a RoHS exemption for either 1) lead-based flip-chip solder bumps used between the die and package, or 2) lead-based die adhesive used between the die and leadframe. The component is otherwise considered Pb-Free (RoHS compatible) as defined above.

Green (RoHS & no Sb/Br): TI defines "Green" to mean Pb-Free (RoHS compatible), and free of Bromine (Br) and Antimony (Sb) based flame retardants (Br or Sb do not exceed 0.1% by weight in homogeneous material)

(3) MSL, Peak Temp. - The Moisture Sensitivity Level rating according to the JEDEC industry standard classifications, and peak solder temperature.

(4) There may be additional marking, which relates to the logo, the lot trace code information, or the environmental category on the device.

(5) Multiple Device Markings will be inside parentheses. Only one Device Marking contained in parentheses and separated by a "~" will appear on a device. If a line is indented then it is a continuation of the previous line and the two combined represent the entire Device Marking for that device.

(6) Lead/Ball Finish - Orderable Devices may have multiple material finish options. Finish options are separated by a vertical ruled line. Lead/Ball Finish values may wrap to two lines if the finish value exceeds the maximum column width.

Important Information and Disclaimer: The information provided on this page represents TI's knowledge and belief as of the date that it is provided. TI bases its knowledge and belief on information provided by third parties, and makes no representation or warranty as to the accuracy of such information. Efforts are underway to better integrate information from third parties. TI has taken and

continues to take reasonable steps to provide representative and accurate information but may not have conducted destructive testing or chemical analysis on incoming materials and chemicals. TI and TI suppliers consider certain information to be proprietary, and thus CAS numbers and other limited information may not be available for release.

In no event shall TI's liability arising out of such information exceed the total purchase price of the TI part(s) at issue in this document sold by TI to Customer on an annual basis.

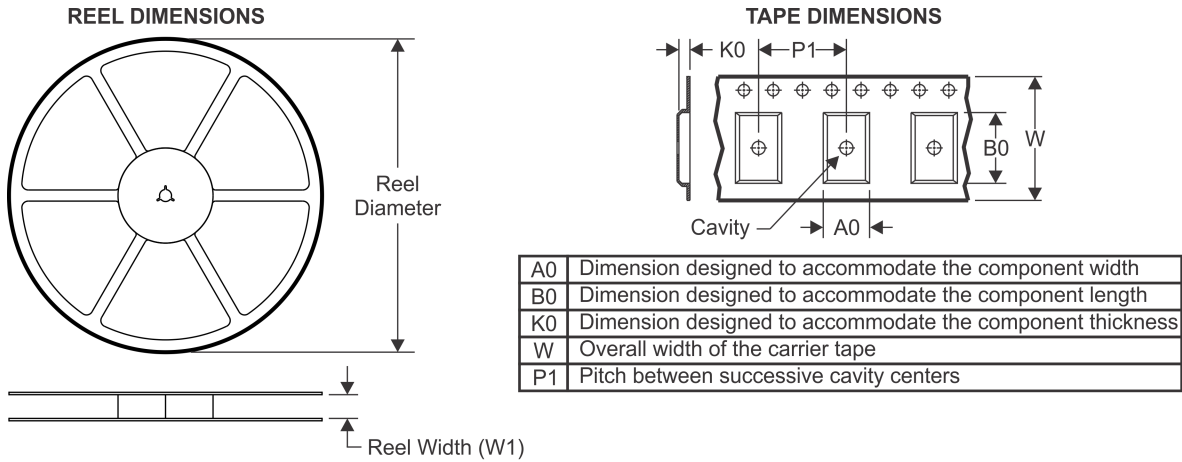
TAPE AND REEL INFORMATION

QUADRANT ASSIGNMENTS FOR PIN 1 ORIENTATION IN TAPE

*All dimensions are nominal

Device	Package Type	Package Drawing	Pins	SPQ	Reel Diameter (mm)	Reel Width W1 (mm)	A0 (mm)	B0 (mm)	K0 (mm)	P1 (mm)	W (mm)	Pin1 Quadrant
SN74LVC1404DCUR	VSSOP	DCU	8	3000	180.0	8.4	2.25	3.35	1.05	4.0	8.0	Q3
SN74LVC1404YZPR	DSBGA	YZP	8	3000	178.0	9.2	1.02	2.02	0.63	4.0	8.0	Q1

TAPE AND REEL BOX DIMENSIONS

*All dimensions are nominal

Device	Package Type	Package Drawing	Pins	SPQ	Length (mm)	Width (mm)	Height (mm)
SN74LVC1404DCUR	VSSOP	DCU	8	3000	202.0	201.0	28.0
SN74LVC1404YZPR	DSBGA	YZP	8	3000	220.0	220.0	35.0

DCT (R-PDSO-G8)

PLASTIC SMALL OUTLINE

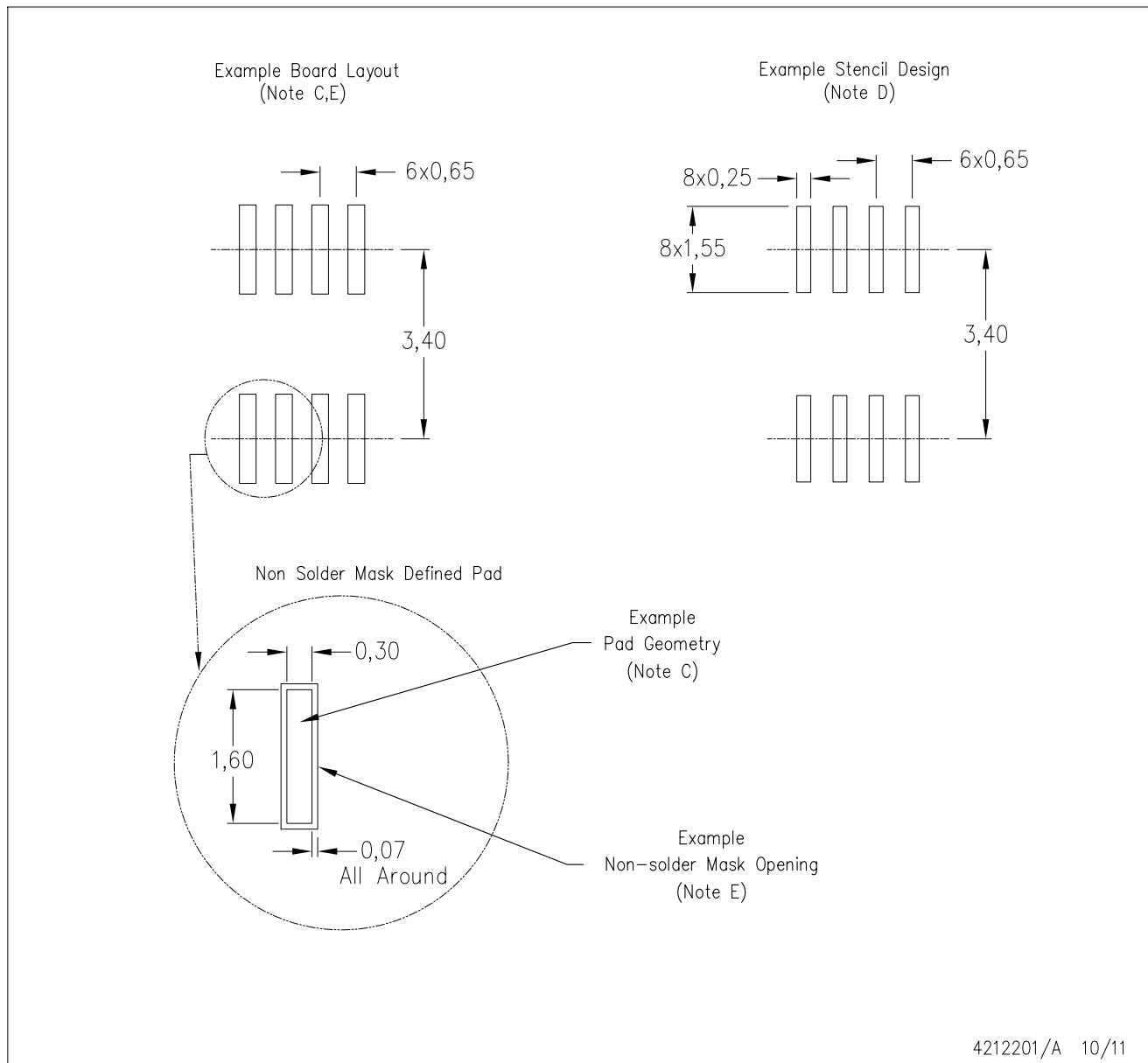

- NOTES:
- A. All linear dimensions are in millimeters.
 - B. This drawing is subject to change without notice.
 - C. Publication IPC-7351 is recommended for alternate designs.
 - D. Laser cutting apertures with trapezoidal walls and also rounding corners will offer better paste release. Customers should contact their board assembly site for stencil design recommendations. Refer to IPC-7525.
 - E. Customers should contact their board fabrication site for solder mask tolerances between and around signal pads.

DCU (S-PDSO-G8)

PLASTIC SMALL OUTLINE PACKAGE (DIE DOWN)

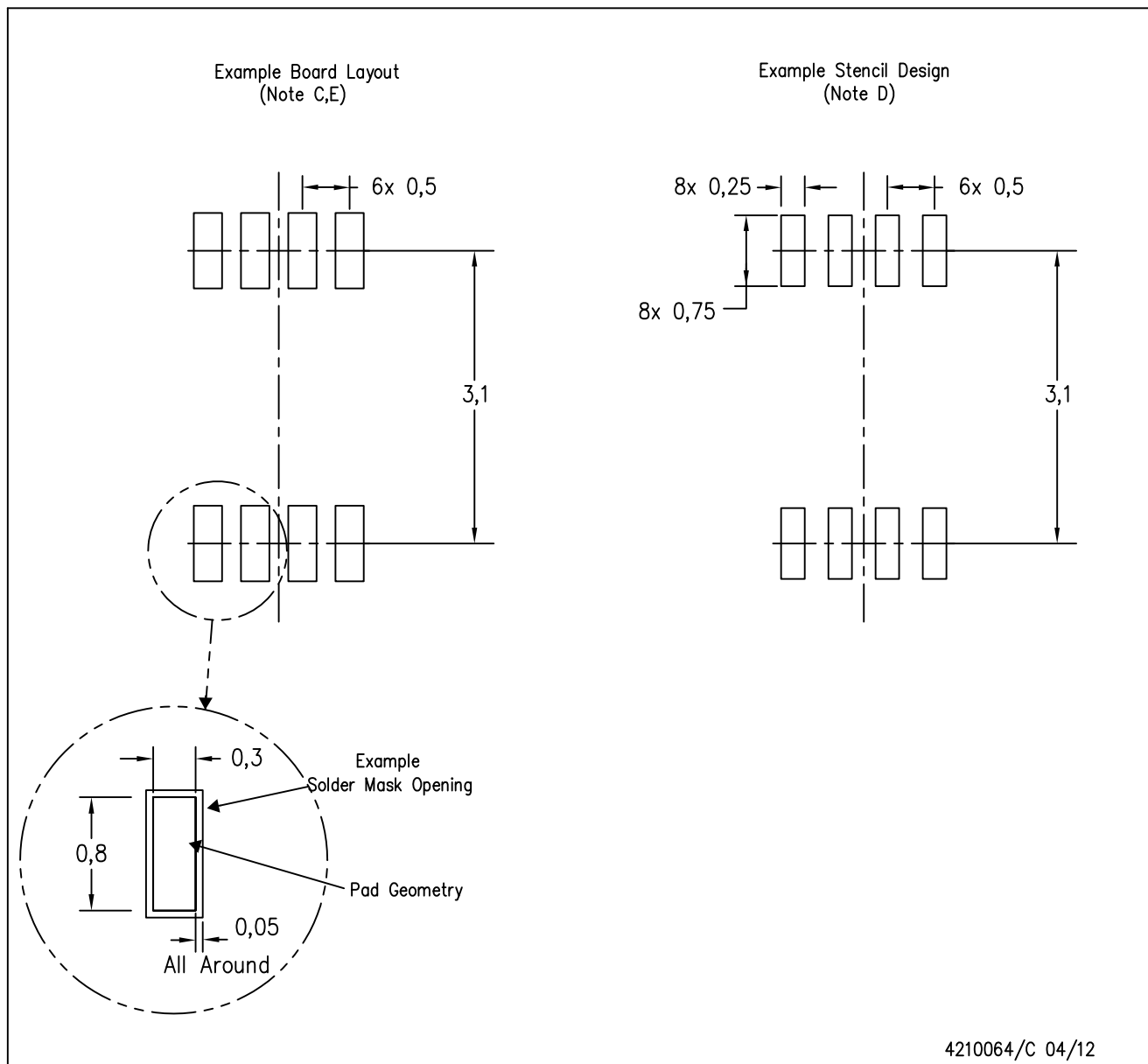

- NOTES:
- A. All linear dimensions are in millimeters.
 - B. This drawing is subject to change without notice.
 - C. Publication IPC-7351 is recommended for alternate designs.
 - D. Laser cutting apertures with trapezoidal walls and also rounding corners will offer better paste release. Customers should contact their board assembly site for stencil design recommendations. Refer to IPC-7525 for other stencil recommendations.
 - E. Customers should contact their board fabrication site for solder mask tolerances between and around signal pads.

YZP (R-XBGA-N8)

DIE-SIZE BALL GRID ARRAY

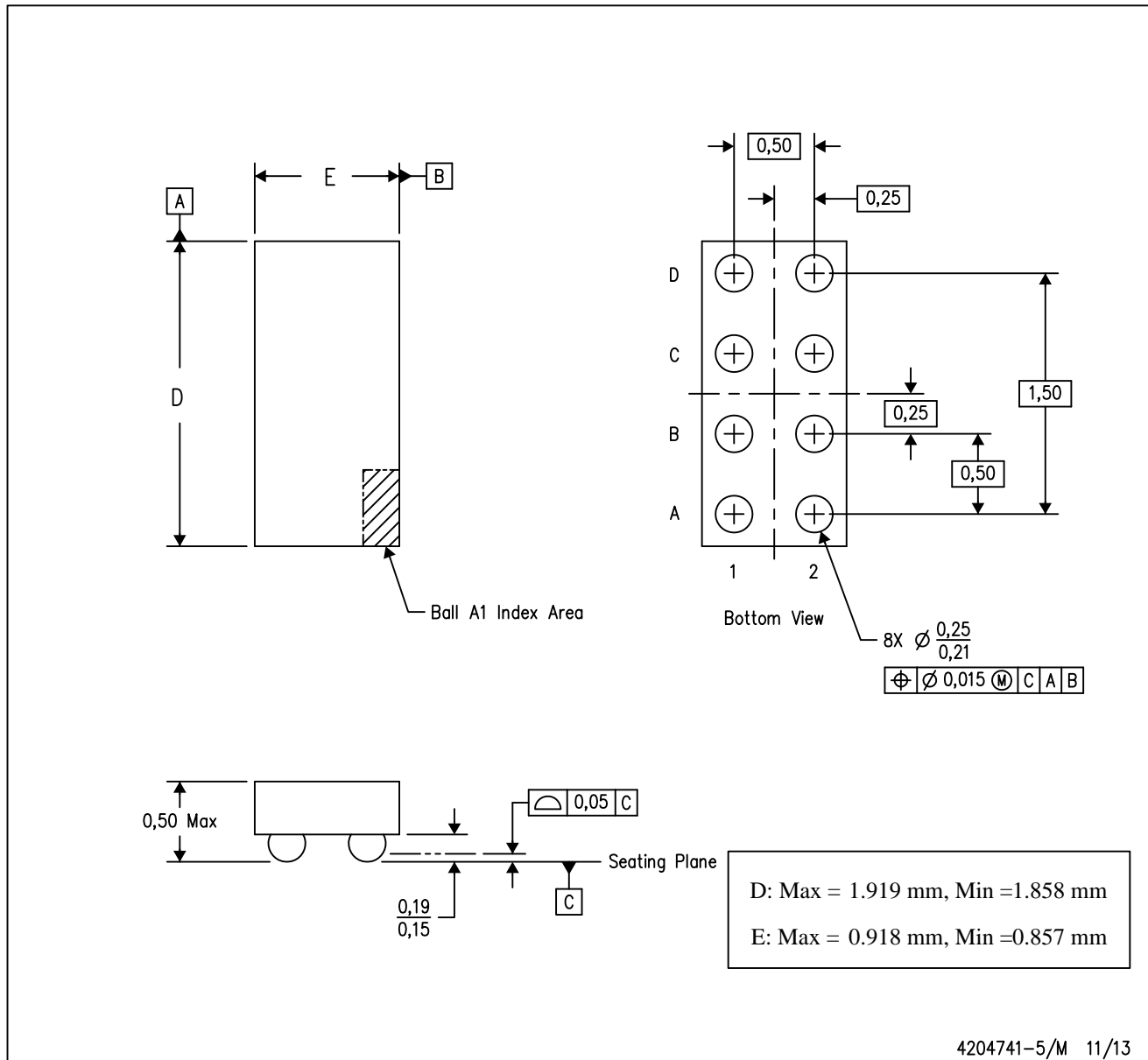

- NOTES:
- A. All linear dimensions are in millimeters. Dimensioning and tolerancing per ASME Y14.5M-1994.
 - B. This drawing is subject to change without notice.
 - C. NanoFree™ package configuration.

NanoFree is a trademark of Texas Instruments.

IMPORTANT NOTICE

Texas Instruments Incorporated and its subsidiaries (TI) reserve the right to make corrections, enhancements, improvements and other changes to its semiconductor products and services per JESD46, latest issue, and to discontinue any product or service per JESD48, latest issue. Buyers should obtain the latest relevant information before placing orders and should verify that such information is current and complete. All semiconductor products (also referred to herein as "components") are sold subject to TI's terms and conditions of sale supplied at the time of order acknowledgment.

TI warrants performance of its components to the specifications applicable at the time of sale, in accordance with the warranty in TI's terms and conditions of sale of semiconductor products. Testing and other quality control techniques are used to the extent TI deems necessary to support this warranty. Except where mandated by applicable law, testing of all parameters of each component is not necessarily performed.

TI assumes no liability for applications assistance or the design of Buyers' products. Buyers are responsible for their products and applications using TI components. To minimize the risks associated with Buyers' products and applications, Buyers should provide adequate design and operating safeguards.

TI does not warrant or represent that any license, either express or implied, is granted under any patent right, copyright, mask work right, or other intellectual property right relating to any combination, machine, or process in which TI components or services are used. Information published by TI regarding third-party products or services does not constitute a license to use such products or services or a warranty or endorsement thereof. Use of such information may require a license from a third party under the patents or other intellectual property of the third party, or a license from TI under the patents or other intellectual property of TI.

Reproduction of significant portions of TI information in TI data books or data sheets is permissible only if reproduction is without alteration and is accompanied by all associated warranties, conditions, limitations, and notices. TI is not responsible or liable for such altered documentation. Information of third parties may be subject to additional restrictions.

Resale of TI components or services with statements different from or beyond the parameters stated by TI for that component or service voids all express and any implied warranties for the associated TI component or service and is an unfair and deceptive business practice. TI is not responsible or liable for any such statements.

Buyer acknowledges and agrees that it is solely responsible for compliance with all legal, regulatory and safety-related requirements concerning its products, and any use of TI components in its applications, notwithstanding any applications-related information or support that may be provided by TI. Buyer represents and agrees that it has all the necessary expertise to create and implement safeguards which anticipate dangerous consequences of failures, monitor failures and their consequences, lessen the likelihood of failures that might cause harm and take appropriate remedial actions. Buyer will fully indemnify TI and its representatives against any damages arising out of the use of any TI components in safety-critical applications.

In some cases, TI components may be promoted specifically to facilitate safety-related applications. With such components, TI's goal is to help enable customers to design and create their own end-product solutions that meet applicable functional safety standards and requirements. Nonetheless, such components are subject to these terms.

No TI components are authorized for use in FDA Class III (or similar life-critical medical equipment) unless authorized officers of the parties have executed a special agreement specifically governing such use.

Only those TI components which TI has specifically designated as military grade or "enhanced plastic" are designed and intended for use in military/aerospace applications or environments. Buyer acknowledges and agrees that any military or aerospace use of TI components which have **not** been so designated is solely at the Buyer's risk, and that Buyer is solely responsible for compliance with all legal and regulatory requirements in connection with such use.

TI has specifically designated certain components as meeting ISO/TS16949 requirements, mainly for automotive use. In any case of use of non-designated products, TI will not be responsible for any failure to meet ISO/TS16949.

Products

Audio	www.ti.com/audio
Amplifiers	amplifier.ti.com
Data Converters	dataconverter.ti.com
DLP® Products	www.dlp.com
DSP	dsp.ti.com
Clocks and Timers	www.ti.com/clocks
Interface	interface.ti.com
Logic	logic.ti.com
Power Mgmt	power.ti.com
Microcontrollers	microcontroller.ti.com
RFID	www.ti-rfid.com
OMAP Applications Processors	www.ti.com/omap
Wireless Connectivity	www.ti.com/wirelessconnectivity

Applications

Automotive and Transportation	www.ti.com/automotive
Communications and Telecom	www.ti.com/communications
Computers and Peripherals	www.ti.com/computers
Consumer Electronics	www.ti.com/consumer-apps
Energy and Lighting	www.ti.com/energy
Industrial	www.ti.com/industrial
Medical	www.ti.com/medical
Security	www.ti.com/security
Space, Avionics and Defense	www.ti.com/space-avionics-defense
Video and Imaging	www.ti.com/video

TI E2E Community

e2e.ti.com