

SN54LVTH2245, SN74LVTH2245 3.3-V ABT OCTAL BUS TRANSCEIVERS WITH 3-STATE OUTPUTS

SCBS707E – SEPTEMBER 1997 – REVISED OCTOBER 2003

- Support Mixed-Mode Signal Operation (5-V Input and Output Voltages With 3.3-V V_{CC})
- Support Unregulated Battery Operation Down to 2.7 V
- Typical V_{OLP} (Output Ground Bounce) <0.8 V at $V_{CC} = 3.3$ V, $T_A = 25^\circ\text{C}$
- B-Port Outputs Have Equivalent 22- Ω Series Resistors, So No External Resistors Are Required
- I_{off} and Power-Up 3-State Support Hot Insertion
- Bus Hold on Data Inputs Eliminates the Need for External Pullup/Pulldown Resistors
- Latch-Up Performance Exceeds 500 mA Per JESD 17
- ESD Protection Exceeds JESD 22
 - 2000-V Human-Body Model (A114-A)
 - 200-V Machine Model (A115-A)

description/ordering information

These octal bus transceivers are designed specifically for low-voltage (3.3-V) V_{CC} operation, but with the capability to provide a TTL interface to a 5-V system environment.

These devices are designed for asynchronous communication between data buses. They transmit data from the A bus to the B bus or from the B bus to the A bus, depending on the logic level at the direction-control (DIR) input. The output-enable (\overline{OE}) input can be used to disable the devices so the buses are effectively isolated.

SN54LVTH2245 . . . J OR W PACKAGE
SN74LVTH2245 . . . DB, DGV, DW, NS, OR PW PACKAGE
(TOP VIEW)

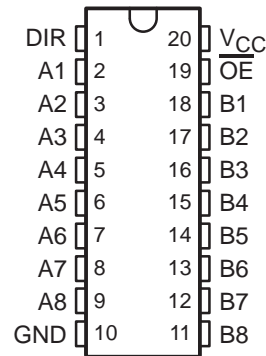

SN54LVTH2245 . . . FK PACKAGE
(TOP VIEW)

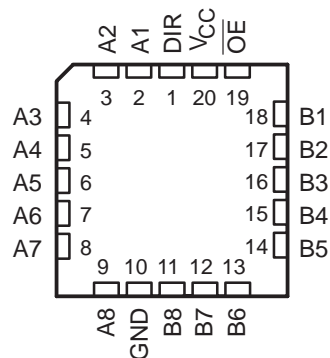

ORDERING INFORMATION

T_A	PACKAGE†		ORDERABLE PART NUMBER	TOP-SIDE MARKING
-40°C to 85°C	SOIC – DW	Tube	SN74LVTH2245DW	LVTH2245
		Tape and reel	SN74LVTH2245DWR	
	SOP – NS	Tape and reel	SN74LVTH2245NSR	LVTH2245
	SSOP – DB	Tape and reel	SN74LVTH2245DBR	LK245
	TSSOP – PW	Tube	SN74LVTH2245PW	LK245
		Tape and reel	SN74LVTH2245PWR	
	TVSOP – DGV	Tape and reel	SN74LVTH2245DGVR	LK245
-55°C to 125°C	CDIP – J	Tube	SNJ54LVTH2245J	SNJ54LVTH2245J
	CFP – W	Tube	SNJ54LVTH2245W	SNJ54LVTH2245W
	LCCC – FK	Tube	SNJ54LVTH2245FK	SNJ54LVTH2245FK

† Package drawings, standard packing quantities, thermal data, symbolization, and PCB design guidelines are available at www.ti.com/sc/package.



Please be aware that an important notice concerning availability, standard warranty, and use in critical applications of Texas Instruments semiconductor products and disclaimers thereto appears at the end of this data sheet.

UNLESS OTHERWISE NOTED this document contains PRODUCTION DATA information current as of publication date. Products conform to specifications per the terms of Texas Instruments standard warranty. Production processing does not necessarily include testing of all parameters.

 **TEXAS
INSTRUMENTS**

POST OFFICE BOX 655303 • DALLAS, TEXAS 75265

Copyright © 2003, Texas Instruments Incorporated

SN54LVTH2245, SN74LVTH2245

3.3-V ABT OCTAL BUS TRANSCEIVERS WITH 3-STATE OUTPUTS

SCBS707E – SEPTEMBER 1997 – REVISED OCTOBER 2003

description/ordering information (continued)

Active bus-hold circuitry is provided to hold unused or floating data inputs at a valid logic level. Use of pullup or pulldown resistors with the bus-hold circuitry is not recommended.

The B-port outputs, which are designed to source or sink up to 12 mA, include equivalent 22-Ω series resistors to reduce overshoot and undershoot.

When V_{CC} is between 0 and 1.5 V, the devices are in the high-impedance state during power up or power down. However, to ensure the high-impedance state above 1.5 V, \overline{OE} should be tied to V_{CC} through a pullup resistor; the minimum value of the resistor is determined by the current-sinking capability of the driver.

These devices are fully specified for hot-insertion applications using I_{off} and power-up 3-state. The I_{off} circuitry disables the outputs, preventing damaging current backflow through the devices when they are powered down. The power-up 3-state circuitry places the outputs in the high-impedance state during power up and power down, which prevents driver conflict.

FUNCTION TABLE

INPUTS		OPERATION
\overline{OE}	DIR	
L	L	B data to A bus
L	H	A data to B bus
H	X	Isolation

logic diagram (positive logic)

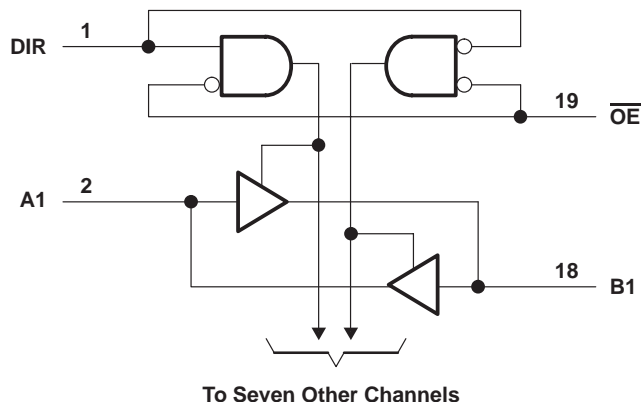

SN54LVTH2245, SN74LVTH2245 3.3-V ABT OCTAL BUS TRANSCEIVERS WITH 3-STATE OUTPUTS

SCBS707E – SEPTEMBER 1997 – REVISED OCTOBER 2003

absolute maximum ratings over operating free-air temperature range (unless otherwise noted)†

Supply voltage range, V_{CC}	–0.5 V to 4.6 V
Input voltage range, V_I (see Note 1)	–0.5 V to 7 V
Voltage range applied to any output in the high-impedance or power-off state, V_O (see Note 1)	–0.5 V to 7 V
Voltage range applied to any output in the high state, V_O (see Note 1)	–0.5 V to $V_{CC} + 0.5$ V
Current into any output in the low state, I_O : SN54LVTH2245 (A port)	96 mA
SN74LVTH2245 (A port)	128 mA
B port	30 mA
Current into any output in the high state, I_O (see Note 2): SN54LVTH2245 (A port)	48 mA
SN74LVTH2245 (A port)	64 mA
B port	30 mA
Input clamp current, I_{IK} ($V_I < 0$)	–50 mA
Output clamp current, I_{OK} ($V_O < 0$)	–50 mA
Package thermal impedance, θ_{JA} (see Note 3): DB package	70°C/W
DGV package	92°C/W
DW package	58°C/W
NS package	60°C/W
PW package	83°C/W
Storage temperature range, T_{stg}	–65°C to 150°C

† Stresses beyond those listed under “absolute maximum ratings” may cause permanent damage to the device. These are stress ratings only, and functional operation of the device at these or any other conditions beyond those indicated under “recommended operating conditions” is not implied. Exposure to absolute-maximum-rated conditions for extended periods may affect device reliability.

- NOTES: 1. The input and output negative-voltage ratings may be exceeded if the input and output clamp-current ratings are observed.
 2. This current flows only when the output is in the high state and $V_O > V_{CC}$.
 3. The package thermal impedance is calculated in accordance with JESD 51-7.

recommended operating conditions (see Note 4)

		SN54LVTH2245		SN74LVTH2245		UNIT
		MIN	MAX	MIN	MAX	
V_{CC}	Supply voltage	2.7	3.6	2.7	3.6	V
V_{IH}	High-level input voltage	2		2		V
V_{IL}	Low-level input voltage		0.8		0.8	V
V_I	Input voltage		5.5		5.5	V
I_{OH}	High-level output current	A port		–24		mA
		B port		–12		
I_{OL}	Low-level output current	A port		48		mA
		B port		12		
$\Delta t/\Delta v$	Input transition rise or fall rate		10		10	ns/V
$\Delta t/\Delta V_{CC}$	Power-up ramp rate	200		200		μs/V
T_A	Operating free-air temperature	–55	125	–40	85	°C

NOTE 4: All unused control inputs of the device must be held at V_{CC} or GND to ensure proper device operation. Refer to the TI application report, *Implications of Slow or Floating CMOS Inputs*, literature number SCBA004.

PRODUCT PREVIEW information concerns products in the formative or design phase of development. Characteristic data and other specifications are design goals. Texas Instruments reserves the right to change or discontinue these products without notice.



POST OFFICE BOX 655303 • DALLAS, TEXAS 75265

SN54LVTH2245, SN74LVTH2245

3.3-V ABT OCTAL BUS TRANSCEIVERS

WITH 3-STATE OUTPUTS

SCBS707E – SEPTEMBER 1997 – REVISED OCTOBER 2003

electrical characteristics over recommended operating free-air temperature range (unless otherwise noted)

PARAMETER		TEST CONDITIONS		SN54LVTH2245		SN74LVTH2245		UNIT	
				MIN	TYP†	MAX	MIN		TYP†
V _{IK}		V _{CC} = 2.7 V, I _I = -18 mA		-1.2		-1.2		V	
V _{OH}	A port	V _{CC} = 2.7 V to 3.6 V, I _{OH} = -100 μA		V _{CC} -0.2		V _{CC} -0.2		V	
		V _{CC} = 2.7 V, I _{OH} = -8 mA		2.4		2.4			
		V _{CC} = 3 V		2		2			
			I _{OH} = -24 mA						
		I _{OH} = -32 mA							
B port	V _{CC} = 2.7 V to 3.6 V, I _{OH} = -100 μA		V _{CC} -0.2		V _{CC} -0.2				
	V _{CC} = 3 V, I _{OH} = -12 mA		2		2				
V _{OL}	A port	V _{CC} = 2.7 V		I _{OL} = 100 μA		0.2		0.2	
				I _{OL} = 24 mA		0.5		0.5	
		V _{CC} = 3 V		I _{OL} = 16 mA		0.4		0.4	
				I _{OL} = 32 mA		0.5		0.5	
				I _{OL} = 48 mA		0.55			
			I _{OL} = 64 mA				0.55		
	B port	V _{CC} = 2.7 V to 3.6 V, I _{OL} = 100 μA				0.2		0.2	
		V _{CC} = 3 V, I _{OL} = 12 mA				0.8		0.8	
I _I	Control inputs	V _{CC} = 3.6 V, V _I = V _{CC} or GND		±1		±1		μA	
		V _{CC} = 0 or 3.6 V, V _I = 5.5 V		10		10			
	A or B ports‡	V _{CC} = 3.6 V		V _I = 5.5 V		20			20
				V _I = V _{CC}		1			1
				V _I = 0		-5		-5	
I _{off}		V _{CC} = 0, V _I or V _O = 0 to 4.5 V				±100		μA	
I _I (hold)	A or B ports	V _{CC} = 3 V		V _I = 0.8 V		75		μA	
				V _I = 2 V		-75			
		V _{CC} = 3.6 V§, V _I = 0 to 3.6 V				500			-750
I _{OZPU}		V _{CC} = 0 to 1.5 V, V _O = 0.5 V to 3 V, OE = don't care		±100*		±100		μA	
I _{OZPD}		V _{CC} = 1.5 V to 0, V _O = 0.5 V to 3 V, OE = don't care		±100*		±100		μA	
I _{CC}	V _{CC} = 3.6 V, I _O = 0, V _I = V _{CC} or GND		Outputs high		0.19		0.1 0.19		mA
			Outputs low		5		3 5		
			Outputs disabled		0.19		0.1 0.19		
ΔI _{CC} ¶		V _{CC} = 3 V to 3.6 V, One input at V _{CC} - 0.6 V, Other inputs at V _{CC} or GND		0.2		0.2		mA	
C _i		V _I = 3 V or 0		4		4		pF	
C _{io}		V _O = 3 V or 0		9		9		pF	

* On products compliant to MIL-PRF-38535, this parameter is not production tested.

† All typical values are at V_{CC} = 3.3 V, T_A = 25°C.

‡ Unused terminals are at V_{CC} or GND.

§ This is the bus-hold maximum dynamic current. It is the minimum overdrive current required to switch the input from one state to another.

¶ This is the increase in supply current for each input that is at the specified TTL voltage level, rather than V_{CC} or GND.

PRODUCT PREVIEW information concerns products in the formative or design phase of development. Characteristic data and other specifications are design goals. Texas Instruments reserves the right to change or discontinue these products without notice.



POST OFFICE BOX 655303 • DALLAS, TEXAS 75265

SN54LVTH2245, SN74LVTH2245 3.3-V ABT OCTAL BUS TRANSCEIVERS WITH 3-STATE OUTPUTS

SCBS707E – SEPTEMBER 1997 – REVISED OCTOBER 2003

switching characteristics over recommended operating free-air temperature range, $C_L = 50$ pF (unless otherwise noted) (see Figure 1)

PARAMETER	FROM (INPUT)	TO (OUTPUT)	SN54LVTH2245				SN74LVTH2245				UNIT	
			$V_{CC} = 3.3$ V ± 0.3 V		$V_{CC} = 2.7$ V		$V_{CC} = 3.3$ V ± 0.3 V			$V_{CC} = 2.7$ V		
			MIN	MAX	MIN	MAX	MIN	TYP†	MAX	MIN		MAX
t_{PLH}	A	B	1	4.6	5.3		1.1	2.9	4.4	5.1		ns
t_{PHL}			1	4.6	5.3		1.1	2.6	4.4	5.1		
t_{PLH}	B	A	1	3.7	4.2		1.1	2.2	3.5	4		ns
t_{PHL}			1	3.7	4.2		1.1	2	3.5	4		
t_{PZH}	\overline{OE}	A	1.2	5.7	7.4		1.3	3.1	5.5	7.1		ns
t_{PZL}			1.6	5.7	6.8		1.7	3.2	5.5	6.5		
t_{PHZ}	\overline{OE}	A	2	6.2	6.8		2.2	3.6	5.9	6.5		ns
t_{PLZ}			2	5.3	5.5		2.2	3.4	5	5.1		
t_{PZH}	\overline{OE}	B	1.2	6.4	7.6		1.3	3.5	6.2	7.3		ns
t_{PZL}			1.6	6.4	7.5		1.7	3.7	6.2	7.3		
t_{PHZ}	\overline{OE}	B	2	6.1	6.8		2.2	3.9	5.9	6.5		ns
t_{PLZ}			2	5.7	5.9		2.2	3.7	5.4	5.7		

† All typical values are at $V_{CC} = 3.3$ V, $T_A = 25^\circ\text{C}$.

SN54LVTH2245, SN74LVTH2245 3.3-V ABT OCTAL BUS TRANSCEIVERS WITH 3-STATE OUTPUTS

SCBS707E – SEPTEMBER 1997 – REVISED OCTOBER 2003

PARAMETER MEASUREMENT INFORMATION

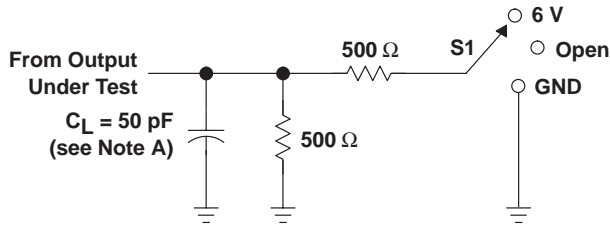

LOAD CIRCUIT

TEST	S1
t_{PLH}/t_{PHL}	Open
t_{PLZ}/t_{PZL}	6 V
t_{PHZ}/t_{PZH}	GND

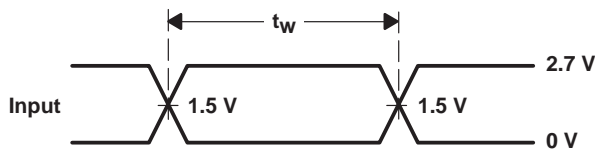

VOLTAGE WAVEFORMS
PULSE DURATION

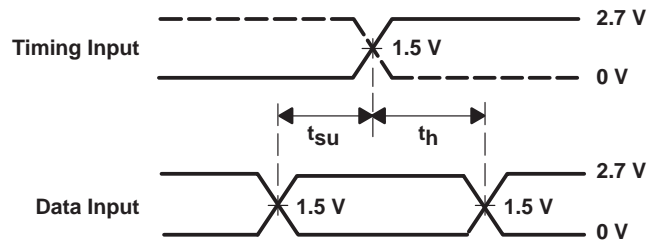

VOLTAGE WAVEFORMS
SETUP AND HOLD TIMES

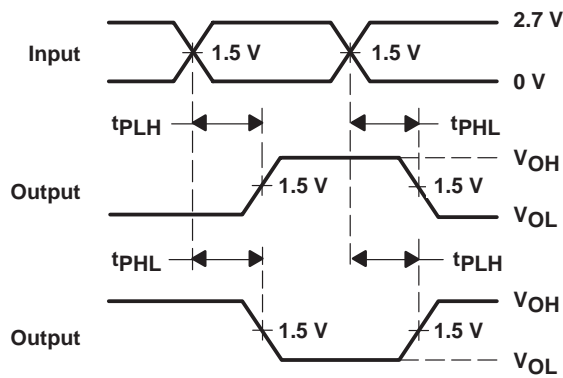

VOLTAGE WAVEFORMS
PROPAGATION DELAY TIMES
INVERTING AND NONINVERTING OUTPUTS

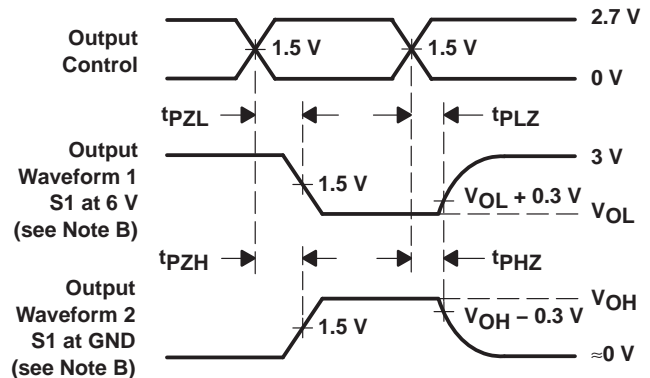

VOLTAGE WAVEFORMS
ENABLE AND DISABLE TIMES
LOW- AND HIGH-LEVEL ENABLING

- NOTES: A. C_L includes probe and jig capacitance.
 B. Waveform 1 is for an output with internal conditions such that the output is low except when disabled by the output control. Waveform 2 is for an output with internal conditions such that the output is high except when disabled by the output control.
 C. All input pulses are supplied by generators having the following characteristics: $PRR \leq 10 \text{ MHz}$, $Z_O = 50 \Omega$, $t_r \leq 2.5 \text{ ns}$, $t_f \leq 2.5 \text{ ns}$.
 D. The outputs are measured one at a time with one transition per measurement.
 E. All parameters and waveforms are not applicable to all devices.

Figure 1. Load Circuit and Voltage Waveforms

PACKAGING INFORMATION

Orderable Device	Status (1)	Package Type	Package Drawing	Pins	Package Qty	Eco Plan (2)	Lead/Ball Finish (6)	MSL Peak Temp (3)	Op Temp (°C)	Device Marking (4/5)	Samples
SN74LVTH2245DBLE	OBSOLETE	SSOP	DB	20		TBD	Call TI	Call TI	-40 to 85		
SN74LVTH2245DBR	ACTIVE	SSOP	DB	20	2000	Green (RoHS & no Sb/Br)	CU NIPDAU	Level-1-260C-UNLIM	-40 to 85	LK245	Samples
SN74LVTH2245DGVR	ACTIVE	TVSOP	DGV	20	2000	Green (RoHS & no Sb/Br)	CU NIPDAU	Level-1-260C-UNLIM	-40 to 85	LK245	Samples
SN74LVTH2245DW	ACTIVE	SOIC	DW	20	25	Green (RoHS & no Sb/Br)	CU NIPDAU	Level-1-260C-UNLIM	-40 to 85	LVTH2245	Samples
SN74LVTH2245DWE4	ACTIVE	SOIC	DW	20	25	Green (RoHS & no Sb/Br)	CU NIPDAU	Level-1-260C-UNLIM	-40 to 85	LVTH2245	Samples
SN74LVTH2245DWR	ACTIVE	SOIC	DW	20	2000	Green (RoHS & no Sb/Br)	CU NIPDAU	Level-1-260C-UNLIM	-40 to 85	LVTH2245	Samples
SN74LVTH2245DWRE4	ACTIVE	SOIC	DW	20	2000	Green (RoHS & no Sb/Br)	CU NIPDAU	Level-1-260C-UNLIM	-40 to 85	LVTH2245	Samples
SN74LVTH2245PW	ACTIVE	TSSOP	PW	20	70	Green (RoHS & no Sb/Br)	CU NIPDAU	Level-1-260C-UNLIM	-40 to 85	LK245	Samples
SN74LVTH2245PWG4	ACTIVE	TSSOP	PW	20	70	Green (RoHS & no Sb/Br)	CU NIPDAU	Level-1-260C-UNLIM	-40 to 85	LK245	Samples
SN74LVTH2245PWLE	OBSOLETE	TSSOP	PW	20		TBD	Call TI	Call TI	-40 to 85		
SN74LVTH2245PWR	ACTIVE	TSSOP	PW	20	2000	Green (RoHS & no Sb/Br)	CU NIPDAU	Level-1-260C-UNLIM	-40 to 85	LK245	Samples
SN74LVTH2245PWRG4	ACTIVE	TSSOP	PW	20	2000	Green (RoHS & no Sb/Br)	CU NIPDAU	Level-1-260C-UNLIM	-40 to 85	LK245	Samples

(1) The marketing status values are defined as follows:

ACTIVE: Product device recommended for new designs.

LIFEBUY: TI has announced that the device will be discontinued, and a lifetime-buy period is in effect.

NRND: Not recommended for new designs. Device is in production to support existing customers, but TI does not recommend using this part in a new design.

PREVIEW: Device has been announced but is not in production. Samples may or may not be available.

OBSOLETE: TI has discontinued the production of the device.

(2) Eco Plan - The planned eco-friendly classification: Pb-Free (RoHS), Pb-Free (RoHS Exempt), or Green (RoHS & no Sb/Br) - please check <http://www.ti.com/productcontent> for the latest availability information and additional product content details.

TBD: The Pb-Free/Green conversion plan has not been defined.

Pb-Free (RoHS): TI's terms "Lead-Free" or "Pb-Free" mean semiconductor products that are compatible with the current RoHS requirements for all 6 substances, including the requirement that lead not exceed 0.1% by weight in homogeneous materials. Where designed to be soldered at high temperatures, TI Pb-Free products are suitable for use in specified lead-free processes.

Pb-Free (RoHS Exempt): This component has a RoHS exemption for either 1) lead-based flip-chip solder bumps used between the die and package, or 2) lead-based die adhesive used between the die and leadframe. The component is otherwise considered Pb-Free (RoHS compatible) as defined above.

Green (RoHS & no Sb/Br): TI defines "Green" to mean Pb-Free (RoHS compatible), and free of Bromine (Br) and Antimony (Sb) based flame retardants (Br or Sb do not exceed 0.1% by weight in homogeneous material)

⁽³⁾ MSL, Peak Temp. - The Moisture Sensitivity Level rating according to the JEDEC industry standard classifications, and peak solder temperature.

⁽⁴⁾ There may be additional marking, which relates to the logo, the lot trace code information, or the environmental category on the device.

⁽⁵⁾ Multiple Device Markings will be inside parentheses. Only one Device Marking contained in parentheses and separated by a "~" will appear on a device. If a line is indented then it is a continuation of the previous line and the two combined represent the entire Device Marking for that device.

⁽⁶⁾ Lead/Ball Finish - Orderable Devices may have multiple material finish options. Finish options are separated by a vertical ruled line. Lead/Ball Finish values may wrap to two lines if the finish value exceeds the maximum column width.

Important Information and Disclaimer: The information provided on this page represents TI's knowledge and belief as of the date that it is provided. TI bases its knowledge and belief on information provided by third parties, and makes no representation or warranty as to the accuracy of such information. Efforts are underway to better integrate information from third parties. TI has taken and continues to take reasonable steps to provide representative and accurate information but may not have conducted destructive testing or chemical analysis on incoming materials and chemicals. TI and TI suppliers consider certain information to be proprietary, and thus CAS numbers and other limited information may not be available for release.

In no event shall TI's liability arising out of such information exceed the total purchase price of the TI part(s) at issue in this document sold by TI to Customer on an annual basis.

TAPE AND REEL INFORMATION

QUADRANT ASSIGNMENTS FOR PIN 1 ORIENTATION IN TAPE

*All dimensions are nominal

Device	Package Type	Package Drawing	Pins	SPQ	Reel Diameter (mm)	Reel Width W1 (mm)	A0 (mm)	B0 (mm)	K0 (mm)	P1 (mm)	W (mm)	Pin1 Quadrant
SN74LVTH2245DBR	SSOP	DB	20	2000	330.0	16.4	8.2	7.5	2.5	12.0	16.0	Q1
SN74LVTH2245DGVR	TVSOP	DGV	20	2000	330.0	12.4	6.9	5.6	1.6	8.0	12.0	Q1
SN74LVTH2245DWR	SOIC	DW	20	2000	330.0	24.4	10.8	13.0	2.7	12.0	24.0	Q1
SN74LVTH2245PWR	TSSOP	PW	20	2000	330.0	16.4	6.95	7.1	1.6	8.0	16.0	Q1

TAPE AND REEL BOX DIMENSIONS

*All dimensions are nominal

Device	Package Type	Package Drawing	Pins	SPQ	Length (mm)	Width (mm)	Height (mm)
SN74LVTH2245DBR	SSOP	DB	20	2000	367.0	367.0	38.0
SN74LVTH2245DGVR	TVSOP	DGV	20	2000	367.0	367.0	35.0
SN74LVTH2245DWR	SOIC	DW	20	2000	367.0	367.0	45.0
SN74LVTH2245PWR	TSSOP	PW	20	2000	367.0	367.0	38.0

DGV (R-PDSO-G**)

PLASTIC SMALL-OUTLINE

24 PINS SHOWN



- NOTES: A. All linear dimensions are in millimeters.
 B. This drawing is subject to change without notice.
 C. Body dimensions do not include mold flash or protrusion, not to exceed 0,15 per side.
 D. Falls within JEDEC: 24/48 Pins – MO-153
 14/16/20/56 Pins – MO-194

DW (R-PDSO-G20)

PLASTIC SMALL OUTLINE

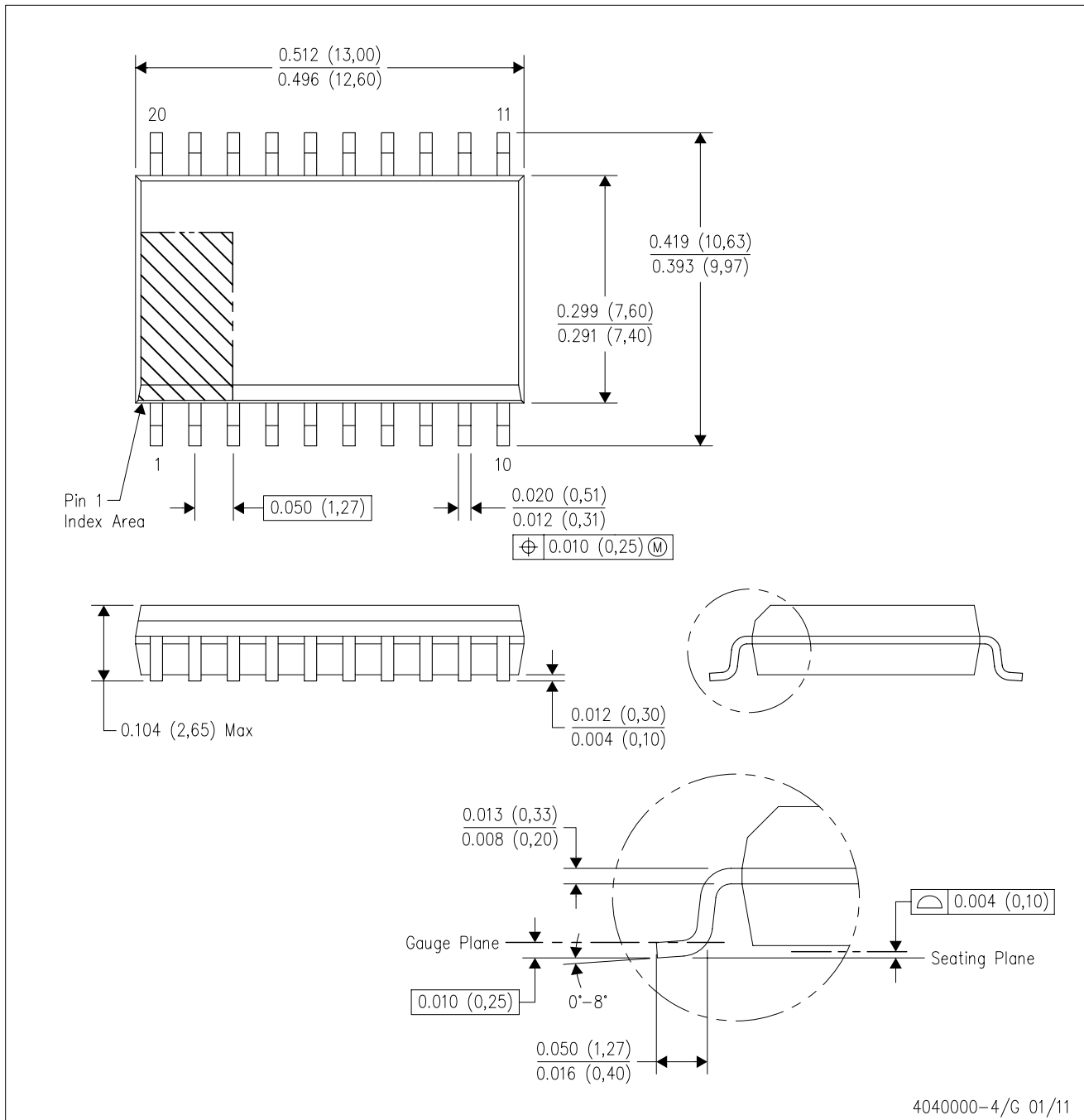

- NOTES:
- A. All linear dimensions are in inches (millimeters). Dimensioning and tolerancing per ASME Y14.5M-1994.
 - B. This drawing is subject to change without notice.
 - C. Body dimensions do not include mold flash or protrusion not to exceed 0.006 (0,15).
 - D. Falls within JEDEC MS-013 variation AC.

PW (R-PDSO-G20)

PLASTIC SMALL OUTLINE



4040064-5/G 02/11

- NOTES:
- A. All linear dimensions are in millimeters. Dimensioning and tolerancing per ASME Y14.5M-1994.
 - B. This drawing is subject to change without notice.
 - C. Body length does not include mold flash, protrusions, or gate burrs. Mold flash, protrusions, or gate burrs shall not exceed 0,15 each side.
 - D. Body width does not include interlead flash. Interlead flash shall not exceed 0,25 each side.
 - E. Falls within JEDEC MO-153

PW (R-PDSO-G20)

PLASTIC SMALL OUTLINE



- NOTES:
- A. All linear dimensions are in millimeters.
 - B. This drawing is subject to change without notice.
 - C. Publication IPC-7351 is recommended for alternate design.
 - D. Laser cutting apertures with trapezoidal walls and also rounding corners will offer better paste release. Customers should contact their board assembly site for stencil design recommendations. Refer to IPC-7525 for other stencil recommendations.
 - E. Customers should contact their board fabrication site for solder mask tolerances between and around signal pads.

DB (R-PDSO-G**)

PLASTIC SMALL-OUTLINE

28 PINS SHOWN



- NOTES: A. All linear dimensions are in millimeters.
 B. This drawing is subject to change without notice.
 C. Body dimensions do not include mold flash or protrusion not to exceed 0,15.
 D. Falls within JEDEC MO-150

IMPORTANT NOTICE

Texas Instruments Incorporated and its subsidiaries (TI) reserve the right to make corrections, enhancements, improvements and other changes to its semiconductor products and services per JESD46, latest issue, and to discontinue any product or service per JESD48, latest issue. Buyers should obtain the latest relevant information before placing orders and should verify that such information is current and complete. All semiconductor products (also referred to herein as "components") are sold subject to TI's terms and conditions of sale supplied at the time of order acknowledgment.

TI warrants performance of its components to the specifications applicable at the time of sale, in accordance with the warranty in TI's terms and conditions of sale of semiconductor products. Testing and other quality control techniques are used to the extent TI deems necessary to support this warranty. Except where mandated by applicable law, testing of all parameters of each component is not necessarily performed.

TI assumes no liability for applications assistance or the design of Buyers' products. Buyers are responsible for their products and applications using TI components. To minimize the risks associated with Buyers' products and applications, Buyers should provide adequate design and operating safeguards.

TI does not warrant or represent that any license, either express or implied, is granted under any patent right, copyright, mask work right, or other intellectual property right relating to any combination, machine, or process in which TI components or services are used. Information published by TI regarding third-party products or services does not constitute a license to use such products or services or a warranty or endorsement thereof. Use of such information may require a license from a third party under the patents or other intellectual property of the third party, or a license from TI under the patents or other intellectual property of TI.

Reproduction of significant portions of TI information in TI data books or data sheets is permissible only if reproduction is without alteration and is accompanied by all associated warranties, conditions, limitations, and notices. TI is not responsible or liable for such altered documentation. Information of third parties may be subject to additional restrictions.

Resale of TI components or services with statements different from or beyond the parameters stated by TI for that component or service voids all express and any implied warranties for the associated TI component or service and is an unfair and deceptive business practice. TI is not responsible or liable for any such statements.

Buyer acknowledges and agrees that it is solely responsible for compliance with all legal, regulatory and safety-related requirements concerning its products, and any use of TI components in its applications, notwithstanding any applications-related information or support that may be provided by TI. Buyer represents and agrees that it has all the necessary expertise to create and implement safeguards which anticipate dangerous consequences of failures, monitor failures and their consequences, lessen the likelihood of failures that might cause harm and take appropriate remedial actions. Buyer will fully indemnify TI and its representatives against any damages arising out of the use of any TI components in safety-critical applications.

In some cases, TI components may be promoted specifically to facilitate safety-related applications. With such components, TI's goal is to help enable customers to design and create their own end-product solutions that meet applicable functional safety standards and requirements. Nonetheless, such components are subject to these terms.

No TI components are authorized for use in FDA Class III (or similar life-critical medical equipment) unless authorized officers of the parties have executed a special agreement specifically governing such use.

Only those TI components which TI has specifically designated as military grade or "enhanced plastic" are designed and intended for use in military/aerospace applications or environments. Buyer acknowledges and agrees that any military or aerospace use of TI components which have **not** been so designated is solely at the Buyer's risk, and that Buyer is solely responsible for compliance with all legal and regulatory requirements in connection with such use.

TI has specifically designated certain components as meeting ISO/TS16949 requirements, mainly for automotive use. In any case of use of non-designated products, TI will not be responsible for any failure to meet ISO/TS16949.

Products

Audio	www.ti.com/audio
Amplifiers	amplifier.ti.com
Data Converters	dataconverter.ti.com
DLP® Products	www.dlp.com
DSP	dsp.ti.com
Clocks and Timers	www.ti.com/clocks
Interface	interface.ti.com
Logic	logic.ti.com
Power Mgmt	power.ti.com
Microcontrollers	microcontroller.ti.com
RFID	www.ti-rfid.com
OMAP Applications Processors	www.ti.com/omap
Wireless Connectivity	www.ti.com/wirelessconnectivity

Applications

Automotive and Transportation	www.ti.com/automotive
Communications and Telecom	www.ti.com/communications
Computers and Peripherals	www.ti.com/computers
Consumer Electronics	www.ti.com/consumer-apps
Energy and Lighting	www.ti.com/energy
Industrial	www.ti.com/industrial
Medical	www.ti.com/medical
Security	www.ti.com/security
Space, Avionics and Defense	www.ti.com/space-avionics-defense
Video and Imaging	www.ti.com/video

TI E2E Community

e2e.ti.com