

SN75ALS085

LAN ACCESS UNIT INTERFACE DUAL DRIVER/RECEIVER

SLLS054D – APRIL 1989 – REVISED OCTOBER 2001

- Meets or Exceeds the Requirements of IOS 8802.3:1989 and ANSI/IEEE Std 802.3-1988
- Interdevice Loopback Paths for System Testing
- Squelch Function Implemented on the Receiver Inputs
- Drives a Balanced 78-Ω Load
- Transformer Coupling Not Required in System
- Power-Up/Power-Down Protection (Glitch Free)
- Isolated Ground Pins for Reduced Noise Coupling
- Fault-Condition Protection Built Into the Device
- Driver Inputs Are Level-Shifted ECL Compatible
- Package Options Include Plastic Small-Outline (DW) Package and Standard Plastic (NT) DIP

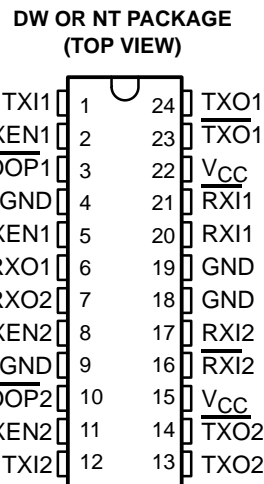

description

The SN75ALS085 is a high-speed, advanced low-power Schottky, dual-channel driver/receiver device designed for use in the AUI of ANSI/IEEE Std 802.3-1988. The two drivers on the device drive a 78-Ω balanced, terminated twisted-pair transmission line up to a maximum length of 50 meters. In the off (idle) state, the drivers maintain minimal differential output voltage on the twisted-pair line and, at the same time, remain within the required output common-mode range.

With the driver enable (TXEN) high, upon receiving the first falling edge into the driver input, the differential outputs rise to full-amplitude output levels within 25 ns. The output amplitude is maintained for the remainder of the packet. After the last positive packet edge is transmitted into the driver, the driver maintains a minimum of 70% full differential output for a minimum of 200 ns, then decays to a minimum level for the reset (idle) condition within 8 μs. Disabling the driver by taking the driver enable low also forces the output into the idle condition after the normal 8-μs timeout. While operating, the drivers are able to withstand a set of fault conditions and not suffer damage due to the faults being applied. The drivers power up in the idle state to ensure that no activity is placed on the twisted-pair cable, which could be interpreted as network traffic.

The line receiver squelch function interfaces to a differential twisted-pair line terminated external to the device. The receiver squelch circuit allows differential receive signals to pass through, as long as the input amplitude and pulse duration are greater than the minimum squelch threshold. This ensures a good signal-to-noise ratio while the data path is active and prevents system noise from causing false data transitions during line shutdown and line-idle conditions. The receiver outputs (RXO) default to a high level and the receiver-enable (RXEN) outputs default to a low level while the squelch function is blocking the data path through the receiver (idle). The line receiver squelch becomes active within 50 ns when the input squelch threshold is exceeded. RXEN is driven high when the squelch circuit allows data to pass through the receiver. The receiver squelch circuit also can withstand a set of fault conditions while operating, without causing permanent damage to the device.



Please be aware that an important notice concerning availability, standard warranty, and use in critical applications of Texas Instruments semiconductor products and disclaimers thereto appears at the end of this data sheet.

PRODUCTION DATA information is current as of publication date. Products conform to specifications per the terms of Texas Instruments standard warranty. Production processing does not necessarily include testing of all parameters.

**TEXAS
INSTRUMENTS**

POST OFFICE BOX 655303 • DALLAS, TEXAS 75265

Copyright © 2001, Texas Instruments Incorporated

SN75ALS085 LAN ACCESS UNIT INTERFACE DUAL DRIVER/RECEIVER

SLLS054D – APRIL 1989 – REVISED OCTOBER 2001

description (continued)

The purpose of the loop functions is to provide a means by which system data-path verification can be done to isolate faulty interfaces and assist in network diagnosis. The LOOP pins are TTL compatible and must be held high for normal operation. When $\overline{\text{LOOP}}1$ is taken low, the output of driver 1 (TXO1) immediately goes into the idle state. Also, the input to receiver 1 is ignored, and a path from a transmit input (TXI1) to RXO1 is established. When $\overline{\text{LOOP}}1$ is taken back high, driver 1 and receiver 1 revert back to their normal operation. When $\overline{\text{LOOP}}2$ is taken low, a similar data path is established between TXI1 and RXO2. TXEN1 must be high for the loop functions to operate, and TXEN1 can be used to gate the loop function if desired. During loop operation, the respective RXEN reflects the status of TXEN1.

The SN75ALS085 is characterized for operation from 0°C to 70°C.

AVAILABLE OPTIONS

T _A	PACKAGED DEVICES	
	PLASTIC SMALL OUTLINE (DW)	PLASTIC DIP (NT)
0°C to 70°C	SN75ALS085DW	SN75ALS085NT

The DW package is available taped and reeled. Add the suffix R to device type (e.g., SN75ALS085DWR).

Function Tables

RECEIVER ($\overline{\text{LOOP}} = \text{H}$)

RXI	PREVIOUS RXEN	OUTPUTS	
		RXEN	RXO
V _{ID} = 1315 mV to -175 mV, t _w < 25 ns	L	L	H
V _{ID} = -275 mV to -1315 mV, t _w > 50 ns	X	H	L
V _{ID} = 318 mV to 1315 mV, t _w < 142 ns	H	H	H
V _{ID} = 318 mV to 1315 mV, t _w > 187 ns	X	L	H

H = high level, L = low level, X = don't care

DRIVER ($\overline{\text{LOOP}} = \text{H}$)

TXI	TXEN	PREVIOUS TXO	OUTPUT TXO
L	L	Idle	Idle
H	L	Idle	Idle
↓	H	Idle	L
L	H	Active	L
H < 260 μs	H	Active	H
H > 8 μs	H	Active	Idle
L	L > 8 μs	Active	Idle
H < 260 ns	L > 8 μs	Active	Idle
H < 260 ns	L < 260 ns	Active	H
H > 8 μs	L < 260 ns	Active	Idle
L	L < 260 ns	Active	L

H = V_I ≥ V_T max, L = V_I ≤ V_T min



SN75ALS085

LAN ACCESS UNIT INTERFACE DUAL DRIVER/RECEIVER

SLLS054D – APRIL 1989 – REVISED OCTOBER 2001

Function Tables (continued)

LOOP										
INPUTS						OUTPUTS				
LOOP1	LOOP2	TXI1	TXEN1	RXI1	RXI2	RXO1	RXO2	RXEN1	RXEN2	TXO1
L	L	L	H	X	X	L	L	H	H	Idle
L	L	H	H	X	X	H	H	H	H	Idle
L	L	X	L	X	X	H	H	L	L	Idle
L	H	L	H	X	Normal	L	Normal	H	Normal	Idle
L	H	H	H	X	Normal	H	Normal	H	Normal	Idle
L	H	X	L	X	Normal	H	Normal	L	Normal	Idle
H	L	L	H	Normal	X	Normal	L	Normal	H	Idle
H	L	H	H	Normal	X	Normal	H	Normal	H	Idle
H	L	X	L	Normal	X	Normal	H	Normal	L	Idle
H	H	Normal	Normal	Normal	Normal	Normal	Normal	Normal	Normal	Normal

H = high level, L = low level, X = don't care



SN75ALS085 LAN ACCESS UNIT INTERFACE DUAL DRIVER/RECEIVER

SLLS054D – APRIL 1989 – REVISED OCTOBER 2001

logic diagram (positive logic)

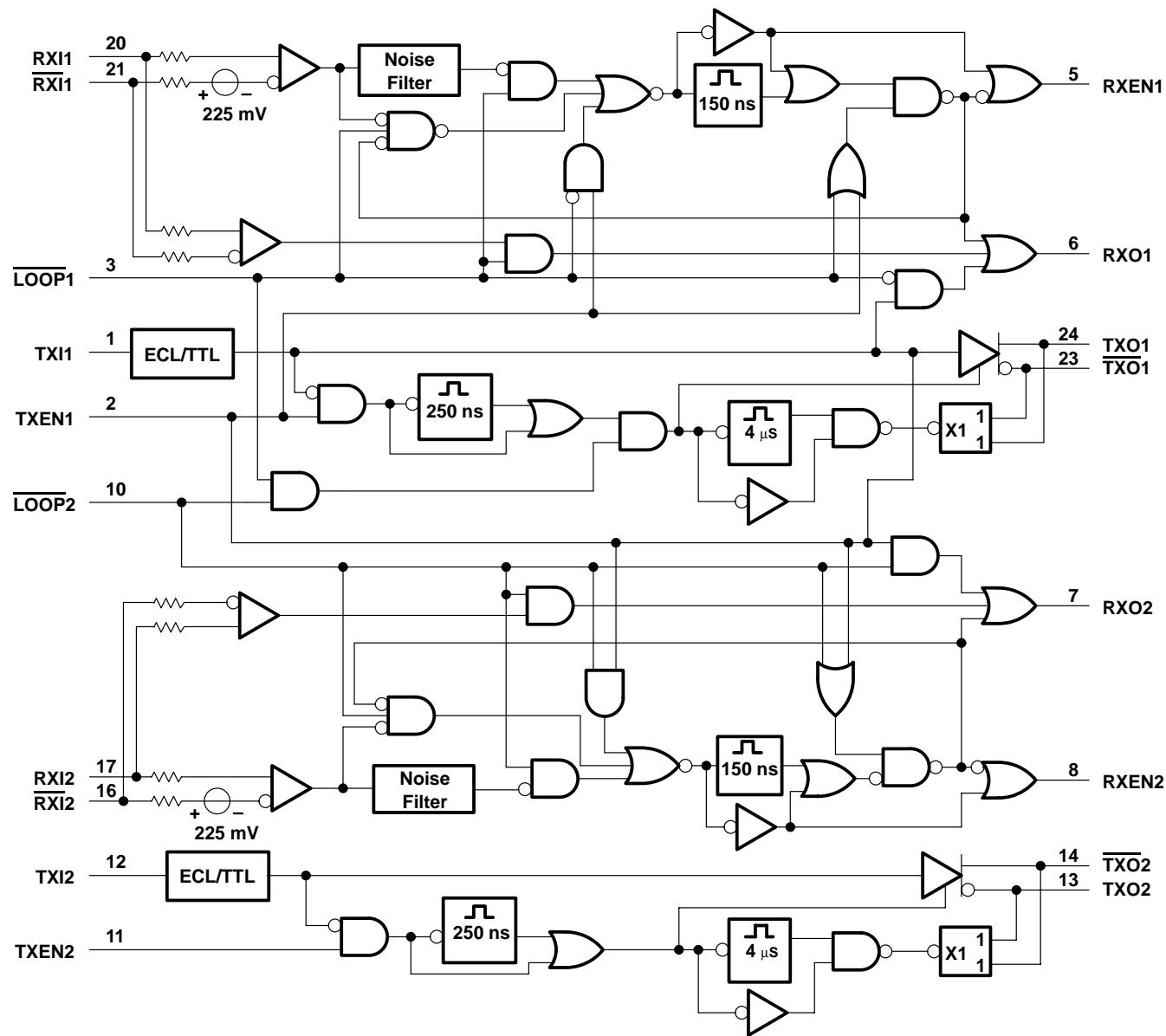

schematics of inputs and outputs

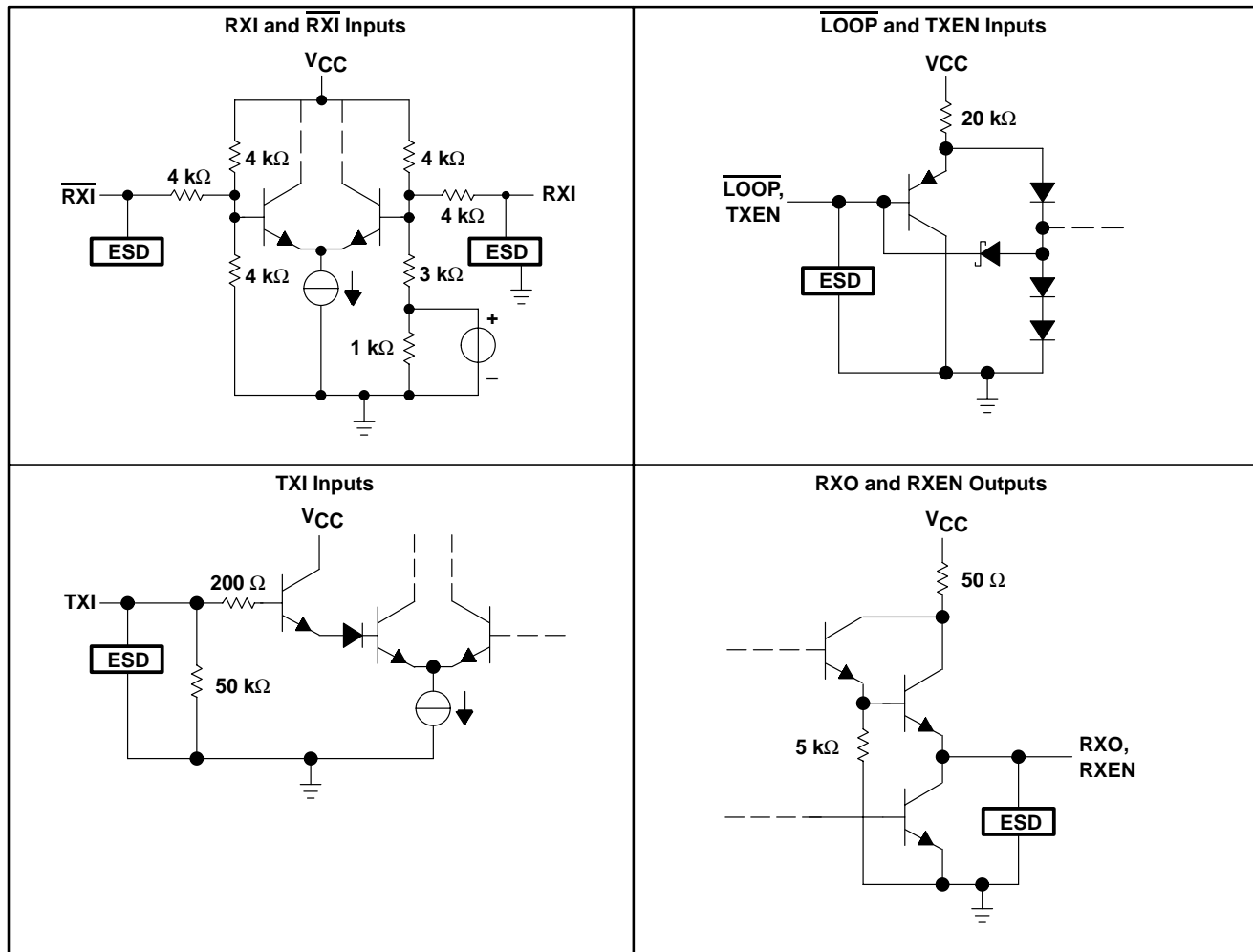

SN75ALS085

LAN ACCESS UNIT INTERFACE DUAL DRIVER/RECEIVER

SLLS054D – APRIL 1989 – REVISED OCTOBER 2001

absolute maximum ratings over operating free-air temperature range (unless otherwise noted)†

Supply voltage, V_{CC} (see Note 1)	6 V
TXI and \overline{LOOP} input voltage, V_I	5.5 V
TXO and \overline{TXO} output voltage, V_O	16 V
RXI and \overline{RXI} input voltage, V_I	16 V
RXO and RXEN output voltage, V_O	5.5 V
Package thermal impedance, θ_{JA} (see Notes 2 and 3): DW package	46°C/W
(see Notes 2 and 4): NT package	67°C/W
Lead temperature 1,6 mm (1/16 inch) from case for 10 seconds	260°C
Storage temperature range, T_{stg}	-65 to 150°C

† Stresses beyond those listed under “absolute maximum ratings” may cause permanent damage to the device. These are stress ratings only, and functional operation of the device at these or any other conditions beyond those indicated under “recommended operating conditions” is not implied. Exposure to absolute-maximum-rated conditions for extended periods may affect device reliability.

- NOTES:
1. Voltage values are with respect to network ground terminal.
 2. Maximum power dissipation is a function of $T_J(\max)$, θ_{JA} , and T_A . The maximum allowable power dissipation at any allowable ambient temperature is $P_D = (T_J(\max) - T_A)/\theta_{JA}$. Operating at the absolute maximum T_J of 150°C can affect reliability.
 3. The package thermal impedance is calculated in accordance with JESD 51-7.
 4. The package thermal impedance is calculated in accordance with JESD 51-3.

recommended operating conditions

	MIN	NOM	MAX	UNIT
V_{CC} Supply voltage	4.75	5	5.25	V
V_{IC} Common-mode voltage at RXI inputs	1		4.2	V
V_{ID} Differential voltage between RXI inputs	±318		±1315	mV
V_{IH} High-level input voltage, \overline{LOOP} and TXEN	2			V
V_{IL} Low-level input voltage, \overline{LOOP} and TXEN			0.8	V
I_{OH} High-level output current, RXO and RXEN			-0.4	mA
I_{OL} Low-level output voltage, RXO and RXEN			16	mA
t_{su1} Setup time, driver mode, TXEN high before TXI↓ (see Figure 7)	10			ns
t_{su2} Setup time, loop mode, \overline{LOOP} low before TXEN↑ (see Figure 9)	15			ns
t_{su3} Setup time, loop mode, TXEN high before TXI↓ (see Figure 9)	10			ns
t_{h1} Hold time, loop mode, TXEN high after TXI↑ (see Figure 8)	10			ns
t_{h2} Hold time, loop mode, \overline{LOOP} low after TXEN↓ (see Figure 8)	15			ns
T_A Operating free-air temperature	0		70	°C



SN75ALS085

LAN ACCESS UNIT INTERFACE DUAL DRIVER/RECEIVER

SLLS054D – APRIL 1989 – REVISED OCTOBER 2001

electrical characteristics over recommended ranges of supply voltage and operating free-air temperature (unless otherwise noted)

PARAMETER		TEST CONDITIONS		MIN	MAX	UNIT	
V_{IK}	Clamp voltage at all inputs	$I_I = -18 \text{ mA}$			-1.5	V	
$V_{(TO)}$	Driver input (TXI) threshold voltage	$T_A = 0^\circ\text{C}$	$V_{CC} = 4.75 \text{ V}$	3.202	3.752	V	
			$V_{CC} = 5 \text{ V}$	3.389	3.998		
			$V_{CC} = 5.25 \text{ V}$	3.577	4.244		
		$T_A = 25^\circ\text{C}$	$V_{CC} = 4.75 \text{ V}$	3.213	3.797		
			$V_{CC} = 5 \text{ V}$	3.400	4.043		
			$V_{CC} = 5.25 \text{ V}$	3.588	4.289		
		$T_A = 70^\circ\text{C}$	$V_{CC} = 4.75 \text{ V}$	3.239	3.849		
			$V_{CC} = 5 \text{ V}$	3.426	4.095		
			$V_{CC} = 5.25 \text{ V}$	3.614	4.341		
Receiver differential input threshold voltage					-275	mV	
V_{OC}	Driver output (TXO) common-mode voltage	Idle	TXEN at 0.8 V, LOOP2 at 2 V, See Figure 1	LOOP1 at 2 V, See Figure 1	1	4.2	V
		Active	TXEN at 2 V, LOOP2 at 2 V, See Figure 1	LOOP1 at 2 V, TXI at 3.2 V, See Figure 1	1	4.2	
		Active	TXEN at 2 V, LOOP2 at 2 V, See Figure 1	LOOP1 at 2 V, TXI at 4.4 V, See Figure 1	1	4.2	
V_{OD}	Driver output (TXO) differential voltage	Idle	TXEN at 0.8 V, LOOP2 at 2 V, See Figure 1	LOOP1 at 2 V, See Figure 1		± 40	mV
		Active	TXEN at 2 V, LOOP2 at 2 V, See Figure 1	LOOP1 at 2 V, TXI at 3.2 V, See Figure 1	-600	1315	
		Active	TXEN at 2 V, LOOP2 at 2 V, See Figure 1	LOOP1 at 2 V, TXI at 4.4 V, See Figure 1	600	1315	
V_{OH}	High-level output voltage	RXO, RXEN	$I_{OH} = -0.4 \text{ mA}$		2.4	V	
V_{OL}	Low-level output voltage	RXO, RXEN	$I_{OL} = 16 \text{ mA}$		0.5	V	
I_{IH}	High-level input current	TXEN, LOOP	$V_I = 2 \text{ V}$		20	μA	
		TXI	$V_I = 4.5 \text{ V}$		400		
		RXI, RXI	$V_{ID} = -0.5 \text{ V},$ $V_{IC} = 1 \text{ V to } 4.2 \text{ V}$		1000		
I_{IL}	Low-level input current	TXEN, LOOP	$V_I = 0.8 \text{ V}$		-200	μA	
		TXI	$V_I = 3.1 \text{ V}$		100		
		RXI, RXI	$V_{ID} = 0.5 \text{ V},$ $V_{IC} = 1 \text{ V to } 4.2 \text{ V}$		1000		
I_{OD}	Driver differential output current	Idle	TXEN at 0.8 V, LOOP2 at 2 V, See Figure 2	LOOP1 at 2 V, See Figure 2		± 4	mA
I_{OS}	Short-circuit output current [†]	RXO, RXEN	V_O at 0 V, RXI at 2 V	RXI at 3 V,	-40	-150	mA
I_{CC}	Supply current		LOOP2 at 2 V, TXI at 4.5 V,	TXEN at 2 V, Outputs open		225	mA

[†] Not more than one output should be shorted at a time, and the duration of the test should not exceed 1 second.



SN75ALS085

LAN ACCESS UNIT INTERFACE DUAL DRIVER/RECEIVER

SLLS054D – APRIL 1989 – REVISED OCTOBER 2001

electrical characteristics over recommended ranges of supply voltage and operating free-air temperature (unless otherwise noted) (continued)

PARAMETER	TEST CONDITIONS	MIN	MAX	UNIT
Driver fault condition current [‡]	TXO shorted to $\overline{\text{TXO}}$, Current measured in short		150	mA
	TXO at 0 V, $\overline{\text{TXO}}$ is open, Current measured at TXO		150	
	TXO is open, $\overline{\text{TXO}}$ at 0, Current measured at $\overline{\text{TXO}}$		150	
	TXO at 0 V, $\overline{\text{TXO}}$ at 0 V, Current measured at TXO and $\overline{\text{TXO}}$		150	
	TXO at 16 V, $\overline{\text{TXO}}$ is open, Current measured at TXO		150	
	TXO is open, $\overline{\text{TXO}}$ at 16 V, Current measured at TXO		150	
	TXO at 16 V, $\overline{\text{TXO}}$ at 16 V, Current measured at TXO and $\overline{\text{TXO}}$		150	
Receiver fault condition current [‡]	RXI shorted to $\overline{\text{RXI}}$, Current measured in short		10	mA
	RXI at 0 V, $\overline{\text{RXI}}$ is open, Current measured at RXI		3	
	RXI is open, $\overline{\text{RXI}}$ at 0 V, Current measured at RXI		3	
	RXI at 0 V, $\overline{\text{RXI}}$ at 0 V, Current measured at RXI and $\overline{\text{RXI}}$		3	
	RXI at 16 V, $\overline{\text{RXI}}$ at open, Current measured at RXI		10	
	RXI at open, $\overline{\text{RXI}}$ at 16 V, Current measured at $\overline{\text{RXI}}$		10	
	RXI at 16 V, $\overline{\text{RXI}}$ at 16 V, Current measured at RXI and $\overline{\text{RXI}}$		10	

[‡] Fault conditions should be measured on only one channel at a time.

switching characteristics over recommended ranges of supply voltage and operating free-air temperature (unless otherwise noted)

driver

PARAMETER	FROM (INPUT)	TO (OUTPUT)	TEST CONDITIONS	MIN	MAX	UNIT
t _{PLH}	TXI	TXO, $\overline{\text{TXO}}$	TXEN at 2 V, See Figure 3		15	ns
t _{PHL}	TXI	TXO, $\overline{\text{TXO}}$	TXEN at 2 V, See Figure 3		15	ns
t _{PIL}	TXI	TXO, $\overline{\text{TXO}}$	TXEN at 2 V, See Figure 4		25	ns
t _{PIL}	TXEN	TXO, $\overline{\text{TXO}}$	TXI at 3.2 V, See Figure 5		25	ns
t _w		TXO, $\overline{\text{TXO}}$	TXEN at 2 V, See Figure 6	260	8000	ns
V _{OD(U)}	TXI	TXO, $\overline{\text{TXO}}$	TXEN at 2 V, See Figure 6		-100	mV
t _{sk}	TXI	TXO, $\overline{\text{TXO}}$	TXEN at 2 V, See Figure 3		±3	ns
t _r			TXEN at 2 V, See Figure 3	1	5	ns
t _f			TXEN at 2 V, See Figure 3	1	5	ns



SN75ALS085

LAN ACCESS UNIT INTERFACE DUAL DRIVER/RECEIVER

SLLS054D – APRIL 1989 – REVISED OCTOBER 2001

receiver

PARAMETER		FROM (INPUT)	TO (OUTPUT)	TEST CONDITIONS	MIN	MAX	UNIT
t _{PLH}	Propagation delay time, low-to-high level output	$\overline{\text{RXI}}$, RXI	R XO	V _{IC} = 1 V to 4.2 V, See Figure 10		15	ns
t _{PHL}	Propagation delay time, high-to-low level output	$\overline{\text{RXI}}$, RXI	R XO	V _{IC} = 1 V to 4.2 V, See Figure 10		15	ns
t _{PLH}	Start-up delay time, low-to-high level output	$\overline{\text{RXI}}$, RXI	R XEN	V _{IC} = 1 V to 4.2 V, V _{ID} = -500 mV, See Figure 12		55	ns
t _{PHL}	Shutdown delay time, high-to-low level output	$\overline{\text{RXI}}$, RXI	R XEN	V _{IC} = 1 V to 4.2 V, V _{ID} = 500 mV, See Figure 12	142	181	ns
t _{sk}	Receiver caused signal skew (t _{PLH} - t _{PHL})	$\overline{\text{RXI}}$, RXI	R XO	V _{IC} = 1 V to 4.2 V, V _{ID} = 500 mV, See Figure 10		±3	ns
t _w	Pulse duration at $\overline{\text{RXI}}$ and RXI (to not activate squelch)			V _{IC} = 1 V to 4.2 V, V _{ID} = -175 mV, See Figure 11	25		ns
t _w	Pulse duration at $\overline{\text{RXI}}$ and RXI (to activate squelch)			V _{IC} = 1 V to 4.2 V, V _{ID} = -275 mV, See Figure 11		50	ns
t _{r1}	Rise time, R XO			V _{IC} = 1 V to 4.2 V, V _{ID} = ±500 mV, See Figure 10	1	8	ns
t _{r2}	Rise time, R XEN			V _{IC} = 1 V to 4.2 V, V _{ID} = ±500 mV, See Figure 12	1	8	ns
t _{f1}	Fall time, R XO			V _{IC} = 1 V to 4.2 V, V _{ID} = ±500 mV, See Figure 10	1	8	ns
t _{f2}	Fall time, R XEN			V _{IC} = 2.5 V, V _{ID} = ±500 V, See Figure 12	1	8	ns
t _v	R XO valid after R XEN high			See Figure 10	-10	15	ns

loop

PARAMETER		FROM (INPUT)	TO (OUTPUT)	TEST CONDITIONS	MIN	MAX	UNIT
t _{PLH}	Propagation delay time, low-to-high level output	TXI	R XO	$\overline{\text{LOOP}}$ at 0.8 V, TXEN at 2 V, See Figure 13		30	ns
t _{PHL}	Propagation delay time, high-to-low level output	TXI	R XO	$\overline{\text{LOOP}}$ at 0.8 V, TXEN at 2 V, See Figure 13		30	ns
t _{PLH}	Propagation delay time, low-to-high level output	TXEN	R XEN	$\overline{\text{LOOP}}$ at 0.8 V, See Figure 14		50	ns
t _{PHL}	Propagation delay time, high-to-low level output	TXEN	R XEN	$\overline{\text{LOOP}}$ at 0.8 V, See Figure 14		50	ns

SN75ALS085 LAN ACCESS UNIT INTERFACE DUAL DRIVER/RECEIVER

SLLS054D – APRIL 1989 – REVISED OCTOBER 2001

PARAMETER MEASUREMENT INFORMATION

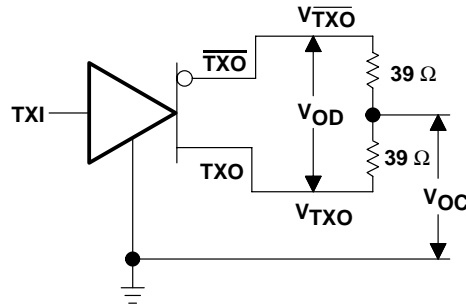

Figure 1. Driver Test Circuit

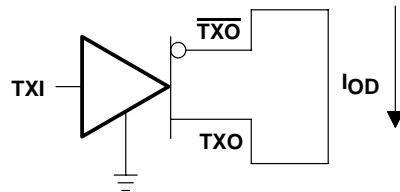
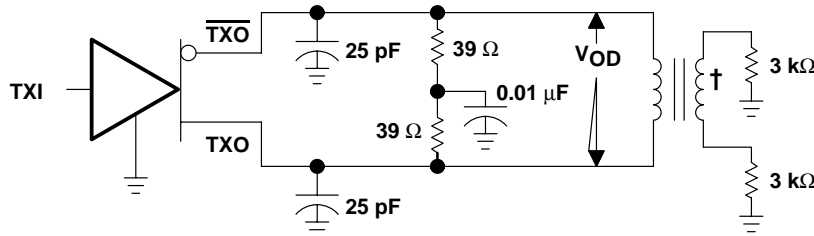
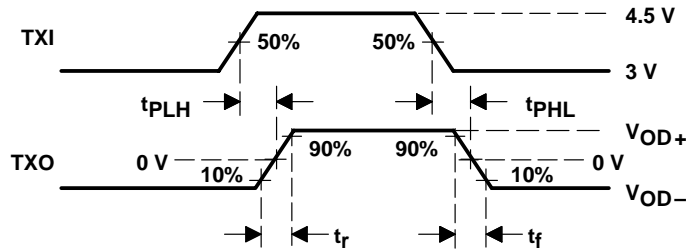

Figure 2. Driver Test Circuit



TEST CIRCUIT



VOLTAGE WAVEFORMS

† Transformer specifications:

Turns ratio	1:1
Magnetizing inductance	26 to 30 μ H
Winding resistance	0.6 Ω Max
Rise time 10% to 90%	5 ns Max
Interwinding capacitance	25 pF
Leakage inductance	0.25 μ H Max
Inductive Q	1250 Min

Figure 3. Test Circuit and Voltage Waveforms

PARAMETER MEASUREMENT INFORMATION

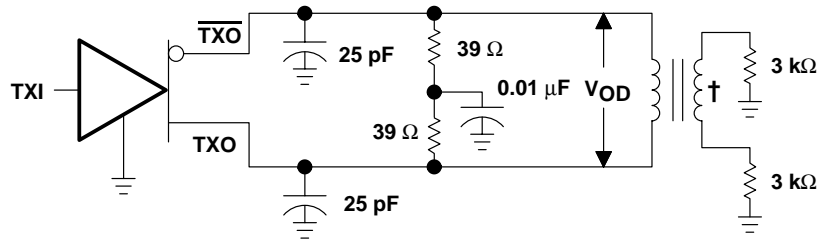

TEST CIRCUIT

† See Figure 3

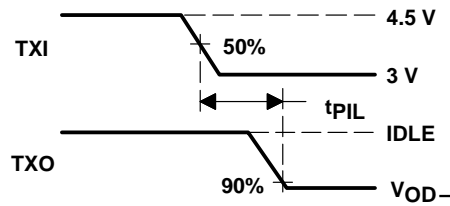

VOLTAGE WAVEFORMS

NOTE A: Input $t_r \leq 5$ ns; $t_f \leq 5$ ns

Figure 4. Test Circuit and Voltage Waveforms

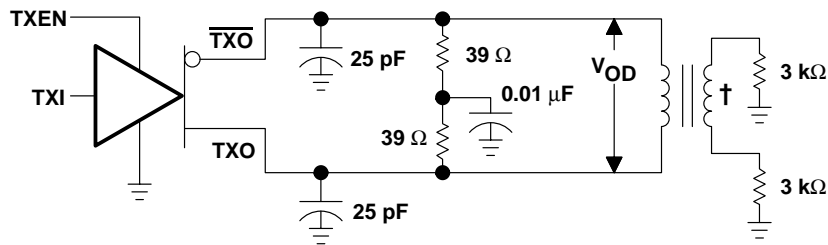

TEST CIRCUIT

† See Figure 3

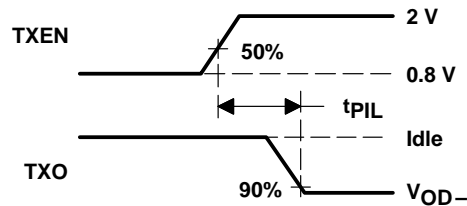

VOLTAGE WAVEFORMS

Figure 5. Test Circuit and Voltage Waveforms

SN75ALS085 LAN ACCESS UNIT INTERFACE DUAL DRIVER/RECEIVER

SLLS054D – APRIL 1989 – REVISED OCTOBER 2001

PARAMETER MEASUREMENT INFORMATION

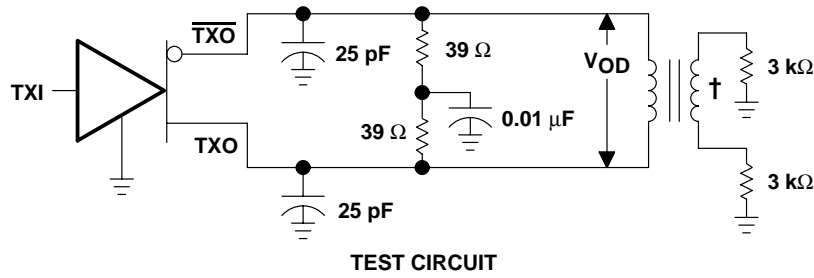

† See Figure 3

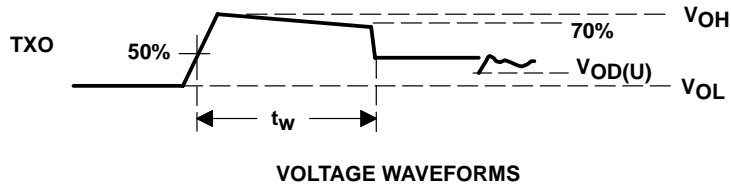

Figure 6. Test Circuit and Voltage Waveforms

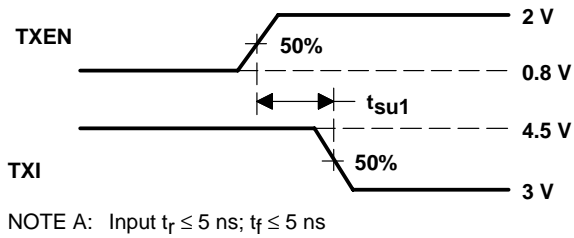

Figure 7

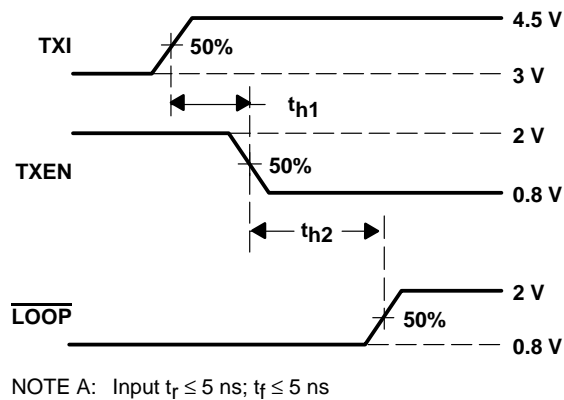

Figure 8

PARAMETER MEASUREMENT INFORMATION

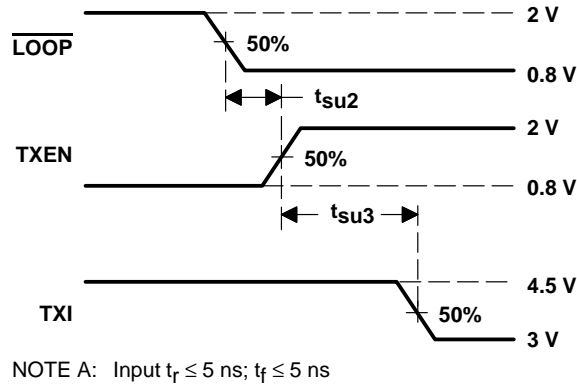

Figure 9

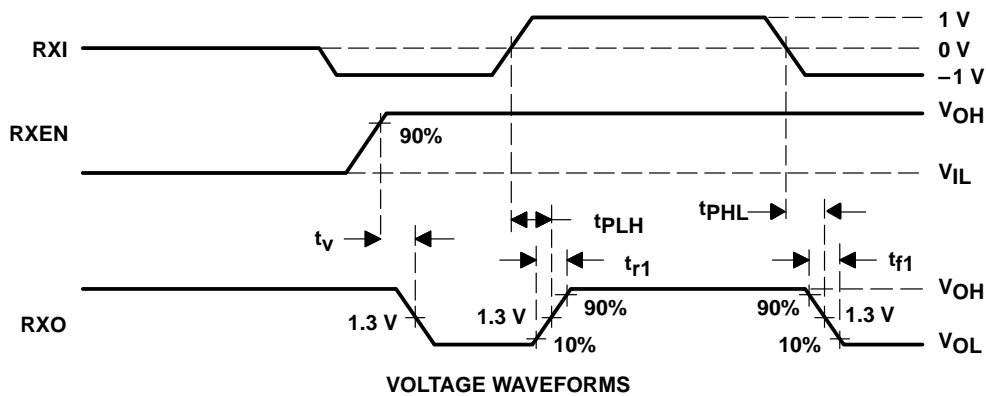
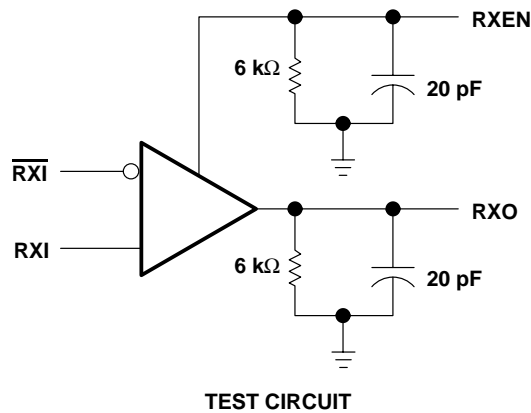

Figure 10. Test Circuit and Voltage Waveforms

SN75ALS085 LAN ACCESS UNIT INTERFACE DUAL DRIVER/RECEIVER

SLLS054D – APRIL 1989 – REVISED OCTOBER 2001

PARAMETER MEASUREMENT INFORMATION

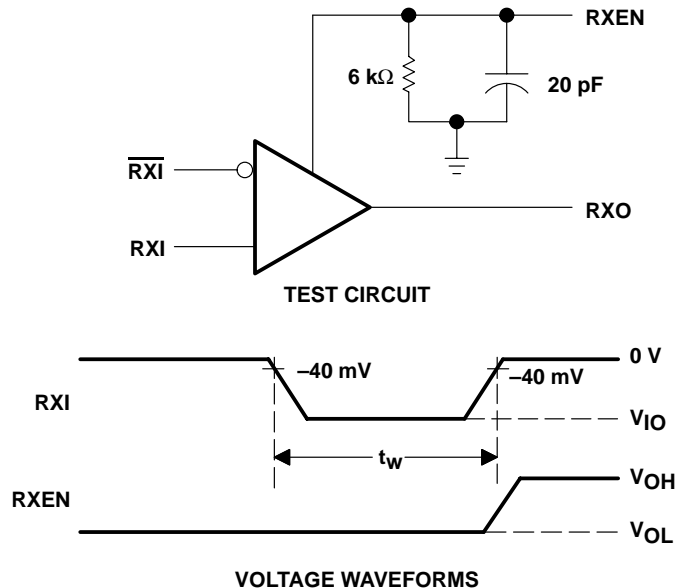

Figure 11. Test Circuit and Voltage Waveforms

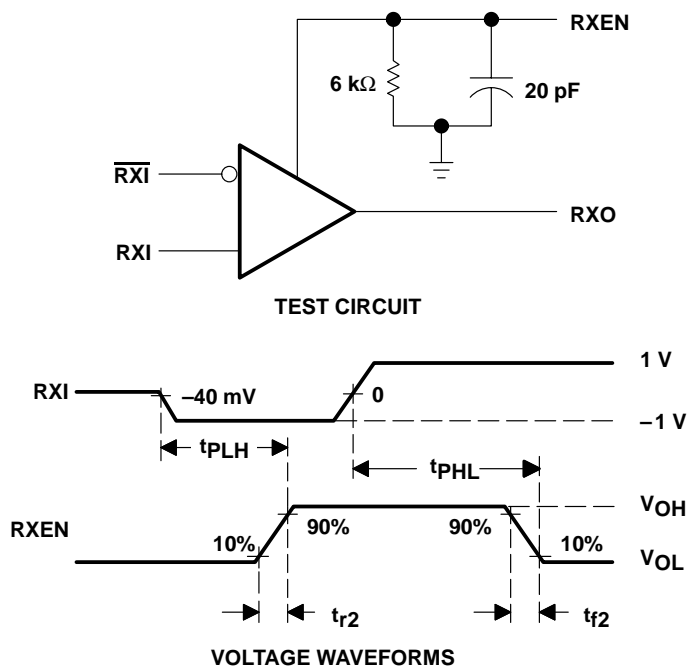
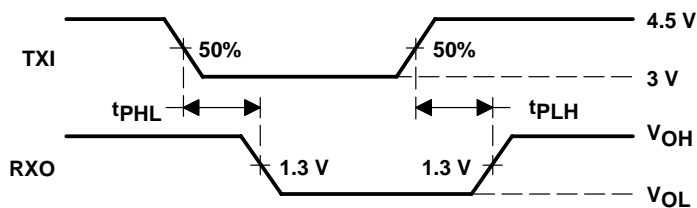

Figure 12. Test Circuit and Voltage Waveforms

PARAMETER MEASUREMENT INFORMATION



NOTE A: Input $t_r \leq 5$ ns; $t_f \leq 5$ ns

Figure 13

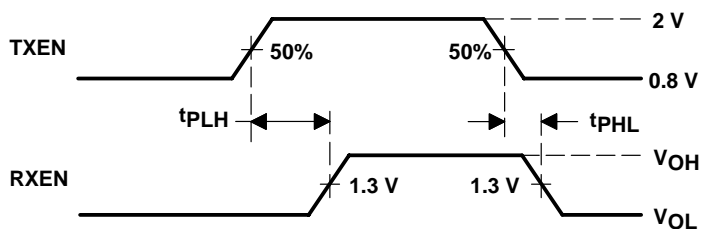

NOTE A: Input $t_r \leq 5$ ns; $t_f \leq 5$ ns

Figure 14

PACKAGING INFORMATION

Orderable Device	Status (1)	Package Type	Package Drawing	Pins	Package Qty	Eco Plan (2)	Lead/Ball Finish (6)	MSL Peak Temp (3)	Op Temp (°C)	Device Marking (4/5)	Samples
SN75ALS085DW	NRND	SOIC	DW	24	25	Green (RoHS & no Sb/Br)	CU NIPDAU	Level-1-260C-UNLIM	0 to 70	75ALS085	
SN75ALS085DWG4	NRND	SOIC	DW	24	25	Green (RoHS & no Sb/Br)	CU NIPDAU	Level-1-260C-UNLIM	0 to 70	75ALS085	

(1) The marketing status values are defined as follows:

ACTIVE: Product device recommended for new designs.

LIFEBUY: TI has announced that the device will be discontinued, and a lifetime-buy period is in effect.

NRND: Not recommended for new designs. Device is in production to support existing customers, but TI does not recommend using this part in a new design.

PREVIEW: Device has been announced but is not in production. Samples may or may not be available.

OBSELETE: TI has discontinued the production of the device.

(2) Eco Plan - The planned eco-friendly classification: Pb-Free (RoHS), Pb-Free (RoHS Exempt), or Green (RoHS & no Sb/Br) - please check <http://www.ti.com/productcontent> for the latest availability information and additional product content details.

TBD: The Pb-Free/Green conversion plan has not been defined.

Pb-Free (RoHS): TI's terms "Lead-Free" or "Pb-Free" mean semiconductor products that are compatible with the current RoHS requirements for all 6 substances, including the requirement that lead not exceed 0.1% by weight in homogeneous materials. Where designed to be soldered at high temperatures, TI Pb-Free products are suitable for use in specified lead-free processes.

Pb-Free (RoHS Exempt): This component has a RoHS exemption for either 1) lead-based flip-chip solder bumps used between the die and package, or 2) lead-based die adhesive used between the die and leadframe. The component is otherwise considered Pb-Free (RoHS compatible) as defined above.

Green (RoHS & no Sb/Br): TI defines "Green" to mean Pb-Free (RoHS compatible), and free of Bromine (Br) and Antimony (Sb) based flame retardants (Br or Sb do not exceed 0.1% by weight in homogeneous material)

(3) MSL, Peak Temp. - The Moisture Sensitivity Level rating according to the JEDEC industry standard classifications, and peak solder temperature.

(4) There may be additional marking, which relates to the logo, the lot trace code information, or the environmental category on the device.

(5) Multiple Device Markings will be inside parentheses. Only one Device Marking contained in parentheses and separated by a "~" will appear on a device. If a line is indented then it is a continuation of the previous line and the two combined represent the entire Device Marking for that device.

(6) Lead/Ball Finish - Orderable Devices may have multiple material finish options. Finish options are separated by a vertical ruled line. Lead/Ball Finish values may wrap to two lines if the finish value exceeds the maximum column width.

Important Information and Disclaimer: The information provided on this page represents TI's knowledge and belief as of the date that it is provided. TI bases its knowledge and belief on information provided by third parties, and makes no representation or warranty as to the accuracy of such information. Efforts are underway to better integrate information from third parties. TI has taken and continues to take reasonable steps to provide representative and accurate information but may not have conducted destructive testing or chemical analysis on incoming materials and chemicals. TI and TI suppliers consider certain information to be proprietary, and thus CAS numbers and other limited information may not be available for release.

In no event shall TI's liability arising out of such information exceed the total purchase price of the TI part(s) at issue in this document sold by TI to Customer on an annual basis.

DW (R-PDSO-G24)

PLASTIC SMALL OUTLINE



- NOTES:
- A. All linear dimensions are in inches (millimeters). Dimensioning and tolerancing per ASME Y14.5M-1994.
 - B. This drawing is subject to change without notice.
 - C. Body dimensions do not include mold flash or protrusion not to exceed 0.006 (0,15).
 - D. Falls within JEDEC MS-013 variation AD.

IMPORTANT NOTICE

Texas Instruments Incorporated and its subsidiaries (TI) reserve the right to make corrections, enhancements, improvements and other changes to its semiconductor products and services per JESD46, latest issue, and to discontinue any product or service per JESD48, latest issue. Buyers should obtain the latest relevant information before placing orders and should verify that such information is current and complete. All semiconductor products (also referred to herein as "components") are sold subject to TI's terms and conditions of sale supplied at the time of order acknowledgment.

TI warrants performance of its components to the specifications applicable at the time of sale, in accordance with the warranty in TI's terms and conditions of sale of semiconductor products. Testing and other quality control techniques are used to the extent TI deems necessary to support this warranty. Except where mandated by applicable law, testing of all parameters of each component is not necessarily performed.

TI assumes no liability for applications assistance or the design of Buyers' products. Buyers are responsible for their products and applications using TI components. To minimize the risks associated with Buyers' products and applications, Buyers should provide adequate design and operating safeguards.

TI does not warrant or represent that any license, either express or implied, is granted under any patent right, copyright, mask work right, or other intellectual property right relating to any combination, machine, or process in which TI components or services are used. Information published by TI regarding third-party products or services does not constitute a license to use such products or services or a warranty or endorsement thereof. Use of such information may require a license from a third party under the patents or other intellectual property of the third party, or a license from TI under the patents or other intellectual property of TI.

Reproduction of significant portions of TI information in TI data books or data sheets is permissible only if reproduction is without alteration and is accompanied by all associated warranties, conditions, limitations, and notices. TI is not responsible or liable for such altered documentation. Information of third parties may be subject to additional restrictions.

Resale of TI components or services with statements different from or beyond the parameters stated by TI for that component or service voids all express and any implied warranties for the associated TI component or service and is an unfair and deceptive business practice. TI is not responsible or liable for any such statements.

Buyer acknowledges and agrees that it is solely responsible for compliance with all legal, regulatory and safety-related requirements concerning its products, and any use of TI components in its applications, notwithstanding any applications-related information or support that may be provided by TI. Buyer represents and agrees that it has all the necessary expertise to create and implement safeguards which anticipate dangerous consequences of failures, monitor failures and their consequences, lessen the likelihood of failures that might cause harm and take appropriate remedial actions. Buyer will fully indemnify TI and its representatives against any damages arising out of the use of any TI components in safety-critical applications.

In some cases, TI components may be promoted specifically to facilitate safety-related applications. With such components, TI's goal is to help enable customers to design and create their own end-product solutions that meet applicable functional safety standards and requirements. Nonetheless, such components are subject to these terms.

No TI components are authorized for use in FDA Class III (or similar life-critical medical equipment) unless authorized officers of the parties have executed a special agreement specifically governing such use.

Only those TI components which TI has specifically designated as military grade or "enhanced plastic" are designed and intended for use in military/aerospace applications or environments. Buyer acknowledges and agrees that any military or aerospace use of TI components which have **not** been so designated is solely at the Buyer's risk, and that Buyer is solely responsible for compliance with all legal and regulatory requirements in connection with such use.

TI has specifically designated certain components as meeting ISO/TS16949 requirements, mainly for automotive use. In any case of use of non-designated products, TI will not be responsible for any failure to meet ISO/TS16949.

Products

Audio	www.ti.com/audio
Amplifiers	amplifier.ti.com
Data Converters	dataconverter.ti.com
DLP® Products	www.dlp.com
DSP	dsp.ti.com
Clocks and Timers	www.ti.com/clocks
Interface	interface.ti.com
Logic	logic.ti.com
Power Mgmt	power.ti.com
Microcontrollers	microcontroller.ti.com
RFID	www.ti-rfid.com
OMAP Applications Processors	www.ti.com/omap
Wireless Connectivity	www.ti.com/wirelessconnectivity

Applications

Automotive and Transportation	www.ti.com/automotive
Communications and Telecom	www.ti.com/communications
Computers and Peripherals	www.ti.com/computers
Consumer Electronics	www.ti.com/consumer-apps
Energy and Lighting	www.ti.com/energy
Industrial	www.ti.com/industrial
Medical	www.ti.com/medical
Security	www.ti.com/security
Space, Avionics and Defense	www.ti.com/space-avionics-defense
Video and Imaging	www.ti.com/video

TI E2E Community

e2e.ti.com