

# SN75ALS171, SN75ALS171A TRIPLE DIFFERENTIAL BUS TRANSCEIVERS

SLLS056D – AUGUST 1987 – REVISED SEPTEMBER 1995

- Three Bidirectional Transceivers
- Driver Meets or Exceeds the Requirements of ANSI EIA/TIA-422-B and RS-485 and ITU Recommendation V.11
- Two Skew Limits Available
- Designed to Operate Up to 20 Million Data Transfers per Second (FAST-20 SCSI)
- High-Speed Advanced Low-Power Schottky Circuitry
- Low Pulse Skew . . . 5 ns Max
- Designed for Multipoint Transmission on Long Bus Lines in Noisy Environments
- Features Independent Driver Enables and Combined Receiver Enables
- Wide Positive and Negative Input/Output Bus Voltages Ranges
- Driver Output Capacity . . .  $\pm 60$  mA
- Thermal Shutdown Protection
- Driver Positive- and Negative-Current Limiting
- Receiver Input Impedances . . . 12 k $\Omega$  Min
- Receiver Input Sensitivity . . .  $\pm 300$  mV Max
- Receiver Input Hysteresis . . . 60 mV Typ
- Operates From a Single 5-V Supply
- Glitch-Free Power-Up and Power-Down Protection

DW OR J PACKAGE  
(TOP VIEW)

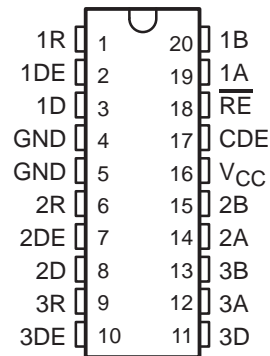

## description

The SN75ALS171 and the SN75ALS171A triple differential bus transceivers are monolithic integrated circuits designed for bidirectional data communication on multipoint bus transmission lines. They are designed for balanced transmission lines, and each driver meets ANSI Standards EIA/TIA-422-B and RS-485 and both the drivers and receivers meet ITU Recommendation V.11. The SN75ALS171A is designed for FAST-20 SCSI and can transmit or receive data pulses as short as 30 ns with a maximum skew of 5 ns.

The SN75ALS171 and the SN75ALS171A operate from a single 5-V power supply. The drivers and receivers have individual active-high and active-low enables, respectively, which can be externally connected together to function as a direction control. The driver differential output and the receiver differential input pairs are connected internally to form differential input/output (I/O) bus ports that are designed to offer minimum loading to the bus when the driver is disabled or V<sub>CC</sub> is at 0 V. These ports feature wide positive and negative common-mode voltage ranges making the device suitable for party-line applications.

The SN75ALS171 and the SN75ALS171A are characterized for operation from 0°C to 70°C.



Please be aware that an important notice concerning availability, standard warranty, and use in critical applications of Texas Instruments semiconductor products and disclaimers thereto appears at the end of this data sheet.

PRODUCTION DATA information is current as of publication date. Products conform to specifications per the terms of Texas Instruments standard warranty. Production processing does not necessarily include testing of all parameters.

 **TEXAS  
INSTRUMENTS**

POST OFFICE BOX 655303 • DALLAS, TEXAS 75265

Copyright © 1995, Texas Instruments Incorporated

# SN75ALS171, SN75ALS171A TRIPLE DIFFERENTIAL BUS TRANSCEIVERS

SLLS056D – AUGUST 1987 – REVISED SEPTEMBER 1995

## Function Tables

### EACH DRIVER

INPUT D	ENABLES		OUTPUTS	
	DE	CDE	A	B
H	H	H	H	L
L	H	H	L	H
X	L	X	Z	Z
X	X	L	Z	Z

### EACH RECEIVER

DIFFERENTIAL INPUTS A-B	ENABLE $\overline{RE}$	OUTPUT R
$V_{ID} \geq 0.3 V$	L	H
$-0.3 V < V_{ID} < 0.3 V$	L	?
$V_{ID} \leq -0.3 V$	L	L
X	H	Z
Open	L	H

H = high level, L = low level, ? = indeterminate, X = irrelevant,  
Z = high impedance (off)

### AVAILABLE OPTIONS

SKEW LIMIT	PART NUMBER	
10 ns	SN75ALS171DW	SN75ALS171J
5 ns	SN75ALS171ADW	

# SN75ALS171, SN75ALS171A TRIPLE DIFFERENTIAL BUS TRANSCEIVERS

SLLS056D – AUGUST 1987 – REVISED SEPTEMBER 1995

## logic symbol†

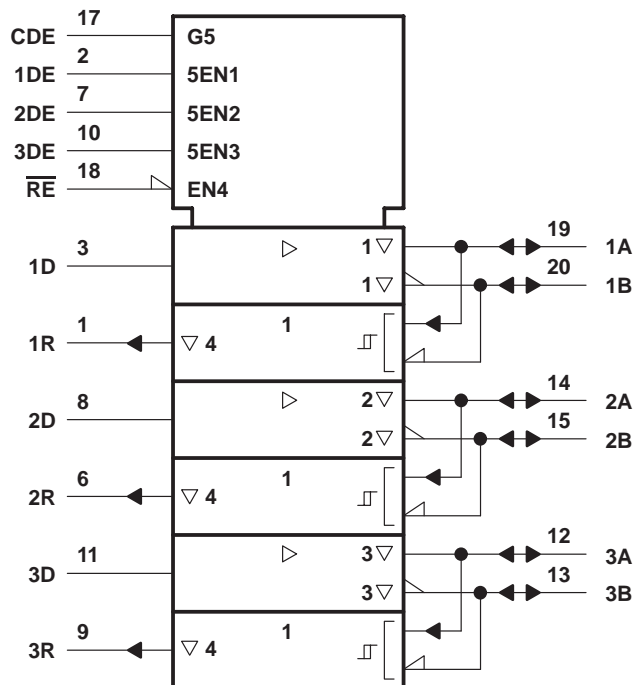

† This symbol is in accordance with ANSI/IEEE Std 91-1984 and IEC Publication 617-12.

## logic diagram (positive logic)

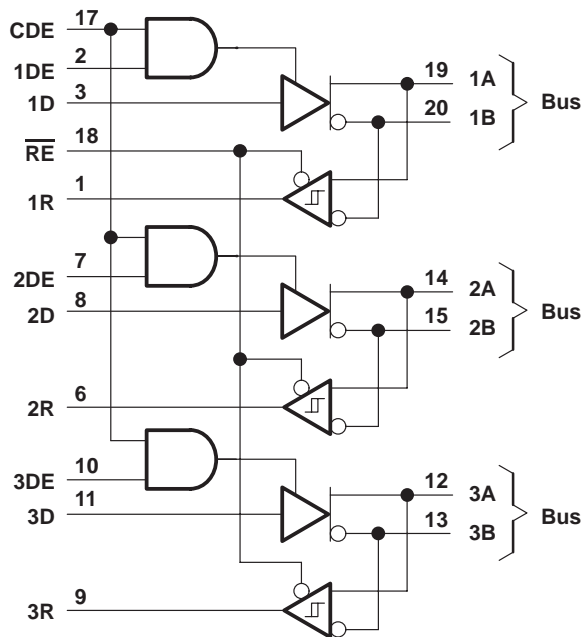

## schematics of inputs and outputs

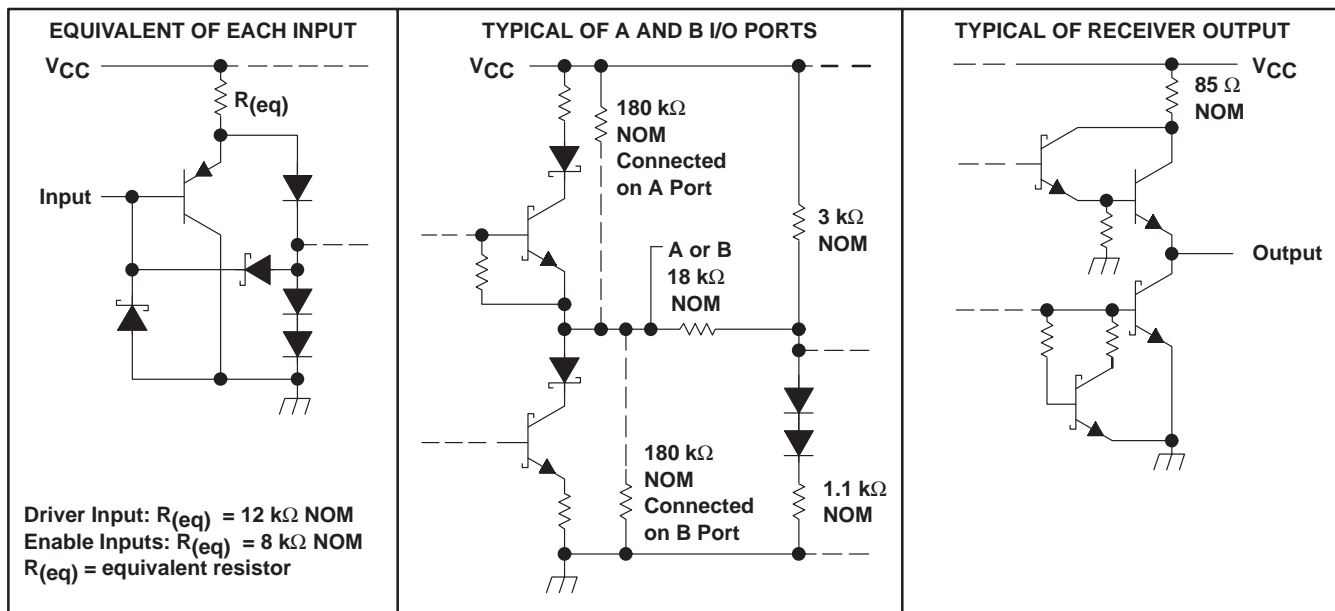

# SN75ALS171, SN75ALS171A TRIPLE DIFFERENTIAL BUS TRANSCEIVERS

SLLS056D – AUGUST 1987 – REVISED SEPTEMBER 1995

## absolute maximum ratings over operating free-air temperature range (unless otherwise noted)†

Supply voltage, $V_{CC}$ (see Note 1)	7 V
Voltage range at any bus terminal	-7 V to 12 V
Enable input voltage, $V_I$	7 V
Continuous total power dissipation	See Dissipation Rating Table
Operating free-air temperature range, $T_A$	0°C to 70°C
Storage temperature range, $T_{stg}$	-65°C to 150°C
Lead temperature 1,6 mm (1/16 inch) from case for 10 seconds: DW package	260°C
Lead temperature 1,6 mm (1/16 inch) from case for 60 seconds: J package	300°C

† Stresses beyond those listed under “absolute maximum ratings” may cause permanent damage to the device. These are stress ratings only, and functional operation of the device at these or any other conditions beyond those indicated under “recommended operating conditions” is not implied. Exposure to absolute-maximum-rated conditions for extended periods may affect device reliability.

NOTE 1: All voltage values, except differential I/O bus voltage, are with respect to network ground terminal.

DISSIPATION RATING TABLE

PACKAGE	$T_A \leq 25^\circ\text{C}$ POWER RATING	DERATING FACTOR ABOVE $T_A = 25^\circ\text{C}$	$T_A = 70^\circ\text{C}$ POWER RATING
DW	1125 mW	9.0 mW/°C	720 mW
J	1025 mW	8.2 mW/°C	656 mW

## recommended operating conditions

	MIN	NOM	MAX	UNIT
Supply voltage, $V_{CC}$	4.75	5	5.25	V
Voltage at any bus terminal (separately or common mode), $V_I$ or $V_{IC}$	-7		12	V
High-level input voltage, $V_{IH}$	D, CDE, DE, and $\overline{RE}$		2	V
Low-level input voltage, $V_{IL}$	D, CDE, DE, and $\overline{RE}$		0.8	V
Differential input voltage, $V_{ID}$ (see Note 2)			±12	V
High-level output current, $I_{OH}$	Driver		-60	mA
	Receiver		-400	µA
Low-level output current, $I_{OL}$	Driver		60	mA
	Receiver		8	
Operating free-air temperature, $T_A$	0		70	°C

NOTE 2: Differential-input/output bus voltage is measured at the noninverting terminal A with respect to the inverting terminal B.



# SN75ALS171, SN75ALS171A TRIPLE DIFFERENTIAL BUS TRANSCEIVERS

SLLS056D – AUGUST 1987 – REVISED SEPTEMBER 1995

## DRIVER SECTION

**electrical characteristics over recommended ranges of supply voltage and operating free-air temperature (unless otherwise noted)**

PARAMETER		TEST CONDITIONST		MIN	TYP‡	MAX	UNIT		
V <sub>IK</sub>	Input clamp voltage	I <sub>I</sub> = -18 mA				-1.5	V		
V <sub>O</sub>	Output voltage	I <sub>O</sub> = 0		0		6	V		
V <sub>OH</sub>	High-level output voltage	V <sub>CC</sub> = 4.75 V, V <sub>IL</sub> = 0.8 V,	V <sub>IH</sub> = 2 V, I <sub>OH</sub> = -55 mA	2.7			V		
V <sub>OL</sub>	Low-level output voltage	V <sub>CC</sub> = 4.75 V, V <sub>IL</sub> = 0.8 V,	V <sub>IH</sub> = 2 V, I <sub>OL</sub> = 55 mA			1.7	V		
V <sub>OD1</sub>	Differential output voltage	I <sub>O</sub> = 0		1.5		6	V		
V <sub>OD2</sub>	Differential output voltage	R <sub>L</sub> = 100 Ω,	See Figure 1	1/2 V <sub>OD1</sub> or 2§	2.5	5	V		
		R <sub>L</sub> = 54 Ω,	See Figure 1	1.5	2.5	5			
V <sub>OD3</sub>	Differential output voltage	V <sub>test</sub> = -7 V to 12 V, See Figure 2		1.5		5	V		
Δ V <sub>OD</sub>	Change in magnitude of differential output voltage¶	R <sub>L</sub> = 54 Ω or 100 Ω, See Figure 1				±0.2	V		
V <sub>OC</sub>	Common-mode output voltage					3	-1	V	
Δ V <sub>OC</sub>	Change in magnitude of common-mode output voltage¶							±0.2	V
I <sub>O</sub>	Output current	Output disabled, See Note 3		V <sub>O</sub> = 12 V		1	mA		
				V <sub>O</sub> = -7 V		-0.8			
I <sub>IH</sub>	High-level enable-input current	D and DE CDE		V <sub>IH</sub> = 2.7 V		20	μA		
						60			
I <sub>IL</sub>	Low-level enable-input current	D and DE CDE		V <sub>IL</sub> = 0.4 V		-100	μA		
						-900			
I <sub>OS</sub>	Short-circuit output current					V <sub>O</sub> = -6 V	-250		
						V <sub>O</sub> = 0	-150		
						V <sub>O</sub> = V <sub>CC</sub>	250		
						V <sub>O</sub> = 8 V	250		
I <sub>CC</sub>	Supply current	No load				Outputs enabled	69	90	mA
						Outputs disabled	57	78	

† The power-off measurement in ANSI Standard EIA/TIA-422-B applies to disabled outputs only and is not applied to combined inputs and outputs.

‡ All typical values are at V<sub>CC</sub> = 5 V and T<sub>A</sub> = 25°C.

§ The minimum V<sub>OD2</sub> with 100-Ω load is either 1/2 V<sub>OD2</sub> or 2 V, whichever is greater.

¶ Δ|V<sub>OD</sub>| and Δ|V<sub>OC</sub>| are the changes in magnitude of V<sub>OD</sub> and V<sub>OC</sub>, respectively, that occur when the input is changed from a high level to a low level.

NOTE 3: This applies for both power on and off; refer to EIA Standard RS-485 for exact conditions. The EIA/TIA-422-B limit does not apply for a combined driver and receiver terminal.

# SN75ALS171, SN75ALS171A

## TRIPLE DIFFERENTIAL BUS TRANSCEIVERS

SLLS056D – AUGUST 1987 – REVISED SEPTEMBER 1995

switching characteristics over recommended ranges of supply voltage and operating free-air temperature (unless otherwise noted)

PARAMETER		TEST CONDITIONS		MIN	TYP†	MAX	UNIT
t <sub>d(OD)</sub>	Differential output delay time	ALS171	R <sub>L</sub> = 54 Ω, See Figure 3,	3		13	ns
		ALS171A	C <sub>L</sub> = 50 pF	6		11	
		ALS171	R <sub>L1</sub> = R <sub>L3</sub> = 165 Ω, V <sub>TERM</sub> = 5 V, See Figure 6	3		13	
		ALS171A	C <sub>L</sub> = 60 pF, R <sub>L2</sub> = 75 Ω,	6		11	
t <sub>sk(p)</sub>	Pulse skew‡	R <sub>L</sub> = 54 Ω, See Figure 3	C <sub>L</sub> = 50 pF,		1	5	ns
		R <sub>L1</sub> = R <sub>L3</sub> = 165 Ω, C <sub>L</sub> = 60 pF,	R <sub>L2</sub> = 75 Ω, See Figure 6		1	5	ns
t <sub>sk(lim)</sub>	Skew limit§	ALS171	R <sub>L</sub> = 54 Ω, See Figure 3			10	ns
		ALS171A	C <sub>L</sub> = 50 pF,			5	
		ALS171	R <sub>L1</sub> = R <sub>L3</sub> = 165 Ω, R <sub>L2</sub> = 75 Ω, See Figure 6			10	
		ALS171A	C <sub>L</sub> = 60 pF,			5	
t <sub>t(OD)</sub>	Differential-output transition time	R <sub>L</sub> = 54 Ω, See Figure 3	C <sub>L</sub> = 50 pF,	3	8	13	ns
		R <sub>L1</sub> = R <sub>L3</sub> = 165 Ω, C <sub>L</sub> = 60 pF, See Figure 6	R <sub>L2</sub> = 75 Ω, V <sub>TERM</sub> = 5 V,	3	8	13	
t <sub>pZH</sub>	Output enable time to high level	R <sub>L</sub> = 110 Ω,	See Figure 4		30	50	ns
t <sub>pZL</sub>	Output enable time to low level	R <sub>L</sub> = 110 Ω,	See Figure 5		30	50	ns
t <sub>PHZ</sub>	Output disable time from high level	R <sub>L</sub> = 110 Ω,	See Figure 4	3	8	13	ns
t <sub>PLZ</sub>	Output disable time from low level	R <sub>L</sub> = 110 Ω,	See Figure 5	3	8	13	ns
t <sub>pDE</sub>	Differential-output enable time	R <sub>L1</sub> = R <sub>L3</sub> = 165 Ω, C <sub>L</sub> = 60 pF,	R <sub>L2</sub> = 75 Ω, See Figure 7	8	30	45	ns
t <sub>pDZ</sub>	Differential-output disable time			5	10	45	ns

† All typical values are at V<sub>CC</sub> = 5 V and T<sub>A</sub> = 25°C.

‡ Pulse skew is defined as the |t<sub>d(ODH)</sub> - t<sub>d(ODL)</sub>| of each channel.

§ Skew limit is the maximum difference in propagation delay times between any two channels of one device and between any two devices. This parameter is applicable at one V<sub>CC</sub> and operating temperature within the recommended operating conditions.

### SYMBOL EQUIVALENTS

DATA-SHEET PARAMETER	EIA/TIA-422-B	RS-485
V <sub>O</sub>	V <sub>0a</sub> , V <sub>0b</sub>	V <sub>0a</sub> , V <sub>0b</sub>
V <sub>OD1</sub>	V <sub>0</sub>	V <sub>0</sub>
V <sub>OD2</sub>	V <sub>t</sub> (R <sub>L</sub> = 100 Ω)	V <sub>t</sub> (R <sub>L</sub> = 54 Ω)
V <sub>OD3</sub>		V <sub>t</sub> (Test Termination Measurement 2)
V <sub>tst</sub>		V <sub>tst</sub>
Δ V <sub>OD</sub>	V <sub>t</sub>   -  V̄ <sub>t</sub>	V <sub>t</sub>   -  V̄ <sub>t</sub>
V <sub>OC</sub>	V <sub>os</sub>	V <sub>os</sub>
Δ V <sub>OC</sub>	V <sub>os</sub> - V̄ <sub>os</sub>	V <sub>os</sub> - V̄ <sub>os</sub>
I <sub>OS</sub>	I <sub>sa</sub>  ,  I <sub>sb</sub>	
I <sub>O</sub>	I <sub>xa</sub>  ,  I <sub>xb</sub>	I <sub>ia</sub> , I <sub>ib</sub>



# SN75ALS171, SN75ALS171A TRIPLE DIFFERENTIAL BUS TRANSCEIVERS

SLLS056D – AUGUST 1987 – REVISED SEPTEMBER 1995

## RECEIVER SECTION

**electrical characteristics over recommended ranges of common-mode input voltage, supply voltage, and operating free-air temperature (unless otherwise noted)**

PARAMETER		TEST CONDITIONS		MIN	TYP†	MAX	UNIT
$V_{IT+}$	Positive-going input threshold voltage	$V_O = 2.7\text{ V}$ ,	$I_O = -0.4\text{ mA}$			0.3	V
$V_{IT-}$	Negative-going input threshold voltage	$V_O = 0.5\text{ V}$ ,	$I_O = 8\text{ mA}$	$-0.3\ddagger$			V
$V_{hys}$	Hysteresis voltage ( $V_{IT+} - V_{IT-}$ )				60		mV
$V_{IK}$	Enable-input clamp voltage	$I_I = -18\text{ mA}$				-1.5	V
$V_{OH}$	High-level output voltage	$V_{ID} = 300\text{ mV}$ , See Figure 8	$I_{OH} = -400\text{ }\mu\text{A}$ ,	2.7			V
$V_{OL}$	Low-level output voltage	$V_{ID} = -300\text{ mV}$ , See Figure 8	$I_{OL} = 8\text{ mA}$ ,			0.45	V
$I_{OZ}$	High-impedance-state output current	$V_O = 0.4\text{ V to }2.4\text{ V}$				$\pm 20$	$\mu\text{A}$
$I_I$	Line input current	Other input = 0 V, See Note 4	$V_I = 12\text{ V}$			1	mA
			$V_I = -7\text{ V}$			-0.8	
$I_{IH}$	High-level enable-input current	$V_{IH} = 2.7\text{ V}$				60	$\mu\text{A}$
$I_{IL}$	Low-level enable-input current	$V_{IL} = 0.4\text{ V}$				-300	$\mu\text{A}$
$r_i$	Input resistance			12			k $\Omega$
$I_{OS}$	Short-circuit output current	$V_{ID} = 300\text{ mV}$ ,	$V_O = 0$	-15		-85	mA
$I_{CC}$	Supply current	No load	Outputs enabled		69	90	mA
			Outputs disabled		57	78	

† All typical values are at  $V_{CC} = 5\text{ V}$  and  $T_A = 25^\circ\text{C}$ .

‡ The algebraic convention, in which the less positive (more negative) limit is designated minimum, is used in this data sheet for common-mode input voltage and threshold voltage levels only.

NOTE 4: This applies for both power on and off; refer to EIA Standard RS-485 for exact conditions.

**switching characteristics over recommended ranges of supply voltage and operating free-air temperature range**

PARAMETER		TEST CONDITIONS	MIN	TYP†	MAX	UNIT
$t_{PLH}$	Propagation delay time, low- to high-level output	$V_{ID} = -1.5\text{ V to }1.5\text{ V}$ , $C_L = 15\text{ pF}$ , $T_A = 25^\circ\text{C}$ , See Figure 9	9		19	ns
			11		16	
$t_{PHL}$	Propagation delay time, high- to low-level output	$V_{ID} = -1.5\text{ V to }1.5\text{ V}$ , $C_L = 15\text{ pF}$ , $T_A = 25^\circ\text{C}$ , See Figure 9	9		19	ns
			11		16	
$t_{sk(p)}$	Pulse skew§	$V_{ID} = -1.5\text{ V to }1.5\text{ V}$ , $C_L = 15\text{ pF}$ , See Figure 9		2	5	ns
$t_{sk(lim)}$	Skew limit¶		ALS171			10
		ALS171A			5	
$t_{PZH}$	Output enable time to high level	$C_L = 15\text{ pF}$ , See Figure 10		7	14	ns
$t_{PZL}$	Output enable time to low level			7	14	ns
$t_{PHZ}$	Output disable time from high level	$C_L = 15\text{ pF}$ , See Figure 10		20	35	ns
$t_{PLZ}$	Output disable time from low level			8	17	ns

† All typical values are at  $V_{CC} = 5\text{ V}$  and  $T_A = 25^\circ\text{C}$ .

§ Pulse skew is defined as the  $|t_{PLH} - t_{PHL}|$  of each channel.

¶ Skew limit is the maximum difference in propagation delay times between any two channels of one device and between any two devices. This parameter is applicable at one  $V_{CC}$  and operating temperature within the recommended operating conditions.



# SN75ALS171, SN75ALS171A TRIPLE DIFFERENTIAL BUS TRANSCEIVERS

SLLS056D – AUGUST 1987 – REVISED SEPTEMBER 1995

## PARAMETER MEASUREMENT INFORMATION

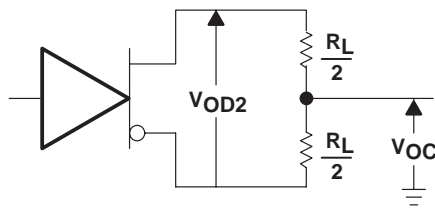

Figure 1. Driver  $V_{OD}$  and  $V_{OC}$

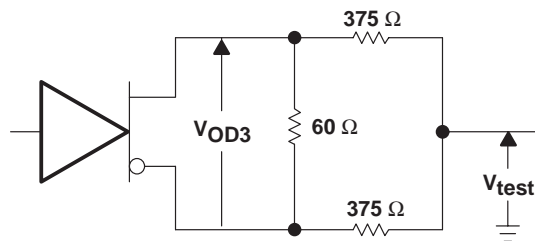
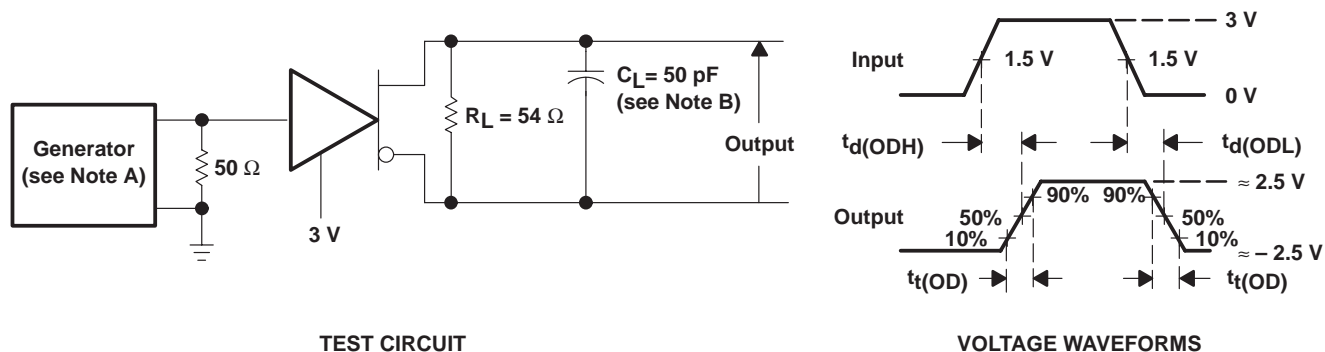

Figure 2. Driver  $V_{OD3}$



TEST CIRCUIT

VOLTAGE WAVEFORMS

- NOTES: A. The input pulse is supplied by a generator having the following characteristics:  $PRR \leq 1$  MHz, 50% duty cycle,  $t_r \leq 6$  ns,  $t_f \leq 6$  ns,  $Z_0 = 50 \Omega$ .  
 B.  $C_L$  includes probe and jig capacitance.

Figure 3. Driver Test Circuit and Voltage Waveforms

## PARAMETER MEASUREMENT INFORMATION

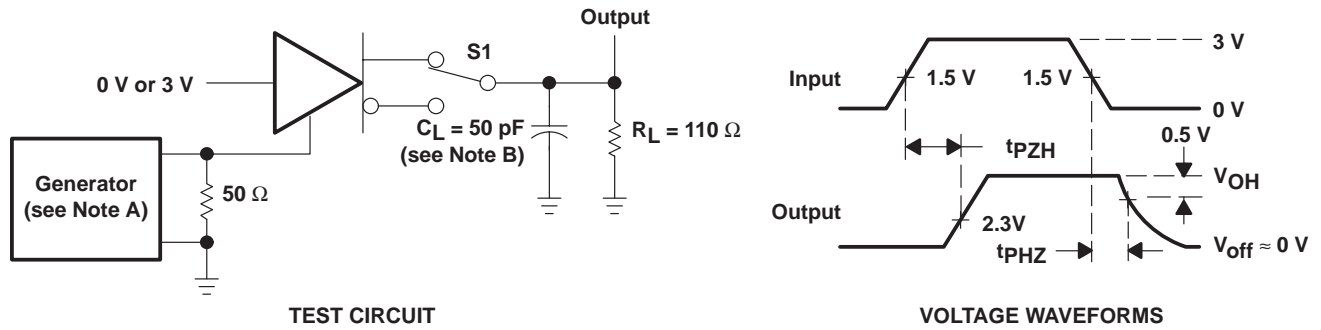

- NOTES: A. The input pulse is supplied by a generator having the following characteristics: PRR  $\leq$  1 MHz, 50% duty cycle,  $t_r \leq$  6 ns,  $t_f \leq$  6 ns,  $Z_O = 50 \Omega$ .  
 B.  $C_L$  includes probe and jig capacitance.

**Figure 4. Driver Test Circuit and Voltage Waveforms**

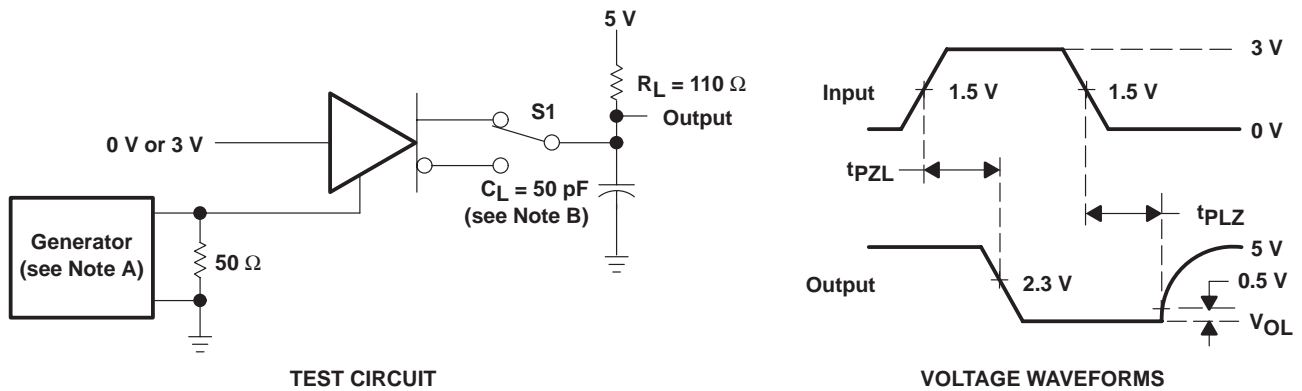

- NOTES: A. The input pulse is supplied by a generator having the following characteristics: PRR  $\leq$  1 MHz, 50% duty cycle,  $t_r \leq$  6 ns,  $t_f \leq$  6 ns,  $Z_O = 50 \Omega$ .  
 B.  $C_L$  includes probe and jig capacitance.

**Figure 5. Driver Test Circuit and Voltage Waveforms**

# SN75ALS171, SN75ALS171A TRIPLE DIFFERENTIAL BUS TRANSCEIVERS

SLLS056D – AUGUST 1987 – REVISED SEPTEMBER 1995

## PARAMETER MEASUREMENT INFORMATION

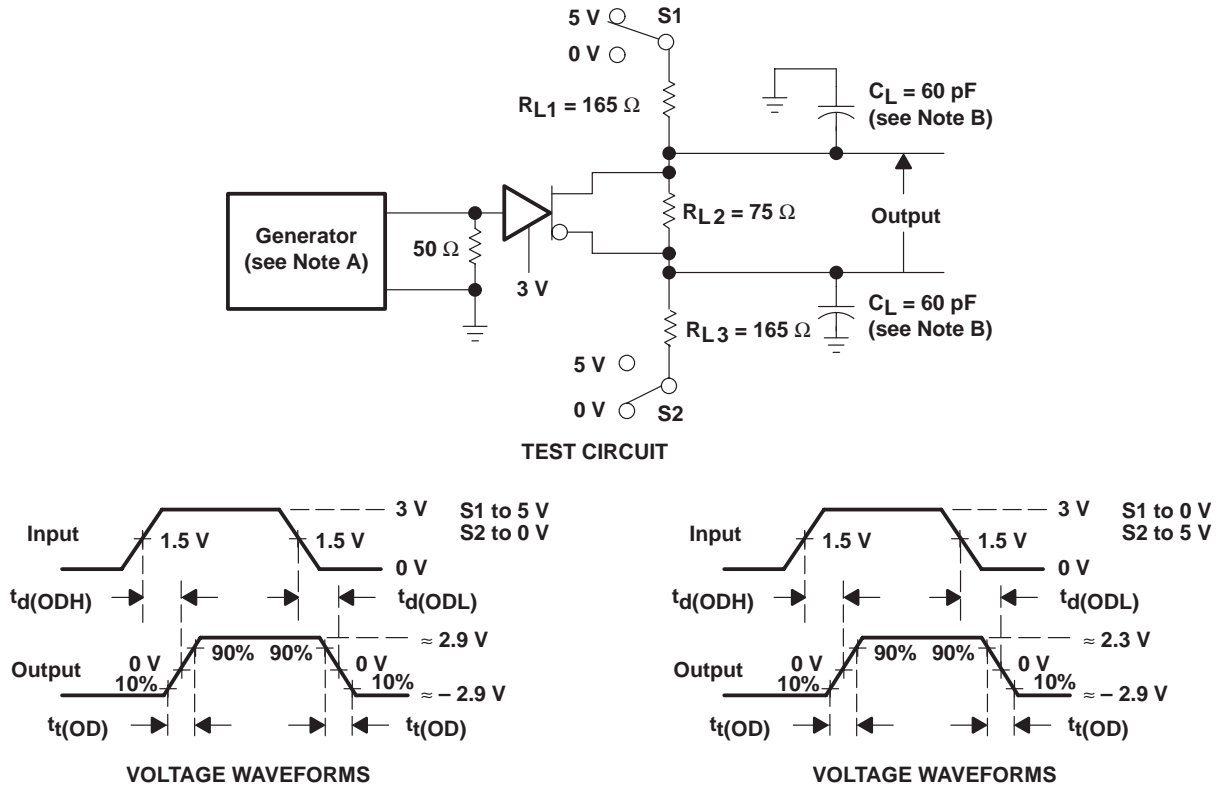

- NOTES: A. The input pulse is supplied by a generator having the following characteristics:  $PRR \leq 1$  MHz, 50% duty cycle,  $t_r \leq 6$  ns,  $t_f \leq 6$  ns,  $Z_O = 50 \Omega$ .
- B.  $C_L$  includes probe and jig capacitance.

**Figure 6. Driver Test Circuit and Voltage Waveforms  
With Double-Differential-SCSI Termination for the Load**

## PARAMETER MEASUREMENT INFORMATION

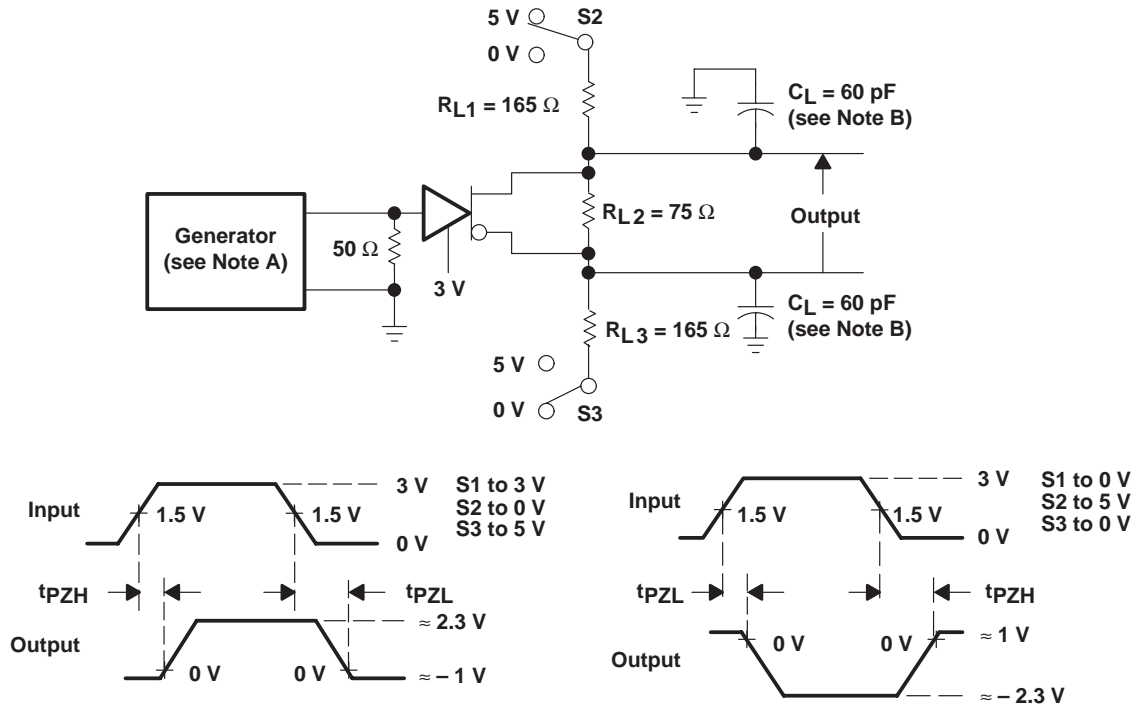

- NOTES: A. The input pulse is supplied by a generator having the following characteristics:  $PRR \leq 1 \text{ MHz}$ , 50% duty cycle,  $t_r \leq 6 \text{ ns}$ ,  $t_f \leq 6 \text{ ns}$ ,  $Z_O = 50 \Omega$ .
- B.  $C_L$  includes probe and jig capacitance.

**Figure 7. Driver Differential-Enable and Disable Times With a Double-SCSI Termination**

# SN75ALS171, SN75ALS171A TRIPLE DIFFERENTIAL BUS TRANSCEIVERS

SLLS056D – AUGUST 1987 – REVISED SEPTEMBER 1995

## PARAMETER MEASUREMENT INFORMATION

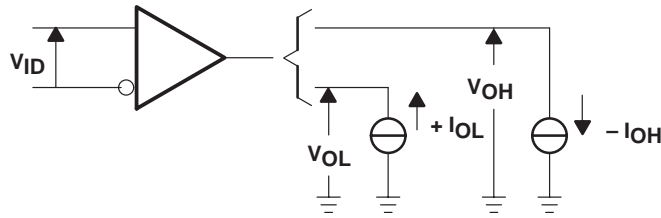
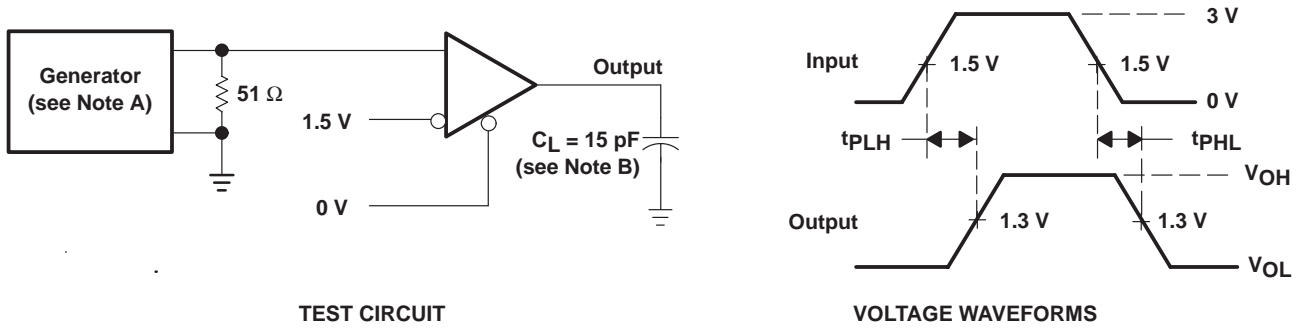

Figure 8. Receiver  $V_{OH}$  and  $V_{OL}$



TEST CIRCUIT

VOLTAGE WAVEFORMS

- NOTES: A. The input pulse is supplied by a generator having the following characteristics:  $PRR \leq 1$  MHz, 50% duty cycle,  $t_r \leq 6$  ns,  $t_f \leq 6$  ns,  $Z_O = 50 \Omega$ .  
 B.  $C_L$  includes probe and jig capacitance.

Figure 9. Receiver Test Circuit and Voltage Waveforms

## PARAMETER MEASUREMENT INFORMATION

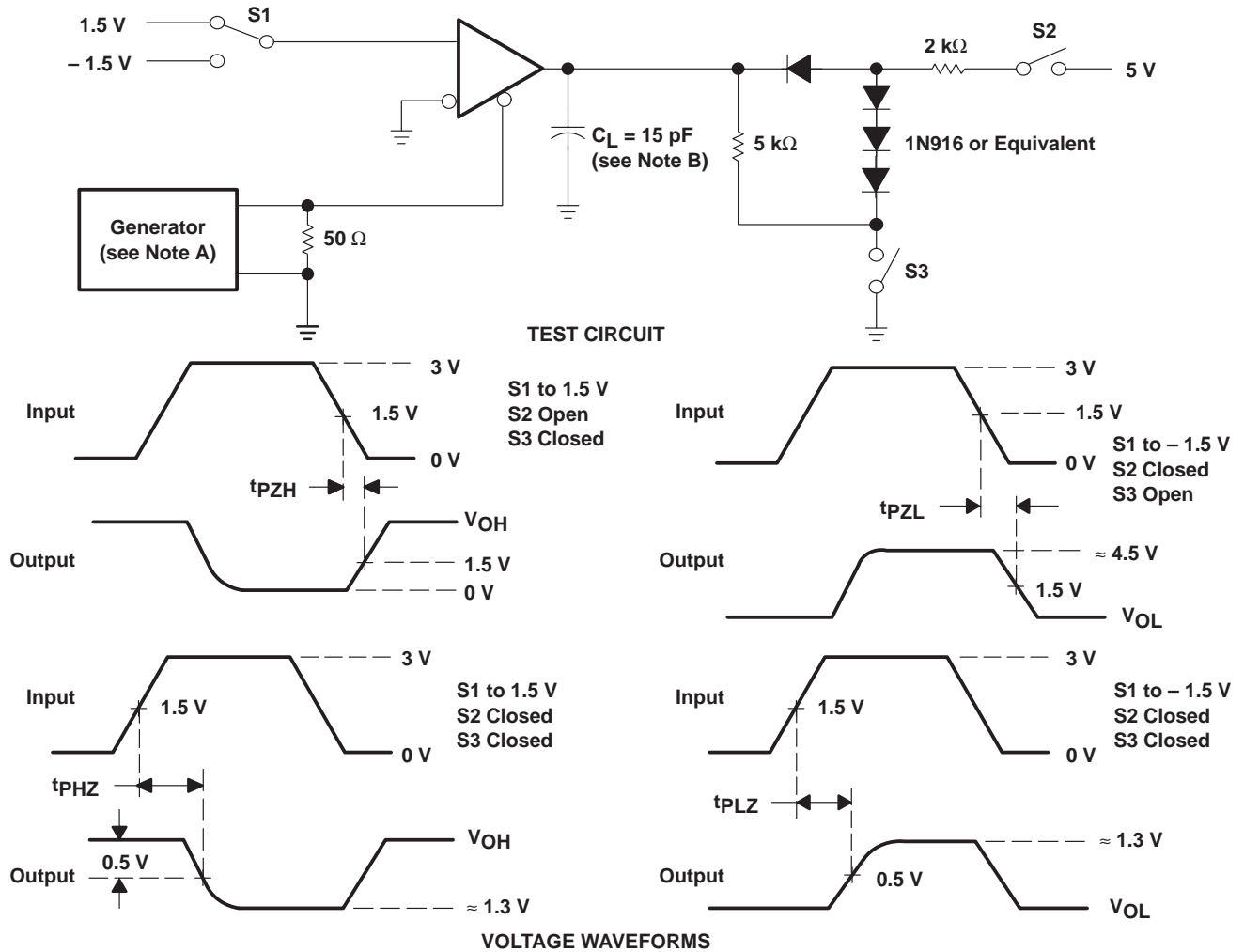

- NOTES: A. The input pulse is supplied by a generator having the following characteristics:  $PRR \leq 1$  MHz, 50% duty cycle,  $t_r \leq 6$  ns,  $t_f \leq 6$  ns,  $Z_O = 50 \Omega$ .  
 B.  $C_L$  includes probe and jig capacitance.

**Figure 10. Receiver Test Circuit and Voltage Waveforms**

# SN75ALS171, SN75ALS171A TRIPLE DIFFERENTIAL BUS TRANSCEIVERS

SLLS056D – AUGUST 1987 – REVISED SEPTEMBER 1995

## TYPICAL CHARACTERISTICS

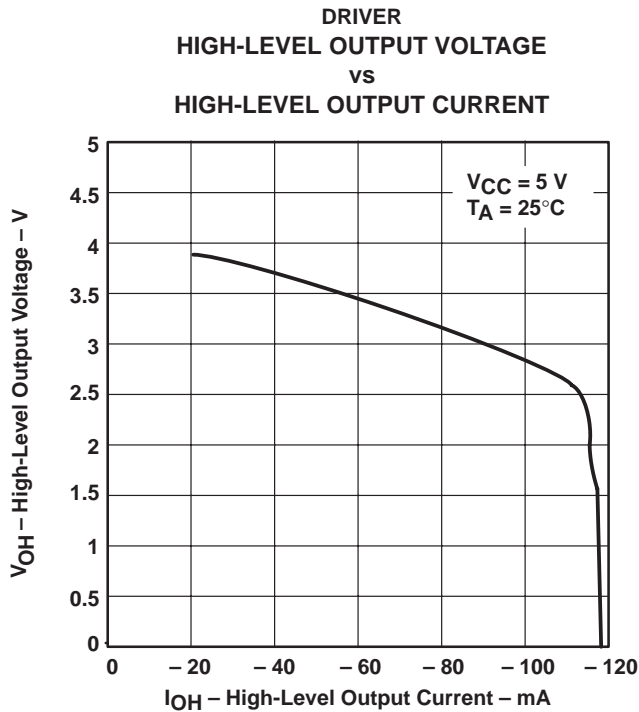

Figure 11

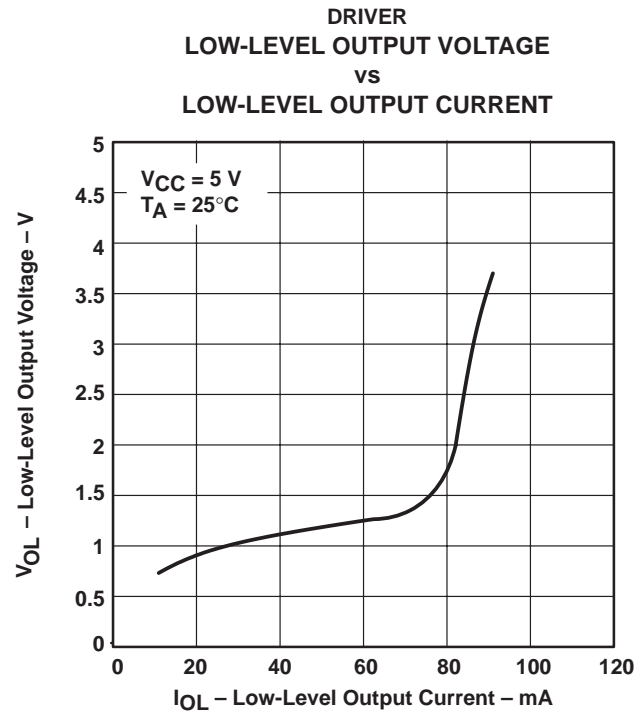

Figure 12

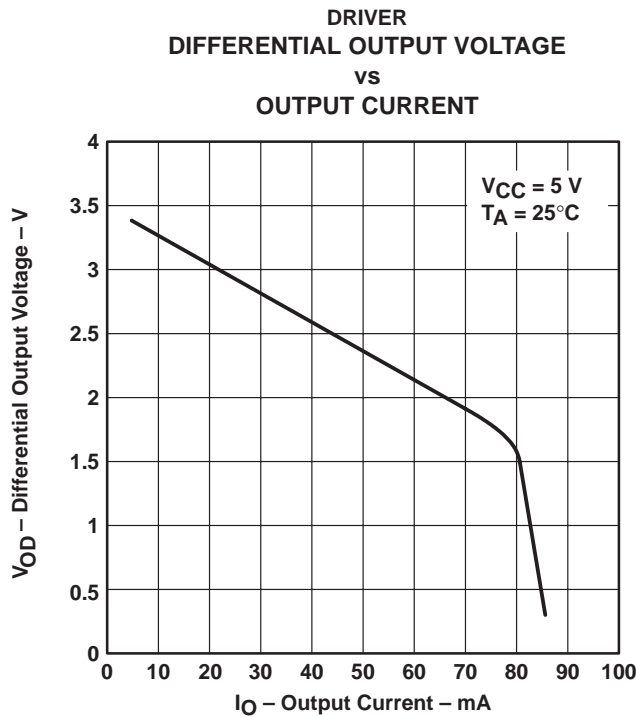

Figure 13



TYPICAL CHARACTERISTICS

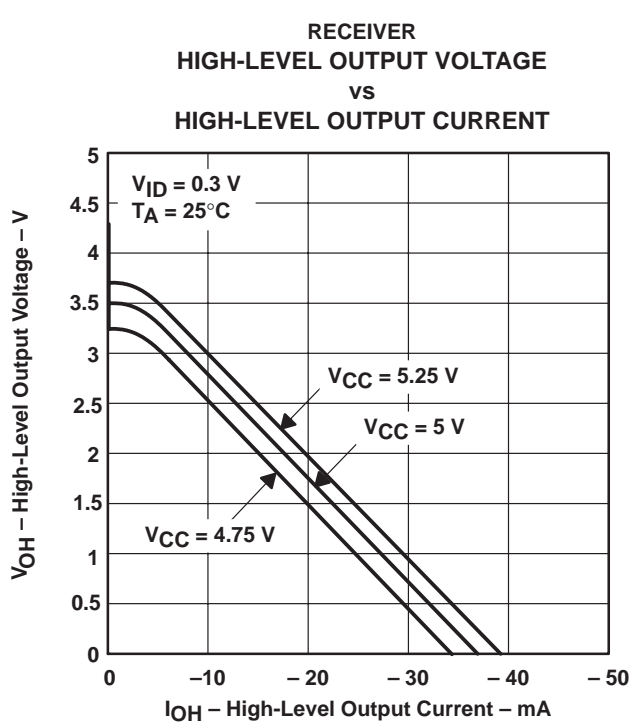

Figure 14

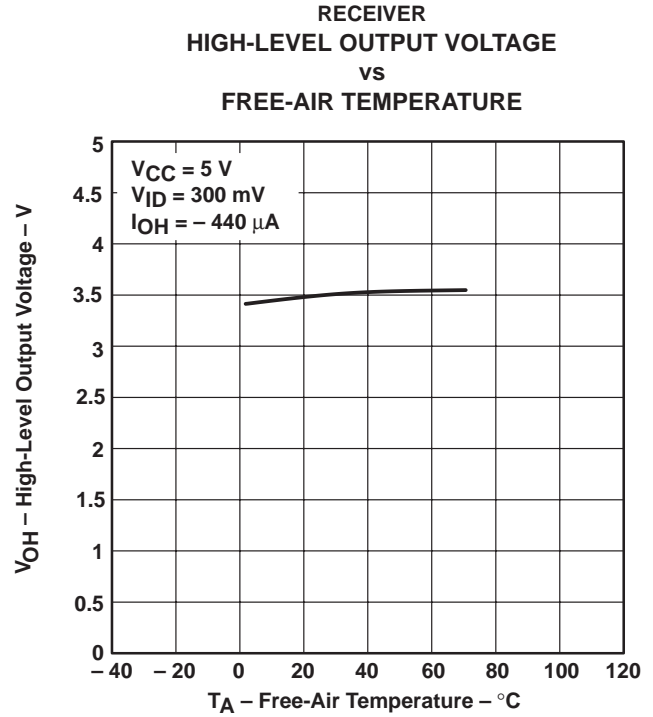

Figure 15

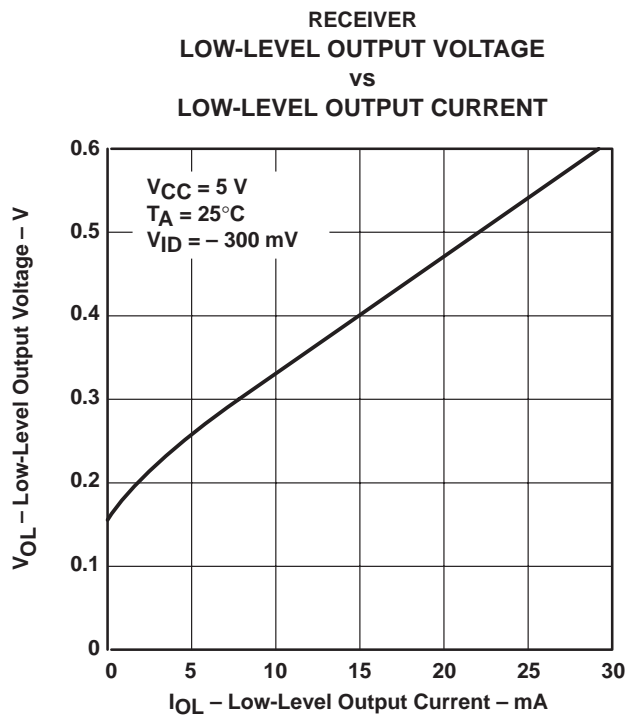

Figure 16

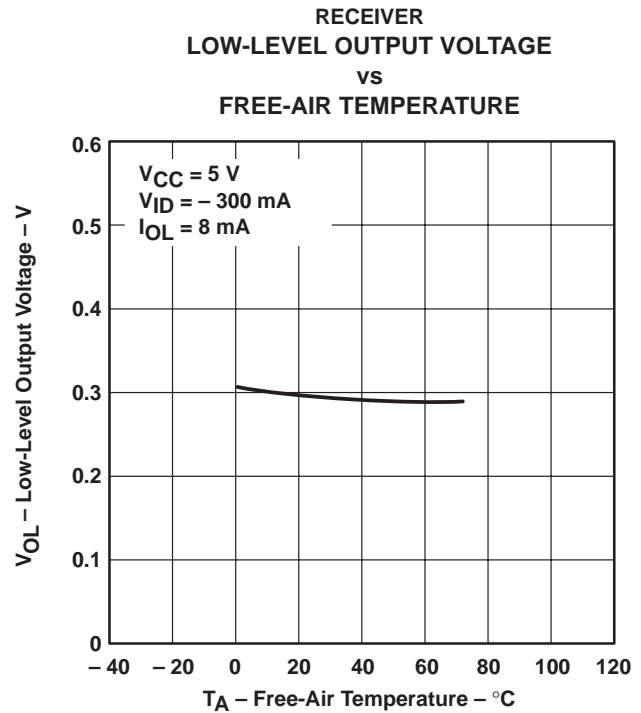

Figure 17

# SN75ALS171, SN75ALS171A TRIPLE DIFFERENTIAL BUS TRANSCEIVERS

SLLS056D – AUGUST 1987 – REVISED SEPTEMBER 1995

## TYPICAL CHARACTERISTICS

RECEIVER  
OUTPUT VOLTAGE  
vs  
ENABLE VOLTAGE

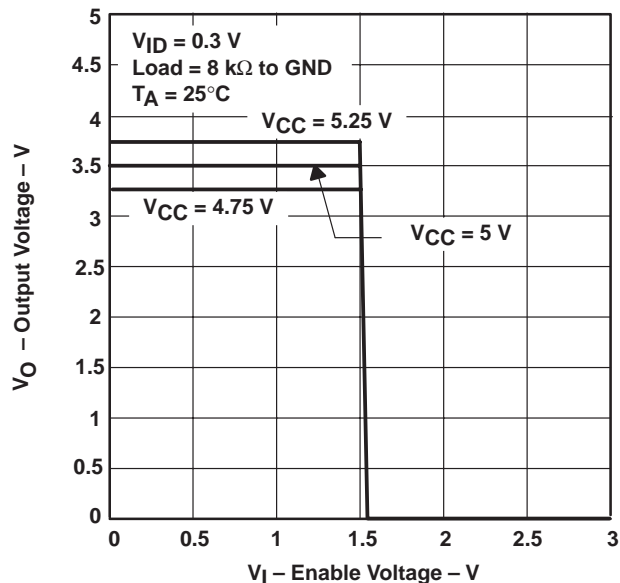

Figure 18

RECEIVER  
OUTPUT VOLTAGE  
vs  
ENABLE VOLTAGE

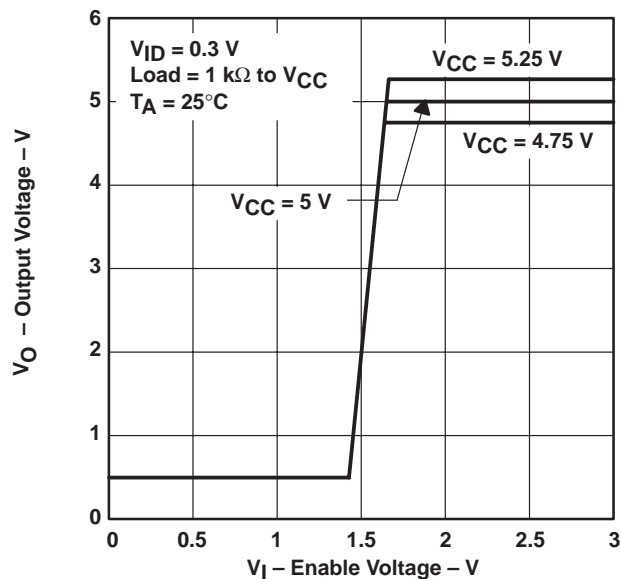
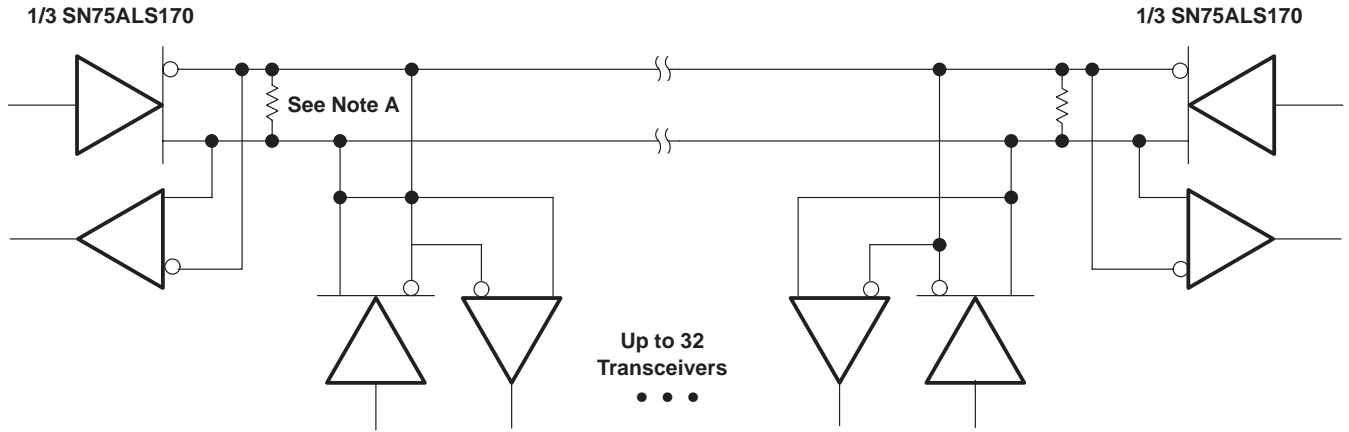

Figure 19

## APPLICATION INFORMATION



NOTE A: The line should be terminated at both ends in its characteristic impedance. Stub lengths off the main line should be kept as short as possible.

Figure 20. Typical Application Circuit

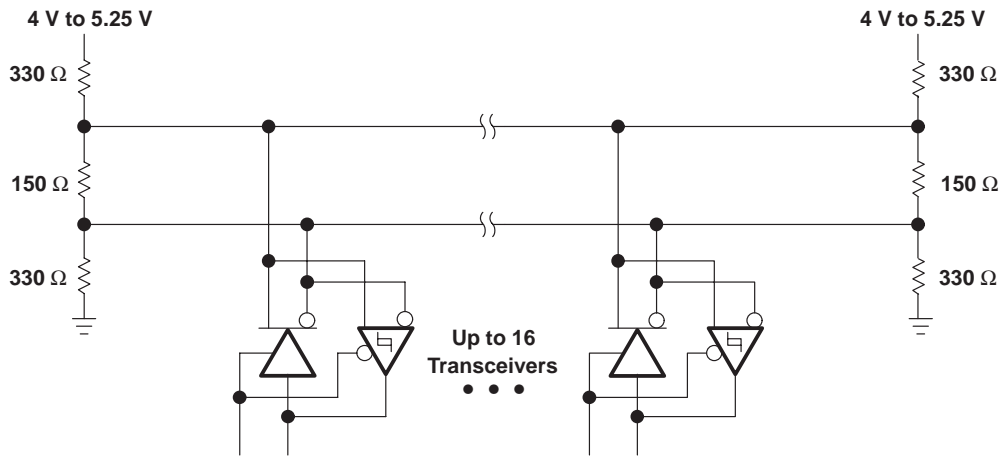

Figure 21. Typical Differential SCSI Application Circuit

# SN75ALS171, SN75ALS171A TRIPLE DIFFERENTIAL BUS TRANSCEIVERS

SLLS056D – AUGUST 1987 – REVISED SEPTEMBER 1995

## APPLICATION INFORMATION

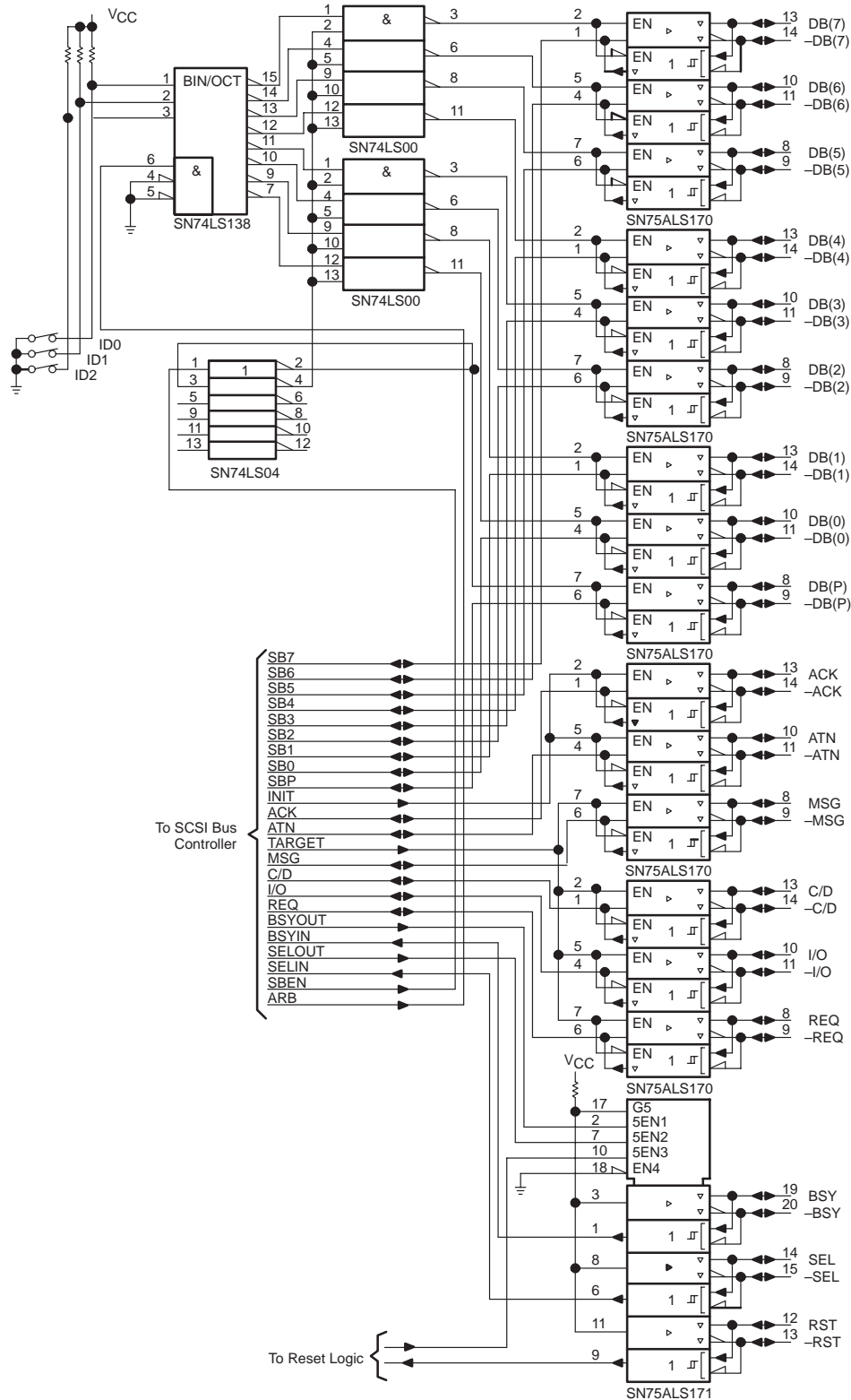

Figure 22. Typical Differential SCSI Bus Interface Implementation

**PACKAGING INFORMATION**

Orderable Device	Status (1)	Package Type	Package Drawing	Pins	Package Qty	Eco Plan (2)	Lead/Ball Finish (6)	MSL Peak Temp (3)	Op Temp (°C)	Device Marking (4/5)	Samples
SN75ALS171ADW	ACTIVE	SOIC	DW	20	25	Green (RoHS & no Sb/Br)	CU NIPDAU	Level-1-260C-UNLIM	0 to 70	75ALS171A	<a href="#">Samples</a>
SN75ALS171ADWR	ACTIVE	SOIC	DW	20	2000	Green (RoHS & no Sb/Br)	CU NIPDAU	Level-1-260C-UNLIM	0 to 70	75ALS171A	<a href="#">Samples</a>
SN75ALS171DW	ACTIVE	SOIC	DW	20	25	Green (RoHS & no Sb/Br)	CU NIPDAU	Level-1-260C-UNLIM	0 to 70	75ALS171	<a href="#">Samples</a>
SN75ALS171DWR	ACTIVE	SOIC	DW	20	2000	Green (RoHS & no Sb/Br)	CU NIPDAU	Level-1-260C-UNLIM	0 to 70	75ALS171	<a href="#">Samples</a>
SN75ALS171J	OBSOLETE	CDIP	J	20		TBD	Call TI	Call TI	0 to 70		

(1) The marketing status values are defined as follows:

**ACTIVE:** Product device recommended for new designs.

**LIFEBUY:** TI has announced that the device will be discontinued, and a lifetime-buy period is in effect.

**NRND:** Not recommended for new designs. Device is in production to support existing customers, but TI does not recommend using this part in a new design.

**PREVIEW:** Device has been announced but is not in production. Samples may or may not be available.

**OBSOLETE:** TI has discontinued the production of the device.

(2) Eco Plan - The planned eco-friendly classification: Pb-Free (RoHS), Pb-Free (RoHS Exempt), or Green (RoHS & no Sb/Br) - please check <http://www.ti.com/productcontent> for the latest availability information and additional product content details.

**TBD:** The Pb-Free/Green conversion plan has not been defined.

**Pb-Free (RoHS):** TI's terms "Lead-Free" or "Pb-Free" mean semiconductor products that are compatible with the current RoHS requirements for all 6 substances, including the requirement that lead not exceed 0.1% by weight in homogeneous materials. Where designed to be soldered at high temperatures, TI Pb-Free products are suitable for use in specified lead-free processes.

**Pb-Free (RoHS Exempt):** This component has a RoHS exemption for either 1) lead-based flip-chip solder bumps used between the die and package, or 2) lead-based die adhesive used between the die and leadframe. The component is otherwise considered Pb-Free (RoHS compatible) as defined above.

**Green (RoHS & no Sb/Br):** TI defines "Green" to mean Pb-Free (RoHS compatible), and free of Bromine (Br) and Antimony (Sb) based flame retardants (Br or Sb do not exceed 0.1% by weight in homogeneous material)

(3) MSL, Peak Temp. - The Moisture Sensitivity Level rating according to the JEDEC industry standard classifications, and peak solder temperature.

(4) There may be additional marking, which relates to the logo, the lot trace code information, or the environmental category on the device.

(5) Multiple Device Markings will be inside parentheses. Only one Device Marking contained in parentheses and separated by a "~" will appear on a device. If a line is indented then it is a continuation of the previous line and the two combined represent the entire Device Marking for that device.

(6) Lead/Ball Finish - Orderable Devices may have multiple material finish options. Finish options are separated by a vertical ruled line. Lead/Ball Finish values may wrap to two lines if the finish value exceeds the maximum column width.

**Important Information and Disclaimer:** The information provided on this page represents TI's knowledge and belief as of the date that it is provided. TI bases its knowledge and belief on information provided by third parties, and makes no representation or warranty as to the accuracy of such information. Efforts are underway to better integrate information from third parties. TI has taken and continues to take reasonable steps to provide representative and accurate information but may not have conducted destructive testing or chemical analysis on incoming materials and chemicals. TI and TI suppliers consider certain information to be proprietary, and thus CAS numbers and other limited information may not be available for release.

In no event shall TI's liability arising out of such information exceed the total purchase price of the TI part(s) at issue in this document sold by TI to Customer on an annual basis.

## TAPE AND REEL INFORMATION



### QUADRANT ASSIGNMENTS FOR PIN 1 ORIENTATION IN TAPE



\*All dimensions are nominal

Device	Package Type	Package Drawing	Pins	SPQ	Reel Diameter (mm)	Reel Width W1 (mm)	A0 (mm)	B0 (mm)	K0 (mm)	P1 (mm)	W (mm)	Pin1 Quadrant
SN75ALS171ADWR	SOIC	DW	20	2000	330.0	24.4	10.8	13.3	2.7	12.0	24.0	Q1
SN75ALS171DWR	SOIC	DW	20	2000	330.0	24.4	10.8	13.3	2.7	12.0	24.0	Q1

**TAPE AND REEL BOX DIMENSIONS**

\*All dimensions are nominal

Device	Package Type	Package Drawing	Pins	SPQ	Length (mm)	Width (mm)	Height (mm)
SN75ALS171ADWR	SOIC	DW	20	2000	367.0	367.0	45.0
SN75ALS171DWR	SOIC	DW	20	2000	367.0	367.0	45.0

J (R-GDIP-T\*\*)

14 LEADS SHOWN

CERAMIC DUAL IN-LINE PACKAGE



DIM \ PINS **	14	16	18	20
A	0.300 (7,62) BSC	0.300 (7,62) BSC	0.300 (7,62) BSC	0.300 (7,62) BSC
B MAX	0.785 (19,94)	.840 (21,34)	0.960 (24,38)	1.060 (26,92)
B MIN	—	—	—	—
C MAX	0.300 (7,62)	0.300 (7,62)	0.310 (7,87)	0.300 (7,62)
C MIN	0.245 (6,22)	0.245 (6,22)	0.220 (5,59)	0.245 (6,22)



4040083/F 03/03

- NOTES:
- All linear dimensions are in inches (millimeters).
  - This drawing is subject to change without notice.
  - This package is hermetically sealed with a ceramic lid using glass frit.
  - Index point is provided on cap for terminal identification only on press ceramic glass frit seal only.
  - Falls within MIL STD 1835 GDIP1-T14, GDIP1-T16, GDIP1-T18 and GDIP1-T20.

DW (R-PDSO-G20)

PLASTIC SMALL OUTLINE

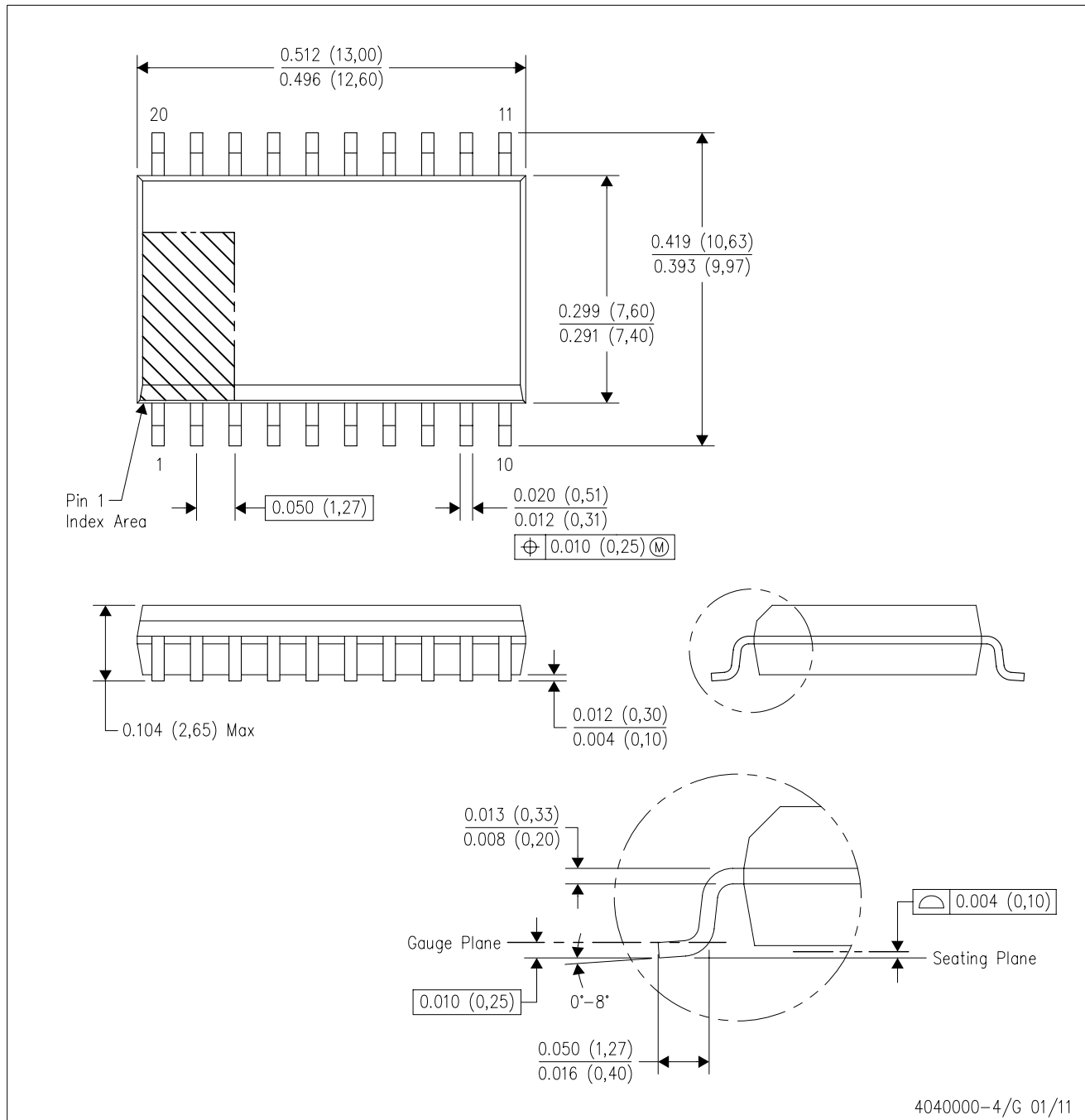

- NOTES:
- All linear dimensions are in inches (millimeters). Dimensioning and tolerancing per ASME Y14.5M-1994.
  - This drawing is subject to change without notice.
  - Body dimensions do not include mold flash or protrusion not to exceed 0.006 (0,15).
  - Falls within JEDEC MS-013 variation AC.

DW (R-PDSO-G20)

PLASTIC SMALL OUTLINE

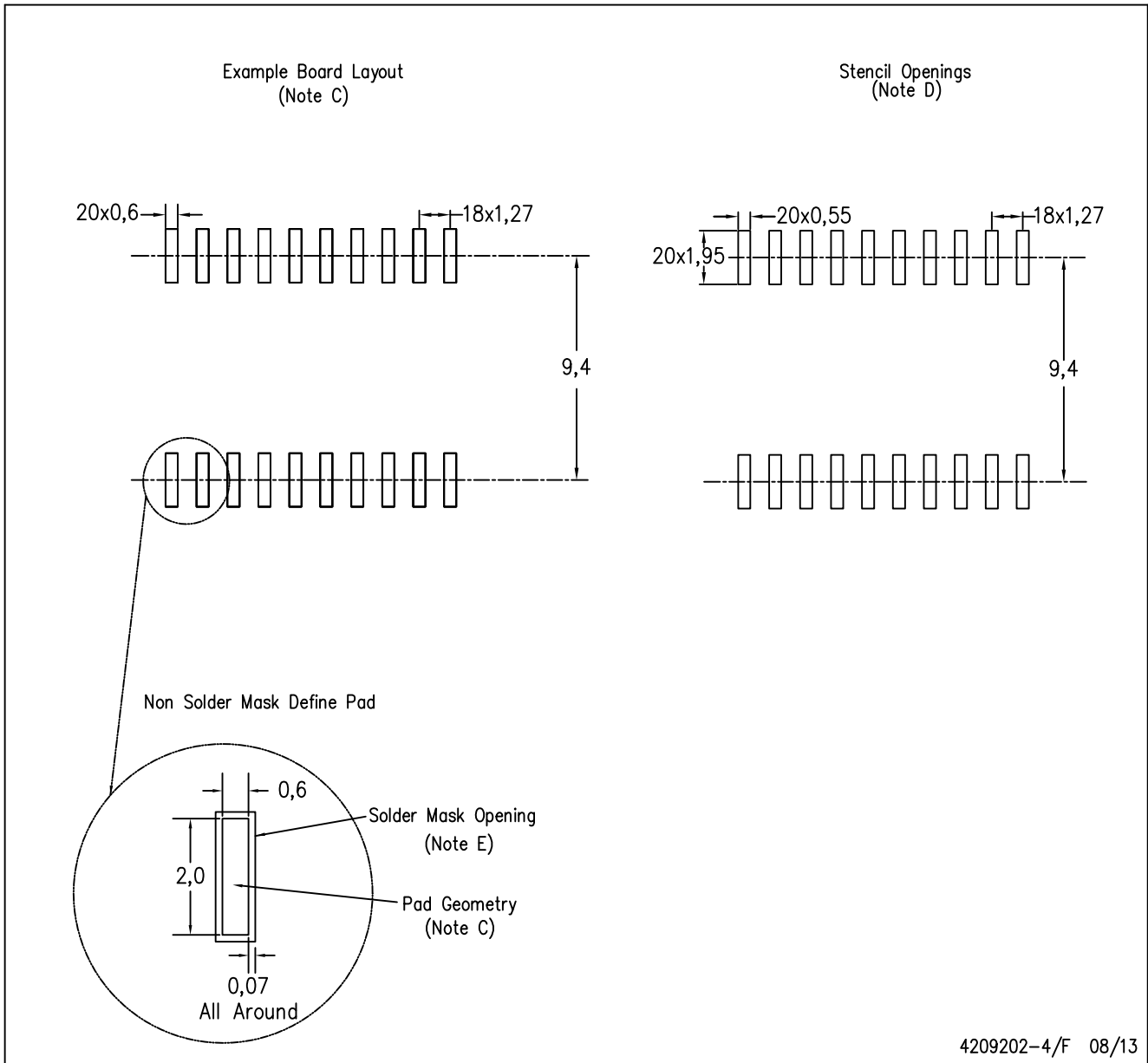

- NOTES:
- A. All linear dimensions are in millimeters.
  - B. This drawing is subject to change without notice.
  - C. Refer to IPC7351 for alternate board design.
  - D. Laser cutting apertures with trapezoidal walls and also rounding corners will offer better paste release. Customers should contact their board assembly site for stencil design recommendations. Refer to IPC-7525
  - E. Customers should contact their board fabrication site for solder mask tolerances between and around signal pads.

## IMPORTANT NOTICE

Texas Instruments Incorporated and its subsidiaries (TI) reserve the right to make corrections, enhancements, improvements and other changes to its semiconductor products and services per JESD46, latest issue, and to discontinue any product or service per JESD48, latest issue. Buyers should obtain the latest relevant information before placing orders and should verify that such information is current and complete. All semiconductor products (also referred to herein as "components") are sold subject to TI's terms and conditions of sale supplied at the time of order acknowledgment.

TI warrants performance of its components to the specifications applicable at the time of sale, in accordance with the warranty in TI's terms and conditions of sale of semiconductor products. Testing and other quality control techniques are used to the extent TI deems necessary to support this warranty. Except where mandated by applicable law, testing of all parameters of each component is not necessarily performed.

TI assumes no liability for applications assistance or the design of Buyers' products. Buyers are responsible for their products and applications using TI components. To minimize the risks associated with Buyers' products and applications, Buyers should provide adequate design and operating safeguards.

TI does not warrant or represent that any license, either express or implied, is granted under any patent right, copyright, mask work right, or other intellectual property right relating to any combination, machine, or process in which TI components or services are used. Information published by TI regarding third-party products or services does not constitute a license to use such products or services or a warranty or endorsement thereof. Use of such information may require a license from a third party under the patents or other intellectual property of the third party, or a license from TI under the patents or other intellectual property of TI.

Reproduction of significant portions of TI information in TI data books or data sheets is permissible only if reproduction is without alteration and is accompanied by all associated warranties, conditions, limitations, and notices. TI is not responsible or liable for such altered documentation. Information of third parties may be subject to additional restrictions.

Resale of TI components or services with statements different from or beyond the parameters stated by TI for that component or service voids all express and any implied warranties for the associated TI component or service and is an unfair and deceptive business practice. TI is not responsible or liable for any such statements.

Buyer acknowledges and agrees that it is solely responsible for compliance with all legal, regulatory and safety-related requirements concerning its products, and any use of TI components in its applications, notwithstanding any applications-related information or support that may be provided by TI. Buyer represents and agrees that it has all the necessary expertise to create and implement safeguards which anticipate dangerous consequences of failures, monitor failures and their consequences, lessen the likelihood of failures that might cause harm and take appropriate remedial actions. Buyer will fully indemnify TI and its representatives against any damages arising out of the use of any TI components in safety-critical applications.

In some cases, TI components may be promoted specifically to facilitate safety-related applications. With such components, TI's goal is to help enable customers to design and create their own end-product solutions that meet applicable functional safety standards and requirements. Nonetheless, such components are subject to these terms.

No TI components are authorized for use in FDA Class III (or similar life-critical medical equipment) unless authorized officers of the parties have executed a special agreement specifically governing such use.

Only those TI components which TI has specifically designated as military grade or "enhanced plastic" are designed and intended for use in military/aerospace applications or environments. Buyer acknowledges and agrees that any military or aerospace use of TI components which have **not** been so designated is solely at the Buyer's risk, and that Buyer is solely responsible for compliance with all legal and regulatory requirements in connection with such use.

TI has specifically designated certain components as meeting ISO/TS16949 requirements, mainly for automotive use. In any case of use of non-designated products, TI will not be responsible for any failure to meet ISO/TS16949.

### Products

Audio	<a href="http://www.ti.com/audio">www.ti.com/audio</a>
Amplifiers	<a href="http://amplifier.ti.com">amplifier.ti.com</a>
Data Converters	<a href="http://dataconverter.ti.com">dataconverter.ti.com</a>
DLP® Products	<a href="http://www.dlp.com">www.dlp.com</a>
DSP	<a href="http://dsp.ti.com">dsp.ti.com</a>
Clocks and Timers	<a href="http://www.ti.com/clocks">www.ti.com/clocks</a>
Interface	<a href="http://interface.ti.com">interface.ti.com</a>
Logic	<a href="http://logic.ti.com">logic.ti.com</a>
Power Mgmt	<a href="http://power.ti.com">power.ti.com</a>
Microcontrollers	<a href="http://microcontroller.ti.com">microcontroller.ti.com</a>
RFID	<a href="http://www.ti-rfid.com">www.ti-rfid.com</a>
OMAP Applications Processors	<a href="http://www.ti.com/omap">www.ti.com/omap</a>
Wireless Connectivity	<a href="http://www.ti.com/wirelessconnectivity">www.ti.com/wirelessconnectivity</a>

### Applications

Automotive and Transportation	<a href="http://www.ti.com/automotive">www.ti.com/automotive</a>
Communications and Telecom	<a href="http://www.ti.com/communications">www.ti.com/communications</a>
Computers and Peripherals	<a href="http://www.ti.com/computers">www.ti.com/computers</a>
Consumer Electronics	<a href="http://www.ti.com/consumer-apps">www.ti.com/consumer-apps</a>
Energy and Lighting	<a href="http://www.ti.com/energy">www.ti.com/energy</a>
Industrial	<a href="http://www.ti.com/industrial">www.ti.com/industrial</a>
Medical	<a href="http://www.ti.com/medical">www.ti.com/medical</a>
Security	<a href="http://www.ti.com/security">www.ti.com/security</a>
Space, Avionics and Defense	<a href="http://www.ti.com/space-avionics-defense">www.ti.com/space-avionics-defense</a>
Video and Imaging	<a href="http://www.ti.com/video">www.ti.com/video</a>

### TI E2E Community

[e2e.ti.com](http://e2e.ti.com)