

# SN75C185 LOW-POWER MULTIPLE DRIVERS AND RECEIVERS

SLLS065F – AUGUST 1989 – REVISED JANUARY 2000

- Meets or Exceeds the Requirements of TIA/EIA-232-F and ITU Recommendation V.28
- Single Chip With Easy Interface Between UART and Serial-Port Connector
- Less Than 9-mW Power Consumption
- Wide Driver Supply Voltage . . . 4.5 V to 13.2 V
- Driver Output Slew Rate Limited to 30 V/ $\mu$ s Max
- Receiver Input Hysteresis . . . 1100 mV Typ
- Push-Pull Receiver Outputs
- On-Chip Receiver 1- $\mu$ s Noise Filter
- Functionally Interchangeable With Texas Instruments SN75185
- Operates Up to 120 kbit/s Over a 3-Meter Cable (See *Application Information for Conditions*)

DW OR N PACKAGE  
(TOP VIEW)

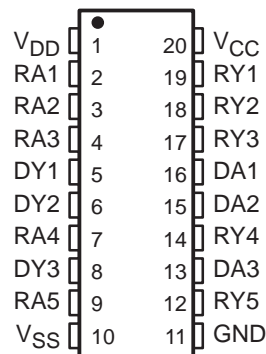

## description

The SN75C185 is a low-power BiMOS device containing three independent drivers and five receivers that are used to interface data terminal equipment (DTE) with data circuit-terminating equipment (DCE). Typically, the SN75C185 replaces one SN75188 and two SN75189 devices. This device conforms to TIA/EIA-232-F. The drivers and receivers of the SN75C185 are similar to those of the SN75C188 and SN75C189A, respectively. The drivers have a controlled output slew rate that is limited to a maximum of 30 V/ $\mu$ s, and the receivers have filters that reject input noise pulses that are shorter than 1  $\mu$ s. Both these features eliminate the need for external components.

The SN75C185 uses the low-power BiMOS technology. In most applications, the receivers contained in this device interface to single inputs of peripheral devices such as ACEs, UARTS, or microprocessors. By using sampling, such peripheral devices usually are insensitive to the transition times of the input signals. If this is not the case, or for other uses, it is recommended that the SN75C185 receiver outputs be buffered by single Schmitt input gates or single gates of the HCMOS, ALS, or 74F logic families.

The SN75C185 is characterized for operation from 0°C to 70°C.



Please be aware that an important notice concerning availability, standard warranty, and use in critical applications of Texas Instruments semiconductor products and disclaimers thereto appears at the end of this data sheet.

PRODUCTION DATA information is current as of publication date. Products conform to specifications per the terms of Texas Instruments standard warranty. Production processing does not necessarily include testing of all parameters.

 **TEXAS  
INSTRUMENTS**

POST OFFICE BOX 655303 • DALLAS, TEXAS 75265

Copyright © 2000, Texas Instruments Incorporated

# SN75C185

## LOW-POWER MULTIPLE DRIVERS AND RECEIVERS

SLLS065F – AUGUST 1989 – REVISED JANUARY 2000

### logic symbol†

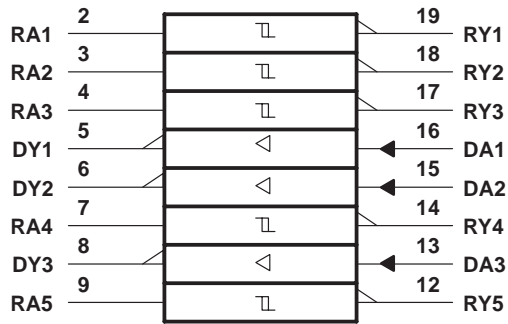

† This symbol is in accordance with ANSI/IEEE Std 91-1984 and IEC Publication 617-12.

### logic diagram (positive logic)

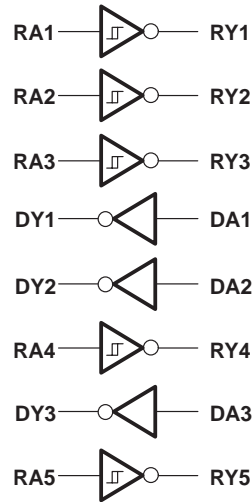

equivalent schematics of inputs and outputs

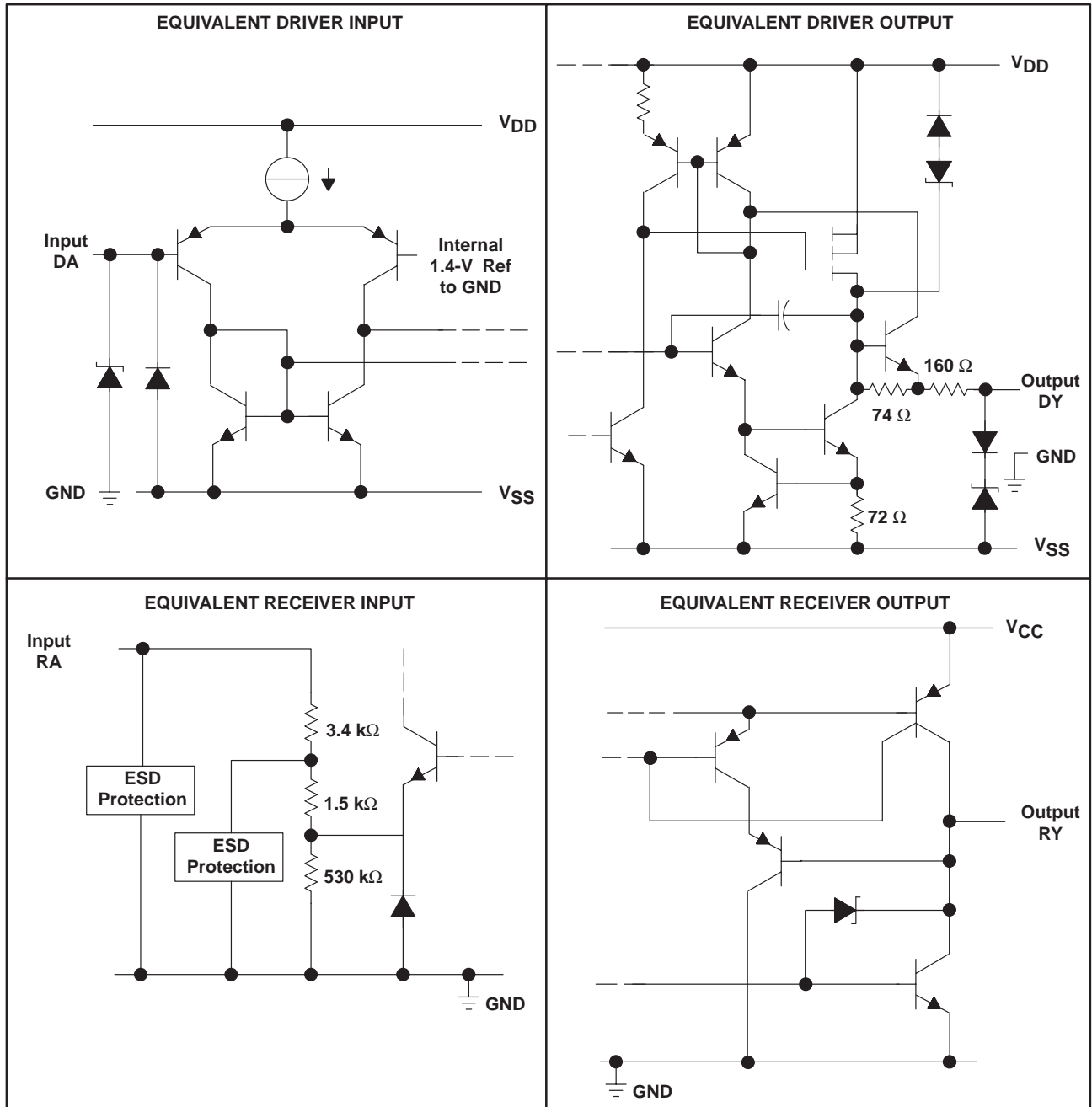

All resistor values are nominal.

# SN75C185

## LOW-POWER MULTIPLE DRIVERS AND RECEIVERS

SLLS065F – AUGUST 1989 – REVISED JANUARY 2000

### absolute maximum ratings over operating free-air temperature range (unless otherwise noted)†

Supply voltage, $V_{DD}$ (see Note 1)	13.5 V
Supply voltage, $V_{SS}$	-13.5 V
Supply voltage, $V_{CC}$	7 V
Input voltage range, $V_I$ : Driver	$V_{SS}$ to $V_{DD}$
Receiver	-30 V to 30 V
Output voltage range, $V_O$ : Driver	$V_{SS} - 6$ V to $V_{DD} + 6$ V
Receiver	-0.3 V to $V_{CC} + 0.3$ V
Package thermal impedance, $\theta_{JA}$ (see Note 2): DW package	58°C/W
N package	69°C/W
Operating free-air temperature range, $T_A$	0°C to 70°C
Lead temperature 1,6 mm (1/16 inch) from case for 10 seconds	260°C
Storage temperature range, $T_{stg}$	-65°C to 150°C

† Stresses beyond those listed under “absolute maximum ratings” may cause permanent damage to the device. These are stress ratings only, and functional operation of the device at these or any other conditions beyond those indicated under “recommended operating conditions” is not implied. Exposure to absolute-maximum-rated conditions for extended periods may affect device reliability.

- NOTES: 1. All voltages are with respect to network GND.  
 2. The package thermal impedance is calculated in accordance with JESD 51.

### recommended operating conditions

		MIN	NOM	MAX	UNIT
Supply voltage	$V_{DD}$	4.5	12	13.2	V
	$V_{SS}$	-4.5	-12	-13.2	V
	$V_{CC}$	4.5	5	6	V
$V_I$ Input voltage (see Note 3)	Drivers	$V_{SS} + 2$		$V_{DD}$	V
	Receivers	-25		25	V
$V_{IH}$ High-level input voltage	Drivers	2			V
$V_{IL}$ Low-level input voltage				0.8	V
$I_{OH}$ High-level output current	Receivers			-1	mA
$I_{OL}$ High-level output current				3.2	mA
$T_A$ Operating free-air temperature			0	70	°C

NOTE 3: The algebraic convention, where the more positive (less negative) limit is designated as maximum, is used in this data sheet for logic levels only, e.g., if -10 V is a maximum, the typical value is a more negative voltage.

### supply currents

PARAMETER	TEST CONDITIONS	MIN	TYP	MAX	UNIT
$I_{DD}$ Supply current from $V_{DD}$	No load, All inputs at 2 V or 0.8 V	$V_{DD} = 5$ V, $V_{SS} = -5$ V	115	200	$\mu$ A
		$V_{DD} = 12$ V, $V_{SS} = -12$ V	115	200	
$I_{SS}$ Supply current from $V_{SS}$	No load, All inputs at 2 V or 0.8 V	$V_{DD} = 5$ V, $V_{SS} = -5$ V	-115	-200	$\mu$ A
		$V_{DD} = 12$ V, $V_{SS} = -12$ V	-115	-200	
$I_{CC}$ Supply current from $V_{CC}$	No load All inputs at 0 or 5 V	$V_{DD} = 5$ V, $V_{SS} = -5$ V		750	$\mu$ A
		$V_{DD} = 12$ V, $V_{SS} = -12$ V		750	



### DRIVER SECTION

**electrical characteristics over operating free-air temperature range,  $V_{DD} = 12\text{ V}$ ,  $V_{SS} = -12\text{ V}$ ,  $V_{CC} = 5\text{ V} \pm 10\%$  (unless otherwise noted)**

PARAMETER		TEST CONDITIONS		MIN	TYP†	MAX	UNIT
$V_{OH}$	High-level output voltage	$V_{IL} = 0.8\text{ V}$ , See Figure 1	$R_L = 3\text{ k}\Omega$ ,	$V_{DD} = 5\text{ V}$ , $V_{SS} = -5\text{ V}$	4	4.5	V
				$V_{DD} = 12\text{ V}$ $V_{SS} = -12\text{ V}$	10	10.8	
$V_{OL}$	Low-level output voltage (see Note 3)	$V_{IH} = 0.8\text{ V}$ , See Figure 1	$R_L = 3\text{ k}\Omega$ ,	$V_{DD} = 5\text{ V}$ , $V_{SS} = -5\text{ V}$	-4.4	-4	V
				$V_{DD} = 12\text{ V}$ $V_{SS} = -12\text{ V}$	-10.7	-10	
$I_{IH}$	High-level input current	$V_I = 5\text{ V}$ ,	See Figure 2			1	$\mu\text{A}$
$I_{IL}$	Low-level input current	$V_I = 0$ ,	See Figure 2			-1	$\mu\text{A}$
$I_{OS(H)}$	High-level short-circuit output current (see Note 4)	$V_I = 0.8\text{ V}$ , See Figure 1	$V_O = 0$ or $V_O = V_{SS}$ ,	-4.5	-12	-19.5	mA
$I_{OS(L)}$	Low-level short-circuit output current (see Note 4)	$V_I = 2\text{ V}$ , See Figure 1	$V_O = 0$ or $V_O = V_{DD}$ ,	4.5	12	19.5	mA
$r_o$	Output resistance	$V_{DD} = V_{SS} = V_{CC} = 0$ , See Note 5		$V_O = -2\text{ V}$ to $2\text{ V}$ ,	300	400	$\Omega$

† All typical values are at  $T_A = 25^\circ\text{C}$ .

- NOTES: 3. The algebraic convention, where the more positive (less negative) limit is designated as maximum, is used in this data sheet for logic levels only, e.g., if  $-10\text{ V}$  is a maximum, the typical value is a more negative voltage.
4. Not more than one output should be shorted at one time.
5. Test conditions are those specified by TIA/EIA-232-F.

**switching characteristics,  $V_{DD} = 12\text{ V}$ ,  $V_{SS} = -12\text{ V}$ ,  $V_{CC} = 5\text{ V} \pm 10\%$ ,  $T_A = 25^\circ\text{C}$  (unless otherwise noted) (see Figure 3)**

PARAMETER		TEST CONDITIONS		MIN	TYP	MAX	UNIT	
$t_{PLH}$	Propagation delay time, low- to high-level output (see Note 6)	$R_L = 3\text{ k}\Omega$ to $7\text{ k}\Omega$ , $C_L = 15\text{ pF}$			1.2	3	$\mu\text{s}$	
$t_{PHL}$	Propagation delay time, high- to low-level output (see Note 6)				2.5	3.5	$\mu\text{s}$	
$t_{TLH}$	Transition time, low- to high-level output				0.53	2	3.2	$\mu\text{s}$
$t_{THL}$	Transition time, high- to low-level output				0.53	2	3.2	$\mu\text{s}$
$t_{TLH}$	Transition time, low- to high-level output (see Note 7)	$R_L = 3\text{ k}\Omega$ to $7\text{ k}\Omega$ , $C_L = 2500\text{ pF}$			1		$\mu\text{s}$	
$t_{THL}$	Transition time, high- to low-level output (see Note 7)				1		$\mu\text{s}$	
$S_R$	Output slew rate (see Note 7)	$R_L = 3\text{ k}\Omega$ to $7\text{ k}\Omega$ , $C_L = 15\text{ pF}$		4	10	30	$\text{V}/\mu\text{s}$	

- NOTES: 6.  $t_{PHL}$  and  $t_{PLH}$  include the additional time due to on-chip slew rate and are measured at the 50% points.
7. Measured between  $3\text{-V}$  and  $-3\text{-V}$  points of output waveform (TIA/EIA-232-F conditions), and all unused inputs are tied either high or low.

# SN75C185

## LOW-POWER MULTIPLE DRIVERS AND RECEIVERS

SLLS065F – AUGUST 1989 – REVISED JANUARY 2000

### RECEIVER SECTION

electrical characteristics over operating free-air temperature range,  $V_{DD} = 12\text{ V}$ ,  $V_{SS} = -12\text{ V}$ ,  $V_{CC} = 5\text{ V} \pm 10\%$  (unless otherwise noted)

PARAMETER		TEST CONDITIONS	MIN	TYP†	MAX	UNIT
$V_{IT+}$	Positive-going input threshold voltage	See Figure 5	1.6	2.1	2.55	V
$V_{IT-}$	Negative-going input threshold voltage	See Figure 5	0.65	1	1.25	V
$V_{hys}$	Input hysteresis voltage ( $V_{IT+} - V_{IT-}$ )		600	1100		mV
$V_{OH}$	High-level output voltage	$V_I = 0.75\text{ V}$ , $I_{OH} = -20\text{ }\mu\text{A}$ , See Figure 5 and Note 8	3.5			V
		$V_I = 0.75\text{ V}$ , $I_{OH} = -1\text{ mA}$ , See Figure 5	2.8	4.4		
		$V_{CC} = 4.5\text{ V}$ $V_{CC} = 5\text{ V}$ $V_{CC} = 5.5\text{ V}$	3.8	4.9	4.3	
$V_{OL}$	Low-level output voltage	$V_I = 3\text{ V}$ , $I_{OL} = 3.2\text{ mA}$ , See Figure 5		0.17	0.4	V
$I_{IH}$	High-level input current	$V_I = 3\text{ V}$	0.43	0.55	1	mA
		$V_I = 25\text{ V}$	3.6	4.6	8.3	
$I_{IL}$	Low-level input current	$V_I = -3\text{ V}$	-0.43	-0.55	-1	mA
		$V_I = -25\text{ V}$	-3.6	-5.0	-8.3	
$I_{OS(H)}$	Short-circuit output at high level	$V_I = 0.75\text{ V}$ , $V_O = 0$ , See Figure 4		-8	-15	mA
$I_{OS(L)}$	Short-circuit output at low level	$V_I = V_{CC}$ , $V_O = V_{CC}$ , See Figure 4		13	25	mA

† All typical values are at  $T_A = 25^\circ\text{C}$ .

NOTE 8: If the inputs are left unconnected, the receiver interprets this as an input low, and the receiver outputs remain in the high state.

switching characteristics,  $V_{DD} = 12\text{ V}$ ,  $V_{SS} = -12\text{ V}$ ,  $V_{CC} = 5\text{ V} \pm 10\%$ ,  $T_A = 25^\circ\text{C}$  (unless otherwise noted) (see Figure 6)

PARAMETER		TEST CONDITIONS	MIN	TYP	MAX	UNIT
$t_{PLH}$	Propagation delay time, low- to high-level output	$R_L = 5\text{ k}\Omega$ , $C_L = 50\text{ pF}$		3	4	$\mu\text{s}$
$t_{PHL}$	Propagation delay time, high- to low-level output			3	4	$\mu\text{s}$
$t_{TLH}$	Transition time, low- to high-level output			300	450	ns
$t_{THL}$	Transition time, high- to low-level output			100	300	ns
$t_w(N)$	Duration of longest pulse rejected as noise (see Note 9)	$R_L = 5\text{ k}\Omega$ , $C_L = 50\text{ pF}$	1		4	$\mu\text{s}$

NOTE 9: The receiver ignores any positive- or negative-going pulse that is less than the minimum value of  $t_w(N)$  and accepts any positive- or negative-going pulse greater than the maximum of  $t_w(N)$ .



PARAMETER MEASUREMENT INFORMATION

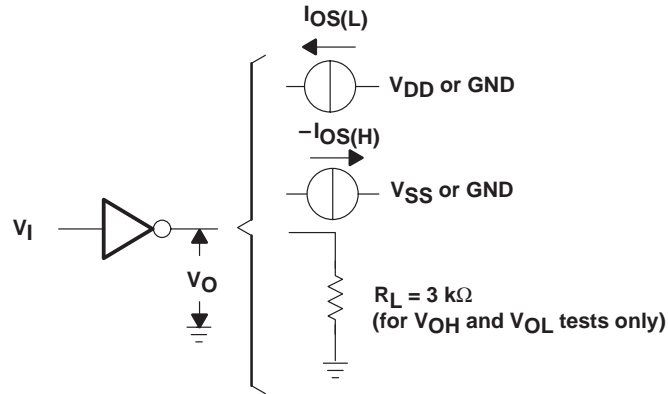

Figure 1. Driver Test Circuit for  $V_{OH}$ ,  $V_{OL}$ ,  $I_{OS(H)}$ , and  $I_{OS(L)}$

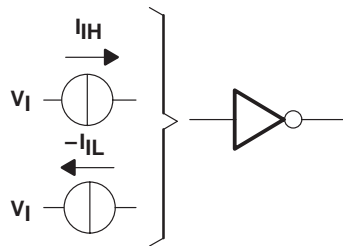
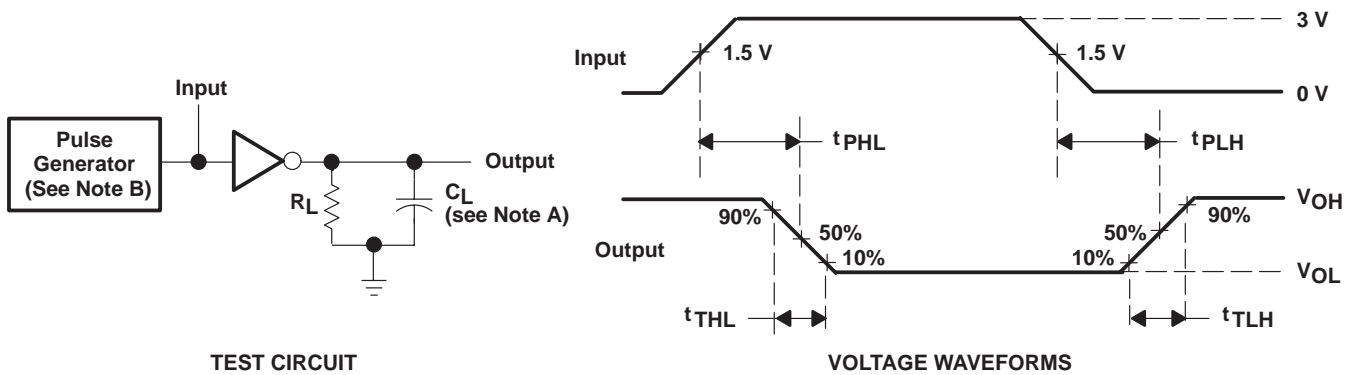

Figure 2. Driver Test Circuit for  $I_{IH}$  and  $I_{IL}$



- NOTES: A.  $C_L$  includes probe and jig capacitance.  
B. The pulse generator has the following characteristics:  $t_w = 25\ \mu\text{s}$ ,  $\text{PRR} = 20\ \text{kHz}$ ,  $Z_O = 50\ \Omega$ ,  $t_r = t_f < 50\ \text{ns}$ .

Figure 3. Driver Test Circuit and Voltage Waveforms

# SN75C185 LOW-POWER MULTIPLE DRIVERS AND RECEIVERS

SLLS065F – AUGUST 1989 – REVISED JANUARY 2000

## PARAMETER MEASUREMENT INFORMATION

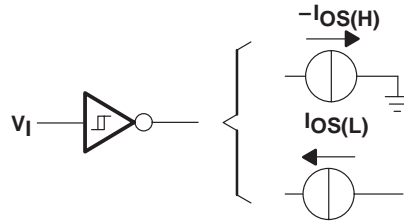

Figure 4. Receiver Test Circuit for  $I_{OS(H)}$  and  $I_{OS(L)}$

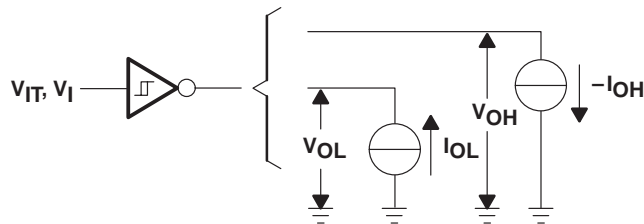
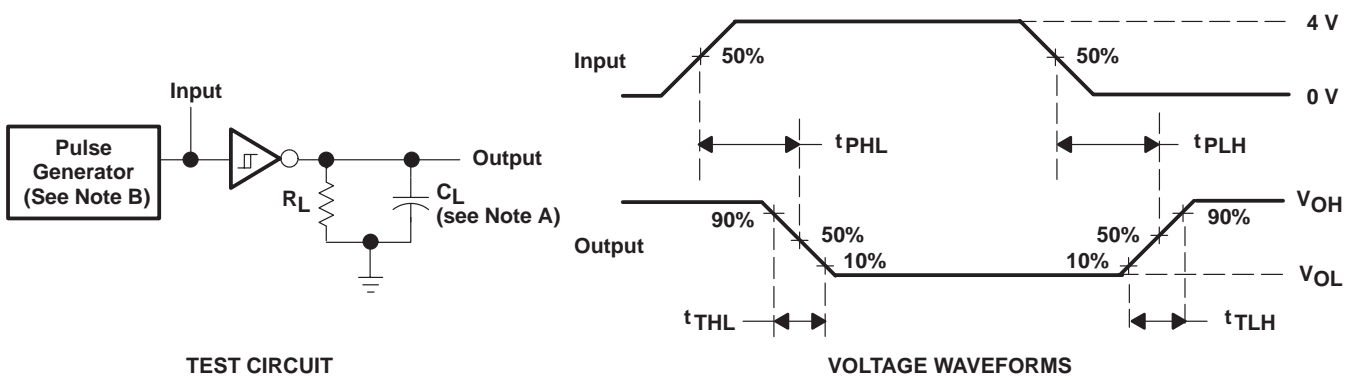

Figure 5. Receiver Test Circuit for  $V_{IT}$ ,  $V_{OH}$ , and  $V_{OL}$



NOTES: A.  $C_L$  includes probe and jig capacitance.

B. The pulse generator has the following characteristics:  $t_{WV} = 25 \mu s$ ,  $PRR = 20 \text{ kHz}$ ,  $Z_O = 50 \Omega$ ,  $t_r = t_f < 50 \text{ ns}$ .

Figure 6. Receiver Propagation and Transition Times

**APPLICATION INFORMATION**

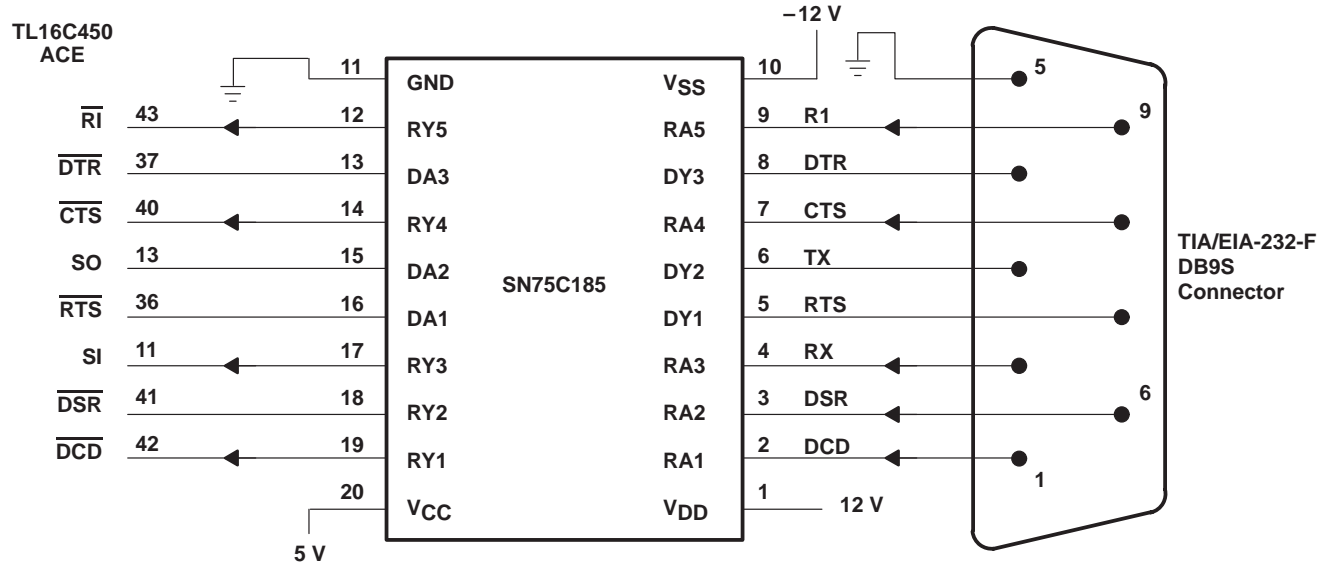

**Figure 7. Typical Connection**

The SN75C185 supports data rates up to 120 kbit/s over a 3-meter cable. Laboratory experiments show that, with  $C_L = 500$  pF and  $R_L = 3$  k $\Omega$  (minimum RS-232 input resistance load), the device can support this data rate. The 500-pF load approximates a typical 3-meter cable because the maximum RS-232 specification is 2500 pF (or about 15 meters). Figure 8 shows the test circuit used. Temperature was varied from 0°C to 70°C for the experiment.

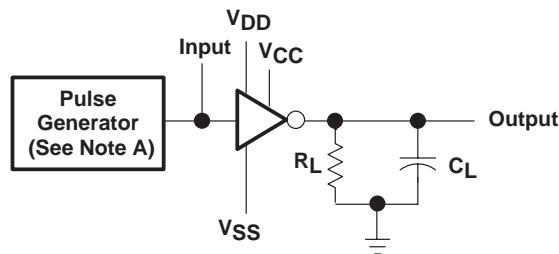

- NOTES: A. The pulse generator has the following characteristics: PRR = 60 kHz (120 kbit/s),  $Z_O = 50 \Omega$ .  
B.  $V_{CC} = 5$  V,  $V_{DD} = 12$  V,  $V_{SS} = -12$  V.

**Figure 8. Data-Rate Test Circuit**

**PACKAGING INFORMATION**

Orderable Device	Status (1)	Package Type	Package Drawing	Pins	Package Qty	Eco Plan (2)	Lead/Ball Finish (6)	MSL Peak Temp (3)	Op Temp (°C)	Device Marking (4/5)	Samples
SN75C185DW	ACTIVE	SOIC	DW	20	25	Green (RoHS & no Sb/Br)	CU NIPDAU	Level-1-260C-UNLIM	0 to 70	SN75C185	<a href="#">Samples</a>
SN75C185DWG4	ACTIVE	SOIC	DW	20	25	Green (RoHS & no Sb/Br)	CU NIPDAU	Level-1-260C-UNLIM	0 to 70	SN75C185	<a href="#">Samples</a>
SN75C185DWR	ACTIVE	SOIC	DW	20	2000	Green (RoHS & no Sb/Br)	CU NIPDAU	Level-1-260C-UNLIM	0 to 70	SN75C185	<a href="#">Samples</a>
SN75C185N	ACTIVE	PDIP	N	20	20	Pb-Free (RoHS)	CU NIPDAU	N / A for Pkg Type	0 to 70	SN75C185N	<a href="#">Samples</a>
SN75C185NE4	ACTIVE	PDIP	N	20	20	Pb-Free (RoHS)	CU NIPDAU	N / A for Pkg Type	0 to 70	SN75C185N	<a href="#">Samples</a>

(1) The marketing status values are defined as follows:

**ACTIVE:** Product device recommended for new designs.

**LIFEBUY:** TI has announced that the device will be discontinued, and a lifetime-buy period is in effect.

**NRND:** Not recommended for new designs. Device is in production to support existing customers, but TI does not recommend using this part in a new design.

**PREVIEW:** Device has been announced but is not in production. Samples may or may not be available.

**OBSELETE:** TI has discontinued the production of the device.

(2) Eco Plan - The planned eco-friendly classification: Pb-Free (RoHS), Pb-Free (RoHS Exempt), or Green (RoHS & no Sb/Br) - please check <http://www.ti.com/productcontent> for the latest availability information and additional product content details.

**TBD:** The Pb-Free/Green conversion plan has not been defined.

**Pb-Free (RoHS):** TI's terms "Lead-Free" or "Pb-Free" mean semiconductor products that are compatible with the current RoHS requirements for all 6 substances, including the requirement that lead not exceed 0.1% by weight in homogeneous materials. Where designed to be soldered at high temperatures, TI Pb-Free products are suitable for use in specified lead-free processes.

**Pb-Free (RoHS Exempt):** This component has a RoHS exemption for either 1) lead-based flip-chip solder bumps used between the die and package, or 2) lead-based die adhesive used between the die and leadframe. The component is otherwise considered Pb-Free (RoHS compatible) as defined above.

**Green (RoHS & no Sb/Br):** TI defines "Green" to mean Pb-Free (RoHS compatible), and free of Bromine (Br) and Antimony (Sb) based flame retardants (Br or Sb do not exceed 0.1% by weight in homogeneous material)

(3) MSL, Peak Temp. - The Moisture Sensitivity Level rating according to the JEDEC industry standard classifications, and peak solder temperature.

(4) There may be additional marking, which relates to the logo, the lot trace code information, or the environmental category on the device.

(5) Multiple Device Markings will be inside parentheses. Only one Device Marking contained in parentheses and separated by a "~" will appear on a device. If a line is indented then it is a continuation of the previous line and the two combined represent the entire Device Marking for that device.

<sup>(6)</sup> Lead/Ball Finish - Orderable Devices may have multiple material finish options. Finish options are separated by a vertical ruled line. Lead/Ball Finish values may wrap to two lines if the finish value exceeds the maximum column width.

**Important Information and Disclaimer:**The information provided on this page represents TI's knowledge and belief as of the date that it is provided. TI bases its knowledge and belief on information provided by third parties, and makes no representation or warranty as to the accuracy of such information. Efforts are underway to better integrate information from third parties. TI has taken and continues to take reasonable steps to provide representative and accurate information but may not have conducted destructive testing or chemical analysis on incoming materials and chemicals. TI and TI suppliers consider certain information to be proprietary, and thus CAS numbers and other limited information may not be available for release.

In no event shall TI's liability arising out of such information exceed the total purchase price of the TI part(s) at issue in this document sold by TI to Customer on an annual basis.

## TAPE AND REEL INFORMATION



### QUADRANT ASSIGNMENTS FOR PIN 1 ORIENTATION IN TAPE



\*All dimensions are nominal

Device	Package Type	Package Drawing	Pins	SPQ	Reel Diameter (mm)	Reel Width W1 (mm)	A0 (mm)	B0 (mm)	K0 (mm)	P1 (mm)	W (mm)	Pin1 Quadrant
SN75C185DWR	SOIC	DW	20	2000	330.0	24.4	10.8	13.3	2.7	12.0	24.0	Q1

TAPE AND REEL BOX DIMENSIONS



\*All dimensions are nominal

Device	Package Type	Package Drawing	Pins	SPQ	Length (mm)	Width (mm)	Height (mm)
SN75C185DWR	SOIC	DW	20	2000	367.0	367.0	45.0

N (R-PDIP-T\*\*)

PLASTIC DUAL-IN-LINE PACKAGE

16 PINS SHOWN



- NOTES:
- A. All linear dimensions are in inches (millimeters).
  - B. This drawing is subject to change without notice.
  - C. Falls within JEDEC MS-001, except 18 and 20 pin minimum body length (Dim A).
  - D. The 20 pin end lead shoulder width is a vendor option, either half or full width.

DW (R-PDSO-G20)

PLASTIC SMALL OUTLINE



- NOTES:
- A. All linear dimensions are in inches (millimeters). Dimensioning and tolerancing per ASME Y14.5M-1994.
  - B. This drawing is subject to change without notice.
  - C. Body dimensions do not include mold flash or protrusion not to exceed 0.006 (0,15).
  - D. Falls within JEDEC MS-013 variation AC.

DW (R-PDSO-G20)

PLASTIC SMALL OUTLINE

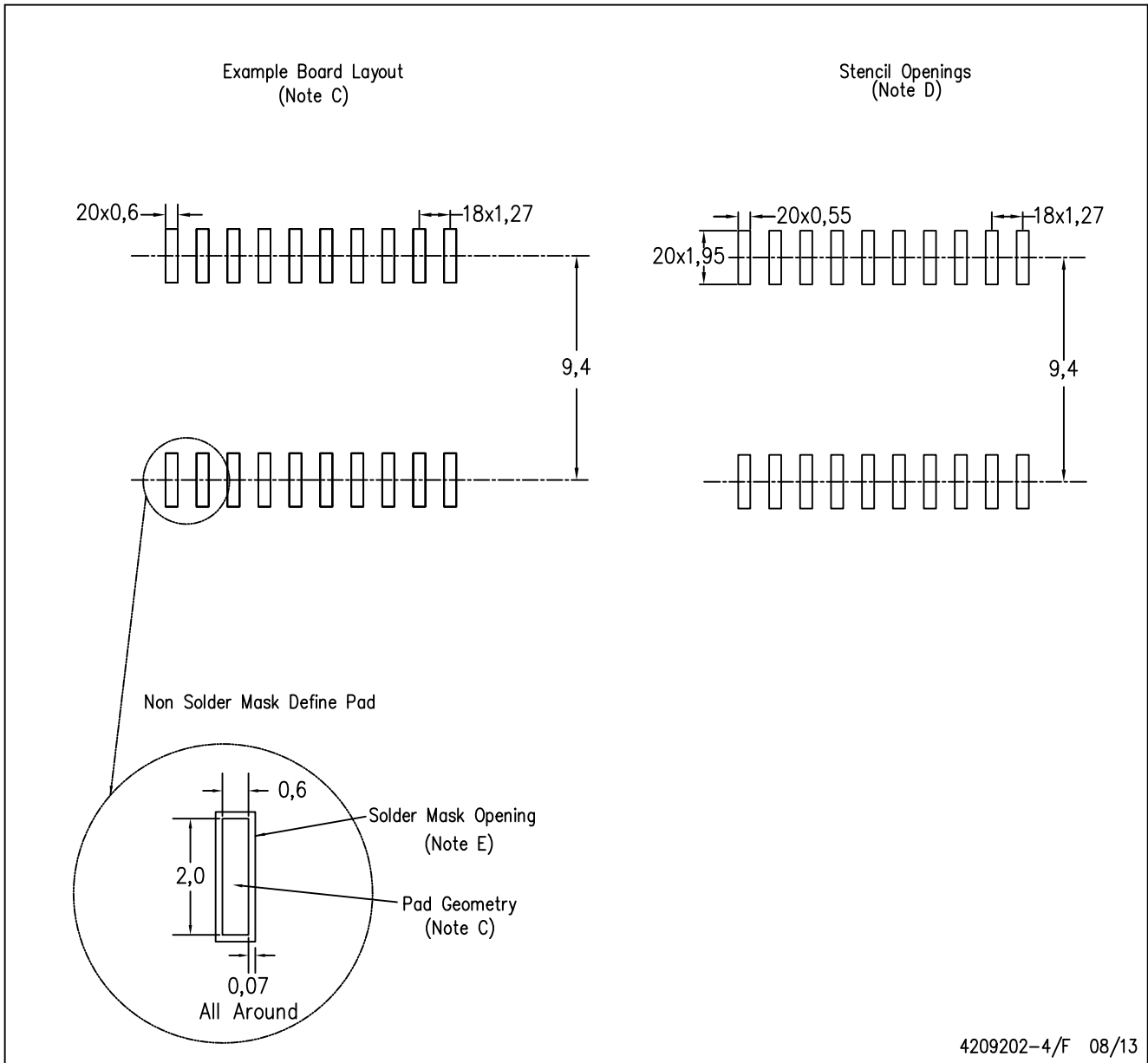

4209202-4/F 08/13

- NOTES:
- A. All linear dimensions are in millimeters.
  - B. This drawing is subject to change without notice.
  - C. Refer to IPC7351 for alternate board design.
  - D. Laser cutting apertures with trapezoidal walls and also rounding corners will offer better paste release. Customers should contact their board assembly site for stencil design recommendations. Refer to IPC-7525
  - E. Customers should contact their board fabrication site for solder mask tolerances between and around signal pads.

## IMPORTANT NOTICE

Texas Instruments Incorporated and its subsidiaries (TI) reserve the right to make corrections, enhancements, improvements and other changes to its semiconductor products and services per JESD46, latest issue, and to discontinue any product or service per JESD48, latest issue. Buyers should obtain the latest relevant information before placing orders and should verify that such information is current and complete. All semiconductor products (also referred to herein as "components") are sold subject to TI's terms and conditions of sale supplied at the time of order acknowledgment.

TI warrants performance of its components to the specifications applicable at the time of sale, in accordance with the warranty in TI's terms and conditions of sale of semiconductor products. Testing and other quality control techniques are used to the extent TI deems necessary to support this warranty. Except where mandated by applicable law, testing of all parameters of each component is not necessarily performed.

TI assumes no liability for applications assistance or the design of Buyers' products. Buyers are responsible for their products and applications using TI components. To minimize the risks associated with Buyers' products and applications, Buyers should provide adequate design and operating safeguards.

TI does not warrant or represent that any license, either express or implied, is granted under any patent right, copyright, mask work right, or other intellectual property right relating to any combination, machine, or process in which TI components or services are used. Information published by TI regarding third-party products or services does not constitute a license to use such products or services or a warranty or endorsement thereof. Use of such information may require a license from a third party under the patents or other intellectual property of the third party, or a license from TI under the patents or other intellectual property of TI.

Reproduction of significant portions of TI information in TI data books or data sheets is permissible only if reproduction is without alteration and is accompanied by all associated warranties, conditions, limitations, and notices. TI is not responsible or liable for such altered documentation. Information of third parties may be subject to additional restrictions.

Resale of TI components or services with statements different from or beyond the parameters stated by TI for that component or service voids all express and any implied warranties for the associated TI component or service and is an unfair and deceptive business practice. TI is not responsible or liable for any such statements.

Buyer acknowledges and agrees that it is solely responsible for compliance with all legal, regulatory and safety-related requirements concerning its products, and any use of TI components in its applications, notwithstanding any applications-related information or support that may be provided by TI. Buyer represents and agrees that it has all the necessary expertise to create and implement safeguards which anticipate dangerous consequences of failures, monitor failures and their consequences, lessen the likelihood of failures that might cause harm and take appropriate remedial actions. Buyer will fully indemnify TI and its representatives against any damages arising out of the use of any TI components in safety-critical applications.

In some cases, TI components may be promoted specifically to facilitate safety-related applications. With such components, TI's goal is to help enable customers to design and create their own end-product solutions that meet applicable functional safety standards and requirements. Nonetheless, such components are subject to these terms.

No TI components are authorized for use in FDA Class III (or similar life-critical medical equipment) unless authorized officers of the parties have executed a special agreement specifically governing such use.

Only those TI components which TI has specifically designated as military grade or "enhanced plastic" are designed and intended for use in military/aerospace applications or environments. Buyer acknowledges and agrees that any military or aerospace use of TI components which have **not** been so designated is solely at the Buyer's risk, and that Buyer is solely responsible for compliance with all legal and regulatory requirements in connection with such use.

TI has specifically designated certain components as meeting ISO/TS16949 requirements, mainly for automotive use. In any case of use of non-designated products, TI will not be responsible for any failure to meet ISO/TS16949.

### Products

Audio	<a href="http://www.ti.com/audio">www.ti.com/audio</a>
Amplifiers	<a href="http://amplifier.ti.com">amplifier.ti.com</a>
Data Converters	<a href="http://dataconverter.ti.com">dataconverter.ti.com</a>
DLP® Products	<a href="http://www.dlp.com">www.dlp.com</a>
DSP	<a href="http://dsp.ti.com">dsp.ti.com</a>
Clocks and Timers	<a href="http://www.ti.com/clocks">www.ti.com/clocks</a>
Interface	<a href="http://interface.ti.com">interface.ti.com</a>
Logic	<a href="http://logic.ti.com">logic.ti.com</a>
Power Mgmt	<a href="http://power.ti.com">power.ti.com</a>
Microcontrollers	<a href="http://microcontroller.ti.com">microcontroller.ti.com</a>
RFID	<a href="http://www.ti-rfid.com">www.ti-rfid.com</a>
OMAP Applications Processors	<a href="http://www.ti.com/omap">www.ti.com/omap</a>
Wireless Connectivity	<a href="http://www.ti.com/wirelessconnectivity">www.ti.com/wirelessconnectivity</a>

### Applications

Automotive and Transportation	<a href="http://www.ti.com/automotive">www.ti.com/automotive</a>
Communications and Telecom	<a href="http://www.ti.com/communications">www.ti.com/communications</a>
Computers and Peripherals	<a href="http://www.ti.com/computers">www.ti.com/computers</a>
Consumer Electronics	<a href="http://www.ti.com/consumer-apps">www.ti.com/consumer-apps</a>
Energy and Lighting	<a href="http://www.ti.com/energy">www.ti.com/energy</a>
Industrial	<a href="http://www.ti.com/industrial">www.ti.com/industrial</a>
Medical	<a href="http://www.ti.com/medical">www.ti.com/medical</a>
Security	<a href="http://www.ti.com/security">www.ti.com/security</a>
Space, Avionics and Defense	<a href="http://www.ti.com/space-avionics-defense">www.ti.com/space-avionics-defense</a>
Video and Imaging	<a href="http://www.ti.com/video">www.ti.com/video</a>

### TI E2E Community

[e2e.ti.com](http://e2e.ti.com)