

SN75C188 QUADRUPLE LOW-POWER LINE DRIVERS

SLLS033F – JANUARY 1988 – REVISED MARCH 1997

- **Bi-MOS Technology With TTL and CMOS Compatibility**
- **Meets or Exceeds the Requirements of ANSI EIA/TIA-232-E and ITU Recommendation V.28**
- **Very Low Quiescent Current . . . 95 μ A Typ**
 $V_{CC\pm} = \pm 12$ V
- **Current-Limited Outputs . . . 10 mA Typ**
- **CMOS- and TTL-Compatible Inputs**
- **On-Chip Slew Rate Limited to 30 V/ μ s max**
- **Flexible Supply Voltage Range**
- **Characterized at $V_{CC\pm}$ of ± 4.5 V and ± 15 V**
- **Functionally Interchangeable With Texas Instruments SN75188, Motorola MC1488, and National Semiconductor DS14C88**

**D, DB†, OR N PACKAGE
(TOP VIEW)**

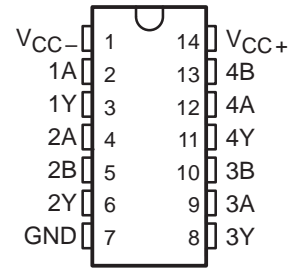

† The DB package is only available left-end taped and reeled, i.e., order device SN75C188DBLE.

description

The SN75C188 is a monolithic, low-power, quadruple line driver that interfaces data terminal equipment with data communications equipment. This device is designed to conform to ANSI Standard EIA/TIA-232-E.

An external diode in series with each supply-voltage terminal is needed to protect the SN75C188 under certain fault conditions to comply with EIA/TIA-232-E.

The SN75C188 is characterized for operation from 0°C to 70°C.

Function Tables

DRIVER 1

B	Y
H	L
L	H

DRIVERS 2 – 4

A	B	Y
H	H	L
L	X	H
X	L	H

H = high level, L = low level,
X = don't care

SN75C188 QUADRUPLE LOW-POWER LINE DRIVERS

SLLS033F – JANUARY 1988 – REVISED MARCH 1997

logic symbol†

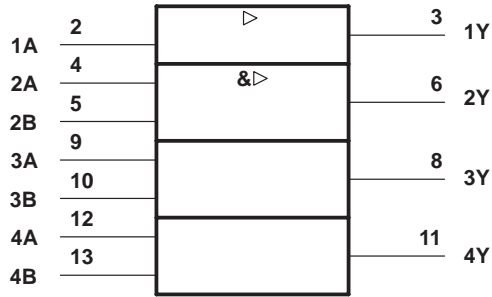

† This symbol is in accordance with ANSI/IEEE Std 91-1984 and IEC Publication 617-12.

logic diagram (positive logic)

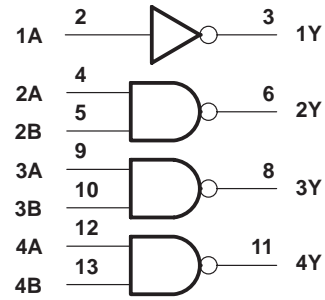

positive logic
 $Y = \bar{A}$ (driver 1)
 $Y = \overline{AB}$ or $\bar{A} + \bar{B}$ (drivers 2 through 4)

schematics of inputs and outputs

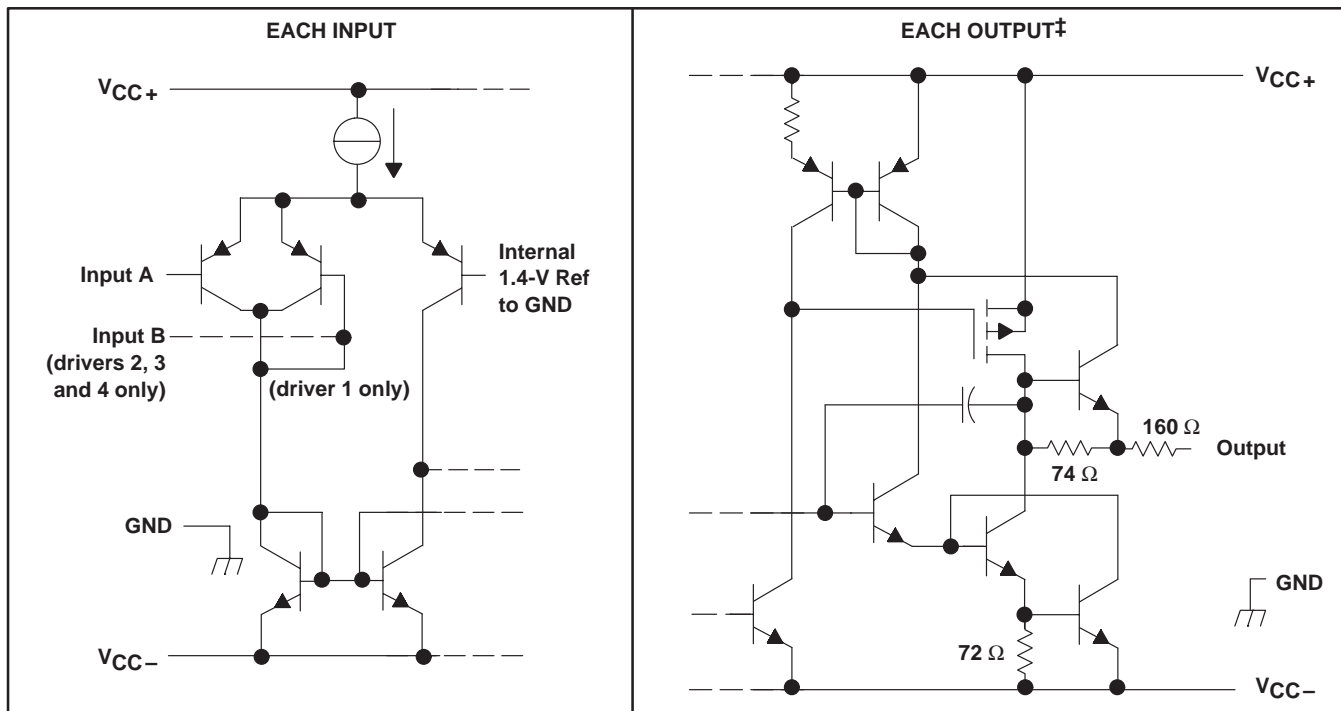

‡ All resistor values shown are nominal.

SN75C188 QUADRUPLE LOW-POWER LINE DRIVERS

SLLS033F – JANUARY 1988 – REVISED MARCH 1997

absolute maximum ratings over operating free-air temperature range (unless otherwise noted)†

Supply voltage, V_{CC+} (see Note 1)	15 V
Supply voltage, V_{CC-} (see Note 1)	-15 V
Input voltage range, V_I	V_{CC-} to V_{CC+}
Output voltage range, V_O	$V_{CC-} - 6\text{ V}$ to $V_{CC+} + 6\text{ V}$
Continuous total power dissipation	See Dissipation Rating Table
Operating free-air temperature range, T_A	0°C to 70°C
Storage temperature range, T_{stg}	-65°C to 150°C
Lead temperature 1,6 mm (1/16 inch) from case for 10 seconds	260°C

† Stresses beyond those listed under “absolute maximum ratings” may cause permanent damage to the device. These are stress ratings only, and functional operation of the device at these or any other conditions beyond those indicated under “recommended operating conditions” is not implied. Exposure to absolute-maximum-rated conditions for extended periods may affect device reliability.

NOTE 1: All voltage values are with respect to the network ground terminal.

DISSIPATION RATING TABLE

PACKAGE	$T_A \leq 25^\circ\text{C}$ POWER RATING	DERATING FACTOR ABOVE $T_A = 25^\circ\text{C}$	$T_A = 70^\circ\text{C}$ POWER RATING
D	950 mW	7.6 mW/°C	608 mW
DB	525 mW	4.2 mW/°C	336 mW
N	1150 mW	9.2 mW/°C	736 mW

recommended operating conditions

	MIN	NOM	MAX	UNIT
Supply voltage, V_{CC+}	4.5	12	15	V
Supply voltage, V_{CC-}	-4.5	-12	-15	V
Input voltage, V_I	$V_{CC-} + 2$		V_{CC+}	V
High-level Input voltage, V_{IH}	2			V
Low-level Input voltage, V_{IL}			0.8	V
Operating free-air temperature, T_A	0		70	°C

SN75C188

QUADRUPLE LOW-POWER LINE DRIVERS

SLLS033F – JANUARY 1988 – REVISED MARCH 1997

electrical characteristics over operating free-air temperature range, $V_{CC+} = 12\text{ V}$, $V_{CC-} = -12\text{ V}$ (unless otherwise noted)

PARAMETER		TEST CONDITIONS		MIN	TYP†	MAX	UNIT	
V_{OH}	High-level output voltage	$V_{IL} = 0.8\text{ V}$, $R_L = 3\text{ k}\Omega$	$V_{CC+} = 5\text{ V}$, $V_{CC-} = -5\text{ V}$	4			V	
			$V_{CC+} = 12\text{ V}$, $V_{CC-} = -12\text{ V}$	10				
V_{OL}	Low-level output voltage (see Note 2)	$V_{IH} = 2\text{ V}$, $R_L = 3\text{ k}\Omega$	$V_{CC+} = 5\text{ V}$, $V_{CC-} = -5\text{ V}$	-4			V	
			$V_{CC+} = 12\text{ V}$, $V_{CC-} = -12\text{ V}$	-10				
I_{IH}	High-level input current	$V_I = 5\text{ V}$		10			μA	
I_{IL}	Low-level input current	$V_I = 0$		-10			μA	
$I_{OS(H)}$	High-level short-circuit output current‡	$V_I = 0.8\text{ V}$, $V_O = 0$ or V_{CC-}			-5.5	-10	-19.5	mA
$I_{OS(L)}$	Low-level short-circuit output current‡	$V_I = 2\text{ V}$, $V_O = 0$ or V_{CC+}			5.5	10	19.5	mA
r_O	Output resistance, power off	$V_{CC+} = 0$, $V_{CC-} = 0$, $V_I = -2\text{ V}$ to 2 V			300			Ω
I_{CC+}	Supply current from V_{CC+}	$V_{CC+} = 5\text{ V}$, $V_{CC-} = -5\text{ V}$, No load	All inputs at 2 V or 0.8 V		90	160		μA
		$V_{CC+} = 12\text{ V}$, $V_{CC-} = -12\text{ V}$, No load	All inputs at 2 V or 0.8 V		95	160		
I_{CC-}	Supply current from V_{CC-}	$V_{CC+} = 5\text{ V}$, $V_{CC-} = -5\text{ V}$, No load	All inputs at 2 V or 0.8 V		-90	-160		μA
		$V_{CC+} = 12\text{ V}$, $V_{CC-} = -12\text{ V}$, No load	All inputs at 2 V or 0.8 V		-95	-160		

† All typical values are at $T_A = 25^\circ\text{C}$.

‡ Not more than one output should be shorted at a time.

NOTE 2: The algebraic convention, in which the more positive (less negative) limit is designated as maximum, is used in this data sheet for logic levels only; e.g., if -4 V is a maximum, the typical value is a more negative voltage.

switching characteristics, $V_{CC+} = 12\text{ V}$, $V_{CC-} = -12\text{ V}$, $T_A = 25^\circ\text{C}$

PARAMETER		TEST CONDITIONS		MIN	TYP	MAX	UNIT	
t_{PLH}	Propagation delay time, low- to high-level output§	$R_L = 3\text{ k}\Omega$, See Figure 1	$C_L = 15\text{ pF}$	3			μs	
t_{PHL}	Propagation delay time, high- to low-level output§			3.5			μs	
t_{TLH}	Transition time, low- to high-level output¶			0.53	3.2		μs	
t_{THL}	Transition time, high- to low-level output¶			0.53	3.2		μs	
t_{TLH}	Transition time, low- to high-level output#	$R_L = 3\text{ k}\Omega$ to $7\text{ k}\Omega$, See Figure 1	$C_L = 2500\text{ pF}$	1.5			μs	
t_{THL}	Transition time, high- to low-level output#			1.5			μs	
SR	Output slew rate§	$R_L = 3\text{ k}\Omega$ to $7\text{ k}\Omega$, $C_L = 15\text{ pF}$			6	15	30	$\text{V}/\mu\text{s}$

§ Measured at the 50% level

¶ Measured between the 10% and 90% points on the output waveform

Measured between the 3-V and -3 V points on the output waveform (EIA/TIA-232-E conditions), all unused inputs tied either high or low

PARAMETER MEASUREMENT INFORMATION

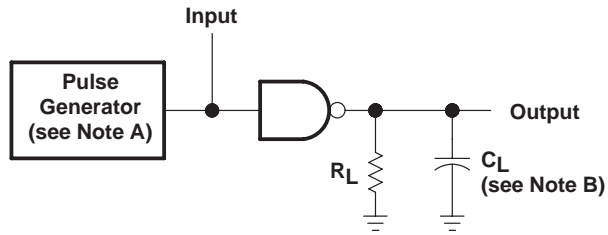

TEST CIRCUIT

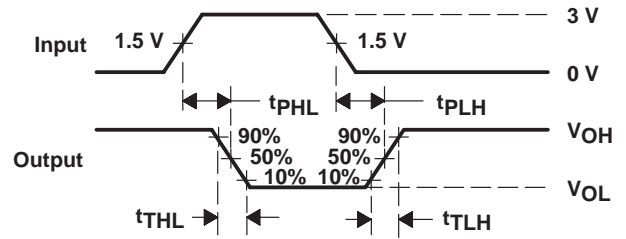

VOLTAGE WAVEFORMS

NOTES: A. The pulse generator has the following characteristics: $t_w = 25 \mu s$, $PRR = 20 \text{ kHz}$, $Z_O = 50 \Omega$, $t_r = t_f \leq 50 \text{ ns}$.
 B. C_L includes probe and jig capacitance.

Figure 1. Test Circuit and Voltage Waveforms

SN75C188 QUADRUPLE LOW-POWER LINE DRIVERS

SLLS033F – JANUARY 1988 – REVISED MARCH 1997

TYPICAL CHARACTERISTICS

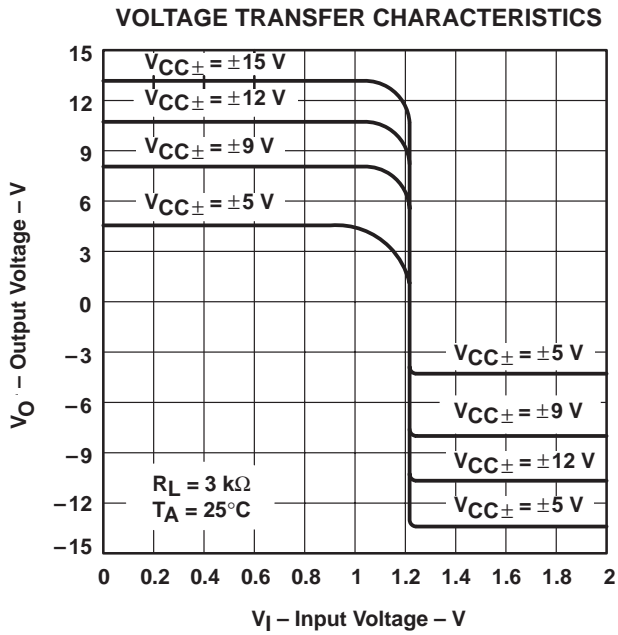

Figure 2

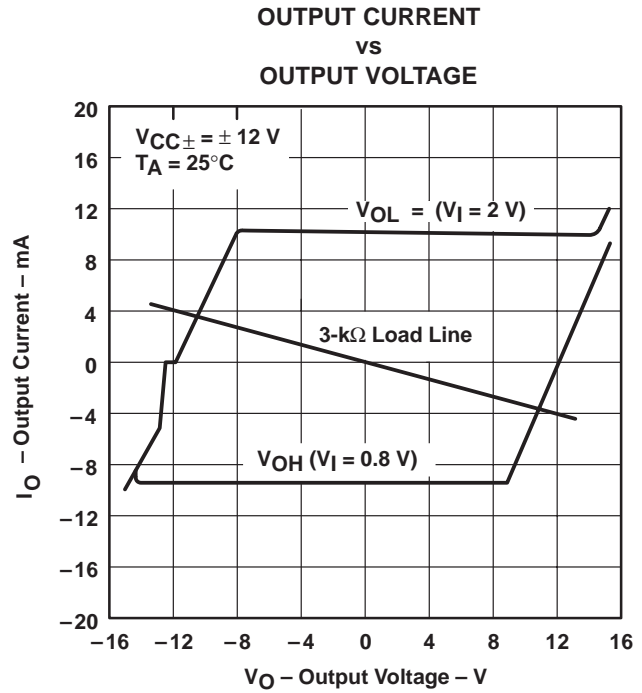

Figure 3

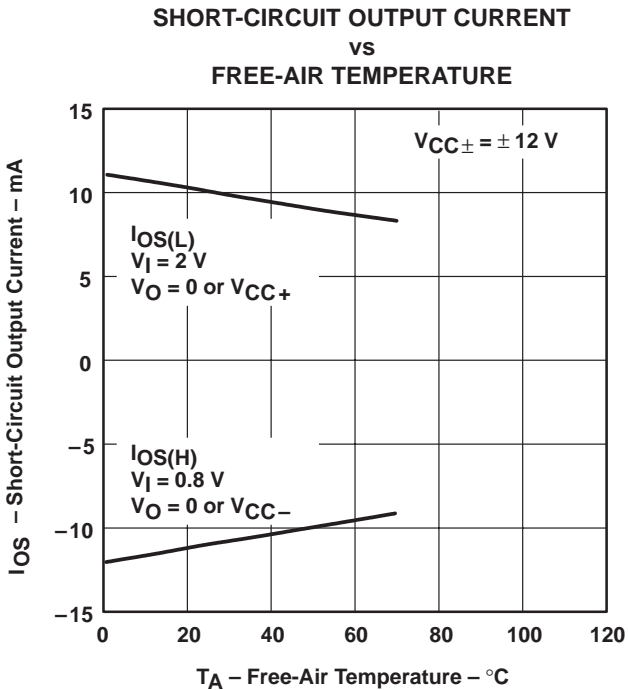

Figure 4

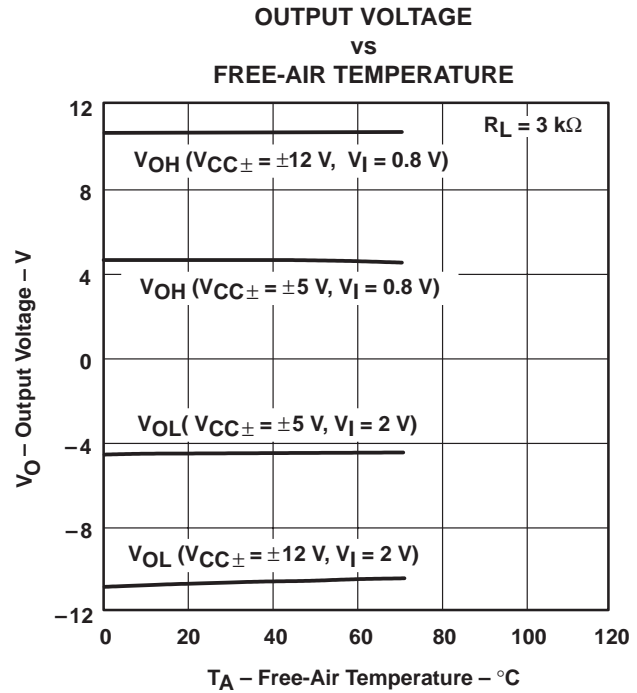
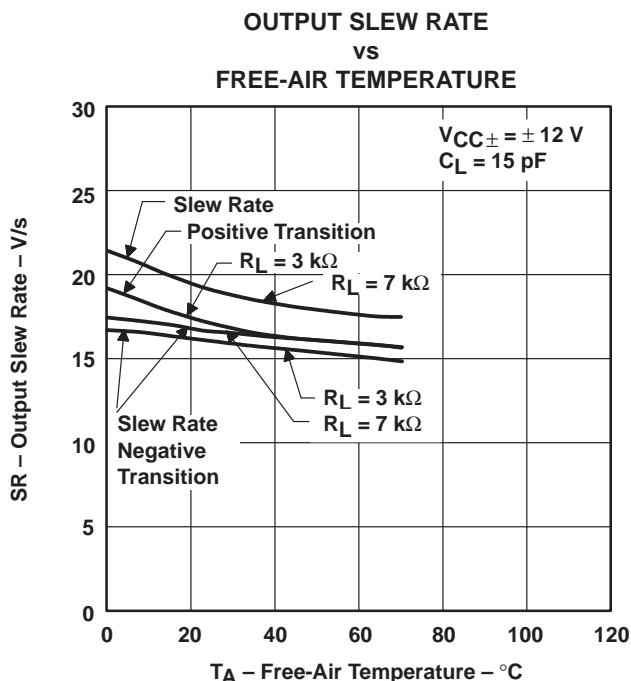
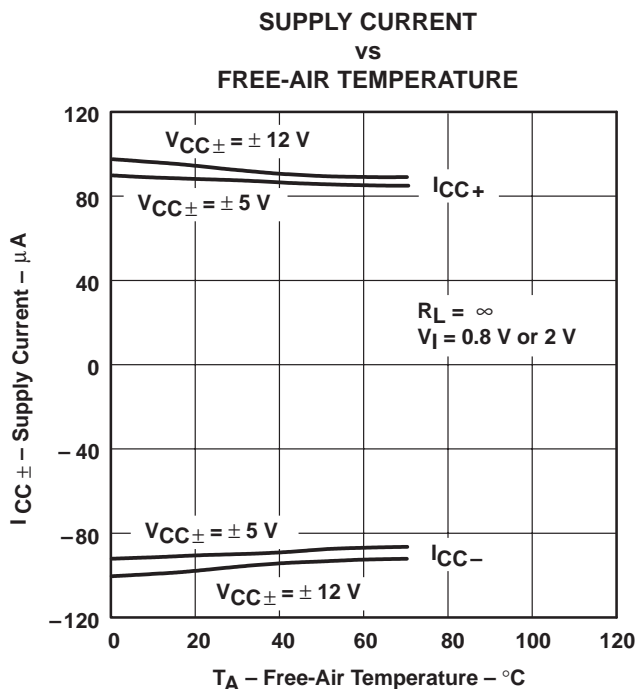
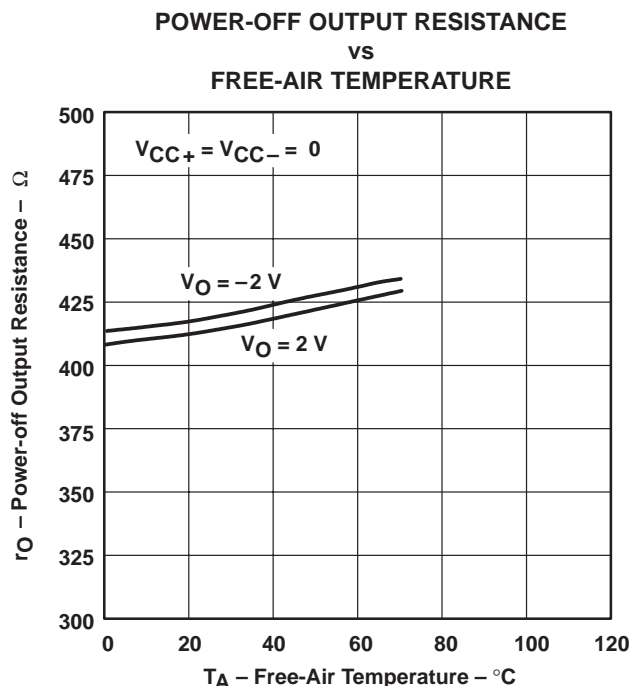
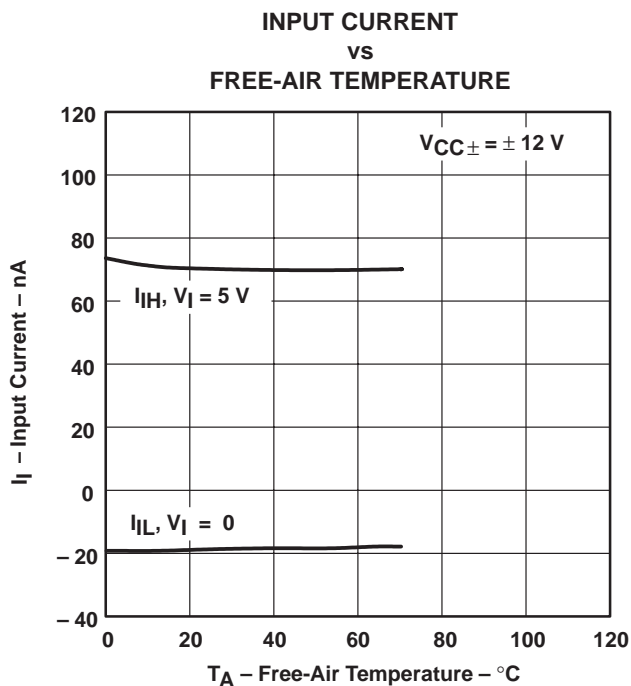

Figure 5

TYPICAL CHARACTERISTICS



SN75C188 QUADRUPLE LOW-POWER LINE DRIVERS

SLLS033F – JANUARY 1988 – REVISED MARCH 1997

TYPICAL CHARACTERISTICS

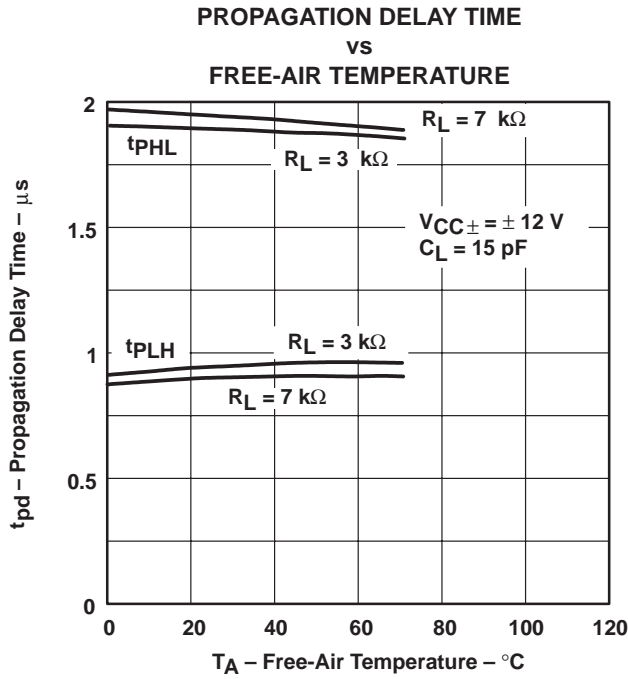

Figure 10

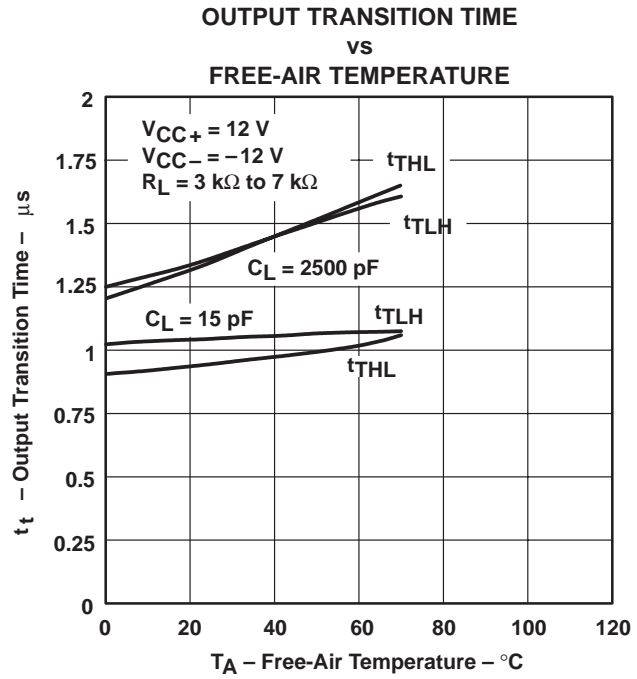

Figure 11

APPLICATION INFORMATION

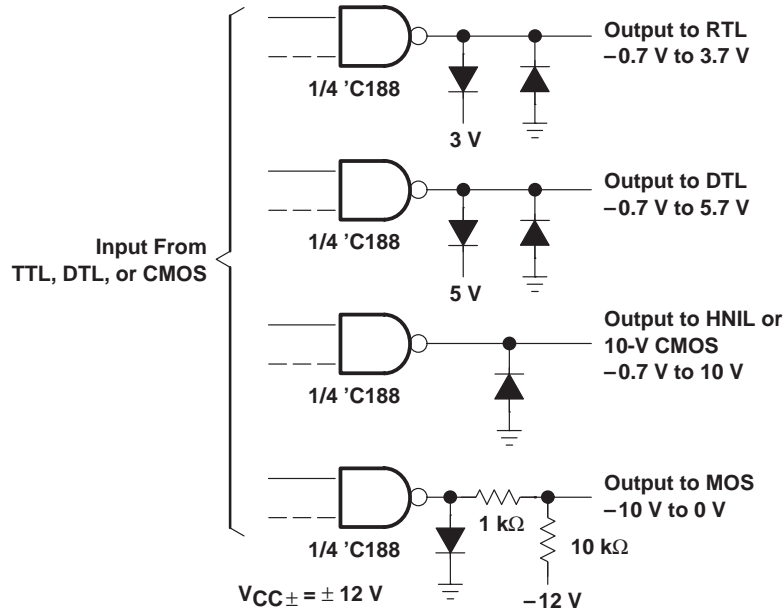
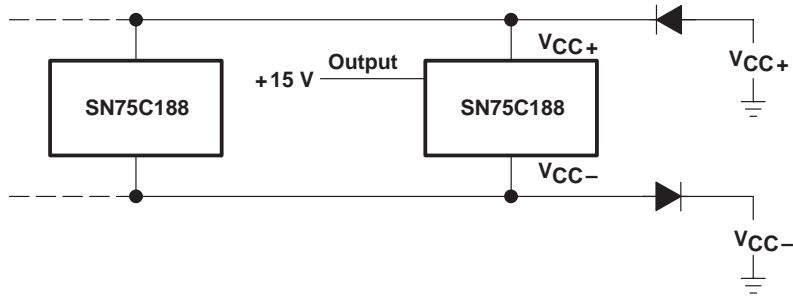

Figure 12. Logic Translator Applications

APPLICATION INFORMATION



NOTE A: External diodes placed in series with the V_{CC+} and V_{CC-} leads protect the SN75C188 in the fault condition where the device outputs are shorted to ± 15 V and the power supplies are at low voltage and provide low-impedance paths to GND.

Figure 13. Power Supply Protection to Meet Power-Off Fault Conditions of Standard EIA/TIA-232-E

PACKAGING INFORMATION

Orderable Device	Status (1)	Package Type	Package Drawing	Pins	Package Qty	Eco Plan (2)	Lead/Ball Finish (6)	MSL Peak Temp (3)	Op Temp (°C)	Device Marking (4/5)	Samples
SN75C188D	ACTIVE	SOIC	D	14	50	Green (RoHS & no Sb/Br)	CU NIPDAU	Level-1-260C-UNLIM	0 to 70	SN75C188	Samples
SN75C188DBLE	OBSOLETE	SSOP	DB	14		TBD	Call TI	Call TI	0 to 70		
SN75C188DBR	ACTIVE	SSOP	DB	14	2000	Green (RoHS & no Sb/Br)	CU NIPDAU	Level-1-260C-UNLIM	0 to 70	CA188	Samples
SN75C188DE4	ACTIVE	SOIC	D	14	50	Green (RoHS & no Sb/Br)	CU NIPDAU	Level-1-260C-UNLIM	0 to 70	SN75C188	Samples
SN75C188DR	ACTIVE	SOIC	D	14	2500	Green (RoHS & no Sb/Br)	CU NIPDAU	Level-1-260C-UNLIM	0 to 70	SN75C188	Samples
SN75C188DRE4	ACTIVE	SOIC	D	14	2500	Green (RoHS & no Sb/Br)	CU NIPDAU	Level-1-260C-UNLIM	0 to 70	SN75C188	Samples
SN75C188N	ACTIVE	PDIP	N	14	25	Pb-Free (RoHS)	CU NIPDAU	N / A for Pkg Type	0 to 70	SN75C188N	Samples
SN75C188NE4	ACTIVE	PDIP	N	14	25	Pb-Free (RoHS)	CU NIPDAU	N / A for Pkg Type	0 to 70	SN75C188N	Samples
SN75C188NSR	ACTIVE	SO	NS	14	2000	Green (RoHS & no Sb/Br)	CU NIPDAU	Level-1-260C-UNLIM	0 to 70	75C188	Samples

(1) The marketing status values are defined as follows:

ACTIVE: Product device recommended for new designs.

LIFEBUY: TI has announced that the device will be discontinued, and a lifetime-buy period is in effect.

NRND: Not recommended for new designs. Device is in production to support existing customers, but TI does not recommend using this part in a new design.

PREVIEW: Device has been announced but is not in production. Samples may or may not be available.

OBSOLETE: TI has discontinued the production of the device.

(2) Eco Plan - The planned eco-friendly classification: Pb-Free (RoHS), Pb-Free (RoHS Exempt), or Green (RoHS & no Sb/Br) - please check <http://www.ti.com/productcontent> for the latest availability information and additional product content details.

TBD: The Pb-Free/Green conversion plan has not been defined.

Pb-Free (RoHS): TI's terms "Lead-Free" or "Pb-Free" mean semiconductor products that are compatible with the current RoHS requirements for all 6 substances, including the requirement that lead not exceed 0.1% by weight in homogeneous materials. Where designed to be soldered at high temperatures, TI Pb-Free products are suitable for use in specified lead-free processes.

Pb-Free (RoHS Exempt): This component has a RoHS exemption for either 1) lead-based flip-chip solder bumps used between the die and package, or 2) lead-based die adhesive used between the die and leadframe. The component is otherwise considered Pb-Free (RoHS compatible) as defined above.

Green (RoHS & no Sb/Br): TI defines "Green" to mean Pb-Free (RoHS compatible), and free of Bromine (Br) and Antimony (Sb) based flame retardants (Br or Sb do not exceed 0.1% by weight in homogeneous material)

(3) MSL, Peak Temp. - The Moisture Sensitivity Level rating according to the JEDEC industry standard classifications, and peak solder temperature.

(4) There may be additional marking, which relates to the logo, the lot trace code information, or the environmental category on the device.

(5) Multiple Device Markings will be inside parentheses. Only one Device Marking contained in parentheses and separated by a "~" will appear on a device. If a line is indented then it is a continuation of the previous line and the two combined represent the entire Device Marking for that device.

(6) Lead/Ball Finish - Orderable Devices may have multiple material finish options. Finish options are separated by a vertical ruled line. Lead/Ball Finish values may wrap to two lines if the finish value exceeds the maximum column width.

Important Information and Disclaimer: The information provided on this page represents TI's knowledge and belief as of the date that it is provided. TI bases its knowledge and belief on information provided by third parties, and makes no representation or warranty as to the accuracy of such information. Efforts are underway to better integrate information from third parties. TI has taken and continues to take reasonable steps to provide representative and accurate information but may not have conducted destructive testing or chemical analysis on incoming materials and chemicals. TI and TI suppliers consider certain information to be proprietary, and thus CAS numbers and other limited information may not be available for release.

In no event shall TI's liability arising out of such information exceed the total purchase price of the TI part(s) at issue in this document sold by TI to Customer on an annual basis.

TAPE AND REEL INFORMATION

REEL DIMENSIONS

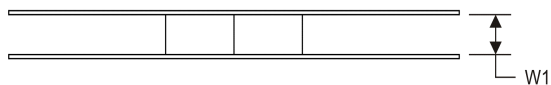
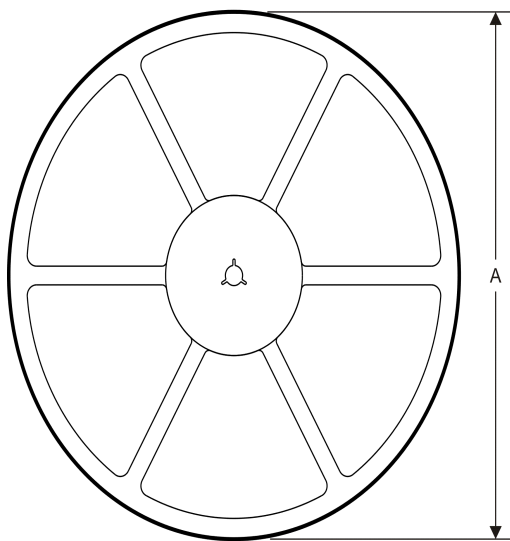

TAPE DIMENSIONS

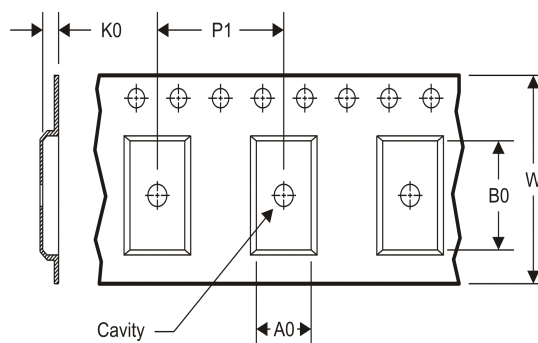

A0	Dimension designed to accommodate the component width
B0	Dimension designed to accommodate the component length
K0	Dimension designed to accommodate the component thickness
W	Overall width of the carrier tape
P1	Pitch between successive cavity centers

TAPE AND REEL INFORMATION

*All dimensions are nominal

Device	Package Type	Package Drawing	Pins	SPQ	Reel Diameter (mm)	Reel Width W1 (mm)	A0 (mm)	B0 (mm)	K0 (mm)	P1 (mm)	W (mm)	Pin1 Quadrant
SN75C188DBR	SSOP	DB	14	2000	330.0	16.4	8.2	6.6	2.5	12.0	16.0	Q1
SN75C188DR	SOIC	D	14	2500	330.0	16.4	6.5	9.0	2.1	8.0	16.0	Q1
SN75C188DR	SOIC	D	14	2500	330.0	16.4	6.5	9.0	2.1	8.0	16.0	Q1
SN75C188NSR	SO	NS	14	2000	330.0	16.4	8.2	10.5	2.5	12.0	16.0	Q1

TAPE AND REEL BOX DIMENSIONS

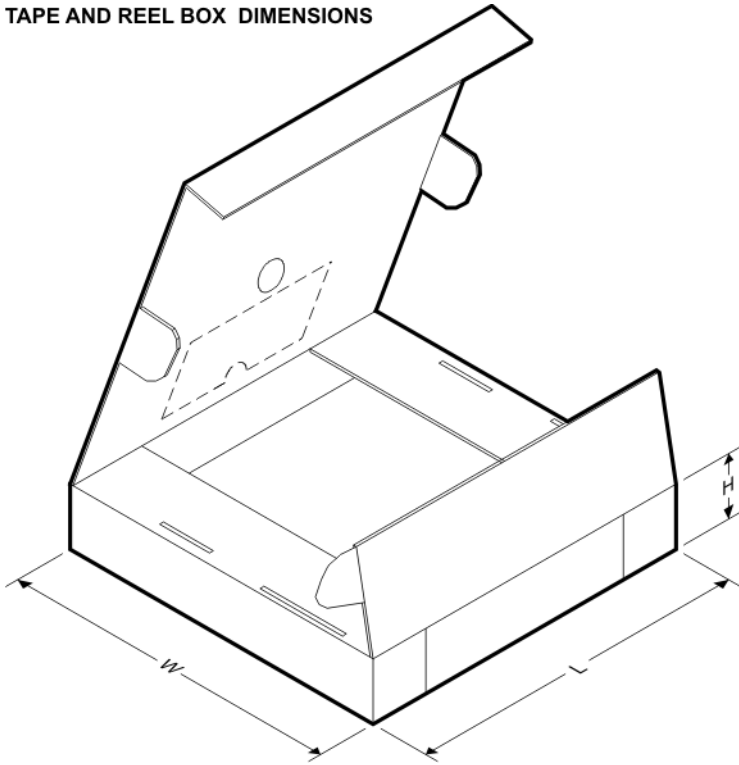

*All dimensions are nominal

Device	Package Type	Package Drawing	Pins	SPQ	Length (mm)	Width (mm)	Height (mm)
SN75C188DBR	SSOP	DB	14	2000	367.0	367.0	38.0
SN75C188DR	SOIC	D	14	2500	333.2	345.9	28.6
SN75C188DR	SOIC	D	14	2500	367.0	367.0	38.0
SN75C188NSR	SO	NS	14	2000	367.0	367.0	38.0

N (R-PDIP-T**)

PLASTIC DUAL-IN-LINE PACKAGE

16 PINS SHOWN

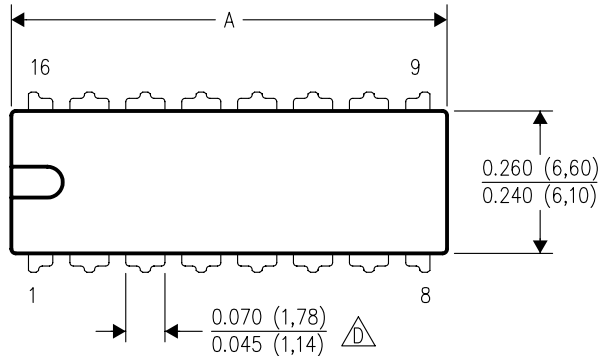

DIM \ PINS **	14	16	18	20
	A MAX	0.775 (19,69)	0.775 (19,69)	0.920 (23,37)
A MIN	0.745 (18,92)	0.745 (18,92)	0.850 (21,59)	0.940 (23,88)
MS-001 VARIATION	AA	BB	AC	AD

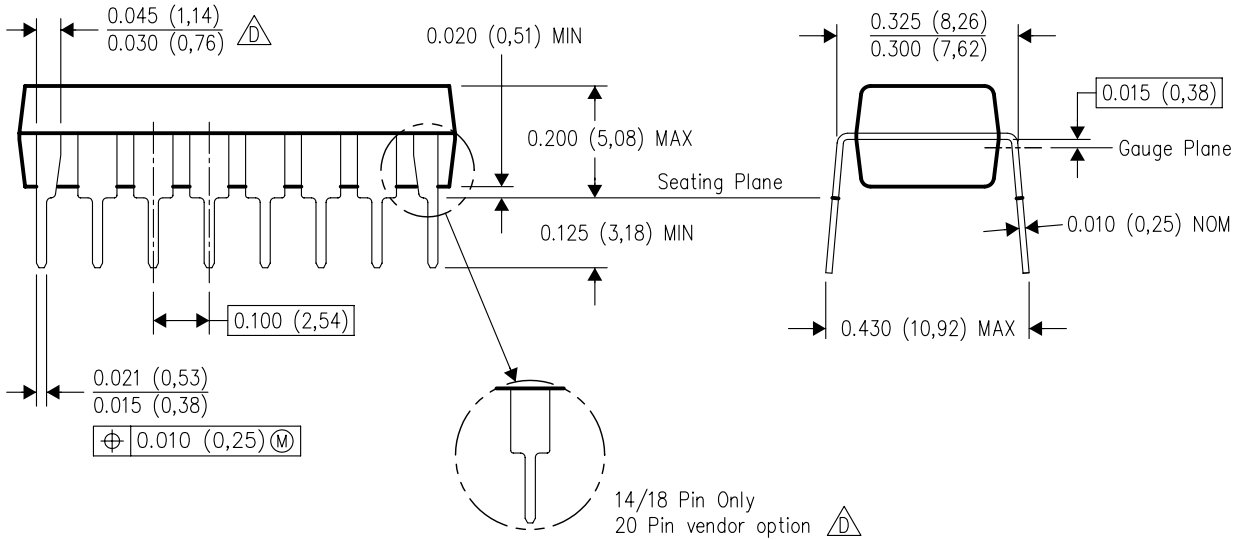

4040049/E 12/2002

- NOTES:
- A. All linear dimensions are in inches (millimeters).
 - B. This drawing is subject to change without notice.
 - Falls within JEDEC MS-001, except 18 and 20 pin minimum body length (Dim A).
 - The 20 pin end lead shoulder width is a vendor option, either half or full width.

D (R-PDSO-G14)

PLASTIC SMALL OUTLINE

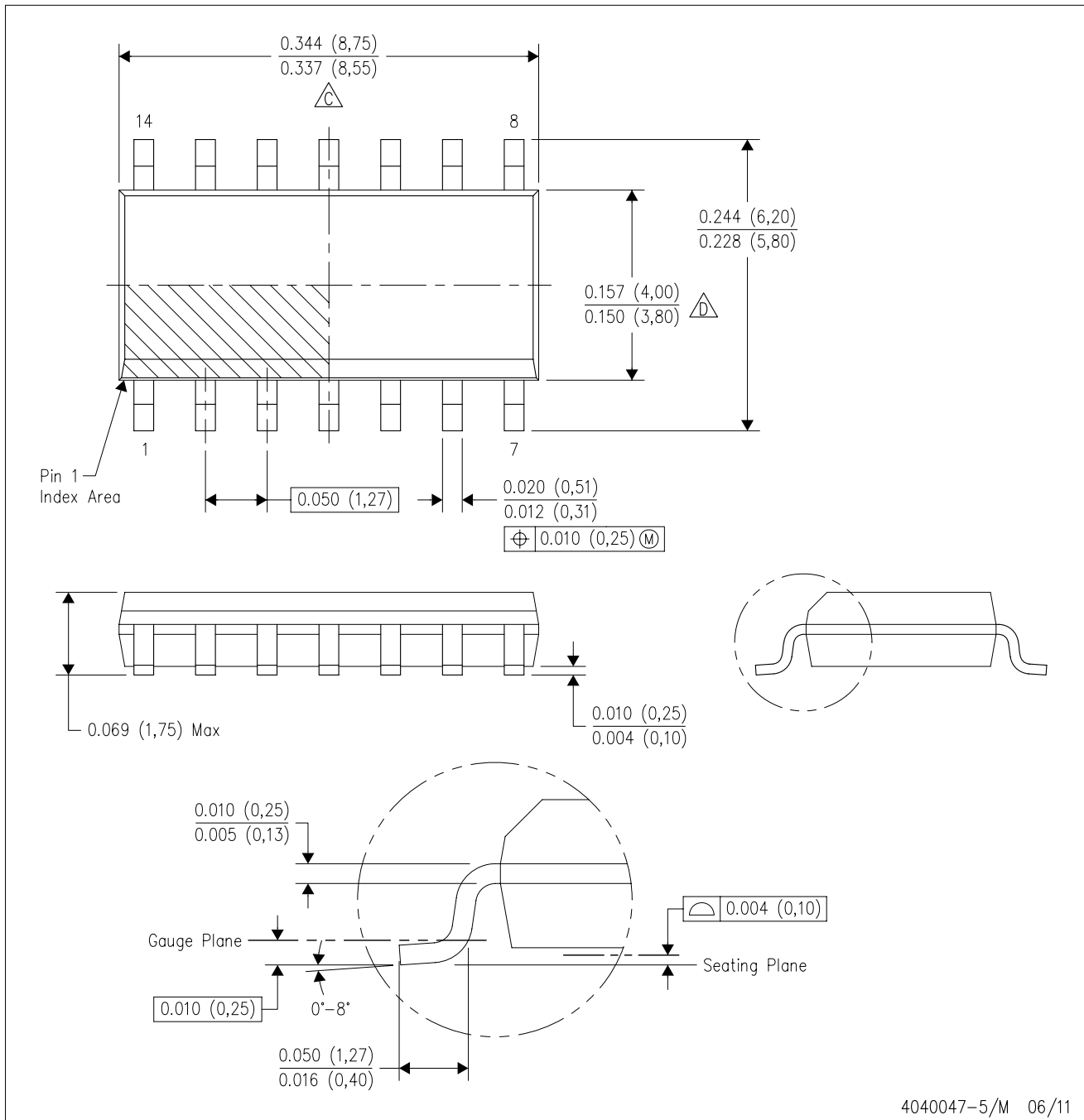

- NOTES:
- A. All linear dimensions are in inches (millimeters).
 - B. This drawing is subject to change without notice.
 - Body length does not include mold flash, protrusions, or gate burrs. Mold flash, protrusions, or gate burrs shall not exceed 0.006 (0,15) each side.
 - Body width does not include interlead flash. Interlead flash shall not exceed 0.017 (0,43) each side.
 - E. Reference JEDEC MS-012 variation AB.

D (R-PDSO-G14)

PLASTIC SMALL OUTLINE

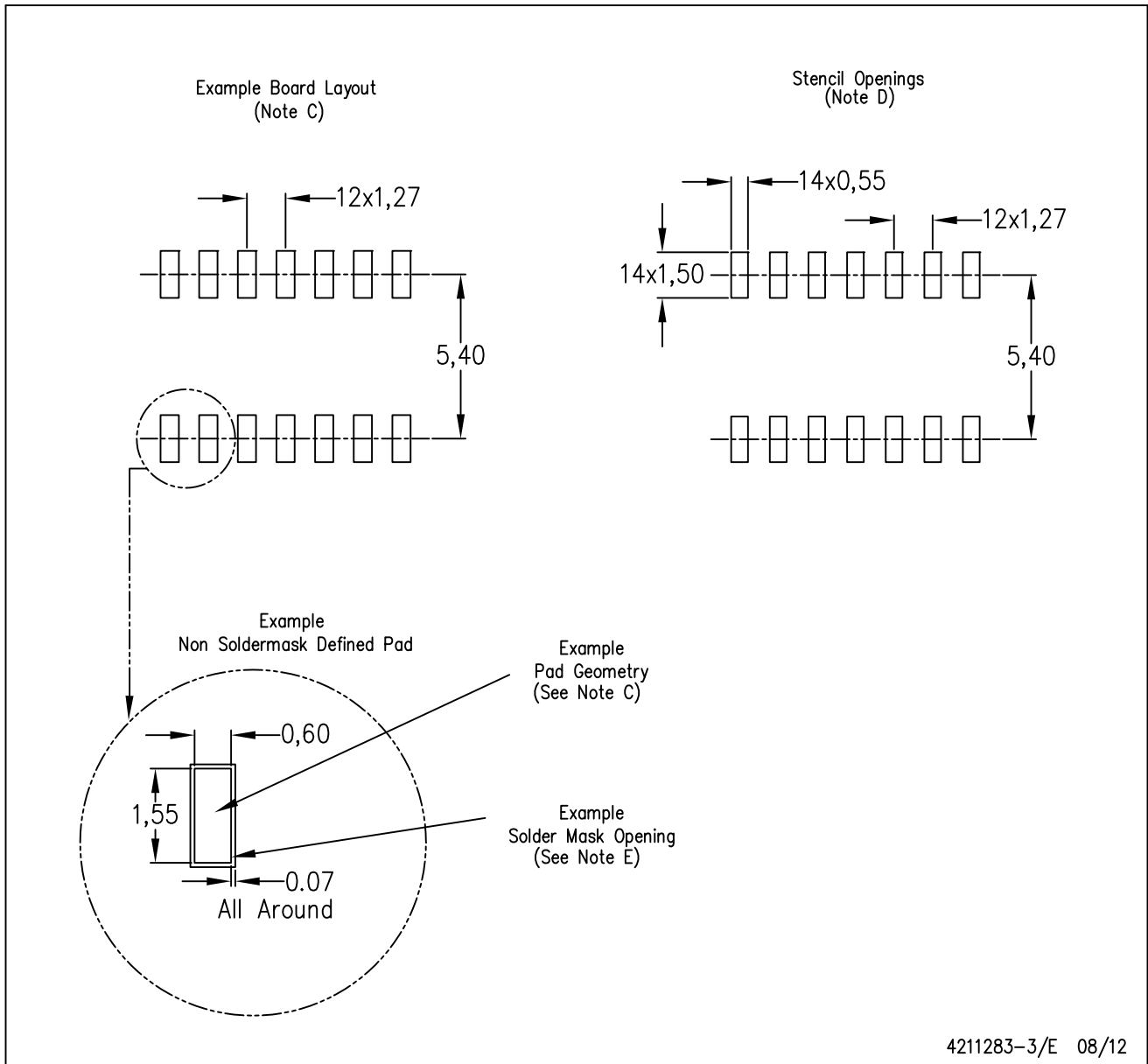

- NOTES:
- All linear dimensions are in millimeters.
 - This drawing is subject to change without notice.
 - Publication IPC-7351 is recommended for alternate designs.
 - Laser cutting apertures with trapezoidal walls and also rounding corners will offer better paste release. Customers should contact their board assembly site for stencil design recommendations. Refer to IPC-7525 for other stencil recommendations.
 - Customers should contact their board fabrication site for solder mask tolerances between and around signal pads.

MECHANICAL DATA

NS (R-PDSO-G**)

PLASTIC SMALL-OUTLINE PACKAGE

14-PINS SHOWN



- NOTES:
- A. All linear dimensions are in millimeters.
 - B. This drawing is subject to change without notice.
 - C. Body dimensions do not include mold flash or protrusion, not to exceed 0,15.

DB (R-PDSO-G**)

PLASTIC SMALL-OUTLINE

28 PINS SHOWN

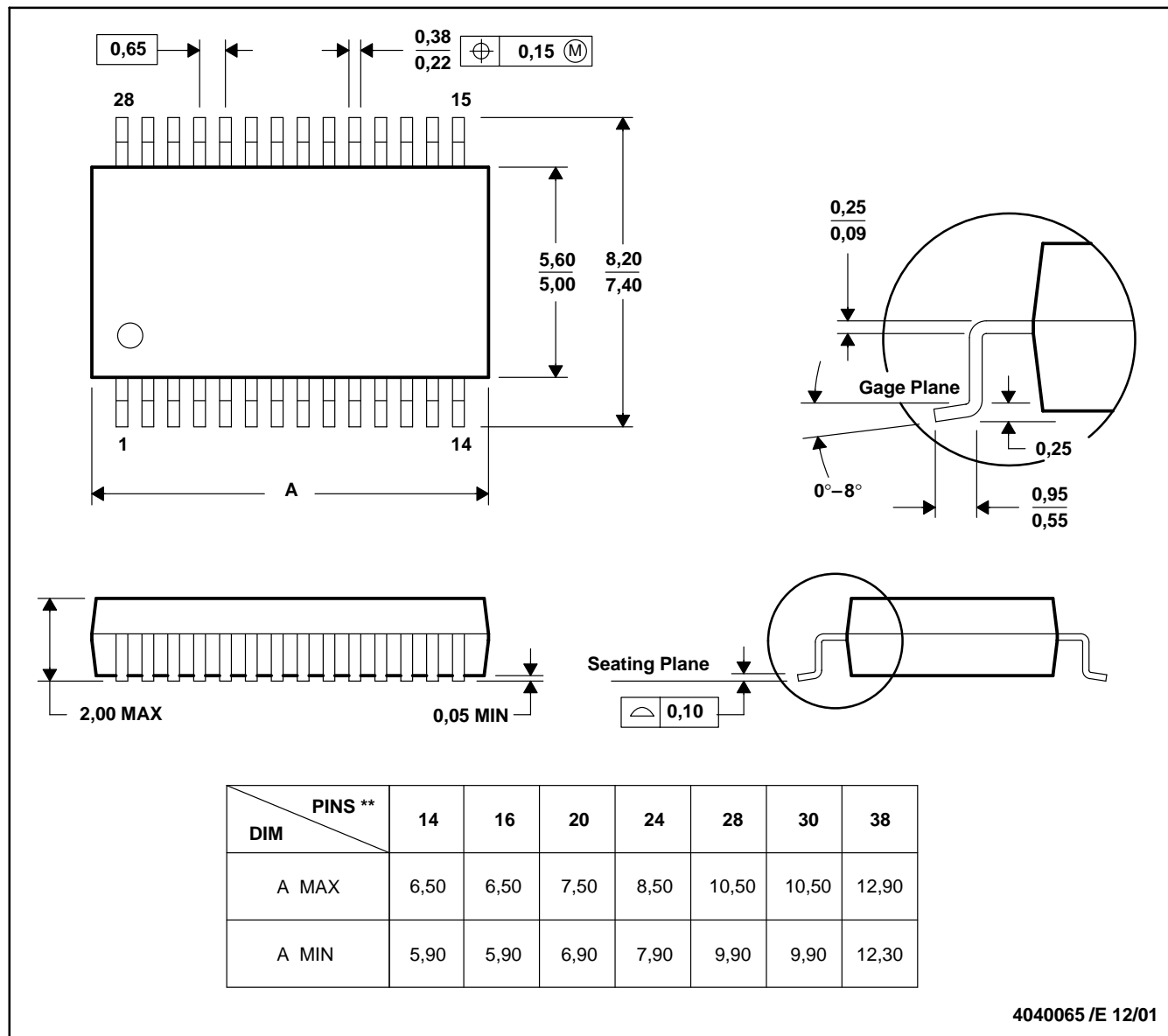

- NOTES: A. All linear dimensions are in millimeters.
 B. This drawing is subject to change without notice.
 C. Body dimensions do not include mold flash or protrusion not to exceed 0,15.
 D. Falls within JEDEC MO-150