

# SN65LBC170, SN75LBC170 TRIPLE DIFFERENTIAL TRANSCEIVERS

SLLS459C – NOVEMBER 2000 – REVISED MARCH 2005

- Three Differential Transceivers in One Package
- Signaling Rates† Up to 30 Mbps
- Low Power and High Speed
- Designed for TIA/EIA-485, TIA/EIA-422, ISO 8482, and ANSI X3.277 (HVD SCSI Fast-20) Applications
- Common-Mode Bus Voltage Range –7 V to 12 V
- ESD Protection on Bus Terminals Exceeds 12 kV
- Driver Output Current up to  $\pm 60$  mA
- Thermal Shutdown Protection
- Driver Positive and Negative Current Limiting
- Power-Up, Power-Down Glitch-Free Operation
- Pin-Compatible With the SN75ALS170
- Available in Shrink Small-Outline Package

## description

The SN65LBC170 and SN75LBC170 are monolithic integrated circuits designed for bidirectional data communication on multipoint bus-transmission lines. Potential applications include serial or parallel data transmission, cabled peripheral buses with twin axial, ribbon, or twisted-pair cabling. These devices are suitable for FAST-20 SCSI and can transmit or receive data pulses as short as 25 ns, with skew less than 3 ns.

These devices combine three 3-state differential line drivers and three differential input line receivers, all of which operate from a single 5-V power supply.

The driver differential outputs and the receiver differential inputs are connected internally to form three differential input/output (I/O) bus ports that are designed to offer minimum loading to the bus whenever the driver is disabled or  $V_{CC} = 0$ . These ports feature a wide common-mode voltage range making the device suitable for party-line applications over long cable runs.

SN65LBC170DB (marked as BL170)  
SN75LBC170DB (marked as BL170)

(TOP VIEW)

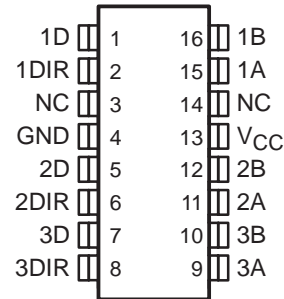

SN65LBC170DW (marked as 65LBC170)  
SN75LBC170DW (marked as 75LBC170)

(TOP VIEW)

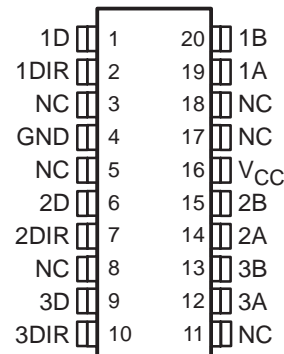

NC – No internal connection

## logic diagram

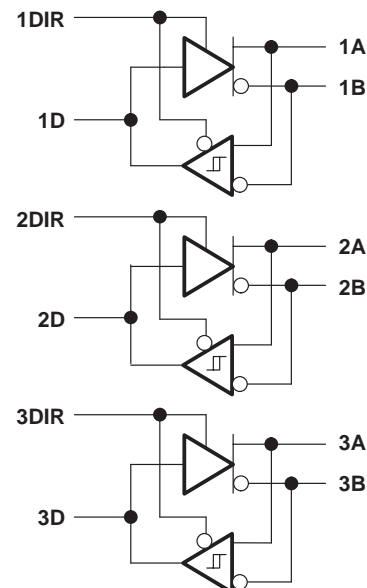

Please be aware that an important notice concerning availability, standard warranty, and use in critical applications of Texas Instruments semiconductor products and disclaimers thereto appears at the end of this data sheet.

†The signaling rate of a line is the number of voltage transitions that are made per second expressed in the units bps (bits per second).

PRODUCTION DATA information is current as of publication date. Products conform to specifications per the terms of Texas Instruments standard warranty. Production processing does not necessarily include testing of all parameters.

**TEXAS  
INSTRUMENTS**

POST OFFICE BOX 655303 • DALLAS, TEXAS 75265

Copyright © 2002, Texas Instruments Incorporated

# SN65LBC170, SN75LBC170 TRIPLE DIFFERENTIAL TRANSCEIVERS

SLLS459C – NOVEMBER 2000 – REVISED MARCH 2005

## description (continued)

The driver's active-high enable and the receiver's active-low enable are tied together internally and provide a direction input for each driver/receiver pair.

The SN75LBC170 is characterized for operation over the temperature range of 0°C to 70°C. The SN65LBC170 is characterized for operation over the temperature range of -40°C to 85°C.

### AVAILABLE OPTIONS†

T <sub>A</sub>	PACKAGE	
	PLASTIC SHRINK SMALL-OUTLINE (JEDEC MO-150)	PLASTIC SMALL-OUTLINE (JEDEC MS-013)
0°C to 70°C	SN75LBC170DB	SN75LBC170DW
-40°C to 85°C	SN65LBC170DB	SN65LBC170DW

† Add R suffix for taped and reel

† For the most current package and ordering information, see the Package Option Addendum at the end of this document, or see the TI web site at [www.ti.com](http://www.ti.com).

### Function Tables

EACH DRIVER			EACH RECEIVER			
INPUT D	ENABLE DIR	OUTPUTS		DIFFERENTIAL INPUT (V <sub>A</sub> -V <sub>B</sub> )	ENABLE DIR	OUTPUT D
		A	B			
H	H	H	L	V <sub>ID</sub> ≥ 0.2 V	L	H
L	H	L	H	-0.2 V < V <sub>ID</sub> < 0.2 V	L	?
OPEN	H	L	H	V <sub>ID</sub> ≤ -0.2 V	L	L
X	L	Z	Z	X	H	Z
X	OPEN	X	X	OPEN	L	H

H = high level, L = low level, X = irrelevant, Z = high impedance (off), ? = indeterminate

## equivalent input and output schematic diagrams

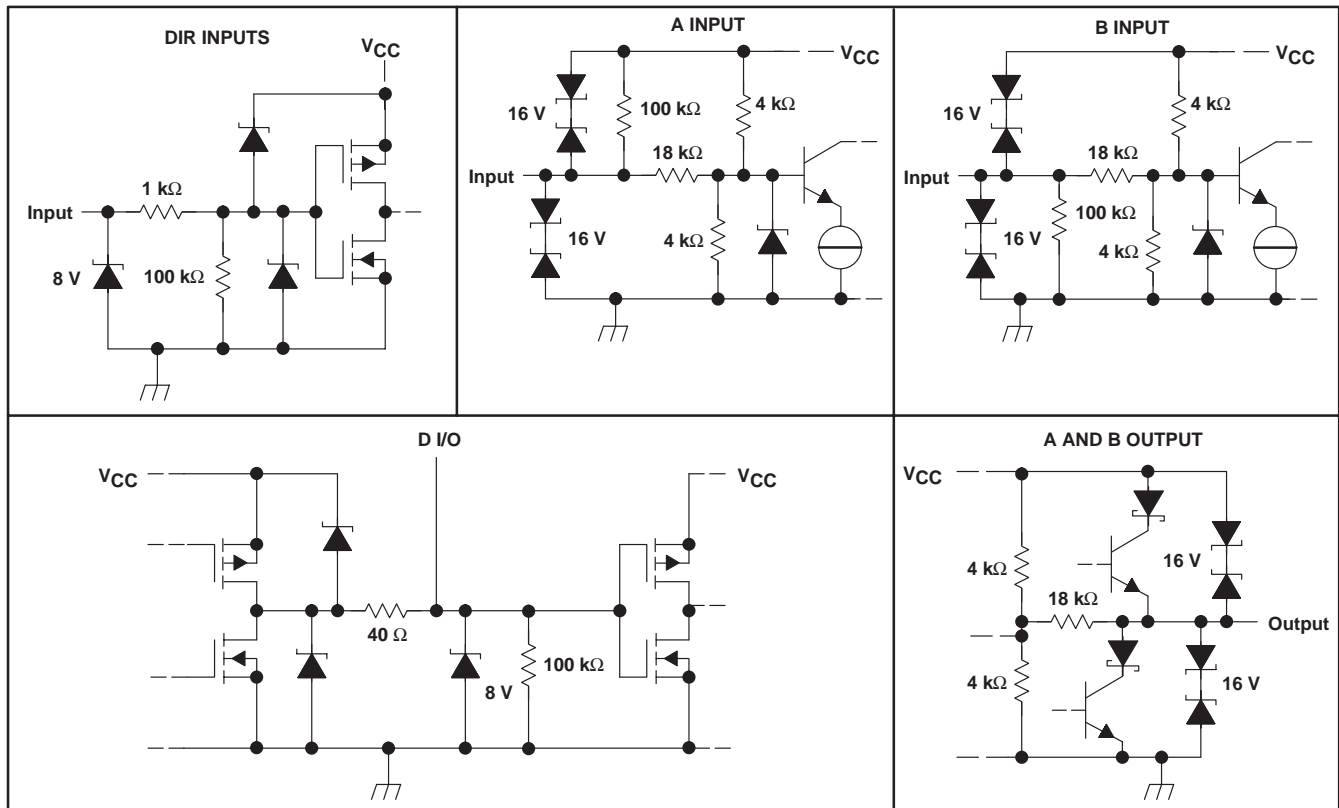

# SN65LBC170, SN75LBC170 TRIPLE DIFFERENTIAL TRANSCEIVERS

SLLS459C – NOVEMBER 2000 – REVISED MARCH 2005

## absolute maximum ratings<sup>†</sup> over operating free-air temperature range (unless otherwise noted)

Supply voltage, $V_{CC}$ (see Note 1)	–0.3 V to 6 V
Voltage range at any bus I/O terminal (steady state)	–10 V to 15 V
Voltage input range, A and B, (transient pulse through 100 $\Omega$ , see Figure 12)	–30 V to 30 V
Voltage range at any D or DIR terminal	–0.5 V to $V_{CC} + 0.5$ V
Receiver output current, $I_O$	$\pm 10$ mA
Electrostatic discharge: Human body model (A, B, GND) (see Note 2)	12 kV
All pins	5 kV
Charged-device model (all pins) (see Note 3)	1 kV
Continuous total power dissipation	See Power Dissipation Rating Table

<sup>†</sup> Stresses beyond those listed under “absolute maximum ratings” may cause permanent damage to the device. These are stress ratings only, and functional operation of the device at these or any other conditions beyond those indicated under “recommended operating conditions” is not implied. Exposure to absolute-maximum-rated conditions for extended periods may affect device reliability.

- NOTES: 1. All voltage values, except differential I/O bus voltages, are with respect to network ground terminal.  
 2. Tested in accordance with JEDEC Standard 22, Test Method A114–A.  
 3. Tested in accordance with JEDEC Standard 22, Test Method C101.

POWER DISSIPATION RATING TABLE

PACKAGE	$T_A \leq 25^\circ\text{C}$ POWER RATING	DERATING FACTOR <sup>‡</sup> ABOVE $T_A = 25^\circ\text{C}$	$T_A = 70^\circ\text{C}$ POWER RATING	$T_A = 85^\circ\text{C}$ POWER RATING
DB	995 mW	8.0 mW/ $^\circ\text{C}$	635 mW	515 mW
DW	1480 mW	11.8 mW/ $^\circ\text{C}$	950 mW	770 mW

<sup>‡</sup> This is the inverse of the junction-to-ambient thermal resistance when board-mounted and with no air flow.

## recommended operating conditions

		MIN	NOM	MAX	UNIT
Supply voltage, $V_{CC}$		4.75	5	5.25	V
Voltage at any bus I/O terminal	A, B	–7		12	V
High-level input voltage, $V_{IH}$	D, DIR	2		$V_{CC}$	V
Low-level input voltage, $V_{IL}$		0		0.8	
Differential input voltage, $V_{ID}$	A with respect to B	–12		12	V
Output current	Driver	–60		60	mA
	Receiver	–8		8	
Operating free-air temperature, $T_A$	SN75LBC170	0		70	$^\circ\text{C}$
	SN65LBC170	–40		85	



# SN65LBC170, SN75LBC170 TRIPLE DIFFERENTIAL TRANSCEIVERS

SLLS459C – NOVEMBER 2000 – REVISED MARCH 2005

## DRIVER SECTION

### electrical characteristics over recommended operating conditions

PARAMETER		TEST CONDITIONS	MIN	TYP†	MAX	UNIT
$V_{IK}$	Input clamp voltage	D and DIR $I_I = 18 \text{ mA}$	-1.5	-0.7		V
$V_O$	Open-circuit output voltage (single-ended)	A or B, No load	0		$V_{CC}$	V
$ V_{OD(SS)} $	Steady-state differential output voltage magnitude‡	No load	3.8	4.3	$V_{CC}$	V
		$R_L = 54 \Omega$ , See Figure 1	1	1.6	2.4	
		With common-mode loading, See Figure 2	1	1.6	2.4	
$\Delta V_{OD}$	Change in differential output voltage magnitude, $ V_{OD(H)}  -  V_{OD(L)} $	$R_L = 54 \Omega$ , $C_L = 50 \text{ pF}$ See Figure 1	-0.2		0.2	V
$V_{OC(SS)}$	Steady-state common-mode output voltage		2	2.4	2.8	
$\Delta V_{OC(SS)}$	Change in steady-state common-mode output voltage ( $V_{OC(H)} - V_{OC(L)}$ )		-0.2		0.2	
$I_I$	Input current	D, DIR	-100		100	$\mu\text{A}$
$I_O$	Output current with power off	$V_{CC} = 0 \text{ V}$ , $V_O = -7 \text{ V to } 12 \text{ V}$	-700		900	$\mu\text{A}$
$I_{OS}$	Short-circuit output current	$V_O = -7 \text{ V to } 12 \text{ V}$ , See Figure 7	-250		250	mA
$I_{CC}$	Supply current (driver enabled)	D at 0 V or $V_{CC}$ , DIR at $V_{CC}$ , No load		14	20	mA

† All typical values are at  $V_{CC} = 5 \text{ V}$  and  $T_A = 25^\circ\text{C}$ .

‡ The minimum  $V_{OD}$  may not fully comply with TIA/EIA-485-A at operating temperatures below  $0^\circ\text{C}$ . System designers should take the possibly lower output signal into account in determining the maximum signal-transmission distance.

### switching characteristics over recommended operating conditions

PARAMETER		TEST CONDITIONS	MIN	TYP	MAX	UNIT
$t_{PLH}$	Differential output propagation delay, low-to-high	$R_L = 54 \Omega$ , $C_L = 50 \text{ pF}$ , See Figure 3	4	8.5	12	ns
$t_{PHL}$	Differential output propagation delay, high-to-low		4	8.5	11	
$t_r$	Differential output rise time		3	7.5	11	
$t_f$	Differential output fall time		3	7.5	11	
$t_{sk(p)}$	Pulse skew $ t_{PLH} - t_{PHL} $				2	
$t_{sk(o)}$	Output skew§				1.5	
$t_{sk(pp)}$	Part-to-part skew¶				2	
$t_{PLH}$	Differential output propagation delay, low-to-high	See Figure 4, (HVD SCSI double-terminated load)	3	7	10	ns
$t_{PHL}$	Differential output propagation delay, high-to-low		3	7.5	10	
$t_r$	Differential output rise time		3	7.5	12	
$t_f$	Differential output fall time		3	7.5	12	
$t_{sk(p)}$	Pulse skew $ t_{PLH} - t_{PHL} $				3	
$t_{sk(o)}$	Output skew§				1.5	
$t_{sk(pp)}$	Part-to-part skew¶				2.5	
$t_{pZH}$	Output enable time to high level	See Figure 5		15	25	ns
$t_{pHZ}$	Output disable time from high level			18	25	
$t_{pZL}$	Output enable time to low level	See Figure 6		10	25	ns
$t_{pLZ}$	Output disable time from low level			17	25	

§ Output skew ( $t_{sk(o)}$ ) is the magnitude of the time delay difference between the outputs of a single device with all of the inputs connected together.

¶ Part-to-part skew ( $t_{sk(pp)}$ ) is the magnitude of the difference in propagation delay times between any specified terminals of two devices when both devices operate with the same input signals, the same supply voltages, at the same temperature, and have identical packages and test circuits.



## RECEIVER SECTION

### electrical characteristics over recommended operating conditions

PARAMETER		TEST CONDITIONS	MIN	TYP†	MAX	UNIT
$V_{IT+}$	Positive-going differential input voltage threshold	See Figure 8			0.2	V
$V_{IT-}$	Negative-going differential input voltage threshold				-0.2	
$V_{hys}$	Hysteresis voltage ( $V_{IT+} - V_{IT-}$ )				40	mV
$V_{OH}$	High-level output voltage	$V_{ID} = 200$ mV, $I_{OH} = -8$ mA, See Figure 8	4	4.7	$V_{CC}$	V
$V_{OL}$	Low-level output voltage	$V_{ID} = -200$ mV, $I_{OL} = -8$ mA, See Figure 8	0	0.2	0.4	
$I_I$	Line input current	Other input = 0 V			0.9	mA
		$V_I = 12$ V				
		$V_I = -7$ V	-0.7			
$R_I$	Input resistance	A, B	12			k $\Omega$
$I_{CC}$	Supply current (receiver enabled)	A, B, D, and DIR open			16	mA

† All typical values are at  $V_{CC} = 5$  V and  $T_A = 25^\circ\text{C}$ .

### switching characteristics over recommended operating conditions

PARAMETER		TEST CONDITIONS	MIN	TYP	MAX	UNIT
$t_{PLH}$	Propagation delay time, low-to-high level output	See Figure 9	7		16	ns
$t_{PHL}$	Propagation delay time, high-to-low level output		7		16	
$t_r$	Receiver output rise time			1.3	3	ns
$t_f$	Receiver output fall time			1.3	3	
$t_{PZH}$	Receiver output enable time to high level	See Figure 10		26	40	ns
$t_{PHZ}$	Receiver output disable time from high level				40	
$t_{PZL}$	Receiver output enable time to low level	See Figure 11		29	40	ns
$t_{PLZ}$	Receiver output enable time to high level				40	
$t_{sk(p)}$	Pulse skew ( $ t_{PLH} - t_{PHL} $ )				2	ns
$t_{sk(o)}$	Output skew‡				1.5	ns
$t_{sk(pp)}$	Part-to-part skew§				3	ns

‡ Output skew ( $t_{sk(o)}$ ) is the magnitude of the time delay difference between the outputs of a single device with all of the inputs connected together.

§ Part-to-part skew ( $t_{sk(pp)}$ ) is the magnitude of the difference in propagation delay times between any specified terminals of two devices when both devices operate with the same input signals, the same supply voltages, at the same temperature, and have identical packages and test circuits.

# SN65LBC170, SN75LBC170 TRIPLE DIFFERENTIAL TRANSCIEVERS

SLLS459C – NOVEMBER 2000 – REVISED MARCH 2005

## PARAMETER MEASUREMENT INFORMATION

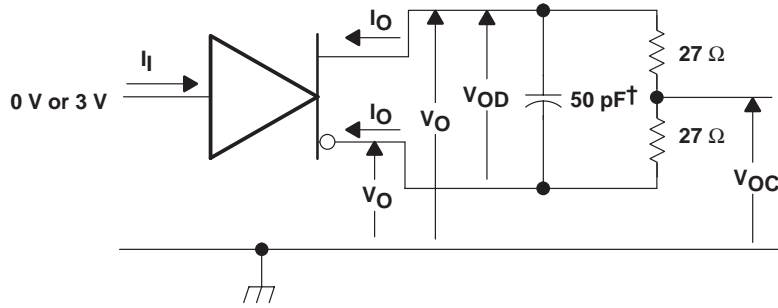

† Includes probe and jig capacitance

Figure 1. Driver Test Circuit,  $V_{OD}$  and  $V_{OC}$  Without Common-Mode Loading

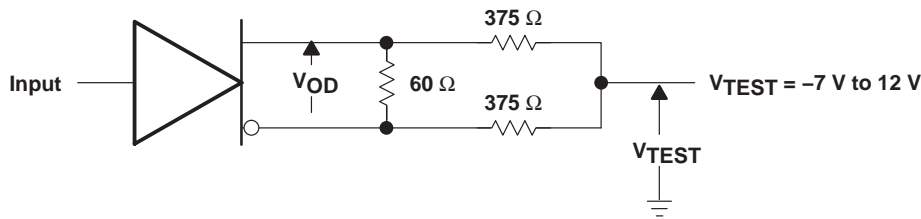
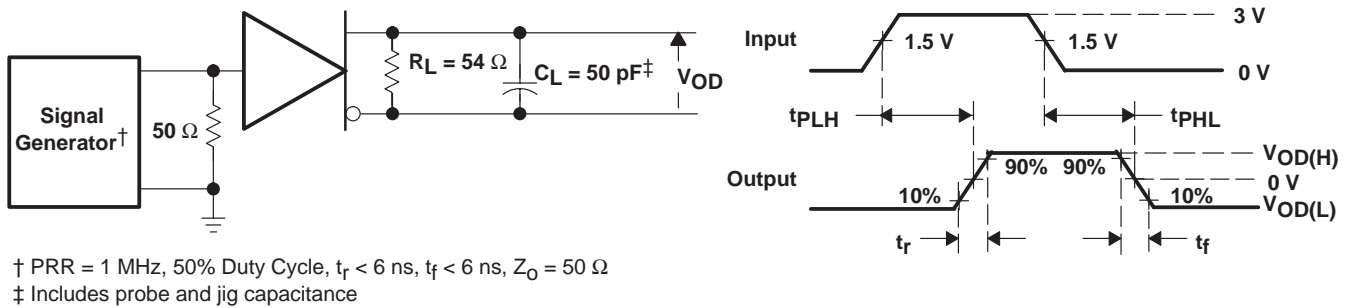

Figure 2. Driver Test Circuit,  $V_{OD}$  With Common-Mode Loading



† PRR = 1 MHz, 50% Duty Cycle,  $t_r < 6$  ns,  $t_f < 6$  ns,  $Z_0 = 50 \Omega$

‡ Includes probe and jig capacitance

Figure 3. Driver Switching Test Circuit and Waveforms, 485-Loading

## PARAMETER MEASUREMENT INFORMATION

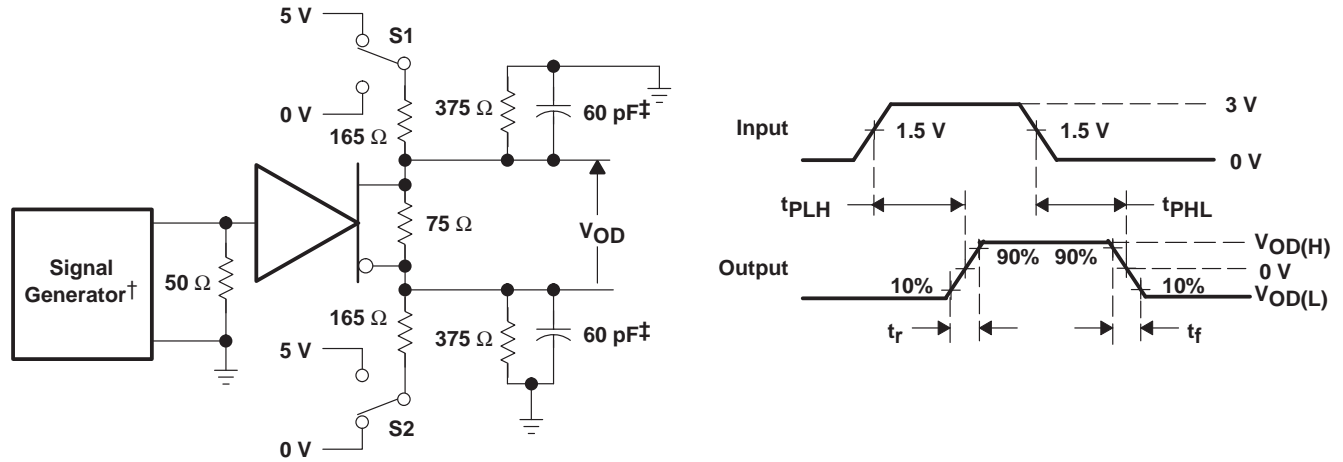

† PRR = 1 MHz, 50% Duty Cycle,  $t_r < 6$  ns,  $t_f < 6$  ns,  $Z_0 = 50 \Omega$   
‡ Includes probe and jig capacitance

Figure 4. Driver Switching Test Circuit and Waveforms, HVD SCSI-Loading (double terminated)

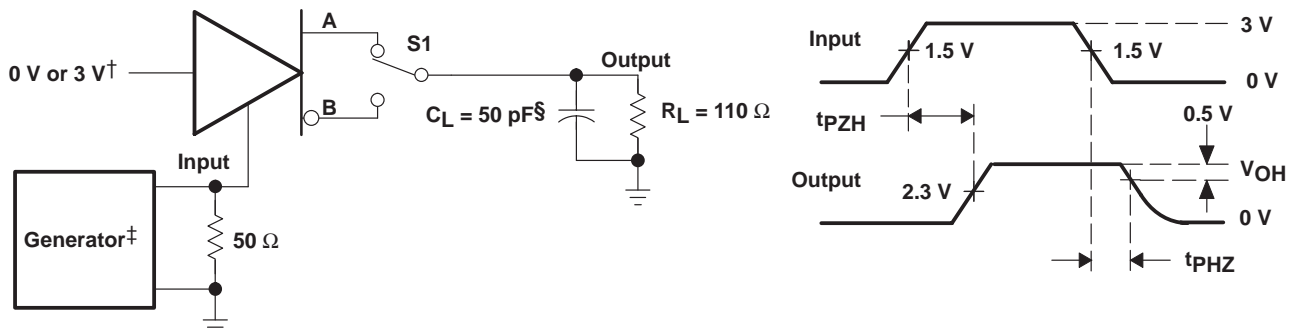

† 3 V if testing A output, 0 V if testing B output  
‡ PRR = 1 MHz, 50% Duty Cycle,  $t_r < 6$  ns,  $t_f < 6$  ns,  $Z_0 = 50 \Omega$   
§ Includes probe and jig capacitance

Figure 5. Driver Enable/Disable Test, High Output

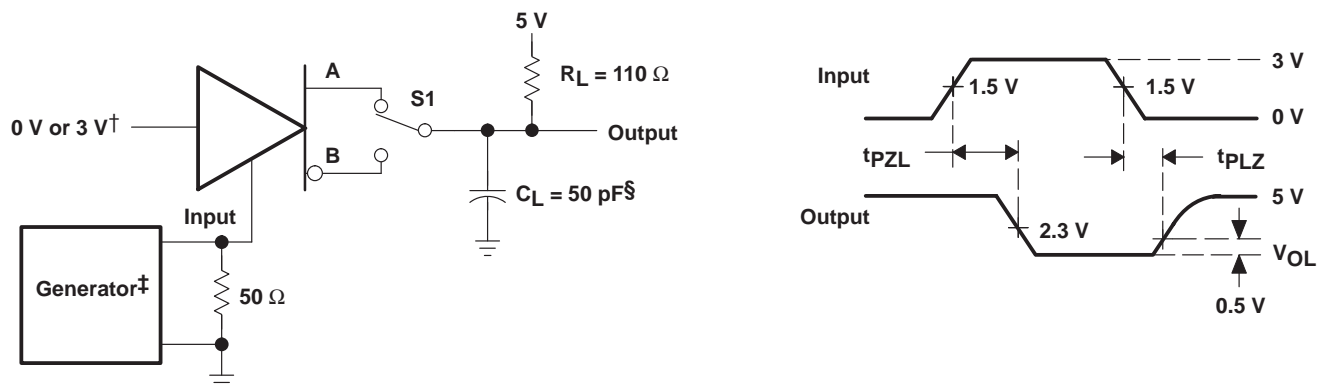

† 0 V if testing A output, 3 V if testing B output  
‡ PRR = 1 MHz, 50% Duty Cycle,  $t_r < 6$  ns,  $t_f < 6$  ns,  $Z_0 = 50 \Omega$   
§ Includes probe and jig capacitance

Figure 6. Driver Enable/Disable Test, Low Output

# SN65LBC170, SN75LBC170 TRIPLE DIFFERENTIAL TRANSCIEVERS

SLLS459C – NOVEMBER 2000 – REVISED MARCH 2005

## PARAMETER MEASUREMENT INFORMATION

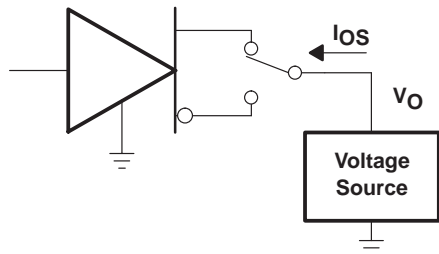

Figure 7. Driver Short-Circuit Test

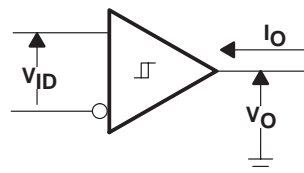
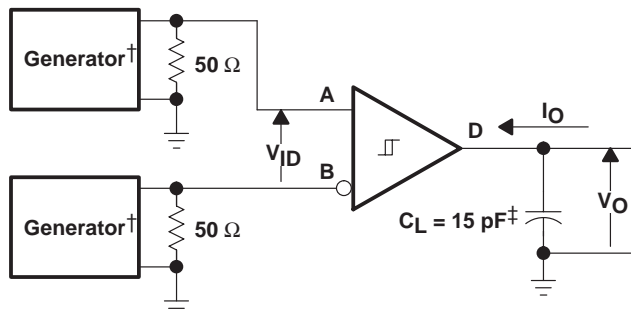
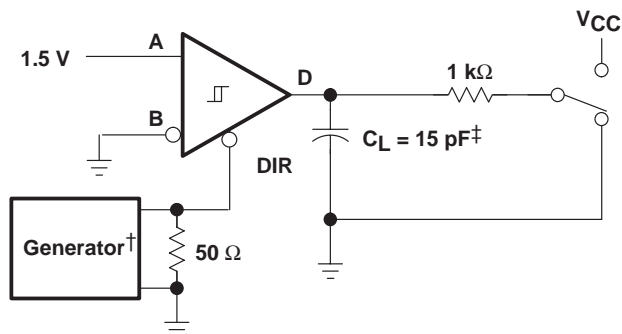

Figure 8. Receiver DC Parameters



† PRR = 1 MHz, 50% Duty Cycle,  $t_r < 6$  ns,  $t_f < 6$  ns,  $Z_0 = 50 \Omega$   
‡ Includes probe and jig capacitance

Figure 9. Receiver Switching Test Circuit and Waveforms



† PRR = 1 MHz, 50% Duty Cycle,  $t_r < 6$  ns,  $t_f < 6$  ns,  $Z_0 = 50 \Omega$   
‡ Includes probe and jig capacitance

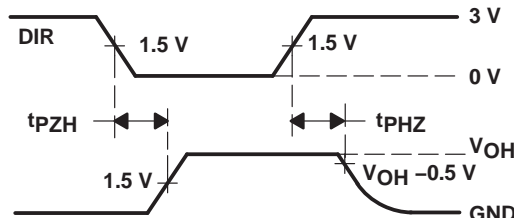
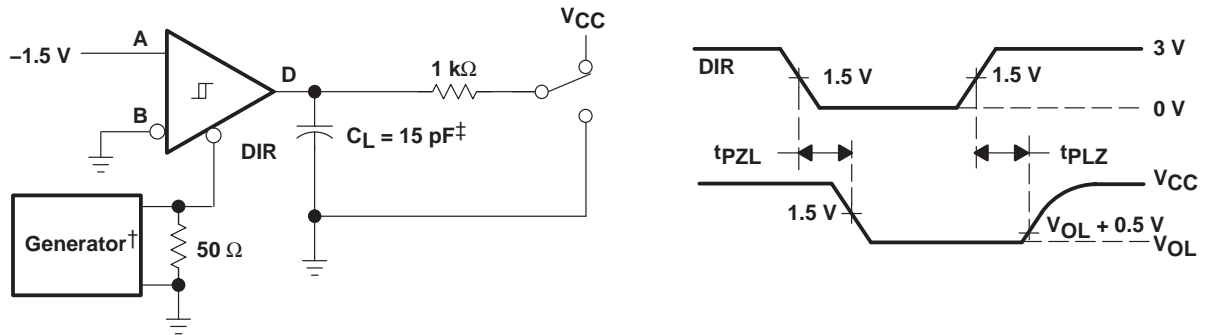

Figure 10. Receiver Enable/Disable Test, High Output

## PARAMETER MEASUREMENT INFORMATION



† PRR = 1 MHz, 50% Duty Cycle,  $t_r < 6$  ns,  $t_f < 6$  ns,  $Z_0 = 50 \Omega$   
 ‡ Includes probe and jig capacitance

Figure 11. Receiver Enable/Disable Test, Low Output

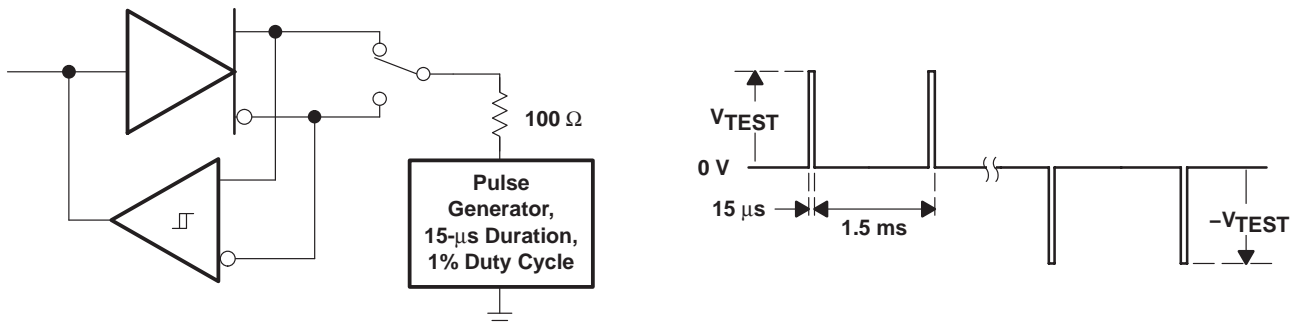

Figure 12. Test Circuit and Waveform, Transient Over Voltage Test

# SN65LBC170, SN75LBC170 TRIPLE DIFFERENTIAL TRANSCEIVERS

SLLS459C – NOVEMBER 2000 – REVISED MARCH 2005

## TYPICAL CHARACTERISTICS

DIFFERENTIAL OUTPUT VOLTAGE  
vs  
OUTPUT CURRENT

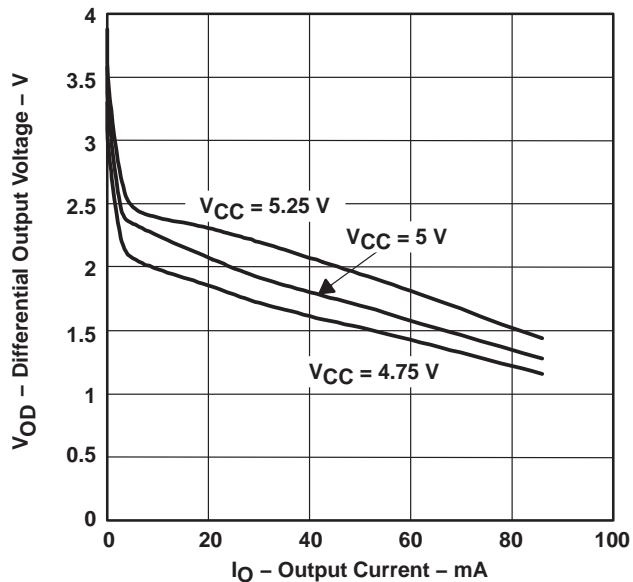

Figure 13

DIFFERENTIAL OUTPUT VOLTAGE  
vs  
FREE-AIR TEMPERATURE

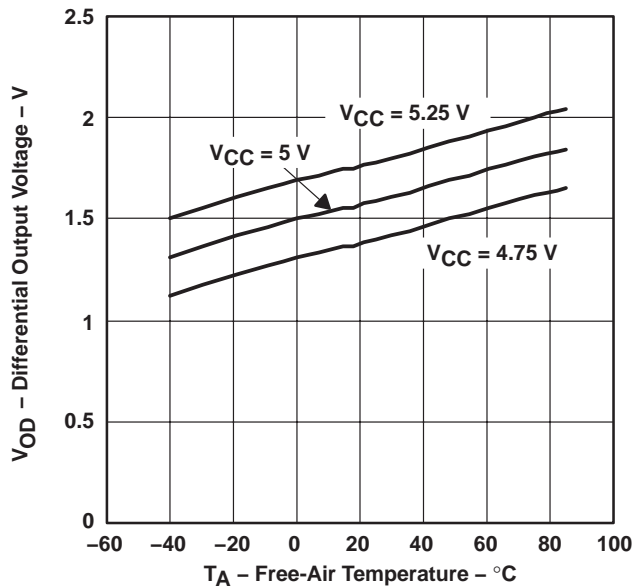

Figure 14

DRIVER PROPAGATION DELAY  
vs  
FREE-AIR TEMPERATURE

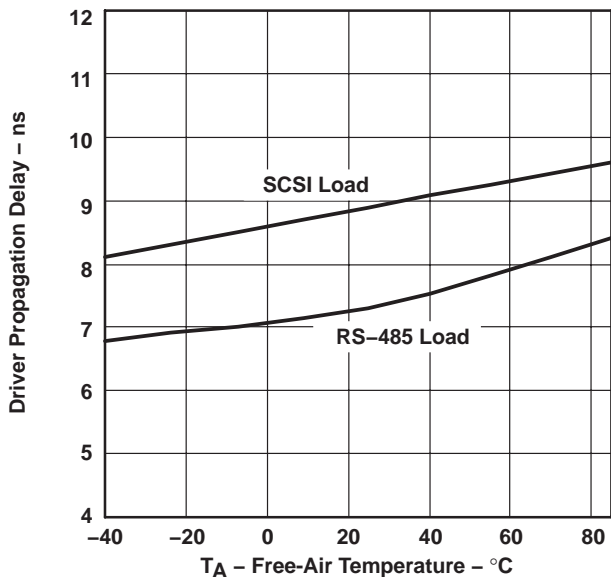

Figure 15

SUPPLY CURRENT  
vs  
SIGNALING RATE

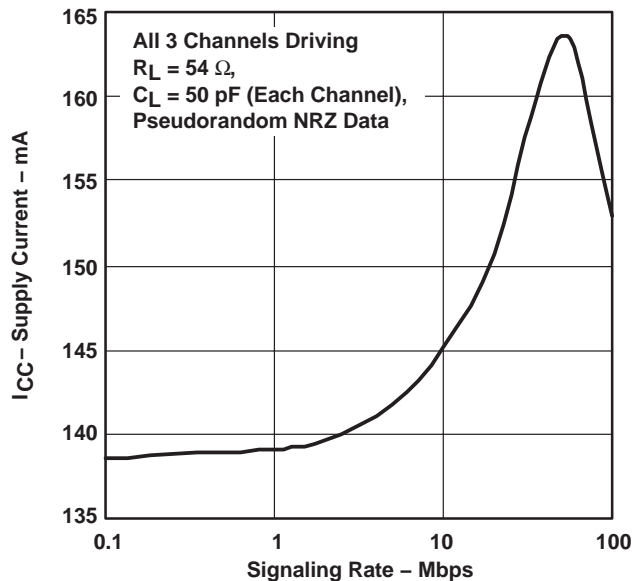

Figure 16



TYPICAL CHARACTERISTICS

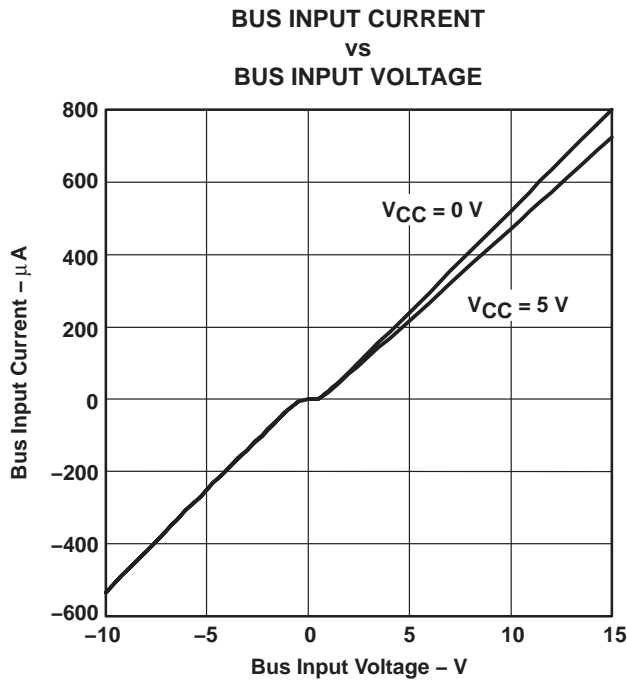

Figure 17

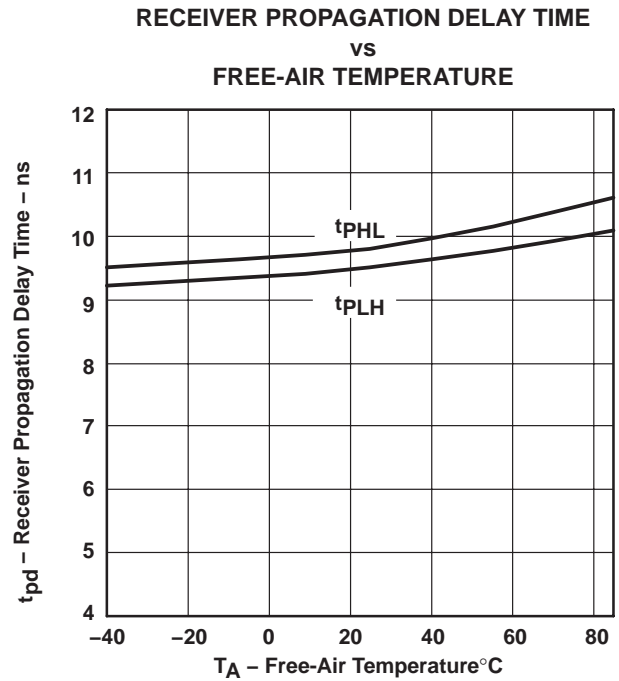

Figure 18

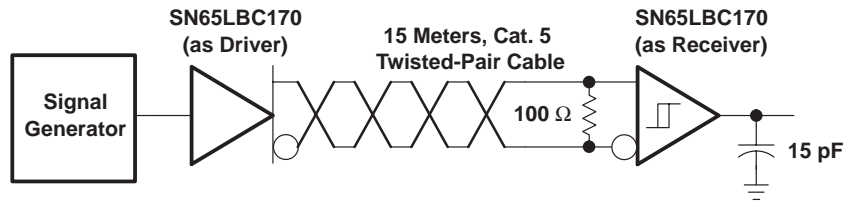

Figure 19. Circuit Diagram for Signaling Characteristics

# SN65LBC170, SN75LBC170 TRIPLE DIFFERENTIAL TRANSCEIVERS

SLLS459C – NOVEMBER 2000 – REVISED MARCH 2005

## TYPICAL CHARACTERISTICS

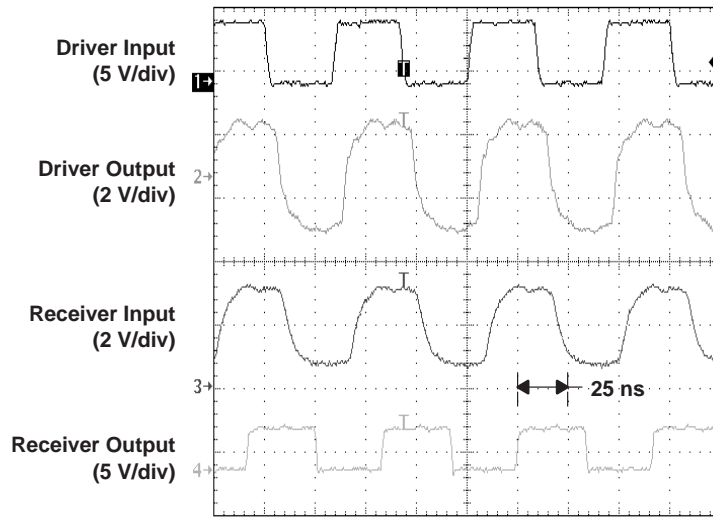

Figure 20. Signal Waveforms at 30 Mbps

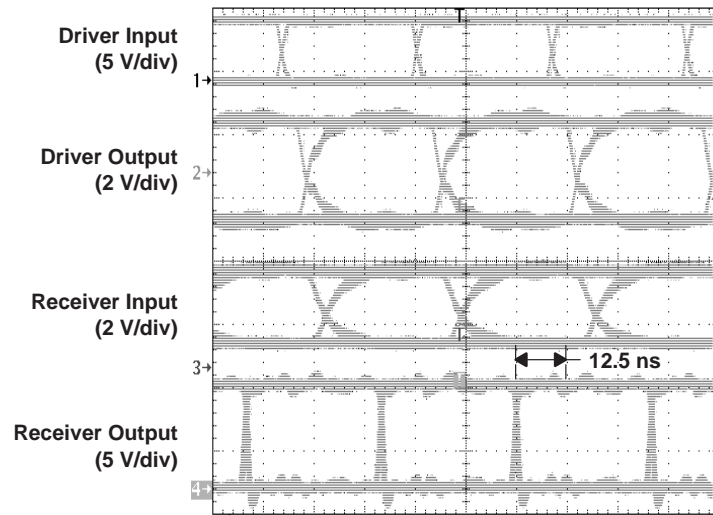

Figure 21. Eye Patterns, Pseudorandom Data at 30 Mbps

TYPICAL CHARACTERISTICS

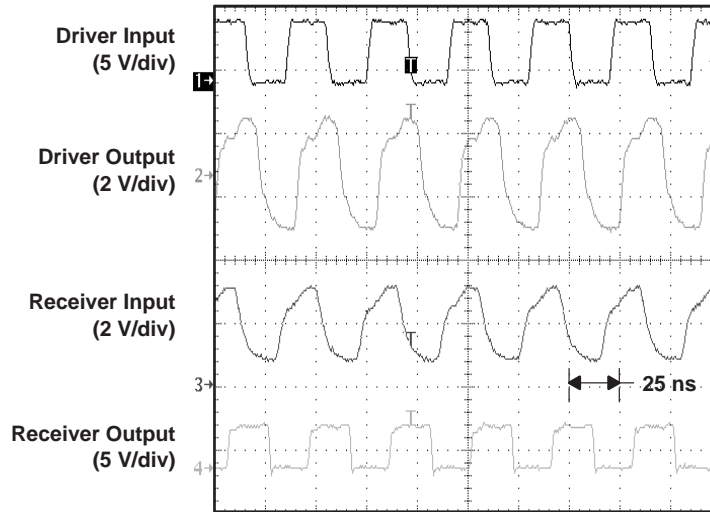

Figure 22. Signal Waveforms at 50 Mbps

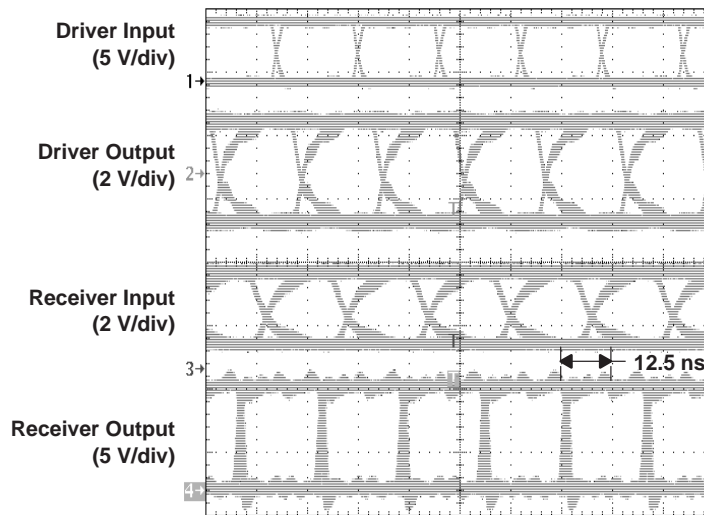

Figure 23. Eye Patterns, Pseudorandom Data at 50 Mbps

**PACKAGING INFORMATION**

Orderable Device	Status (1)	Package Type	Package Drawing	Pins	Package Qty	Eco Plan (2)	Lead/Ball Finish (6)	MSL Peak Temp (3)	Op Temp (°C)	Device Marking (4/5)	Samples
SN65LBC170DB	ACTIVE	SSOP	DB	16	80	Green (RoHS & no Sb/Br)	CU NIPDAU	Level-1-260C-UNLIM	-40 to 85	BL170	<a href="#">Samples</a>
SN65LBC170DBR	ACTIVE	SSOP	DB	16	2000	Green (RoHS & no Sb/Br)	CU NIPDAU	Level-1-260C-UNLIM	-40 to 85	BL170	<a href="#">Samples</a>
SN65LBC170DW	ACTIVE	SOIC	DW	20	25	Green (RoHS & no Sb/Br)	CU NIPDAU	Level-1-260C-UNLIM	-40 to 85	65LBC170	<a href="#">Samples</a>
SN75LBC170DB	ACTIVE	SSOP	DB	16	80	Green (RoHS & no Sb/Br)	CU NIPDAU	Level-1-260C-UNLIM	0 to 70	LB170	<a href="#">Samples</a>
SN75LBC170DBR	ACTIVE	SSOP	DB	16	2000	Green (RoHS & no Sb/Br)	CU NIPDAU	Level-1-260C-UNLIM	0 to 70	LB170	<a href="#">Samples</a>
SN75LBC170DBRG4	ACTIVE	SSOP	DB	16	2000	Green (RoHS & no Sb/Br)	CU NIPDAU	Level-1-260C-UNLIM	0 to 70	LB170	<a href="#">Samples</a>

(1) The marketing status values are defined as follows:

**ACTIVE:** Product device recommended for new designs.

**LIFEBUY:** TI has announced that the device will be discontinued, and a lifetime-buy period is in effect.

**NRND:** Not recommended for new designs. Device is in production to support existing customers, but TI does not recommend using this part in a new design.

**PREVIEW:** Device has been announced but is not in production. Samples may or may not be available.

**OBSELETE:** TI has discontinued the production of the device.

(2) Eco Plan - The planned eco-friendly classification: Pb-Free (RoHS), Pb-Free (RoHS Exempt), or Green (RoHS & no Sb/Br) - please check <http://www.ti.com/productcontent> for the latest availability information and additional product content details.

**TBD:** The Pb-Free/Green conversion plan has not been defined.

**Pb-Free (RoHS):** TI's terms "Lead-Free" or "Pb-Free" mean semiconductor products that are compatible with the current RoHS requirements for all 6 substances, including the requirement that lead not exceed 0.1% by weight in homogeneous materials. Where designed to be soldered at high temperatures, TI Pb-Free products are suitable for use in specified lead-free processes.

**Pb-Free (RoHS Exempt):** This component has a RoHS exemption for either 1) lead-based flip-chip solder bumps used between the die and package, or 2) lead-based die adhesive used between the die and leadframe. The component is otherwise considered Pb-Free (RoHS compatible) as defined above.

**Green (RoHS & no Sb/Br):** TI defines "Green" to mean Pb-Free (RoHS compatible), and free of Bromine (Br) and Antimony (Sb) based flame retardants (Br or Sb do not exceed 0.1% by weight in homogeneous material)

(3) MSL, Peak Temp. - The Moisture Sensitivity Level rating according to the JEDEC industry standard classifications, and peak solder temperature.

(4) There may be additional marking, which relates to the logo, the lot trace code information, or the environmental category on the device.

(5) Multiple Device Markings will be inside parentheses. Only one Device Marking contained in parentheses and separated by a "~" will appear on a device. If a line is indented then it is a continuation of the previous line and the two combined represent the entire Device Marking for that device.

<sup>(6)</sup> Lead/Ball Finish - Orderable Devices may have multiple material finish options. Finish options are separated by a vertical ruled line. Lead/Ball Finish values may wrap to two lines if the finish value exceeds the maximum column width.

**Important Information and Disclaimer:** The information provided on this page represents TI's knowledge and belief as of the date that it is provided. TI bases its knowledge and belief on information provided by third parties, and makes no representation or warranty as to the accuracy of such information. Efforts are underway to better integrate information from third parties. TI has taken and continues to take reasonable steps to provide representative and accurate information but may not have conducted destructive testing or chemical analysis on incoming materials and chemicals. TI and TI suppliers consider certain information to be proprietary, and thus CAS numbers and other limited information may not be available for release.

In no event shall TI's liability arising out of such information exceed the total purchase price of the TI part(s) at issue in this document sold by TI to Customer on an annual basis.

**TAPE AND REEL INFORMATION**

**QUADRANT ASSIGNMENTS FOR PIN 1 ORIENTATION IN TAPE**

\*All dimensions are nominal

Device	Package Type	Package Drawing	Pins	SPQ	Reel Diameter (mm)	Reel Width W1 (mm)	A0 (mm)	B0 (mm)	K0 (mm)	P1 (mm)	W (mm)	Pin1 Quadrant
SN65LBC170DBR	SSOP	DB	16	2000	330.0	16.4	8.2	6.6	2.5	12.0	16.0	Q1
SN75LBC170DBR	SSOP	DB	16	2000	330.0	16.4	8.2	6.6	2.5	12.0	16.0	Q1

**TAPE AND REEL BOX DIMENSIONS**

\*All dimensions are nominal

Device	Package Type	Package Drawing	Pins	SPQ	Length (mm)	Width (mm)	Height (mm)
SN65LBC170DBR	SSOP	DB	16	2000	367.0	367.0	38.0
SN75LBC170DBR	SSOP	DB	16	2000	367.0	367.0	38.0

DW (R-PDSO-G20)

PLASTIC SMALL OUTLINE

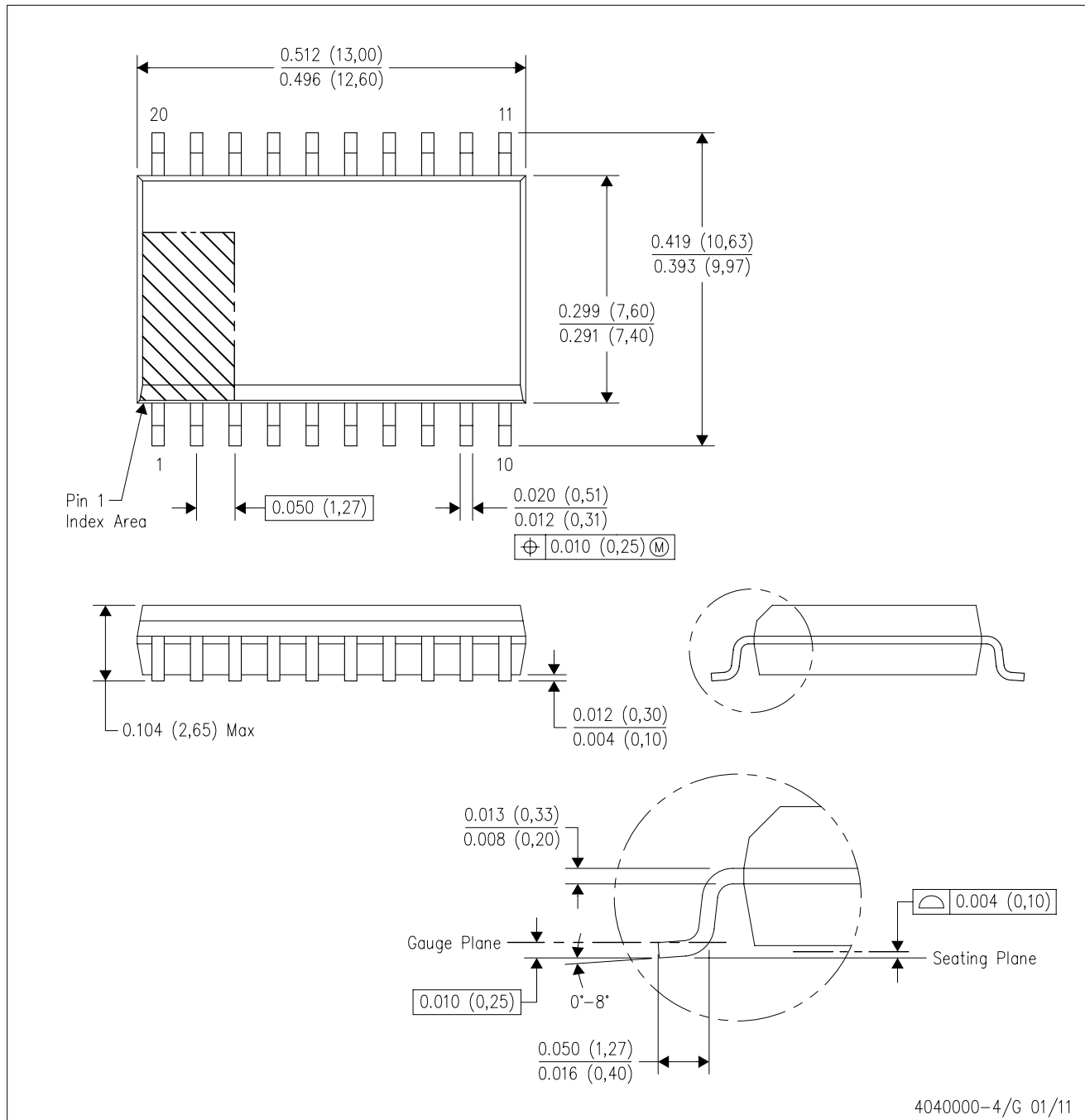

- NOTES:
- A. All linear dimensions are in inches (millimeters). Dimensioning and tolerancing per ASME Y14.5M-1994.
  - B. This drawing is subject to change without notice.
  - C. Body dimensions do not include mold flash or protrusion not to exceed 0.006 (0,15).
  - D. Falls within JEDEC MS-013 variation AC.

DW (R-PDSO-G20)

PLASTIC SMALL OUTLINE

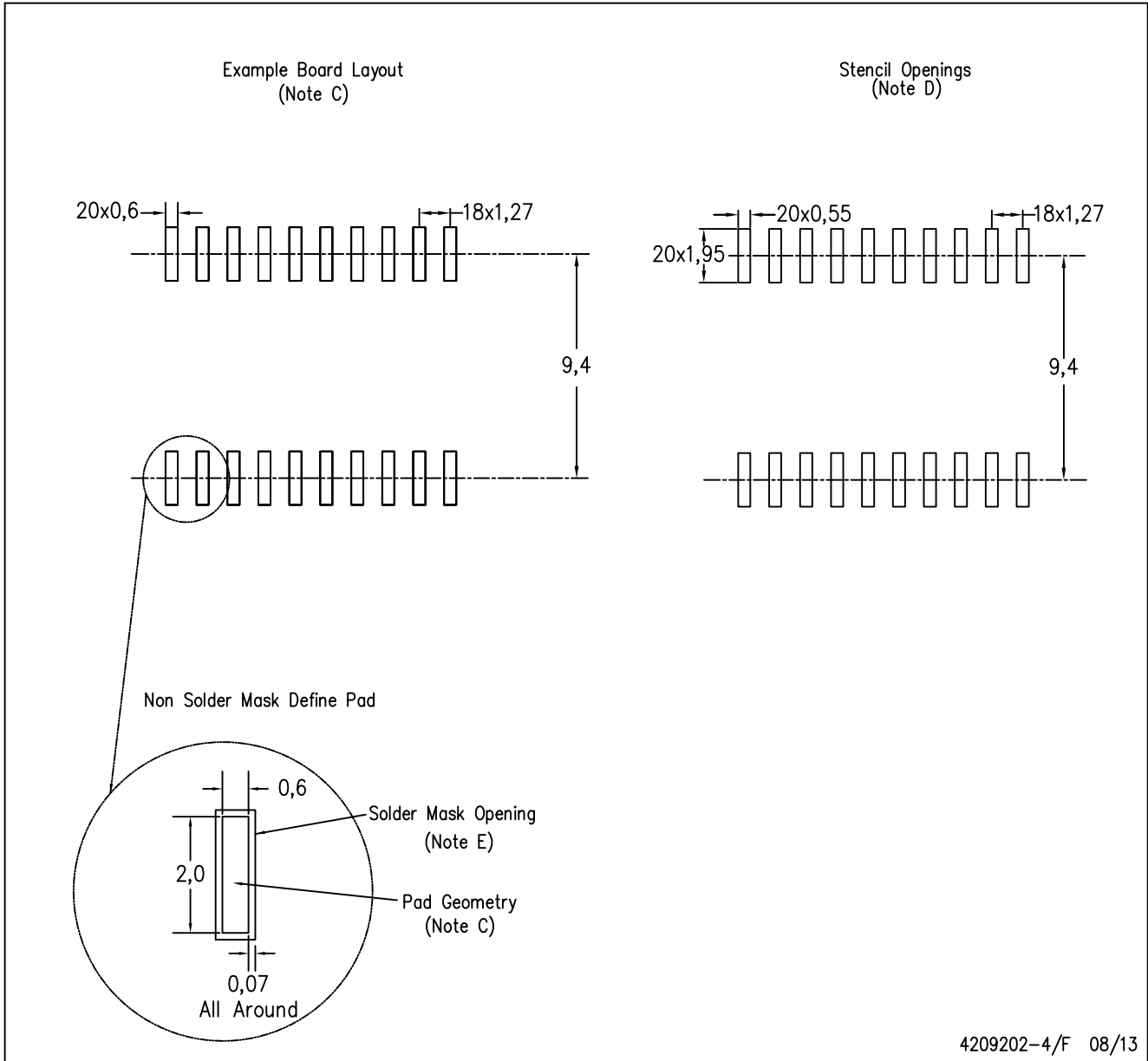

- NOTES:
- A. All linear dimensions are in millimeters.
  - B. This drawing is subject to change without notice.
  - C. Refer to IPC7351 for alternate board design.
  - D. Laser cutting apertures with trapezoidal walls and also rounding corners will offer better paste release. Customers should contact their board assembly site for stencil design recommendations. Refer to IPC-7525
  - E. Customers should contact their board fabrication site for solder mask tolerances between and around signal pads.

DB (R-PDSO-G\*\*)

PLASTIC SMALL-OUTLINE

28 PINS SHOWN



- NOTES: A. All linear dimensions are in millimeters.  
 B. This drawing is subject to change without notice.  
 C. Body dimensions do not include mold flash or protrusion not to exceed 0,15.  
 D. Falls within JEDEC MO-150

## IMPORTANT NOTICE

Texas Instruments Incorporated and its subsidiaries (TI) reserve the right to make corrections, enhancements, improvements and other changes to its semiconductor products and services per JESD46, latest issue, and to discontinue any product or service per JESD48, latest issue. Buyers should obtain the latest relevant information before placing orders and should verify that such information is current and complete. All semiconductor products (also referred to herein as "components") are sold subject to TI's terms and conditions of sale supplied at the time of order acknowledgment.

TI warrants performance of its components to the specifications applicable at the time of sale, in accordance with the warranty in TI's terms and conditions of sale of semiconductor products. Testing and other quality control techniques are used to the extent TI deems necessary to support this warranty. Except where mandated by applicable law, testing of all parameters of each component is not necessarily performed.

TI assumes no liability for applications assistance or the design of Buyers' products. Buyers are responsible for their products and applications using TI components. To minimize the risks associated with Buyers' products and applications, Buyers should provide adequate design and operating safeguards.

TI does not warrant or represent that any license, either express or implied, is granted under any patent right, copyright, mask work right, or other intellectual property right relating to any combination, machine, or process in which TI components or services are used. Information published by TI regarding third-party products or services does not constitute a license to use such products or services or a warranty or endorsement thereof. Use of such information may require a license from a third party under the patents or other intellectual property of the third party, or a license from TI under the patents or other intellectual property of TI.

Reproduction of significant portions of TI information in TI data books or data sheets is permissible only if reproduction is without alteration and is accompanied by all associated warranties, conditions, limitations, and notices. TI is not responsible or liable for such altered documentation. Information of third parties may be subject to additional restrictions.

Resale of TI components or services with statements different from or beyond the parameters stated by TI for that component or service voids all express and any implied warranties for the associated TI component or service and is an unfair and deceptive business practice. TI is not responsible or liable for any such statements.

Buyer acknowledges and agrees that it is solely responsible for compliance with all legal, regulatory and safety-related requirements concerning its products, and any use of TI components in its applications, notwithstanding any applications-related information or support that may be provided by TI. Buyer represents and agrees that it has all the necessary expertise to create and implement safeguards which anticipate dangerous consequences of failures, monitor failures and their consequences, lessen the likelihood of failures that might cause harm and take appropriate remedial actions. Buyer will fully indemnify TI and its representatives against any damages arising out of the use of any TI components in safety-critical applications.

In some cases, TI components may be promoted specifically to facilitate safety-related applications. With such components, TI's goal is to help enable customers to design and create their own end-product solutions that meet applicable functional safety standards and requirements. Nonetheless, such components are subject to these terms.

No TI components are authorized for use in FDA Class III (or similar life-critical medical equipment) unless authorized officers of the parties have executed a special agreement specifically governing such use.

Only those TI components which TI has specifically designated as military grade or "enhanced plastic" are designed and intended for use in military/aerospace applications or environments. Buyer acknowledges and agrees that any military or aerospace use of TI components which have **not** been so designated is solely at the Buyer's risk, and that Buyer is solely responsible for compliance with all legal and regulatory requirements in connection with such use.

TI has specifically designated certain components as meeting ISO/TS16949 requirements, mainly for automotive use. In any case of use of non-designated products, TI will not be responsible for any failure to meet ISO/TS16949.

### Products

Audio	<a href="http://www.ti.com/audio">www.ti.com/audio</a>
Amplifiers	<a href="http://amplifier.ti.com">amplifier.ti.com</a>
Data Converters	<a href="http://dataconverter.ti.com">dataconverter.ti.com</a>
DLP® Products	<a href="http://www.dlp.com">www.dlp.com</a>
DSP	<a href="http://dsp.ti.com">dsp.ti.com</a>
Clocks and Timers	<a href="http://www.ti.com/clocks">www.ti.com/clocks</a>
Interface	<a href="http://interface.ti.com">interface.ti.com</a>
Logic	<a href="http://logic.ti.com">logic.ti.com</a>
Power Mgmt	<a href="http://power.ti.com">power.ti.com</a>
Microcontrollers	<a href="http://microcontroller.ti.com">microcontroller.ti.com</a>
RFID	<a href="http://www.ti-rfid.com">www.ti-rfid.com</a>
OMAP Applications Processors	<a href="http://www.ti.com/omap">www.ti.com/omap</a>
Wireless Connectivity	<a href="http://www.ti.com/wirelessconnectivity">www.ti.com/wirelessconnectivity</a>

### Applications

Automotive and Transportation	<a href="http://www.ti.com/automotive">www.ti.com/automotive</a>
Communications and Telecom	<a href="http://www.ti.com/communications">www.ti.com/communications</a>
Computers and Peripherals	<a href="http://www.ti.com/computers">www.ti.com/computers</a>
Consumer Electronics	<a href="http://www.ti.com/consumer-apps">www.ti.com/consumer-apps</a>
Energy and Lighting	<a href="http://www.ti.com/energy">www.ti.com/energy</a>
Industrial	<a href="http://www.ti.com/industrial">www.ti.com/industrial</a>
Medical	<a href="http://www.ti.com/medical">www.ti.com/medical</a>
Security	<a href="http://www.ti.com/security">www.ti.com/security</a>
Space, Avionics and Defense	<a href="http://www.ti.com/space-avionics-defense">www.ti.com/space-avionics-defense</a>
Video and Imaging	<a href="http://www.ti.com/video">www.ti.com/video</a>

### TI E2E Community

[e2e.ti.com](http://e2e.ti.com)