



# Numonyx<sup>®</sup> Embedded Flash Memory (J3 65 nm) Single Bit per Cell (SBC)

32, 64, and 128 Mbit

Datasheet

## Product Features

- Architecture
  - Symmetrical 128-KB blocks
  - 128 Mbit (128 blocks)
  - 64 Mbit (64 blocks)
  - 32 Mbit (32 blocks)
  - Blank Check to verify an erased block
- Performance
  - Initial Access Speed: 75ns
  - 25 ns 8-word Asynchronous page-mode reads
  - 256-Word write buffer for x16 mode, 256-Byte write buffer for x8 mode; 1.41  $\mu$ s per Byte Effective programming time
- System Voltage
  - $V_{CC}$  = 2.7 V to 3.6 V
  - $V_{CCQ}$  = 2.7 V to 3.6 V
- Packaging
  - 56-Lead TSOP
  - 64-Ball Easy BGA package
- Security
  - Enhanced security options for code protection
  - Absolute protection with  $V_{PEN} = V_{SS}$
  - Individual block locking
  - Block erase/program lockout during power transitions
  - Password Access feature
  - One-Time Programmable Register: 64 OTP bits, programmed with unique information by Numonyx  
64 OTP bits, available for customer programming
- Software
  - Program and erase suspend support
  - Numonyx<sup>®</sup> Flash Data Integrator (FDI)
  - Common Flash Interface (CFI) Compatible
  - Scalable Command Set
- Quality and Reliability
  - Operating temperature: -40 °C to +85 °C
  - 100K Minimum erase cycles per block
  - 65 nm Flash Technology
  - JESD47E Compliant



## Contents

---

<b>1.0</b>	<b>Introduction</b>	6
1.1	Nomenclature	6
1.2	Acronyms	7
1.3	Conventions	7
<b>2.0</b>	<b>Functional Overview</b>	9
2.1	Block Diagram	11
2.2	Memory Map	12
<b>3.0</b>	<b>Package Information</b>	13
3.1	56-Lead TSOP Package for 32-, 64-, 128-Mbit	13
3.2	64-Ball Easy BGA Package for 32-, 64-, 128-Mbit	14
<b>4.0</b>	<b>Ballouts/Pinouts and Signal Descriptions</b>	16
4.1	Easy BGA Ballout for 32-, 64-, 128-Mbit	16
4.2	56-Lead TSOP Package Pinout for 32-, 64-, 128-Mbit	17
4.3	Signal Descriptions	18
<b>5.0</b>	<b>Maximum Ratings and Operating Conditions</b>	19
5.1	Absolute Maximum Ratings	19
5.2	Operating Conditions	19
5.3	Power-Up/Down	19
	5.3.1 Power-Up/Down Sequence	19
	5.3.2 Power Supply Decoupling	20
5.4	Reset	20
<b>6.0</b>	<b>Electrical Characteristics</b>	21
6.1	DC Current Specifications	21
6.2	DC Voltage specifications	22
6.3	Capacitance	22
<b>7.0</b>	<b>AC Characteristics</b>	23
7.1	Read Specifications	24
7.2	Program, Erase, Block-Lock Specifications	28
7.3	Reset Specifications	28
7.4	AC Test Conditions	29
<b>8.0</b>	<b>Bus Interface</b>	30
8.1	Bus Reads	31
	8.1.1 Asynchronous Page Mode Read	31
	8.1.2 Output Disable	32
8.2	Bus Writes	32
8.3	Standby	33
	8.3.1 Reset/Power-Down	33
8.4	Device Commands	33
<b>9.0</b>	<b>Flash Operations</b>	34
9.1	Status Register	34
	9.1.1 Clearing the Status Register	35
9.2	Read Operations	35
	9.2.1 Read Array	35
	9.2.2 Read Status Register	36
	9.2.3 Read Device Information	36
	9.2.4 CFI Query	36
9.3	Programming Operations	36

9.3.1	Single-Word/Byte Programming .....	36
9.3.2	Buffered Programming .....	37
9.4	Block Erase Operations .....	38
9.5	Blank Check .....	39
9.6	Suspend and Resume .....	39
9.7	Status Signal .....	41
9.8	Security and Protection.....	42
9.8.1	Normal Block Locking .....	42
9.8.2	Configurable Block Locking.....	43
9.8.3	Password Access.....	43
9.8.4	128-bit OTP Protection Register .....	43
9.8.5	Reading the 128-bit OTP Protection Register.....	43
9.8.6	Programming the 128-bit OTP Protection Register .....	43
9.8.7	Locking the 128-bit OTP Protection Register .....	44
9.8.8	VPEN Protection.....	45
<b>10.0</b>	<b>ID Codes .....</b>	<b>46</b>
<b>11.0</b>	<b>Device Command Codes .....</b>	<b>47</b>
<b>12.0</b>	<b>Flow Charts .....</b>	<b>48</b>
<b>13.0</b>	<b>Common Flash Interface .....</b>	<b>57</b>
13.1	Query Structure Output .....	57
13.2	Query Structure Overview.....	58
13.3	Block Status Register .....	59
13.4	CFI Query Identification String .....	59
13.5	System Interface Information.....	60
13.6	Device Geometry Definition.....	60
13.7	Primary-Vendor Specific Extended Query Table .....	61
<b>A</b>	<b>Additional Information .....</b>	<b>64</b>
<b>B</b>	<b>Ordering Information .....</b>	<b>65</b>

## Revision History

---

Date	Revision	Description
May 2009	01	Initial release
March 2010	02	<p>Add Blank Check function and command.</p> <p>Add Blank Check specification tBC/MB, update Clear Block Lock-Bits Max Time and Program time in Table 13, "Configuration Performance" on page 28.</p> <p>Update I<sub>CCR</sub> in Table 7, "DC Current Characteristics" on page 21.</p> <p>Order information with device features digit.</p> <p>Update part number information in Valid Combination table.</p> <p>Add a note to clarify the SR output after E8 command in Figure 16, "Write to Buffer Flowchart" on page 48.</p> <p>State JESD47E Compliant at front page.</p> <p>Update ECR.13 description in Table 18, "Enhanced Configuration Register" on page 32.</p>
Jan 2011	03	<p>Correct the typo of comment for offset 24h at CFI from 2048μs to 1024μs.</p> <p>Correct the typo of t<sub>AVOQ</sub> and t<sub>ELQV</sub> to Max Specifications.</p> <p>Emphasize the valid and legal command usage at Section 11.0, "Device Command Codes" on page 47.</p> <p>Put a link for part numbers after Table 46, "Valid Combinations" on page 65.</p> <p>Add Buffer Program Time for 128 Words (256 Bytes) at Table 13, "Configuration Performance" on page 28.</p> <p>Add JEDEC standard lead width for TSOP56 package at Table 1, "56-Lead TSOP Dimension Table" on page 13.</p>

## 1.0 Introduction

This document contains information pertaining to the Numonyx® Embedded Flash Memory (J3 65 nm) Single Bit per Cell (SBC) device features, operation, and specifications.

Unless otherwise indicated throughout the rest of this document, the Numonyx® Embedded Flash Memory (J3 65 nm) Single Bit per Cell (SBC) device is referred to as J3 65 nm SBC.

The J3 65 nm SBC device provides improved mainstream performance with enhanced security features, taking advantage of the high quality and reliability of the NOR-based 65 nm technology. Offered in 128-Mbit, 64-Mbit, and 32-Mbit densities, the J3 65 nm SBC device brings reliable, low-voltage capability (3 V read, program, and erase) with high speed, low-power operation. The J3 65 nm SBC device takes advantage of proven manufacturing experience and is ideal for code and data applications where high density and low cost are required, such as in networking, telecommunications, digital set top boxes, audio recording, and digital imaging. Numonyx Flash Memory components also deliver a new generation of forward-compatible software support. By using the Common Flash Interface (CFI) and Scalable Command Set (SCS), customers can take advantage of density upgrades and optimized write capabilities of future Numonyx Flash Memory devices.

## 1.1 Nomenclature

<b>J3 65 nm SBC</b>	Numonyx® Embedded Flash Memory (J3 65 nm) Single Bit per Cell (SBC)	
<b>AMIN</b>	All Densities	AMIN = A0 for x8
	All Densities	AMIN = A1 for x16
<b>AMAX</b>	32 Mbit	AMAX = A21
	64 Mbit	AMAX = A22
	128 Mbit	AMAX = A23
<b>Block</b>	A group of flash cells that share common erase circuitry and erase simultaneously.	
<b>Clear</b>	Indicates a logic zero (0)	
<b>Program</b>	Writes data to the flash array	
<b>Set</b>	Indicates a logic one (1)	
<b>VPEN</b>	Refers to a signal or package connection name	
<b>V<sub>PEN</sub></b>	Refers to timing or voltage levels	

## 1.2 Acronyms

<b>SBC</b>	Single Bit per Cell
<b>FDI</b>	Flash Data Integrator
<b>CFI</b>	Common Flash Interface
<b>SCS</b>	Scalable Command Set
<b>CUI</b>	Command User Interface
<b>OTP</b>	One Time Programmable
<b>PLR</b>	Protection Lock Register
<b>PR</b>	Protection Register
<b>PRD</b>	Protection Register Data
<b>RFU</b>	Reserved for Future Use
<b>SR</b>	Status Register
<b>SRD</b>	Status Register Data
<b>WSM</b>	Write State Machine
<b>ECR</b>	Enhanced Configuration Register
<b>ECD</b>	Enhanced Configuration Register Data

## 1.3 Conventions

<b>h</b>	Hexadecimal Suffix
<b>K(noun)</b>	1,000
<b>M(noun)</b>	1,000,000
<b>Nibble</b>	4 bits
<b>Byte</b>	8 bits
<b>Word</b>	16 bits
<b>Kb</b>	1,024 bits
<b>KB</b>	1,024 bytes
<b>KW</b>	1,024 words
<b>Mb</b>	1,048,576 bits
<b>MB</b>	1,048,576 bytes
<b>MW</b>	1,048,576 words
<b>Kbit</b>	1,024 bits
<b>Mbit</b>	1,048,576 bits

<b>Brackets</b>	Square brackets ([ ]) will be used to designate group membership or to define a group of signals with similar function (i.e. A[21:1], SR[4,1] and D[15:0]).
<b>00FFh</b>	Denotes 16-bit hexadecimal numbers
<b>00FF 00FFh</b>	Denotes 32-bit hexadecimal numbers
<b>DQ[15:0]</b>	Data I/O signals

## 2.0 Functional Overview

The J3 65 nm SBC family contains high-density memory organized in any of the following configurations:

- 16-MB or 8-MW (128-Mbit), organized as one-hundred-twenty-eight 128-KB erase blocks.
- 8-MB or 4-MW (64-Mbit), organized as sixty-four 128-KB erase blocks.
- 4-MB or 2-MW (32-Mbit), organized as thirty-two 128-KB erase blocks.

These devices can be accessed as 8- or 16-bit words. See [Figure 1, “Memory Block Diagram for 32-, 64-, 128-Mbit” on page 11](#) for further details.

A 128-bit Protection Register has multiple uses, including unique flash device identification.

The J3 65 nm SBC device includes new security features that were not available on the (previous) 0.13µm versions of the J3 family. These new security features prevent altering of code through different protection schemes that can be implemented, based on user requirements.

The J3 65 nm SBC optimized architecture and interface dramatically increases read performance by supporting page-mode reads. This read mode is ideal for non-clock memory systems.

Its Common Flash Interface (CFI) permits software algorithms to be used for entire families of devices. This allows device-independent, JEDEC ID-independent, and forward- and backward-compatible software support for the specified flash device families. Flash vendors can standardize their existing interfaces for long-term compatibility.

The Scalable Command Set (SCS) allows a single, simple software driver in all host systems to work with all SCS-compliant flash memory devices, independent of system-level packaging (e.g., memory card, SIMM, or direct-to-board placement). Additionally, SCS provides the highest system/device data transfer rates and minimizes device and system-level implementation costs.

A Command User Interface (CUI) serves as the interface between the system processor and internal operation of the device. A valid command sequence written to the CUI initiates device automation. An internal Write State Machine (WSM) automatically executes the algorithms and timings necessary for block erase, program, and lock-bit configuration operations.

A block erase operation erases one of the device's 128-KB blocks typically within one second, independent of other blocks. Each block can be independently erased 100,000 times. Block erase suspend mode allows system software to suspend block erase to read or program data from any other block. Similarly, program suspend allows system software to suspend programming (byte/word program and write-to-buffer operations) to read data or execute code from any other block that is not being suspended.

Each device incorporates a Write Buffer of 256-Byte (x8 mode) or 256-Word (x16 mode) to allow optimum programming performance. By using the Write Buffer data is programmed more efficiently in buffer increments.

Memory Blocks are selectively and individually lockable in-system. Individual block locking uses block lock-bits to lock and unlock blocks. Block lock-bits gate block erase and program operations. Lock-bit configuration operations set and clear lock-bits (using the Set Block Lock-Bit and Clear Block Lock-Bits commands).

The Status Register indicates when the WSM's block erase, program, or lock-bit configuration operation completes.

The STS (status) output gives an additional indicator of WSM activity by providing both a hardware signal of status (versus software polling) and status masking (interrupt masking for background block erase, for example). Status indication using STS minimizes both CPU overhead and system power consumption. When configured in level mode (default mode), it acts as a RY/BY# signal. When low, STS indicates that the WSM is performing a block erase, program, or lock-bit configuration. STS-high indicates that the WSM is ready for a new command, block erase is suspended (and programming is inactive), program is suspended, or the device is in reset/power-down mode. Additionally, the configuration command allows the STS signal to be configured to pulse on completion of programming and/or block erases.

Three CE signals are used to enable and disable the device. A unique CE logic design (see [Table 17, "Chip Enable Truth Table for 32-, 64-, 128-Mb" on page 30](#)) reduces decoder logic typically required for multi-chip designs. External logic is not required when designing a single chip, a dual chip, or a 4-chip miniature card or SIMM module.

The BYTE# signal allows either x8 or x16 read/writes to the device:

- BYTE#-low enables 8-bit mode; address A0 selects between the low byte and high byte.
- BYTE#-high enables 16-bit operation; address A1 becomes the lowest order address and address A0 is not used (don't care).

[Figure 1, "Memory Block Diagram for 32-, 64-, 128-Mbit" on page 11](#) shows a device block diagram.

When the device is disabled (see [Table 17, "Chip Enable Truth Table for 32-, 64-, 128-Mb" on page 30](#)), with CEx at  $V_{IH}$  and RP# at  $V_{IH}$ , the standby mode is enabled. When RP# is at  $V_{IL}$ , a further power-down mode is enabled which minimizes power consumption and provides write protection during reset. A reset time ( $t_{PHQV}$ ) is required from RP# going high until data outputs are valid. Likewise, the device has a wake time ( $t_{PHWL}$ ) from RP#-high until writes to the CUI are recognized. With RP# at  $V_{IL}$ , the WSM is reset and the Status Register is cleared.

## 2.1 Block Diagram

Figure 1: Memory Block Diagram for 32-, 64-, 128-Mbit

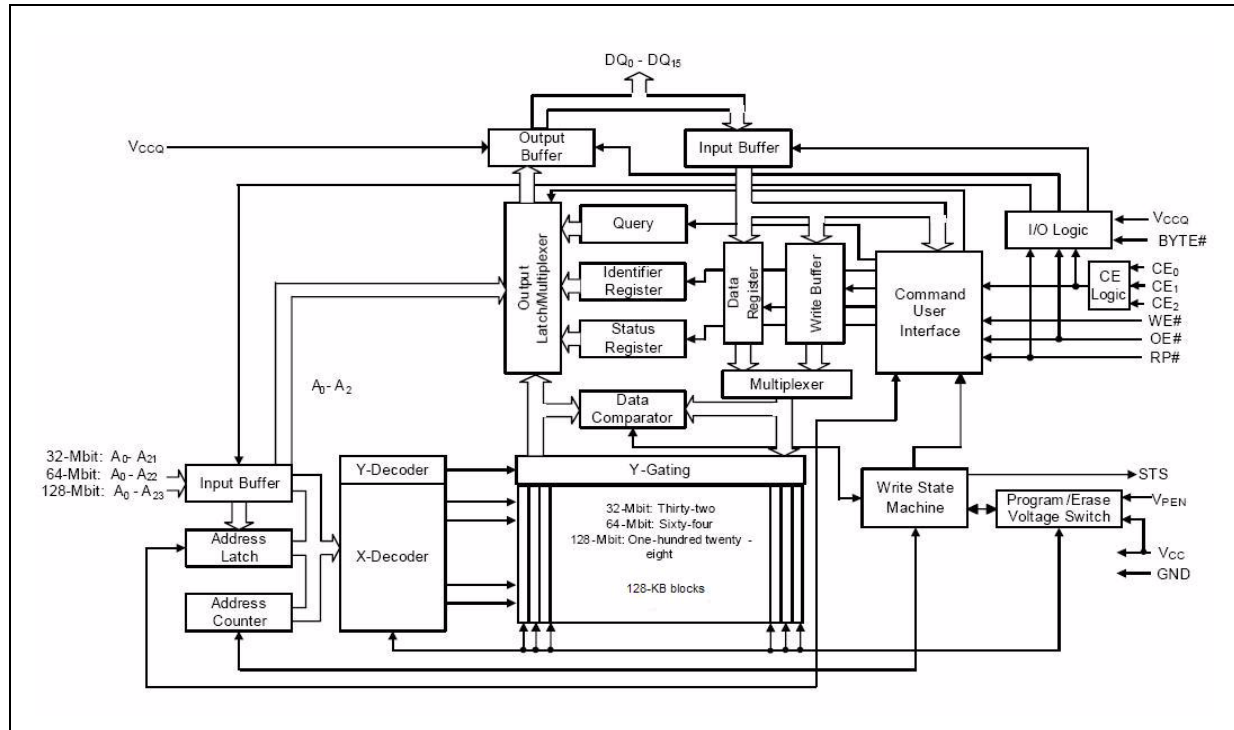

## 2.2 Memory Map

Figure 2: J3 65 nm SBC Memory Map

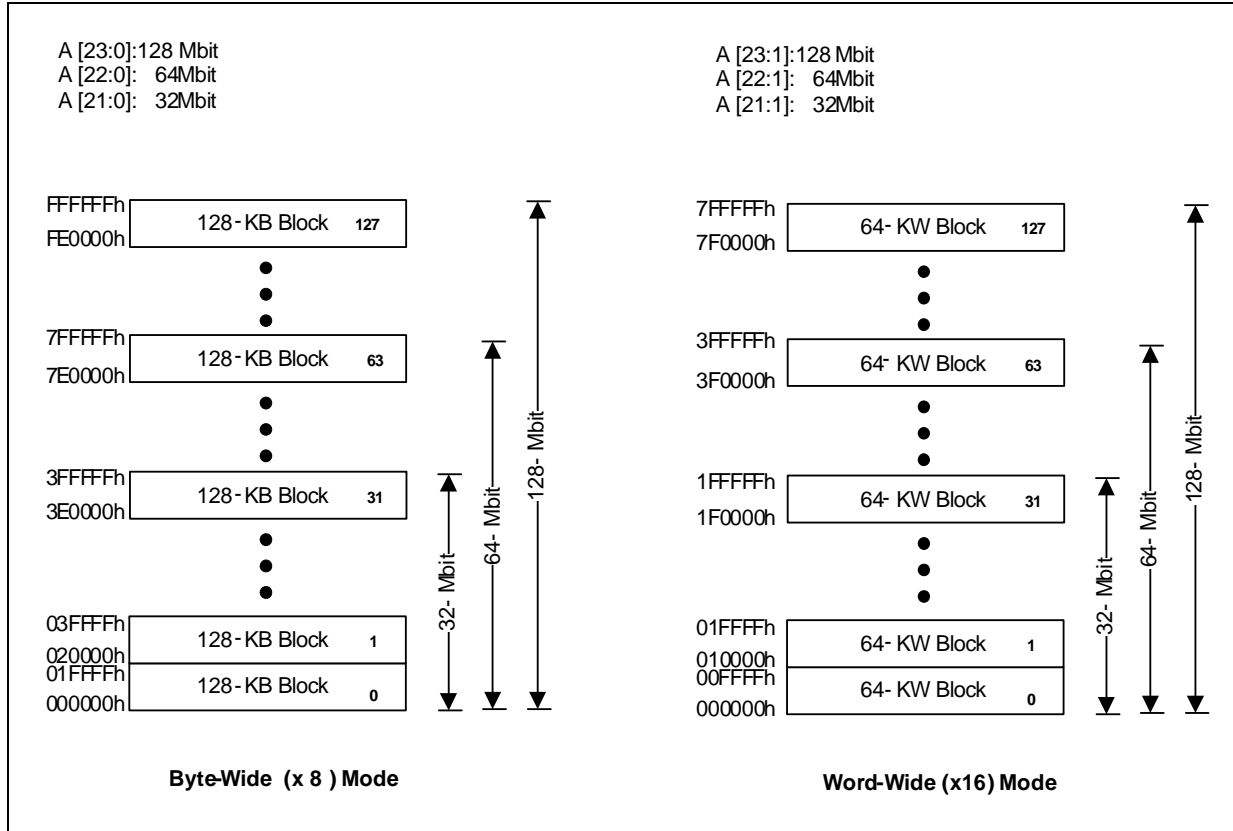

### 3.0 Package Information

#### 3.1 56-Lead TSOP Package for 32-, 64-, 128-Mbit

Figure 3: 56-Lead TSOP Package Mechanical

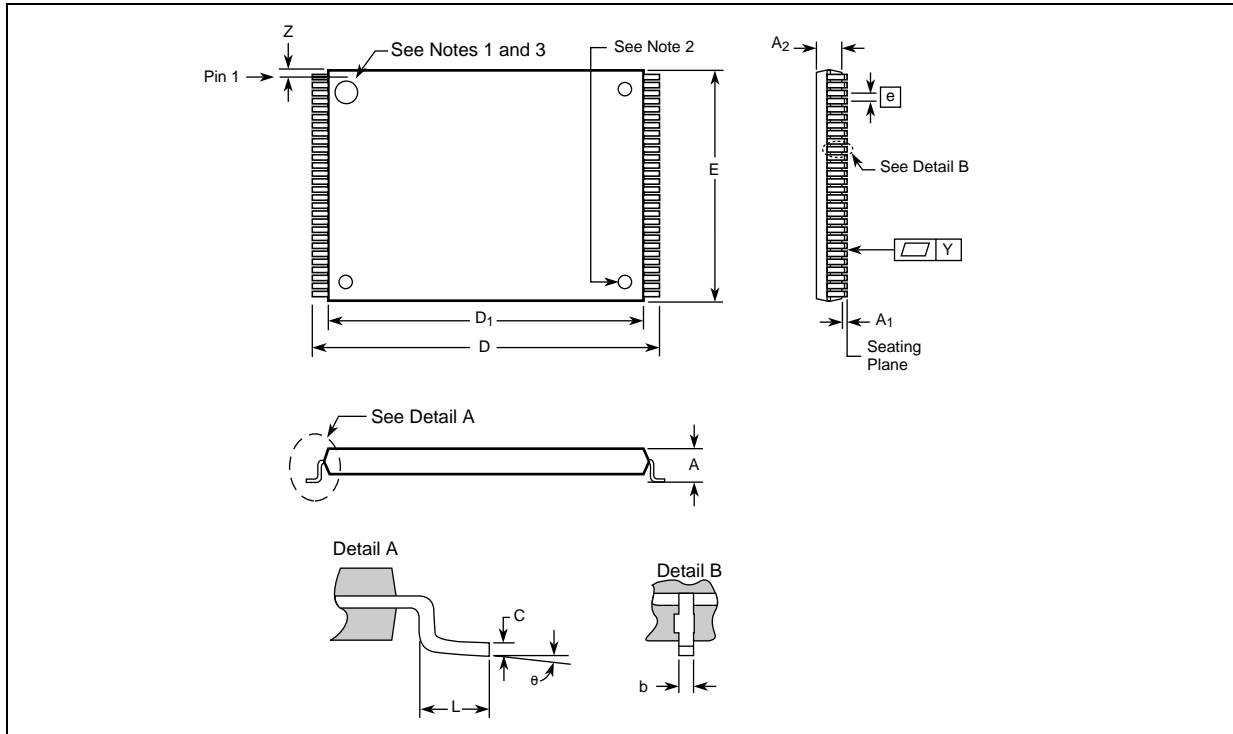

**Notes:**

1. One dimple on package denotes Pin 1.
2. If two dimples, then the larger dimple denotes Pin 1.
3. Pin 1 will always be in the upper left corner of the package, in reference to the product mark.

Table 1: 56-Lead TSOP Dimension Table

Parameter	Symbol	Millimeters			Inches		
		Min	Nom	Max	Min	Nom	Max
Package Height	A	—	—	1.200	—	—	0.047
Standoff	A <sub>1</sub>	0.050	—	—	0.002	—	—
Package Body Thickness	A <sub>2</sub>	0.965	0.995	1.025	0.038	0.039	0.040
Lead Width <sup>1</sup>	b	0.170	0.220	0.270	0.0067	0.0087	0.0106
Lead Thickness	c	0.100	0.150	0.200	0.004	0.006	0.008
Package Body Length	D <sub>1</sub>	18.200	18.400	18.600	0.717	0.724	0.732
Package Body Width	E	13.800	14.000	14.200	0.543	0.551	0.559
Lead Pitch	e	—	0.500	—	—	0.0197	—
Terminal Dimension	D	19.800	20.00	20.200	0.780	0.787	0.795
Lead Tip Length	L	0.500	0.600	0.700	0.020	0.024	0.028

**Table 1: 56-Lead TSOP Dimension Table**

Parameter	Symbol	Millimeters			Inches		
		Min	Nom	Max	Min	Nom	Max
Lead Count	N	—	56	—	—	56	—
Lead Tip Angle	$\theta$	0°	3°	5°	0°	3°	5°
Seating Plane Coplanarity	Y	—	—	0.100	—	—	0.004
Lead to Package Offset	Z	0.150	0.250	0.350	0.006	0.010	0.014

1. For legacy lead width, 0.15mm (Typ), 0.10mm (Min), 0.20mm (Max).

### 3.2 64-Ball Easy BGA Package for 32-, 64-, 128-Mbit

**Figure 4: 64-Ball Easy BGA Mechanical Specifications**

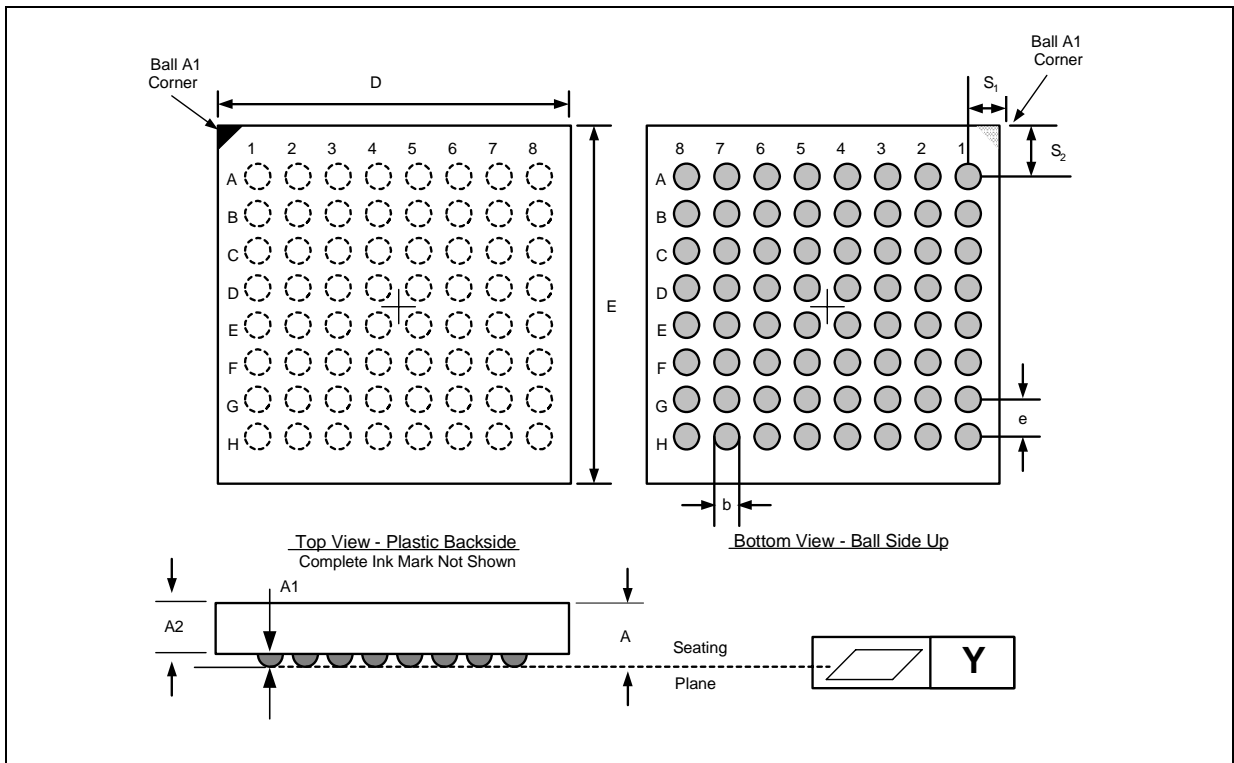

**Table 2: Easy BGA Package Dimensions Table (Sheet 1 of 2)**

Parameter	Symbol	Millimeters			Inches		
		Min	Nom	Max	Min	Nom	Max
Package Height	A	—	—	1.200	—	—	0.0472
Ball Height	A1	0.250	—	—	0.0098	—	—
Package Body Thickness	A2	—	0.780	—	—	0.0307	—
Ball (Lead) Width	b	0.310	0.410	0.510	0.012	0.016	0.020

**Table 2: Easy BGA Package Dimensions Table (Sheet 2 of 2)**

Parameter	Symbol	Millimeters			Inches		
		Min	Nom	Max	Min	Nom	Max
Package Body Width	D	9.900	10.000	10.100	0.3898	0.3937	0.3976
Package Body Length	E	12.900	13.000	13.100	0.5079	0.5118	0.5157
Pitch	e	—	1.000	—	—	0.0394	—
Ball (Lead) Count	N	—	64	—	—	64	—
Seating Plane Coplanarity	Y	—	—	0.100	—	—	0.0039
Corner to Ball A1 Distance Along D	S1	1.400	1.500	1.600	0.0551	0.0591	0.0630
Corner to Ball A1 Distance Along E	S2	2.900	3.000	3.100	0.1142	0.1181	0.1220

## 4.0 Ballouts/Pinouts and Signal Descriptions

J3 65 nm SBC is available in two package types. All densities of the J3 65 nm SBC devices are supported on both 64-ball Easy BGA and 56-lead Thin Small Outline Package (TSOP) packages. The figures below show the ballouts/Pinouts.

### 4.1 Easy BGA Ballout for 32-, 64-, 128-Mbit

Figure 5: Easy BGA Ballout (32/64/128 Mbit)

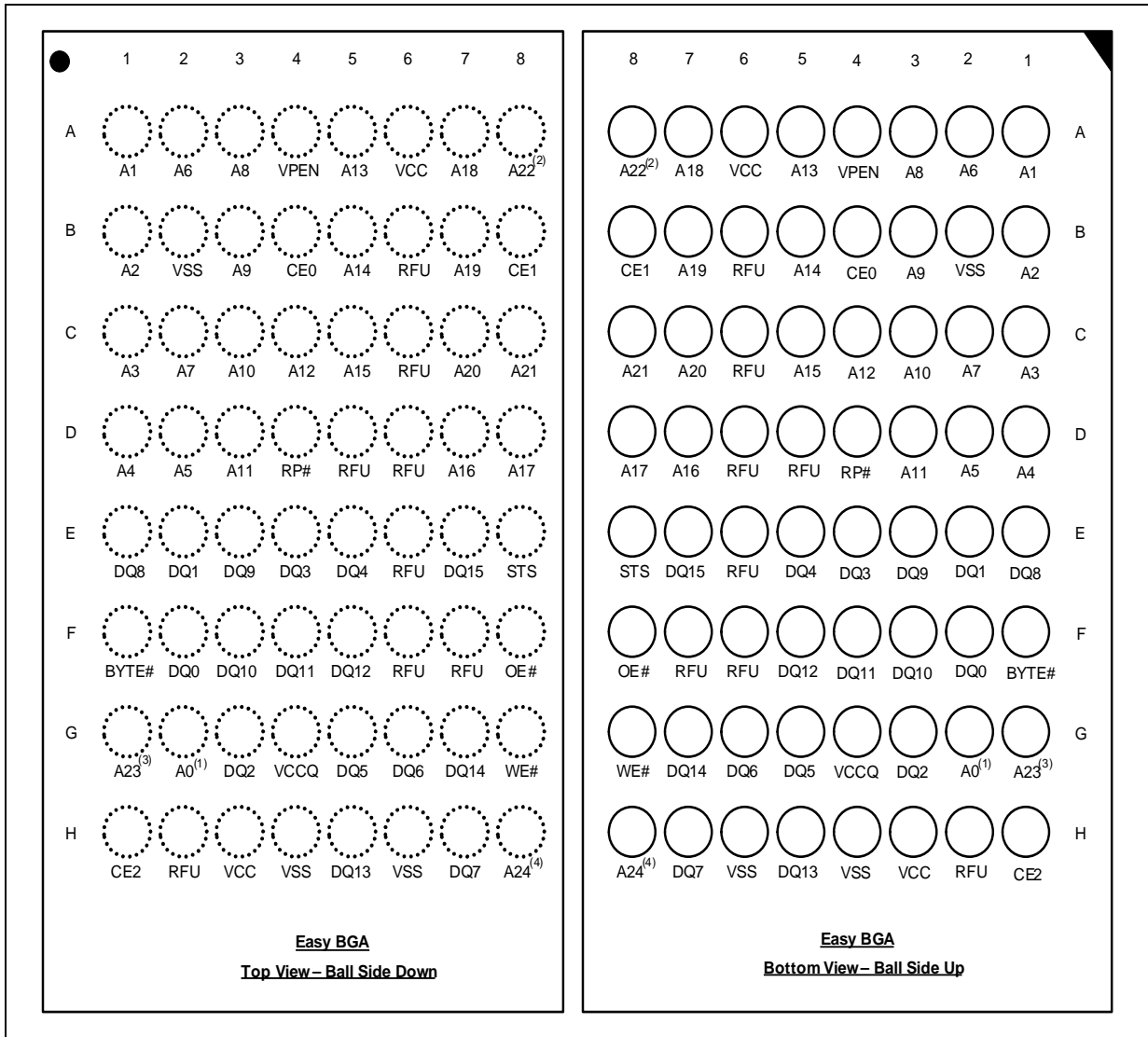

**Notes:**

1. A0 is the least significant address bit.
2. A22 is valid for 64-Mbit density and above. On 32-Mbit, it is a no-connect (NC).
3. A23 is valid for 128-Mbit density. On 32- and 64-Mbit, it is a no-connect (NC).
4. A24 is a no connect (NC) on 128-, 64-, 32- Mbit, reserved for 256-Mbit.

## 4.2 56-Lead TSOP Package Pinout for 32-, 64-, 128-Mbit

Figure 6: 56-Lead TSOP Package Pinout (32/64/128 Mbit)

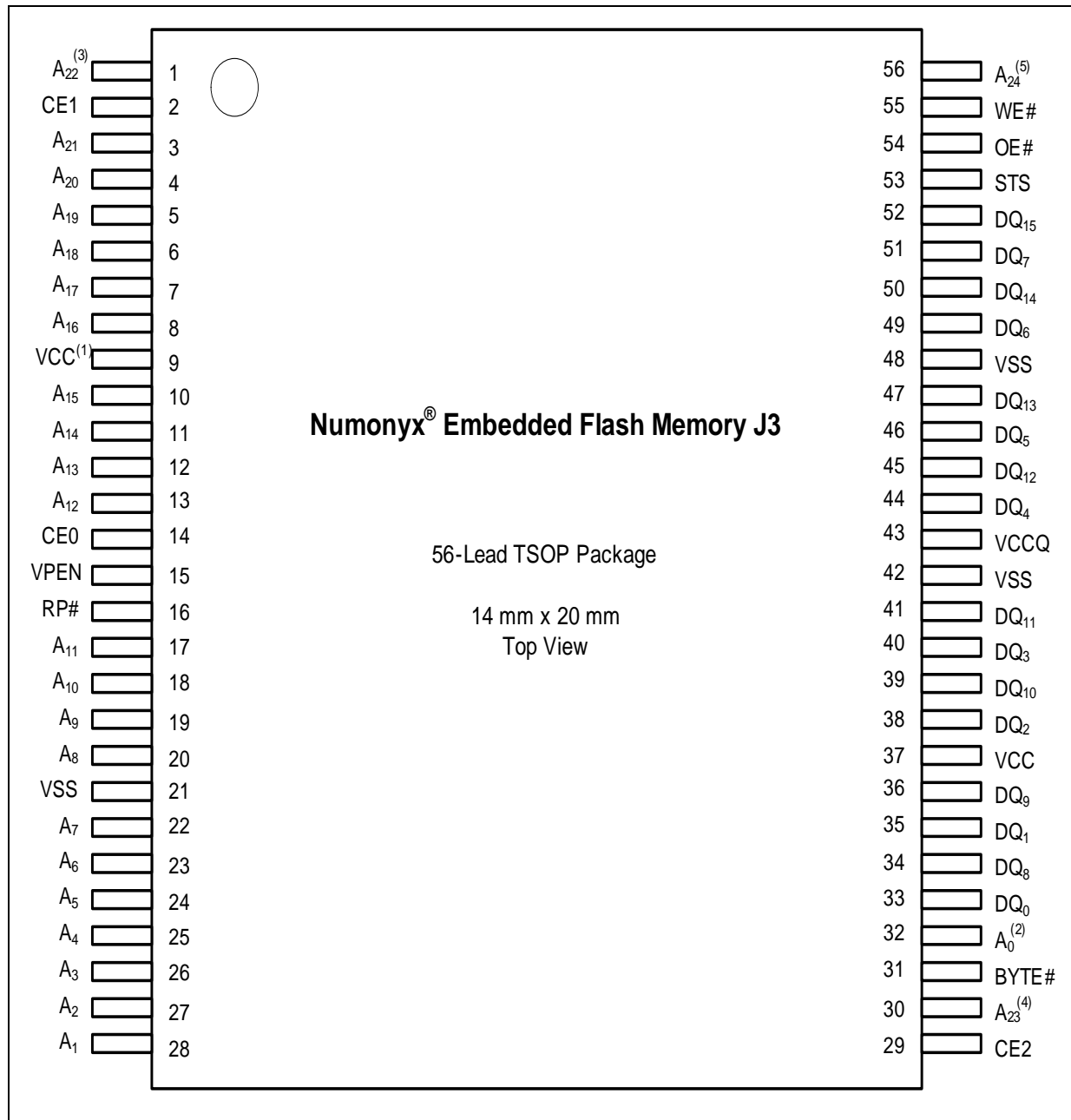

**Notes:**

1. No internal connection for pin 9; it may be driven or floated. For legacy designs, the pin can be tied to V<sub>CC</sub>.
2. A<sub>0</sub> is the least significant address bit.
3. A<sub>22</sub> is valid for 64-Mbit density and above. On 32-Mbit, it is a no-connect (NC).
4. A<sub>23</sub> is valid for 128-Mbit density. On 32- and 64-Mbit, it is a no-connect (NC).
5. A<sub>24</sub> is a no connect (NC) on 128-, 64-, 32- Mbit, reserved for 256-Mbit.

## 4.3 Signal Descriptions

Table 3 lists the active signals used on J3 65 nm SBC and provides a description of each.

**Table 3: Signal Descriptions for J3 65 nm SBC**

Symbol	Type	Name and Function
A0	Input	<b>BYTE-SELECT ADDRESS:</b> Selects between high and low byte when the device is in x8 mode. This address is latched during a x8 program cycle. Not used in x16 mode (i.e., the A0 input buffer is turned off when BYTE# is high).
A[MAX:1]	Input	<b>ADDRESS INPUTS:</b> Inputs for addresses during read and program operations. Addresses are internally latched during a program cycle: 32-Mbit — A[21:1] 64-Mbit — A[22:1] 128-Mbit — A[23:1]
DQ[7:0]	Input/Output	<b>LOW-BYTE DATA BUS:</b> Inputs data during buffer writes and programming, and inputs commands during CUI writes. Outputs array, CF1, identifier, or status data in the appropriate read mode. Data is internally latched during write operations.
DQ[15:8]	Input/Output	<b>HIGH-BYTE DATA BUS:</b> Inputs data during x16 buffer writes and programming operations. Outputs array, CF1, or identifier data in the appropriate read mode; not used for Status Register reads. Data is internally latched during write operations in x16 mode. D[15:8] float in x8 mode.
CE[2:0]	Input	<b>CHIP ENABLE:</b> Activates the 32-, 64-, 128-Mbit devices' control logic, input buffers, decoders, and sense amplifiers. When the device is de-selected (see Table 17, "Chip Enable Truth Table for 32-, 64-, 128-Mb" on page 30), power reduces to standby levels. All timing specifications are the same for these three signals. Device selection occurs with the first edge of CE0, CE1, or CE2 that enables the device. Device deselection occurs with the first edge of CE0, CE1, or CE2 that disables the device (see Table 17, "Chip Enable Truth Table for 32-, 64-, 128-Mb" on page 30).
RP#	Input	<b>RESET:</b> RP#-low resets internal automation and puts the device in power-down mode. RP#-high enables normal operation. Exit from reset sets the device to read array mode. When driven low, RP# inhibits write operations which provides data protection during power transitions.
OE#	Input	<b>OUTPUT ENABLE:</b> Activates the device's outputs through the data buffers during a read cycle. OE# is active low.
WE#	Input	<b>WRITE ENABLE:</b> Controls writes to the CUI, the Write Buffer, and array blocks. WE# is active low. Addresses and data are latched on the rising edge of WE#.
STS	Open Drain Output	<b>STATUS:</b> Indicates the status of the internal state machine. When configured in level mode (default), it acts as a RY/BY# signal. When configured in one of its pulse modes, it can pulse to indicate program and/or erase completion. For alternate configurations of the Status signal, see the Configurations command and Section 9.7, "Status Signal" on page 41. STS is to be tied to VCCQ with a pull-up resistor.
BYTE#	Input	<b>BYTE ENABLE:</b> BYTE#-low places the device in x8 mode; data is input or output on D[7:0], while D[15:8] is placed in High-Z. Address A0 selects between the high and low byte. BYTE#-high places the device in x16 mode, and turns off the A0 input buffer, the address A1 becomes the lowest-order address bit.
VPEN	Input	<b>ERASE / PROGRAM / BLOCK LOCK ENABLE:</b> For erasing array blocks, programming data, or configuring lock-bits. With $V_{PEN} \leq V_{PENLK}$ , memory contents cannot be altered.
VCC	Power	<b>CORE Power Supply:</b> Core (logic) source voltage. Writes to the flash array are inhibited when $V_{CC} \leq V_{Lko}$ . Caution: Device operation at invalid Vcc voltages should not be attempted.
VCCQ	Power	<b>I/O Power Supply:</b> Power supply for Input/Output buffers. This ball can be tied directly to VCC.
VSS	Supply	<b>GROUND:</b> Ground reference for device logic voltages. Connect to system ground.
NC	—	<b>No Connect:</b> Lead is not internally connected; it may be driven or floated.
RFU	—	<b>Reserved for Future Use:</b> Balls designated as RFU are reserved by Numonyx for future device functionality and enhancement.

## 5.0 Maximum Ratings and Operating Conditions

### 5.1 Absolute Maximum Ratings

**Warning:** Stressing the device beyond the “Absolute Maximum Ratings” may cause permanent damage. These are stress ratings only.

NOTICE: This document contains information available at the time of its release. The specifications are subject to change without notice. Verify with your local Numonyx sales office that you have the latest datasheet before finalizing a design.

**Table 4: Absolute Maximum Ratings**

Parameter	Min	Max	Unit	Notes
Temperature under Bias Expanded ( $T_A$ , Ambient)	-40	+85	°C	—
Storage Temperature	-65	+125	°C	—
VCC Voltage	-2.0	+5.6	V	2
VCCQ Voltage	-2.0	+5.6	V	2
Voltage on any input/output signal (except VCC, VCCQ)	-2.0	$V_{CCQ} (max) + 2.0$	V	1
$I_{SH}$ Output Short Circuit Current	—	100	mA	3

**Notes:**

1. Voltage is referenced to  $V_{SS}$ . During infrequent non-periodic transitions, the voltage potential between  $V_{SS}$  and input/output pins may undershoot to -2.0 V for periods < 20 ns or overshoot to  $V_{CCQ} (max) + 2.0$  V for periods < 20 ns.
2. During infrequent non-periodic transitions, the voltage potential between  $V_{CC}$  and the supplies may undershoot to -2.0 V for periods < 20 ns or  $V_{SUPPLY} (max) + 2.0$  V for periods < 20 ns.
3. Output shorted for less than one second. No more than one output pin/ball can be shorted at a time.

### 5.2 Operating Conditions

**Warning:** Operations beyond the “Operating Conditions” is not recommended and extended exposure beyond the “Operating Conditions” may affect device reliability.

**Table 5: Temperature and  $V_{CC}$  Operating Condition**

Symbol	Parameter	Min	Max	Unit	Test Condition
$T_A$	Operating Temperature	-40.0	+85	°C	Ambient Temperature
$V_{CC}$	VCC Supply Voltage	2.70	3.6	V	—
$V_{CCQ}$	VCCQ Supply Voltage	2.70	3.6	V	—

### 5.3 Power-Up/Down

This section provides an overview of system level considerations with regards to the flash device. It includes a brief description of power-up/down sequence and decoupling design considerations.

#### 5.3.1 Power-Up/Down Sequence

To prevent conditions that could result in spurious program or erase operations, the power-up/power-down sequence shown in [Table 6](#) is recommended. For DC voltage characteristics refer to [Table 8](#). Note that each power supply must reach its minimum voltage range before applying/removing the next supply voltage.

**Table 6: Power-Up/Down Sequence**

Power Supply Voltage	Power-Up Sequence				Power-Down Sequence			
V <sub>CC(min)</sub>	1st	1st	1st <sup>(1)</sup>	Sequencing not required <sup>(1)</sup>	3rd	2nd	2nd <sup>(1)</sup>	Sequencing not required <sup>(1)</sup>
V <sub>CCQ(min)</sub>	2nd	2nd <sup>(1)</sup>			2nd	1st <sup>(1)</sup>		
V <sub>PEN(min)</sub>	3rd		2nd		1st		1st	

**Note:**

1. Power supplies connected or sequenced together.

Device inputs must not be driven until all supply voltages reach their minimum range. RP# should be low during power transitions.

### 5.3.2 Power Supply Decoupling

When the device is enabled, many internal conditions change. Circuits are energized, charge pumps are switched on, and internal voltage nodes are ramped. All of this internal activities produce transient signals. The magnitude of the transient signals depends on the device and system loading. To minimize the effect of these transient signals, a 0.1 μF ceramic capacitor is required across each VCC/VSS and VCCQ signal. Capacitors should be placed as close as possible to device connections.

Additionally, for every eight flash devices, a 4.7 μF electrolytic capacitor should be placed between VCC and VSS at the power supply connection. This 4.7 μF capacitor should help overcome voltage slumps caused by PCB trace inductance.

### 5.4 Reset

By holding the flash device in reset during power-up and power-down transitions, invalid bus conditions may be masked. The flash device enters reset mode when RP# is driven low. In reset, internal flash circuitry is disabled and outputs are placed in a high-impedance state. After return from reset, a certain amount of time is required before the flash device is able to perform normal operations. After return from reset, the flash device defaults to asynchronous page mode. If RP# is driven low during a program or erase operation, the program or erase operation will be aborted and the memory contents at the aborted block or address are no longer valid. See [Figure 12, “AC Waveform for Reset Operation” on page 28](#) for detailed information regarding reset timings.

## 6.0 Electrical Characteristics

### 6.1 DC Current Specifications

Table 7: DC Current Characteristics

$V_{CCQ}$		2.7 - 3.6V			Test Conditions	Notes
$V_{CC}$		2.7 - 3.6V				
Symbol	Parameter	Typ	Max	Unit		
$I_{LI}$	Input and $V_{PEN}$ Load Current	—	$\pm 1$	$\mu A$	$V_{CC} = V_{CC} \text{ Max}; V_{CCQ} = V_{CCQ} \text{ Max}$ $V_{IN} = V_{CCQ} \text{ or } V_{SS}$	1
$I_{LO}$	Output Leakage Current	—	$\pm 10$	$\mu A$	$V_{CC} = V_{CC} \text{ Max}; V_{CCQ} = V_{CCQ} \text{ Max}$ $V_{IN} = V_{CCQ} \text{ or } V_{SS}$	1
$I_{CCS}$	$V_{CC}$ Standby Current	50	120	$\mu A$	CMOS Inputs, $V_{CC} = V_{CC} \text{ Max}; V_{CCQ} = V_{CCQ} \text{ Max}$ Device is disabled (see Table 17, "Chip Enable Truth Table for 32-, 64-, 128-Mb" on page 30), $RP\# = V_{CCQ} \pm 0.2 \text{ V}$	1,2,3
		0.71	2	mA	TTL Inputs, $V_{CC} = V_{CC} \text{ Max},$ $V_{CCQ} = V_{CCQ} \text{ Max}$ Device is disabled (see Table 17, "Chip Enable Truth Table for 32-, 64-, 128-Mb" on page 30), $RP\# = V_{IH}$	
$I_{CCD}$	$V_{CC}$ Power-Down Current	50	120	$\mu A$	$RP\# = V_{SS} \pm 0.2 \text{ V}, I_{OUT} \text{ (STS)} = 0 \text{ mA}$	—
$I_{CCR}$	8-Word Page	15	20	mA	CMOS Inputs, $V_{CC} = V_{CC} \text{ Max}, V_{CCQ} = V_{CCQ} \text{ Max}$ using standard 8 word page mode reads. Device is enabled (see Table 17, "Chip Enable Truth Table for 32-, 64-, 128-Mb" on page 30) $f = 5 \text{ MHz}, I_{OUT} = 0 \text{ mA}$	1,3
		30	54	mA	CMOS Inputs, $V_{CC} = V_{CC} \text{ Max}, V_{CCQ} = V_{CCQ} \text{ Max}$ using standard 8 word page mode reads. Device is enabled (see Table 17, "Chip Enable Truth Table for 32-, 64-, 128-Mb" on page 30) $f = 33 \text{ MHz}, I_{OUT} = 0 \text{ mA}$	
$I_{CCW}$	$V_{CC}$ Program or Set Lock-Bit Current	35	60	mA	CMOS Inputs, $V_{PEN} = V_{CC}$	1,4
		40	70	mA	TTL Inputs, $V_{PEN} = V_{CC}$	
$I_{CCE}$ $I_{CCBC}$	$V_{CC}$ Block Erase or $V_{CC}$ Blank Check or Clear Block Lock-Bits Current	35	70	mA	CMOS Inputs, $V_{PEN} = V_{CC}$	1,4
		40	80	mA	TTL Inputs, $V_{PEN} = V_{CC}$	
$I_{CCWS}$ $I_{CCES}$	$V_{CC}$ Program Suspend or Block Erase Suspend Current	—	10	mA	Device is enabled (see Table 17, "Chip Enable Truth Table for 32-, 64-, 128-Mb" on page 30)	1,5

**Notes:**

- All currents are in RMS unless otherwise noted. These currents are valid for all product versions (packages and speeds). Contact Numonyx or your local sales office for information about typical specifications.
- Includes STS.
- CMOS inputs are either  $V_{CC} \pm 0.2 \text{ V}$  or  $V_{SS} \pm 0.2 \text{ V}$ . TTL inputs are either  $V_{IL}$  or  $V_{IH}$ .
- Sampled, not 100% tested.
- $I_{CCWS}$  and  $I_{CCES}$  are specified with the device selected. If the device is read or written while in erase suspend mode, the device's current draw is  $I_{CCR}$  and  $I_{CCWS}$ .

## 6.2 DC Voltage specifications

Table 8: DC Voltage Characteristics

$V_{CCQ}$		2.7 - 3.6 V			Test Conditions	Notes
$V_{CC}$		2.7 - 3.6 V				
Symbol	Parameter	Min	Max	Unit		
$V_{IL}$	Input Low Voltage	-0.5	0.8	V	—	2, 5, 6
$V_{IH}$	Input High Voltage	2.0	$V_{CCQ} + 0.5$	V	—	2, 5, 6
$V_{OL}$	Output Low Voltage	—	0.4	V	$V_{CC} = V_{CCMin}$ $V_{CCQ} = V_{CCQ Min}$ $I_{OL} = 2 \text{ mA}$	1, 2
		—	0.2	V	$V_{CC} = V_{CCMin}$ $V_{CCQ} = V_{CCQ Min}$ $I_{OL} = 100 \mu\text{A}$	
$V_{OH}$	Output High Voltage	$0.85 \times V_{CCQ}$	—	V	$V_{CC} = V_{CCMin}$ $V_{CCQ} = V_{CCQ Min}$ $I_{OH} = -2.5 \text{ mA}$	1, 2
		$V_{CCQ} - 0.2$	—	V	$V_{CC} = V_{CCMin}$ $V_{CCQ} = V_{CCQ Min}$ $I_{OH} = -100 \mu\text{A}$	
$V_{PENLK}$	$V_{PEN}$ Lockout during Program, Erase and Lock-Bit Operations	—	2.2	V	—	2, 3
$V_{PENH}$	$V_{PEN}$ during Block Erase, Program, or Lock-Bit Operations	2.7	3.6	V	—	3
$V_{LKO}$	$V_{CC}$ Lockout Voltage	—	2.0	V	—	4

**Notes:**

- Includes STS.
- Sampled, not 100% tested.
- Block erases, programming, and lock-bit configurations are inhibited when  $V_{PEN} \leq V_{PENLK}$ , and not guaranteed in the range between  $V_{PENLK}$  (max) and  $V_{PENH}$  (min), and above  $V_{PENH}$  (max).
- Block erases, programming, and lock-bit configurations are inhibited when  $V_{CC} \leq V_{LKO}$ , and not guaranteed in the range between  $V_{LKO}$  and  $V_{CC}$  (min), and above  $V_{CC}$  (max).
- Includes all operational modes of the device.
- Input/Output signals can undershoot to -1.0V referenced to  $V_{SS}$  and can overshoot to  $V_{CCQ} + 1.0V$  for duration of 2ns or less, the  $V_{CCQ}$  valid range is referenced to  $V_{SS}$ .

## 6.3 Capacitance

Table 9: Capacitance

Symbol	Parameter <sup>1</sup>	Type	Max	Unit	Condition <sup>2</sup>
$C_{IN}$	Input Capacitance	6	7	pF	$V_{IN} = 0.0 \text{ V}$
$C_{OUT}$	Output Capacitance	4	5	pF	$V_{OUT} = 0.0 \text{ V}$

**Notes:**

- Sampled, not 100% tested.
- $T_A = -40 \text{ }^\circ\text{C}$  to  $+85 \text{ }^\circ\text{C}$ ,  $V_{CC} = V_{CCQ} = 0$  to 3.6 V.

## 7.0 AC Characteristics

Timing symbols used in the timing diagrams within this document conform to the following convention.

**Figure 7: Timing Signal Naming Convention**

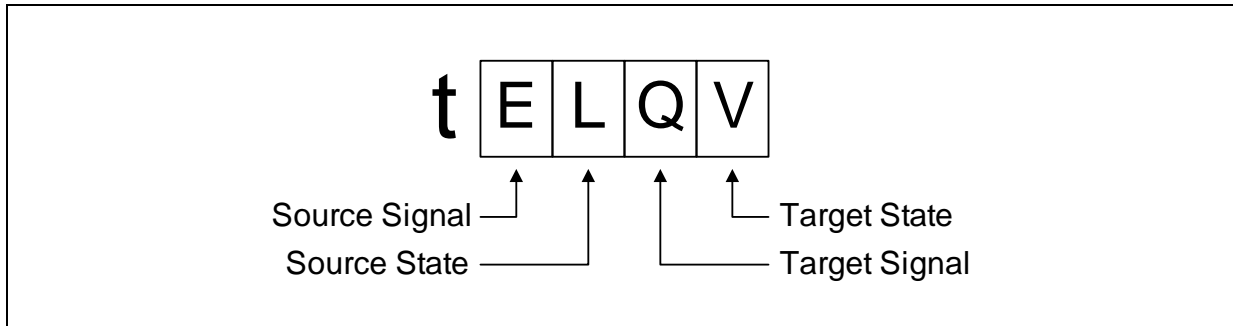

**Table 10: Timing Signal Name Decoder**

Signal	Code	State	Code
Address	A	High	H
Data - Read	Q	Low	L
Data - Write	D	High-Z	Z
Chip Enable (CE)	E	Low-Z	X
Output Enable (OE#)	G	Valid	V
Write Enable (WE#)	W	Invalid	I
Status (STS)	R		
Reset (RP#)	P		
Byte Enable (BYTE#)	F		
Erase/Program/Block Lock Enable (V <sub>PEN</sub> )	V		

**Note:** Exceptions to this convention include  $t_{ACC}$  and  $t_{APA}$ .  $t_{ACC}$  is a generic timing symbol that refers to the aggregate initial-access delay as determined by  $t_{AVQV}$ ,  $t_{ELQV}$ , and  $t_{GLQV}$  (whichever is satisfied last) of the flash device.  $t_{APA}$  is specified in the flash device's data sheet, and is the address-to-data delay for subsequent page-mode reads.

## 7.1 Read Specifications

Table 11: Read Operations

Asynchronous Specifications $V_{CC} = 2.7\text{ V} - 3.6\text{ V}^{(3)}$ and $V_{CCQ} = 2.7\text{ V} - 3.6\text{ V}^{(3)}$							
#	Sym	Parameter	Density	Min	Max	Unit	Notes
R1	$t_{AVAV}$	Read/Write Cycle Time	All	75	—	ns	1,2
R2	$t_{AVQV}$	Address to Output Delay		—	75	ns	1,2
R3	$t_{ELOV}$	CE <sub>X</sub> to Output Delay		—	75	ns	1,2
R4	$t_{GLOV}$	OE# to Non-Array Output Delay		—	25	ns	1,2,4
R5	$t_{PHQV}$	RP# High to Output Delay	32 Mbit	—	150	ns	1,2
			64 Mbit	—	180		1,2
			128 Mbit	—	210		1,2
R6	$t_{ELOX}$	CE <sub>X</sub> to Output in Low Z	All	0	—	ns	1,2,5
R7	$t_{GLOX}$	OE# to Output in Low Z		0	—	ns	1,2,5
R8	$t_{EHQZ}$	CE <sub>X</sub> High to Output in High Z		—	25	ns	1,2,5
R9	$t_{GHQZ}$	OE# High to Output in High Z		—	15	ns	1,2,5
R10	$t_{OH}$	Output Hold from Address, CE <sub>X</sub> , or OE# Change, Whichever Occurs First		0	—	ns	1,2,5
R11	$t_{ELFL}/t_{ELFH}$	CE <sub>X</sub> Low to BYTE# High or Low		—	10	ns	1,2,5
R12	$t_{FLOV}/t_{FHOV}$	BYTE# to Output Delay		—	1	µs	1,2
R13	$t_{FLOZ}$	BYTE# to Output in High Z		—	1	µs	1,2,5
R14	$t_{EHEL}$	CE <sub>X</sub> High to CE <sub>X</sub> Low		0	—	ns	1,2,5
R15	$t_{APA}$	Page Address Access Time		—	25	ns	5, 6
R16	$t_{GLOV}$	OE# to Array Output Delay		—	25	ns	1,2,4

**Notes:**

1. CE<sub>X</sub> low is defined as the combination of pins CE0, CE1 and CE2 that enable the device. CE<sub>X</sub> high is defined as the combination of pins CE0, CE1, and CE2 that disable the device (see [Table 17, "Chip Enable Truth Table for 32-, 64-, 128-Mb" on page 30](#)).
2. See AC Input/Output Reference Waveforms for the maximum allowable input slew rate.
3. OE# may be delayed up to  $t_{ELOV} - t_{GLOV}$  after the falling edge of CE<sub>X</sub> (see note 1 and [Table 17, "Chip Enable Truth Table for 32-, 64-, 128-Mb" on page 30](#)) without impact on  $t_{ELOV}$ .
4. See [Figure 13, "AC Input/Output Reference Waveform" on page 29](#) and [Figure 14, "Transient Equivalent Testing Load Circuit" on page 29](#) for testing characteristics.
5. Sampled, not 100% tested.
6. For devices configured to standard word/byte read mode, R15 ( $t_{APA}$ ) will equal R2 ( $t_{AVQV}$ ).

Figure 8: Single-Word Asynchronous Read Waveform

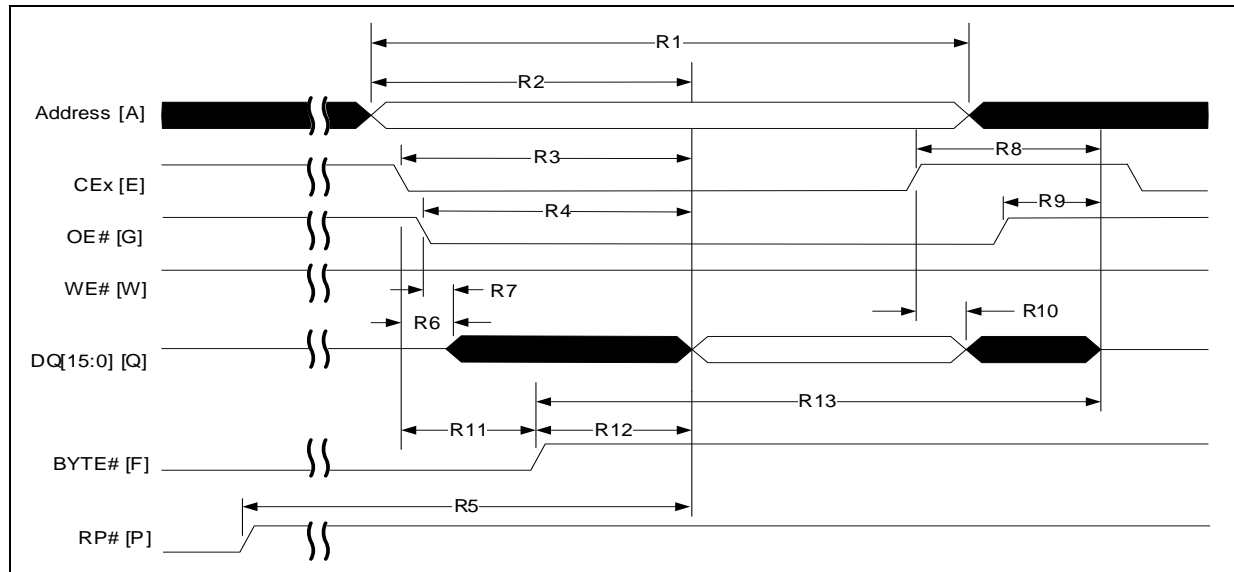

**Notes:**

1. CE<sub>x</sub> low is defined as the combination of pins CE0, CE1, and CE2 that enable the device. CE<sub>x</sub> high is defined as the combination of pins CE0, CE1, and CE2 that disable the device (see [Table 17, "Chip Enable Truth Table for 32-, 64-, 128-Mb" on page 30](#)).
2. When reading the flash array a faster t<sub>GLQV</sub> (R16) applies. For non-array reads, R4 applies (i.e., Status Register reads, query reads, or device identifier reads).

Figure 9: 8-Word Asynchronous Page Mode Read

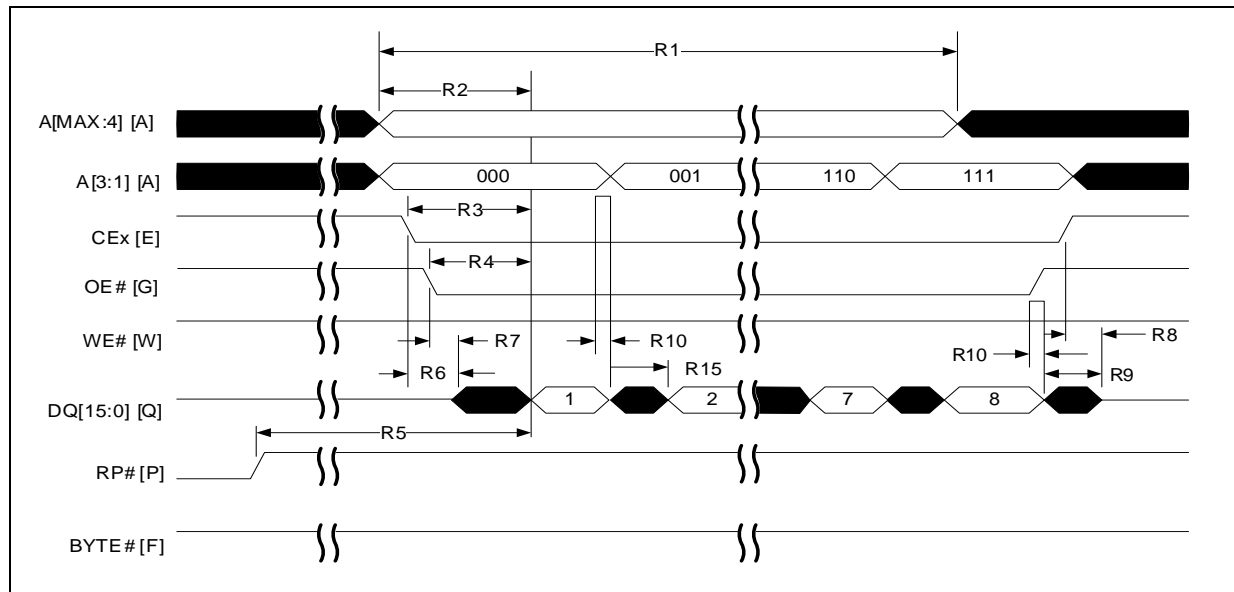

**Notes:**

1. CE<sub>x</sub> low is defined as the combination of pins CE0, CE1, and CE2 that enable the device. CE<sub>x</sub> high is defined as the combination of pins CE0, CE1, and CE2 that disable the device (see [Table 17, "Chip Enable Truth Table for 32-, 64-, 128-Mb" on page 30](#)).
2. In this diagram, BYTE# is asserted high.

**Table 12: Write Operations**

#	Symbol	Parameter	Density	Valid for All Speeds		Unit	Notes
				Min	Max		
W1	$t_{PHWL}$ ( $t_{PHEL}$ )	RP# High Recovery to WE# (CE <sub>X</sub> ) Going Low	32 Mbit	150	—	ns	1,2,3,4
			64 Mbit	180	—		
			128 Mbit	210	—		
W2	$t_{ELWL}$ ( $t_{WLEL}$ )	CE <sub>X</sub> (WE#) Low to WE# (CE <sub>X</sub> ) Going Low	All	0	—		1,2,3,5
W3	$t_{WP}$	Write Pulse Width		60	—		1,2,3,5
W4	$t_{DVWH}$ ( $t_{DVEH}$ )	Data Setup to WE# (CE <sub>X</sub> ) Going High		50	—		1,2,3,6
W5	$t_{AVWH}$ ( $t_{AVEH}$ )	Address Setup to WE# (CE <sub>X</sub> ) Going High		55	—		1,2,3,6
W6	$t_{WHEH}$ ( $t_{EHWH}$ )	CE <sub>X</sub> (WE#) Hold from WE# (CE <sub>X</sub> ) High		0	—		1,2,3
W7	$t_{WHDH}$ ( $t_{EHDH}$ )	Data Hold from WE# (CE <sub>X</sub> ) High		0	—		1,2,3
W8	$t_{WHAX}$ ( $t_{EHAX}$ )	Address Hold from WE# (CE <sub>X</sub> ) High		0	—		1,2,3
W9	$t_{WPH}$	Write Pulse Width High		30	—		1,2,3,7
W11	$t_{VPWH}$ ( $t_{VPEH}$ )	V <sub>PEN</sub> Setup to WE# (CE <sub>X</sub> ) Going High		0	—		1,2,3,4
W12	$t_{WHGL}$ ( $t_{EHGL}$ )	Write Recovery before Read		35	—		1,2,3,8
W13	$t_{WHRL}$ ( $t_{EHLR}$ )	WE# (CE <sub>X</sub> ) High to STS Going Low		—	500		1,2,3,9
W15	$t_{QVVL}$	V <sub>PEN</sub> Hold from Valid SRD, STS Going High		0	—		1,2,3,4,9,10

**Notes:**

- CE<sub>X</sub> low is defined as the combination of pins CE0, CE1, and CE2 that enable the device. CE<sub>X</sub> high is defined as the combination of pins CE0, CE1, and CE2 that disable the device (see [Table 17, “Chip Enable Truth Table for 32-, 64-, 128-Mb” on page 30](#)).
- Read timing characteristics during block erase, program, and lock-bit configuration operations are the same as during read-only operations. Refer to *AC Characteristics—Read-Only Operations*.
- A write operation can be initiated and terminated with either CE<sub>X</sub> or WE#.
- Sampled, not 100% tested.
- Write pulse width ( $t_{WP}$ ) is defined from CE<sub>X</sub> or WE# going low (whichever goes low last) to CE<sub>X</sub> or WE# going high (whichever goes high first). Hence,  $t_{WP} = t_{WLWH} = t_{ELEH} = t_{WLEH} = t_{ELWH}$ .
- Refer to [Table 18, “Enhanced Configuration Register” on page 32](#) for valid A<sub>IN</sub> and D<sub>IN</sub> for block erase, program, or lock-bit configuration.
- Write pulse width high ( $t_{WPH}$ ) is defined from CE<sub>X</sub> or WE# going high (whichever goes high first) to CE<sub>X</sub> or WE# going low (whichever goes low first). Hence,  $t_{WPH} = t_{WHWL} = t_{EHEL} = t_{WHEL} = t_{EHWL}$ .
- For array access,  $t_{AVQV}$  is required in addition to  $t_{WHGL}$  for any accesses after a write.
- STS timings are based on STS configured in its RY/BY# default mode.
- V<sub>PEN</sub> should be held at V<sub>PENH</sub> until determination of block erase, program, or lock-bit configuration success (SR[5:3,1] = 0).

Figure 10: Asynchronous Write Waveform

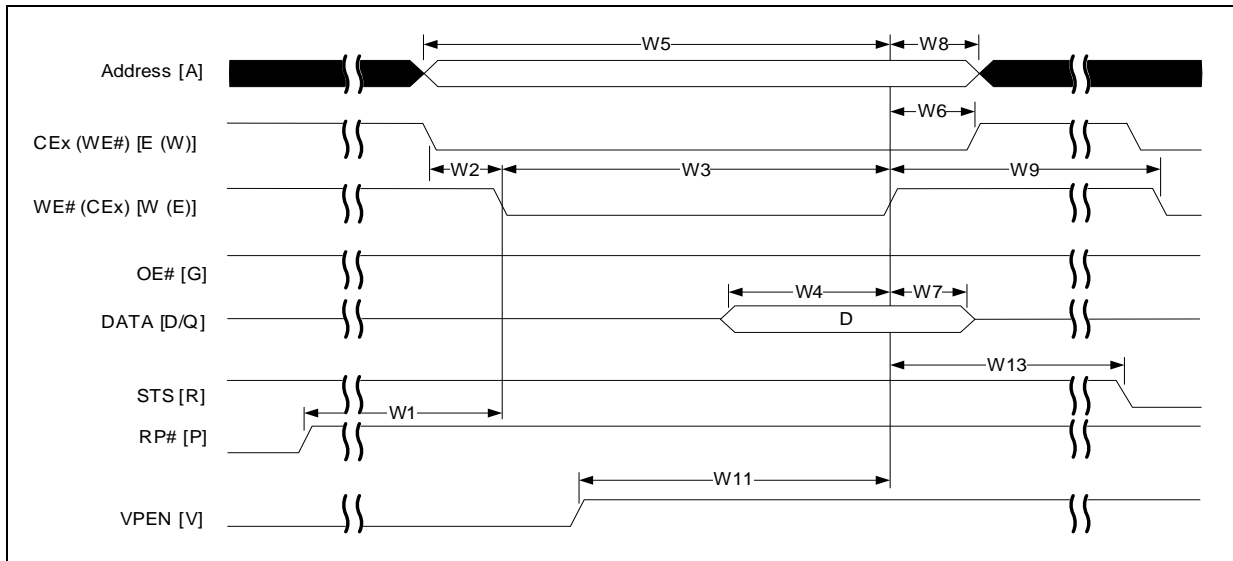
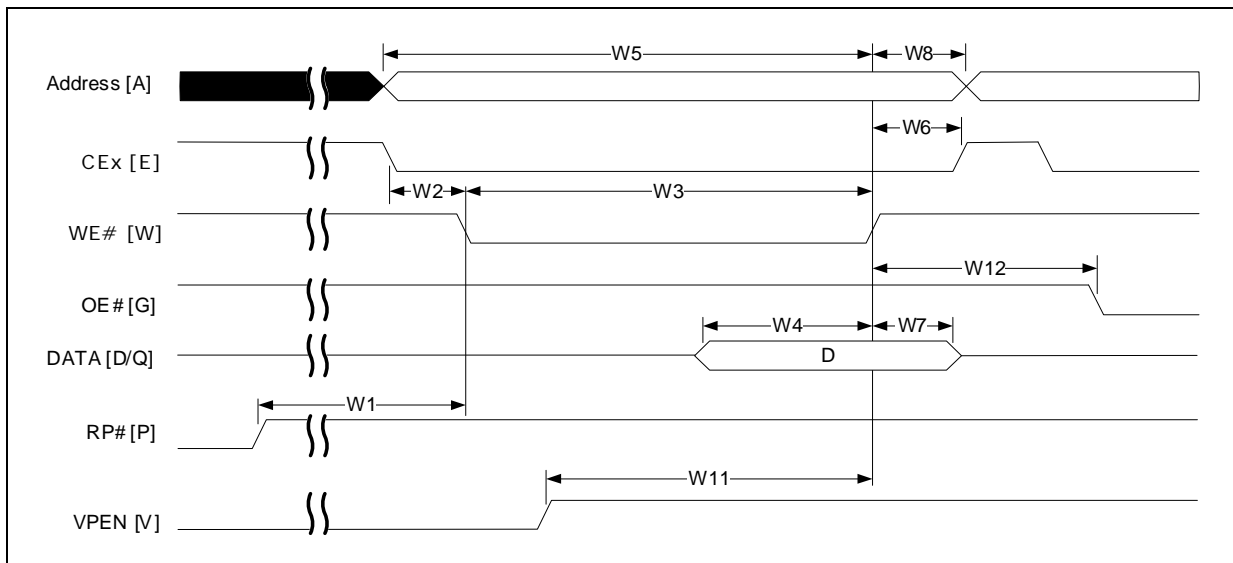

Figure 11: Asynchronous Write to Read Waveform



## 7.2 Program, Erase, Block-Lock Specifications

Table 13: Configuration Performance

#	Symbol	Parameter		Typ	Max	Unit	Notes
W200	$t_{\text{PROG/W}}$	Program Time	Single word	40	175	$\mu\text{s}$	1,2,3,4,6
W250	$t_{\text{PROG}}$	Buffer Program Time	Aligned 16 Words BP Time (32 Bytes)	128	654	$\mu\text{s}$	1,2,3,4,5,6
			Aligned 128 Words BP Time (256 Bytes)	400	2000	$\mu\text{s}$	1,2,3,4,5,6
			Aligned 256 Words BP Time	720	3600	$\mu\text{s}$	1,2,3,4,5,6
W501	$t_{\text{ERS/AB}}$	Block Erase Time		1.0	4.0	sec	1,2,3,4,6
W650	$t_{\text{IKS}}$	Set Lock-Bit Time		50	60	$\mu\text{s}$	1,2,3,4,6
W651	$t_{\text{IKC}}$	Clear Block Lock-Bits Time		0.5	1	sec	1,2,3,4,6
W600	$t_{\text{SUSP/P}}$	Program Suspend Latency Time to Read		15	20	$\mu\text{s}$	1,2,3,6
W601	$t_{\text{SUSP/E}}$	Erase Suspend Latency Time to Read		15	20	$\mu\text{s}$	1,2,3,6
W602	$t_{\text{ERS/SUSP}}$	Erase to Suspend		500	—	$\mu\text{s}$	1,7
W652	$t_{\text{STS}}$	STS Pulse Width Low Time		500	—	ns	1
W702	$t_{\text{BC/MB}}$	blank check	Array Block	3.2	—	ms	—

**Notes:**

1. Typical values measured at  $T_A = +25\text{ }^\circ\text{C}$  and nominal voltages. Assumes corresponding lock-bits are not set. Subject to change based on device characterization.
2. These performance numbers are valid for all speed versions.
3. Sampled but not 100% tested.
4. Excludes system-level overhead.
5. These values are valid when the buffer is full, and the start address is aligned.
6. Max values are measured at worst case temperature, data pattern and  $V_{\text{CC}}$  corner within 100K cycles. But for W650, W651, W600 and W601, the Max value are expressed at  $+25\text{ }^\circ\text{C}$  or  $-40\text{ }^\circ\text{C}$ .
7. W602 is the typical time between an initial block erase or erase resume command and then a subsequent erase suspend command. Violating the specification repeatedly during any particular block erase may cause erase failures.

## 7.3 Reset Specifications

Figure 12: AC Waveform for Reset Operation

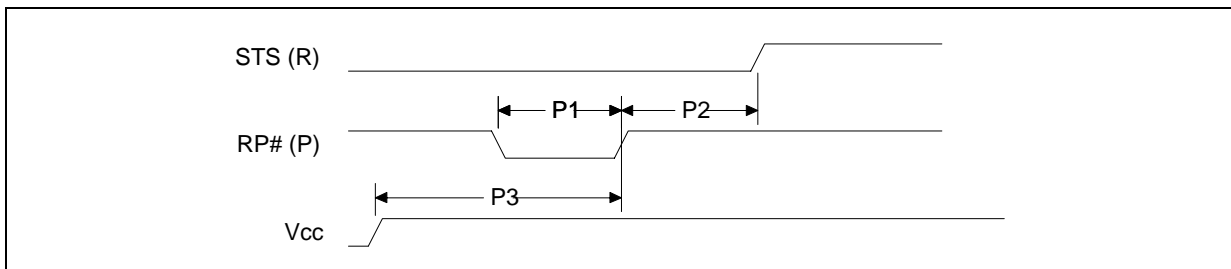

**Note:** STS is shown in its default mode (RY/BY#).

**Table 14: Reset Specifications**

#	Symbol	Parameter		Min	Max	Unit	Notes
P1	$t_{PLPH}$	RP# Pulse Low Time (If RP# is tied to $V_{CC}$ , this specification is not applicable)	RP# is asserted during block erase, program or lock-bit configuration operation	25	—	$\mu$ s	1
			RP# is asserted during read	100	—	ns	1
P2	$t_{PHRH}$	RP# High to Reset during Block Erase, Program, or Lock-Bit Configuration		—	100	ns	1,2
P3	$t_{VCCPH}$	$V_{CC}$ Power Valid to RP# de-assertion (high)		60	—	$\mu$ s	—

**Notes:**

1. These specifications are valid for all product versions (packages and speeds).
2. A reset time,  $t_{PHQV}$ , is required from the latter of STS (in RY/BY# mode) or RP# going high until outputs are valid.

## 7.4 AC Test Conditions

**Figure 13: AC Input/Output Reference Waveform**

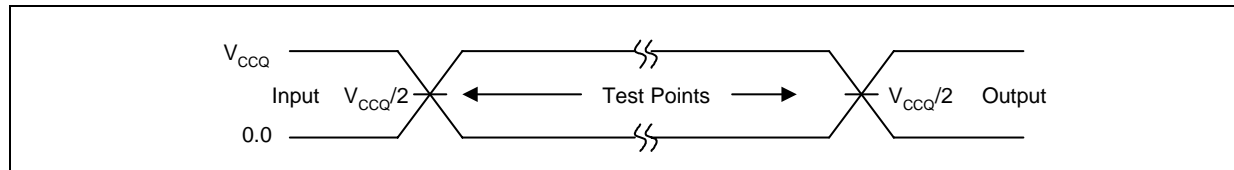

**Note:** AC test inputs are driven at  $V_{CCQ}$  for a Logic "1" and 0.0 V for a Logic "0." Input timing begins, and output timing ends, at  $V_{CCQ}/2$  V (50% of  $V_{CCQ}$ ). Input rise and fall times (10% to 90%) < 5 ns.

**Figure 14: Transient Equivalent Testing Load Circuit**

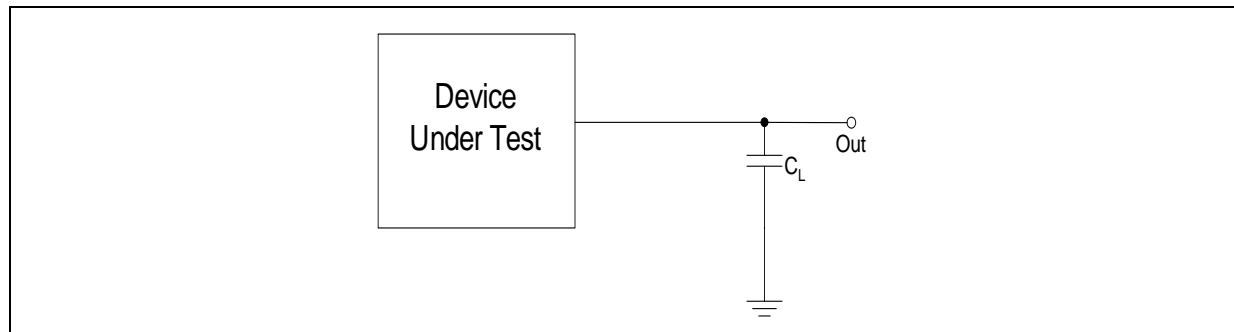

**Note:**  $C_L$  Includes Jig Capacitance

**Table 15: Test Configuration**

Test Configuration	$C_L$ (pF)
$V_{CCQ} = V_{CCQMIN}$	30

## 8.0 Bus Interface

This section provides an overview of Bus operations. The on-chip Write State Machine (WSM) manages all erase and program algorithms. The system CPU provides control of all in-system read, write, and erase operations through the system bus. All bus cycles to or from the flash memory conform to standard microprocessor bus cycles. Table 16 summarizes the necessary states of each control signal for different modes of operations.

**Table 16: Bus Operations**

Mode	RP#	CE <sub>x</sub> <sup>(1)</sup>	OE# <sup>(2)</sup>	WE# <sup>(2)</sup>	V <sub>PEN</sub>	DQ <sub>15:0</sub> <sup>(3)</sup>	STS (Default Mode)	Notes
Async., Status, Query and Identifier Reads	V <sub>IH</sub>	Enabled	V <sub>IL</sub>	V <sub>IH</sub>	X	D <sub>OUT</sub>	High Z	4,6
Output Disable	V <sub>IH</sub>	Enabled	V <sub>IH</sub>	V <sub>IH</sub>	X	High Z	High Z	—
Standby	V <sub>IH</sub>	Disabled	X	X	X	High Z	High Z	—
Reset/Power-down	V <sub>IL</sub>	X	X	X	X	High Z	High Z	—
Command Writes	V <sub>IH</sub>	Enabled	V <sub>IH</sub>	V <sub>IL</sub>	X	D <sub>IN</sub>	High Z	6,7
Array Writes	V <sub>IH</sub>	Enabled	V <sub>IH</sub>	V <sub>IL</sub>	V <sub>PENH</sub>	X	V <sub>IL</sub>	5,8

**Notes:**

1. See Table 17 for valid CE<sub>x</sub> configurations.
2. OE# and WE# should never be asserted simultaneously. If done so, OE# overrides WE#.
3. DQ refers to DQ[7:0] when BYTE# is low and DQ[15:0] if BYTE# is high.
4. Refer to DC characteristics. When V<sub>PEN</sub> ≤ V<sub>PENLK</sub>, memory contents can be read but not altered.
5. X should be V<sub>IL</sub> or V<sub>IH</sub> for the control pins and V<sub>PENLK</sub> or V<sub>PENH</sub> for V<sub>PEN</sub>. For outputs, X should be V<sub>OL</sub> or V<sub>OH</sub>.
6. In default mode, STS is V<sub>OL</sub> when the WSM is executing internal block erase, program, or a lock-bit configuration algorithm. It is V<sub>OH</sub> (pulled up by an external pull up resistance ≈ 10k) when the WSM is not busy, in block erase suspend mode (with programming inactive), program suspend mode, or reset power-down mode.
7. See Section 11.0, "Device Command Codes" on page 47 for valid DIN (user commands) during a Write operation.
8. Array writes are either program or erase operations.

**Table 17: Chip Enable Truth Table for 32-, 64-, 128-Mb**

CE2	CE1	CE0	DEVICE
V <sub>IL</sub>	V <sub>IL</sub>	V <sub>IL</sub>	Enabled
V <sub>IL</sub>	V <sub>IL</sub>	V <sub>IH</sub>	Disabled
V <sub>IL</sub>	V <sub>IH</sub>	V <sub>IL</sub>	Disabled
V <sub>IL</sub>	V <sub>IH</sub>	V <sub>IH</sub>	Disabled
V <sub>IH</sub>	V <sub>IL</sub>	V <sub>IL</sub>	Enabled
V <sub>IH</sub>	V <sub>IL</sub>	V <sub>IH</sub>	Enabled
V <sub>IH</sub>	V <sub>IH</sub>	V <sub>IL</sub>	Enabled
V <sub>IH</sub>	V <sub>IH</sub>	V <sub>IH</sub>	Disabled

**Note:** For single-chip applications, CE2 and CE1 can be connected to VSS.

## 8.1 Bus Reads

Reading from flash memory outputs stored information to the processor or chipset, and does not change any contents. Reading can be performed an unlimited number of times. Besides array data, other types of data such as device information and device status are available from the flash.

To perform a bus read operation, CEx (refer to [Table 17 on page 30](#)) and OE# must be asserted. CEx is the device-select control; when active, it enables the flash memory device. OE# is the data-output control; when active, the addressed flash memory data is driven onto the I/O bus. For all read states, WE# and RP# must be de-asserted. See [Section 9.2, “Read Operations” on page 35](#).

### 8.1.1 Asynchronous Page Mode Read

Unlike J3 130nm devices, J3 65 nm SBC device provides Eight-Word Asynchronous Page mode only. Array data can be sensed up to eight words (16 Bytes) at a time. This is the default mode on power-up or reset.

On J3 130nm devices, the Set Enhanced Configuration Register command is used to enable Eight-Word Page mode upon power-up or reset, however this has no effect on J3 65 nm SBC device anymore.

After the initial access delay, the first word out of the page buffer corresponds to the initial address. Address bits A[3:1] determine which word is output from the page buffer for a x16 bus width, and A[3:0] determine which byte is output from the page buffer for a x8 bus width. Subsequent reads from the device come from the page buffer. These reads are output on DQ[15:0] for a x16 bus width and DQ[7:0] for a x8 bus width after a minimum delay by changing A[3:1] or A[3:0].

Data can be read from the page buffer multiple times, and in any order. If address bits A[MAX:4] change at any time, or if CEx# is toggled, the device will sense and load new data into the page buffer. Asynchronous Page mode is the default read mode on power-up or reset.

To perform a Page mode read after any other operation, the Read Array command must be issued to read from the flash array. Asynchronous Page mode reads are permitted in all blocks and are used to access register information. During register access, only one word is loaded into the page buffer.

#### 8.1.1.1 Enhanced Configuration Register

The Enhanced Configuration Register (ECR) is a volatile storage register that when addressed by the Set ECR command can select between Four-Word Page mode and Eight-Word Page mode on J3 130nm devices, however this has no effect on J3 65 nm SBC device.

The ECR is volatile; all bits will be reset to default values when RP# is deasserted or power is removed from the device. To modify ECR settings, use the Set ECR command. The Set ECR command is written along with the configuration register value, which is placed on the lower 16 bits of the address bus A[16:1]. This is followed by a second write that confirms the operation and again presents the ECR data on the address bus. After executing this command, the device returns to Read Array mode.

The ECR is shown in [Table 18](#). 8-word page mode Command Bus-Cycle is captured in [Table 19](#) for backward compatibility reasons.

*Note:* If the 8-word Asynchronous Page mode is used on J3 65 nm SBC, a Clear Status Register command must be executed after issuing the Set ECR command.

**Table 18: Enhanced Configuration Register**

Reserved		Page Length	Reserved												
ECR 15	ECR 14	ECR 13	ECR 12	ECR 11	ECR 10	ECR 9	ECR 8	ECR 7	ECR 6	ECR 5	ECR 4	ECR 3	ECR 2	ECR 1	ECR 0
BITS		DESCRIPTION										NOTES			
ECR[15:14]		RFU										All bits should be set to 0.			
ECR.13		<ul style="list-style-type: none"> <li>• "1" = 8-Word Page mode</li> <li>• "0" = 8-Word Page mode (Default)</li> </ul>										Either "1" or "0" is for 8-word sense in page mode.			
ECR[12:0]		RFU										All bits should be set to 0.			

**Table 19: Asynchronous 8-Word Page Mode Command Bus-Cycle Definition**

Command	Bus Cycles Required	First Bus Cycle			Second Bus Cycle		
		Oper	Addr <sup>(1)</sup>	Data	Oper	Addr <sup>(1)</sup>	Data
Set Enhanced Configuration Register (Set ECR)	2	Write	ECD	0060h	Write	ECD	0004h

1. ECD = Enhanced Configuration Register Data

### 8.1.2 Output Disable

With CEx asserted, and OE# at a logic-high level (V<sub>IH</sub>), the device outputs are disabled. Output signals DQ[15:0] are placed in a high-impedance state.

## 8.2 Bus Writes

Writing or Programming to the device, is where the host writes information or data into the flash device for non-volatile storage. When the flash device is programmed, 'ones' are changed to 'zeros'. 'Zeros' cannot be programmed back to 'ones'. To do so, an erase operation must be performed. Writing commands to the Command User Interface (CUI) enables various modes of operation, including the following:

- Reading of array data
- Common Flash Interface (CFI) data
- Identifier codes, inspection, and clearing of the Status Register
- Block Erasure, Program, and Lock-bit Configuration (when V<sub>PEN</sub> = V<sub>PENH</sub>)

Erasing is performed on a block basis – all flash cells within a block are erased together. Any information or data previously stored in the block will be lost. Erasing is typically done prior to programming. The Block Erase command requires appropriate command data and an address within the block to be erased. The Byte/Word Program command requires the command and address of the location to be written. Set Block Lock-Bit commands require the command and block within the device to be locked. The Clear Block Lock-Bits command requires the command and address within the device to be cleared.

The CUI does not occupy an addressable memory location. It is written when the device is enabled and WE# is active. The address and data needed to execute a command are latched on the rising edge of WE# or CE<sub>x</sub> (CE<sub>x</sub> low is defined as the combination of pins CE0, CE1, and CE2 that enable the device. CE<sub>x</sub> high is defined as the combination of pins CE0, CE1, and CE2 that disable the device. See [Table 17 on page 30](#)). Standard microprocessor write timings are used.

## 8.3 Standby

CE0, CE1, and CE2 can disable the device (see [Table 17 on page 30](#)) and place it in standby mode. This manipulation of CEx substantially reduces device power consumption. DQ[15:0] outputs are placed in a high-impedance state independent of OE#. If deselected during block erase, program, or lock-bit configuration, the WSM continues functioning, and consuming active power until the operation completes.

### 8.3.1 Reset/Power-Down

RP# at  $V_{IL}$  initiates the reset/power-down mode.

In read modes, RP#-low deselects the memory, places output drivers in a high-impedance state, and turns off numerous internal circuits. RP# must be held low for a minimum of  $t_{PLPH}$ . Time  $t_{PHQV}$  is required after return from reset mode until initial memory access outputs are valid. After this wake-up interval, normal operation is restored. The CUI is reset to read array mode and Status Register is set to 0080h.

During Block Erase, Program, or Lock-Bit Configuration modes, RP#-low will abort the operation. In default mode, STS transitions low and remains low for a maximum time of  $t_{PLPH} + t_{PHRH}$  until the reset operation is complete. Memory contents being altered are no longer valid; the data may be partially corrupted after a program or partially altered after an erase or lock-bit configuration. Time  $t_{PHWL}$  is required after RP# goes to logic-high ( $V_{IH}$ ) before another command can be written.

As with any automated device, it is important to assert RP# during system reset. When the system comes out of reset, it expects to read from the flash memory. Automated flash memories provide status information when accessed during Block Erase, Program, or Lock-Bit Configuration modes. If a CPU reset occurs with no flash memory reset, proper initialization may not occur because the flash memory may be providing status information instead of array data. Numonyx Flash memories allow proper initialization following a system reset through the use of the RP# input. In this application, RP# is controlled by the same RESET# signal that resets the system CPU.

## 8.4 Device Commands

When  $V_{PEN} \leq V_{PENLK}$ , only read operations from the Status Register, CFI, identifier codes, or blocks are enabled. Placing  $V_{PENH}$  on  $V_{PEN}$  additionally enables block erase, program, and lock-bit configuration operations. Device operations are selected by writing specific commands to the Command User Interface (CUI). The CUI does not occupy an addressable memory location. It is the mechanism through which the flash device is controlled.

A command sequence is issued in two consecutive write cycles - a Setup command followed by a Confirm command. However, some commands are single-cycle commands consisting of a setup command only. Generally, commands that alter the contents of the flash device, such as Program or Erase, require at least two write cycles to guard against inadvertent changes to the flash device. Flash commands fall into two categories: Basic Commands and Extended Commands. Basic commands are recognized by all Numonyx Flash devices, and are used to perform common flash operations such as selecting the read mode, programming the array, or erasing blocks. Extended commands are product-dependant; they are used to perform additional features such as software block locking. [Section 11.0, "Device Command Codes" on page 47](#) describes all applicable commands on J3 65 nm SBC device.

## 9.0 Flash Operations

This section describes the operational features of flash memory. Operations are command-based, wherein command codes are first issued to the device, then the device performs the desired operation. All command codes are issued to the device using bus-write cycles (see [Chapter 8.0, "Bus Interface"](#)). A complete list of available command codes can be found in [Section 11.0, "Device Command Codes" on page 47](#).

### 9.1 Status Register

The Status Register (SR) is an 8-bit, read-only register that indicates device status and operation errors. To read the Status Register, issue the Read Status Register command. Subsequent reads output Status Register information on DQ[7:0], and 00h on DQ[15:8].

SR *status bits* are set and cleared by the device. SR *error bits* are set by the device, but must be cleared using the Clear Status Register command. Upon power-up or exit from reset, the Status Register defaults to 80h. Page-mode reads are not supported in this read mode. Status Register contents are latched on the falling edge of OE# or CE<sub>X</sub> (CE<sub>X</sub> low is defined as the combination of pins CE0, CE1, and CE2 that enable the device. CE<sub>X</sub> high is defined as the combination of pins CE0, CE1, and CE2 that disable the device). OE# must toggle to V<sub>IH</sub> or the device must be disabled before further reads to update the Status Register latch. The Read Status Register command functions independently of V<sub>PEN</sub> voltage.

[Table 20](#) shows Status Register bit definitions.

**Table 20: Status Register Bit Definitions**

Status Register (SR)				Default Value = 80h			
Ready Status	Erase Suspend Status	Erase Error	Program Error	Program/ Erase Voltage Error	Program Suspend Status	Block-Locked Error	Reserved
7	6	5	4	3	2	1	0
Bit	Name		Description				
7	Ready Status		0 = Device is busy. SR[6:0] are invalid (Not driven); 1 = Device is ready. SR[6:0] are valid.				
6	Erase Suspend Status		0 = Erase suspend not in effect. 1 = Erase suspend in effect.				
5	Erase Error	Command Sequence Error	SR.5 SR.4				
4	Program Error		0 0 = Program or erase operation successful. 0 1 = Program error - operation aborted. 1 0 = Erase error - operation aborted. 1 1 = Command sequence error - command aborted.				
3	Program/Erased Voltage Error		0 = Within acceptable limits during program or erase operation. 1 = Not within acceptable limits during program or erase operation - Operation aborted.				
2	Program Suspend Status		0 = Program suspend not in effect. 1 = Program suspend in effect.				
1	Block-Locked Error		0 = Block NOT locked during program or erase - operation successful. 1 = Block locked during program or erase - operation aborted.				
0	Reserved		Reserved				

### 9.1.1 Clearing the Status Register

The Status Register (SR) contain Status and error bits which are set by the device. SR *status bits* are cleared by the device, however SR *error bits* are cleared by issuing the Clear SR command (see [Table 21](#)). Resetting the device also clears the SR.

**Table 21: Clear Status Register Command Bus-Cycles**

Command	Setup Write Cycle		Confirm Write Cycle	
	Address Bus	Data Bus	Address Bus	Data Bus
Clear Status Register	Device Address	0050h	—	—

Issuing the Clear SR command places the device in Read SR mode.

*Note:* Care should be taken to avoid SR ambiguity. If a command sequence error occurs while in an Erase Suspend condition, the SR will indicate a Command Sequence error by setting SR.4 and SR.5. When the erase operation is resumed (and finishes), any errors that may have occurred during the erase operation will be masked by the Command Sequence error. To avoid this situation, clear the Status Register prior to resuming a suspended erase operation. The Clear SR command functions independent of the voltage level on VPEN.

## 9.2 Read Operations

Four types of data can be read from the device: array data, device information, CFI data, and device status. Upon power-up or return from reset, the device defaults to Read Array mode. To change the device's read mode, the appropriate command must be issued to the device. [Table 22](#) shows the command codes used to configure the device for the desired read mode. The following sections describe each read mode.

**Table 22: Read Mode Command Bus-Cycles**

Command	Setup Write Cycle		Confirm Write Cycle	
	Address Bus	Data Bus	Address Bus	Data Bus
Read Array	Device Address	00FFh	—	—
Read Status Register	Device Address	0070h	—	—
Read Device Information	Device Address	0090h	—	—
CFI Query	Device Address	0098h	—	—

### 9.2.1 Read Array

Upon power-up or return from reset, the device defaults to Read Array mode. Issuing the Read Array command places the device in Read Array mode. Subsequent reads output array data on DQ[15:0]. The device remains in Read Array mode until a different read command is issued, or a program or erase operation is performed, in which case, the read mode is automatically changed to Read Status.

To change the device to Read Array mode while it is programming or erasing, first issue the Suspend command. After the operation has been suspended, issue the Read Array command. When the program or erase operation is subsequently resumed, the device will automatically revert back to Read Status mode.

*Note:* Issuing the Read Array command to the device while it is actively programming or erasing causes subsequent reads from the device to output invalid data. Valid array data is output only after the program or erase operation has finished.

The Read Array command functions independent of the voltage level on VPEN.

## 9.2.2 Read Status Register

Issuing the Read Status Register command places the device in Read Status Register mode. Subsequent reads output Status Register information on DQ[7:0], and 00h on DQ[15:8]. The device remains in Read Status Register mode until a different read-mode command is issued. Performing a program, erase, or block-lock operation also changes the device's read mode to Read Status Register mode.

The Status Register is updated on the falling edge of OE# or CEx, whichever occurs last. Status Register contents are valid only when SR.7 = 1. When WSM is active, SR.7 indicates the WSM's state and SR[6:0] are in high-Z state.

The Read Status Register command functions independent of the voltage level on VPEN.

## 9.2.3 Read Device Information

Issuing the Read Device Information command places the device in Read Device Information mode. Subsequent reads output device information on DQ[15:0].

The device remains in Read Device Information mode until a different read command is issued. Also, performing a program, erase, or block-lock operation changes the device to Read Status Register mode.

The Read Device Information command functions independent of the voltage level on VPEN.

## 9.2.4 CFI Query

The CFI query table contains an assortment of flash product information such as block size, density, allowable command sets, electrical specifications, and other product information. The data contained in this table conforms to the CFI protocol.

Issuing the CFI Query command places the device in CFI Query mode. Subsequent reads output CFI information on DQ[15:0]. The device remains in CFI Query mode until a different read command is issued, or a program or erase operation is performed, which changes the read mode to Read Status Register mode.

The CFI Query command functions independent of the voltage level on VPEN.

## 9.3 Programming Operations

All programming operations require the addressed block to be unlocked, and a valid VPEN voltage applied throughout the programming operation. Otherwise, the programming operation will abort, setting the appropriate Status Register error bit(s).

The following sections describe each programming method.

### 9.3.1 Single-Word/Byte Programming

Array programming is performed by first issuing the Single-Word/Byte Program command. This is followed by writing the desired data at the desired array address. The read mode of the device is automatically changed to Read Status Register mode, which remains in effect until another read-mode command is issued.

During programming, STS and the Status Register indicate a busy status (SR.7 = 0). Upon completion, STS and the Status Register indicate a ready status (SR.7 = 1). The Status Register should be checked for any errors (SR.4), then cleared.

*Note:* Issuing the Read Array command to the device while it is actively programming causes subsequent reads from the device to output invalid data. Valid array data is output only after the program operation has finished.

Standby power levels are not be realized until the programming operation has finished. Also, asserting RP# aborts the programming operation, and array contents at the addressed location are indeterminate. The addressed block should be erased, and the data re-programmed. If a Single-Word/Byte program is attempted when the corresponding block lock-bit is set, SR.1 and SR.4 will be set.

### 9.3.2 Buffered Programming

Buffered programming operations simultaneously program multiple words/bytes into the flash memory array, significantly reducing effective word-write/byte-write times. User-data is first written to a write buffer, then programmed into the flash memory array in buffer-size increments. For additional details, see the flow chart of the buffered-programming operation.

Optimal performance and power consumption is realized by aligning the start address on 256-Word boundaries (i.e., A[8:1] = 00000000b). Crossing a 256-Word boundary during a buffered programming operation can cause programming time to double.

To perform a buffered programming operation, first issue the Buffered Program setup command at the desired starting address. The read mode of the device/addressed partition is automatically changed to Read Status Register mode.

Polling SR.7 determines write-buffer availability (0 = not available, 1 = available). If the write buffer is not available, re-issue the setup command and check SR.7; repeat until SR.7 = 1.

*Note:* The device defaults to output SR data after the Buffered Programming Setup command (E8h) is issued. CE# and OE# must be toggled to update Status Register. Don't issue the Read SR command (70h), which would be interpreted by the internal state machine as Buffer Word Count.

Next, issue the word count at the desired starting address. The word count represents the total number of words to be written into the write buffer, minus one. This value can range from 00h (one) to a maximum of FFh (256). Exceeding the allowable range causes an abort.

*Note:* The maximum number of bytes in write buffer on CFI region (offset 2Ah, refer [Table 41, "Device Geometry Definition" on page 60](#)) is set to 05h (32 bytes) for backward compatible reasons. No software change is required on existing applications for both x8 and x16 mode. Applications can optimize the system performance using the maximum of 256 buffer size. Please contact your sales representatives for questions.

Following the word count, the write buffer is filled with user-data. Subsequent bus-write cycles provide addresses and data, up to the word count. All user-data addresses must lie between <starting address> and <starting address + word count>, otherwise the WSM continues to run as normal but, user may advertently change the content in unexpected address locations.

*Note:* User-data is programmed into the flash array at the address issued when filling the write buffer.

After all user-data is written into the write buffer, issue the confirm command. If a command other than the confirm command is issued to the device, a command sequence error occurs and the operation aborts.

*Note:* After issuing the confirm command, write-buffer contents are programmed into the flash memory array. The Status Register indicates a busy status (SR.7 = 0) during array programming. Issuing the Read Array command to the device while it is actively programming or erasing causes subsequent reads from the device to output invalid data. Valid array data is output only after the program or erase operation has finished.

Upon completion of array programming, the Status Register indicates ready (SR.7 = 1). A full Status Register check should be performed to check for any programming errors, then cleared by using the Clear Status Register command.

Additional buffered programming operations can be initiated by issuing another setup command, and repeating the buffered programming bus-cycle sequence. However, any errors in the Status Register must first be cleared before another buffered programming operation can be initiated.

## 9.4 Block Erase Operations

Erasing a block changes 'zeros' to 'ones'. To change ones to zeros, a program operation must be performed (See Section 9.3, "Programming Operations"). Erasing is performed on a block basis - an entire block is erased each time an erase command sequence is issued. Once a block is fully erased, all addressable locations within that block read as logical ones (FFFFh for x16 mode, FFh for x8 mode). Only one block-erase operation can occur at a time, and *is not* permitted during a program suspend.

To perform a block-erase operation, issue the Block Erase command sequence at the desired block address. Table 23 shows the two-cycle Block Erase command sequence.

**Table 23: Block-Erase Command Bus-Cycles**

Command	Setup Write Cycle		Confirm Write Cycle	
	Address Bus	Data Bus	Address Bus	Data Bus
Block Erase	Block Address	0020h	Block Address	00D0h

*Note:* A block-erase operation requires the addressed block to be unlocked, and a valid voltage applied to VPEN throughout the block-erase operation. Otherwise, the operation will abort, setting the appropriate Status Register error bit(s).

The Erase Confirm command latches the address of the block to be erased. The addressed block is preconditioned (programmed to all zeros), erased, and then verified. The read mode of the device is automatically changed to Read Status Register mode, and remains in effect until another read-mode command is issued.

During a block-erase operation, STS and the Status Register indicates a busy status (SR.7 = 0). Upon completion, STS and the Status Register indicates a ready status (SR.7 = 1). The Status Register should be checked for any errors, then cleared. If any errors did occur, subsequent erase commands to the device are ignored unless the Status Register is cleared.

The only valid commands during a block erase operation are Read Array, Read Device Information, CFI Query, and Erase Suspend. After the block-erase operation has completed, any valid command can be issued.

*Note:* Issuing the Read Array command to the device while it is actively erasing causes subsequent reads from the device to output invalid data. Valid array data is output only after the block-erase operation has finished.

Standby power levels are not realized until the block-erase operation has finished. Also, asserting RP# aborts the block-erase operation, and array contents at the addressed location are indeterminate. The addressed block should be erased before programming within the block is attempted.

## 9.5 Blank Check

The Blank Check operation determines whether a specified array block is blank (i.e. completely erased). Without Blank Check, Block Erase would be the only other way to ensure a block is completely erased. Blank Check is especially useful in the case of erase operation interrupted by a power loss event.

Blank Check can apply to only one block at a time, and no operations other than Status Register Reads are allowed during Blank Check (e.g. reading array data, program, erase etc.). Suspend and resume operations are not supported during Blank Check, nor is Blank Check supported during any suspended operations.

Blank Check operations are initiated by writing the Block Blank Check command to the block address. Next, the Blank Check Confirm command is issued along with the same block address. When a successful command sequence is entered, the device automatically enters the Read Status State. The WSM then reads the entire specified block, and determines whether any bit in the block is programmed or over-erased.

The status register can be examined for Blank Check progress and errors by reading any address within the block being accessed. During a blank check operation, the Status Register indicates a busy status (SR.7 = 0). Upon completion, the Status Register indicates a ready status (SR.7 = 1). The Status Register should be checked for any errors, and then cleared. If the Blank Check operation fails, which means the block is not completely erased, the Status Register bit SR.5 will be set ("1"). CE# or OE# toggle (during polling) updates the Status Register.

The device remains in Status Register Mode until another command is written to the device. After examining the Status Register, it should be cleared by the Clear Status Register command before issuing a new command. Any command can follow once the Blank Check command is complete.

## 9.6 Suspend and Resume

An erase or programming operation can be suspended to perform other operations, and then subsequently resumed. [Table 24](#) shows the Suspend and Resume command bus-cycles.

*Note:* All erase and programming operations require the addressed block to remain unlocked with a valid voltage applied to VPEN throughout the suspend operation. Otherwise, the block-erase or programming operation will abort, setting the appropriate Status Register error bit(s). Also, asserting RP# aborts suspended block-erase and

programming operations, rendering array contents at the addressed location(s) indeterminate.

**Table 24: Suspend and Resume Command Bus-Cycles**

Command	Setup Write Cycle		Confirm Write Cycle	
	Address Bus	Data Bus	Address Bus	Data Bus
Suspend	Device Address	00B0h	—	—
Resume	Device Address	00D0h	—	—

To suspend an on-going erase or program operation, issue the Suspend command to any device address. The program or erase operation suspends at pre-determined points during the operation after a delay of  $t_{SUSP}$ . Suspend is achieved when STS (in RY/BY# mode) goes high,  $SR[7,6] = 1$  (erase-suspend) or  $SR[7,2] = 1$  (program-suspend).

*Note:* Issuing the Suspend command does not change the read mode of the device. The device will be in Read Status Register mode from when the erase or program command was first issued, unless the read mode was changed prior to issuing the Suspend command.

Not all commands are allowed when the device is suspended. [Table 25](#) shows which device commands are allowed during Program Suspend or Erase Suspend.

**Table 25: Valid Commands During Suspend**

Device Command	Program Suspend	Erase Suspend
STS Configuration	Allowed	Allowed
Read Array	Allowed	Allowed
Read Status Register	Allowed	Allowed
Clear Status Register	Allowed	Allowed
Read Device Information	Allowed	Allowed
CFI Query	Allowed	Allowed
Word/Byte Program	Not Allowed	Allowed
Buffered Program	Not Allowed	Allowed
Block Erase	Not Allowed	Not Allowed
Program Suspend	Not Allowed	Allowed
Erase Suspend	Not Allowed	Not Allowed
Program/Erase Resume	Allowed	Allowed
Lock Block	Not Allowed	Not Allowed
Unlock Block	Not Allowed	Not Allowed
Program OTP Register	Not Allowed	Not Allowed
Blank Check	Not Allowed	Not Allowed

During Suspend, array-read operations are not allowed in blocks being erased or programmed.

A block-erase under program-suspend is not allowed. However, word-program under erase-suspend is allowed, and can be suspended. This results in a simultaneous erase-suspend/ program-suspend condition, indicated by  $SR[7,6,2] = 1$ .

To resume a suspended program or erase operation, issue the Resume command to any device address. The read mode of the device is automatically changed to Read Status Register. The operation continues where it left off, STS (in RY/BY# mode) goes low, and the respective Status Register bits are cleared.

When the Resume command is issued during a simultaneous erase-suspend/ program-suspend condition, the programming operation is resumed first. Upon completion of the programming operation, the Status Register should be checked for any errors, and cleared. The resume command must be issued again to complete the erase operation. Upon completion of the erase operation, the Status Register should be checked for any errors, and cleared.

## 9.7 Status Signal

The STATUS (STS) signal can be configured to different states using the STS Configuration command (Table 26). Once the STS signal has been configured, it remains in that configuration until another Configuration command is issued or RP# is asserted low. Initially, the STS signal defaults to RY/BY# operation where RY/BY# low indicates that the WSM is busy. RY/BY# high indicates that the state machine is ready for a new operation or suspended. Table 27 displays possible STS configurations.

**Table 26: STS Configuration Register Command Bus-Cycles**

Command	Setup Write Cycle		Confirm Write Cycle	
	Address Bus	Data Bus	Address Bus	Data Bus
STS Configuration	Device Address	00B8h	Device Address	Register Data

To reconfigure the STATUS (STS) signal to other modes, the Configuration command is given followed by the desired configuration code. The three alternate configurations are all pulse mode for use as a system interrupt as described in the following paragraphs. For these configurations, bit 0 controls Erase Complete interrupt pulse, and bit 1 controls Program Complete interrupt pulse. Supplying the 00h configuration code with the Configuration command resets the STS signal to the default RY/BY# level mode. The Configuration command may only be given when the device is not busy or suspended. Check SR.7 for device status. An invalid configuration code will result in SR.4 and SR.5 being set.

*Note:* STS Pulse mode is not supported in the Clear Lock Bits and Set Lock Bit commands.

**Table 27: STS Configuration Register and Coding Definitions**

D7	D6	D5	D4	D3	D2	D1	D0
Reserved <sup>3</sup>						Pulse on Program Complete <sup>1</sup>	Pulse on Erase Complete <sup>1</sup>
D[1:0] = STS Configuration Codes <sup>2</sup>			Notes				
00 = default, level mode; device ready indication			Controls HOLD to a memory controller to prevent accessing a flash memory subsystem while any flash device's WSM is busy.				
01 = pulse on Erase Complete			Generates a system interrupt pulse when any flash device in an array has completed a block erase. Helpful for reformatting blocks after file system free space reclamation or "cleanup."				
10 = pulse on Program Complete			Not supported on this device.				
11 = pulse on Erase or Program Complete			Generates system interrupts to trigger servicing of flash arrays when either erase or program operations are completed, when a common interrupt service routine is desired.				

**Notes:**

1. When configured in one of the pulse modes, STS pulses low with a typical pulse width of 500 ns.
2. An invalid configuration code will result in both SR.4 and SR.5 being set.
3. Reserved bits are invalid should be ignored.

## 9.8 Security and Protection

J3 65 nm SBC device offers both hardware and software security features. Block lock operations, PRs and VPEN allow users to implement various levels of data protection.

### 9.8.1 Normal Block Locking

J3 65 nm SBC has the capability of Flexible Block Locking (locked blocks remain locked upon reset or power cycle): All blocks within the device are in unlocked state when ship from Numonyx. Blocks can be locked individually by issuing the Set Block Lock Bit command sequence to any address within a block. Once locked, blocks remain locked when power is removed, or when the device is reset.

All locked blocks are unlocked simultaneously by issuing the Clear Block Lock Bits command sequence to any device address. Locked blocks cannot be erased or programmed. [Table 28](#) summarizes the command bus-cycles.

**Table 28: Block Locking Command Bus-Cycles**

Command	Setup Write Cycle		Confirm Write Cycle	
	Address Bus	Data Bus	Address Bus	Data Bus
Set Block Lock Bit	Block Address	0060h	Block Address	0001h
Clear Block Lock Bits	Device Address	0060h	Device Address	00D0h

After issuing the Set Block Lock Bit setup command or Clear Block Lock Bits setup command, the device's read mode is automatically changed to Read Status Register mode. After issuing the confirm command, completion of the operation is indicated by STS (in RY/BY# mode) going high and SR.7 = 1.

Blocks cannot be locked or unlocked while programming or erasing, or while the device is suspended. Reliable block lock and unlock operations occur only when V<sub>CC</sub> and V<sub>PEN</sub> are valid. When V<sub>PEN</sub> ≤ V<sub>PENLK</sub>, block lock-bits cannot be changed.

When the set lock-bit operation is complete, SR.4 should be checked for any error. When the clear lock-bit operation is complete, SR.5 should be checked for any error. Errors bits must be cleared using the Clear Status Register command.

Block lock-bit status can be determined by first issuing the Read Device Information command, and then reading from <block base address> + 02h. DQ0 indicates the lock status of the addressed block (0 = unlocked, 1 = locked).

## 9.8.2 Configurable Block Locking

J3 65 nm SBC devices feature user-configurable block locking. This feature can be implemented to protect and/or secure the user's system. The user can individually set each block as Non-Volatile Temporary, Non-Volatile Semi-Permanent or Non-Volatile Permanent. For additional information and collateral, please contact the sales representative.

## 9.8.3 Password Access

Password Access is a security enhancement offered on the J3 65 nm SBC device. This feature protects information stored in main-array memory blocks by preventing content alteration or reads, until a valid 64-bit password is received. Password Access may be combined with Non-Volatile Protection and/or Volatile Protection to create a multi-tiered solution.

Please contact your Numonyx Sales for further details concerning Password Access.

## 9.8.4 128-bit OTP Protection Register

J3 65 nm SBC includes a 128-bit Protection Register (PR) that can be used to increase the security of a system design. For example, the number contained in the PR can be used to "match" the flash component with other system components such as the CPU or ASIC, hence preventing device substitution.

The 128-bits of the PR are divided into two 64-bit segments:

- One segment is programmed at the Numonyx factory with a unique unalterable 64-bit number.
- The other segment is left blank for customer designers to program as desired. Once the customer segment is programmed, it can be locked to prevent further programming.

## 9.8.5 Reading the 128-bit OTP Protection Register

The Protection Register is read in Identification Read mode. The device is switched to this mode by issuing the Read Identifier command (0090h). Once in this mode, read cycles from addresses shown in [Table 31, "Word-Wide Protection Register Addressing"](#) or [Table 32, "Byte-Wide Protection Register Addressing"](#) retrieve the specified information. To return to Read Array mode, write the Read Array command (00FFh).

## 9.8.6 Programming the 128-bit OTP Protection Register

PR bits are programmed using the two-cycle Program OTP Register command. The 64-bit number is programmed 16 bits at a time for word-wide configuration and eight bits at a time for byte-wide configuration. First write the Protection Program Setup command, 00C0h. The next write to the device will latch in address and data and program the specified location. The allowable addresses are shown in [Table 31, "Word-Wide Protection Register Addressing" on page 45](#) or [Table 32, "Byte-Wide Protection Register Addressing" on page 45](#). See [Figure 24, "Protection Register Programming"](#)

Flowchart” on page 56. Any attempt to address Program OTP Register command outside the defined PR address space will result in a Status Register error (SR.4 will be set). Attempting to program a locked PR segment will result in a Status Register error (SR.4 and SR.1 will be set).

**Table 29: Programming the 128-bit Protection Register Command Bus-Cycles**

Command	First Bus Cycle		Second Bus Cycle	
	Address Bus	Data Bus	Address Bus	Data Bus
Program OTP Register	Device Address	00C0h	Register Offset	Register Data

### 9.8.7 Locking the 128-bit OTP Protection Register

The user-programmable segment of the PR is lockable by programming Bit 1 of the Protection Lock Register (PLR) to 0. Bit 0 of this location is programmed to 0 at the Numonyx factory to protect the unique device number. Bit 1 is set using the Protection Program command to program “0xFFFD” to the PLR. After these bits have been programmed, no further changes can be made to the values stored in the Protection Register. Protection Program commands to a locked section will result in a Status Register error (SR.4 and SR.1 will be set). The PR lockout state is not reversible.

**Table 30: Programming Protection Lock Register Command Bus-Cycles**

Command	First Bus Cycle		Second Bus Cycle	
	Address Bus	Data Bus	Address Bus	Data Bus
Program OTP Register	Device Address	00C0h	80h	FFDh

**Figure 15: 128-bit Protection Register Memory Map**

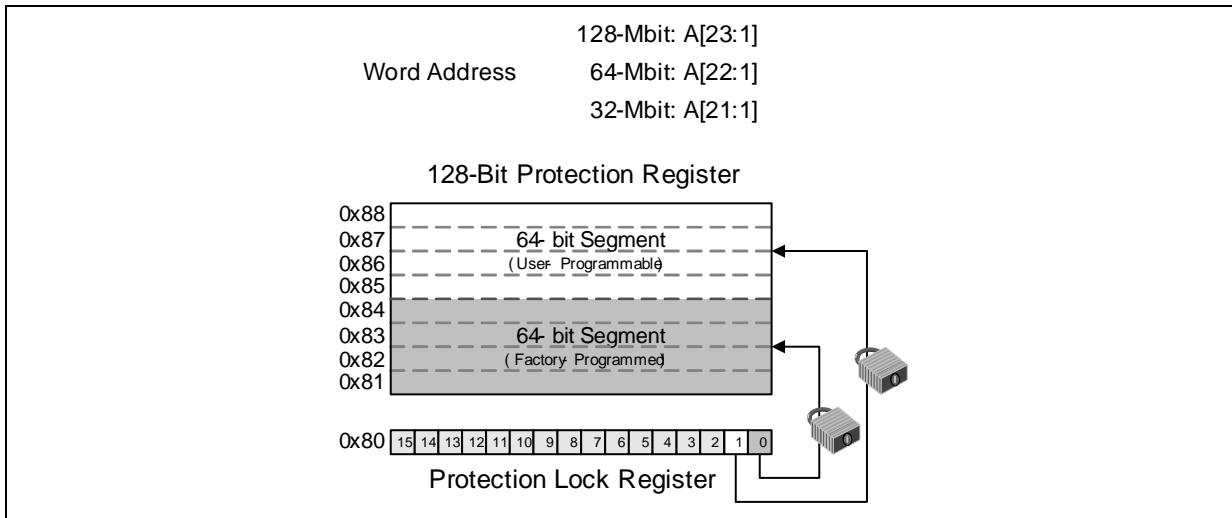

**Note:** A0 is not used in x16 mode when accessing the protection register map. See Table 31 for x16 addressing. In x8 mode A0 is used, see Table 32 for x8 addressing.

**Table 31: Word-Wide Protection Register Addressing**

Word	Use	A8	A7	A6	A5	A4	A3	A2	A1
LOCK	Both	1	0	0	0	0	0	0	0
0	Factory	1	0	0	0	0	0	0	1
1	Factory	1	0	0	0	0	0	1	0
2	Factory	1	0	0	0	0	0	1	1
3	Factory	1	0	0	0	0	1	0	0
4	User	1	0	0	0	0	1	0	1
5	User	1	0	0	0	0	1	1	0
6	User	1	0	0	0	0	1	1	1
7	User	1	0	0	0	1	0	0	0

**Note:** All address lines not specified in the above table must be 0 when accessing the Protection Register (i.e., A[MAX:9] = 0.)

**Table 32: Byte-Wide Protection Register Addressing**

Byte	Use	A8	A7	A6	A5	A4	A3	A2	A1	A0
LOCK	Both	1	0	0	0	0	0	0	0	0
LOCK	Both	1	0	0	0	0	0	0	0	1
0	Factory	1	0	0	0	0	0	0	1	0
1	Factory	1	0	0	0	0	0	0	1	1
2	Factory	1	0	0	0	0	0	1	0	0
3	Factory	1	0	0	0	0	0	1	0	1
4	Factory	1	0	0	0	0	0	1	1	0
5	Factory	1	0	0	0	0	0	1	1	1
6	Factory	1	0	0	0	0	1	0	0	0
7	Factory	1	0	0	0	0	1	0	0	1
8	User	1	0	0	0	0	1	0	1	0
9	User	1	0	0	0	0	1	0	1	1
A	User	1	0	0	0	0	1	1	0	0
B	User	1	0	0	0	0	1	1	0	1
C	User	1	0	0	0	0	1	1	1	0
D	User	1	0	0	0	0	1	1	1	1
E	User	1	0	0	0	1	0	0	0	0
F	User	1	0	0	0	1	0	0	0	1

**Note:** All address lines not specified in the above table must be 0 when accessing the Protection Register, i.e., A[MAX:9] = 0.

### 9.8.8 VPEN Protection

When it's necessary to protect the entire array, global protection can be achieved using a hardware mechanism using VPEN. Whenever a valid voltage is present on VPEN, blocks within the main flash array can be erased or programmed. By grounding VPEN, blocks within the main array cannot be altered – attempts to program or erase blocks will fail resulting in the setting of the appropriate error bit in the Status Register. By holding VPEN low, absolute write protection of all blocks in the array can be achieved.

## 10.0 ID Codes

**Table 33: Read Identifier Codes**

Code		Address	Data
Device Code	32-Mbit	00001h	0016h
	64-Mbit	00001h	0017h
	128-Mbit	00001h	0018h

## 11.0 Device Command Codes

For a complete definition on device operations refer to [Section 8.4, “Device Commands” on page 33](#). The list of all applicable commands are included here one more time for the convenience.

*Note:* Some customer applications use illegal or invalid commands (like 0x00) accidentally or intentionally with the device. An illegal or invalid command caused the device output to change to Array Read mode on 130nm. On the 65nm device, the output will change to Read Status Register mode.

After an illegal or invalid command, software may attempt to read the device. If the illegal command was intentional, software will expect to read array data on 130nm device, such as 0xFFFF in an unprogrammed location. On the 65nm device, software may not get the expected array data and instead the status register is read.

Please refer to the legal and valid commands/spec defined in the Datasheet, such as forread mode, issue 0xFF to Read Array mode, 0x90 to Read Signature, 0x98 to Read CFI/OTP array mode.

**Table 34: Command Bus Cycles and Command Codes**

Command		Setup Write Cycle		Confirm Write Cycle	
		Address Bus	Data Bus	Address Bus	Data Bus
Registers	Program Enhanced Configuration Register	Register Data	0060h	Register Data	0004h
	Program OTP Register	Device Address	00C0h	Register Offset	Register Data
	Clear Status Register	Device Address	0050h	—	—
	Program STS Configuration Register	Device Address	00B8h	Device Address	Register Data
Read Modes	Read Array	Device Address	00FFh	—	—
	Read Status Register	Device Address	0070h	—	—
	Read Identifier Codes (Read Device Information)	Device Address	0090h	—	—
	CFI Query	Device Address	0098h	—	—
Program and Erase	Word/Byte Program	Device Address	0040h/ 0010h	Device Address	Array Data
	Buffered Program	Block Address	00E8h	Block Address	00D0h
	Block Erase	Block Address	0020h	Block Address	00D0h
	Program/Erase Suspend	Device Address	00B0h	—	—
	Program/Erase Resume	Device Address	00D0h	—	—
Security	Set Block Lock Bit	Block Address	0060h	Block Address	0001h
	Clear Block Lock Bits	Device Address	0060h	Device Address	00D0h
Blank Check	Blank Check	Block Address	00BCh	Block Address	00D0h

## 12.0 Flow Charts

Figure 16: Write to Buffer Flowchart

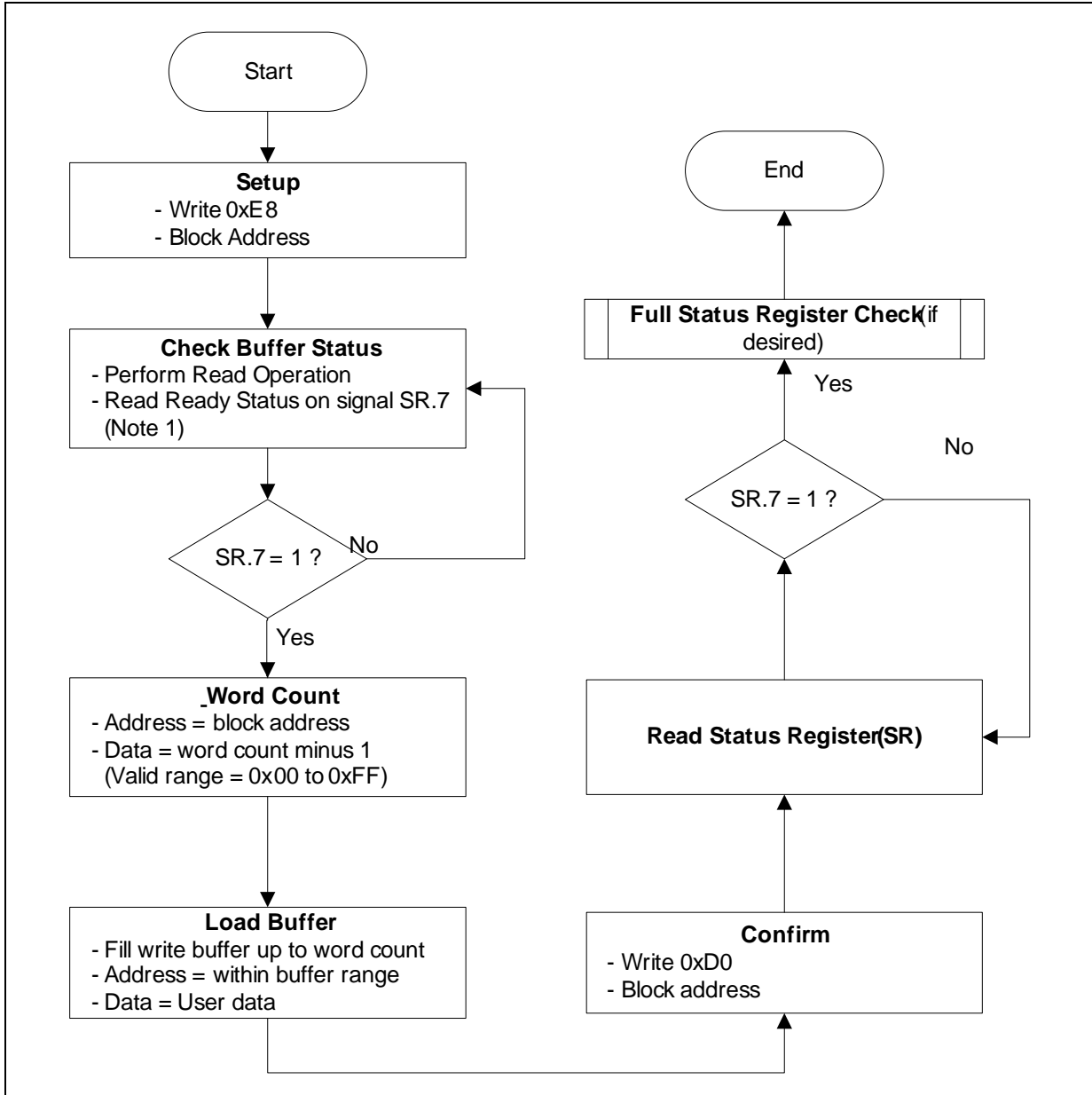

**Notes:**

1. The device defaults to output SR data after the Buffered Programming Setup command (E8h) is issued. CE# and OE# must be toggled to update Status Register. Don't issue the Read SR command (70h), which would be interpreted by the internal state machine as Buffer Word Count.

Figure 17: Status Register Flowchart

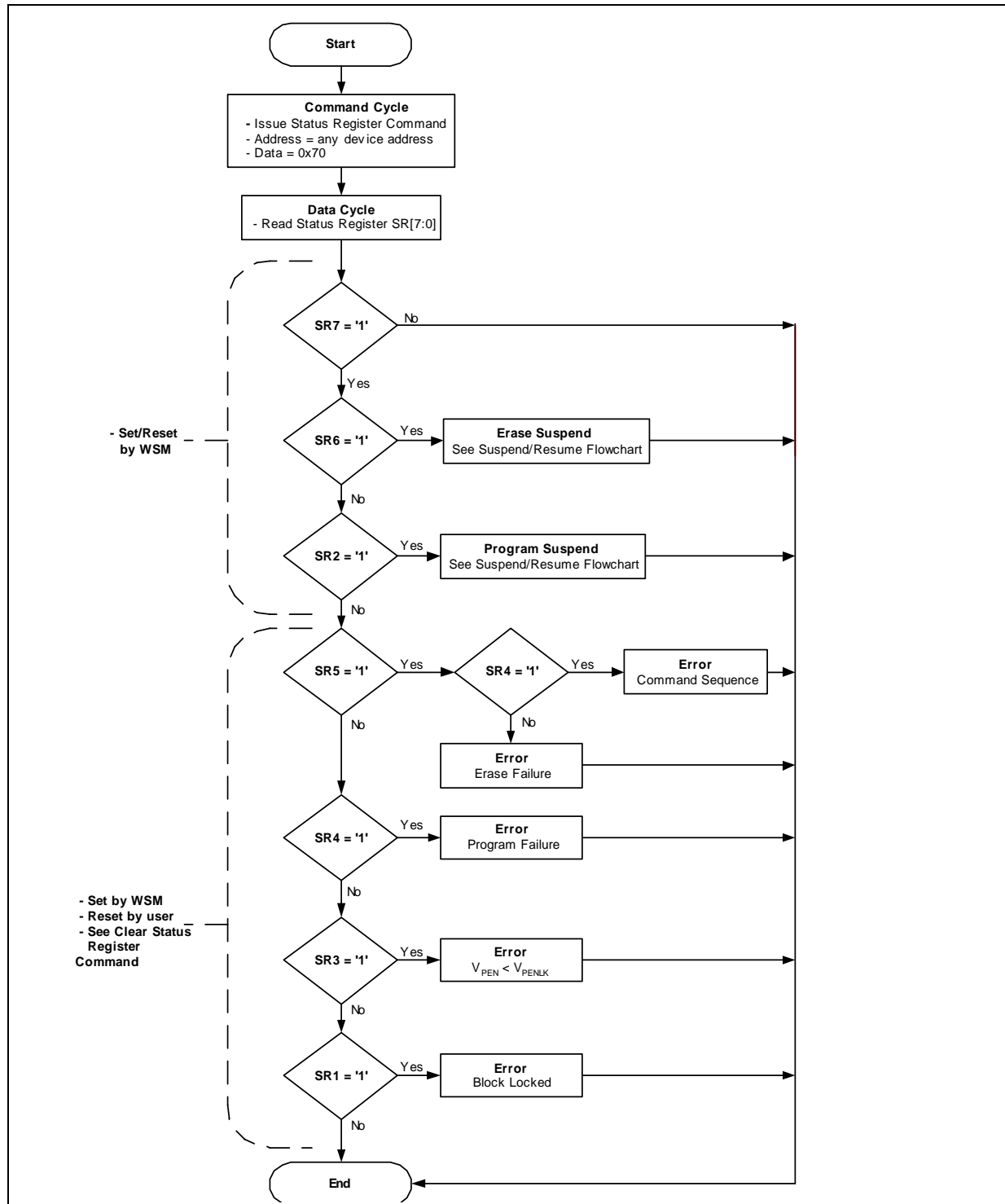

Figure 18: Byte/Word Program Flowchart

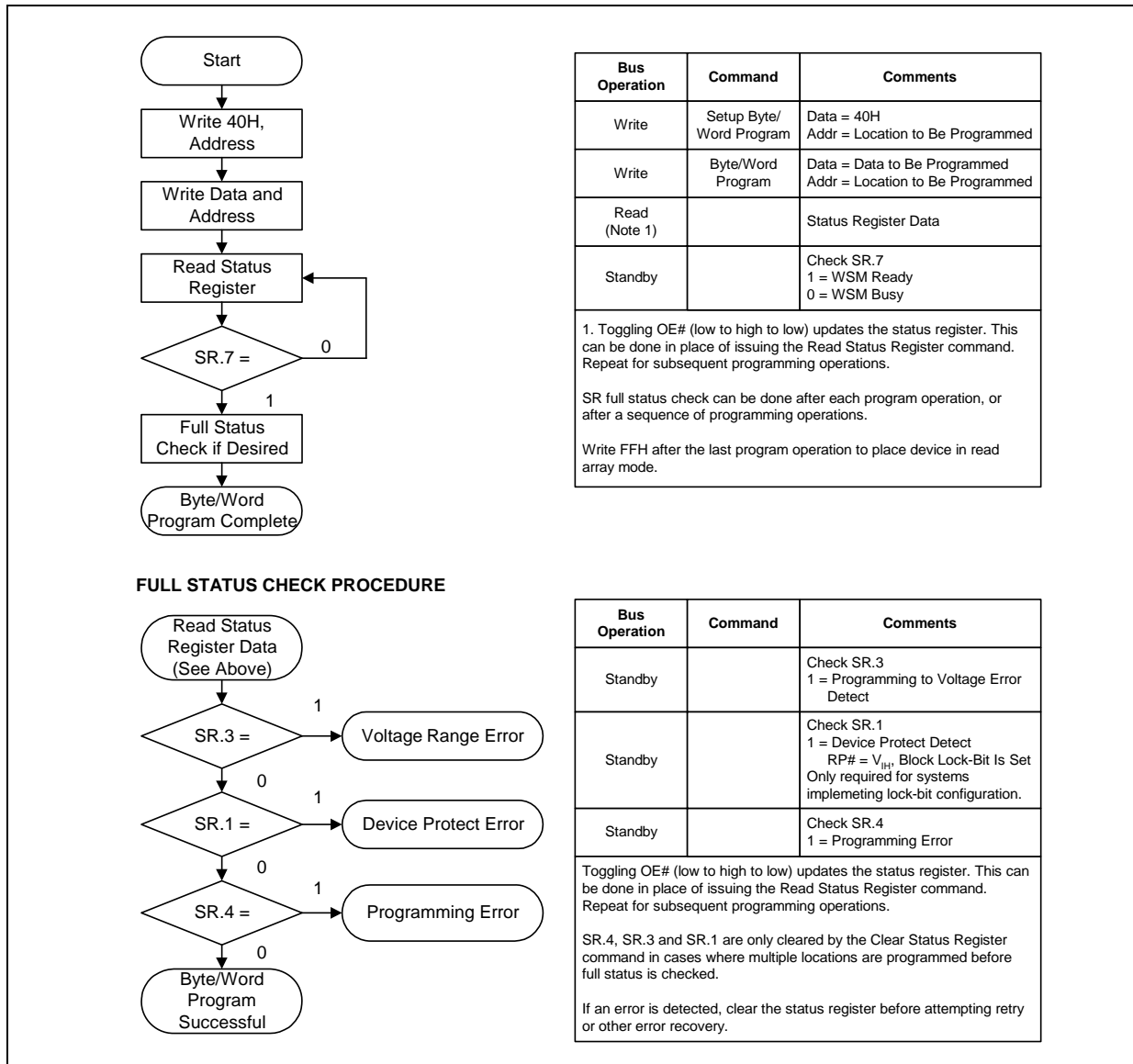

Figure 19: Program Suspend/Resume Flowchart

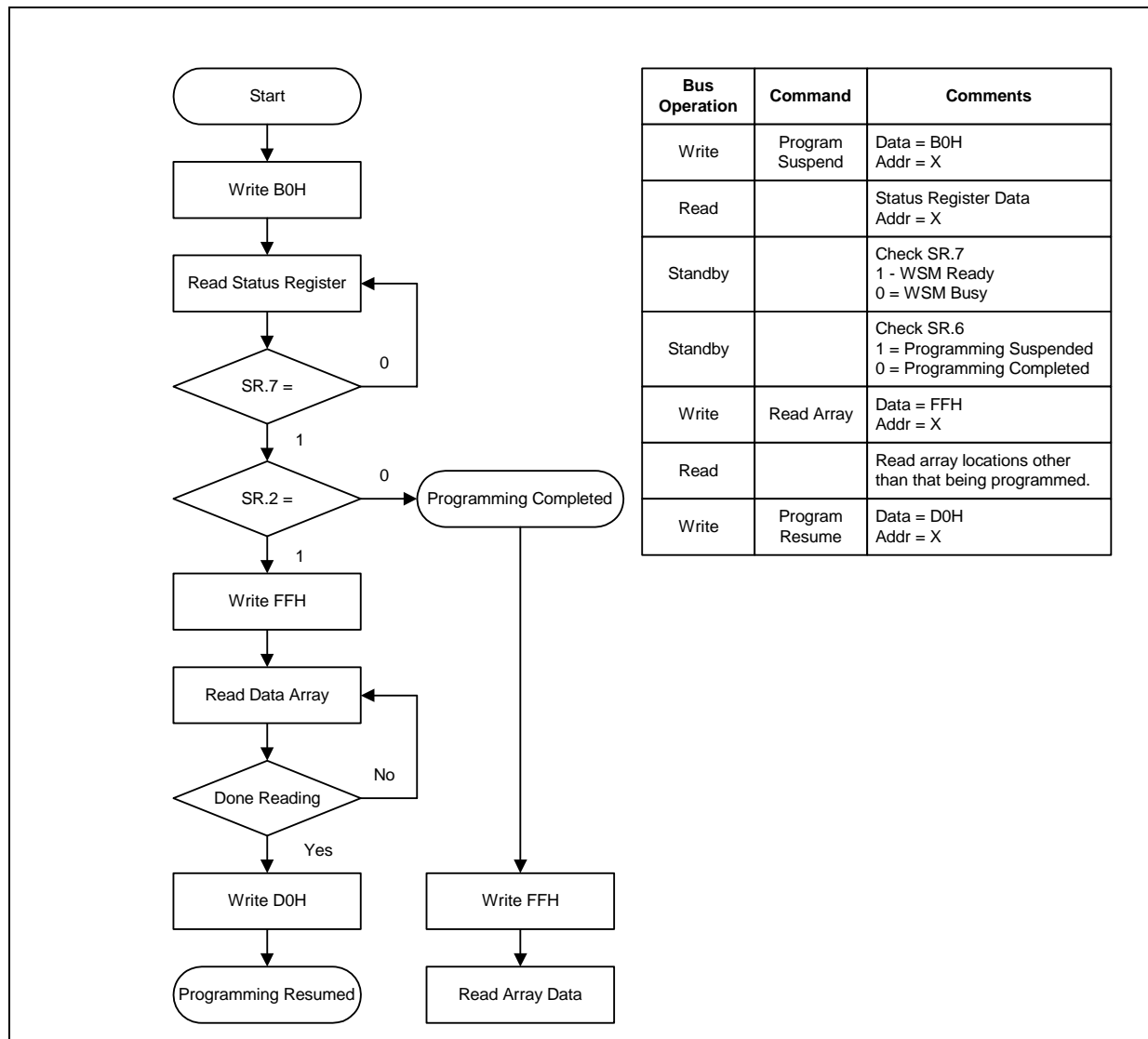

Figure 20: Block Erase Flowchart

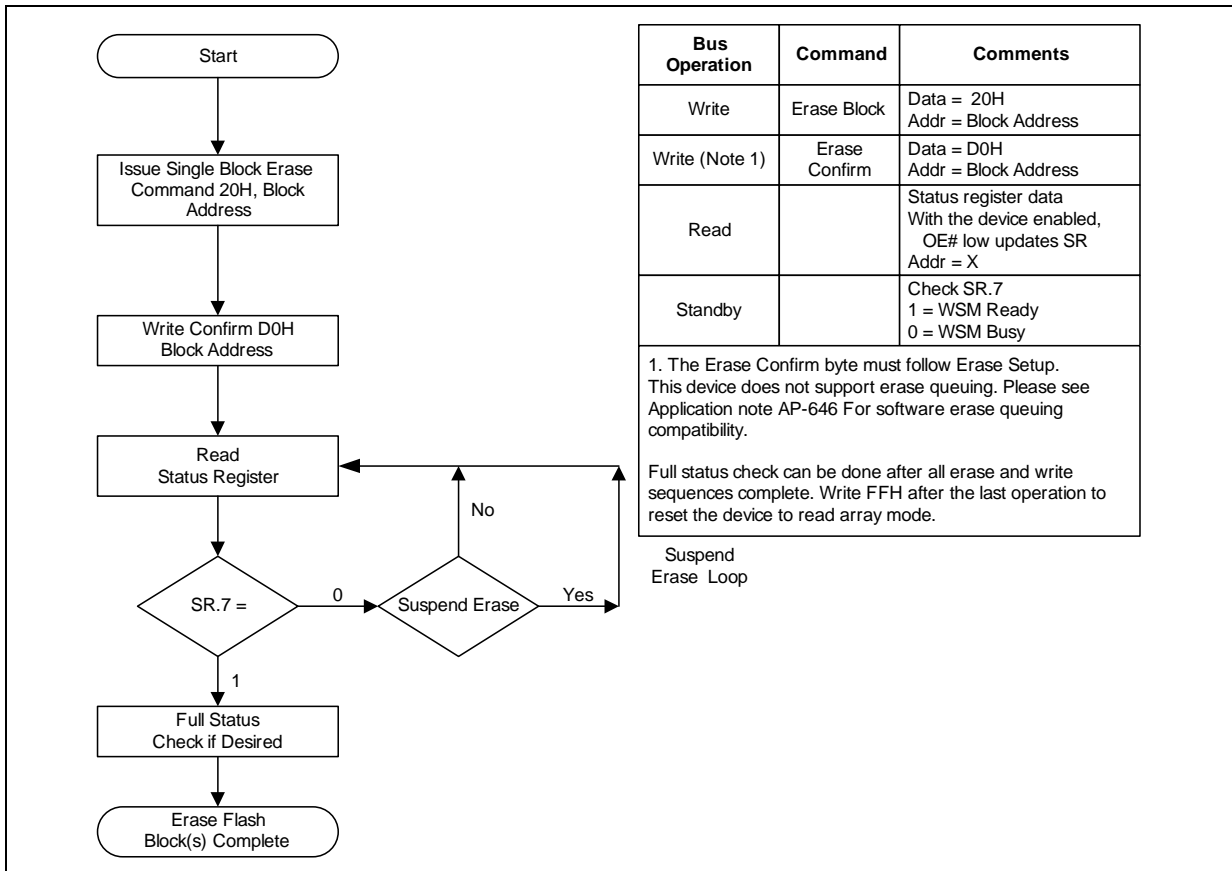

Figure 21: Block Erase Suspend/Resume Flowchart

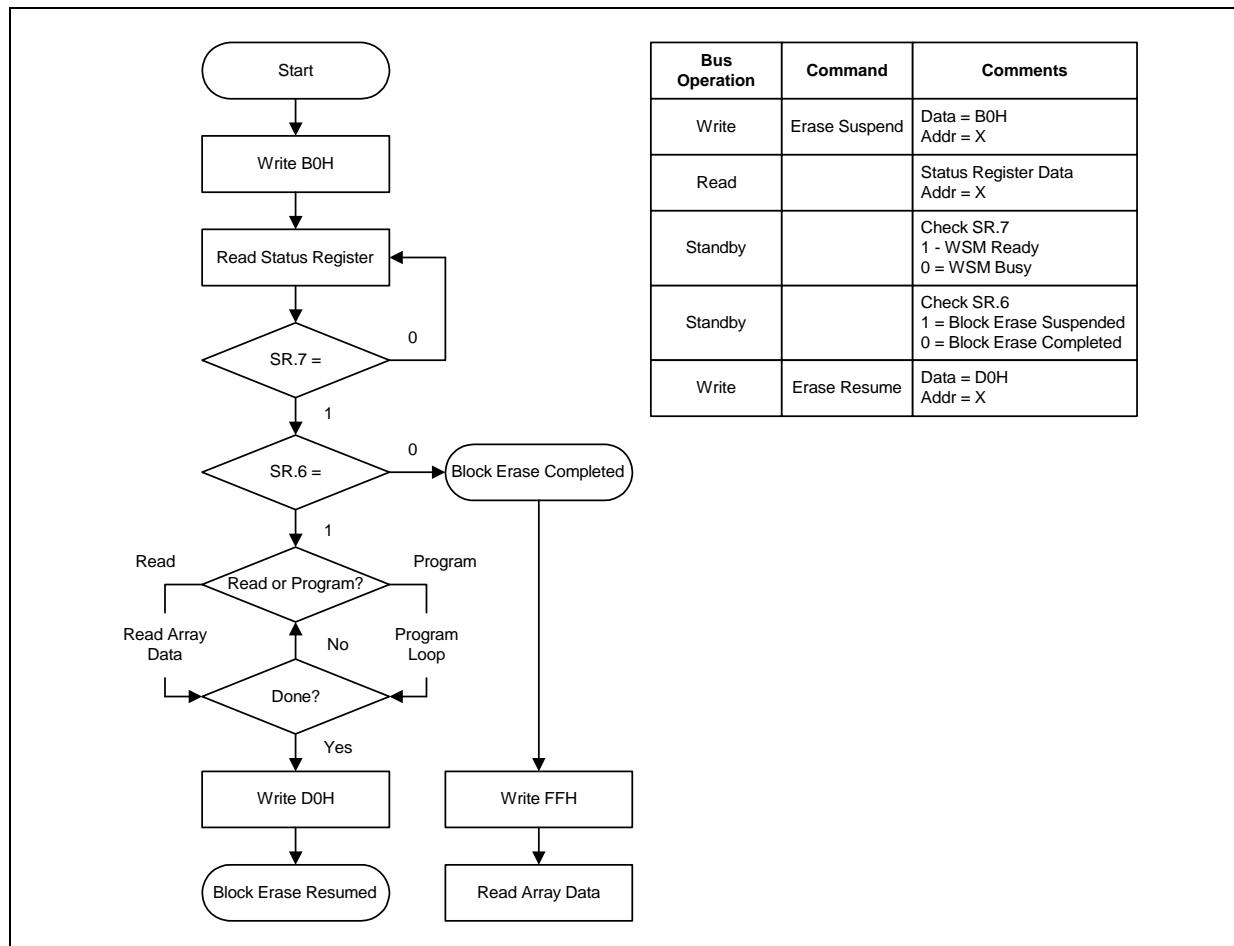

Figure 22: Set Block Lock-Bit Flowchart

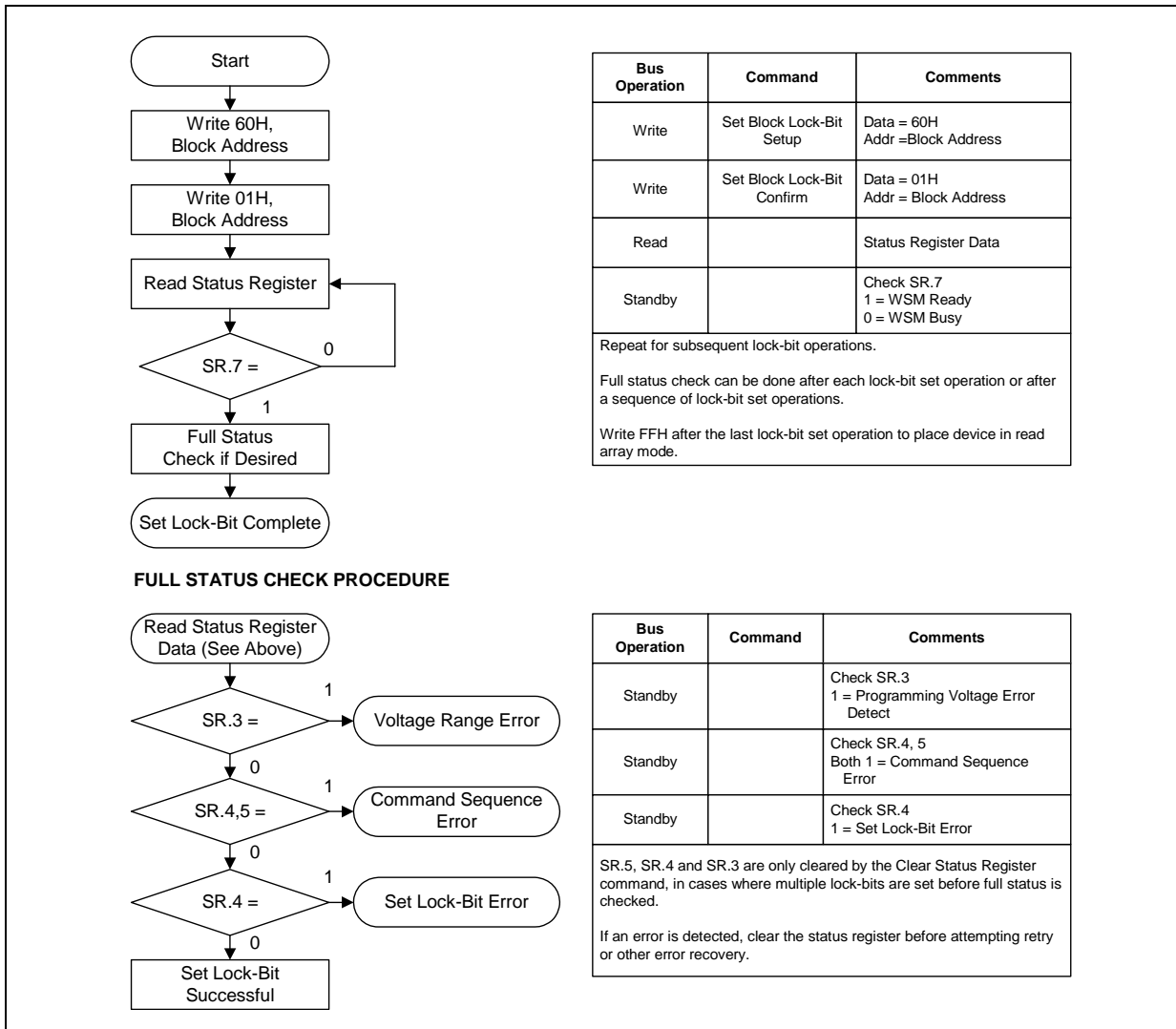

Figure 23: Clear Lock-Bit Flowchart

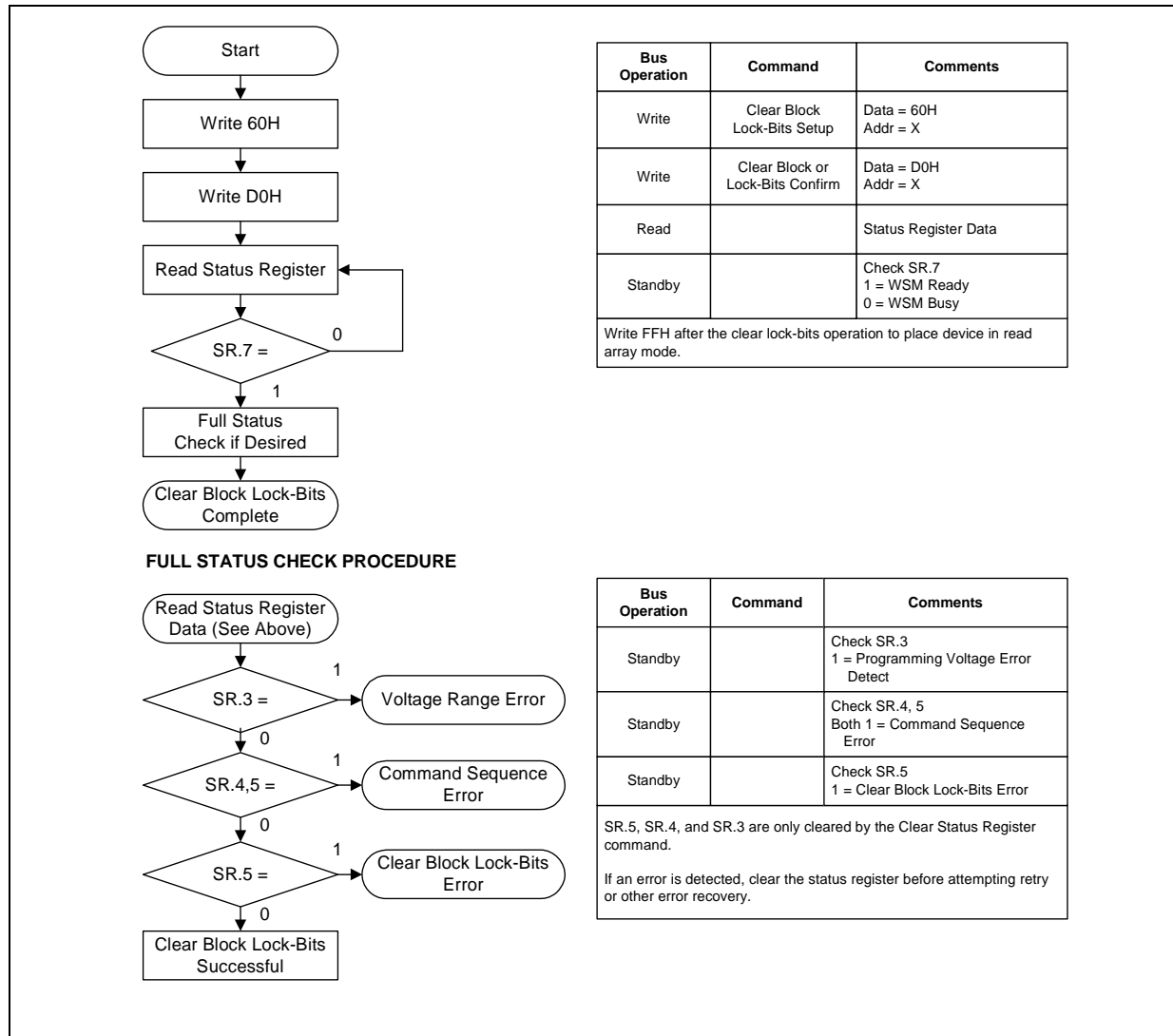
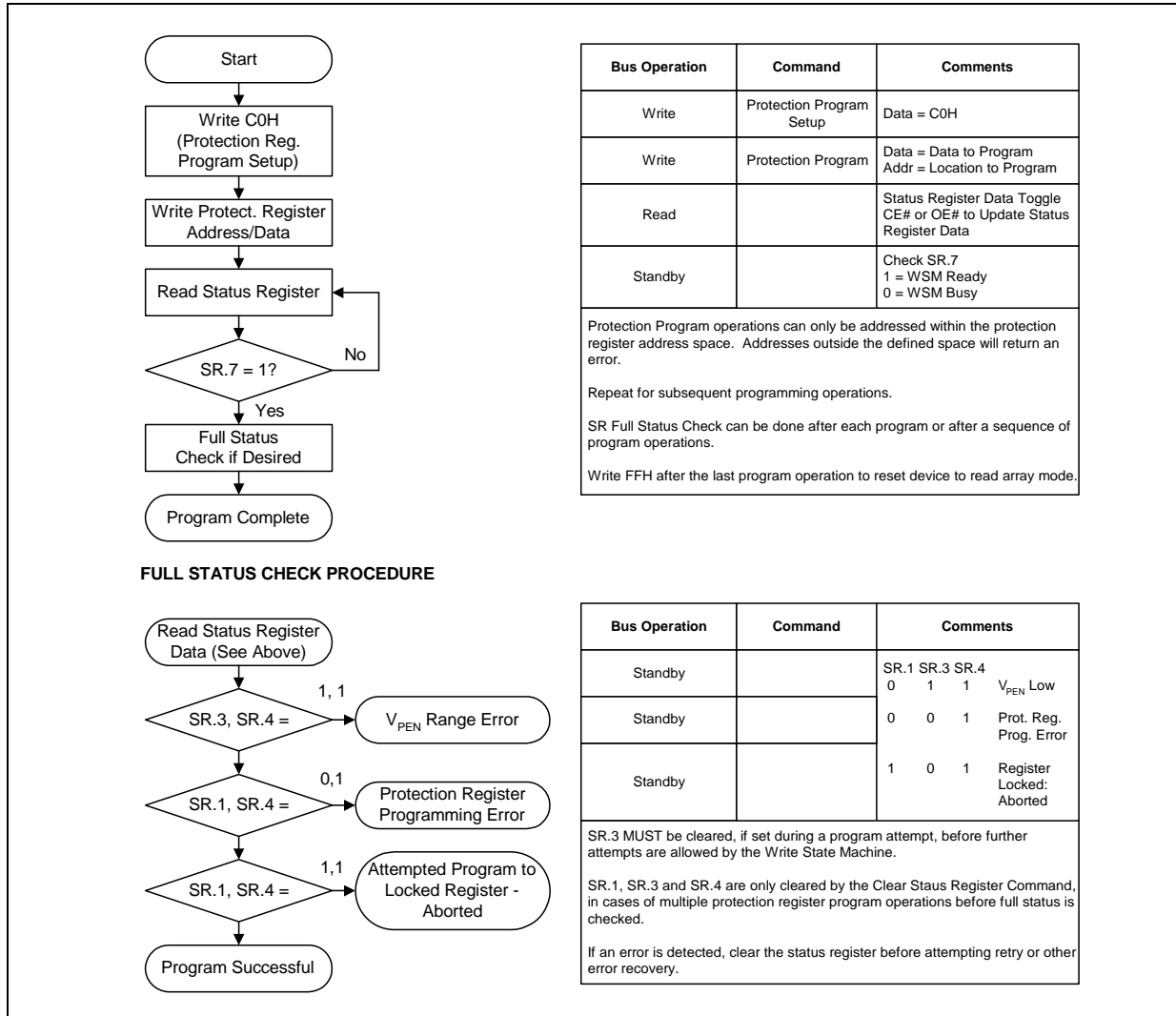

Figure 24: Protection Register Programming Flowchart



## 13.0 Common Flash Interface

The CFI specification outlines device and host system software interrogation handshake which allows specific vendor-specified software algorithms to be used for entire families of devices. This allows device independent, JEDEC ID-independent, and forward- and backward-compatible software support for the specified flash device families. It allows flash vendors to standardize their existing interfaces for long-term compatibility.

This section defines the data structure or “database” returned by the (CFI) Query command. System software should parse this structure to gain critical information such as block size, density, x8/x16, and electrical specifications. Once this information has been obtained, the software will know which command sets to use to enable flash writes, block erases, and otherwise control the flash component. The Query is part of an overall specification for multiple command set and control interface descriptions called CFI.

### 13.1 Query Structure Output

The Query “database” allows system software to gain information for controlling the flash component. This section describes the device’s CFI-compliant interface that allows the host system to access Query data.

Query data are always presented on the lowest-order data outputs (D[7:0]) only. The numerical offset value is the address relative to the maximum bus width supported by the device. On this family of devices, the Query table device starting address is a 10h, which is a word address for x16 devices.

For a word-wide (x16) device, the first two bytes of the Query structure, “Q” and “R” in ASCII, appear on the low byte at word addresses 10h and 11h. This CFI-compliant device outputs 00h data on upper bytes. Thus, the device outputs ASCII “Q” in the low byte (D[7:0]) and 00h in the high byte (D[15:8]).

At Query addresses containing two or more bytes of information, the least significant data byte is presented at the lower address, and the most significant data byte is presented at the higher address.

In all of the following tables, addresses and data are represented in hexadecimal notation, so the “h” suffix has been dropped. In addition, since the upper byte of word-wide devices is always “00h,” the leading “00” has been dropped from the table notation and only the lower byte value is shown. Any x16 device outputs can be assumed to have 00h on the upper byte in this mode.

**Table 35: Summary of Query Structure Output as a Function of Device and Mode**

Device Type/ Mode	Query start location in maximum device bus width addresses	Query data with maximum device bus width addressing			Query data with byte addressing		
		Hex Offset	Hex Code	ASCII Value	Hex Offset	Hex Code	ASCII Value
x16 device	10h	10:	0051	“Q”	20:	51	“Q”
x16 mode		11:	0052	“R”	21:	00	“Null”
		12:	0059	“Y”	22:	52	“R”
x16 device					20:	51	“Q”

**Table 35: Summary of Query Structure Output as a Function of Device and Mode**

Device Type/ Mode	Query start location in maximum device bus width addresses	Query data with maximum device bus width addressing			Query data with byte addressing		
		Hex Offset	Hex Code	ASCII Value	Hex Offset	Hex Code	ASCII Value
x8 mode	N/A <sup>(1)</sup>		N/A <sup>(1)</sup>		21:	51	"Q"
					22:	52	"R"

**Note:**

- The system must drive the lowest order addresses to access all the device's array data when the device is configured in x8 mode. Therefore, word addressing, where these lower addresses are not toggled by the system, is "Not Applicable" for x8-configured devices.

**Table 36: Example of Query Structure Output of a x16- and x8-Capable Device**

Word Addressing			Byte Addressing		
Offset	Hex Code	Value	Offset	Hex Code	Value
A <sub>15</sub> –A <sub>0</sub>	D <sub>15</sub> –D <sub>0</sub>		A <sub>7</sub> –A <sub>0</sub>	D <sub>7</sub> –D <sub>0</sub>	
0010h	0051	"Q"	20h	51	"Q"
0011h	0052	"R"	21h	51	"Q"
0012h	0059	"Y"	22h	52	"R"
0013h	P_ID <sub>LO</sub>	PrVendor	23h	52	"R"
0014h	P_ID <sub>HI</sub>	ID #	24h	59	"Y"
0015h	P <sub>LO</sub>	PrVendor	25h	59	"Y"
0016h	P <sub>HI</sub>	TblAdr	26h	P_ID <sub>LO</sub>	PrVendor
0017h	A_ID <sub>LO</sub>	AltVendor	27h	P_ID <sub>LO</sub>	PrVendor
0018h	A_ID <sub>HI</sub>	ID #	28h	P_ID <sub>HI</sub>	ID #
...	...	...	...	...	...

## 13.2 Query Structure Overview

The Query command causes the flash component to display the Common Flash Interface (CFI) Query structure or "database." The structure sub-sections and address locations are summarized below. See *AP-646 Common Flash Interface (CFI) and Command Sets* (order number 292204) for a full description of CFI.

The following sections describe the Query structure sub-sections in detail.

**Table 37: Query Structure**

Offset	Sub-Section Name	Description	Notes
00h	Identification Code	Manufacturer Code	1
01h	Identification Code	Device Code	1
(BA+2)h <sup>(2)</sup>	Block Status Register	Block-Specific Information	1,2
04-0Fh	Reserved	Reserved for Vendor-Specific Information	1
10h	CFI Query Identification String	Reserved for Vendor-Specific Information	1
1Bh	System Interface Information	Command Set ID and Vendor Data Offset	1

**Table 37: Query Structure**

Offset	Sub-Section Name	Description	Notes
27h	Device Geometry Definition	Flash Device Layout	1
P <sup>(3)</sup>	Primary Numonyx-Specific Extended Query Table	Vendor-Defined Additional Information Specific to the Primary Vendor Algorithm	1,3

**Notes:**

1. Refer to the Query Structure Output section and offset 28h for the detailed definition of offset address as a function of device bus width and mode.
2. BA = Block Address beginning location (i.e., 02000h is block 2's beginning location when the block size is 128 KB).
3. Offset 15 defines "P" which points to the *Primary Numonyx-Specific Extended Query Table*.

### 13.3 Block Status Register

The Block Status Register indicates whether an erase operation completed successfully or whether a given block is locked or can be accessed for flash program/erase operations.

**Table 38: Block Status Register**

Offset	Length	Description	Address	Value
(BA+2)h <sup>(1)</sup>	1	Block Lock Status Register	BA+2:	--00 or --01
		BSR.0 Block Lock Status 0 = Unlocked 1 = Locked	BA+2:	(bit 0): 0 or 1
		BSR 1–15: <i>Reserved for Future Use</i>	BA+2:	(bit 1–15): 0

**Note:**

1. BA = The beginning location of a Block Address (i.e., 010000h is block 1's (64-KW block) beginning location in word mode).

### 13.4 CFI Query Identification String

The CFI Query Identification String provides verification that the component supports the Common Flash Interface specification. It also indicates the specification version and supported vendor-specified command set(s).

**Table 39: CFI Identification**

Offset	Length	Description	Add.	Hex Code	Value
10h	3	Query-unique ASCII string "QRY"	10:	--51	"Q"
			11:	--52	"R"
			12:	--59	"Y"
13h	2	Primary vendor command set and control interface ID code. 16-bit ID code for vendor-specified algorithms	13:	--01	
			14:	--00	
15h	2	Extended Query Table primary algorithm address	15:	--31	
			16:	--00	
17h	2	Alternate vendor command set and control interface ID code. 0000h means no second vendor-specified algorithm exists	17:	--00	
			18:	--00	
19h	2	Secondary algorithm Extended Query Table address. 0000h means none exists	19:	--00	
			1A:	--00	

## 13.5 System Interface Information

The following device information can optimize system interface software.

**Table 40: System Interface Information**

Offset	Length	Description	Add.	Hex Code	Value
1Bh	1	V <sub>CC</sub> logic supply minimum program/erase voltage bits 0–3 BCD 100 mV bits 4–7 BCD volts	1B:	--27	2.7 V
1Ch	1	V <sub>CC</sub> logic supply maximum program/erase voltage bits 0–3 BCD 100 mV bits 4–7 BCD volts	1C:	--36	3.6 V
1Dh	1	V <sub>pp</sub> [programming] supply minimum program/erase voltage bits 0–3 BCD 100 mV bits 4–7 HEX volts	1D:	--00	0.0 V
1Eh	1	V <sub>pp</sub> [programming] supply maximum program/erase voltage bits 0–3 BCD 100 mV bits 4–7 HEX volts	1E:	--00	0.0 V
1Fh	1	"n" such that typical single word program time-out = 2 <sup>n</sup> μs	1F:	--06	64 μs
20h	1	"n" such that typical max. buffer write time-out = 2 <sup>n</sup> μs	20:	--07 <sup>1</sup>	128 μs <sup>1</sup>
21h	1	"n" such that typical block erase time-out = 2 <sup>n</sup> ms	21:	--0A	1 s
22h	1	"n" such that typical full chip erase time-out = 2 <sup>n</sup> ms	22:	--00	NA
23h	1	"n" such that maximum word program time-out = 2 <sup>n</sup> times typical	23:	--02	256 μs
24h	1	"n" such that maximum buffer write time-out = 2 <sup>n</sup> times typical	24:	--03	1024μs
25h	1	"n" such that maximum block erase time-out = 2 <sup>n</sup> times typical	25:	--02	4 s
26h	1	"n" such that maximum chip erase time-out = 2 <sup>n</sup> times typical	26:	--00	NA
<b>Notes:</b>					
1. The value is 32 Bytes buffer write typical time out					

## 13.6 Device Geometry Definition

This field provides critical details of the flash device geometry.

**Table 41: Device Geometry Definition (Sheet 1 of 2)**

Offset	Length	Description	Code See Table Below		
27h	1	"n" such that device size = 2 <sup>n</sup> in number of bytes	27:		
28h	2	Flash device interface: <u>x8_async</u> <u>x16_async</u> <u>x8/x16_async</u>  28:00,29:00 28:01,29:00 28:02,29:00	28:	--02	x8/ x16
			29:	--00	
2Ah	2	"n" such that maximum number of bytes in write buffer = 2 <sup>n</sup>	2A:	--05 <sup>1</sup>	32 <sup>1</sup>
			2B:	--00	
2Ch	1	Number of erase block regions within device: 1. x = 0 means no erase blocking; the device erases in "bulk" 2. x specifies the number of device or partition regions with one or more contiguous same-size erase blocks 3. Symmetrically blocked partitions have one blocking region 4. Partition size = (total blocks) x (individual block size)	2C:	--01	1
<b>Notes:</b>					
1. The value is 32 Bytes buffer write typical time out					

**Table 41: Device Geometry Definition (Sheet 2 of 2)**

Offset	Length	Description	Code See Table Below	
2Dh	4	Erase Block Region 1 Information bits 0–15 = y, y+1 = number of identical-size erase blocks bits 16–31 = z, region erase block(s) size are z x 256 bytes	2D:	
			2E:	
			2F:	
			30:	
<b>Notes:</b> 1. Compatible with J3 130nm device (32 bytes). J3 65 nm SBC device supports up to maximum 256 words (x16 mode)/ 256 bytes (x8 mode) buffer write.				

**Table 42: Device Geometry: Address Codes**

Address	32 Mbit	64 Mbit	128 Mbit
27:	--16	--17	--18
28:	--02	--02	--02
29:	--00	--00	--00
2A:	--05	--05	--05
2B:	--00	--00	--00
2C:	--01	--01	--01
2D:	--1F	--3F	--7F
2E:	--00	--00	--00
2F:	--00	--00	--00
30:	--02	--02	--02

### 13.7 Primary-Vendor Specific Extended Query Table

Certain flash features and commands are optional. The *Primary Vendor-Specific Extended Query* table specifies this and other similar information.

**Table 43: Primary Vendor-Specific Extended Query (Sheet 1 of 2)**

Offset <sup>(1)</sup> P = 31h	Length	Description (Optional Flash Features and Commands)	Add.	Hex Code	Value
(P+0)h	3	Primary extended query table	31:	--50	"P"
(P+1)h		Unique ASCII string "PRI"	32:	--52	"R"
(P+2)h			33:	--49	"I"
(P+3)h	1	Major version number, ASCII	34:	--31	"1"
(P+4)h	1	Minor version number, ASCII	35:	--31	"1"

**Table 43: Primary Vendor-Specific Extended Query (Sheet 2 of 2)**

Offset <sup>(1)</sup> P = 31h	Length	Description (Optional Flash Features and Commands)	Add.	Hex Code	Value
(P+5)h (P+6)h (P+7)h (P+8)h	4	Optional feature and command support (1=yes, 0=no) Undefined bits are "0." If bit 31 is "1" then another 31 bit field of optional features follows at the end of the bit-30 field.	36:	--CE	
			37:	--00	
			38:	--00	
			39:	--00	
		bit 0 Chip erase supported	bit 0 = 0	No	
		bit 1 Suspend erase supported	bit 1 = 1	Yes	
		bit 2 Suspend program supported	bit 2 = 1	Yes	
		bit 3 Legacy lock/unlock supported	bit 3 = 1	Yes	
		bit 4 Queued erase supported	bit 4 = 0	No	
bit 5 Instant Individual block locking supported	bit 5 = 0	No			
bit 6 Protection bits supported	bit 6 = 1	Yes			
bit 7 Page-mode read supported	bit 7 = 1	Yes			
bit 8 Synchronous read supported	bit 8 = 0	No			
		bit9 Simultaneous Operation Supported	bit 9 = 0	No	
		bit 30 CFI Link(s) to follow (32, 64, 128 Mb)	bit 30 = 0	No	
		bit 31 Another "Optional Feature" field to follow	bit 31 = 0	No	
(P+9)h	1	Supported functions after suspend: read Array, Status, Query Other supported operations are: <i>bits 1–7 reserved; undefined bits are "0"</i>	3A:	--01	
		bit 0 Program supported after erase suspend	bit 0 = 1	Yes	
(P+A)h (P+B)h	2	Block Status Register mask bits 2–15 are Reserved; undefined bits are "0"	3B:	--01	
		bit 0 Block Lock-Bit Status register active	3C:	--00	
		bit 1 Block Lock-Down Bit Status active	bit 0 = 1	Yes	
			bit 1 = 0	No	
(P+C)h	1	V <sub>CC</sub> logic supply highest performance program/erase voltage bits 0–3 BCD value in 100 mV bits 4–7 BCD value in volts	3D:	--33	3.3 V
(P+D)h	1	V <sub>PP</sub> optimum program/erase supply voltage bits 0–3 BCD value in 100 mV bits 4–7 HEX value in volts	3E:	--00	0.0 V

**Note:**

- Setting this bit, will lead to the extension of the CFI table.

**Table 44: Protection Register Information**

Offset <sup>(1)</sup> P = 31h	Length	Description (Optional Flash Features and Commands)	Add.	Hex Code	Value
(P+E)h	1	Number of Protection register fields in JEDEC ID space. "00h," indicates that 256 protection bytes are available	3F:	--01	01
(P+F)h (P+10)h (P+11)h (P+12)h	4	Protection Field 1: Protection Description This field describes user-available One Time Programmable (OTP) protection register bytes. Some are pre-programmed with device-unique serial numbers. Others are user-programmable. Bits 0-15 point to the protection register lock byte, the section's first byte. The following bytes are factory pre-programmed and user-programmable. bits 0-7 = Lock/bytes JEDEC-plane physical low address bits 8-15 = Lock/bytes JEDEC-plane physical high address bits 16-23 = "n" such that 2 <sup>n</sup> = factory pre-programmed bytes bits 24-31 = "n" such that 2 <sup>n</sup> = user-programmable bytes	40: 41: 42: 43:	--80 --00 --03 --03	80h 00h 8bytes 8bytes

**Note:**

1. The variable P is a pointer which is defined at CFI offset 15h.

**Table 45: Burst Read Information**

Offset <sup>(1)</sup> P = 31h	Length	Description (Optional Flash Features and Commands)	Add.	Hex Code	Value
(P+13)h	1	Page Mode Read capability bits 0-7 = "n" such that 2 <sup>n</sup> HEX value represents the number of read-page bytes. See offset 28h for device word width to determine page-mode data output width. 00h indicates no read page buffer.	44:	--04	16 byte
(P+14)h	1	Number of synchronous mode read configuration fields that follow. 00h indicates no burst capability.	45:	--00	0
(P+15)h	1	Synchronous Mode Read Capability Configuration 1 Bits 3-7 = Reserved bits 0-2 = "n" such that 2 <sup>n+1</sup> HEX value represents the maximum number of continuous synchronous burst reads when the device is configured for its maximum word width. A value of 07h indicates that the device is capable of continuous linear bursts until that will output data until the internal burst counter reaches the end of the device's burstable address space. This field's 3-bit value can be written directly to the Read Configuration Register Bits 0-2 if the device is configured for its maximum word width. See offset 1Fh for word width to determine the burst data output width.	46:	--00	n/a
(P+16)h	1	Synchronous Mode Read Capability Configuration 2	47:	--00	n/a
(P+45)h	1	J3C mark for VIL fix for customers	76:	--01	01

**Note:**

1. The variable P is a pointer which is defined at CFI offset 15h.

## Appendix A Additional Information

Order Number	Document/Tool
316577	Numonyx® Embedded Flash Memory (J3 v D); 28F256J3D, 28F128J3D, 28F640J3D, 28F320J3D Specification Update
298136	Numonyx® Persistent Storage Manager (PSM) User's Guide Software Manual
292204	AP-646 Common Flash Interface (CFI) and Command Sets
319942	Numonyx® Embedded Flash Memory (J3-65nm_256-Mbit_MLC Datasheet)

**Note:** Contact your local Numonyx or distribution sales office or visit the Numonyx home page <http://www.numonyx.com> for technical documentation, tools, or the most current information on Numonyx® Embedded Flash Memory (J3 65 nm) Single Bit per Cell (SBC) .

## Appendix B Ordering Information

Figure 25: Decoder for 32-, 64-, 128-Mbit

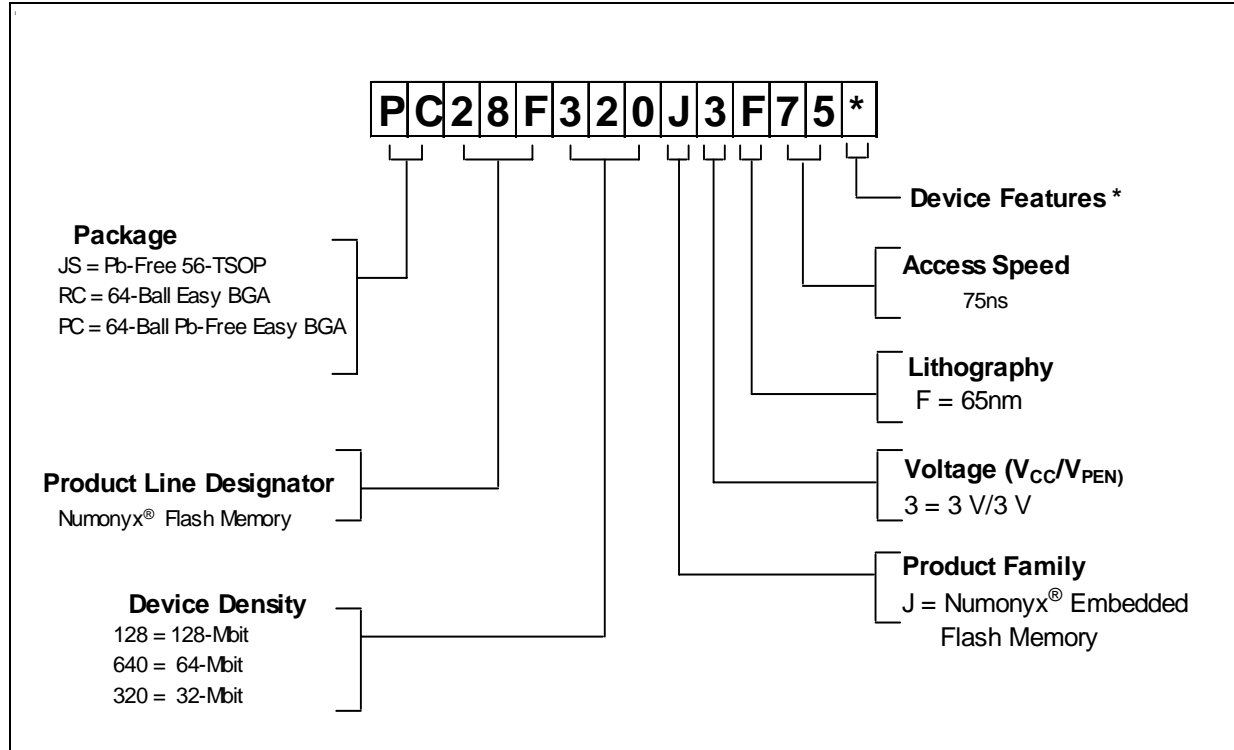

*Note:* The last digit is randomly assigned to cover packing media and/or features or other specific configuration.

Table 46: Valid Combinations

32-Mbit	64-Mbit	128-Mbit
JS28F320J3F75*	JS28F640J3F75*	JS28F128J3F75*
RC28F320J3F75*	RC28F640J3F75*	RC28F128J3F75*
PC28F320J3F75*	PC28F640J3F75*	PC28F128J3F75*

*Note:* For further information on ordering products or for product part numbers, go to: <http://www.numonyx.com/en-US/MemoryProducts/Pages/PartNumberLookup.aspx>.

## **Numonyx® Embedded Flash Memory (J3 65 nm) Single Bit per Cell (SBC)**

8000 S. Federal Way, P.O. Box 6, Boise, ID 83707-0006, Tel: 208-368-3900

[www.micron.com/productsupport](http://www.micron.com/productsupport) Customer Comment Line: 800-932-4992

Micron and the Micron logo are trademarks of Micron Technology, Inc.

All other trademarks are the property of their respective owners.

This data sheet contains minimum and maximum limits specified over the power supply and temperature range set forth herein.

Although considered final, these specifications are subject to change, as further product development and data characterization sometimes occur.