

Dual line programmable transient voltage suppressor for SLIC protection

Datasheet - production data

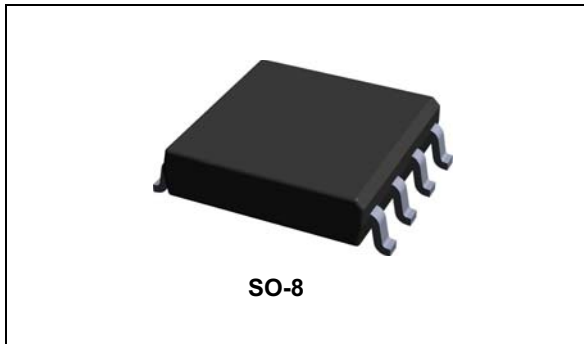

Description

This device has been especially designed to protect 2 new high voltage, as well as classical SLICs, against transient overvoltages.

Positive overvoltages are clamped by 2 diodes. Negative surges are suppressed by 2 thyristors, their breakdown voltage being referenced to $-V_{BAT}$ through the gate. Separated gates allow the SLICs to be supplied by two different voltages.

Features

- Dual line programmable transient voltage suppressor with separated gates
- Wide negative firing voltage range: $V_{Gn} = -175\text{ V max.}$
- Low dynamic switching voltages: V_{FP} and V_{DGL}
- Low gate triggering current: $I_{GT} = 5\text{ mA max}$
- Peak pulse current: $I_{PP} = 40\text{ A (5/310 }\mu\text{s)}$
- Holding current: $I_H = 150\text{ mA min.}$

Benefits

- A Trisil™ is not subject to ageing and provides a fail safe mode in short circuit for a better protection.
- Trisils are used to help equipment to meet various standards such as UL1950, IEC 60950 / CSA C22.2, UL1459 and TIA-968-A (formerly FCC part 68).
- Trisils have UL94 V0 resin approved (Trisils are UL497B approved - file: E136224).

Figure 1. Functional diagram

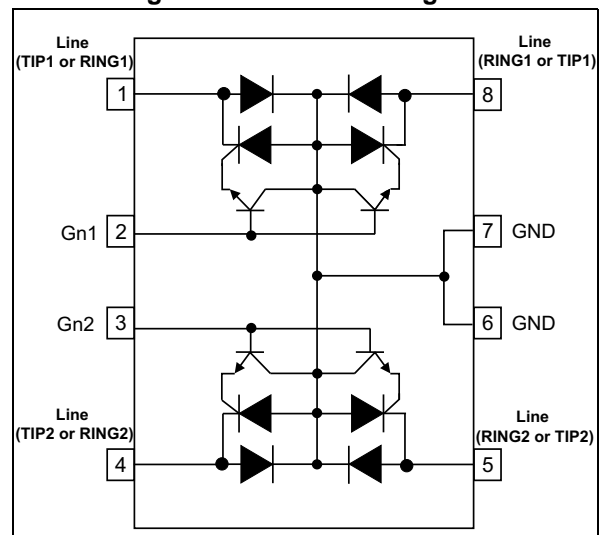

TM: Trisil is a trademark of STMicroelectronics

1 Characteristics

Table 1. Standards compliance

Standard	Peak surge voltage (V)	Voltage waveform	Required peak current (A)	Current waveform	Minimum serial resistor to meet standard (Ω)
GR-1089 Core First level	2500	2/10 μ s	500	2/10 μ s	23
	1000	10/1000 μ s	100	10/1000 μ s	30
GR-1089 Core Second level	5000	2/10 μ s	500	2/10 μ s	46
GR-1089 Core Intra-building	1500	2/10 μ s	100	2/10 μ s	2
ITU-T-K20/K21	6000	10/700 μ s	150	5/310 μ s	110
	1500		37.5		0
ITU-T-K20 (IEC 61000-4-2)	8000	1/60 ns	ESD contact discharge		0
	15000		ESD air discharge		0
IEC 61000-4-5	4000	10/700 μ s	100	5/310 μ s	60
	4000	1.2/50 μ s	100	8/20 μ s	27
TIA-968-A, lightning surge type A	1500	10/160 μ s	200	10/160 μ s	36
	800	10/560 μ s	100	10/560 μ s	24
TIA-968-A, lightning surge type B	1000	9/720 μ s	25	5/320 μ s	0

Table 2. Thermal resistances

Symbol	Parameter	Value	Unit
$R_{th(j-a)}$	Junction to ambient	170	$^{\circ}\text{C}/\text{W}$

Table 3. Absolute ratings (0 °C < T_j < 70 °C, unless otherwise specified)

Symbol	Parameter	Value	Unit	
I _{PP}	Peak pulse current ⁽¹⁾	10/1000 μs	25	
		8/20 μs	60	
		10/560 μs	25	
		5/310 μs	40	
		10/160 μs	35	
		1/20 μs	60	
		2/10 μs	90	
I _{TSM}	Non repetitive surge peak on-state current (50 Hz sinusoidal) ⁽¹⁾	t = 0.2 s	5	
		t = 1 s	3.5	
		t = 2 s	3	
		t = 15 mn	1.3	
V _{Gn}	Negative battery voltage range	-40 °C < T _{amb} < +85 °C	-175	V
T _{stg}	Storage temperature range		-55 to +150	°C
T _j	Operating junction temperature range		-55 to +150	
T _L	Maximum lead temperature for soldering during 10 s.		260	°C

1. The rated current values may be applied either to the Ring to GND or to the Tip to GND terminal pairs. Additionally, the four terminal pairs may have their rated current values applied simultaneously (in this case the GND terminal current will be four times the rated current value of an individual terminal pair)

Figure 2. Electrical characteristics (definitions)

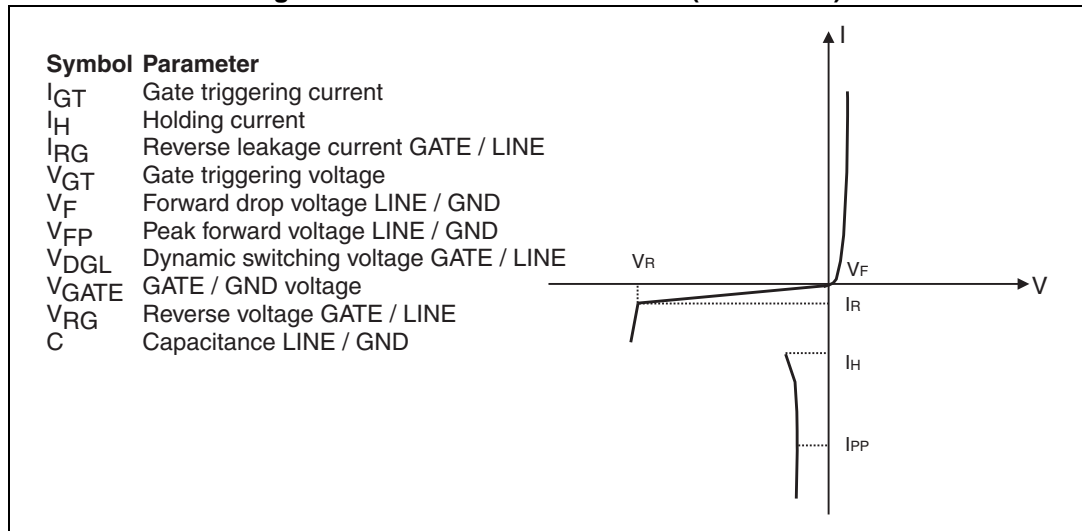

Figure 3. Pulse waveform

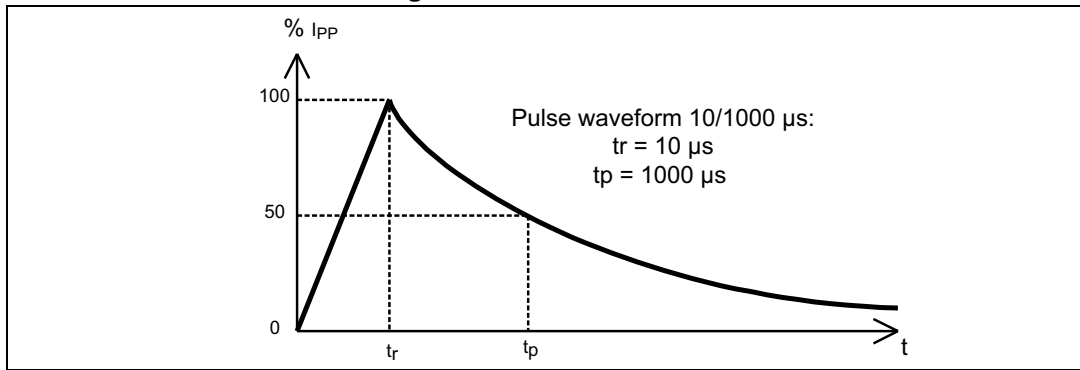

Table 4. Parameters ($T_j = 25^\circ C$ unless otherwise specified)

Symbol	Test conditions	Min.	Typ.	Max.	Unit
I_{GT}	$V_{LINE} = -48 V$	0.05		5	mA
I_H	$V_{Gn} = -48 V$	150			mA
V_{GT}	at I_{GT}			2.5	V
I_{RG}	$V_{RG} = -175 V$ $V_{RG} = -175 V$			5 50	μA
	$T_j = 25^\circ C$ $T_j = 85^\circ C$				
$V_{DGL}^{(1)}$	$V_{Gn} = -48 V$ 10/700 μs 1.5 kV $R_S = 0 \Omega$ $I_{PP} = 37.5 A$			5	V
V_F	$I_F = 1 A$ $t = 500 \mu s$			2	V
$V_{FP}^{(1)}$	10/700 μs 1.5 kV $R_S = 0 \Omega$ $I_{PP} = 37.5 A$			8	V
I_R	$V_{Gn / LINE} = -1V, V_{LINE} = -175 V$ $V_{Gn / LINE} = -1V, V_{LINE} = -175 V$			5 50	μA
	$T_j = 25^\circ C$ $T_j = 85^\circ C$				
C	$V_{LINE} = -50 V, V_{RMS} = 1 V, F = 1 MHz$ $V_{LINE} = -2 V, V_{RMS} = 1 V, F = 1 MHz$		18 35		pF

1. The oscillations with a time duration lower than 50 ns are not taken into account.

Table 5. Recommended gate capacitance

Symbol	Component	Min.	Typ.	Max.	Unit
C_G	Gate decoupling capacitance	100	220		nF

2 Technical information

The LCDP1521S is particularly optimized for the new telecom applications such as the fiber in the loop, the WLL, the remote central office. In this case, the operating voltages are smaller than in the classical system. This makes the high voltage SLICs particularly suitable. The schematics of [Figure 4](#) shows the topologies most frequently used for these applications.

Figure 4. Protection of high voltage SLICs

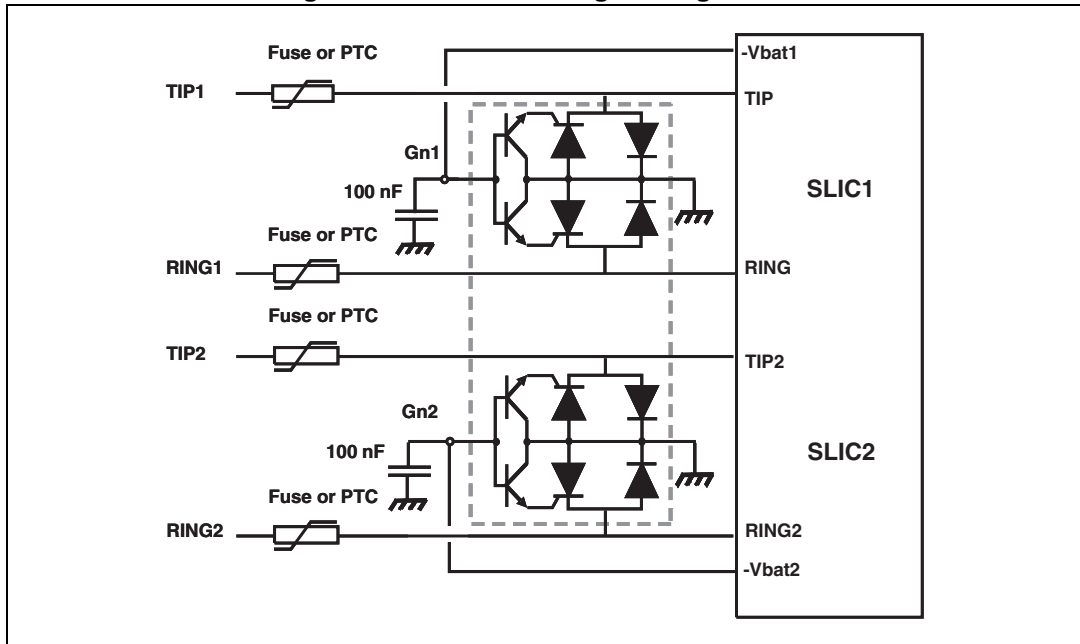

Figure 5. Surge peak current versus duration

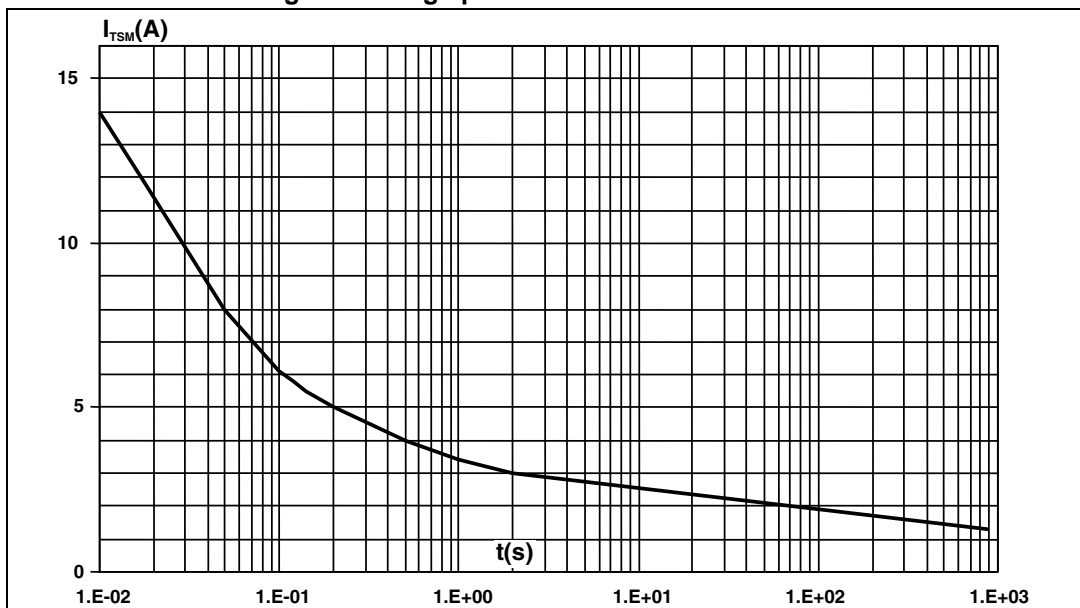
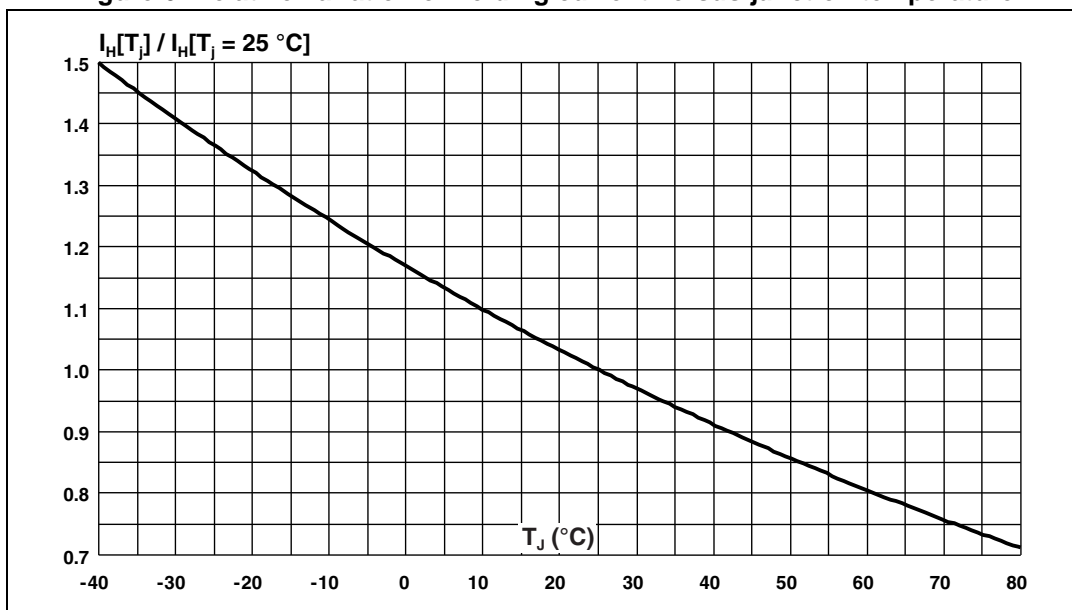

Figure 6. Relative variation of holding current versus junction temperature



3 Package information

- Epoxy meets UL94, V0
- Lead-free package

In order to meet environmental requirements, ST offers these devices in different grades of ECOPACK[®] packages, depending on their level of environmental compliance. ECOPACK[®] specifications, grade definitions and product status are available at: www.st.com. ECOPACK[®] is an ST trademark.

3.1 SO-8 package information

Figure 7. SO-8 package outline

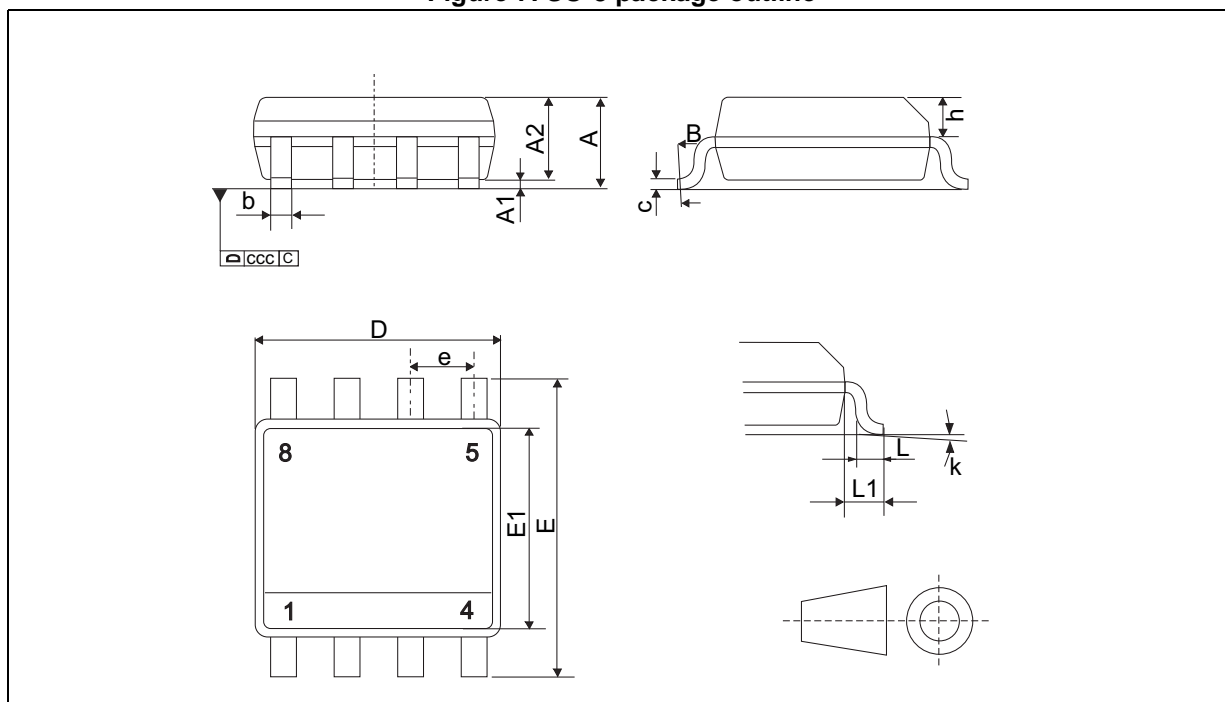
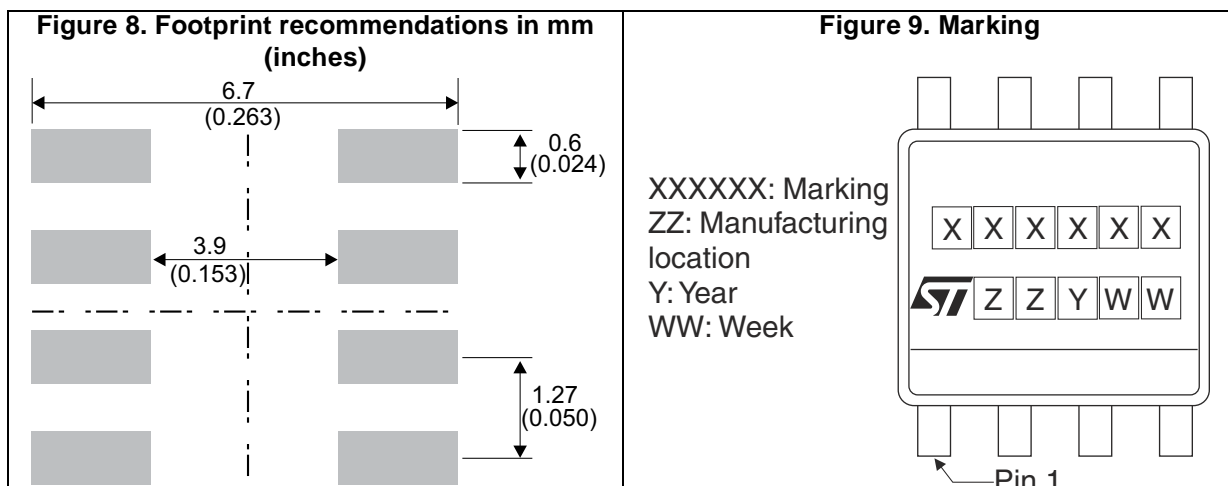

Table 6. SO-8 package mechanical data

Ref.	Dimensions					
	Millimeters			Inches		
	Min.	Typ.	Max.	Min.	Typ.	Max.
A			1.75			0.069
A1	0.1		0.25	0.004		0.010
A2	1.25			0.049		
b	0.28		0.48	0.011		0.019
c	0.17		0.23	0.007		0.009
D	4.80	4.90	5.00	0.189	0.193	0.197
E	5.80	6.00	6.20	0.228	0.236	0.244
E1	3.80	3.90	4.00	0.150	0.154	0.157
e		1.27			0.050	
h	0.25		0.50	0.010		0.020
L	0.40		1.27	0.016		0.050
L1		1.04			0.041	
k°	0		8	0		8
ccc			0.10			0.004



4 Ordering information

Figure 10. Ordering information scheme

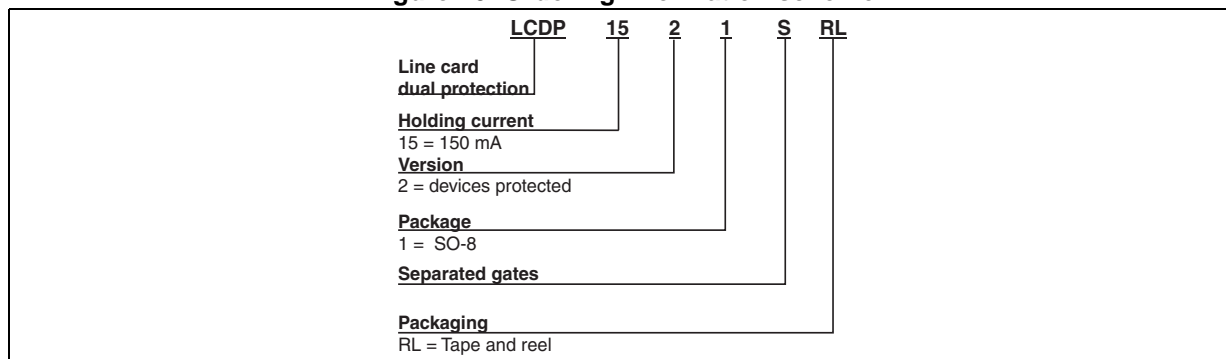

Table 7. Ordering information

Order code	Marking	Package	Weight	Base qty	Delivery mode
LCDP1521SRL	DP152S	SO-8	0.08 g	2500	Tape and reel

5 Revision history

Table 8. Document revision history

Date	Revision	Changes
24-Sep-2009	1	First issue.
23-Feb-2012	2	Standardized nomenclature for Gn and Gp.
20-May-2015	3	Updated Table 3 and package view.
02-Jul-2015	4	Updated package information.
08-Jul-2015	5	Updated Figure 7 .

IMPORTANT NOTICE – PLEASE READ CAREFULLY

STMicroelectronics NV and its subsidiaries ("ST") reserve the right to make changes, corrections, enhancements, modifications, and improvements to ST products and/or to this document at any time without notice. Purchasers should obtain the latest relevant information on ST products before placing orders. ST products are sold pursuant to ST's terms and conditions of sale in place at the time of order acknowledgement.

Purchasers are solely responsible for the choice, selection, and use of ST products and ST assumes no liability for application assistance or the design of Purchasers' products.

No license, express or implied, to any intellectual property right is granted by ST herein.

Resale of ST products with provisions different from the information set forth herein shall void any warranty granted by ST for such product.

ST and the ST logo are trademarks of ST. All other product or service names are the property of their respective owners.

Information in this document supersedes and replaces information previously supplied in any prior versions of this document.

© 2015 STMicroelectronics – All rights reserved