LM2586 SIMPLE SWITCHER[®] 3A Flyback Regulator with Shutdown

Check for Samples: [LM2586](#)

FEATURES

- Requires Few External Components
- Family of Standard Inductors and Transformers
- NPN Output Switches 3.0A, Can Stand Off 65V
- Wide Input Voltage Range: 4V to 40V
- Adjustable Switching Frequency: 100 kHz to 200 kHz
- External Shutdown Capability
- Draws Less Than 60 μ A When Shut Down
- Frequency Synchronization
- Current-mode Operation for Improved Transient Response, Line Regulation, and Current Limit
- Internal Soft-start Function Reduces In-rush Current During Start-up
- Output Transistor Protected by Current Limit, Under Voltage Lockout, and Thermal Shutdown
- System Output Voltage Tolerance of $\pm 4\%$ Max Over Line and Load Conditions

TYPICAL APPLICATIONS

- Flyback Regulator
- Forward Converter
- Multiple-output Regulator
- Simple Boost Regulator

DESCRIPTION

The LM2586 series of regulators are monolithic integrated circuits specifically designed for flyback, step-up (boost), and forward converter applications. The device is available in 4 different output voltage versions: 3.3V, 5.0V, 12V, and adjustable.

Requiring a minimum number of external components, these regulators are cost effective, and simple to use. Included in the datasheet are typical circuits of boost and flyback regulators. Also listed are selector guides for diodes and capacitors and a family of standard inductors and flyback transformers designed to work with these switching regulators.

The power switch is a 3.0A NPN device that can stand-off 65V. Protecting the power switch are current and thermal limiting circuits, and an undervoltage lockout circuit. This IC contains an adjustable frequency oscillator that can be programmed up to 200 kHz. The oscillator can also be synchronized with other devices, so that multiple devices can operate at the same switching frequency.

Other features include soft start mode to reduce in-rush current during start up, and current mode control for improved rejection of input voltage and output load transients and cycle-by-cycle current limiting. The device also has a shutdown pin, so that it can be turned off externally. An output voltage tolerance of $\pm 4\%$, within specified input voltages and output load conditions, is ensured for the power supply system.

Connection Diagrams

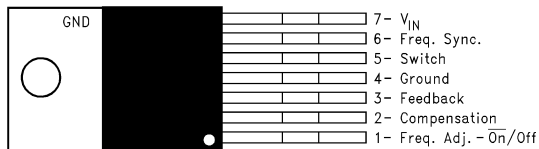

**Figure 1. Bent, Staggered Leads
7-Lead TO-220 (NDZ)
Top View
See Package Number NDZ0007B**

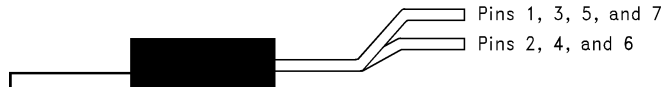

**Figure 2. Bent, Staggered Leads
7-Lead TO-220 (NDZ)
Side View**

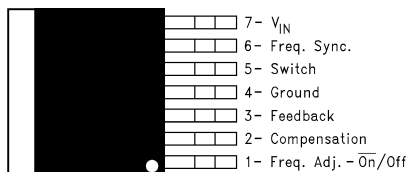

**Figure 3. 7-Lead DDPAK (KTW)
Top View
See Package Number KTW0007B**



**Figure 4. 7-Lead DDPAK (KTW)
Side View**



These devices have limited built-in ESD protection. The leads should be shorted together or the device placed in conductive foam during storage or handling to prevent electrostatic damage to the MOS gates.

Absolute Maximum Ratings ⁽¹⁾⁽²⁾

| | |
|---|------------------------------------|
| Input Voltage | $-0.4V \leq V_{IN} \leq 45V$ |
| Switch Voltage | $-0.4V \leq V_{SW} \leq 65V$ |
| Switch Current ⁽³⁾ | Internally Limited |
| Compensation Pin Voltage | $-0.4V \leq V_{COMP} \leq 2.4V$ |
| Feedback Pin Voltage | $-0.4V \leq V_{FB} \leq 2 V_{OUT}$ |
| ON /OFF Pin Voltage | $-0.4V \leq V_{SH} \leq 6V$ |
| Sync Pin Voltage | $-0.4V \leq V_{SYNC} \leq 2V$ |
| Power Dissipation ⁽⁴⁾ | Internally Limited |
| Storage Temperature Range | $-65^{\circ}C$ to $+150^{\circ}C$ |
| Lead Temperature (Soldering, 10 sec.) | $260^{\circ}C$ |
| Maximum Junction Temperature ⁽⁴⁾ | $150^{\circ}C$ |
| Minimum ESD Rating | (C = 100 pF, R = 1.5 kΩ) 2 kV |

- (1) If Military/Aerospace specified devices are required, please contact the Texas Instruments Sales Office/ Distributors for availability and specifications.
- (2) Absolute Maximum Ratings indicate limits beyond which damage to the device may occur. These ratings apply when the current is limited to less than 1.2 mA for pins 1, 2, 3, and 6. Operating ratings indicate conditions for which the device is intended to be functional, but device parameter specifications may not be ensured under these conditions. For ensured specifications and test conditions, see the [Electrical Characteristics](#).
- (3) Note that switch current and output current are not identical in a step-up regulator. Output current cannot be internally limited when the LM2586 is used as a step-up regulator. To prevent damage to the switch, the output current must be externally limited to 3A. However, output current is internally limited when the LM2586 is used as a flyback regulator (see the [Application Hints](#) section for more information).
- (4) The junction temperature of the device (T_J) is a function of the ambient temperature (T_A), the junction-to-ambient thermal resistance (θ_{JA}), and the power dissipation of the device (P_D). A thermal shutdown will occur if the temperature exceeds the maximum junction temperature of the device: $P_D \times \theta_{JA} + T_{A(MAX)} \geq T_{J(MAX)}$. For a safe thermal design, check that the maximum power dissipated by the device is less than: $P_D \leq [T_{J(MAX)} - T_{A(MAX)}] / \theta_{JA}$. When calculating the maximum allowable power dissipation, derate the maximum junction temperature—this ensures a margin of safety in the thermal design.

Operating Ratings

| | |
|-----------------------|--|
| Supply Voltage | $4V \leq V_{IN} \leq 40V$ |
| Output Switch Voltage | $0V \leq V_{SW} \leq 60V$ |
| Output Switch Current | $I_{SW} \leq 3.0A$ |
| Junction Temp. Range | $-40^{\circ}C \leq T_J \leq +125^{\circ}C$ |

Electrical Characteristics LM2586-3.3

Specifications with standard type face are for $T_J = 25^{\circ}C$, and those in **bold type face** apply over full **Operating Temperature Range**. Unless otherwise specified, $V_{IN} = 5V$.

| Symbol | Parameters | Conditions | Typical | Min | Max | Units |
|---|-----------------------------------|--|---------|--------------------|--------------------|-------|
| SYSTEM PARAMETERS Test Circuit of Figure 20 ⁽¹⁾ | | | | | | |
| V_{OUT} | Output Voltage | $V_{IN} = 4V$ to $12V$ $I_{LOAD} = 0.3$ to $1.2A$ | 3.3 | 3.17/3.14 | 3.43/3.46 | V |
| $\Delta V_{OUT}/\Delta V_{IN}$ | Line Regulation | $V_{IN} = 4V$ to $12V$ $I_{LOAD} = 0.3A$ | 20 | | 50/100 | mV |
| $\Delta V_{OUT}/\Delta I_{LOAD}$ | Load Regulation | $V_{IN} = 12V$ $I_{LOAD} = 0.3A$ to $1.2A$ | 20 | | 50/100 | mV |
| η | Efficiency | $V_{IN} = 5V$, $I_{LOAD} = 0.3A$ | 76 | | | % |
| UNIQUE DEVICE PARAMETERS ⁽²⁾ | | | | | | |
| V_{REF} | Output Reference Voltage | Measured at Feedback Pin $V = 1.0V$ | 3.3 | 3.242/3.234 | 3.358/3.366 | V |
| ΔV_{REF} | Reference Voltage Line Regulation | $V_{IN} = 4V$ to $40V$ | 2.0 | | | mV |
| G_M | Error Amp Transconductance | $I_{COMP} = -30 \mu A$ to $+30 \mu A$ $V_{COMP} = 1.0V$ | 1.193 | 0.678 | 2.259 | mmho |
| A_{VOL} | Error Amp Voltage Gain | $V_{COMP} = 0.5V$ to $1.6V$ $R_{COMP} = 1.0 M\Omega$ ⁽³⁾ | 260 | 151/75 | | V/V |

- (1) External components such as the diode, inductor, input and output capacitors can affect switching regulator performance. When the LM2586 is used as shown in [Figure 20](#) and [Figure 21](#), system performance will be as specified by the system parameters.
- (2) All room temperature limits are 100% production tested, and all limits at temperature extremes are specified via correlation using standard Statistical Quality Control (SQC) methods.
- (3) A 1.0 M Ω resistor is connected to the compensation pin (which is the error amplifier output) to ensure accuracy in measuring A_{VOL} .

LM2586-5.0

| Symbol | Parameters | Conditions | Typical | Min | Max | Units |
|---|-----------------------------------|--|---------|--------------------|--------------------|-------|
| SYSTEM PARAMETERS Test Circuit of Figure 20 ⁽¹⁾ | | | | | | |
| V_{OUT} | Output Voltage | $V_{IN} = 4V$ to $12V$ $I_{LOAD} = 0.3A$ to $1.1A$ | 5.0 | 4.80/4.75 | 5.20/5.25 | V |
| $\Delta V_{OUT}/\Delta V_{IN}$ | Line Regulation | $V_{IN} = 4V$ to $12V$ $I_{LOAD} = 0.3A$ | 20 | | 50/100 | mV |
| $\Delta V_{OUT}/\Delta I_{LOAD}$ | Load Regulation | $V_{IN} = 12V$ $I_{LOAD} = 0.3A$ to $1.1A$ | 20 | | 50/100 | mV |
| η | Efficiency | $V_{IN} = 12V$, $I_{LOAD} = 0.6A$ | 80 | | | % |
| UNIQUE DEVICE PARAMETERS ⁽²⁾ | | | | | | |
| V_{REF} | Output Reference Voltage | Measured at Feedback Pin $V_{COMP} = 1.0V$ | 5.0 | 4.913/4.900 | 5.088/5.100 | V |
| ΔV_{REF} | Reference Voltage Line Regulation | $V_{IN} = 4V$ to $40V$ | 3.3 | | | mV |
| G_M | Error Amp Transconductance | $I_{COMP} = -30 \mu A$ to $+30 \mu A$ $V_{COMP} = 1.0V$ | 0.750 | 0.447 | 1.491 | mmho |

- (1) External components such as the diode, inductor, input and output capacitors can affect switching regulator performance. When the LM2586 is used as shown in [Figure 20](#) and [Figure 21](#), system performance will be as specified by the system parameters.
- (2) All room temperature limits are 100% production tested, and all limits at temperature extremes are specified via correlation using standard Statistical Quality Control (SQC) methods.

LM2586-5.0 (continued)

| Symbol | Parameters | Conditions | Typical | Min | Max | Units |
|-----------|------------------------|---|---------|-------|-----|-------|
| A_{VOL} | Error Amp Voltage Gain | $V_{COMP} = 0.5V$ to $1.6V$ $R_{COMP} = 1.0\text{ M}\Omega$ ⁽³⁾ | 165 | 99/49 | | V/V |

(3) A 1.0 M Ω resistor is connected to the compensation pin (which is the error amplifier output) to ensure accuracy in measuring A_{VOL} .

LM2586-12

| Symbol | Parameters | Conditions | Typical | Min | Max | Units |
|---|-----------------------------------|---|---------|-------------|-------------|-------|
| SYSTEM PARAMETERS Test Circuit of Figure 21 ⁽¹⁾ | | | | | | |
| V_{OUT} | Output Voltage | $V_{IN} = 4V$ to $10V$ $I_{LOAD} = 0.2A$ to $0.8A$ | 12.0 | 11.52/11.40 | 12.48/12.60 | V |
| $\frac{\Delta V_{OUT}}{\Delta V_{IN}}$ | Line Regulation | $V_{IN} = 4V$ to $10V$ $I_{LOAD} = 0.2A$ | 20 | | 100/200 | mV |
| $\frac{\Delta V_{OUT}}{\Delta I_{LOAD}}$ | Load Regulation | $V_{IN} = 10V$ $I_{LOAD} = 0.2A$ to $0.8A$ | 20 | | 100/200 | mV |
| η | Efficiency | $V_{IN} = 10V$, $I_{LOAD} = 0.6A$ | 93 | | | % |
| UNIQUE DEVICE PARAMETERS ⁽²⁾ | | | | | | |
| V_{REF} | Output Reference Voltage | Measured at Feedback Pin $V_{COMP} = 1.0V$ | 12.0 | 11.79/11.76 | 12.21/12.24 | V |
| ΔV_{REF} | Reference Voltage Line Regulation | $V_{IN} = 4V$ to $40V$ | 7.8 | | | mV |
| G_M | Error Amp Transconductance | $I_{COMP} = -30\text{ }\mu A$ to $+30\text{ }\mu A$ $V_{COMP} = 1.0V$ | 0.328 | 0.186 | 0.621 | mmho |
| A_{VOL} | Error Amp Voltage Gain | $V_{COMP} = 0.5V$ to $1.6V$ $R_{COMP} = 1.0\text{ M}\Omega$ ⁽³⁾ | 70 | 41/21 | | V/V |

- (1) External components such as the diode, inductor, input and output capacitors can affect switching regulator performance. When the LM2586 is used as shown in [Figure 20](#) and [Figure 21](#), system performance will be as specified by the system parameters.
- (2) All room temperature limits are 100% production tested, and all limits at temperature extremes are specified via correlation using standard Statistical Quality Control (SQC) methods.
- (3) A 1.0 M Ω resistor is connected to the compensation pin (which is the error amplifier output) to ensure accuracy in measuring A_{VOL} .

LM2586-ADJ

| Symbol | Parameters | Conditions | Typical | Min | Max | Units |
|---|---|---|---------|-------------|-------------|-------|
| SYSTEM PARAMETERS Test Circuit of Figure 21 ⁽¹⁾ | | | | | | |
| V _{OUT} | Output Voltage | V _{IN} = 4V to 10V I _{LOAD} = 0.2A to 0.8A | 12.0 | 11.52/11.40 | 12.48/12.60 | V |
| ΔV _{OUT} /ΔV _{IN} | Line Regulation | V _{IN} = 4V to 10V I _{LOAD} = 0.2A | 20 | | 100/200 | mV |
| ΔV _{OUT} /ΔI _{LOAD} | Load Regulation | V _{IN} = 10V I _{LOAD} = 0.2A to 0.8A | 20 | | 100/200 | mV |
| η | Efficiency | V _{IN} = 10V, I _{LOAD} = 0.6A | 93 | | | % |
| UNIQUE DEVICE PARAMETERS ⁽²⁾ | | | | | | |
| V _{REF} | Output Reference Voltage | Measured at Feedback Pin V _{COMP} = 1.0V | 1.230 | 1.208/1.205 | 1.252/1.255 | V |
| ΔV _{REF} | Reference Voltage Line Regulation | V _{IN} = 4V to 40V | 1.5 | | | mV |
| G _M | Error Amp Transconductance | I _{COMP} = -30 μA to +30 μA V _{COMP} = 1.0V | 3.200 | 1.800 | 6.000 | mmho |
| A _{VOL} | Error Amp Voltage Gain | V _{COMP} = 0.5V to 1.6V, R _{COMP} = 1.0 MΩ ⁽³⁾ | 670 | 400/200 | | V/V |
| I _B | Error Amp Input Bias Current | V _{COMP} = 1.0V | 125 | | 425/600 | nA |
| COMMON DEVICE PARAMETERS for all versions ⁽²⁾ | | | | | | |
| I _S | Input Supply Current | Switch Off ⁽⁴⁾ | 11 | | 15.5/16.5 | mA |
| | | I _{SWITCH} = 1.8A | 50 | | 100/115 | mA |
| I _{S/D} | Shutdown Input Supply Current | V _{SH} = 3V | 16 | | 100/300 | μA |
| V _{UV} | Input Supply Undervoltage Lockout | R _{LOAD} = 100Ω | 3.30 | 3.05 | 3.75 | V |
| f _O | Oscillator Frequency | Measured at Switch Pin R _{LOAD} = 100Ω, V _{COMP} = 1.0V Freq. Adj. Pin Open (Pin 1) | 100 | 85/75 | 115/125 | kHz |
| | | R _{SET} = 22 kΩ | 200 | | | kHz |
| f _{SC} | Short-Circuit Frequency | Measured at Switch Pin R _{LOAD} = 100Ω V _{FEEDBACK} = 1.15V | 25 | | | kHz |
| V _{EAO} | Error Amplifier Output Swing | Upper Limit ⁽⁵⁾ | 2.8 | 2.6/2.4 | | V |
| | | Lower Limit ⁽⁴⁾ | 0.25 | | 0.40/0.55 | V |
| I _{EAO} | Error Amp Output Current (Source or Sink) | See ⁽⁶⁾ | 165 | 110/70 | 260/320 | μA |
| I _{SS} | Soft Start Current | V _{FEEDBACK} = 0.92V V _{COMP} = 1.0V | 11.0 | 8.0/7.0 | 17.0/19.0 | μA |
| D _{MAX} | Maximum Duty Cycle | R _{LOAD} = 100Ω ⁽⁵⁾ | 98 | 93/90 | | % |
| I _L | Switch Leakage Current | Switch Off V _{SWITCH} = 60V | 15 | | 300/600 | μA |
| V _{SUS} | Switch Sustaining Voltage | dV/dT = 1.5V/ns | | 65 | | V |
| V _{SAT} | Switch Saturation Voltage | I _{SWITCH} = 3.0A | 0.45 | | 0.65/0.9 | V |

- (1) External components such as the diode, inductor, input and output capacitors can affect switching regulator performance. When the LM2586 is used as shown in [Figure 20](#) and [Figure 21](#), system performance will be as specified by the system parameters.
- (2) All room temperature limits are 100% production tested, and all limits at temperature extremes are specified via correlation using standard Statistical Quality Control (SQC) methods.
- (3) A 1.0 MΩ resistor is connected to the compensation pin (which is the error amplifier output) to ensure accuracy in measuring A_{VOL}.
- (4) To measure this parameter, the feedback voltage is set to a high value, depending on the output version of the device, to force the error amplifier output low and the switch off.
- (5) To measure this parameter, the feedback voltage is set to a low value, depending on the output version of the device, to force the error amplifier output high and the switch on.
- (6) To measure the worst-case error amplifier output current, the LM2586 is tested with the feedback voltage set to its low value ([Note 4](#)) and at its high value ([Note 5](#)).

LM2586-ADJ (continued)

| Symbol | Parameters | Conditions | Typical | Min | Max | Units |
|---------------|---|--|---------|-------------------|-------------------|----------------------|
| I_{CL} | NPN Switch Current Limit | | 4.0 | 3.0 | 7.0 | A |
| V_{STH} | Synchronization Threshold Voltage | $F_{SYNC} = 200 \text{ kHz}$ $V_{COMP} = 1V, V_{IN} = 5V$ | 0.75 | 0.625/0.40 | 0.875/1.00 | V |
| I_{SYNC} | Synchronization Pin Current | $V_{IN} = 5V$ $V_{COMP} = 1V, V_{SYNC} = V_{STH}$ | 100 | | 200 | μA |
| V_{SHTH} | $\overline{\text{ON}}/\text{OFF}$ Pin (Pin 1) Threshold Voltage | $V_{COMP} = 1V$ (7) | 1.6 | 1.0/0.8 | 2.2/2.4 | V |
| I_{SH} | $\overline{\text{ON}}/\text{OFF}$ Pin (Pin 1) Current | $V_{COMP} = 1V$ $V_{SH} = V_{SHTH}$ | 40 | 15/10 | 65/75 | μA |
| θ_{JA} | Thermal Resistance | NDZ Package, Junction to Ambient ⁽⁸⁾ | 65 | | | $^{\circ}\text{C/W}$ |
| θ_{JA} | | NDZ Package, Junction to Ambient ⁽⁹⁾ | 45 | | | |
| θ_{JC} | | NDZ Package, Junction to Case | 2 | | | |
| θ_{JA} | | KTW Package, Junction to Ambient ⁽¹⁰⁾ | 56 | | | |
| θ_{JA} | | KTW Package, Junction to Ambient ⁽¹¹⁾ | 35 | | | |
| θ_{JA} | | KTW Package, Junction to Ambient ⁽¹²⁾ | 26 | | | |
| θ_{JC} | | KTW Package, Junction to Case | 2 | | | |

- (7) When testing the minimum value, do not sink current from this pin— isolate it with a diode. If current is drawn from this pin, the frequency adjust circuit will begin operation (Figure 55).
- (8) Junction to ambient thermal resistance (no external heat sink) for the 7 lead TO-220 package mounted vertically, with ½ inch leads in a socket, or on a PC board with minimum copper area.
- (9) Junction to ambient thermal resistance (no external heat sink) for the 7 lead TO-220 package mounted vertically, with ½ inch leads soldered to a PC board containing approximately 4 square inches of (1 oz.) copper area surrounding the leads.
- (10) Junction to ambient thermal resistance for the 7 lead DDPACK mounted horizontally against a PC board area of 0.136 square inches (the same size as the DDPACK package) of 1 oz. (0.0014 in. thick) copper.
- (11) Junction to ambient thermal resistance for the 7 lead DDPACK mounted horizontally against a PC board area of 0.4896 square inches (3.6 times the area of the DDPACK package) of 1 oz. (0.0014 in. thick) copper.
- (12) Junction to ambient thermal resistance for the 7 lead DDPACK mounted horizontally against a PC board copper area of 1.0064 square inches (7.4 times the area of the DDPACK package) of 1 oz. (0.0014 in. thick) copper. Additional copper area will reduce thermal resistance further. See the thermal model in **Switchers Made Simple**® software.

Typical Performance Characteristics

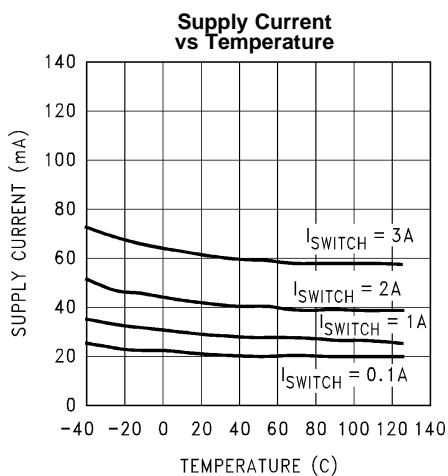

Figure 5.

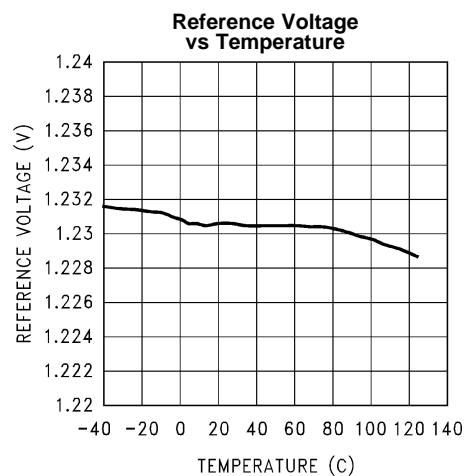

Figure 6.

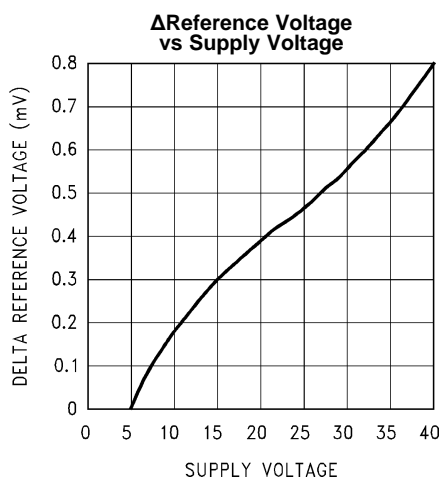

Figure 7.

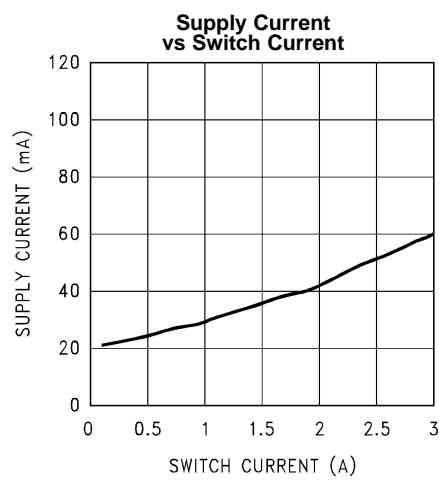

Figure 8.

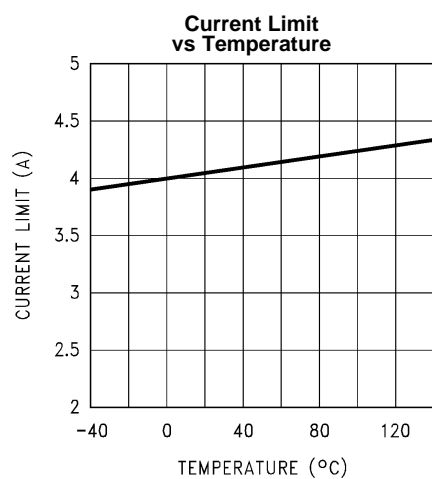

Figure 9.

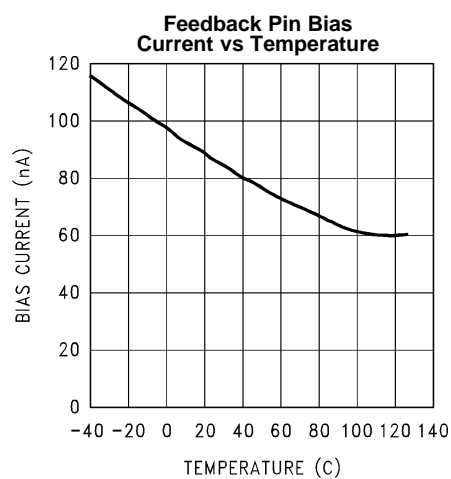

Figure 10.

Typical Performance Characteristics (continued)

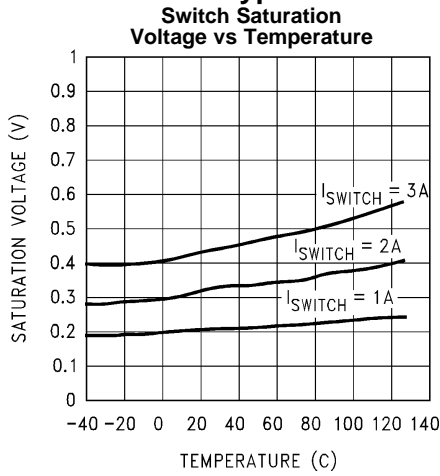

Figure 11.

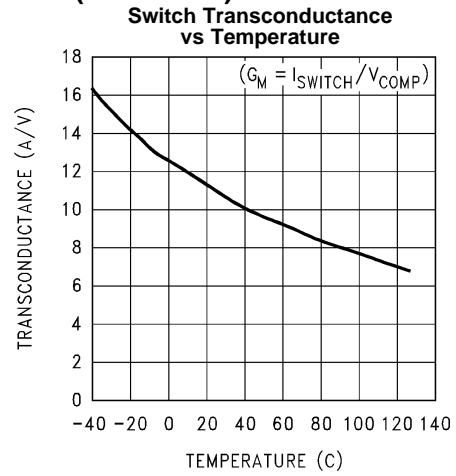

Figure 12.

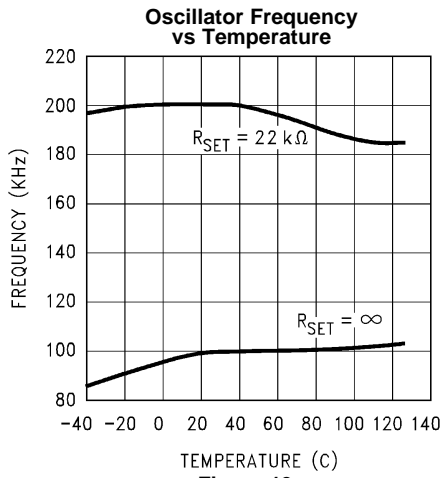

Figure 13.

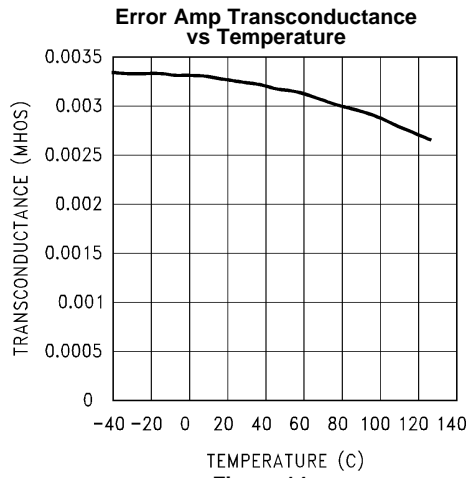

Figure 14.

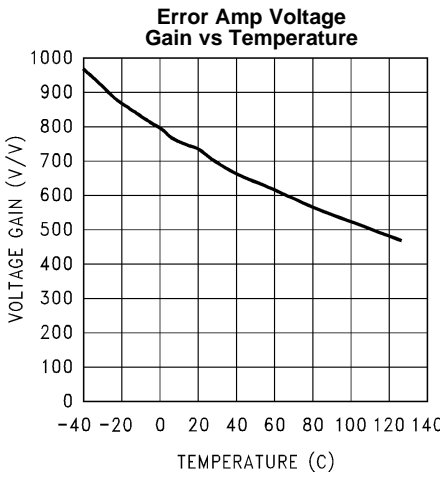

Figure 15.

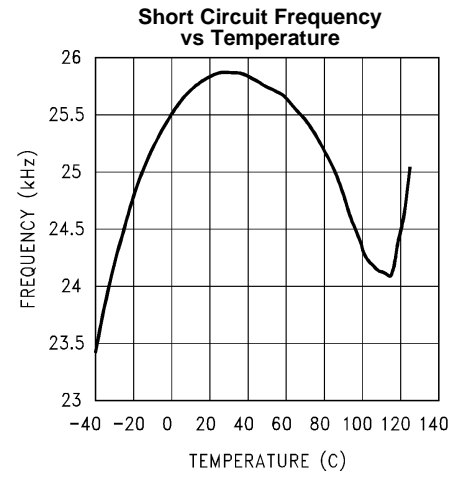

Figure 16.

Typical Performance Characteristics (continued)

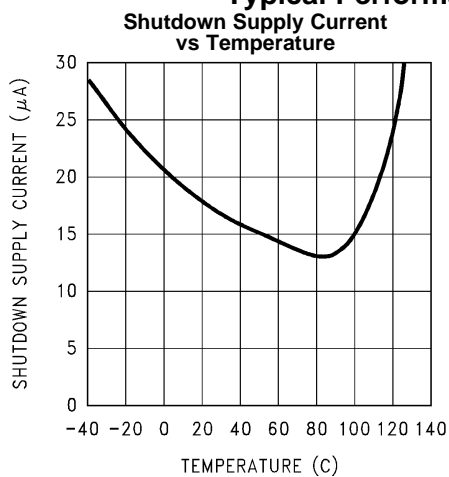

Figure 17.

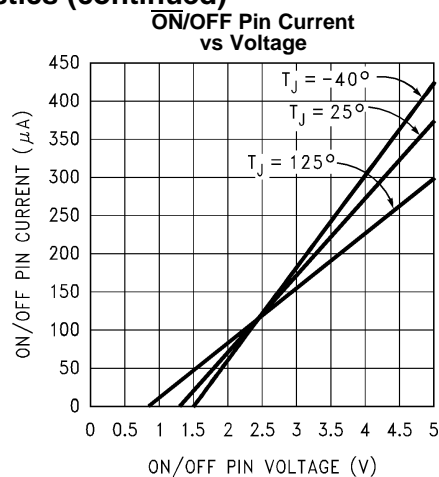

Figure 18.

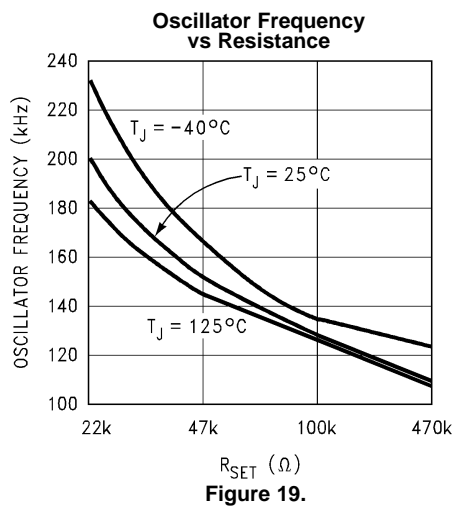
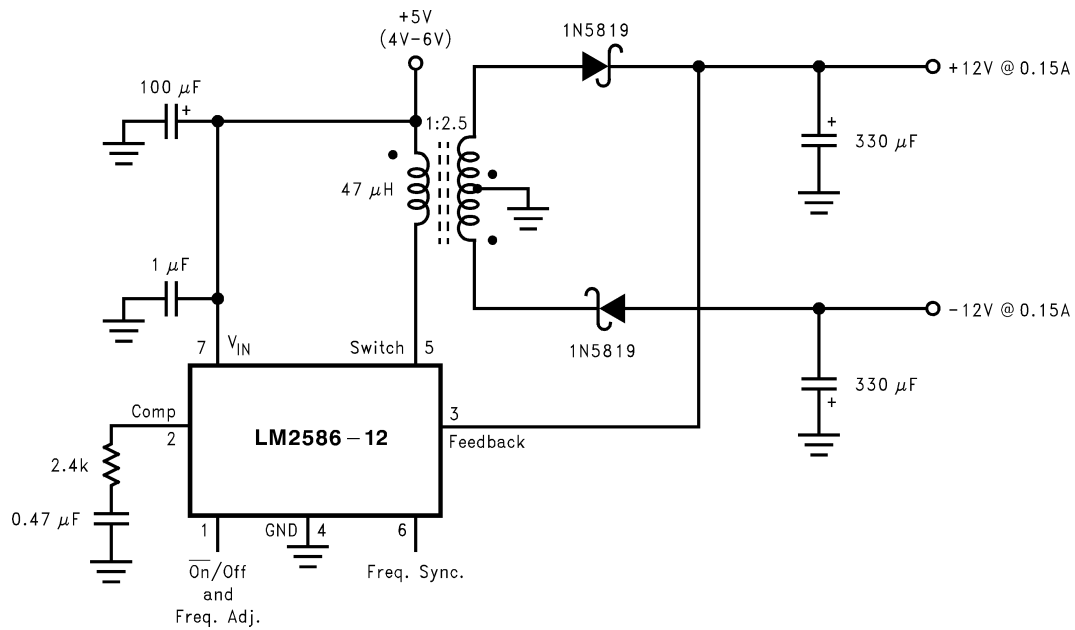
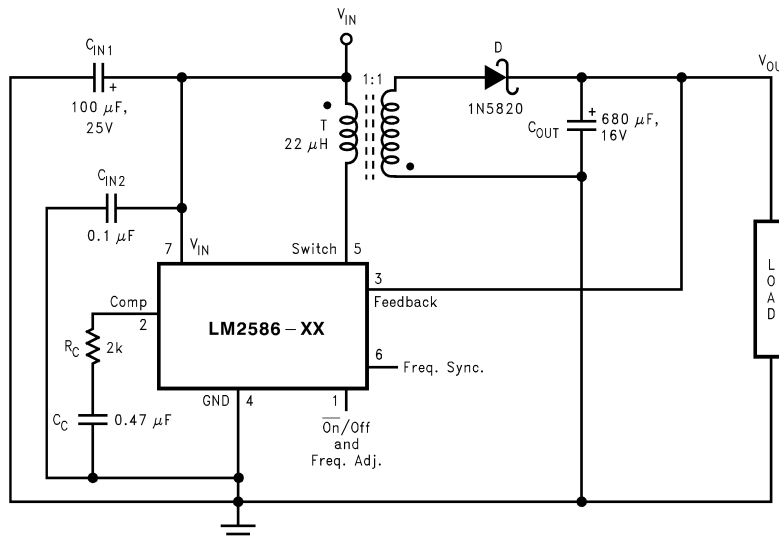

Figure 19.

Flyback Regulator



Test Circuits



- C_{IN1}—100 μF, 25V Aluminum Electrolytic
- C_{IN2}—0.1 μF Ceramic
- T—22 μH, 1:1 Schott #67141450
- D—1N5820
- C_{OUT}—680 μF, 16V Aluminum Electrolytic
- C_C—0.47 μF Ceramic
- R_C—2k

Figure 20. LM2586-3.3 and LM2586-5.0

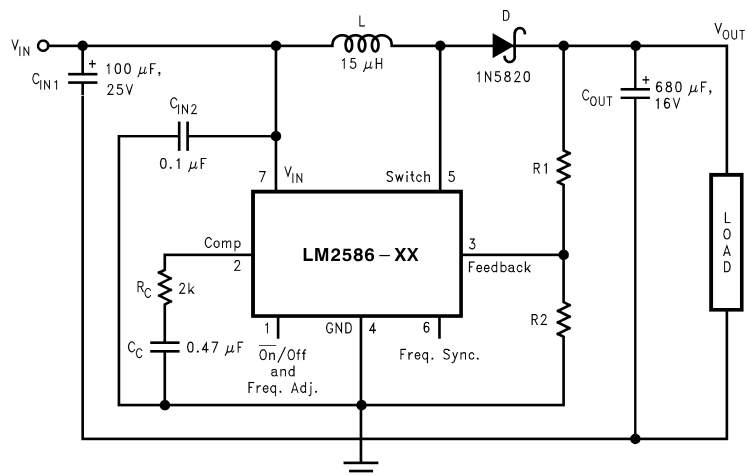

C_{IN1} —100 μF , 25V Aluminum Electrolytic
 C_{IN2} —0.1 μF Ceramic
 L —15 μH , Renco #RL-5472-5
 D —1N5820
 C_{OUT} —680 μF , 16V Aluminum Electrolytic
 C_C —0.47 μF Ceramic
 R_C —2k
 For 12V Devices: R_1 = Short (0Ω) and 2 = Open
 For ADJ Devices: R_1 = 48.75k, $\pm 0.1\%$ and 2 = 5.62k, $\pm 0.1\%$

Figure 21. LM2586-12 and LM2586-ADJ

Block Diagram

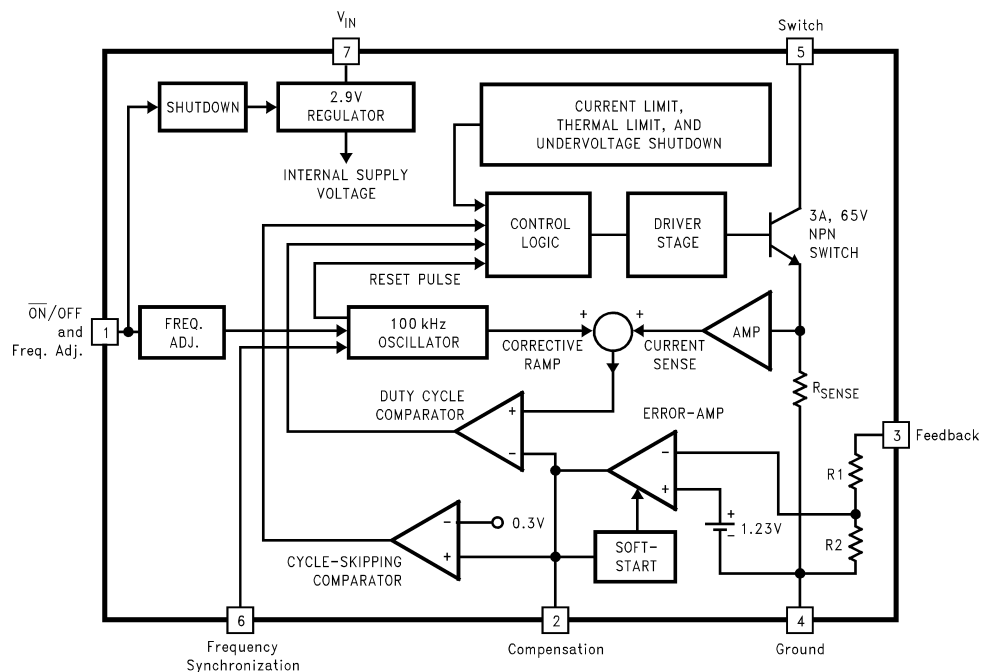

For Fixed Versions
 3.3V, R_1 = 3.4k, R_2 = 2k
 5.0V, R_1 = 6.15k, R_2 = 2k
 12V, R_1 = 8.73k, R_2 = 1k
 For Adj. Version
 R_1 = Short (0Ω), R_2 = Open

Flyback Regulator Operation

The LM2586 is ideally suited for use in the flyback regulator topology. The flyback regulator can produce a single output voltage, such as the one shown in Figure 22, or multiple output voltages. In Figure 22, the flyback regulator generates an output voltage that is inside the range of the input voltage. This feature is unique to flyback regulators and cannot be duplicated with buck or boost regulators.

The operation of a flyback regulator is as follows (refer to Figure 22): when the switch is on, current flows through the primary winding of the transformer, T1, storing energy in the magnetic field of the transformer. Note that the primary and secondary windings are out of phase, so no current flows through the secondary when current flows through the primary. When the switch turns off, the magnetic field collapses, reversing the voltage polarity of the primary and secondary windings. Now rectifier D1 is forward biased and current flows through it, releasing the energy stored in the transformer. This produces voltage at the output.

The output voltage is controlled by modulating the peak switch current. This is done by feeding back a portion of the output voltage to the error amp, which amplifies the difference between the feedback voltage and a 1.230V reference. The error amp output voltage is compared to a ramp voltage proportional to the switch current (i.e., inductor current during the switch on time). The comparator terminates the switch on time when the two voltages are equal, thereby controlling the peak switch current to maintain a constant output voltage.

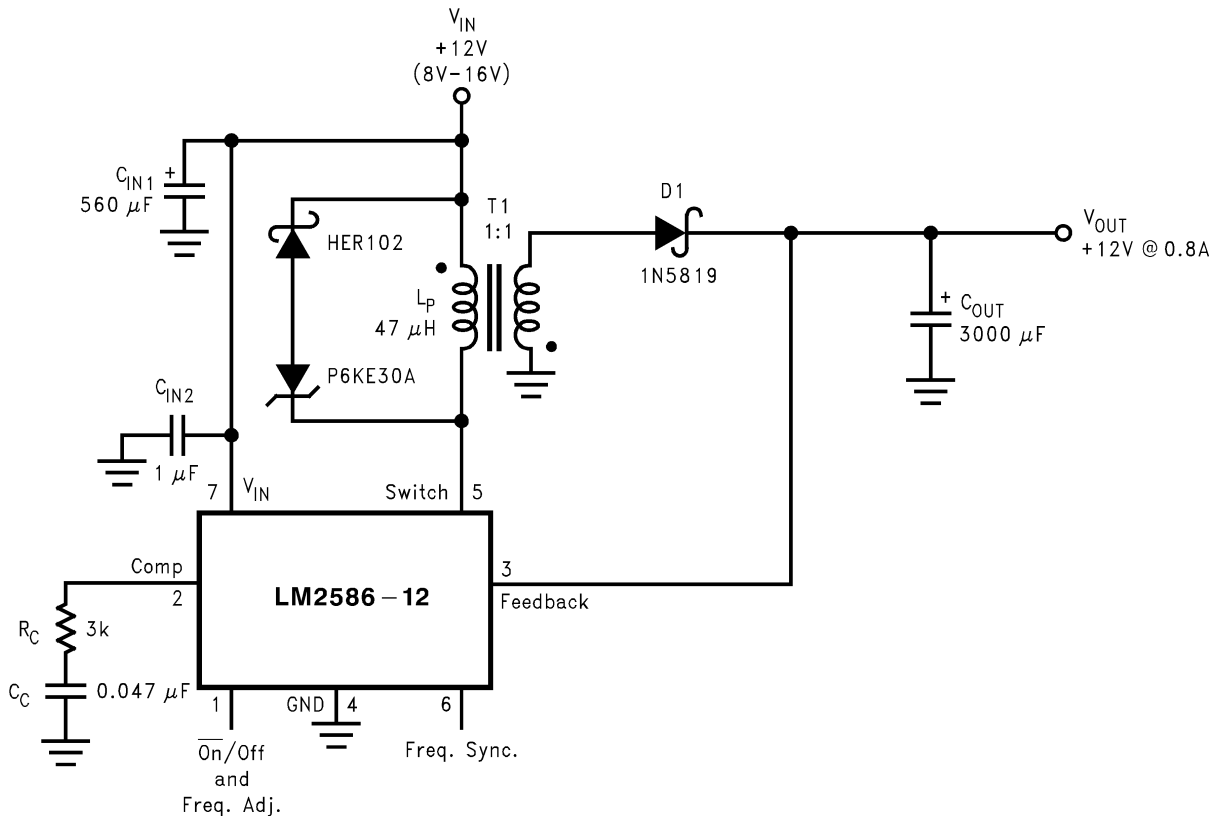

As shown in Figure 22, the LM2586 can be used as a flyback regulator by using a minimum number of external components. The switching waveforms of this regulator are shown in Figure 23. Typical Performance Characteristics observed during the operation of this circuit are shown in Figure 24.

Figure 22. 12V Flyback Regulator Design Example

Typical Performance Characteristics

- A: Switch Voltage, 20V/div
- B: Switch Current, 2A/div
- C: Output Rectifier Current, 2A/div
- D: Output Ripple Voltage, 50 mV/div AC-Coupled

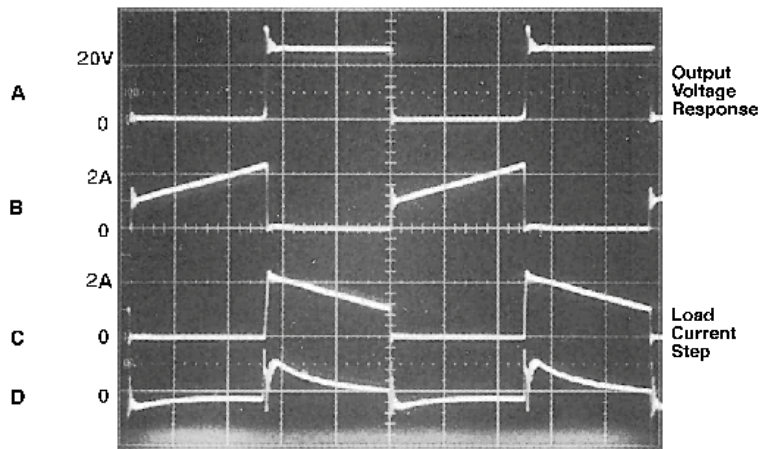

Figure 23. Switching Waveforms

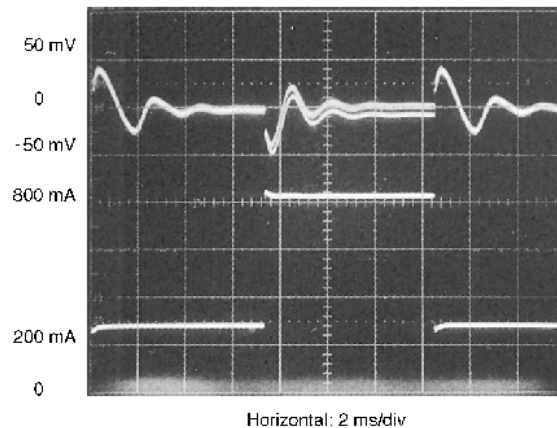

Figure 24. V_{OUT} Response to Load Current Step

Typical Flyback Regulator Applications

Figure 25 through Figure 30 show six typical flyback applications, varying from single output to triple output. Each drawing contains the part number(s) and manufacturer(s) for every component except the transformer. For the transformer part numbers and manufacturers' names, see Table 1. For applications with different output voltages—requiring the LM2586-ADJ—or different output configurations that do not match the standard configurations, refer to the **Switchers Made Simple** software.

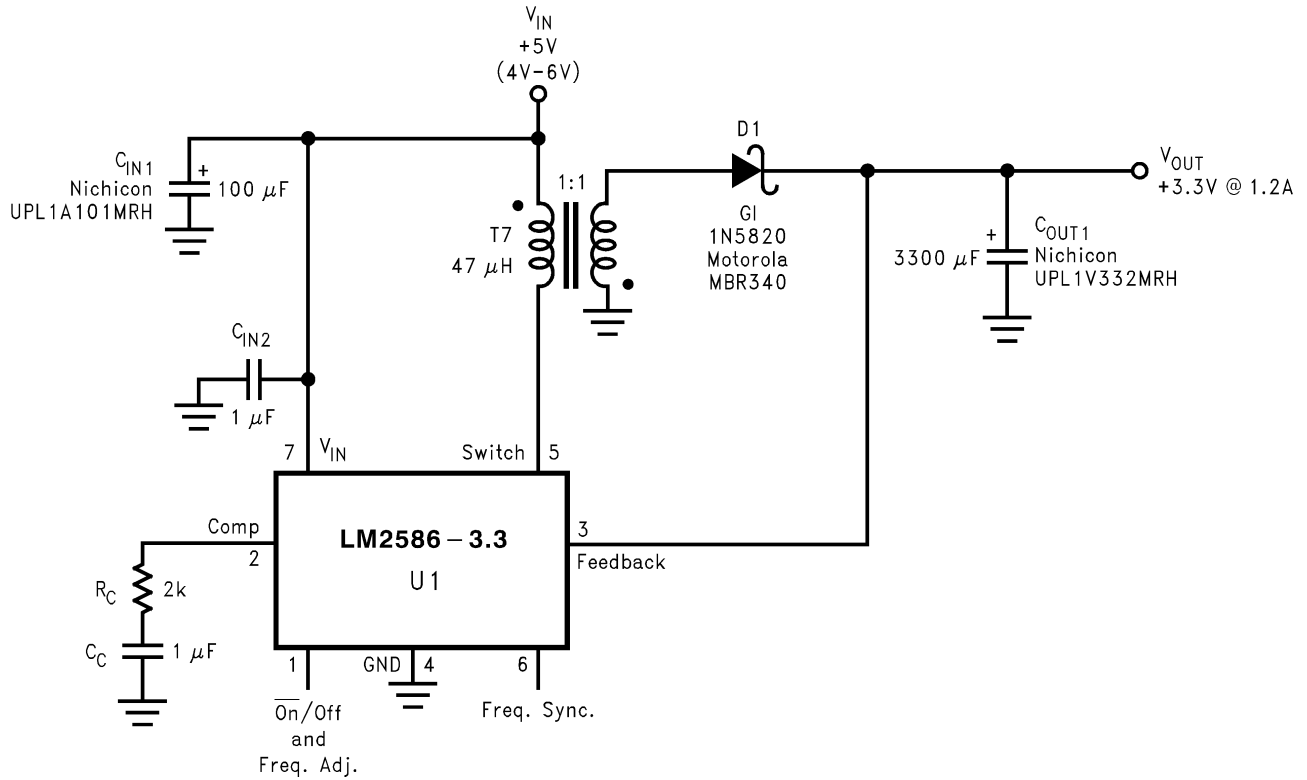

Figure 25. Single-Output Flyback Regulator

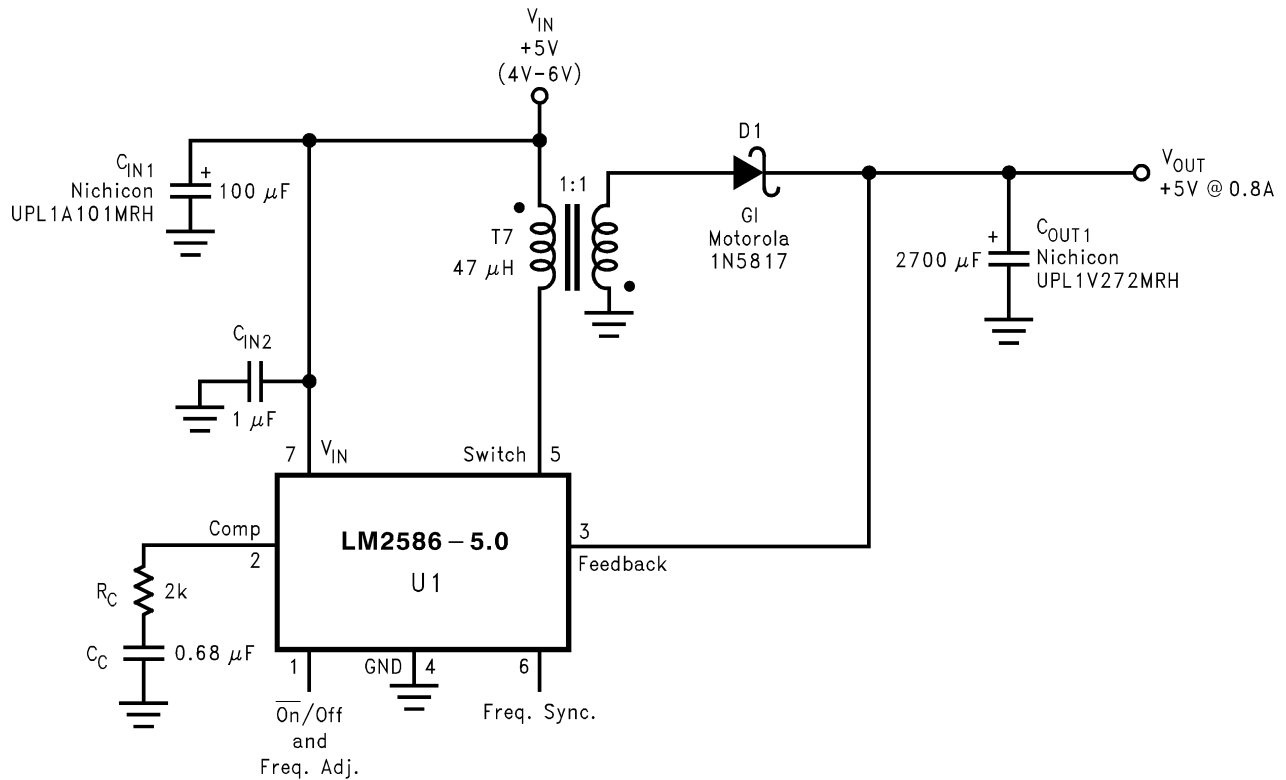

Figure 26. Single-Output Flyback Regulator

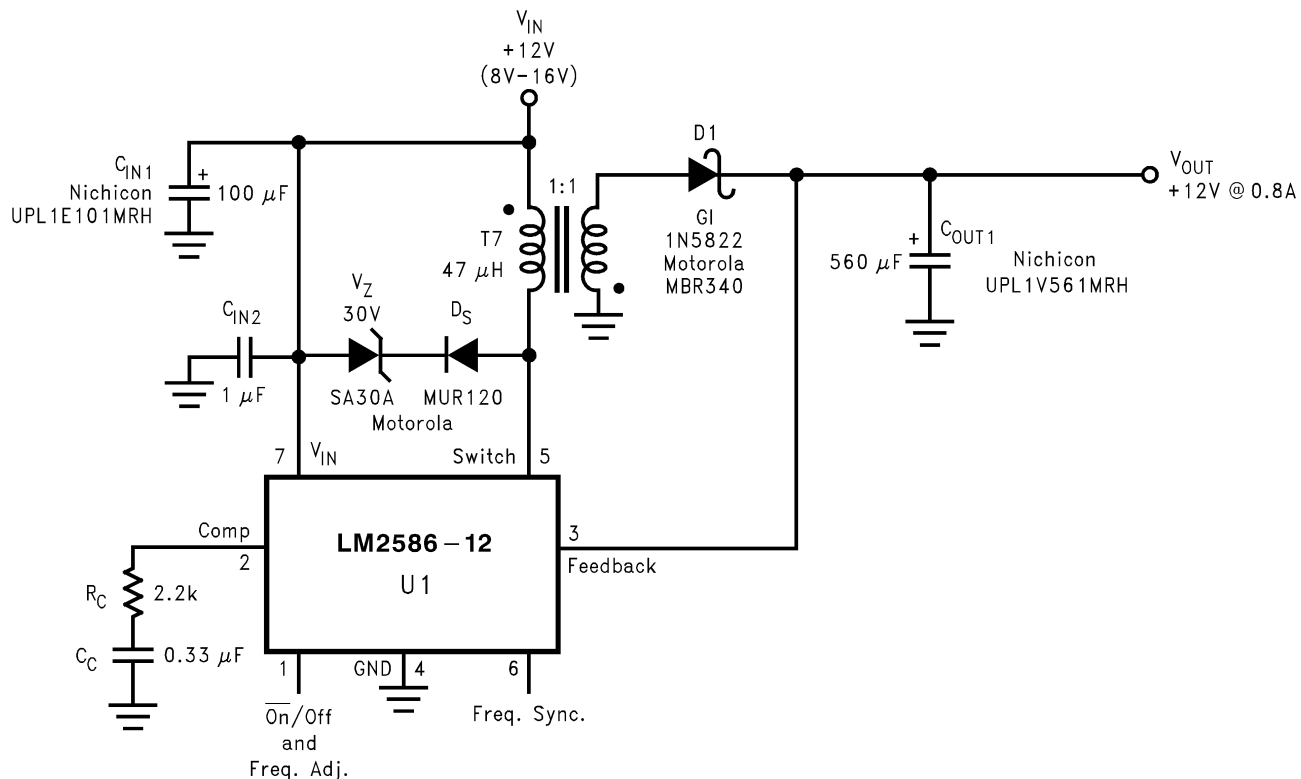

Figure 27. Single-Output Flyback Regulator

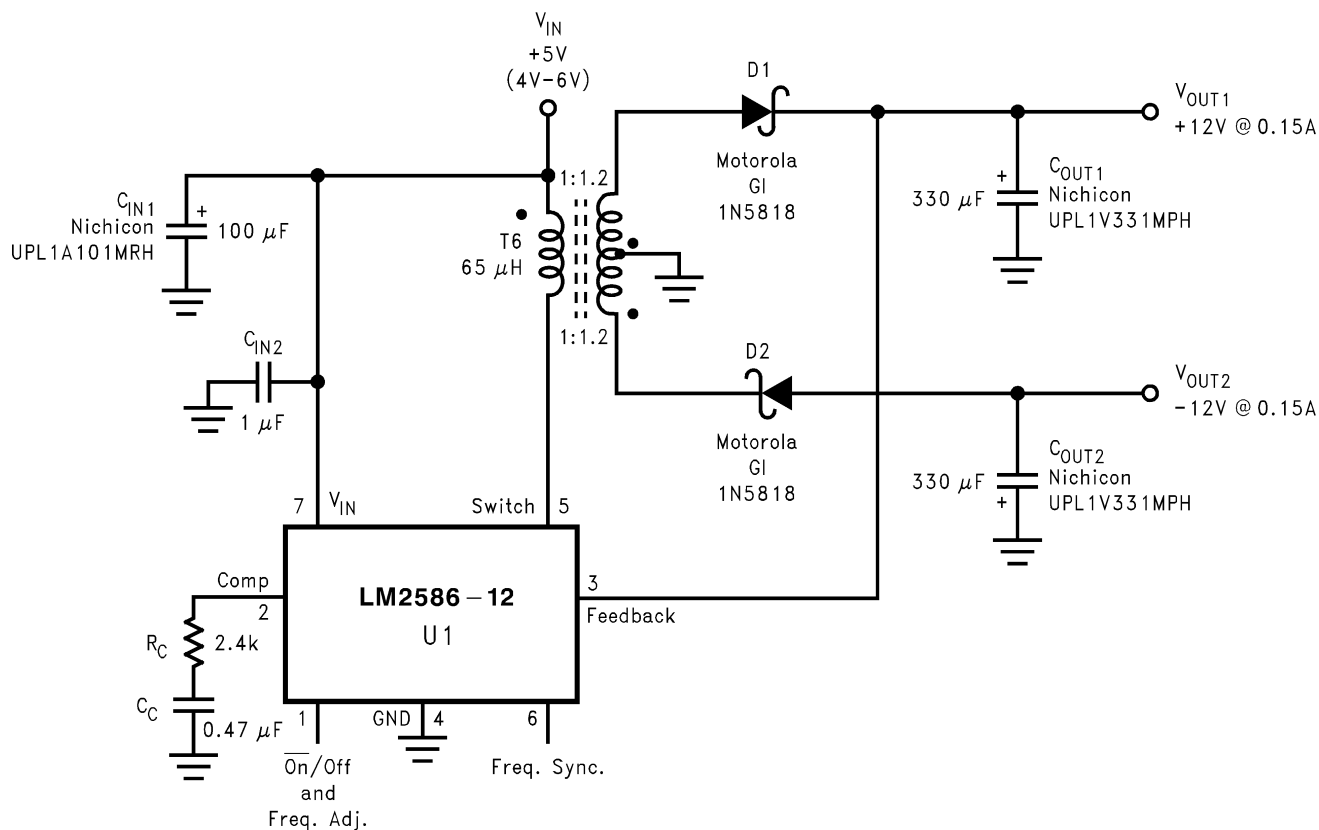

Figure 28. Dual-Output Flyback Regulator

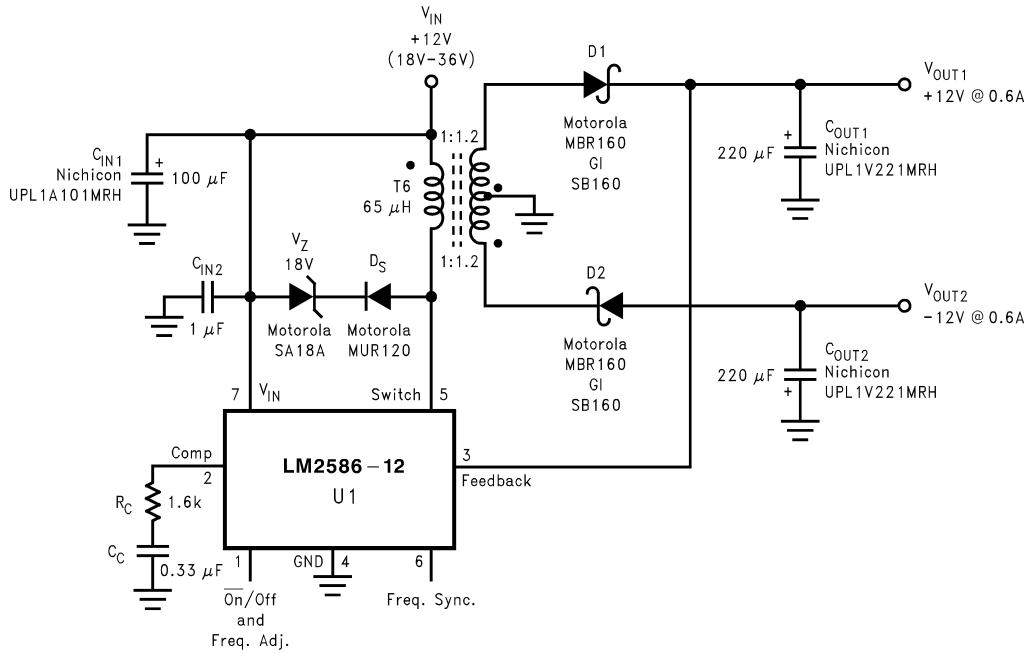

Figure 29. Dual-Output Flyback Regulator

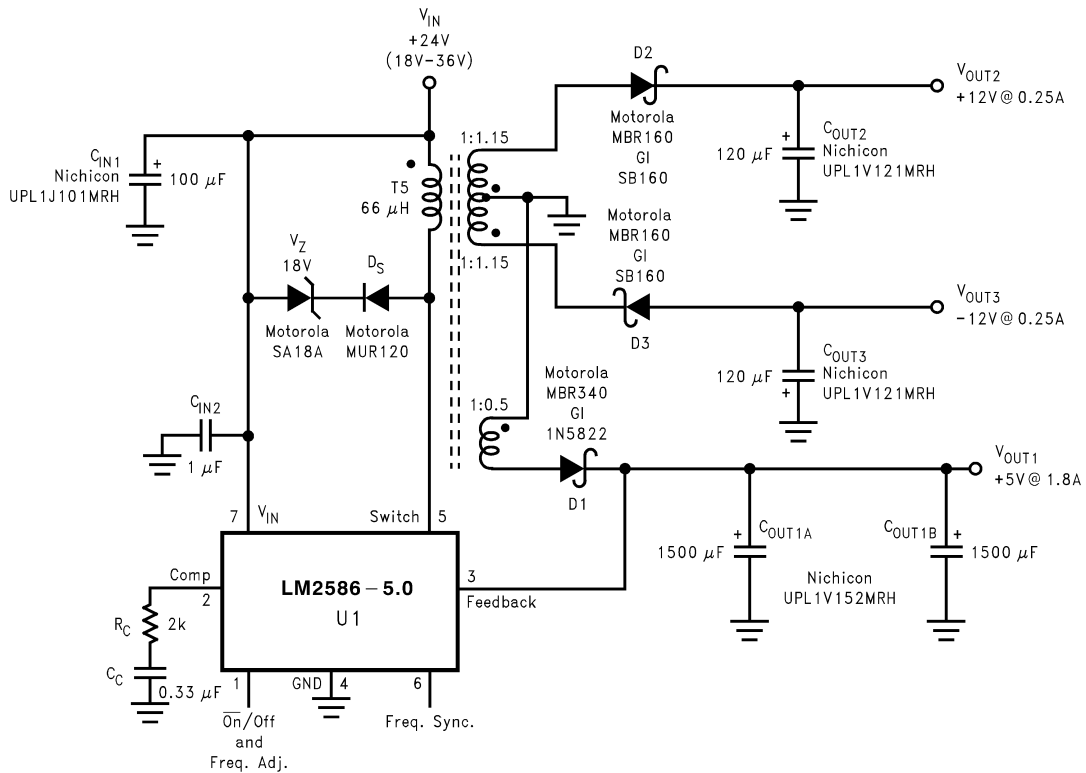

Figure 30. Triple-Output Flyback Regulator

TRANSFORMER SELECTION (T)

Table 1 lists the standard transformers available for flyback regulator applications. Included in the table are the turns ratio(s) for each transformer, as well as the output voltages, input voltage ranges, and the maximum load currents for each circuit.

Table 1. Transformer Selection Table

| Applications | Figure 25 | Figure 26 | Figure 27 | Figure 28 | Figure 29 | Figure 30 |
|-------------------------|-----------|-----------|-----------|-----------|-----------|-----------|
| Transformers | T7 | T7 | T7 | T6 | T6 | T5 |
| V _{IN} | 4V–6V | 4V–6V | 8V–16V | 4V–6V | 18V–36V | 18V–36V |
| V _{OUT1} | 3.3V | 5V | 12V | 12V | 12V | 5V |
| I _{OUT1} (Max) | 1.4A | 1A | 0.8A | 0.15A | 0.6A | 1.8A |
| N ₁ | 1 | 1 | 1 | 1.2 | 1.2 | 0.5 |
| V _{OUT2} | | | | –12V | –12V | 12V |
| I _{OUT2} (Max) | | | | 0.15A | 0.6A | 0.25A |
| N ₂ | | | | 1.2 | 1.2 | 1.15 |
| V _{OUT3} | | | | | | –12V |
| I _{OUT3} (Max) | | | | | | 0.25A |
| N ₃ | | | | | | 1.15 |

Table 2. Transformer Manufacturer Guide

| Transformer Type | Manufacturers' Part Numbers | | | | | |
|------------------|-----------------------------|---|---------------------------------------|----------------------|----------------------|-----------------------|
| | Coilcraft ⁽¹⁾ | Coilcraft ⁽¹⁾ Surface Mount | Pulse ⁽²⁾ Surface Mount | Pulse ⁽²⁾ | Renco ⁽³⁾ | Schott ⁽⁴⁾ |
| T5 | Q4338-B | Q4437-B | PE-68413 | — | RL-5532 | 67140890 |
| T6 | Q4339-B | Q4438-B | PE-68414 | — | RL-5533 | 67140900 |
| T7 | S6000-A | S6057-A | — | PE-68482 | RL-5751 | 26606 |

- (1) Coilcraft Inc., Phone: (800) 322-2645
1102 Silver Lake Road, Cary, IL 60013 Fax: (708) 639-1469
European Headquarters, 21 Napier Place Phone: +44 1236 730 595
Wardpark North, Cumbernauld, Scotland G68 0LL Fax: +44 1236 730 627
- (2) Pulse Engineering Inc., Phone: (619) 674-8100
12220 World Trade Drive, San Diego, CA 92128 Fax: (619) 674 -8262
European Headquarters, Dunmore Road Phone: +353 93 24 107
Tuam, Co. Galway, Ireland Fax: +353 93 24 459
- (3) Renco Electronics Inc., Phone: (800) 645-5828
60 Jeffryn Blvd. East, Deer Park, NY 11729 Fax: (516) 586-5562
- (4) Schott Corp., Phone: (612) 475-1173
1000 Parkers Lane Road, Wayzata, MN 55391 Fax: (612) 475-1786

TRANSFORMER FOOTPRINTS

Figure 31 through Figure 45 show the footprints of each transformer, listed in Table 2.

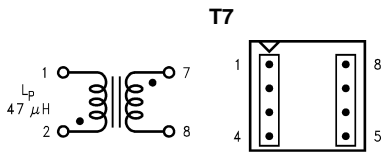

Figure 31. Coilcraft S6000-A (Top View)

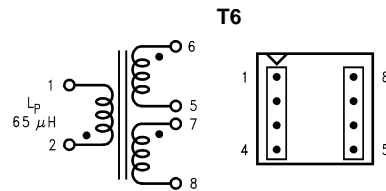

Figure 32. Coilcraft Q4339-B (Top View)

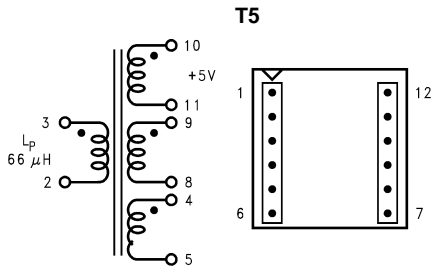

Figure 33. Coilcraft Q4437-B (Surface Mount) (Top View)

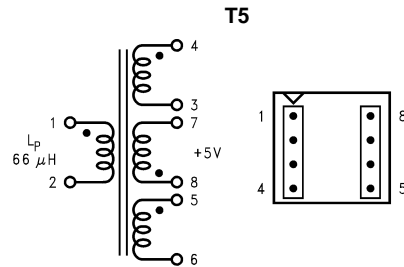

Figure 34. Coilcraft Q4338-B (Top View)

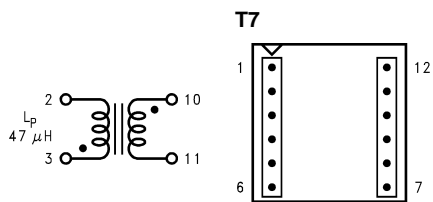

Figure 35. Coilcraft S6057-A (Surface Mount) (Top View)

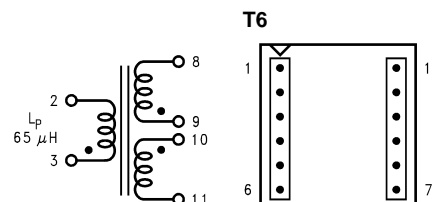

Figure 36. Coilcraft Q4438-B (Surface Mount) (Top View)

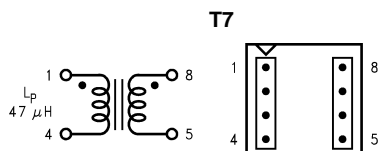

Figure 37. Pulse PE-68482 (Top View)

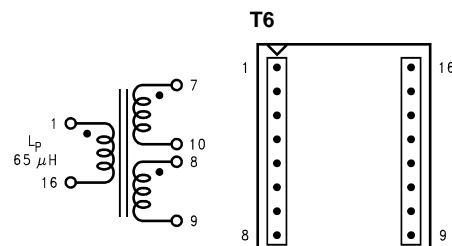

Figure 38. Pulse PE-68414 (Surface Mount) (Top View)

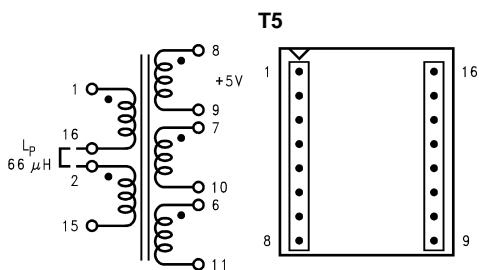

Figure 39. Pulse PE-68413 (Surface Mount) (Top View)

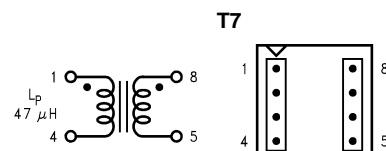

Figure 40. Renco RL-5751 (Top View)

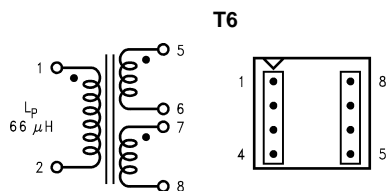

Figure 41. Renco RL-5533 (Top View)

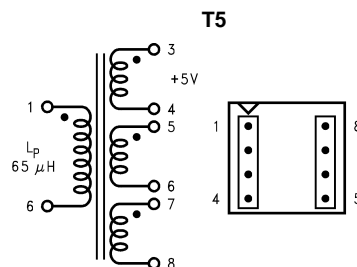

Figure 42. Renco RL-5532 (Top View)

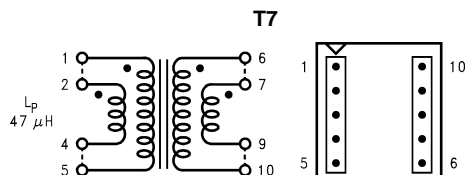

Figure 43. Schott 26606 (Top View)

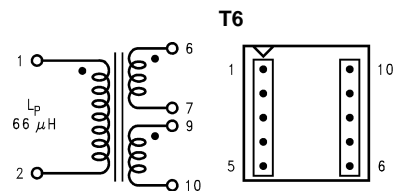

Figure 44. Schott 67140900 (Top View)

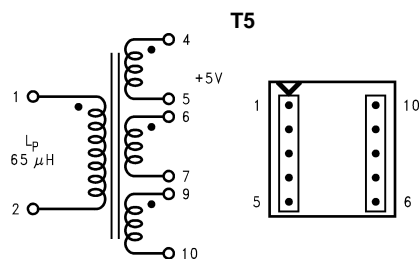

Figure 45. Schott 67140890 (Top View)

Step-Up (Boost) Regulator Operation

Figure 46 shows the LM2586 used as a step-up (boost) regulator. This is a switching regulator that produces an output voltage greater than the input supply voltage.

A brief explanation of how the LM2586 Boost Regulator works is as follows (refer to Figure 46). When the NPN switch turns on, the inductor current ramps up at the rate of V_{IN}/L , storing energy in the inductor. When the switch turns off, the lower end of the inductor flies above V_{IN} , discharging its current through diode (D) into the output capacitor (C_{OUT}) at a rate of $(V_{OUT} - V_{IN})/L$. Thus, energy stored in the inductor during the switch on time is transferred to the output during the switch off time. The output voltage is controlled by adjusting the peak switch current, as described in [Flyback Regulator](#).

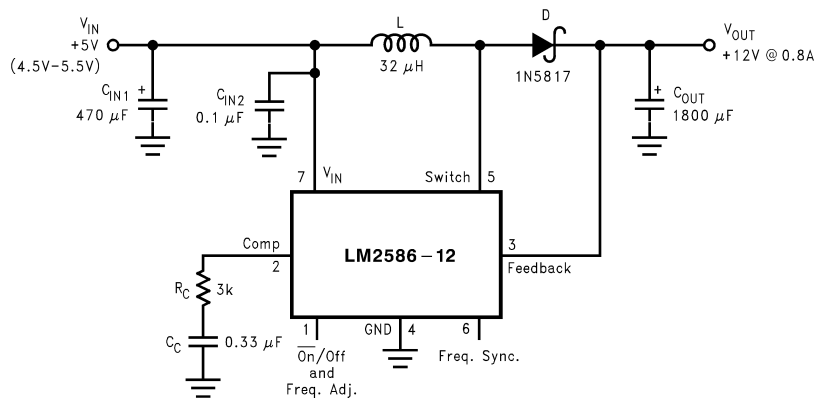

Figure 46. 12V Boost Regulator

By adding a small number of external components (as shown in Figure 46), the LM2586 can be used to produce a regulated output voltage that is greater than the applied input voltage. The switching waveforms observed during the operation of this circuit are shown in Figure 47. Typical performance of this regulator is shown in Figure 48.

Typical Performance Characteristics

- A: Switch Voltage, 10V/div
- B: Switch Current, 2A/div
- C: Inductor Current, 2A/div
- D: Output Ripple Voltage, 100 mV/div, AC-Coupled

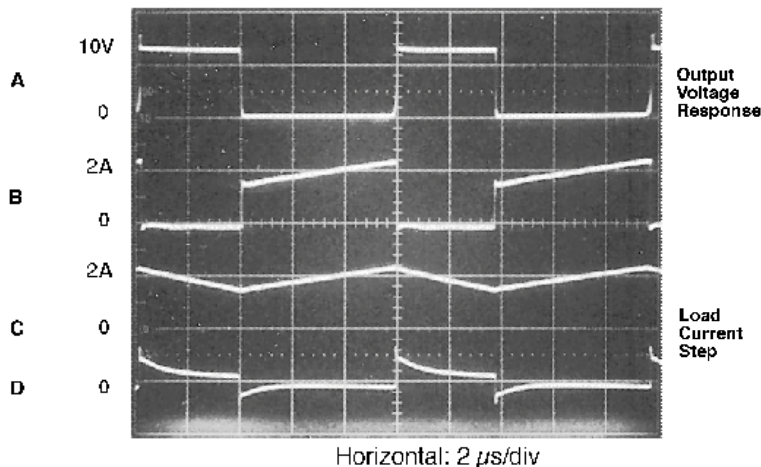

Figure 47. Switching Waveforms

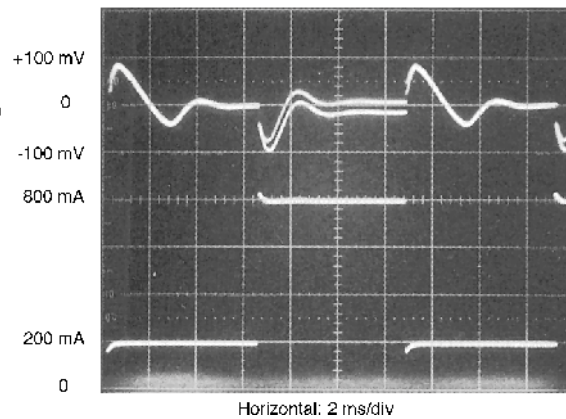

Figure 48. V_{OUT} Response to Load Current Step

Typical Boost Regulator Applications

Figure 49 through Figure 52 show four typical boost applications—one fixed and three using the adjustable version of the LM2586. Each drawing contains the part number(s) and manufacturer(s) for every component. For the fixed 12V output application, the part numbers and manufacturers' names for the inductor are listed in Table 3. For applications with different output voltages, refer to the **Switchers Made Simple** software.

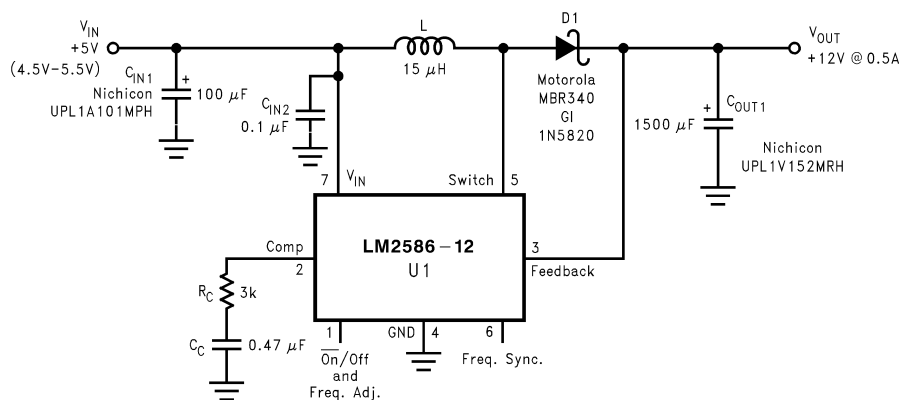

Figure 49. +5V to +12V Boost Regulator

Table 3 contains a list of standard inductors, by part number and corresponding manufacturer, for the fixed output regulator of Figure 49.

Table 3. Inductor Selection Table

| Coilcraft (1) | Pulse (2) | Renco (3) | Schott (4) | Schott (4) (Surface Mount) |
|------------------|--------------|--------------|---------------|----------------------------------|
| DO3316-153 | PE-53898 | RL-5471-7 | 67146510 | 67146540 |

- (1) Coilcraft Inc., Phone: (800) 322-2645
1102 Silver Lake Road, Cary, IL 60013 Fax: (708) 639-1469
European Headquarters, 21 Napier Place Phone: +44 1236 730 595
Wardpark North, Cumbernauld, Scotland G68 0LL Fax: +44 1236 730 627
- (2) Pulse Engineering Inc., Phone: (619) 674-8100
12220 World Trade Drive, San Diego, CA 92128 Fax: (619) 674 -8262
European Headquarters, Dunmore Road Phone: +353 93 24 107
Tuam, Co. Galway, Ireland Fax: +353 93 24 459
- (3) Renco Electronics Inc., Phone: (800) 645-5828
60 Jeffryn Blvd. East, Deer Park, NY 11729 Fax: (516) 586-5562
- (4) Schott Corp., Phone: (612) 475-1173
1000 Parkers Lane Road, Wayzata, MN 55391 Fax: (612) 475-1786

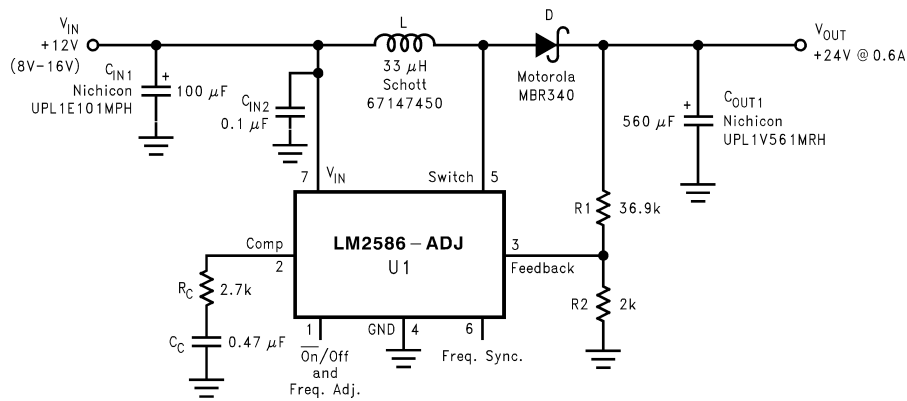

Figure 50. +12V to +24V Boost Regulator

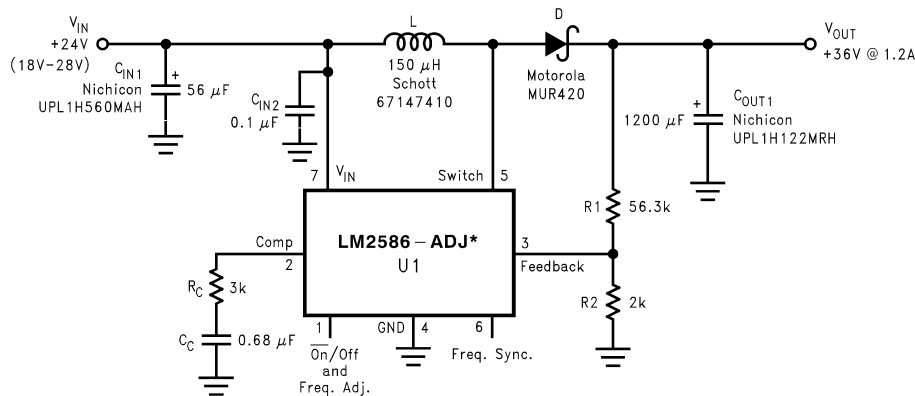

Figure 51. +24V to +36V Boost Regulator

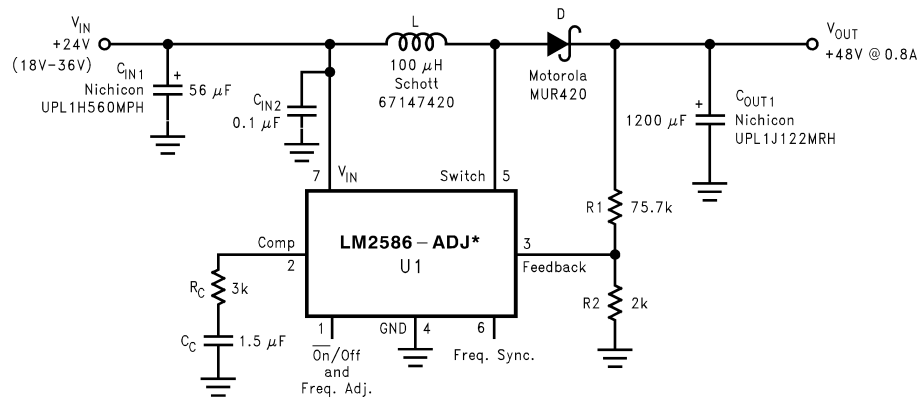

Figure 52. +24V to +48V Boost Regulator

- (1) The LM2586 will require a heat sink in these applications. The size of the heat sink will depend on the maximum ambient temperature. To calculate the thermal resistance of the IC and the size of the heat sink needed, see the [HEAT SINK/THERMAL CONSIDERATIONS](#) section in the [Application Hints](#).

APPLICATION HINTS

LM2586 SPECIAL FEATURES

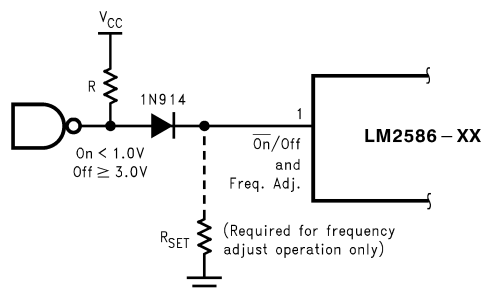

Figure 53. Shutdown Operation

SHUTDOWN CONTROL

A feature of the LM2586 is its ability to be shut down using the $\overline{\text{ON}}/\text{OFF}$ pin (pin 1). This feature conserves input power by turning off the device when it is not in use. For proper operation, an isolation diode is required (as shown in Figure 53).

The device will shut down when 3V or greater is applied on the $\overline{\text{ON}}/\text{OFF}$ pin, sourcing current into pin 1. In shut down mode, the device will draw typically 56 μA of supply current (16 μA to V_{IN} and 40 μA to the $\overline{\text{ON}}/\text{OFF}$ pin). To turn the device back on, leave pin 1 floating, using an (isolation) diode, as shown in Figure 53 (for normal operation, do not source or sink current to or from this pin—see the next section).

FREQUENCY ADJUSTMENT

The switching frequency of the LM2586 can be adjusted with the use of an external resistor. This feature allows the user to optimize the size of the magnetics and the output capacitor(s) by tailoring the operating frequency. A resistor connected from pin 1 (the Freq. Adj. pin) to ground will set the switching frequency from 100 kHz to 200 kHz (maximum). As shown in Figure 53, the pin can be used to adjust the frequency while still providing the shut down function. A curve in Typical Performance Characteristics the resistor value to the corresponding switching frequency. Table 4 shows resistor values corresponding to commonly used frequencies.

However, changing the LM2586's operating frequency from its nominal value of 100 kHz will change the magnetics selection and compensation component values.

Table 4. Frequency Setting Resistor Guide

| $R_{\text{SET}}(\text{k}\Omega)$ | Frequency (kHz) |
|----------------------------------|-----------------|
| Open | 100 |
| 200 | 125 |
| 47 | 150 |
| 33 | 175 |
| 22 | 200 |

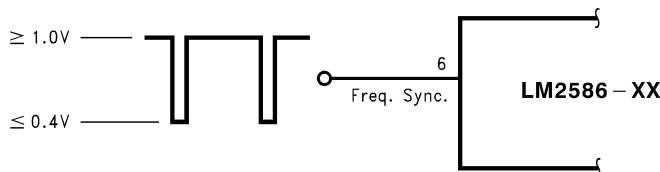

Figure 54. Frequency Synchronization

FREQUENCY SYNCHRONIZATION

Another feature of the LM2586 is the ability to synchronize the switching frequency to an external source, using the sync pin (pin 6). This feature allows the user to parallel multiple devices to deliver more output power.

A negative falling pulse applied to the sync pin will synchronize the LM2586 to an external oscillator (see [Figure 54](#) and [Figure 55](#)).

Use of this feature enables the LM2586 to be synchronized to an external oscillator, such as a system clock. This operation allows multiple power supplies to operate at the same frequency, thus eliminating frequency-related noise problems.

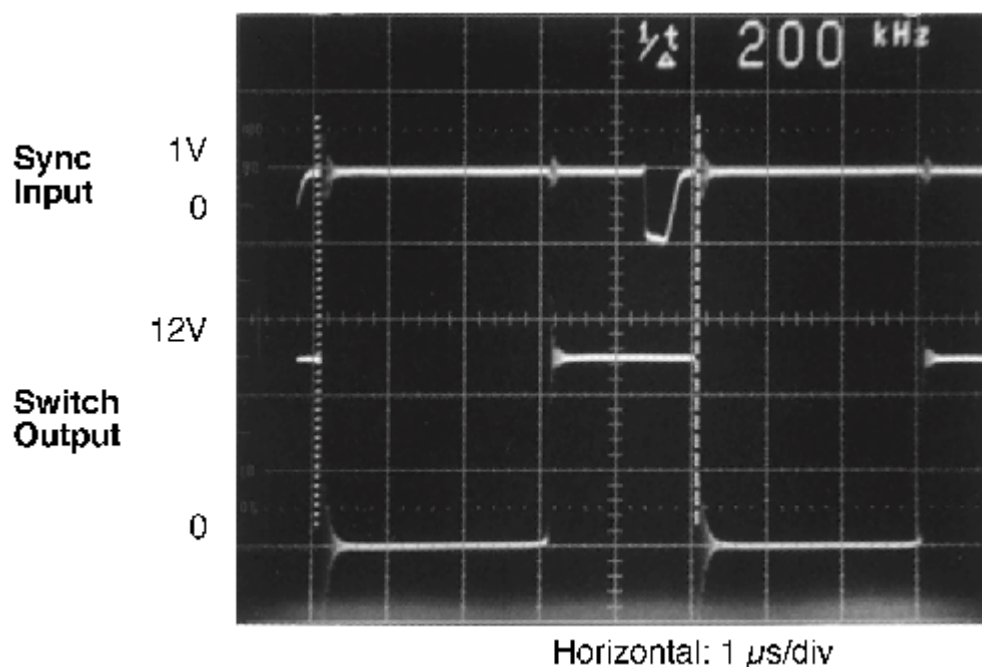

Figure 55. Waveforms of a Synchronized 12V Boost Regulator

The scope photo in [Figure 55](#) shows a LM2586 12V Boost Regulator synchronized to a 200 kHz signal. There is a 700 ns delay between the falling edge of the sync signal and the turning on of the switch.

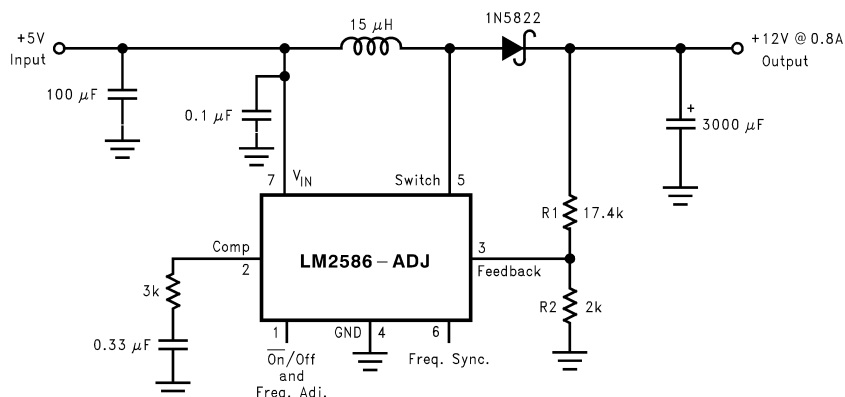

Figure 56. Boost Regulator

PROGRAMMING OUTPUT VOLTAGE (SELECTING R1 AND R2)

Referring to the adjustable regulator in [Figure 56](#), the output voltage is programmed by the resistors R1 and R2 by the following formula:

$$V_{OUT} = V_{REF} (1 + R1/R2)$$

where

- $V_{REF} = 1.23V$ (1)

Resistors R1 and R2 divide the output voltage down so that it can be compared with the 1.23V internal reference. With R2 between 1k and 5k, R1 is:

$$R1 = R2 (V_{OUT}/V_{REF} - 1)$$

where

- $V_{REF} = 1.23V$ (2)

For best temperature coefficient and stability with time, use 1% metal film resistors.

SHORT CIRCUIT CONDITION

Due to the inherent nature of boost regulators, when the output is shorted (see [Figure 56](#)), current flows directly from the input, through the inductor and the diode, to the output, bypassing the switch. The current limit of the switch *does not* limit the output current for the entire circuit. To protect the load and prevent damage to the switch, the current must be externally limited, either by the input supply or at the output with an external current limit circuit. The external limit should be set to the maximum switch current of the device, which is 3A.

In a flyback regulator application ([Figure 57](#)), using the standard transformers, the LM2586 will survive a short circuit to the main output. When the output voltage drops to 80% of its nominal value, the frequency will drop to 25 kHz. With a lower frequency, off times are larger. With the longer off times, the transformer can release all of its stored energy before the switch turns back on. Hence, the switch turns on initially with zero current at its collector. In this condition, the switch current limit will limit the peak current, saving the device.

FLYBACK REGULATOR INPUT CAPACITORS

A flyback regulator draws discontinuous pulses of current from the input supply. Therefore, there are two input capacitors needed in a flyback regulator—one for energy storage and one for filtering (see [Figure 57](#)). Both are required due to the inherent operation of a flyback regulator. To keep a stable or constant voltage supply to the LM2586, a storage capacitor ($\geq 100 \mu F$) is required. If the input source is a rectified DC supply and/or the application has a wide temperature range, the required rms current rating of the capacitor might be very large. This means a larger value of capacitance or a higher voltage rating will be needed for the input capacitor. The storage capacitor will also attenuate noise which may interfere with other circuits connected to the same input supply voltage.

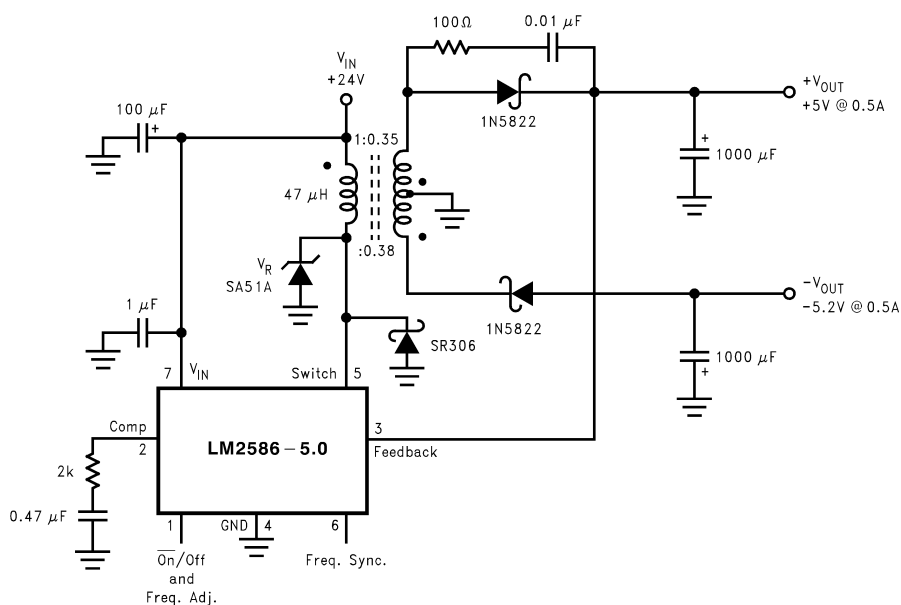

Figure 57. Flyback Regulator

In addition, a small bypass capacitor is required due to the noise generated by the input current pulses. To eliminate the noise, insert a 1.0 μF ceramic capacitor between V_{IN} and ground as close as possible to the device.

SWITCH VOLTAGE LIMITS

In a flyback regulator, the maximum steady-state voltage appearing at the switch, when it is off, is set by the transformer turns ratio, N , the output voltage, V_{OUT} , and the maximum input voltage, $V_{\text{IN}}(\text{Max})$:

$$V_{\text{SW(OFF)}} = V_{\text{IN}}(\text{Max}) + (V_{\text{OUT}} + V_{\text{F}})/N$$

where

- V_{F} is the forward biased voltage of the output diode, and is typically 0.5V for Schottky diodes and 0.8V for ultra-fast recovery diodes (3)

In certain circuits, there exists a voltage spike, V_{LL} , superimposed on top of the steady-state voltage (see [Figure 23](#), waveform A). Usually, this voltage spike is caused by the transformer leakage inductance and/or the output rectifier recovery time. To “clamp” the voltage at the switch from exceeding its maximum value, a transient suppressor in series with a diode is inserted across the transformer primary (as shown in the circuit in [Figure 22](#) and other flyback regulator circuits throughout the datasheet). The schematic in [Figure 57](#) shows another method of clamping the switch voltage. A single voltage transient suppressor (the SA51A) is inserted at the switch pin. This method clamps the total voltage across the switch, not just the voltage across the primary.

If poor circuit layout techniques are used (see the [Circuit Layout Guideline](#) section), negative voltage transients may appear on the Switch pin (pin 5). Applying a negative voltage (with respect to the IC's ground) to any monolithic IC pin causes erratic and unpredictable operation of that IC. This holds true for the LM2586 IC as well. When used in a flyback regulator, the voltage at the Switch pin (pin 5) can go negative when the switch turns on. The “ringing” voltage at the switch pin is caused by the output diode capacitance and the transformer leakage inductance forming a resonant circuit at the secondary(ies). The resonant circuit generates the “ringing” voltage, which gets reflected back through the transformer to the switch pin. There are two common methods to avoid this problem. One is to add an RC snubber around the output rectifier(s), as in [Figure 57](#). The values of the resistor and the capacitor must be chosen so that the voltage at the Switch pin does not drop below -0.4V . The resistor may range in value between 10Ω and $1\text{k}\Omega$, and the capacitor will vary from $0.001\ \mu\text{F}$ to $0.1\ \mu\text{F}$. Adding a snubber will (slightly) reduce the efficiency of the overall circuit.

The other method to reduce or eliminate the “ringing” is to insert a Schottky diode clamp between pins 5 and 4 (ground), also shown in [Figure 57](#). This prevents the voltage at pin 5 from dropping below -0.4V . The reverse voltage rating of the diode must be greater than the switch off voltage.

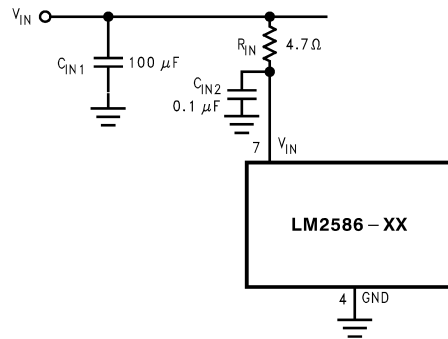

Figure 58. Input Line Filter

OUTPUT VOLTAGE LIMITATIONS

The maximum output voltage of a boost regulator is the maximum switch voltage minus a diode drop. In a flyback regulator, the maximum output voltage is determined by the turns ratio, N , and the duty cycle, D , by the equation:

$$V_{OUT} \approx N \times V_{IN} \times D / (1 - D) \quad (4)$$

The duty cycle of a flyback regulator is determined by the following equation:

$$D = \frac{V_{OUT} + V_F}{N(V_{IN} - V_{SAT}) + V_{OUT} + V_F} \approx \frac{V_{OUT}}{N(V_{IN}) + V_{OUT}} \quad (5)$$

Theoretically, the maximum output voltage can be as large as desired—just keep increasing the turns ratio of the transformer. However, there exists some physical limitations that prevent the turns ratio, and thus the output voltage, from increasing to infinity. The physical limitations are capacitances and inductances in the LM2586 switch, the output diode(s), and the transformer—such as reverse recovery time of the output diode (mentioned above).

NOISY INPUT LINE CONDITION

A small, low-pass RC filter should be used at the input pin of the LM2586 if the input voltage has an unusually large amount of transient noise, such as with an input switch that bounces. The circuit in [Figure 58](#) demonstrates the layout of the filter, with the capacitor placed from the input pin to ground and the resistor placed between the input supply and the input pin. Note that the values of R_{IN} and C_{IN} shown in the schematic are good enough for most applications, but some readjusting might be required for a particular application. If efficiency is a major concern, replace the resistor with a small inductor (say 10 μ H and rated at 200 mA).

STABILITY

All current-mode controlled regulators can suffer from an instability, known as subharmonic oscillation, if they operate with a duty cycle above 50%. To eliminate subharmonic oscillations, a minimum value of inductance is required to ensure stability for all boost and flyback regulators. The minimum inductance is given by:

$$L(\text{Min}) = \frac{2.92 [(V_{IN}(\text{Min}) - V_{SAT}) \cdot (2D(\text{Max}) - 1)]}{1 - D(\text{Max})} (\mu\text{H})$$

where

- V_{SAT} is the switch saturation voltage and can be found in the Characteristic Curves (6)

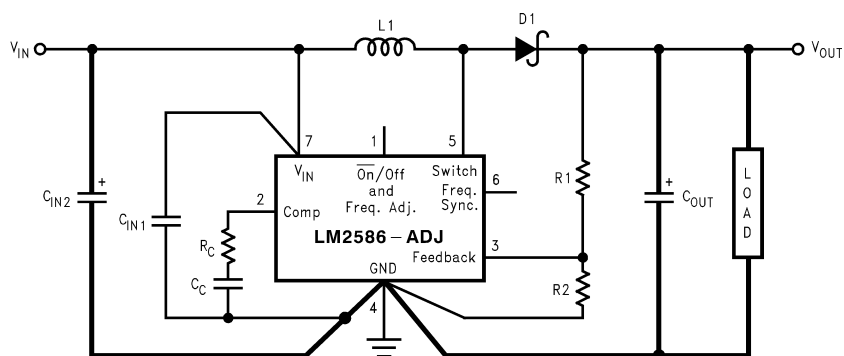

Figure 59. Circuit Board Layout

CIRCUIT LAYOUT GUIDELINES

As in any switching regulator, layout is very important. Rapidly switching currents associated with wiring inductance generate voltage transients which can cause problems. For minimal inductance and ground loops, keep the length of the leads and traces as short as possible. Use single point grounding or ground plane construction for best results. Separate the signal grounds from the power grounds (as indicated in Figure 59). When using the Adjustable version, physically locate the programming resistors as near the regulator IC as possible, to keep the sensitive feedback wiring short.

HEAT SINK/THERMAL CONSIDERATIONS

In many cases, a heat sink is not required to keep the LM2586 junction temperature within the allowed operating temperature range. For each application, to determine whether or not a heat sink will be required, the following must be identified:

- 1) Maximum ambient temperature (in the application).
- 2) Maximum regulator power dissipation (in the application).
- 3) Maximum allowed junction temperature (125°C for the LM2586). For a safe, conservative design, a temperature approximately 15°C cooler than the maximum junction temperature should be selected (110°C).
- 4) LM2586 package thermal resistances θ_{JA} and θ_{JC} (given in the Electrical Characteristics).

Total power dissipated (P_D) by the LM2586 can be estimated as follows:

Boost:

$$P_D = 0.15\Omega \cdot \left(\frac{I_{LOAD}}{1-D} \right)^2 \cdot D + \frac{I_{LOAD}}{50 \cdot (1-D)} \cdot D \cdot V_{IN}$$

Flyback:

$$P_D = 0.15\Omega \cdot \left(\frac{N \cdot \sum I_{LOAD}}{1-D} \right)^2 \cdot D + \frac{N \cdot \sum I_{LOAD}}{50 \cdot (1-D)} \cdot D \cdot V_{IN}$$

where

- V_{IN} is the minimum input voltage
- V_{OUT} is the output voltage
- N is the transformer turns ratio, D is the duty cycle
- I_{LOAD} is the maximum load current (and $\sum I_{LOAD}$ is the sum of the maximum load currents for multiple-output flyback regulators)

(7)

The duty cycle is given by:

Boost:

$$D = \frac{V_{OUT} + V_F - V_{IN}}{V_{OUT} + V_F - V_{SAT}} \approx \frac{V_{OUT} - V_{IN}}{V_{OUT}}$$

Flyback:

$$D = \frac{V_{OUT} + V_F}{N(V_{IN} - V_{SAT}) + V_{OUT} + V_F} \approx \frac{V_{OUT}}{N(V_{IN}) + V_{OUT}}$$

where

- V_F is the forward biased voltage of the diode and is typically 0.5V for Schottky diodes and 0.8V for fast recovery diodes
- V_{SAT} is the switch saturation voltage and can be found in the Characteristic Curves (8)

When no heat sink is used, the junction temperature rise is:

$$\Delta T_J = P_D \cdot \theta_{JA} \quad (9)$$

Adding the junction temperature rise to the maximum ambient temperature gives the actual operating junction temperature:

$$T_J = \Delta T_J + T_A \quad (10)$$

If the operating junction temperature exceeds the maximum junction temperature in item 3 above, then a heat sink is required. When using a heat sink, the junction temperature rise can be determined by the following:

$$\Delta T_J = P_D \cdot (\theta_{JC} + \theta_{Interface} + \theta_{Heat\ Sink}) \quad (11)$$

Again, the operating junction temperature will be:

$$T_J = \Delta T_J + T_A \quad (12)$$

As before, if the maximum junction temperature is exceeded, a larger heat sink is required (one that has a lower thermal resistance).

Included in the **Switchers Made Simple**[®] design software is a more precise (non-linear) thermal model that can be used to determine junction temperature with different input-output parameters or different component values. It can also calculate the heat sink thermal resistance required to maintain the regulator junction temperature below the maximum operating temperature.

*To further simplify the flyback regulator design procedure, Texas Instruments is making available computer design software to be used with the Simple Switcher[®] line of switching regulators. **Switchers Made Simple** is available on a 3½" diskette for IBM compatible computers from a Texas Instruments sales office in your area or the Texas Instruments Customer Response Center ((800) 477-8924).*

REVISION HISTORY

| Changes from Revision C (April 2013) to Revision D | Page |
|--|--------------------|
| • Changed layout of National Data Sheet to TI format | 30 |

PACKAGE OPTION ADDENDUM

1-Nov-2013

PACKAGING INFORMATION

| Orderable Device | Status (1) | Package Type | Package Drawing | Pins | Package Qty | Eco Plan (2) | Lead/Ball Finish (6) | MSL Peak Temp (3) | Op Temp (°C) | Device Marking (4/5) | Samples |
|-------------------|---------------|------------------|-----------------|------|-------------|--------------------------|-------------------------|----------------------|--------------|-------------------------|-------------------------|
| LM2586S-12/NOPB | ACTIVE | DDPAK/ TO-263 | KTW | 7 | 45 | Pb-Free (RoHS Exempt) | CU SN | Level-3-245C-168 HR | -40 to 125 | LM2586S -12 P+ | Samples |
| LM2586S-3.3/NOPB | ACTIVE | DDPAK/ TO-263 | KTW | 7 | 45 | Pb-Free (RoHS Exempt) | CU SN | Level-3-245C-168 HR | -40 to 125 | LM2586S -3.3 P+ | Samples |
| LM2586S-5.0/NOPB | ACTIVE | DDPAK/ TO-263 | KTW | 7 | 45 | Pb-Free (RoHS Exempt) | CU SN | Level-3-245C-168 HR | -40 to 125 | LM2586S -5.0 P+ | Samples |
| LM2586S-ADJ | NRND | DDPAK/ TO-263 | KTW | 7 | 45 | TBD | Call TI | Call TI | -40 to 125 | LM2586S -ADJ P+ | |
| LM2586S-ADJ/NOPB | ACTIVE | DDPAK/ TO-263 | KTW | 7 | 45 | Pb-Free (RoHS Exempt) | CU SN | Level-3-245C-168 HR | -40 to 125 | LM2586S -ADJ P+ | Samples |
| LM2586SX-3.3/NOPB | ACTIVE | DDPAK/ TO-263 | KTW | 7 | 500 | Pb-Free (RoHS Exempt) | CU SN | Level-3-245C-168 HR | -40 to 125 | LM2586S -3.3 P+ | Samples |
| LM2586SX-5.0/NOPB | ACTIVE | DDPAK/ TO-263 | KTW | 7 | 500 | Pb-Free (RoHS Exempt) | CU SN | Level-3-245C-168 HR | -40 to 125 | LM2586S -5.0 P+ | Samples |
| LM2586SX-ADJ | NRND | DDPAK/ TO-263 | KTW | 7 | 500 | TBD | Call TI | Call TI | -40 to 125 | LM2586S -ADJ P+ | |
| LM2586SX-ADJ/NOPB | ACTIVE | DDPAK/ TO-263 | KTW | 7 | 500 | Pb-Free (RoHS Exempt) | CU SN | Level-3-245C-168 HR | -40 to 125 | LM2586S -ADJ P+ | Samples |
| LM2586T-3.3/NOPB | ACTIVE | TO-220 | NDZ | 7 | 45 | Pb-Free (RoHS Exempt) | CU SN | Level-1-NA-UNLIM | -40 to 125 | LM2586T -3.3 P+ | Samples |
| LM2586T-5.0/NOPB | ACTIVE | TO-220 | NDZ | 7 | 45 | Pb-Free (RoHS Exempt) | CU SN | Level-1-NA-UNLIM | -40 to 125 | LM2586T -5.0 P+ | Samples |
| LM2586T-ADJ | NRND | TO-220 | NDZ | 7 | 45 | TBD | Call TI | Call TI | -40 to 125 | LM2586T -ADJ P+ | |
| LM2586T-ADJ/NOPB | ACTIVE | TO-220 | NDZ | 7 | 45 | Pb-Free (RoHS Exempt) | CU SN | Level-1-NA-UNLIM | -40 to 125 | LM2586T -ADJ P+ | Samples |

(1) The marketing status values are defined as follows:

ACTIVE: Product device recommended for new designs.

LIFEBUY: TI has announced that the device will be discontinued, and a lifetime-buy period is in effect.

NRND: Not recommended for new designs. Device is in production to support existing customers, but TI does not recommend using this part in a new design.

PREVIEW: Device has been announced but is not in production. Samples may or may not be available.

OBSOLETE: TI has discontinued the production of the device.

⁽²⁾ Eco Plan - The planned eco-friendly classification: Pb-Free (RoHS), Pb-Free (RoHS Exempt), or Green (RoHS & no Sb/Br) - please check <http://www.ti.com/productcontent> for the latest availability information and additional product content details.

TBD: The Pb-Free/Green conversion plan has not been defined.

Pb-Free (RoHS): TI's terms "Lead-Free" or "Pb-Free" mean semiconductor products that are compatible with the current RoHS requirements for all 6 substances, including the requirement that lead not exceed 0.1% by weight in homogeneous materials. Where designed to be soldered at high temperatures, TI Pb-Free products are suitable for use in specified lead-free processes.

Pb-Free (RoHS Exempt): This component has a RoHS exemption for either 1) lead-based flip-chip solder bumps used between the die and package, or 2) lead-based die adhesive used between the die and leadframe. The component is otherwise considered Pb-Free (RoHS compatible) as defined above.

Green (RoHS & no Sb/Br): TI defines "Green" to mean Pb-Free (RoHS compatible), and free of Bromine (Br) and Antimony (Sb) based flame retardants (Br or Sb do not exceed 0.1% by weight in homogeneous material)

⁽³⁾ MSL, Peak Temp. - The Moisture Sensitivity Level rating according to the JEDEC industry standard classifications, and peak solder temperature.

⁽⁴⁾ There may be additional marking, which relates to the logo, the lot trace code information, or the environmental category on the device.

⁽⁵⁾ Multiple Device Markings will be inside parentheses. Only one Device Marking contained in parentheses and separated by a "~" will appear on a device. If a line is indented then it is a continuation of the previous line and the two combined represent the entire Device Marking for that device.

⁽⁶⁾ Lead/Ball Finish - Orderable Devices may have multiple material finish options. Finish options are separated by a vertical ruled line. Lead/Ball Finish values may wrap to two lines if the finish value exceeds the maximum column width.

Important Information and Disclaimer: The information provided on this page represents TI's knowledge and belief as of the date that it is provided. TI bases its knowledge and belief on information provided by third parties, and makes no representation or warranty as to the accuracy of such information. Efforts are underway to better integrate information from third parties. TI has taken and continues to take reasonable steps to provide representative and accurate information but may not have conducted destructive testing or chemical analysis on incoming materials and chemicals. TI and TI suppliers consider certain information to be proprietary, and thus CAS numbers and other limited information may not be available for release.

In no event shall TI's liability arising out of such information exceed the total purchase price of the TI part(s) at issue in this document sold by TI to Customer on an annual basis.

TAPE AND REEL INFORMATION

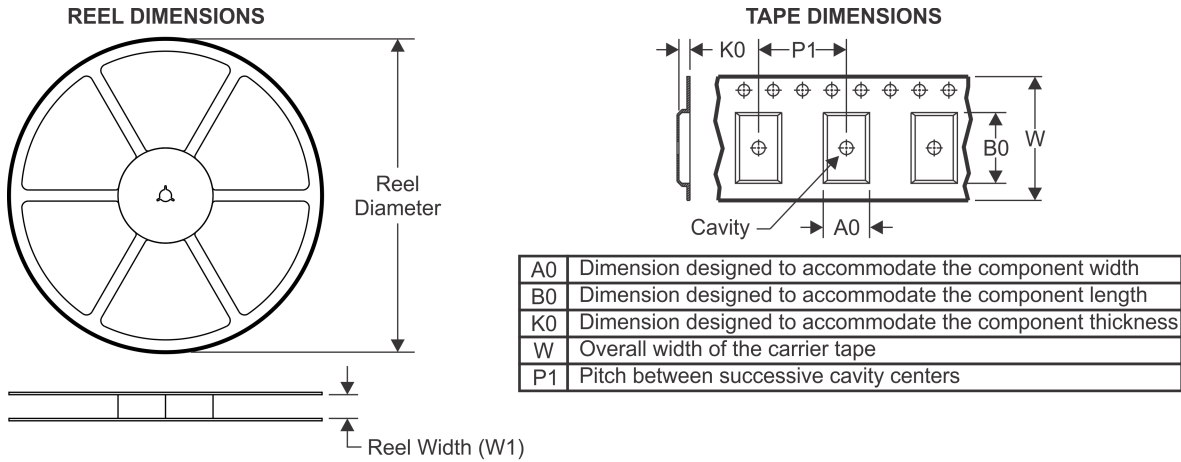

QUADRANT ASSIGNMENTS FOR PIN 1 ORIENTATION IN TAPE

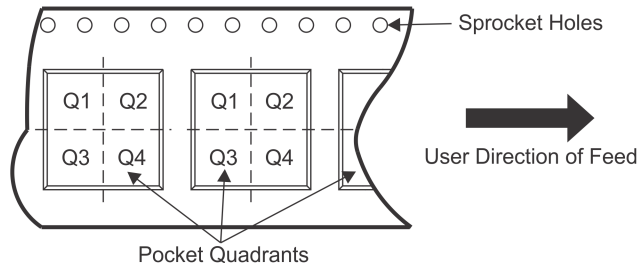

*All dimensions are nominal

| Device | Package Type | Package Drawing | Pins | SPQ | Reel Diameter (mm) | Reel Width W1 (mm) | A0 (mm) | B0 (mm) | K0 (mm) | P1 (mm) | W (mm) | Pin1 Quadrant |
|-------------------|--------------|-----------------|------|-----|--------------------|--------------------|---------|---------|---------|---------|--------|---------------|
| LM2586SX-3.3/NOPB | DDPAK/TO-263 | KTW | 7 | 500 | 330.0 | 24.4 | 10.75 | 14.85 | 5.0 | 16.0 | 24.0 | Q2 |
| LM2586SX-5.0/NOPB | DDPAK/TO-263 | KTW | 7 | 500 | 330.0 | 24.4 | 10.75 | 14.85 | 5.0 | 16.0 | 24.0 | Q2 |
| LM2586SX-ADJ | DDPAK/TO-263 | KTW | 7 | 500 | 330.0 | 24.4 | 10.75 | 14.85 | 5.0 | 16.0 | 24.0 | Q2 |
| LM2586SX-ADJ/NOPB | DDPAK/TO-263 | KTW | 7 | 500 | 330.0 | 24.4 | 10.75 | 14.85 | 5.0 | 16.0 | 24.0 | Q2 |

TAPE AND REEL BOX DIMENSIONS

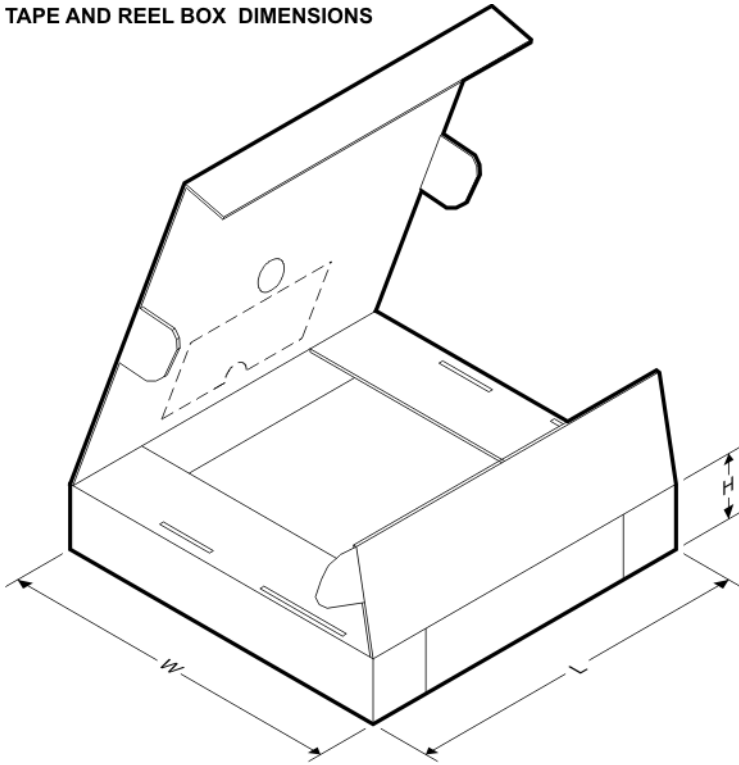

*All dimensions are nominal

| Device | Package Type | Package Drawing | Pins | SPQ | Length (mm) | Width (mm) | Height (mm) |
|-------------------|--------------|-----------------|------|-----|-------------|------------|-------------|
| LM2586SX-3.3/NOPB | DDPAK/TO-263 | KTW | 7 | 500 | 367.0 | 367.0 | 45.0 |
| LM2586SX-5.0/NOPB | DDPAK/TO-263 | KTW | 7 | 500 | 367.0 | 367.0 | 45.0 |
| LM2586SX-ADJ | DDPAK/TO-263 | KTW | 7 | 500 | 367.0 | 367.0 | 45.0 |
| LM2586SX-ADJ/NOPB | DDPAK/TO-263 | KTW | 7 | 500 | 367.0 | 367.0 | 45.0 |

NDZ0007B

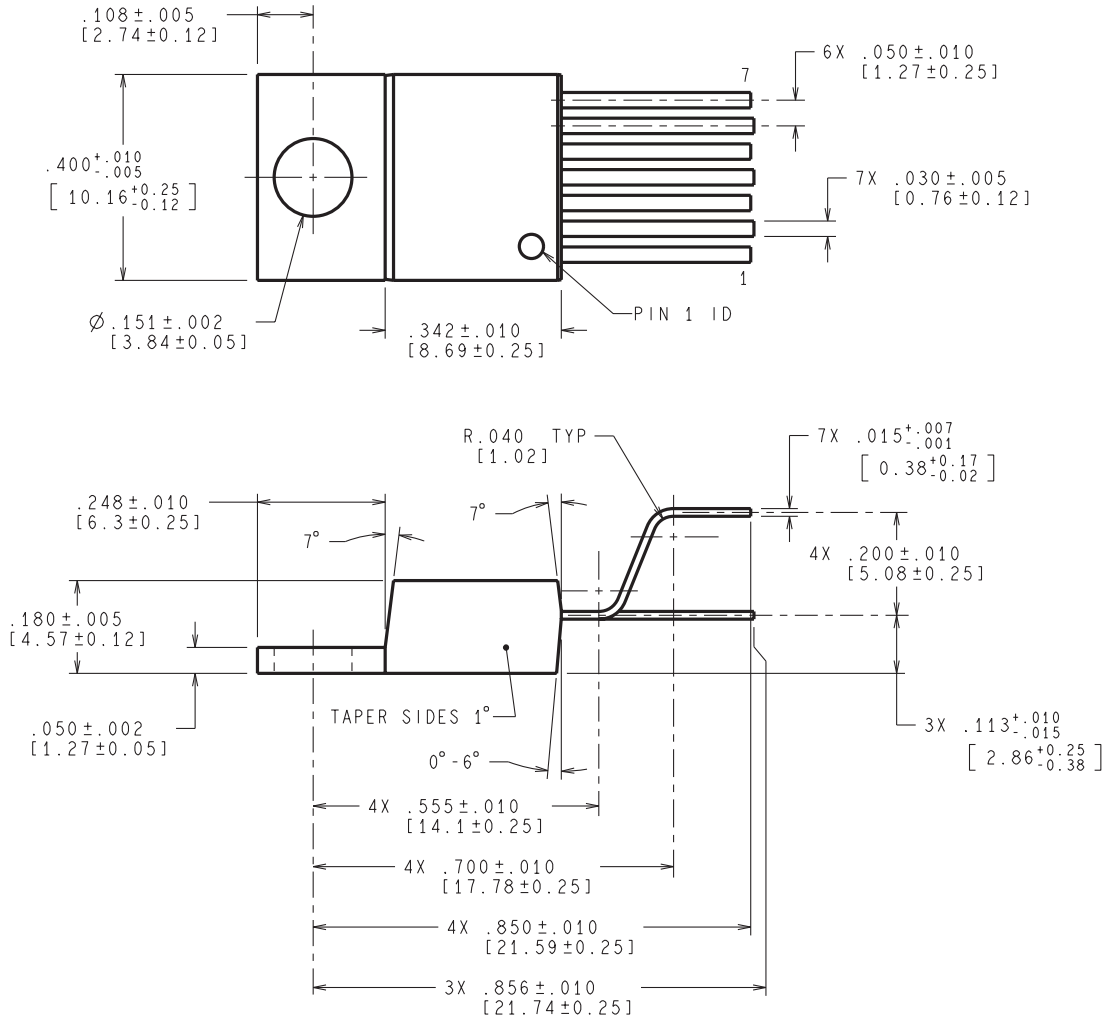

CONTROLLING DIMENSIONS IS INCH
VALUES IN [] ARE MILLIMETERS

TA07B (Rev E)

