

# LM3555 Synchronous Boost Converter with 500 mA High Side LED Driver and Dual-Mode Control Interface

Check for Samples: [LM3555](#)

## FEATURES

- High-Voltage High-Side Current Source Allows for Grounded Cathode LED Operation
- Synchronous Boost Converter
- Peak Converter Efficiency >90%
- Accurate and Programmable LED Current ranging from 60 mA to 500 mA
- Adaptive LED Current Range Based on LED Configuration
- Dedicated Indicator Current Source
- Dedicated Torch and Strobe Pins

- Dual Mode Control (General Purpose or I<sup>2</sup>C)
- Broken Inductor Detection
- Output Over-Voltage Protection
- Output and LED Short-Circuit Protection
- 400kHz I<sup>2</sup>C-Compatible Interface
- 12-Bump, 1.575 mm x 2.1 mm x 0.6 mm micro SMD Package (TLA12BCA)

## APPLICATIONS

- Camera Phone LED Flash

## DESCRIPTION

The LM3555 is a 2 MHz fixed frequency, current mode synchronous boost converter designed to drive either a single flash LED at 500 mA or two series flash LEDs at 400 mA. A high-voltage current source allows the LEDs to be terminated to the GND plane eliminating the need for an additional return trace back to the IC.

A dual mode control interface allows the user to configure the LM3555 with a general-purpose interface using two enable pins for control or an I<sup>2</sup>C allowing a higher level of control. Both interfaces allow access to the indicator, assist light and flash modes. A dedicated Strobe pin provides a direct interface to trigger the flash event, while an external Torch pin provides an additional method for enabling the LEDs in a constant current mode.

The LM3555 can adaptively scale the maximum flash level delivered to the LED/LEDs based upon the flash configuration, whether it be a single LED or two LEDs in series.

Eight protection features are available on the LM3555 ranging from over-voltage protection to broken inductor detection. The LM3555 has four selectable inductor current limits to help the user select an inductor that is appropriate for the design.



Please be aware that an important notice concerning availability, standard warranty, and use in critical applications of Texas Instruments semiconductor products and disclaimers thereto appears at the end of this data sheet.

All trademarks are the property of their respective owners.

### Typical Application Circuits

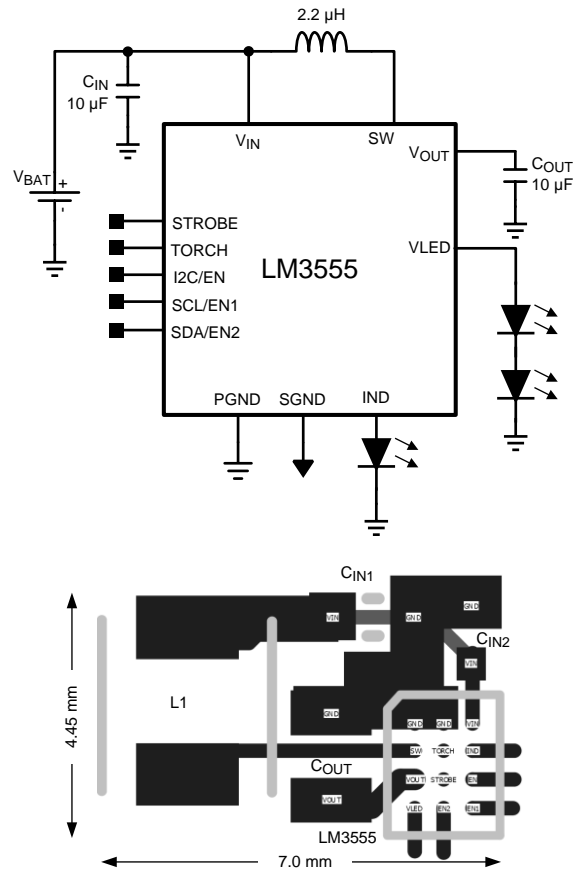

### Connection Diagram

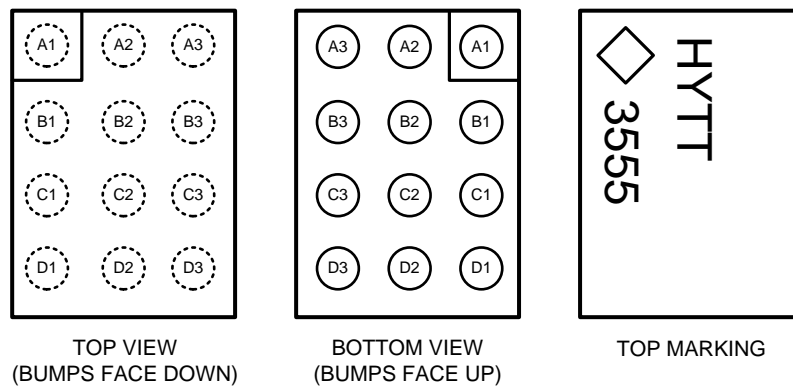

**Note:** The actual physical placement of the package marking will vary from part to part. The package marking "HY" designates the date code. "TT" is a NSC internal code for die traceability. Both will vary considerably. "3555" identifies the device (part number, option, etc.).

### Pin Functions

#### Pin Descriptions

Pin Position	Signal Name	Input / Output (I/O)	Description
A1	PGND		Power ground.
A2	SGND		Signal ground.

**Pin Descriptions (continued)**

A3	VIN	I	Input voltage pin of the device. Connect input bypass capacitor very close to this pin.
B1	SW		Inductor connection.
B2	TORCH	I	Torch pin. Driving this pin high enables Torch mode.
B3	IND	O	Red indicator LED current source. Connect to RED LED anode.
C1	VOUT	O	Boost output. Connect output bypass capacitor very close to this pin.
C2	STROBE	I/O	Strobe signal input pin to synchronize flash pulse in I <sup>2</sup> C mode. This signal usually comes from the camera processor. In Simple logic mode this pin, when tied to a voltage rail through a pull-up resistor indicates the number of LEDs in the system.
C3	I2C / EN	I	I2C / EN-logic selection. High = I <sup>2</sup> C mode, Low = Simple logic mode.
D1	VLED	O	LED current source. Connect to the anode of the Flash LED. One or two LEDs can be connected in series.
D2	SDA / EN2	I/O	EN2 signal pin in Simple logic mode. I <sup>2</sup> C data signal in I <sup>2</sup> C mode.
D3	SCL / EN1	I	EN1 signal pin in Simple logic mode. I <sup>2</sup> C clock signal in I <sup>2</sup> C mode.



These devices have limited built-in ESD protection. The leads should be shorted together or the device placed in conductive foam during storage or handling to prevent electrostatic damage to the MOS gates.

**Absolute Maximum Ratings** <sup>(1) (2)</sup>

VIN	-0.3V to +6V
TORCH, IND, STROBE, I2C/EN, SDA/EN2, SCL/EN1	-0.3V to (VIN+0.3V) w/ 6.0V max.
SW	+12V
VOUT, VLED	+10V
Continuous Power Dissipation <sup>(3)</sup>	Internally Limited
Junction Temperature (T <sub>J-MAX</sub> )	+150°C
Storage Temperature Range	-55°C to +150°C
Maximum Lead Temperature (Soldering)	<sup>(4)</sup>
ESD Rating Human Body Model <sup>(5)</sup>	2.5kV

- (1) Absolute Maximum Ratings indicate limits beyond which damage to the device may occur. Operating Ratings are conditions under which operation of the device is guaranteed. Operating Ratings do not imply guaranteed performance limits. For guaranteed performance limits and associated test conditions, see the Electrical Characteristics tables.
- (2) All voltages are with respect to the potential at the GND pin.
- (3) Internal thermal shutdown circuitry protects the device from permanent damage. Thermal shutdown engages at T<sub>J</sub>=150°C (typ.) and disengages at T<sub>J</sub>=135°C (typ.). Thermal shutdown is guaranteed by design.
- (4) For detailed soldering specifications and information, please refer to Texas Instruments Application Note: AN-1112: Micro SMD Wafer Level Chip Scale Package. For Recommended Soldering Profiles.
- (5) The human body model is a 100 pF capacitor discharged through a 1.5 kΩ resistor into each pin. (MIL-STD-883 3015.7)

**Operating Ratings** <sup>(1) (2)</sup>

Input Voltage Range	2.5 to 5.5V
Junction Temperature Range (T <sub>J</sub> )	-30°C to +125°C
Ambient Temperature Range (T <sub>A</sub> ) <sup>(3)</sup>	-30°C to +85°C

- (1) Absolute Maximum Ratings indicate limits beyond which damage to the device may occur. Operating Ratings are conditions under which operation of the device is guaranteed. Operating Ratings do not imply guaranteed performance limits. For guaranteed performance limits and associated test conditions, see the Electrical Characteristics tables.
- (2) All voltages are with respect to the potential at the GND pin.
- (3) In applications where high power dissipation and/or poor package thermal resistance is present, the maximum ambient temperature may have to be de-rated. Maximum ambient temperature (T<sub>A-MAX</sub>) is dependent on the maximum operating junction temperature (T<sub>J-MAX-OP</sub> = +125°C), the maximum power dissipation of the device in the application (P<sub>D-MAX</sub>), and the junction-to-ambient thermal resistance of the part/package in the application (θ<sub>JA</sub>), as given by the following equation: T<sub>A-MAX</sub> = T<sub>J-MAX-OP</sub> - (θ<sub>JA</sub> × P<sub>D-MAX</sub>).

## Thermal Properties

Thermal Resistance Junction-to-Ambient ( $\theta_{JA}$ ) <sup>(1)</sup>	60°C/W
---	--------

- (1) Junction-to-ambient thermal resistance ( $\theta_{JA}$ ) is taken from a thermal modeling result, performed under the conditions and guidelines set forth in the JEDEC standard JESD51-7. The test board is a 4-layer FR-4 board measuring 102mm x 76mm x 1.6mm with a 2x1 array of thermal vias. The ground plane on the board is 50mm x 50mm. Thickness of copper layers are 36 $\mu$ m/18 $\mu$ m/18 $\mu$ m/3 $\mu$ m (1.5oz/1oz/1oz/1.5oz). Ambient temperature in simulation is 22°C, still air. Power dissipation is 1W.

## Electrical Characteristics

Limits in standard typeface are for  $T_A = +25^\circ\text{C}$ . Limits in **boldface** type apply over the full operating ambient temperature range ( $-30^\circ\text{C} \leq T_A \leq +85^\circ\text{C}$ ). Unless otherwise specified:  $V_{IN} = 3.6\text{V}$ .<sup>(1) (2)</sup>

Symbol	Parameter	Conditions		Min	Typ	Max	Units
<b>CURRENT AND VOLTAGE SPECIFICATIONS</b>							
$I_{LED-OUT}$	Flash LED Accuracy	$2.7\text{V} \leq V_{IN} \leq 5.5\text{V}$ $V_{OUT} = 6.5\text{V}$ , $V_{LED} = 6.2\text{V}$		<b>50.7</b> <b>(-15.5%)</b>	60	<b>67.2</b> <b>(+12%)</b>	mA (%)
				<b>69.8</b> <b>(-12.8%)</b>	80	<b>86.4</b> <b>(+8.0%)</b>	
				<b>304</b> <b>(-5%)</b>	320	<b>336</b> <b>(+5%)</b>	
				<b>475</b> <b>(-5%)</b>	500	<b>535</b> <b>(+7%)</b>	
$I_{IND-OUT}$	Indicator LED Current Accuracy	$2.7\text{V} \leq V_{IN} \leq 5.5\text{V}$ $V_{IND} = 2.0\text{V}$ (Indicator Mode)		<b>(-20.4%)</b>	2.5 mA	<b>(+33.6%)</b>	%
				<b>(-20.4%)</b>	5.0mA	<b>(+33.8%)</b>	
				<b>(-20.3%)</b>	7.5mA	<b>(+33.7%)</b>	
				<b>(-20.2%)</b>	10.0mA	<b>(+33.4%)</b>	
$V_{CSH}$	Current Source Headroom Voltage	$2.7\text{V} \leq V_{IN} \leq 5.5\text{V}$		300	<b>350</b>	mV	
$V_{OVP}$	Over-Voltage Protection Range	$2.7\text{V} \leq V_{IN} \leq 5.5\text{V}$	Trip Point (Rising)	<b>9.22</b>	9.5	<b>9.96</b>	V
			Hysteresis		0.4		
$V_{OUT}$	Output Voltage Range	$(V_{LED} \times N_{LED}) + V_{CSH}$	Upper Range		8.5		V
			Lower Range		2.8		
$I_{SD}$	Shutdown Current	$2.7\text{V} \leq V_{IN} \leq 5.5\text{V}$				<b>0.75</b>	$\mu\text{A}$
$I_{SB}$	Standby Current	$2.7\text{V} \leq V_{IN} \leq 5.5\text{V}$			1.1	<b>4.3</b>	$\mu\text{A}$
$I_Q$	Operating Quiescent Current	$2.7\text{V} \leq V_{IN} \leq 5.5\text{V}$ Part Switching			3.5		mA
$V_{REF}$	Reference Voltage for LED Detection	$V_{IN} = 3.6\text{V}$ (No Offset)			4.35		V
$V_{IND}$	Indicator Fault Voltages	IND OVP		<b>2.571</b>			V
		IND Short				<b>0.842</b>	
UVLO	Under-Voltage Lock Out	Falling $V_{IN}$		<b>2.35</b>	2.4	<b>2.43</b>	V
UVLO <sub>HYST</sub>	UVLO Hysteresis	Rising $V_{IN}$		<b>60</b>	70	<b>85</b>	mV
$I_{LIM}$	Peak Current Limit	$2.7\text{V} \leq V_{IN} \leq 5.5\text{V}$ (3)	Current Limit Register value = 00	<b>1.183</b>	1.250	<b>1.550</b>	A
			Current Limit Register value = 01	<b>1.417</b>	1.500	<b>1.781</b>	
			Current Limit Register value = 10	<b>1.512</b>	1.750	<b>2.025</b>	
			Current Limit Register value = 11	<b>1.805</b>	2.000	<b>2.267</b>	
<b>OSCILLATOR AND TIMING SPECIFICATIONS (NON-I<sup>2</sup>C INTERFACE TIMING)</b>							
$f_{SW}$	Switching Frequency	$2.7\text{V} \leq V_{IN} \leq 5.5\text{V}$		<b>1.91</b> <b>(-4.5%)</b>	2.0	<b>2.15</b> <b>(+7.5%)</b>	MHz
$t_{HW}$	Hardware Flash Timeout	Default Timer			850		msec
$t_{RU}$	Current Ramp-Up Time	$I_{LED} = 0\text{mA}$ to $I_{LED} = \text{Fullscale}$ , $V_{OUT} = 6.5\text{V}$ , $V_{LED} = 6.2\text{V}$		<b>0.6</b>		<b>1.0</b>	msec
$t_{RD}$	Current Ramp Down Time	$I_{LED} = \text{Fullscale}$ to $I_{LED} = 0\text{mA}$ $V_{OUT} = 6.5\text{V}$ , $V_{LED} = 6.2\text{V}$		<b>0.2</b>		<b>0.5</b>	msec
$t_{TORCH-DG}$	Torch Deglitching Time			<b>6.3</b>	9	<b>11.7</b>	msec

(1) Min and Max limits are guaranteed by design, test, or statistical analysis. Typical (Typ) numbers are not guaranteed, but do represent the most likely norm. Unless otherwise specified, conditions for Typical specifications are:  $V_{IN} = 3.6\text{V}$  and  $T_A = 25^\circ\text{C}$ .

(2) Switching disabled.

(3)  $T_A$  (min) =  $0^\circ\text{C}$  to account for self-heating. Current Limit specification uses  $V_{IN}$  (Max) =  $4.0\text{V}$  to account for the input voltage range where current limit could be reached based upon the maximum application specifications for output voltage and diode current. Operation above  $4.0\text{V}$  and up to  $5.5\text{V}$  is allowed and should not reach current limit.

## Electrical Characteristics (continued)

Limits in standard typeface are for  $T_A = +25^\circ\text{C}$ . Limits in **boldface** type apply over the full operating ambient temperature range ( $-30^\circ\text{C} \leq T_A \leq +85^\circ\text{C}$ ). Unless otherwise specified:  $V_{IN} = 3.6\text{V}$ .<sup>(1) (2)</sup>

Symbol	Parameter	Conditions	Min	Typ	Max	Units
<b>CURRENT AND VOLTAGE SPECIFICATIONS</b>						
<b>CONTROL INTERFACE VOLTAGE SPECIFICATIONS</b>						
$V_{I2C/EN}$	I <sup>2</sup> C/EN Pin Voltage Threshold	$2.7\text{V} \leq V_{IN} \leq 5.5\text{V}$	Simple Mode		<b>0.54</b>	V
			I <sup>2</sup> C Mode	<b>1.26</b>		
$V_{IL}$	Low-Level Threshold Voltage (SCL/EN1 and SDA/EN2)	$2.7\text{V} \leq V_{IN} \leq 5.5\text{V}$			<b>0.54</b>	V
$V_{IH}$	High-Level Threshold Voltage (SCL/EN1 and SDA/EN2)	$2.7\text{V} \leq V_{IN} \leq 5.5\text{V}$		<b>1.26</b>		V
$V_{OL}$	Low-Level Output Threshold Limit (SDA/EN2)	$I_{LOAD} = 3\text{mA}$			<b>0.4</b>	V
<b>CONTROL INTERFACE TIMING SPECIFICATIONS</b>						
$T_{I2C-Start}$	I <sup>2</sup> C Logic Startup Time	I <sup>2</sup> C/EN going high		250	<b>500</b>	$\mu\text{sec}$
$f_{SCL}$	SCL Clock Frequency				<b>400</b>	kHz
$t_{I2C}$	I <sup>2</sup> C Hang-Up Tie			35		msec
$t_{LOW}$	Low Period of SCL Clock		<b>1.3</b>			$\mu\text{sec}$
$t_{HIGH}$	High Period of SCL Clock		<b>0.6</b>			$\mu\text{sec}$
$t_{HD-STA}$	Hold Time (repeated) START Condition		<b>0.6</b>			$\mu\text{sec}$
$t_{SU-STA}$	Setup time for a repeated START condition		<b>0.6</b>			$\mu\text{sec}$
$t_{HD-DAT}$	Data Hold Time		<b>0</b>			$\mu\text{sec}$
$t_{SU-DAT}$	Data Setup Time		<b>100</b>			nsec
$t_R$	Rise Time for SCL and SDA				<b>300</b>	nsec
$t_F$	Fall Time for SCL and SDA				<b>300</b>	nsec
$t_{SU-STO}$	Setup Time for Stop Condition		<b>0.6</b>			$\mu\text{sec}$
$t_{BUF}$	Bus Free Time between Stop and Start Condition		<b>1.3</b>			$\mu\text{sec}$
$t_{VD-DAT}$	Data Valid Time				<b>0.9</b>	$\mu\text{sec}$
$t_{VD-ACK}$	Data Valid Acknowledge Time				<b>0.9</b>	$\mu\text{sec}$
$C_B$	Capacitive Load for Each Bus Line		<b>20+0.1xC B</b>		<b>400</b>	pF

### Typical Characteristics

Unless otherwise specified:  $T_A = 25^\circ\text{C}$ ;  $V_{IN} = 3.6\text{V}$ ;  $C_{IN1} = 10\ \mu\text{F}$ ,  $C_{IN2} = 0.1\ \mu\text{F}$ ,  $C_{OUT} = 11\ \mu\text{F}$ ;  $L = 2.2\ \mu\text{H}$ .

**Two Series LEDs  
Flash Current  
vs  
Brightness Code**

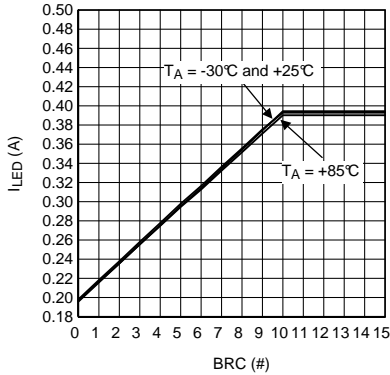

**Two Series LEDs @ 320mA  
LED Current  
vs  
Input Voltage**

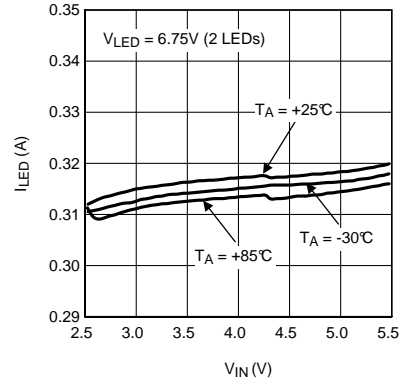

**Two Series LEDs @ 320mA  
Input Current  
vs  
Input Voltage**

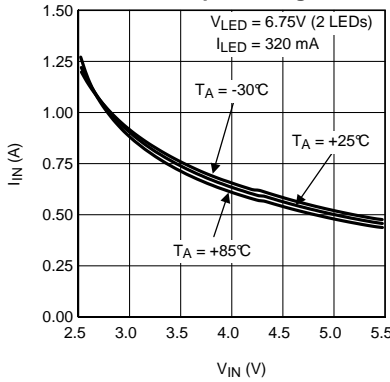

**Two Series LEDs @ 320mA  
LED Efficiency  
vs  
Input Voltage**

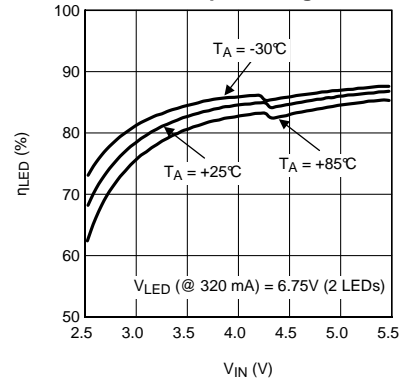

**Two Series LEDs @ 400mA  
LED Current  
vs  
Input Voltage**

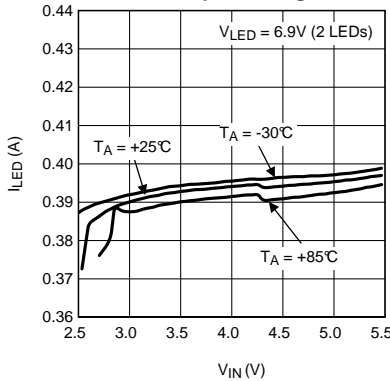

**Two Series LEDs @ 400mA  
Input Current  
vs  
Input Voltage**

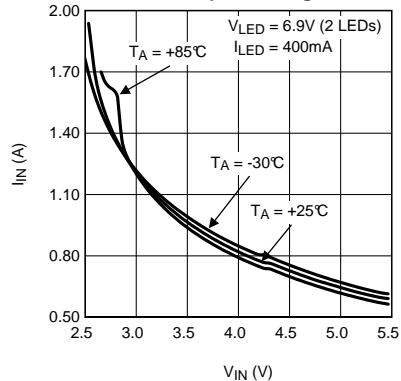

Typical Characteristics (continued)

Unless otherwise specified:  $T_A = 25^\circ\text{C}$ ;  $V_{IN} = 3.6\text{V}$ ;  $C_{IN1} = 10\ \mu\text{F}$ ,  $C_{IN2} = 0.1\ \mu\text{F}$ ,  $C_{OUT} = 11\ \mu\text{F}$ ;  $L = 2.2\ \mu\text{H}$ .

Two Series LEDs @ 400mA  
LED Efficiency  
vs  
Input Voltage

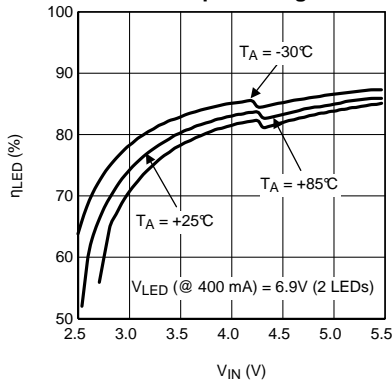

Torch Current  
vs  
Brightness Code  
2 LED

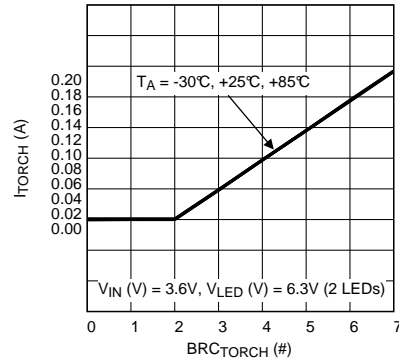

60mA Torch Current  
vs  
Input Voltage  
2 LED

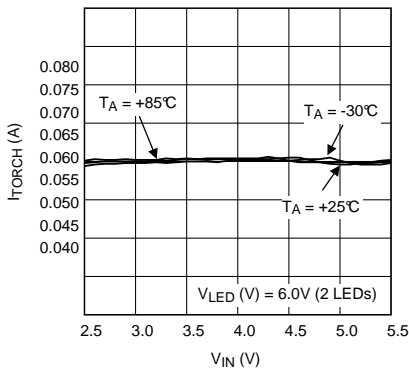

80mA Torch Current  
vs  
Input Voltage  
2 LED

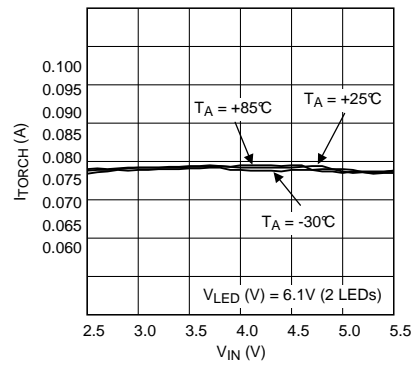

Two LEDs @ 60mA  
LED Efficiency  
vs  
Input Voltage

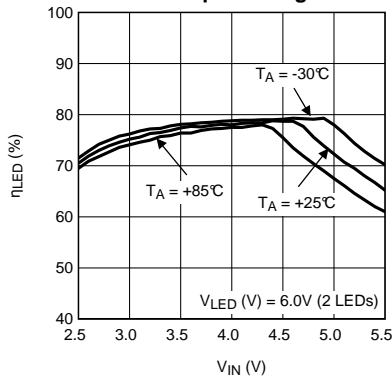

Two LEDs @ 80mA  
LED Efficiency  
vs  
Input Voltage

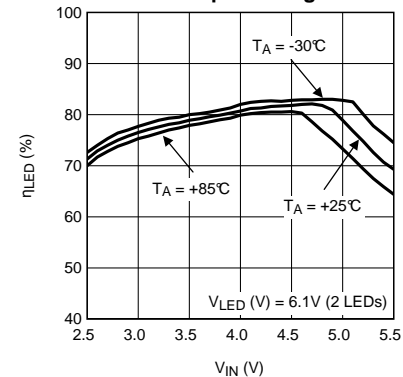

**Typical Characteristics (continued)**

Unless otherwise specified:  $T_A = 25^\circ\text{C}$ ;  $V_{IN} = 3.6\text{V}$ ;  $C_{IN1} = 10\ \mu\text{F}$ ,  $C_{IN2} = 0.1\ \mu\text{F}$ ,  $C_{OUT} = 11\ \mu\text{F}$ ;  $L = 2.2\ \mu\text{H}$ .

**Single LED  
Flash Current  
vs  
Brightness Code**

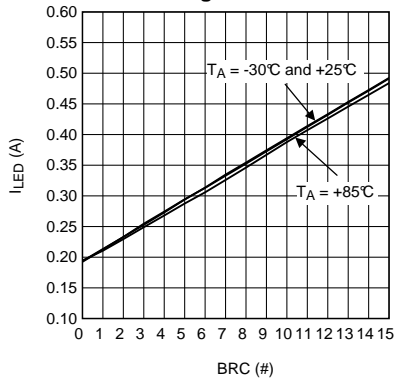

**One LED @ 500mA  
LED Current  
vs  
Input Voltage**

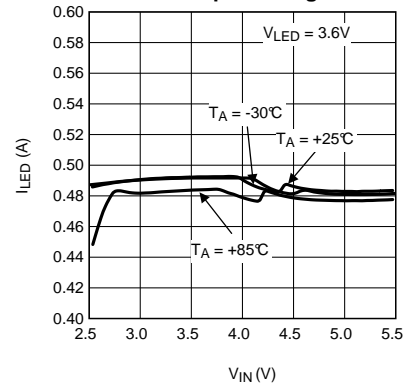

**One LED @ 500mA  
Input Current  
vs  
Input Voltage**

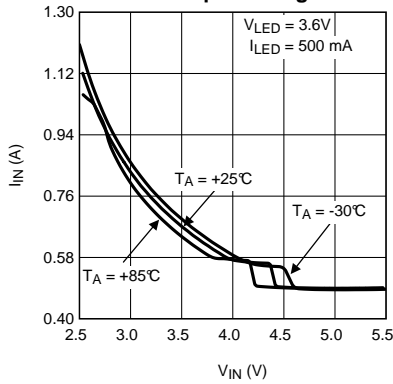

**One LED @ 500mA  
LED Efficiency  
vs  
Input Voltage**

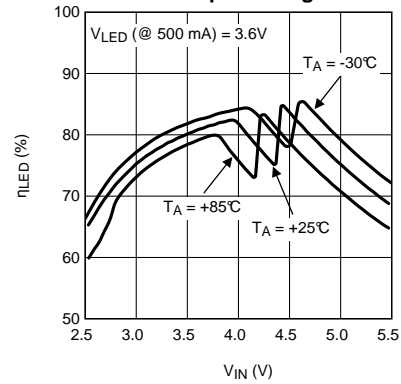

**Torch Current  
vs  
Brightness Code  
1 LED**

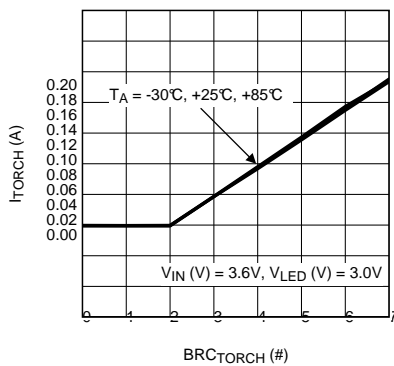

**60mA Torch Current  
vs  
Input Voltage  
1 LED**

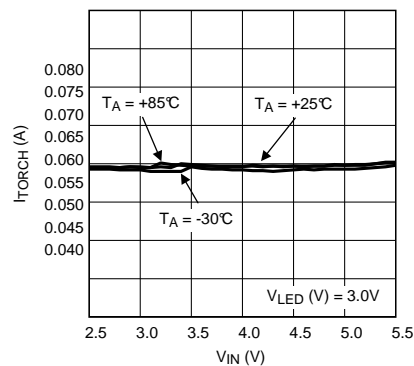

Typical Characteristics (continued)

Unless otherwise specified:  $T_A = 25^\circ\text{C}$ ;  $V_{IN} = 3.6\text{V}$ ;  $C_{IN1} = 10\ \mu\text{F}$ ,  $C_{IN2} = 0.1\ \mu\text{F}$ ,  $C_{OUT} = 11\ \mu\text{F}$ ;  $L = 2.2\ \mu\text{H}$ .

80mA Torch Current  
vs  
Input Voltage  
1 LED

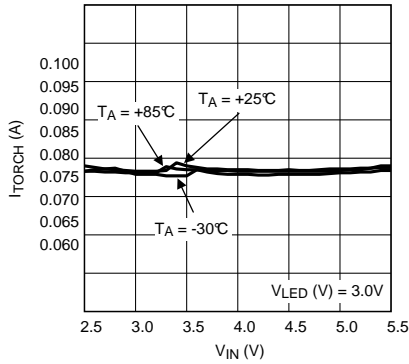

One LED @ 60mA  
LED Efficiency  
vs  
Input Voltage

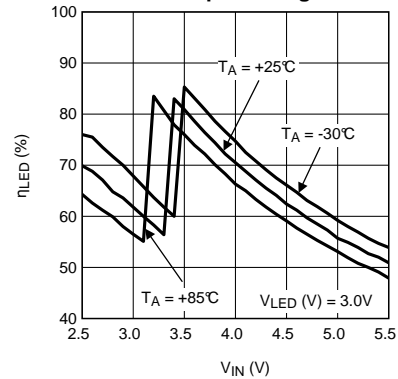

One LED @ 80mA  
LED Efficiency  
vs  
Input Voltage

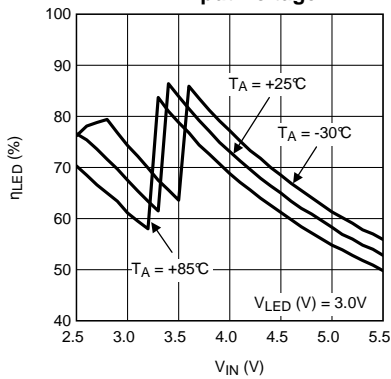

Indicator Current  
vs  
Input Voltage  
Brightness Codes

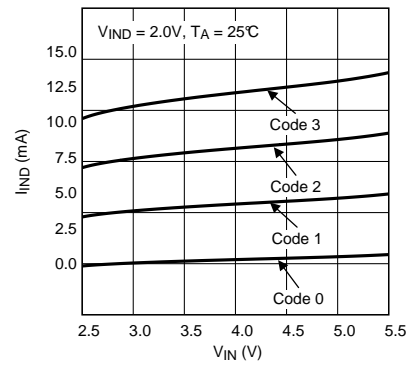

Indicator Current  
vs  
Input Voltage  
Tri-Temp

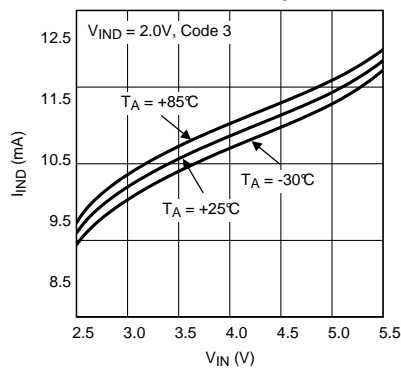

Indicator Current  
vs  
Input Voltage  
V\_LED

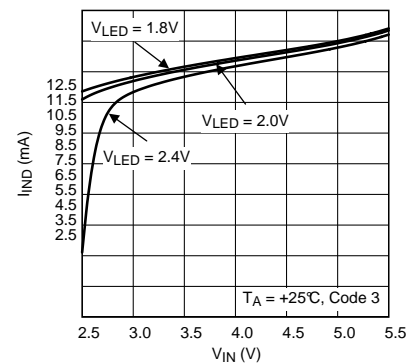

### Typical Characteristics (continued)

Unless otherwise specified:  $T_A = 25^\circ\text{C}$ ;  $V_{IN} = 3.6\text{V}$ ;  $C_{IN1} = 10\ \mu\text{F}$ ,  $C_{IN2} = 0.1\ \mu\text{F}$ ,  $C_{OUT} = 11\ \mu\text{F}$ ;  $L = 2.2\ \mu\text{H}$ .

**Inductor Current Limit vs Input Voltage**

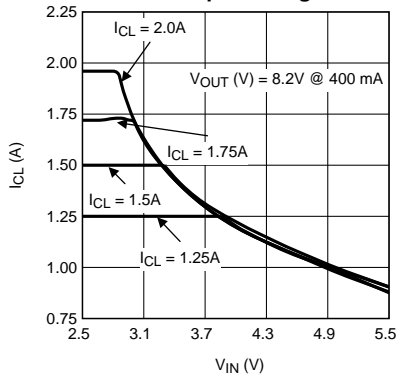

**LED Current vs Input Voltage In Current Limit**

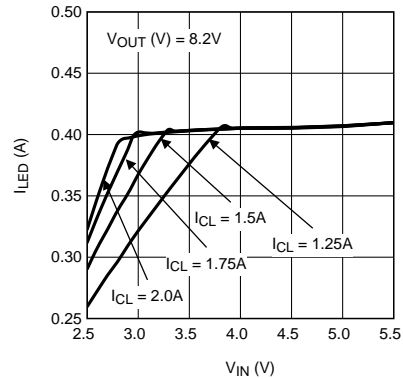

**Shutdown Current vs Input Voltage**

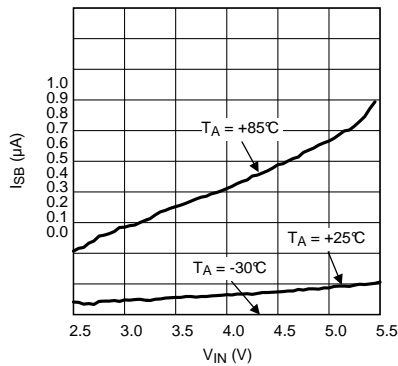

**Standby Current vs Input Voltage**

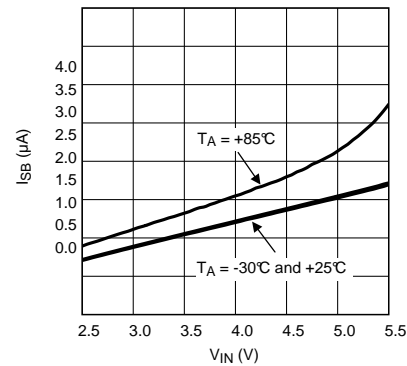

**Frequency vs Temperature**

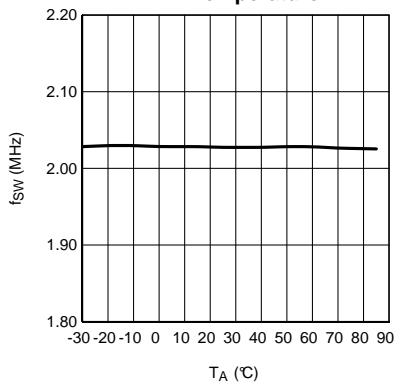

**Frequency vs Input Voltage**

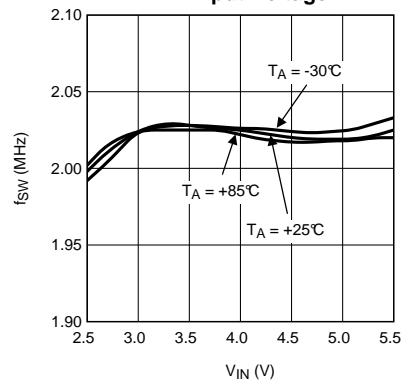

**Typical Characteristics (continued)**

Unless otherwise specified:  $T_A = 25^\circ\text{C}$ ;  $V_{IN} = 3.6\text{V}$ ;  $C_{IN1} = 10\ \mu\text{F}$ ,  $C_{IN2} = 0.1\ \mu\text{F}$ ,  $C_{OUT} = 11\ \mu\text{F}$ ;  $L = 2.2\ \mu\text{H}$ .

**Flash Timeout Time vs Flash Timeout Code**

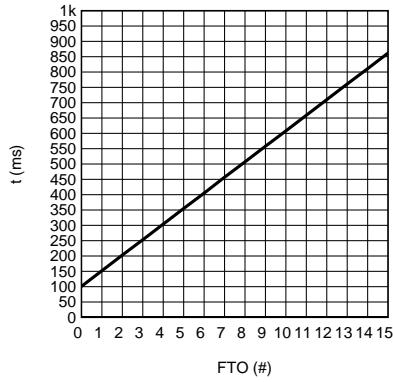

**Startup - 2 LEDs I<sup>2</sup>C Mode**

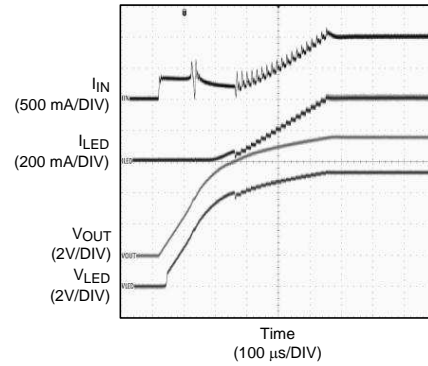

**Ramp-Down - 2 LEDs I<sup>2</sup>C Mode**

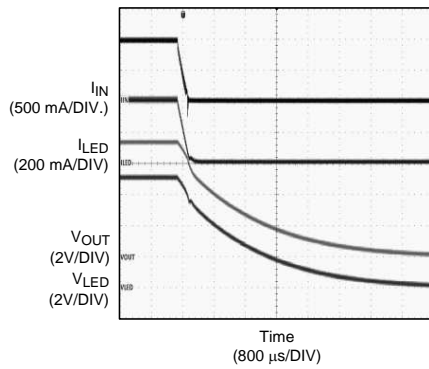

**Ramp-Down (Zoom) - 2 LEDs I<sup>2</sup>C Mode**

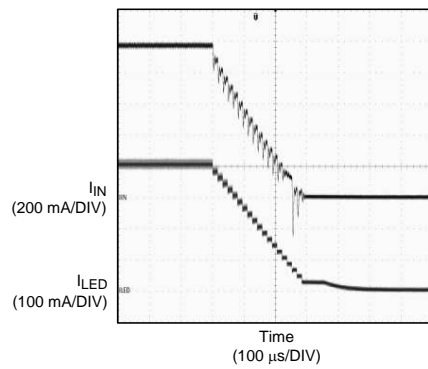

**Startup 2 LEDs Simple Mode**

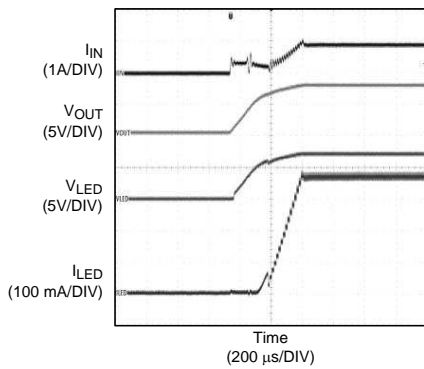

**Ramp-Down 2 LEDs Simple Mode**

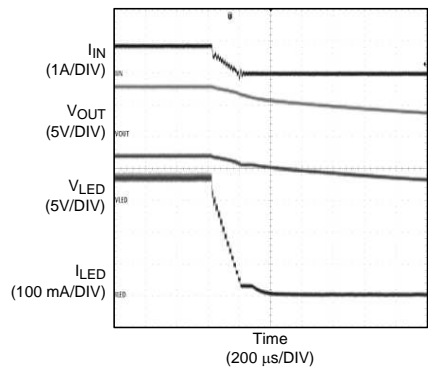

**Typical Characteristics (continued)**

Unless otherwise specified:  $T_A = 25^\circ\text{C}$ ;  $V_{IN} = 3.6\text{V}$ ;  $C_{IN1} = 10\ \mu\text{F}$ ,  $C_{IN2} = 0.1\ \mu\text{F}$ ,  $C_{OUT} = 11\ \mu\text{F}$ ;  $L = 2.2\ \mu\text{H}$ .

**Diode Detect - 2 LEDs Torch**

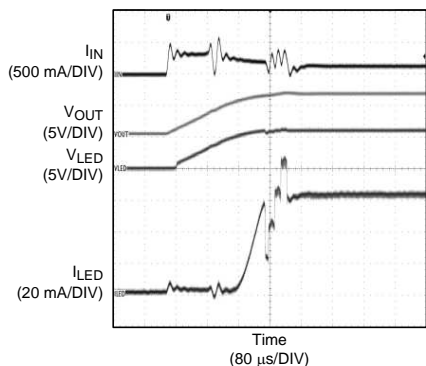

**Over-Voltage Protection Fault (OVP)**

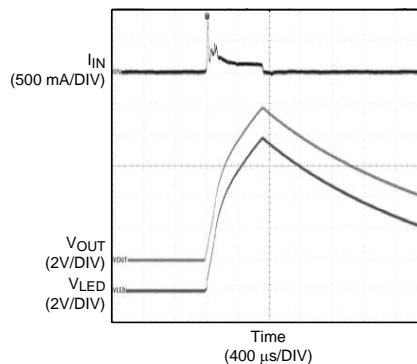

**VOUT Short to GND Fault**

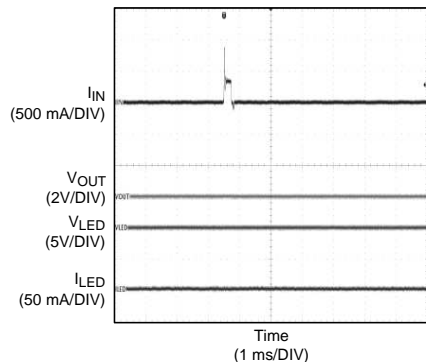

**VLED Short to GND Fault**

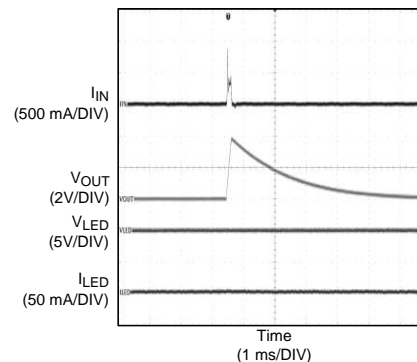

**Broken Inductor Fault**

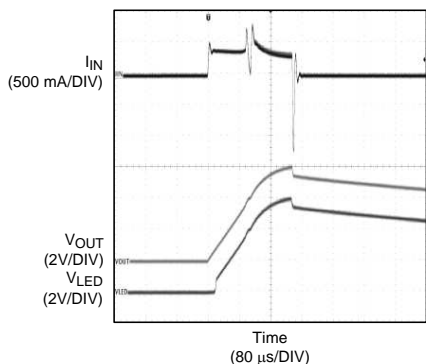

**Under-Voltage Lockout (UVLO)**

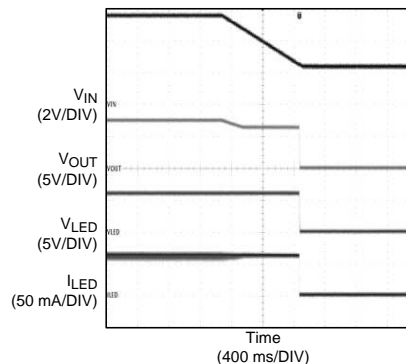

**Torch Deglitching Time**

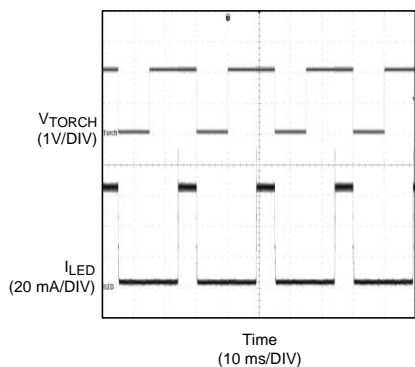

**Edge Sensitive Strobe**

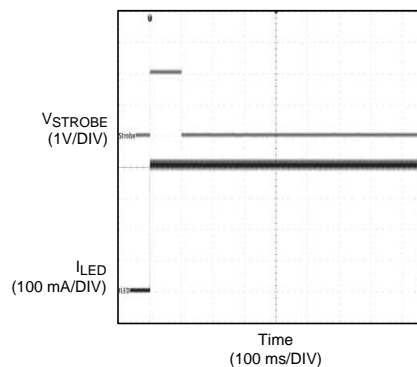

### Typical Characteristics (continued)

Unless otherwise specified:  $T_A = 25^\circ\text{C}$ ;  $V_{IN} = 3.6\text{V}$ ;  $C_{IN1} = 10\ \mu\text{F}$ ,  $C_{IN2} = 0.1\ \mu\text{F}$ ,  $C_{OUT} = 11\ \mu\text{F}$ ;  $L = 2.2\ \mu\text{H}$ .

**Level Sensitive Strobe with Timeout**

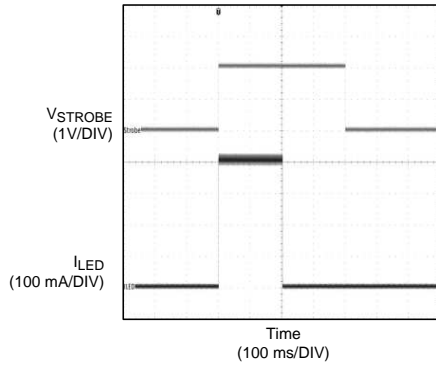

**Level Sensitive Strobe without Timeout**

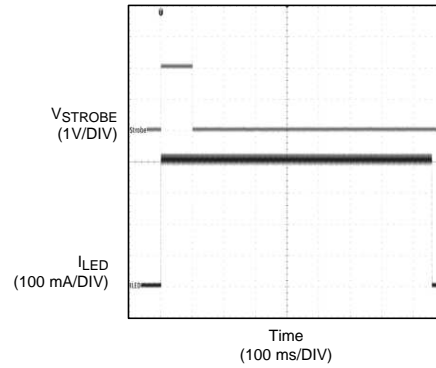

Block Diagram

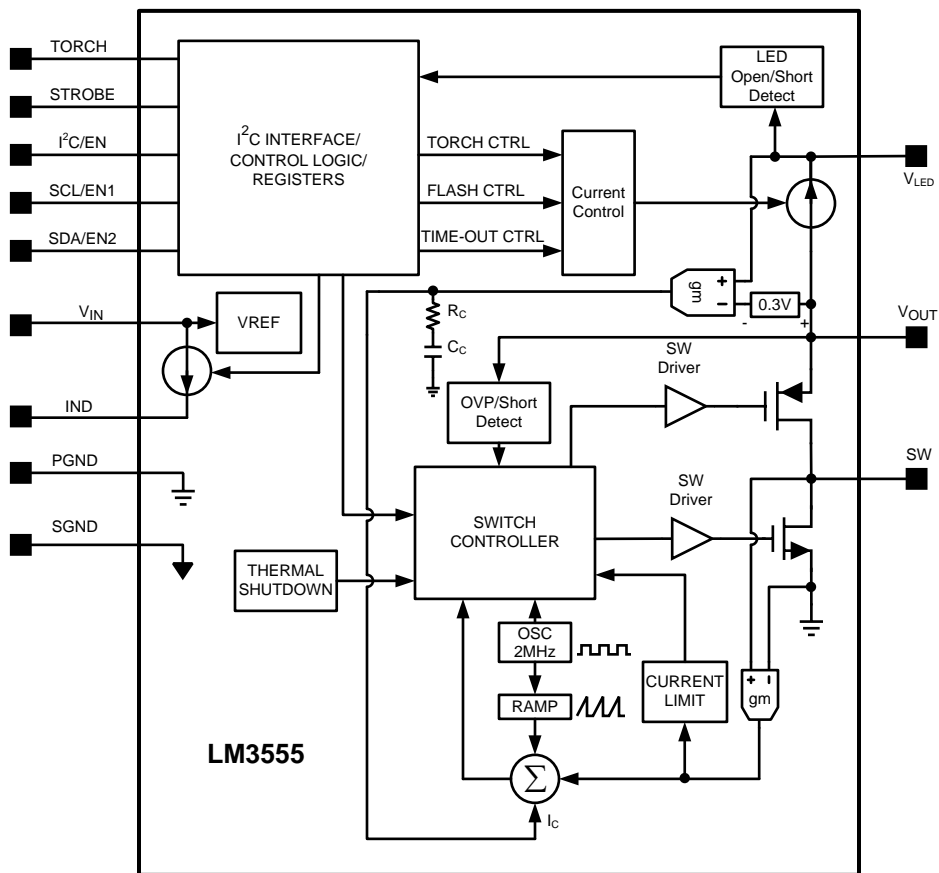

Application Circuit Component List

Component	Manufacturer	Value	Part-Number	Current/Voltage Rating (Resistance)
L	TOKO	2.2 $\mu$ H	FDS0312-2R2M	ISAT = 2.3A (0.2 $\Omega$ )
COU2	Murata	11 $\mu$ F	GRM219R61A116UE82B	10V
CIN1	Murata	10 $\mu$ F	GRM188R60J106UE82B	6.3V
CIN2	Murata	0.1 $\mu$ F	GRM155R61C104KA88B	16V

## Circuit Description

### OVERVIEW

The LM3555 is a high power white LED flash driver capable of delivering up to 500 mA of LED current into a single LED, or up to 400 mA into two series LEDs. The device incorporates a 2MHz constant frequency, synchronous, current mode PWM boost converter, and a single high side current source to regulate the LED current over the 2.5V to 5.5V input voltage range. Dual control interfaces (Simple ENABLE Control or I<sup>2</sup>C) and diode detection (single LED or two LEDs in series) make the LM3555 highly adaptable to a large variety of designs

### CIRCUIT COMPONENTS

#### *Synchronous Boost Converter*

The LM3555 operates in two modes: LED boost mode or LED pass mode. When the input voltage is above the LED voltage + current source headroom voltage the device turns the PFET on continuously (Pass mode). In Pass mode the difference between ( $V_{IN} - I_{LED} \times R_{ON\_P}$ ) and the voltage across the LEDs is dropped across the current source. When the output voltage ( $V_{OUT}$ ) is greater than the input voltage ( $V_{IN}$ ) minus approx. 200 mV, the PWM converter switches and maintains at least 300 mV across the current source (LED Boost mode). This minimum headroom voltage ensures that the current sinks remain in regulation.

Once the LM3555 transitions from Pass Mode to Boost Mode, the part will not return to Pass Mode until the part is disabled and re-enabled. At this point, the converter will re-evaluate the conditions and enter the appropriate mode

#### *High-Side Current Source*

The High-Side Current Source of the LM3555 is capable of driving one or two LEDs in series. Depending on the configuration, the LM3555 will automatically set default diode current levels and diode current limits. For a single LED, the flash current range is 200 mA to 500 mA in 20 mA steps with a default current equal to 500 mA. For two LEDs in series, the flash current range is 200 mA to 400 mA in 20 mA steps with a default current equal to 320 mA.

Additionally, the high-side current source is capable of supporting Assist/Torch current levels (continuous current) between 60 mA and 160 mA in 20 mA levels.

#### *I<sup>2</sup>C/EN Pin*

The I<sup>2</sup>C/EN pin on the LM3555 changes the control interface depending on its state. To use the LM3555 in the "Simple Control" mode, the I<sup>2</sup>C/EN pin must be tied low. To use the LM3555 in "I<sup>2</sup>C Control" mode, the I<sup>2</sup>C/EN pin must be tied high. Toggling this pin between Simple Control Mode and I<sup>2</sup>C Control Mode is not recommended.

#### *SDA/EN2 and SCL/EN1 Pins*

Depending on the state of the I<sup>2</sup>C/EN pin, the SDA/EN2 and SCL/EN1 pins will function in different ways. If the I<sup>2</sup>C/EN pin is equal to a '1', the SDA/EN2 pin will function as an I<sup>2</sup>C SDA (data) pin and the SCL/EN1 pin will function as an I<sup>2</sup>C SCL (Clock) pin. If the I<sup>2</sup>C/EN pin is equal to a '0', the SDA/EN2 pin will function as the simple control pin EN2 and the SCL/EN1 pin will function as the simple control pin EN1.

When using the Simple Control Mode, the Flash, Torch and Indicator Modes can be enabled. In Simple Control Mode, internal pulldown resistors on the SDA/EN2 and SCL/EN1 pins become active. In I<sup>2</sup>C Control Mode, these pulldowns become disabled.

### ***STROBE Pin***

The Strobe pin of the LM3555 provides an external method for initiating a flash event. In most cases, the Strobe pin is connected to an imaging module so that the image capture and flash event are synchronized. The Strobe pin is only functional when the LM3555 is placed into I<sup>2</sup>C Control Mode (I2C/EN = '1') and the Output On (OEN in 0x04) and Strobe Signal Mode (SEN in 0x04) bits are set ('1'). The Strobe pin can be configured to be an edge sensitive or level sensitive input by setting the Strobe Signal Usage bit (SSU in 0x04. '1' = Level, '0' = Edge). In Edge Sensitive mode, a rising edge transition ('0' to '1') will start the flash event and the internal flash timer will terminate the event. In Level Sensitive mode, a rising edge transition ('0' to '1') will start the flash event and a falling edge transition ('1' to '0') or the internal flash timer, whichever occurs first, will terminate the event. In I<sup>2</sup>C Mode, there is an internal pull-down resistor that becomes enabled on this pin.

In Simple Control mode, the Strobe pin functions as an output when a pullup resistor is connected, alerting the user to the number of flash LEDs present in the system. If the Strobe pin is outputting a '1', two LEDs are present, whereas a '0' indicates a single LED is present.

### ***TORCH Pin***

The Torch pin of the LM3555, depending on the state and configuration, allows the user to enable Torch/Assist Mode without having to write the command through the I<sup>2</sup>C bus or through toggling the EN1 and EN2 pins. In simple mode, the LM3555 will drive 60 mA of LED current if two series LEDs are present and 80mA is one LED is present. In I<sup>2</sup>C mode, the external torch mode bit (TEN in register 0x04) must be set to a '1' to allow an external torch (default value = '1'). In I<sup>2</sup>C mode, the torch mode current is equal to the Assist mode current level stored in register 0x03. The Torch pin has an internal pull-down resistor enabled in both Simple Mode and I<sup>2</sup>C Mode.

### ***Indicator LED Pin (IND)***

The Indicator LED current source pin (IND) is able to drive a single red indicator LED when the Anode is connected to the LM3555 and the Cathode is connected to Ground. In Simple Logic Mode, the default indicator current is 2.5mA, and in I<sup>2</sup>C Mode, the indicator LED current can be adjusted to 2.5 mA, 5.0 mA, 7.5 mA or 10 mA.

### ***Fault Protections***

The LM3555 has numerous internal fault protection mechanisms to help prevent damage to the LM3555 as well as the system in the event of a fault. In the event of a fault, the LM3555 will enter shutdown mode and will report a fault to the fault register (0x05). The faults that can be detected are as follows:

- Over-Voltage Protection (VOUT)
- Short-Circuit Protection (VOUT and VLED)
- Over-Temperature Protection
- Flash Timeout
- Indicator LED Protection (Open and Short)
- Broken Inductor Protection
- Under-Voltage Lock-Out (not reported)
- Inductor Current Limit (not reported)

### ***I<sup>2</sup>C-Compatible Interface***

#### **DATA VALIDITY**

The data on SDA line must be stable during the HIGH period of the clock signal (SCL). In other words, the state of the data line can only be changed when CLK is LOW.

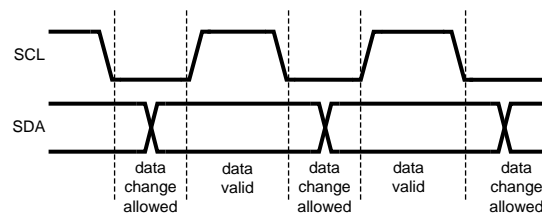
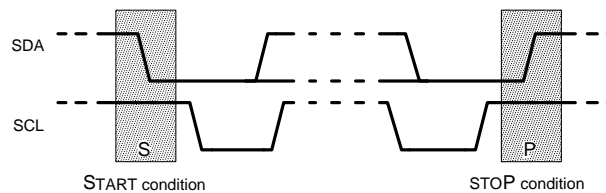

**Figure 1. Data Validity Diagram**

A pullup resistor between VIO and SDA must be greater than  $[(VIO - V_{OL}) / 3mA]$  to meet the  $V_{OL}$  requirement on SDA. Using a larger pullup resistor results in lower switching current with slower edges, while using a smaller pullup results in higher switching currents with faster edges.

### START AND STOP CONDITIONS

START and STOP conditions classify the beginning and the end of the I<sup>2</sup>C session. A START condition is defined as SDA signal transitioning from HIGH to LOW while SCL line is HIGH. A STOP condition is defined as the SDA transitioning from LOW to HIGH while SCL is HIGH. The I<sup>2</sup>C master always generates START and STOP conditions. The I<sup>2</sup>C bus is considered to be busy after a START condition and free after a STOP condition. During data transmission, the I<sup>2</sup>C master can generate repeated START conditions. First START and repeated START conditions are equivalent, function-wise. The data on SDA line must be stable during the HIGH period of the clock signal (SCL). In other words, the state of the data line can only be changed when CLK is LOW.

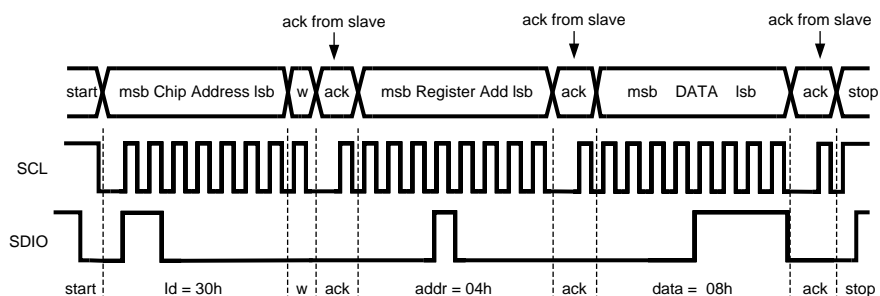

**Figure 2. Start and Stop Conditions**

### TRANSFERRING DATA

Every byte put on the SDA line must be eight bits long, with the most significant bit (MSB) being transferred first. Each byte of data has to be followed by an acknowledge bit. The acknowledge related clock pulse is generated by the master. The master releases the SDA line (HIGH) during the acknowledge clock pulse. The LM3555 pulls down the SDA line during the 9th clock pulse, signifying an acknowledge. The LM3555 generates an acknowledge after each byte has been received.

After the START condition, the I<sup>2</sup>C master sends a chip address. This address is seven bits long followed by an eighth bit which is a data direction bit (R/W). The LM3555 address is 30h. For the eighth bit, a "0" indicates a WRITE and a "1" indicates a READ. The second byte selects the register to which the data will be written. The third byte contains data to write to the selected register.



w = write (SDA = "0")  
 ack = acknowledge (SDA pulled down by the slave)  
 id = chip address, 30h for LM3555

Figure 3. Write Cycle

I<sup>2</sup>C-COMPATIBLE CHIP ADDRESS

The chip address for LM3555 is 0110000, or 30hex.



INTERNAL REGISTERS OF LM3555

Register	Internal Hex Address	Power On Value
Version Control Register	0x01	0000 1100
Indicator and Timer Register	0x02	0000 1111
Current Set Register	0x03	0110 1001
Control Register	0x04	1011 0100
Fault Register	0x05	0000 1000

REGISTER DEFINITIONS

**BOLD TABLE VALUES = Default Register Settings**

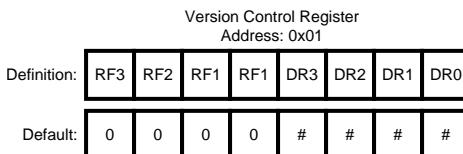

RF3–RF0: Unused  
 DR3–DR0: Design Revision = 1100

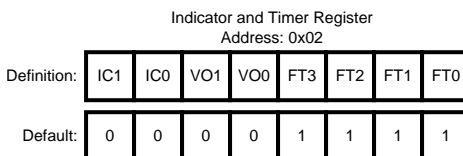

IC1–IC0: Indicator LED current control bits.  
 VO1-VO0: V<sub>REF</sub> Offset Adjustment bits. Used for diode detection.  
 FT3-FT0: Software Flash Timer Duration Control bits.

**INDICATOR CURRENTS**

IC1	IC0	Indicator LED Current
0	0	2.5 mA
0	1	5.0 mA
1	0	7.5 mA
1	1	10.0 mA

**V<sub>REF</sub> OFFSET VOLTAGES**

VO1	VO0	V <sub>REF</sub> Voltage (Offset from 4.35V)
0	0	4.35V (+0V)
0	1	4.65V (+0.3V)
1	0	4.05V (-0.3V)
1	1	4.95V (+0.6V)

**FLASH TIMEOUT DURATION**

FT3	FT2	FT1	FT0	Flash Timeout Duration
0	0	0	0	100 ms
0	0	0	1	150 ms
0	0	1	0	200 ms
0	0	1	1	250 ms
0	1	0	0	300 ms
0	1	0	1	350 ms
0	1	1	0	400 ms
0	1	1	1	450 ms
1	0	0	0	500 ms
1	0	0	1	550 ms
1	0	1	0	600 ms
1	0	1	1	650 ms
1	1	0	0	700 ms
1	1	0	1	750 ms
1	1	1	0	800 ms
1	1	1	1	850 ms

Current Set Register  
Address: 0x03

Definition:	FC3	FC2	FC1	FC0	DEN	AC2	AC1	AC0
Default:	0	1	1	0	1	0	0	1

FC3-FC0: Flash Current Control Bits.

DEN: Diode Detection Enable Bit. '1' = EN, '0' = Disabled. Default = '1' (Enabled)

AC2-AC0: Assist Light Current Control Bits.

**FLASH CURRENT LEVELS**

FC3	FC2	FC1	FC0	Flash Current Level
0	0	0	0	200 mA
0	0	0	1	220 mA
0	0	1	0	240 mA
0	0	1	1	260 mA

FC3	FC2	FC1	FC0	Flash Current Level
0	1	0	0	280 mA
0	1	0	1	300 mA
0	1	1	0	<b>320 mA (2 LEDs)</b>
0	1	1	1	340 mA
1	0	0	0	360 mA
1	0	0	1	380 mA
1	0	1	0	400 mA (2 LED Max)
1	0	1	1	420 mA
1	1	0	0	440 mA
1	1	0	1	460 mA
1	1	1	0	480 mA
1	1	1	1	<b>500 mA (1LED)</b>

### ASSIST LIGHT CURRENT LEVELS

AC2	AC1	AC0	Assist Current Level
0	0	0	60 mA
0	0	1	<b>60 mA (2 LEDs)</b>
0	1	0	60 mA
0	1	1	<b>80 mA (1 LED)</b>
1	0	0	100 mA
1	0	1	120 mA
1	1	0	140 mA
1	1	1	160 mA

 Control Register  
Address: 0x04

Definition:	IL1	IL0	SSU	TEN	OEN	SEN	OM1	OM0
Default:	1	0	1	1	0	1	0	0

IL1-IL0: Peak Inductor Current Limit Bits

SSU: Strobe Signal Usage. '0' = Edge Sensitive, '1' = Level Sensitive. '1' = Default

TEN: External Torch Mode Enable. '0' = Not allowed, '1' = Allowed. '1' = Default

OEN: Output Enable. '0' = Output Disabled, '1' = Output Enabled. '0' = Default

SEN: Strobe Signal Mode. '0' = Disabled, '1' = Enabled. '1' = Default

OM1-OM0: Output Mode Select Bits.

### PEAK INDUCTOR CURRENT LIMIT LEVELS

IL1	IL0	Peak Inductor Current Limit
0	0	1.25A
0	1	1.50A
1	0	<b>1.75A</b>
1	1	2.00A

### OUTPUT MODES

OM1	OM0	Output Mode
0	0	External Torch
0	1	Indicator
1	0	Assist Light
1	1	Flash

Fault and Info Register  
Address: 0x05

Definition:	OVP	SC	OTP	TO	DN	IF	IP	RFU
Default:	0	0	0	0	X	0	0	0

OVP: Over-Voltage Protection Fault. '1' = Fault, '0' = No Fault  
 SC: Short Circuit Fault. '1' = Fault, '0' = No Fault  
 OTP: Over-Temperature Protection Fault. '1' = Fault, '0' = No Fault  
 TO: Flash Timeout Fault. '1' = Fault, '0' = No Fault  
 DN: Number of LEDs. '1' = 2 LEDs, '0' = 1 LED. (This bit is R/W). '1' = Fault, '0' = No Fault  
 IF: Indicator LED Fault. '1' = Fault, '0' = No Fault  
 IP: Inductor Peak Current Limit Fault (Broken Inductor Fault). '1' = Fault, '0' = No Fault  
 RFU: Not Used .

**SIMPLE CONTROL STATE DIAGRAM**

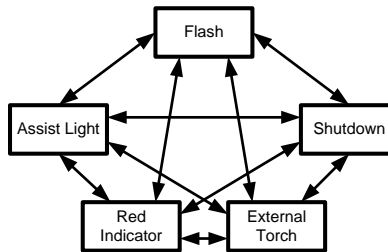

**SIMPLE MODE TRUTH TABLE**

I<sup>2</sup>C/EN = '0'

EN1	EN2	Torch	Mode
0	0	0	Shutdown
0	0	1	External Torch
0	1	X	Assist Light
1	0	X	Indicator
1	1	X	Flash

**I<sup>2</sup>C CONTROL STATE DIAGRAM**

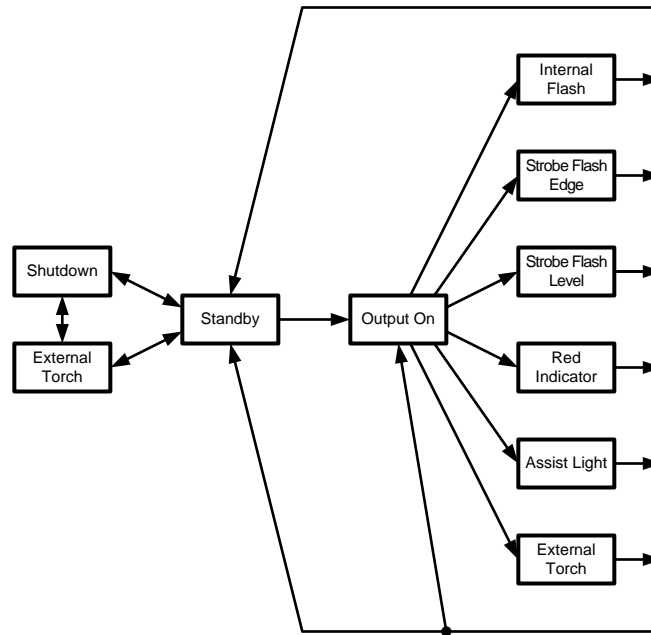

**I<sup>2</sup>C MODE TRUTH TABLE**

I<sup>2</sup>C/EN = '1', SCL and SDA = 'X'

OEN	OM1	OM0	TEN	SEN	TORCH	STROBE	Mode
0	0	0	0	X	X	X	Standby
0	0	0	1	X	0	X	Standby
0	0	0	1	X	1	X	Ext Torch
0	0	1	X	X	X	X	Standby
0	1	0	X	X	X	X	Standby
0	1	1	X	X	X	X	Standby
1	0	0	X	X	0	X	Standby
1	0	0	X	X	1	X	Ext Torch
1	0	1	X	X	X	X	Indicator
1	1	0	X	X	X	X	Assist
1	1	1	X	0	X	X	Internal Flash
1	1	1	X	1	X	0	Standby
1	1	1	X	1	X	1	Strobe Flash

**Application Information**

**INTERNAL DIODE DETECTION**

During the LM3555's startup sequence, an internal voltage comparator on the VLED pin monitors the forward voltage of the LED or LEDs. This measurement occurs when the ramp-up current reaches 80 mA. If at this time the diode voltage exceeds the user-selectable diode detect threshold (Register 0x02 bits VO1 and VO0), the LM3555 will assume two series LEDs are present and will limit the maximum flash current to 400 mA. The four adjustable levels are; '00' = 4.35V, '01' = 4.65V, '10' = 4.05V and '11' = 4.95V. This detection feature can be disabled by setting the Diode Detect Enable bit (DEN) in the Current Set Register (address 0x03) to a '0'. The DEN bit is set to a '1' (Enabled) by default.

In all cases during startup, the diode current will first ramp to 80 mA and then proceed to the target current. If the torch/assist current is set to 60 mA, the LM3555 will first reach 80 mA and then drop to 60 mA.

The number of LEDs present in the system is recorded in a read only Diode Number (DN) bit of the fault register (address 0x05). In Simple Mode, the number of LEDs present are output on the Strobe pin ('0' = 1 LED, '1' = 2 LEDs).

### SINGLE LED OPERATION

In single LED operation, the LED flash current is allowed to reach the maximum level of 500 mA. By default, the assist/torch current is set to 80 mA, and the flash current is set to 500 mA.

For input voltages that are higher than the LED forward voltage, the LM3555 will operate in a pass-mode. As  $V_{IN}$  drops, the LM3555 will first transition from pass-mode to the minimum duty-cycle boost mode. In this mode, the output voltage ( $V_{OUT}$ ) will increase to a level higher than needed to maintain current regulation through the current source. If  $V_{IN}$  continues to decrease, the LM3555 will transition again, this time from minimum duty-cycle boost mode to standard boost mode. Standard boost mode adjusts the converters duty-cycle to maintain 300 mV across the LM3555's current source.

Once the LM3555 transitions from pass mode to either boost mode, the part will stay in one of the boost modes until the part is disabled or timed-out and then restarted.

### DUAL LED OPERATION

In dual LED operation, the LED flash current is allowed to reach a maximum level of 400 mA. By default, the assist/torch current is set to 60 mA, and the flash current is set to 320 mA.

During Dual LED operation, the output voltage will always be greater than the input voltage (assuming standard white flash LEDs are used), forcing the LM3555 to be in boost mode over the entire input voltage range.

### TORCH or ASSIST (CONTINUOUS CURRENT) OPERATION

There are two different continuous current modes on the LM3555: Torch and Assist.

Torch mode is enabled through the use of the dedicated Torch pin using both Simple and I<sup>2</sup>C modes ('1' = Torch, '0' = Standby (I<sup>2</sup>C Mode) or Shutdown (Simple Mode)). In I<sup>2</sup>C control mode, the Torch pin functionality can be enabled and disabled through by setting the value of the TEN bit in the Control Register (Address 0x04). TEN = '1' allows an external Torch while TEN = '0' does not.

Assist mode is enabled in Simple Control mode by driving EN1 low ('0') and by driving EN2 high ('1'). In I<sup>2</sup>C control mode, Assist mode is enabled by setting the Output Mode bits (OM1 and OM0) to '10' and setting the Output Enable bit (OEN) to a '1' in the Control Register (0x04). Assist mode will remain active in I<sup>2</sup>C mode until the OEM bit is set to '0' or until a flash event occurs.

The LM3555 can drive one or two LEDs at continuous current levels ranging from 60 mA to 160 mA in 20 mA steps. In Simple Control mode, the torch and assist current levels are equal to 60 mA for two LEDs or 80 mA for a single LED. In I<sup>2</sup>C mode, the current is set in the Current Set Register (Address 0x30, AC2-AC0 bits).

### FLASH (PULSED CURRENT) OPERATION

A flash event using the LM3555 can be initiated through the dedicated control interface in both Simple and I<sup>2</sup>C modes, and through the use of the Strobe pin in I<sup>2</sup>C mode.

By driving both EN1 and EN2 high ('1') in Simple Mode, the part will enter flash mode and remain there until the control pins are driven low '0', or a timeout event occurs. In Simple Mode, the flash current is equal to 500 mA when driving a single LED and 320 mA when two LEDs are present. The default timeout duration is 850 ms.

When placed into I<sup>2</sup>C Control mode, a flash event is initiated when the Output Mode bits (OM1 and OM0) are set to '11' and the Output Enable bit (OEN) is set to a '1' in the Control Register (0x04). In I<sup>2</sup>C mode, the flash event will remain active as long as the OEN bit is set to a '1', and will terminate upon a timeout event. The safety timer duration can be set in 50 ms intervals ranging from 100 ms to 850 ms by writing the desired value to the FT3-FT0 bits in the Indicator and Timer Register (Address 0x02).

The Strobe pin provides added system flexibility in that it allows an additional external device (Camera Module, GPU etc.) to trigger a flash event. To initiate a Strobe event in I<sup>2</sup>C Control mode, the Strobe Signal Mode (SEN) bit and the Output Enable (OEN) bits in the Control Register (Address 0x04) must first be set to 1's.

Following the setting of the SEN and OEN bits, the user must chose to have an edge-sensitive or level-sensitive strobe event. Writing a '1' to the Strobe Signal Usage (SSU) bit in the Control Register (Address 0x04), the LM3555 will be configured to be level sensitive, while writing a '0' configures the part to be edge sensitive. In both cases, the strobe flash event is started upon the Strobe pin being driven high.

In an edge-sensitive event, the flash duration will stay active until the flash duration timer lapses regardless of the state of the Strobe pin. If a level-sensitive strobe is used, the flash event will remain active as long as the Strobe pin is held high and as long as the flash duration time has not lapsed.

In I<sup>2</sup>C Control mode, the end of a flash event, whether initiated through the Control Register or Strobe pin, will force the OEN bit to a '0' and will place the LM3555 back into the Standby state.

## INDICATOR OPERATION

Indicator mode is enabled in Simple Control mode by driving EN1 high ('1') and by driving EN2 high ('0'). In I<sup>2</sup>C control mode, Indicator mode is enabled by setting the Output Mode bits (OM1 and OM0) to '01' and setting the Output Enable bit (OEN) to a '1' in the Control Register (0x04). Indicator mode will remain active in I<sup>2</sup>C mode until the OEM bit is set to '0' or until a torch or flash event occurs.

In Simple Control Mode, the indicator LED current is fixed to 2.5 mA, while in I<sup>2</sup>C Control mode, the indicator current is adjustable to 2.5 mA, 5 mA, 7.5 mA or 10 mA by changing the values of the IC1 and IC0 bits in the Indicator and Timer Register (Address 0x02).

## FAULT PROTECTIONS

The LM3555 has a number of fault protection mechanisms designed to not only protect the LM3555 itself, but also the rest of the system. Active faults protections include:

- Over-Voltage Protection (VOUT)
- Short-Circuit Protection (VOUT and VLED)
- Over-Temperature Protection
- Flash Timeout
- Indicator LED Protection (Open and Short)
- Broken Inductor Protection

In the event that any of these faults occur, the LM3555 will set a flag in the Fault Register (Address 0x05) and place the part into standby or shutdown. In Simple Control Mode, normal operation cannot resume until the fault has been fixed and until EN1 and EN2 are driven low '0'. In I<sup>2</sup>C Control Mode, normal operation cannot resume until the fault has be fixed and until an I<sup>2</sup>C read of the faults register (0x05) has completed. The act of reading the fault register clears the fault bits.

### **Output Over-Voltage Protection (OVP)**

An OVP fault is triggered when the output voltage of the LM3555 reaches a value greater than 9.5V (typ.). The OVP condition is cleared when the output voltage (V<sub>OUT</sub>) is able to operate below 9.5V. An output capacitor or an LED that have become an open circuit can cause an OVP event to occur. This fault is reported to the OVP fault bit in the Fault Register (bit7 in address 0x05).

### **Output and LED Short Circuit Protection (SCP)**

An SCP fault is triggered when the output voltage (VOUT) and/or the VLED pin does not reach 0.8V in 0.5 ms. The short circuit condition is cleared when the output (VOUT) is allowed to reach its steady state target and when the LED\_OUT voltage rises above 0.8V. A shorted output capacitor or a shorted LED could cause this fault to occur. This fault is reported to the SC fault bit in the Fault Register (bit6 in address 0x05).

### **Over-Temperature Protection (OTP)**

An OTP fault is triggered when the diode junction temperature of the LM3555 reaches an internal temperature of around 150°C. The OTP condition is cleared when the junction temperature falls below 140°C. A printed circuit board (PCB) with poor thermal dissipation properties and very high ambient temperatures (greater that 85°C) could cause this fault to occur. Please refer to Texas Instruments Application Note: AN-1112: Micro SMD Wafer Level Chip Scale Package for more information regarding proper PCB layout. This fault is reported to the OTP fault bit in the Fault Register (bit5 in address 0x05).

### **Flash Timeout (FTP)**

An FTP fault is triggered any time the flash pulse duration reaches the Flash Timeout duration. In I<sup>2</sup>C control mode, the FTP fault will be triggered whenever a flash is initiated through the Control Register (OEN and OM1/OM0 bits) or through an edge-sensitive strobe event. A FTP fault could occur in Simple Control Mode if the controller tied to EN1 and EN2 pins cannot toggle the pins low at the desired pulse rate. This same condition could occur with a level-sensitive Strobe event controlled by a camera module. This fault is reported to the TO fault bit in the Fault Register (bit4 in address 0x05). A FTP fault is the only reported "fault" that does not need to be cleared before any additional LED event can occur.

### **Indicator Fault (IF)**

An IF fault is triggered when the voltage on the IND pin is greater than 2.571V or less than 0.842V. This fault indicates that there is either an open or a short present on the IND pin. The short circuit condition is cleared when the indicator pin is allowed to operate between 0.842V and 2.571V. A shorted or open indicator LED could cause this fault to occur. This fault is reported to the IF fault bit in the Fault Register (bit2 in address 0x05).

### **Broken Inductor Fault (IP)**

An IP fault is triggered when the LM3555 detects the inductor's inductance has dropped below an acceptable value. This fault indicates that the inductor has been damaged. An inductor that has had its ferrite material damaged could cause this fault to occur. This fault is reported to the IP fault bit in the Fault Register (bit1 in address 0x05).

## **INDUCTOR CURRENT LIMIT**

To prevent damage to the LM3555's inductor and to limit the power drawn by the LM3555 during a flash event, an Inductor Current Limit circuit is present. The LM3555 monitors the current through the inductor during the charge phase of the boost cycle. In the event that the inductor current reaches the current limit, the NFET of the converter will terminate the charge phase for that cycle. The process will repeat itself until the flash event has ended or until the input voltage increases to the point where the peak current is no longer reached. Hitting the peak inductor current limit will not disable the part. It will however limit the output power delivery to the LEDs.

In Simple Control Mode, the peak inductor current limit is set to 1.75A. In I<sup>2</sup>C Control Mode, the inductor current limit can be set to 1.25A, 1.5A, 1.75A and 2A depending on the values of the IL1 and IL0 bits in the Control Register (Address 0x04). The peak inductor current limit value can be used to help size the inductor to the appropriate saturation current level. For more information on inductor sizing, please refer to the *INDUCTOR SELECTION* section of this datasheet.

## **UNDER-VOLTAGE LOCK-OUT (UVLO)**

The LM3555 has an Under-Voltage Lock-Out (UVLO) feature that disables the parts operation in the event that the input voltage falls below 2.4V (typ.). In Simple Control Mode, the input voltage must increase to at least 2.47V (typ.) and the EN1 and EN2 pins must be toggled low ('0') before normal operation can resume.

In I<sup>2</sup>C Control mode, the Output Enable bit in the Control Register (Address 0x04) will be set to a '0' in the event of a UVLO occurrence. The input voltage must rise to at least 2.47V before the LM3555 will become fully functional again.

A UVLO event does not disturb the state of the other registers of the LM3555

## **POWER-ON RESET (POR)**

A Power-On Reset (POR) circuit is present on the LM3555 for use in I<sup>2</sup>C control mode. The POR circuit ensures that the part starts in a known "OFF" state and that the registers used in the I<sup>2</sup>C Control interface are initialized to the proper startup values once the input voltage reaches a voltage greater than 1.8V (typ.). An input voltage lower than 1.8V will not only place the part into UVLO, but will also clear all of the LM3555 registers.

## INDUCTOR SELECTION

The LM3555 is designed to use a 2.2 µH inductor. When the device is boosting ( $V_{OUT} > V_{IN}$ ) the inductor is one of the biggest sources of efficiency loss in the circuit. Therefore, choosing an inductor with the lowest possible series resistance is important. Additionally, the saturation rating of the inductor should be greater than the maximum operating peak current of the LM3555. This prevents excess efficiency loss that can occur with inductors that operate in saturation and prevents over heating of the inductor and possible damage. For proper inductor operation and circuit performance ensure that the inductor saturation and the peak current limit setting of the LM3555 (1.25A, 1.5A, 1.75A or 2A) is greater than  $I_{PEAK}$ .  $I_{PEAK}$  can be calculated by:

$$I_{PEAK} = \frac{I_{LOAD}}{\eta} \times \frac{V_{OUT}}{V_{IN}} + \Delta I_L$$

where

$$\Delta I_L = \frac{V_{IN} \times (V_{OUT} - V_{IN})}{2 \times f_{SW} \times L \times V_{OUT}}$$

**Table 1. Recommended Inductors**

Manufacturer	Part#	L / I <sub>SAT</sub>
Toko	FDSE312-2R2M	2.2 µH / 2.3A
Coilcraft	LPS4012-222ML	2.2 µH / 2.3A
TDK	VLF4014ST-2R2M1R9	2.2 µH / 2.0A

## CAPACITOR SELECTION

The LM3555 requires 2 external capacitors for proper operation ( $C_{IN} = 10 \mu\text{F}$  recommended (4.7 µF min.) and  $C_{OUT} = 10 \mu\text{F}$ ). An additional 0.1 µF input capacitor placed right next to the VIN pin is recommended. Surface-mount multi-layer ceramic capacitors are recommended. These capacitors are small, inexpensive and have very low equivalent series resistance (ESR <20 mΩ typ.). Tantalum capacitors, OS-CON capacitors, and aluminum electrolytic capacitors are not recommended for use with the LM3555 due to their high ESR, as compared to ceramic capacitors.

For most applications, ceramic capacitors with X7R or X5R temperature characteristic are preferred for use with the LM3555. These capacitors have tight capacitance tolerance (as good as ±10%) and hold their value over temperature (X7R: ±15% over -55°C to 125°C; X5R: ±15% over -55°C to 85°C).

Capacitors with Y5V or Z5U temperature characteristic are generally not recommended for use with the LM3555. Capacitors with these temperature characteristics typically have wide capacitance tolerance (+80%, -20%) and vary significantly over temperature (Y5V: +22%, -82% over -30°C to +85°C range; Z5U: +22%, -56% over +10°C to +85°C range). Under some conditions, a nominal 1µF Y5V or Z5U capacitor could have a capacitance of only 0.1 µF. Such detrimental deviation is likely to cause Y5V and Z5U capacitors to fail to meet the minimum capacitance requirements of the LM3555.

**The recommended voltage rating for the input capacitor is 10V (min = 6.3V). The recommended output capacitor voltage rating is 16V (min = 10V). The recommended value takes into account the DC bias capacitance losses, while the minimum rating takes into account the OVP trip levels.**

## LAYOUT CONSIDERATIONS

The micro SMD is a chip-scale package with good thermal properties. For more detailed instructions on handling and mounting micro SMD packages, please refer to Texas Instruments Application Note AN-1112.

The high switching frequencies and large peak currents make the PCB layout a critical part of the design. The proceeding steps must be followed to ensure stable operation and proper current source regulation.

1. Connect the inductor as close as possible to the SW pin. This reduces the inductance and resistance of the switching node which minimizes ringing and excess voltage drops.
2. Connect the return terminals of the input capacitor and the output capacitor as close as possible to the two ground pins (PGND and SGND) and through low impedance traces.
3. Bypass  $V_{IN}$  with a 10 µF ceramic capacitor and an additional 0.1 µF ceramic capacitor. Connect the positive

terminal of this capacitor as close as possible to  $V_{IN}$ .

4. Connect  $C_{OUT}$  as close as possible to the  $V_{OUT}$  pin. This reduces the inductance and resistance of the output bypass node which minimizes ringing and voltage drops. This will improve efficiency and decrease the noise injected into the current sources.

**PACKAGING INFORMATION**

Orderable Device	Status (1)	Package Type	Package Drawing	Pins	Package Qty	Eco Plan (2)	Lead/Ball Finish	MSL Peak Temp (3)	Op Temp (°C)	Top-Side Markings (4)	Samples
LM3555TLE/NOPB	ACTIVE	DSBGA	YZR	12	250	Green (RoHS & no Sb/Br)	SNAGCU	Level-1-260C-UNLIM	-30 to 85	3555	<a href="#">Samples</a>
LM3555TLX/NOPB	ACTIVE	DSBGA	YZR	12	3000	Green (RoHS & no Sb/Br)	SNAGCU	Level-1-260C-UNLIM	-30 to 85	3555	<a href="#">Samples</a>

(1) The marketing status values are defined as follows:

**ACTIVE:** Product device recommended for new designs.

**LIFEBUY:** TI has announced that the device will be discontinued, and a lifetime-buy period is in effect.

**NRND:** Not recommended for new designs. Device is in production to support existing customers, but TI does not recommend using this part in a new design.

**PREVIEW:** Device has been announced but is not in production. Samples may or may not be available.

**OBSOLETE:** TI has discontinued the production of the device.

(2) Eco Plan - The planned eco-friendly classification: Pb-Free (RoHS), Pb-Free (RoHS Exempt), or Green (RoHS & no Sb/Br) - please check <http://www.ti.com/productcontent> for the latest availability information and additional product content details.

**TBD:** The Pb-Free/Green conversion plan has not been defined.

**Pb-Free (RoHS):** TI's terms "Lead-Free" or "Pb-Free" mean semiconductor products that are compatible with the current RoHS requirements for all 6 substances, including the requirement that lead not exceed 0.1% by weight in homogeneous materials. Where designed to be soldered at high temperatures, TI Pb-Free products are suitable for use in specified lead-free processes.

**Pb-Free (RoHS Exempt):** This component has a RoHS exemption for either 1) lead-based flip-chip solder bumps used between the die and package, or 2) lead-based die adhesive used between the die and leadframe. The component is otherwise considered Pb-Free (RoHS compatible) as defined above.

**Green (RoHS & no Sb/Br):** TI defines "Green" to mean Pb-Free (RoHS compatible), and free of Bromine (Br) and Antimony (Sb) based flame retardants (Br or Sb do not exceed 0.1% by weight in homogeneous material)

(3) MSL, Peak Temp. -- The Moisture Sensitivity Level rating according to the JEDEC industry standard classifications, and peak solder temperature.

(4) Multiple Top-Side Markings will be inside parentheses. Only one Top-Side Marking contained in parentheses and separated by a "~" will appear on a device. If a line is indented then it is a continuation of the previous line and the two combined represent the entire Top-Side Marking for that device.

**Important Information and Disclaimer:** The information provided on this page represents TI's knowledge and belief as of the date that it is provided. TI bases its knowledge and belief on information provided by third parties, and makes no representation or warranty as to the accuracy of such information. Efforts are underway to better integrate information from third parties. TI has taken and continues to take reasonable steps to provide representative and accurate information but may not have conducted destructive testing or chemical analysis on incoming materials and chemicals. TI and TI suppliers consider certain information to be proprietary, and thus CAS numbers and other limited information may not be available for release.

In no event shall TI's liability arising out of such information exceed the total purchase price of the TI part(s) at issue in this document sold by TI to Customer on an annual basis.

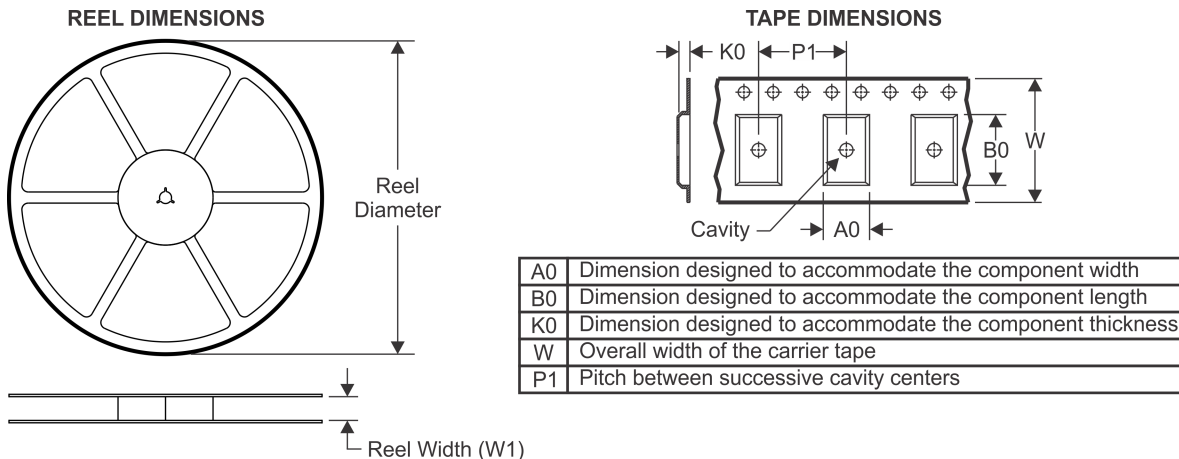
**TAPE AND REEL INFORMATION**

**QUADRANT ASSIGNMENTS FOR PIN 1 ORIENTATION IN TAPE**

\*All dimensions are nominal

Device	Package Type	Package Drawing	Pins	SPQ	Reel Diameter (mm)	Reel Width W1 (mm)	A0 (mm)	B0 (mm)	K0 (mm)	P1 (mm)	W (mm)	Pin1 Quadrant
LM3555TLE/NOPB	DSBGA	YZR	12	250	178.0	8.4	1.68	2.13	0.76	4.0	8.0	Q1
LM3555TLX/NOPB	DSBGA	YZR	12	3000	178.0	8.4	1.68	2.13	0.76	4.0	8.0	Q1

**TAPE AND REEL BOX DIMENSIONS**

\*All dimensions are nominal

Device	Package Type	Package Drawing	Pins	SPQ	Length (mm)	Width (mm)	Height (mm)
LM3555TLE/NOPB	DSBGA	YZR	12	250	210.0	185.0	35.0
LM3555TLX/NOPB	DSBGA	YZR	12	3000	210.0	185.0	35.0



## IMPORTANT NOTICE

Texas Instruments Incorporated and its subsidiaries (TI) reserve the right to make corrections, enhancements, improvements and other changes to its semiconductor products and services per JESD46, latest issue, and to discontinue any product or service per JESD48, latest issue. Buyers should obtain the latest relevant information before placing orders and should verify that such information is current and complete. All semiconductor products (also referred to herein as "components") are sold subject to TI's terms and conditions of sale supplied at the time of order acknowledgment.

TI warrants performance of its components to the specifications applicable at the time of sale, in accordance with the warranty in TI's terms and conditions of sale of semiconductor products. Testing and other quality control techniques are used to the extent TI deems necessary to support this warranty. Except where mandated by applicable law, testing of all parameters of each component is not necessarily performed.

TI assumes no liability for applications assistance or the design of Buyers' products. Buyers are responsible for their products and applications using TI components. To minimize the risks associated with Buyers' products and applications, Buyers should provide adequate design and operating safeguards.

TI does not warrant or represent that any license, either express or implied, is granted under any patent right, copyright, mask work right, or other intellectual property right relating to any combination, machine, or process in which TI components or services are used. Information published by TI regarding third-party products or services does not constitute a license to use such products or services or a warranty or endorsement thereof. Use of such information may require a license from a third party under the patents or other intellectual property of the third party, or a license from TI under the patents or other intellectual property of TI.

Reproduction of significant portions of TI information in TI data books or data sheets is permissible only if reproduction is without alteration and is accompanied by all associated warranties, conditions, limitations, and notices. TI is not responsible or liable for such altered documentation. Information of third parties may be subject to additional restrictions.

Resale of TI components or services with statements different from or beyond the parameters stated by TI for that component or service voids all express and any implied warranties for the associated TI component or service and is an unfair and deceptive business practice. TI is not responsible or liable for any such statements.

Buyer acknowledges and agrees that it is solely responsible for compliance with all legal, regulatory and safety-related requirements concerning its products, and any use of TI components in its applications, notwithstanding any applications-related information or support that may be provided by TI. Buyer represents and agrees that it has all the necessary expertise to create and implement safeguards which anticipate dangerous consequences of failures, monitor failures and their consequences, lessen the likelihood of failures that might cause harm and take appropriate remedial actions. Buyer will fully indemnify TI and its representatives against any damages arising out of the use of any TI components in safety-critical applications.

In some cases, TI components may be promoted specifically to facilitate safety-related applications. With such components, TI's goal is to help enable customers to design and create their own end-product solutions that meet applicable functional safety standards and requirements. Nonetheless, such components are subject to these terms.

No TI components are authorized for use in FDA Class III (or similar life-critical medical equipment) unless authorized officers of the parties have executed a special agreement specifically governing such use.

Only those TI components which TI has specifically designated as military grade or "enhanced plastic" are designed and intended for use in military/aerospace applications or environments. Buyer acknowledges and agrees that any military or aerospace use of TI components which have **not** been so designated is solely at the Buyer's risk, and that Buyer is solely responsible for compliance with all legal and regulatory requirements in connection with such use.

TI has specifically designated certain components as meeting ISO/TS16949 requirements, mainly for automotive use. In any case of use of non-designated products, TI will not be responsible for any failure to meet ISO/TS16949.

### Products

Audio	<a href="http://www.ti.com/audio">www.ti.com/audio</a>
Amplifiers	<a href="http://amplifier.ti.com">amplifier.ti.com</a>
Data Converters	<a href="http://dataconverter.ti.com">dataconverter.ti.com</a>
DLP® Products	<a href="http://www.dlp.com">www.dlp.com</a>
DSP	<a href="http://dsp.ti.com">dsp.ti.com</a>
Clocks and Timers	<a href="http://www.ti.com/clocks">www.ti.com/clocks</a>
Interface	<a href="http://interface.ti.com">interface.ti.com</a>
Logic	<a href="http://logic.ti.com">logic.ti.com</a>
Power Mgmt	<a href="http://power.ti.com">power.ti.com</a>
Microcontrollers	<a href="http://microcontroller.ti.com">microcontroller.ti.com</a>
RFID	<a href="http://www.ti-rfid.com">www.ti-rfid.com</a>
OMAP Applications Processors	<a href="http://www.ti.com/omap">www.ti.com/omap</a>
Wireless Connectivity	<a href="http://www.ti.com/wirelessconnectivity">www.ti.com/wirelessconnectivity</a>

### Applications

Automotive and Transportation	<a href="http://www.ti.com/automotive">www.ti.com/automotive</a>
Communications and Telecom	<a href="http://www.ti.com/communications">www.ti.com/communications</a>
Computers and Peripherals	<a href="http://www.ti.com/computers">www.ti.com/computers</a>
Consumer Electronics	<a href="http://www.ti.com/consumer-apps">www.ti.com/consumer-apps</a>
Energy and Lighting	<a href="http://www.ti.com/energy">www.ti.com/energy</a>
Industrial	<a href="http://www.ti.com/industrial">www.ti.com/industrial</a>
Medical	<a href="http://www.ti.com/medical">www.ti.com/medical</a>
Security	<a href="http://www.ti.com/security">www.ti.com/security</a>
Space, Avionics and Defense	<a href="http://www.ti.com/space-avionics-defense">www.ti.com/space-avionics-defense</a>
Video and Imaging	<a href="http://www.ti.com/video">www.ti.com/video</a>

### TI E2E Community

[e2e.ti.com](http://e2e.ti.com)