

## LM380 2.5W Audio Power Amplifier

Check for Samples: [LM380](#)

### FEATURES

- **Wide Supply Voltage Range: 10V-22V**
- **Low Quiescent Power Drain: 0.13W ( $V_S = 18V$ )**
- **Voltage Gain Fixed at 50**
- **High Peak Current Capability: 1.3A**
- **Input Referenced to GND**
- **High Input Impedance: 150k $\Omega$**
- **Low Distortion**
- **Quiescent Output Voltage is at One-Half of the Supply Voltage**
- **Standard Dual-In-Line Package**

### DESCRIPTION

The LM380 is a power audio amplifier for consumer applications. In order to hold system cost to a minimum, gain is internally fixed at 34 dB. A unique input stage allows ground referenced input signals. The output automatically self-centers to one-half the supply voltage.

The output is short circuit proof with internal thermal limiting. The package outline is standard dual-in-line. The LM380N uses a copper lead frame. The center three pins on either side comprise a heat sink. This makes the device easy to use in standard PC layouts.

Uses include simple phonograph amplifiers, intercoms, line drivers, teaching machine outputs, alarms, ultrasonic drivers, TV sound systems, AM-FM radio, small servo drivers, power converters, etc.

A selected part for more power on higher supply voltages is available as the LM384. For more information see [SNAA086](#).

### Connection Diagrams

(Dual-In-Line Packages, Top View)

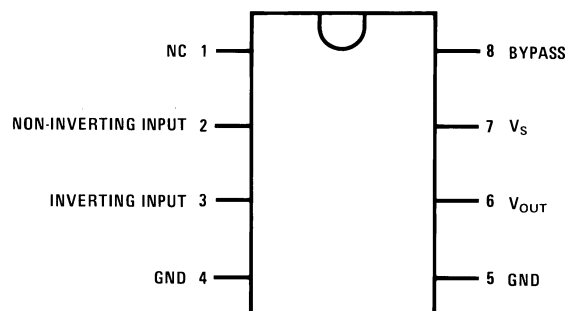
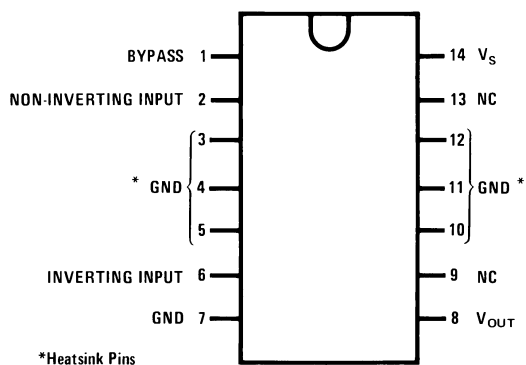

Block and Schematic Diagrams

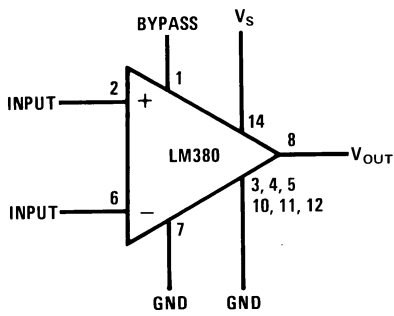

Figure 3. 14-Pin PDIP

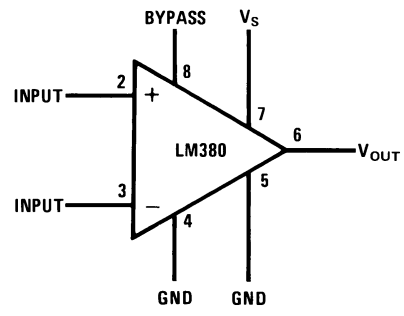

Figure 4. 8-Pin PDIP

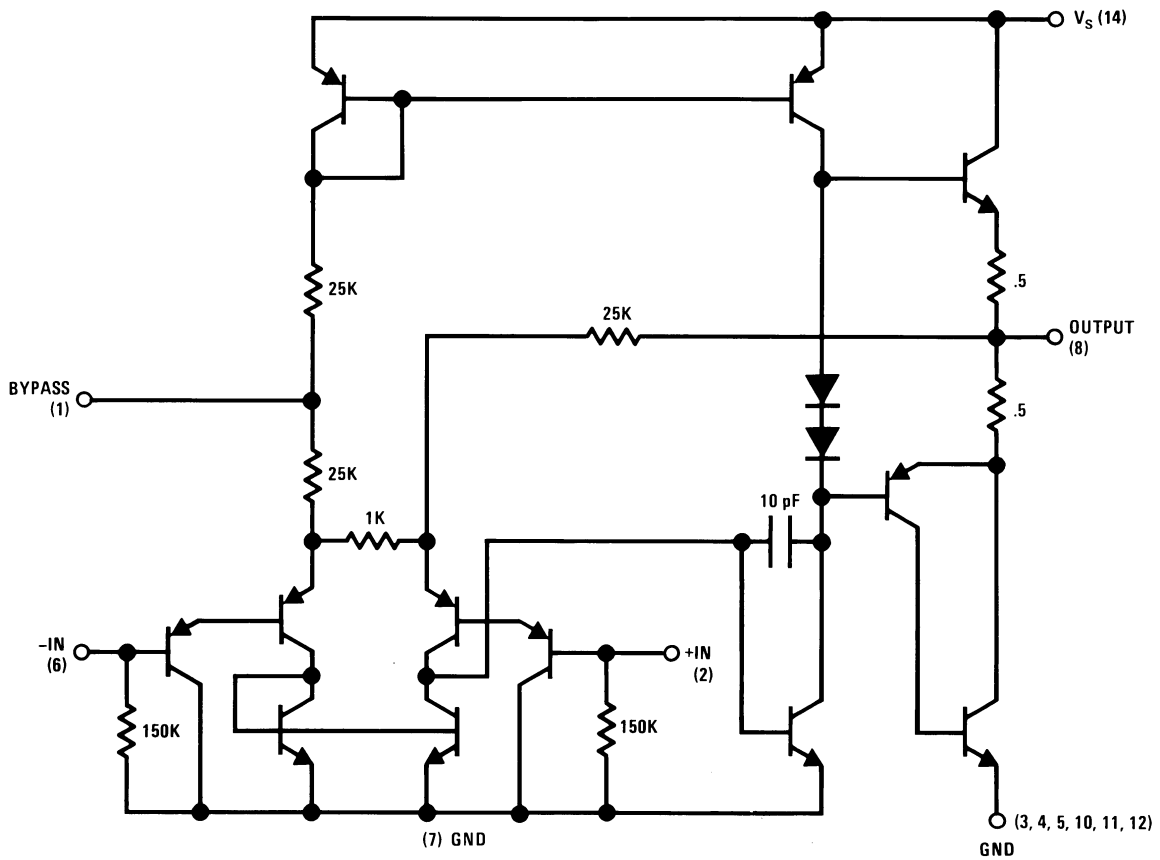

Figure 5.



These devices have limited built-in ESD protection. The leads should be shorted together or the device placed in conductive foam during storage or handling to prevent electrostatic damage to the MOS gates.

### Absolute Maximum Ratings<sup>(1)(2)</sup>

Supply Voltage		22V
Peak Current		1.3A
Package Dissipation	14-Pin PDIP <sup>(3)</sup>	8.3W
	8-Pin PDIP <sup>(3)</sup>	1.67W
Input Voltage		±0.5V
Storage Temperature		–65°C to +150°C
Operating Temperature		0°C to +70°C
Junction Temperature		+150°C
Lead Temperature (Soldering, 10 sec.)		+260°C
ESD rating to be determined		
Thermal Resistance	$\theta_{JC}$ (14-Pin PDIP)	30°C/W
	$\theta_{JC}$ (8-Pin PDIP)	37°C/W
	$\theta_{JA}$ (14-Pin PDIP)	79°C/W
	$\theta_{JA}$ (8-Pin PDIP)	107°C/W

- (1) "Absolute Maximum Ratings" indicate limits beyond which damage to the device may occur. Operating Ratings indicate conditions for which the device is functional, but do not ensure specific performance limits.
- (2) If Military/Aerospace specified devices are required, please contact the Texas Instruments Sales Office/Distributors for availability and specifications.
- (3) The package is to be derated at 15°C/W junction to heat sink pins for 14-pin pkg; 75°C/W for 8-pin.

### Electrical Characteristics<sup>(1)</sup>

Symbol	Parameter	Conditions	Min	Typ	Max	Units
$P_{OUT(RMS)}$	Output Power	$R_L = 8\Omega$ , THD = 3% <sup>(2)(3)</sup>	2.5			W
$A_V$	Gain		40	50	60	V/V
$V_{OUT}$	Output Voltage Swing	$R_L = 8\Omega$		14		$V_{p-p}$
$Z_{IN}$	Input Resistance			150k		$\Omega$
THD	Total Harmonic Distortion	See <sup>(3)(4)</sup>		0.2		%
PSRR	Power Supply Rejection Ratio	See <sup>(5)</sup>		38		dB
$V_S$	Supply Voltage		10		22	V
BW	Bandwidth	$P_{OUT} = 2W$ , $R_L = 8\Omega$		100k		Hz
$I_Q$	Quiescent Supply Current			7	25	mA
$V_{OUTQ}$	Quiescent Output Voltage		8	9.0	10	V
$I_{BIAS}$	Bias Current	Inputs Floating		100		nA
$I_{SC}$	Short Circuit Current			1.3		A

- (1)  $V_S = 18V$  and  $T_A = 25^\circ C$  unless otherwise specified.
- (2) With device Pins 3, 4, 5, 10, 11, 12 soldered into a 1/16" epoxy glass board with 2 ounce copper foil with a minimum surface of 6 square inches.
- (3)  $C_{BYPASS} = 0.47 \mu fd$  on Pin 1.
- (4) The maximum junction temperature of the LM380 is 150°C.
- (5) Rejection ratio referred to the output with  $C_{BYPASS} = 5 \mu F$ .

### Heat Sink Dimensions

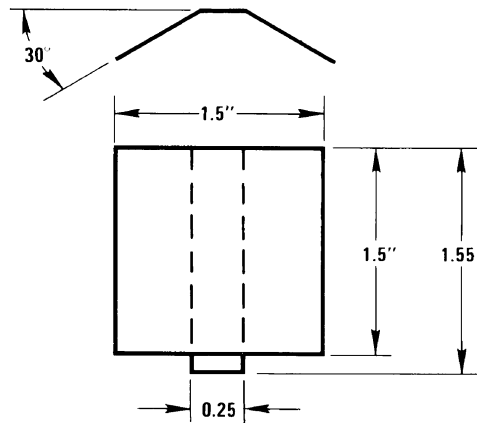

Staver Heat Sink #V-7  
Staver Company  
41 Saxon Ave.  
P.O. Drawer H  
Bayshore, NY 11706  
Tel: (516) 666-8000  
Copper Wings  
2 Required  
Soldered to  
Pins 3, 4, 5,  
10, 11, 12  
Thickness 0.04  
Inches

Typical Performance Characteristics

Maximum Device Dissipation vs Ambient Temperature

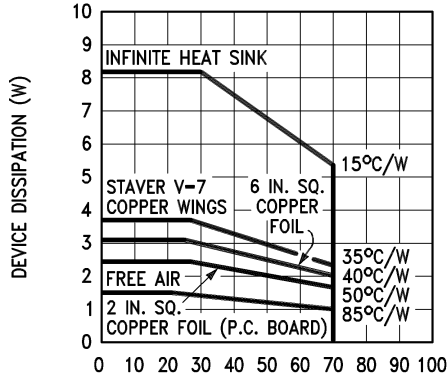

$T_A$  – AMBIENT TEMPERATURE (°C)  
 Note: 2 oz. copper foil, single-sided PC board.

Figure 6.

Device Dissipation vs Output Power—4Ω Load

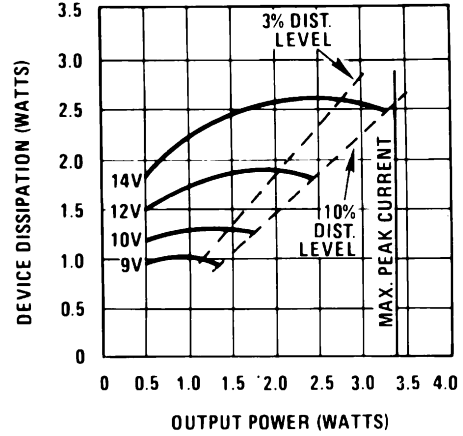

Figure 7.

Device Dissipation vs Output Power—8Ω Load

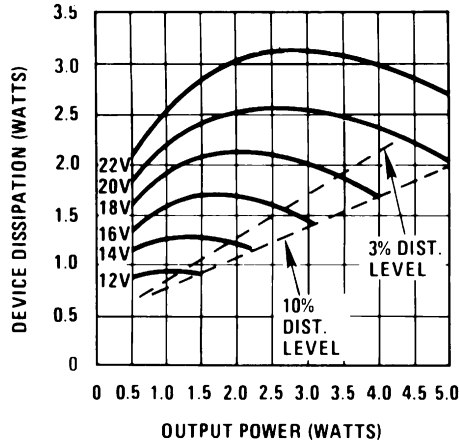

Figure 8.

Device Dissipation vs Output Power—16Ω Load

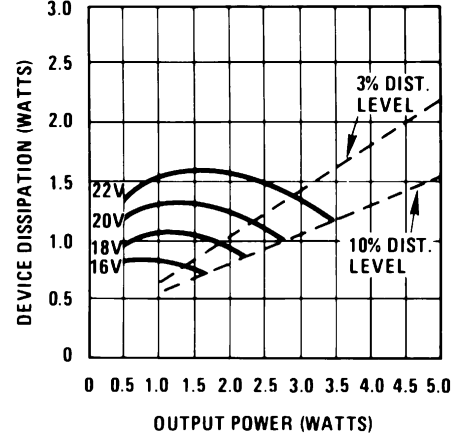

Figure 9.

Power Supply Current vs Supply Voltage

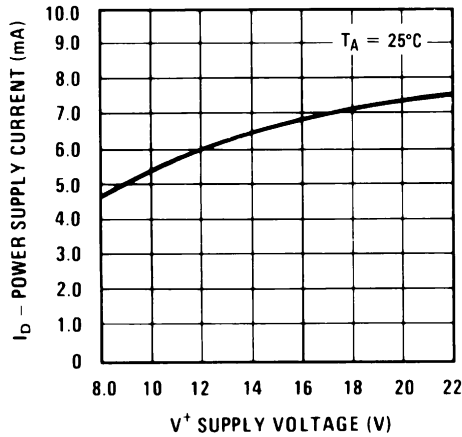

Figure 10.

Total Harmonic Distortion vs Frequency

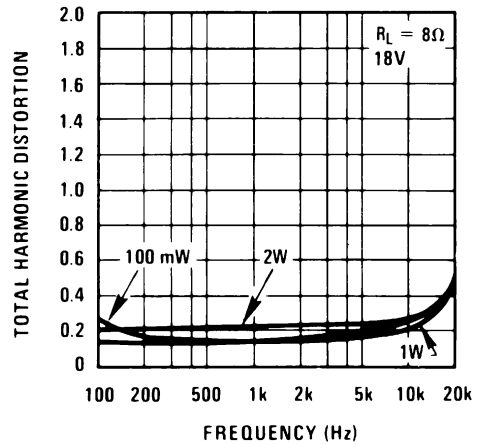

Figure 11.

Typical Performance Characteristics (continued)

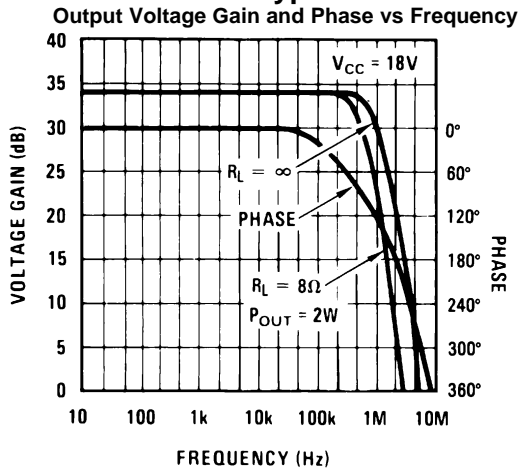

Figure 12.

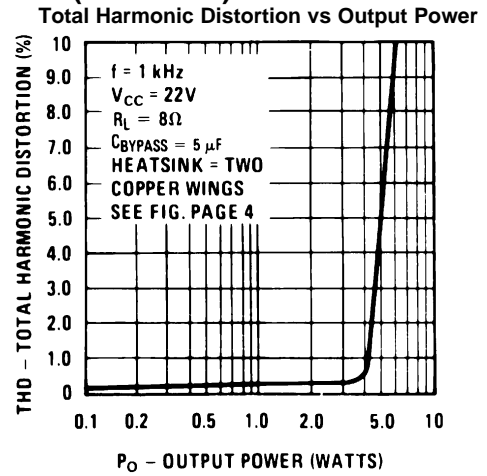

Figure 13.

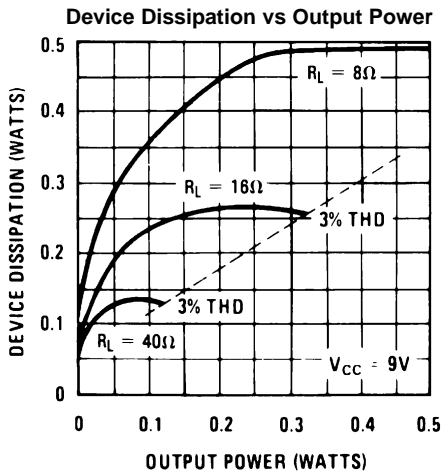

Figure 14.

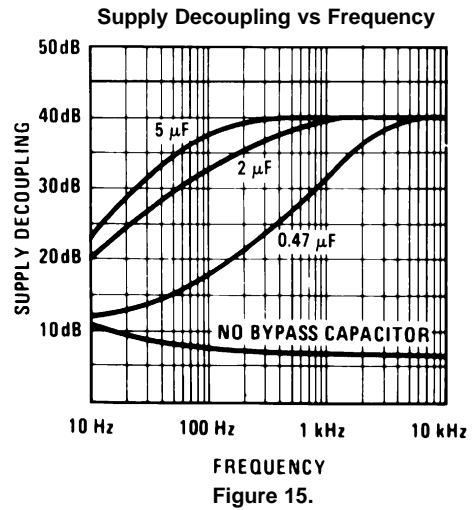

Figure 15.

Typical Applications

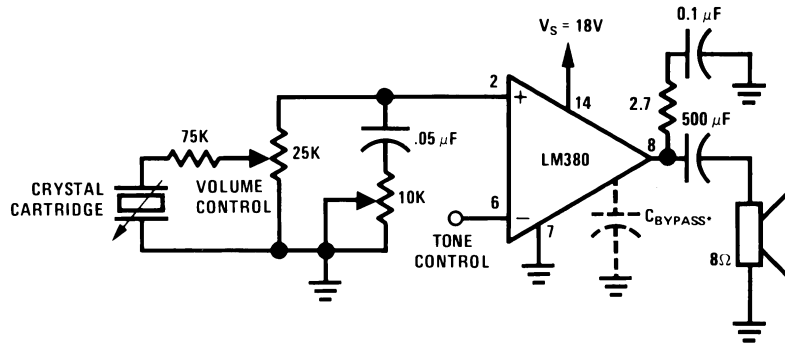

Figure 16. Phono Amplifier

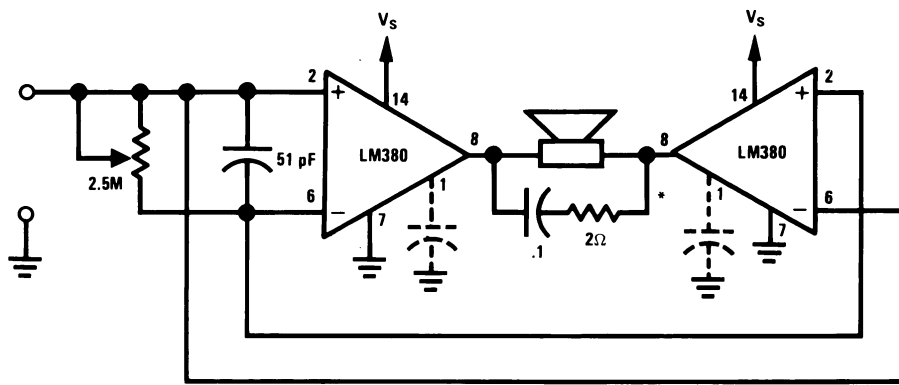
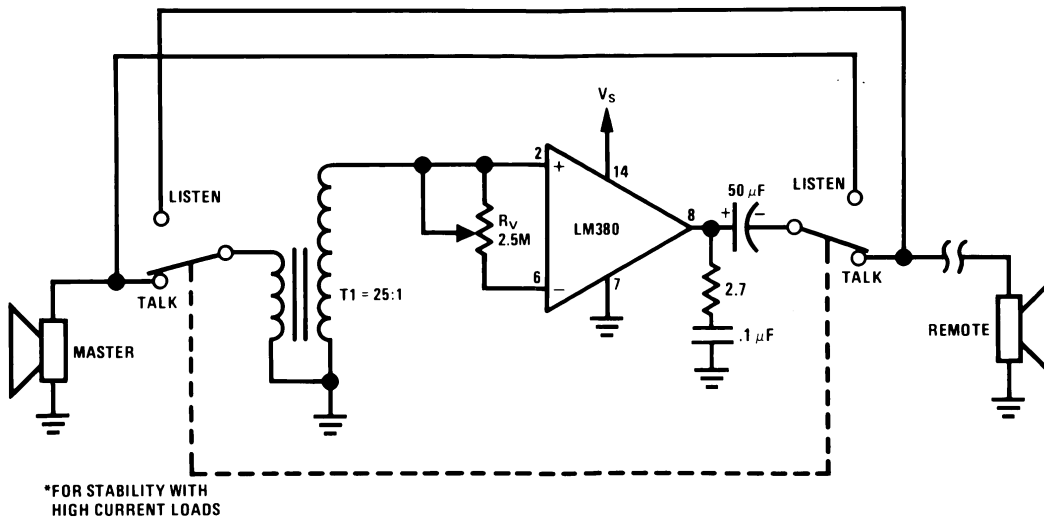

Figure 17. Bridge Amplifier



\*FOR STABILITY WITH HIGH CURRENT LOADS

Figure 18. Intercom

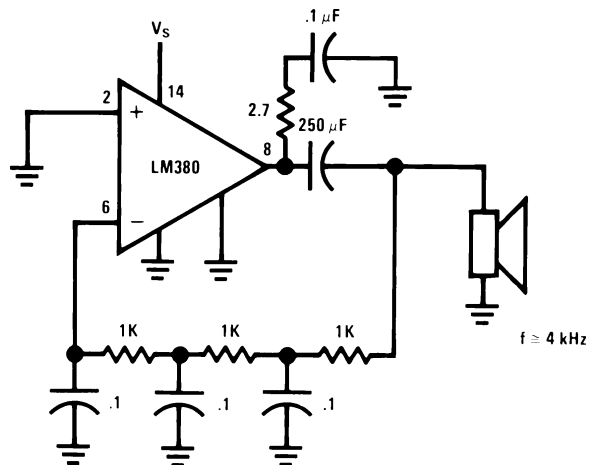

Figure 19. Phase Shift Oscillator

## REVISION HISTORY

Changes from Revision B (April 2013) to Revision C	Page
• Changed layout of National Data Sheet to TI format .....	8

---

## PACKAGING INFORMATION

Orderable Device	Status (1)	Package Type	Package Drawing	Pins	Package Qty	Eco Plan (2)	Lead/Ball Finish (6)	MSL Peak Temp (3)	Op Temp (°C)	Device Marking (4/5)	Samples
LM380N-8/NOPB	LIFEBUY	PDIP	P	8	40	Green (RoHS & no Sb/Br)	CU SN	Level-1-NA-UNLIM	0 to 70	LM 380N-8	
LM380N/NOPB	LIFEBUY	PDIP	NFF	14	25	Green (RoHS & no Sb/Br)	CU SN	Level-1-NA-UNLIM	0 to 70	LM380N	

(1) The marketing status values are defined as follows:

**ACTIVE:** Product device recommended for new designs.

**LIFEBUY:** TI has announced that the device will be discontinued, and a lifetime-buy period is in effect.

**NRND:** Not recommended for new designs. Device is in production to support existing customers, but TI does not recommend using this part in a new design.

**PREVIEW:** Device has been announced but is not in production. Samples may or may not be available.

**OBSELETE:** TI has discontinued the production of the device.

(2) Eco Plan - The planned eco-friendly classification: Pb-Free (RoHS), Pb-Free (RoHS Exempt), or Green (RoHS & no Sb/Br) - please check <http://www.ti.com/productcontent> for the latest availability information and additional product content details.

**TBD:** The Pb-Free/Green conversion plan has not been defined.

**Pb-Free (RoHS):** TI's terms "Lead-Free" or "Pb-Free" mean semiconductor products that are compatible with the current RoHS requirements for all 6 substances, including the requirement that lead not exceed 0.1% by weight in homogeneous materials. Where designed to be soldered at high temperatures, TI Pb-Free products are suitable for use in specified lead-free processes.

**Pb-Free (RoHS Exempt):** This component has a RoHS exemption for either 1) lead-based flip-chip solder bumps used between the die and package, or 2) lead-based die adhesive used between the die and leadframe. The component is otherwise considered Pb-Free (RoHS compatible) as defined above.

**Green (RoHS & no Sb/Br):** TI defines "Green" to mean Pb-Free (RoHS compatible), and free of Bromine (Br) and Antimony (Sb) based flame retardants (Br or Sb do not exceed 0.1% by weight in homogeneous material)

(3) MSL, Peak Temp. - The Moisture Sensitivity Level rating according to the JEDEC industry standard classifications, and peak solder temperature.

(4) There may be additional marking, which relates to the logo, the lot trace code information, or the environmental category on the device.

(5) Multiple Device Markings will be inside parentheses. Only one Device Marking contained in parentheses and separated by a "~" will appear on a device. If a line is indented then it is a continuation of the previous line and the two combined represent the entire Device Marking for that device.

(6) Lead/Ball Finish - Orderable Devices may have multiple material finish options. Finish options are separated by a vertical ruled line. Lead/Ball Finish values may wrap to two lines if the finish value exceeds the maximum column width.

**Important Information and Disclaimer:** The information provided on this page represents TI's knowledge and belief as of the date that it is provided. TI bases its knowledge and belief on information provided by third parties, and makes no representation or warranty as to the accuracy of such information. Efforts are underway to better integrate information from third parties. TI has taken and continues to take reasonable steps to provide representative and accurate information but may not have conducted destructive testing or chemical analysis on incoming materials and chemicals. TI and TI suppliers consider certain information to be proprietary, and thus CAS numbers and other limited information may not be available for release.

In no event shall TI's liability arising out of such information exceed the total purchase price of the TI part(s) at issue in this document sold by TI to Customer on an annual basis.

# MECHANICAL DATA

P (R-PDIP-T8)

PLASTIC DUAL-IN-LINE PACKAGE

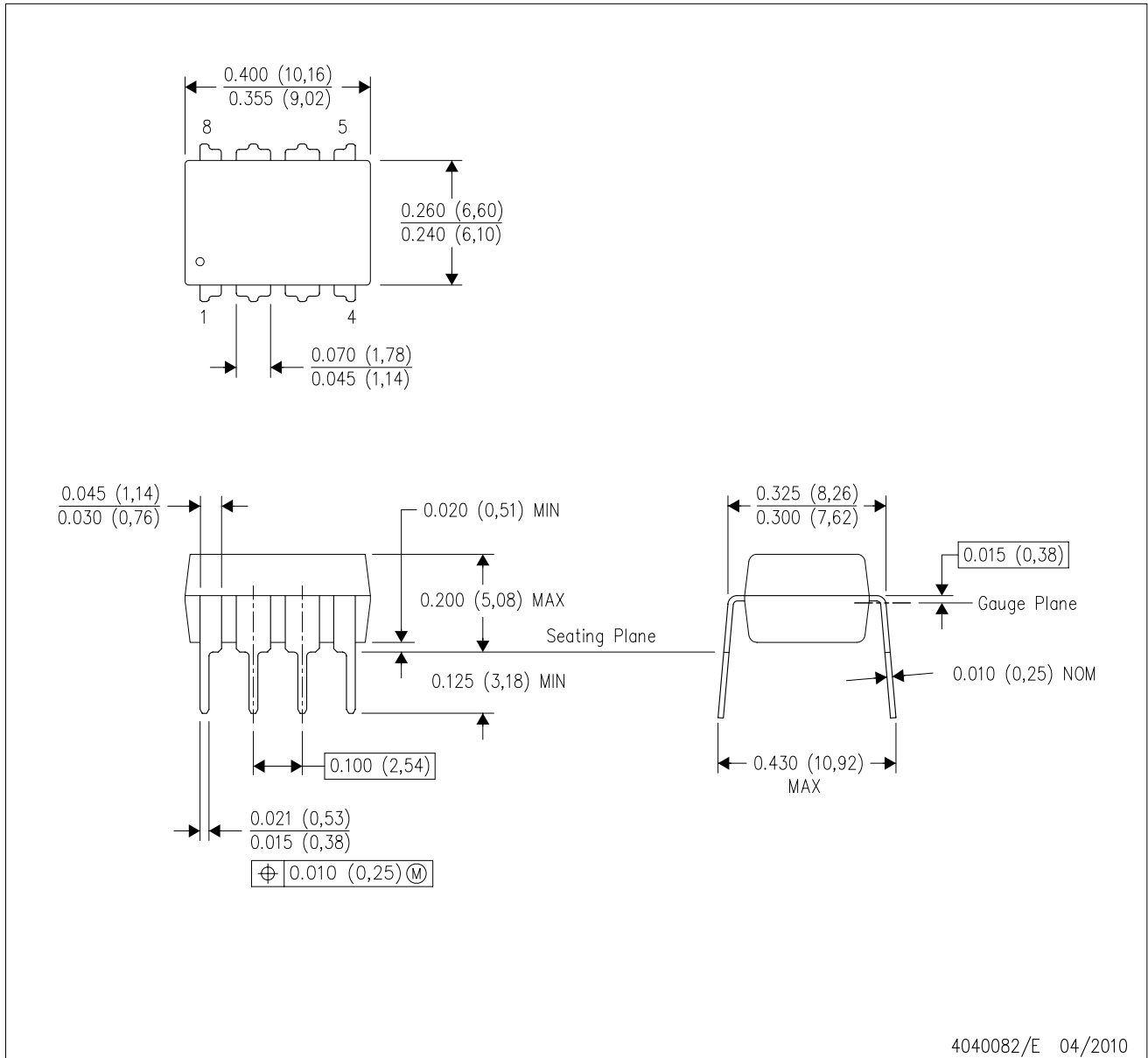

4040082/E 04/2010

- NOTES:
- All linear dimensions are in inches (millimeters).
  - This drawing is subject to change without notice.
  - Falls within JEDEC MS-001 variation BA.

NFF0014A

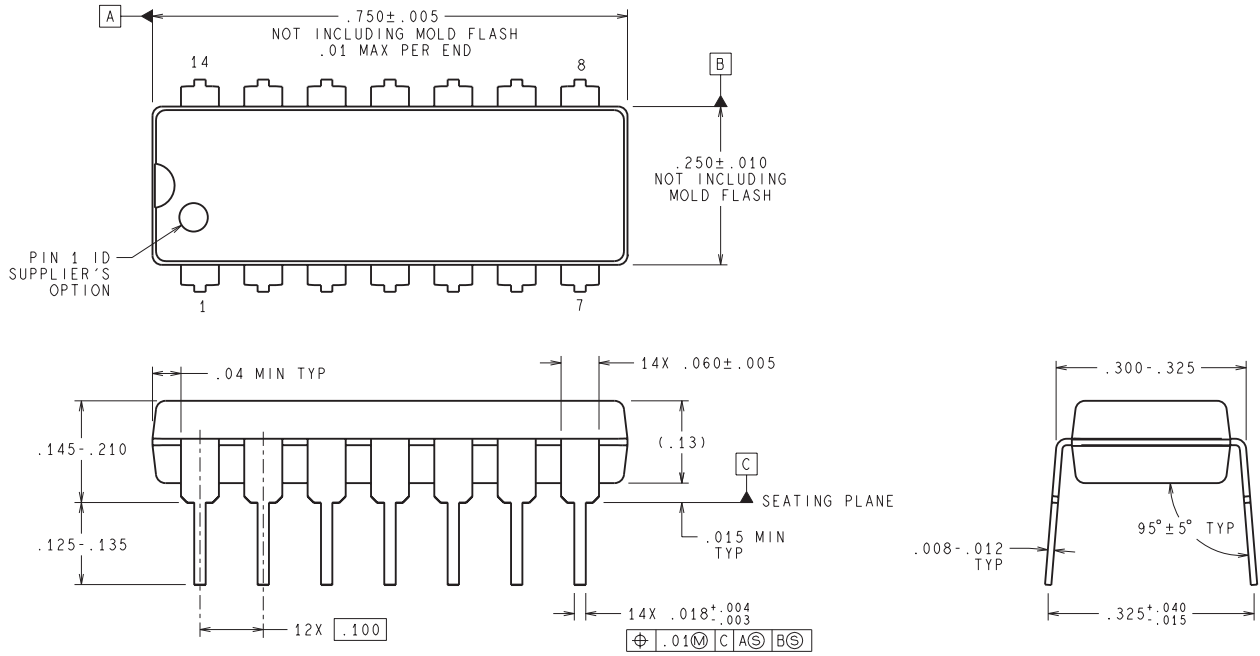

**DIMENSIONS ARE IN INCHES**  
DIMENSIONS IN ( ) FOR REFERENCE ONLY

N14A (Rev G)