

LM3880/-Q1 Simple Power Sequencer

1 Features

- Qualified for Automotive Applications
 - AEC-Q100 Grade 1 Qualified
 - Manufactured on an Automotive-Grade Flow
- Easiest Method to Sequence Rails
- Power-Up and Power-Down Control
- Tiny Footprint
- Low Quiescent Current of 25 μ A
- Input Voltage Range of 2.7 V to 5.5 V
- Standard Timing Options Available
- Customization of Timing and Sequence Available Through Factory Programmability

2 Applications

- Advanced Driver Assistance Systems (ADAS)
- Automotive Camera Modules
- Security Cameras
- Servers
- Networking Elements
- FPGA Sequencing
- Microprocessor and Microcontroller Sequencing
- Multiple Supply Sequencing

3 Description

The LM3880 Simple Power Sequencer offers the easiest method to control power up and power down sequencing of multiple Independent voltage rails. By staggering the startup sequence, it is possible to avoid latch conditions or large in-rush currents that can affect the reliability of the system.

Available in a 6-pin SOT-23-6 package, the Simple Sequencer contains a precision enable pin and three open-drain output flags. When the LM3880 is enabled, the three output flags will sequentially release, after individual time delays, thus permitting the connected power supplies to start up. The output flags will follow a reverse sequence during power down to avoid latch conditions.

EPROM capability allows every delay and sequence to be fully adjustable. Contact Texas Instruments if a nonstandard configuration is required.

Device Information⁽¹⁾

PART NUMBER	PACKAGE	BODY SIZE (NOM)
LM880	SOT (6)	2.90 mm x 1.60 mm
LM3880-Q1		

(1) For all available packages, see the orderable addendum at the end of the datasheet.

Typical System Application

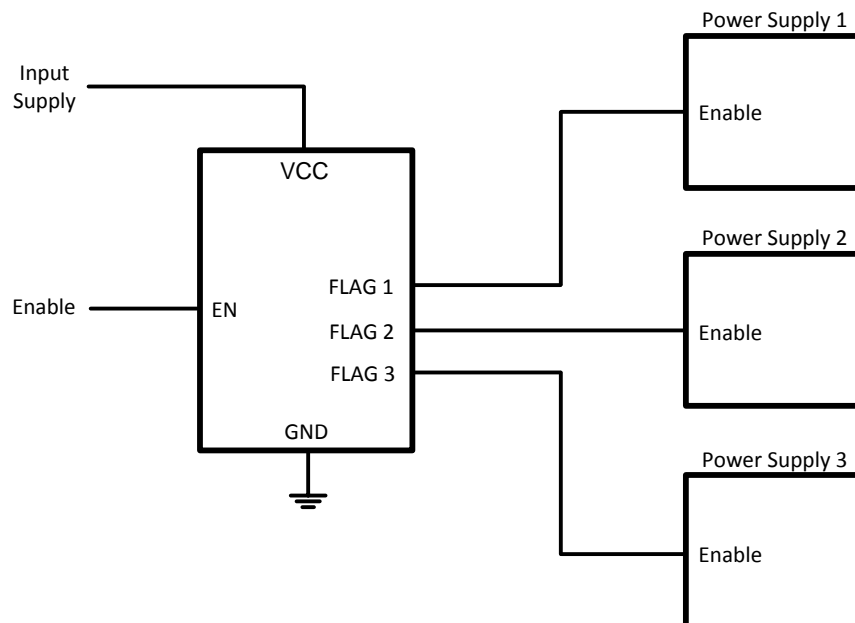

5 Pin Configuration and Functions

**6-Pin
SOT-23 Package
Top View**

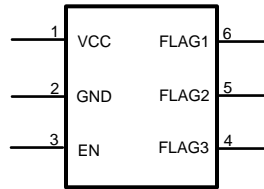

Pin Functions

PIN		DESCRIPTION
NAME	NO.	
VCC	1	Input supply
GND	2	Ground
EN	3	Precision enable pin
FLAG3	4	Open-drain output 3
FLAG2	5	Open-drain output 2
FLAG1	6	Open-drain output 1

6 Specifications

6.1 Absolute Maximum Ratings

over operating free-air temperature (unless otherwise noted) ⁽¹⁾⁽²⁾

	MIN	MAX	UNIT
VCC	-0.3	6.0	V
EN, FLAG1, FLAG2, FLAG3	-0.3	6.0	V
Max Flag ON Current		50	mA
Max Junction Temperature		150	°C
Lead Temperature (Soldering, 5 s)		260	°C

- (1) Stresses beyond those listed under *Absolute Maximum Ratings* may cause permanent damage to the device. These are stress ratings only, which do not imply functional operation of the device at these or any other conditions beyond those indicated under *Recommended Operating Conditions*. Exposure to absolute-maximum-rated conditions for extended periods may affect device reliability.
- (2) If Military/Aerospace specified devices are required, please contact the Texas Instruments Sales Office/Distributors for availability and specifications.

6.2 Handling Ratings LM3880

	MIN	MAX	UNIT
T _{stg}	Storage temperature range		°C
V _(ESD)	Electrostatic discharge	Human body model (HBM), per ANSI/ESDA/JEDEC JS-001, all pins ⁽¹⁾	kV

- (1) JEDEC document JEP155 states that 500-V HBM allows safe manufacturing with a standard ESD control process.

6.3 Handling Ratings LM3880-Q1

	MIN	MAX	UNIT
T _{stg}	Storage temperature range		°C
V _(ESD)	Electrostatic discharge	Human body model (HBM), per AEC Q100-002 ⁽¹⁾	kV

- (1) AEC Q100-002 indicates HBM stressing is done in accordance with the ANSI/ESDA/JEDEC JS-001 specification.

6.4 Recommended Operating Conditions

over operating free-air temperature range (unless otherwise noted)

	MIN	NOM	MAX	UNIT
VCC to GND	2.7		5.5	V
EN, FLAG1, FLAG2, FLAG3	-0.3		V _{CC} + 0.3	V
Junction Temperature	-40		125	°C

6.5 Thermal Information

THERMAL METRIC ⁽¹⁾		LM3880/ LM3880Q-1	UNIT
		DBV	
		6 PINS	
R _{θJA}	Junction-to-ambient thermal resistance	187.6	°C/W
R _{θJC(top)}	Junction-to-case (top) thermal resistance	127.4	
R _{θJB}	Junction-to-board thermal resistance	31.5	
Ψ _{JT}	Junction-to-top characterization parameter	23.3	
Ψ _{JB}	Junction-to-board characterization parameter	31.0	

- (1) For more information about traditional and new thermal metrics, see the *IC Package Thermal Metrics* application report, [SPRA953](#).

6.6 Electrical Characteristics

 $T_J = -40^{\circ}\text{C}$ to 125°C , over operating free-air temperature range (unless otherwise noted)

PARAMETER	TEST CONDITIONS	MIN ⁽¹⁾	TYP ⁽²⁾	MAX ⁽¹⁾	UNIT
I_Q	Operating Quiescent current		25	80	μA
OPEN-DRAIN FLAGS					
I_{FLAG}	FLAGx Leakage Current	$V_{\text{FLAGx}} = 3.3\text{ V}$	1	20	nA
V_{OL}	FLAGx Output Voltage Low	$I_{\text{FLAGx}} = 1.2\text{ mA}$		0.4	V
POWER-UP SEQUENCE					
t_{d1}	Timer delay 1 accuracy		-15%	15%	
		2 ms Timing Option	-20%	20%	
t_{d2}	Timer delay 2 accuracy		-15%	15%	
		2 ms Timing Option	-20%	20%	
t_{d3}	Timer delay 3 accuracy		-15%	15%	
		2 ms Timing Option	-20%	20%	
POWER-DOWN SEQUENCE					
t_{d4}	Timer delay 4 accuracy		-15%	15%	
		2 ms Timing Option	-20%	20%	
t_{d5}	Timer delay 5 accuracy		-15%	15%	
		2 ms Timing Option	-20%	20%	
t_{d6}	Timer delay 6 accuracy		-15%	15%	
		2 ms Timing Option	-20%	20%	
TIMING DELAY ERROR					
$(t_{d(x)} - 400\ \mu\text{s}) / t_{d(x+1)}$	Ratio of timing delays	For x = 1 or 4	95%	105%	
		For x = 1 or 4, 2 ms option	90%	110%	
$t_{d(x)} / t_{d(x+1)}$	Ratio of timing delays	For x = 2 or 5	95%	105%	
		For x = 2 or 5, 2 ms option	90%	110%	
ENABLE PIN					
V_{EN}	EN pin threshold		1.0	1.25	1.4
I_{EN}	EN pin pullup current	$V_{\text{EN}} = 0\text{ V}$	7		μA

- (1) Limits are 100% production tested at 25°. Limits over the operating temperature range are ensured through correlation using Statistical Quality Control (SQC) methods. The limits are used to calculate TI's Average Outgoing Quality Level (AOQL).
- (2) Typical numbers are at 25°C and represent the most likely parametric norm.

6.7 Timing Requirements

Table 1. Sequence Designator Table

SEQUENCE NUMBER	FLAG ORDER	
	POWER UP	POWER DOWN
1	1 - 2 - 3	3 - 2 - 1
2	1 - 2 - 3	3 - 1 - 2
3	1 - 2 - 3	2 - 3 - 1
4	1 - 2 - 3	2 - 1 - 3
5	1 - 2 - 3	1 - 3 - 2
6	1 - 2 - 3	1 - 2 - 3

Table 2. Timing Designator Table⁽¹⁾

TIMING DESIGNATOR	t _{d1}	t _{d2}	t _{d3}	t _{d4}	t _{d5}	t _{d6}
AF	16 ms	16 ms	16 ms	16 ms	16 ms	16 ms
AE	2 ms	2 ms	2 ms	2 ms	2 ms	2 ms
AA	10 ms	10 ms	10 ms	10 ms	10 ms	10 ms
AB	30 ms	30 ms	30 ms	30 ms	30 ms	30 ms
AC	60 ms	60 ms	60 ms	60 ms	60 ms	60 ms
AD	120 ms	120 ms	120 ms	120 ms	120 ms	120 ms

(1) See timing diagrams for more information

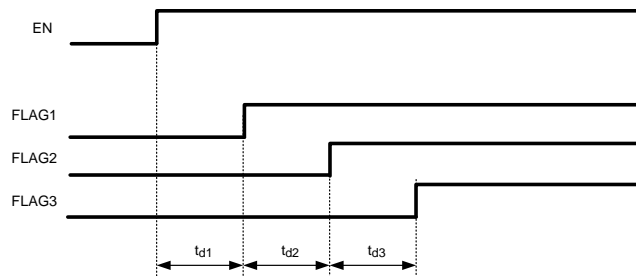

Sequence 1: All standard options use this sequence for output flags rise and fall order.

Figure 1. Power-Up Sequence

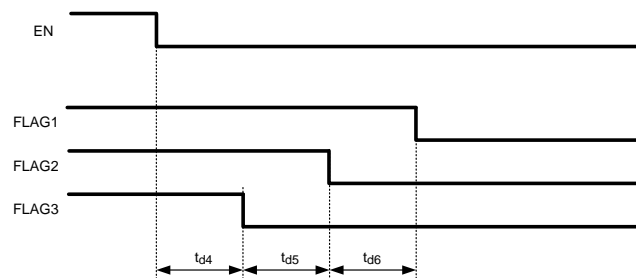

Sequence 1: All standard options use this sequence for output flags rise and fall order.

Figure 2. Power-Down Sequence

6.8 Typical Characteristics

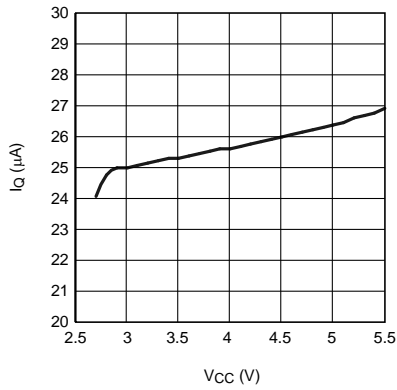

Figure 3. Quiescent Current vs VCC

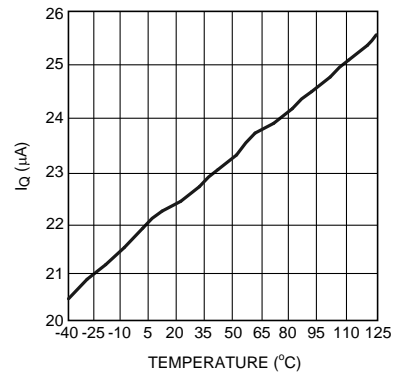

Figure 4. Quiescent Current vs Temperature (VCC = 3.3 V)

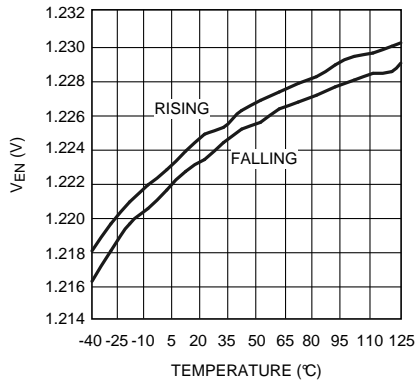

Figure 5. Enable Threshold vs Temperature

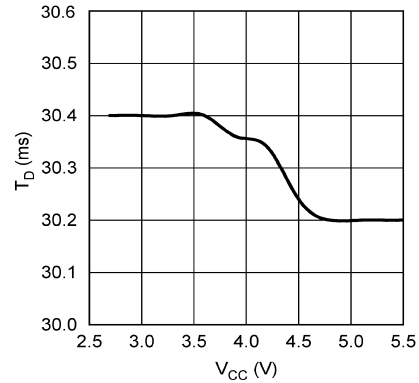

Figure 6. Time Delay (30 ms) vs Vcc

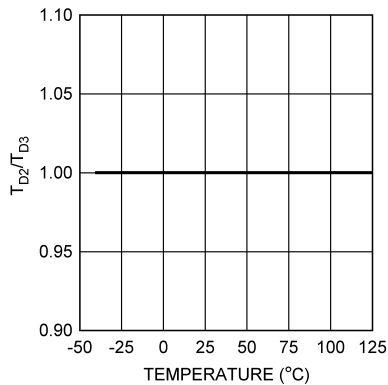

Figure 7. Time Delay Ratio vs Temperature

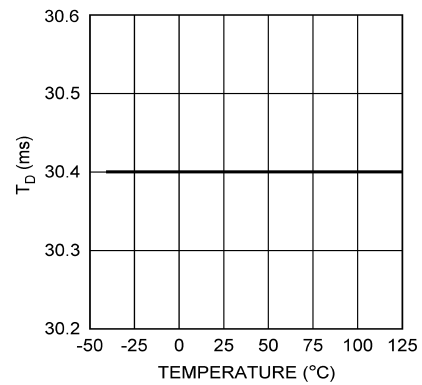

Figure 8. Time Delay (30 ms) vs Temperature

Typical Characteristics (continued)

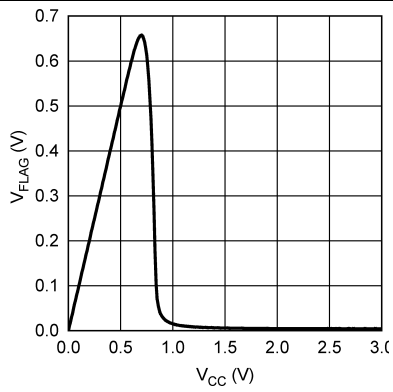

Figure 9. Flag V_{OL} vs V_{CC} ($R_{FLAG} = 100\text{ k}\Omega$)

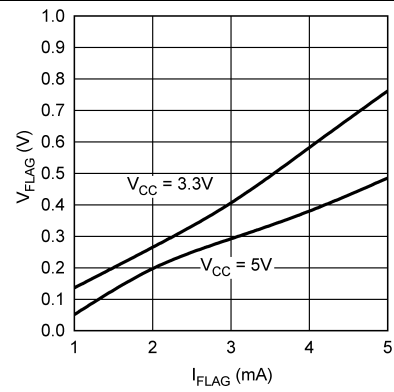

Figure 10. Flag Voltage vs Current

7 Detailed Description

7.1 Overview

The LM3880 Simple Power Sequencer provides a simple solution for sequencing multiple rails in a controlled manner. Six independent timers are integrated to control the timing sequence (power up and power down) of three open-drain output flags. These flags permit connection to either a shutdown or enable pin of linear regulators and switchers to control the operation of the power supplies. This allows design of a complete power system without concern for large inrush currents or latch-up conditions that can occur.

The timing sequence of the LM3880 is controlled entirely by the enable (EN) pin. Upon power up, all the flags are held low until this precision enable is pulled high. When the EN pin is asserted, the power-up sequence starts. An internal counter delays the first flag (FLAG1) from rising until a fixed time period has expired. When the first flag is released, another timer will begin to delay the release of the second flag (FLAG2). This process repeats until all three flags have sequentially been released. The three timers that control the delays are independent of each other and can be individually programmed if needed. (See the [Customized Timing and Sequencing](#) section.)

The power-down sequence is the same as power-up sequence, but in reverse. When the EN pin is deasserted a timer will begin that delays the third flag (FLAG3) from pulling low. The second and first flag will then follow in a sequential manner after their appropriate delays. The three timers that are used to control the power-down scheme can also be individually programmed and are completely independent of the power-up timers.

Additional sequence patterns are also available in addition to customizable timers. For more information, see the [Customized Timing and Sequencing](#) section.

7.2 Functional Block Diagram

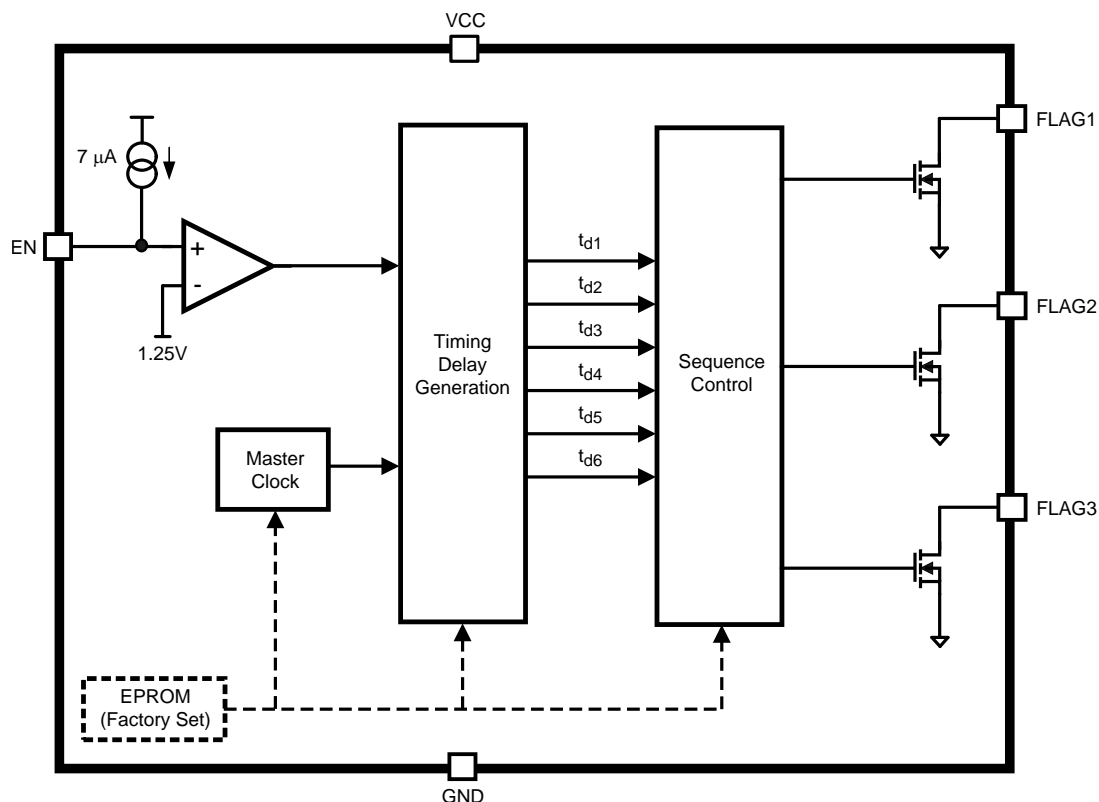

7.3 Feature Description

7.3.1 Enable Pin Operation

The timing sequence of the LM3880 is controlled by the assertion of the enable signal. The enable pin is designed with an internal comparator, referenced to a bandgap voltage (1.25 V), to provide a precision threshold. This allows a delayed timing to be externally set using a capacitor or to start the sequencing based on a certain event, such as a line voltage reaching 90% of nominal. For an additional delayed sequence from the rail powering VCC, simply attach a capacitor to the EN pin as shown in [Figure 11](#).

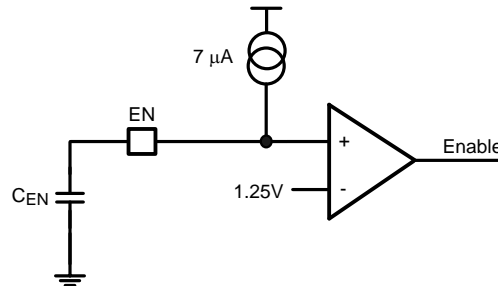

Figure 11. Capacitor Timing

Using the internal pullup current source to charge the external capacitor (C_{EN}) the enable pin delay can be calculated by [Equation 1](#):

$$t_{enable_delay} = \frac{1.25V \times C_{EN}}{7 \mu A} \quad (1)$$

A resistor divider can also be used to enable the LM3880 based on a certain voltage threshold. Take care when sizing the resistor divider to include the effects of the internal current source.

One of the features of the EN pin is that it provides glitch free operation. The first timer will start counting at a rising threshold, but will always reset if the EN pin is deasserted before the first output flag is released. This can be shown in [Figure 12](#):

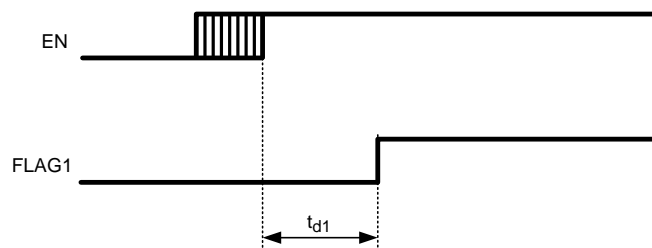

Figure 12. EN Glitch

7.3.2 Incomplete Sequence Operation

If the enable signal remains high for the entire power-up sequence, then the part will operate as shown in the standard timing diagrams. However, if the enable signal is de-asserted before the power-up sequence is completed the part will enter a controlled shutdown. This allows the system to walk through a controlled power cycling, preventing any latch conditions from occurring. This state only occurs if the enable pin is deasserted after the completion of timer 1, but before the entire power-up sequence is completed.

Feature Description (continued)

When this event occurs, the falling edge of EN pin resets the current timer and will allow the remaining power-up cycle to complete before beginning the power-down sequence. The power down sequence starts approximately 120 ms after the final power-up flag. This allows output voltages in the system to stabilize before everything is shut down. An example of this operation can be seen in [Figure 13](#):

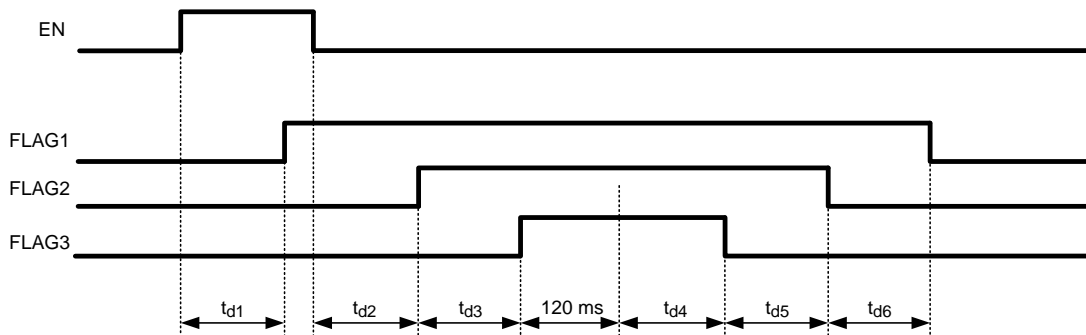

Figure 13. Incomplete Power-Up Sequence

When the enable signal is deasserted, the part will commence its power-down sequence. If the enable signal is pulled high before the power-down sequence is completed, the part will ensure completion of the power-down sequence before starting power-up. This ensures that the system does not partially power down and power up and helps prevent latch-up events, such as in FPGAs and microprocessors. This state only occurs if the enable pin is pulled high after the completion of timer 1, but before the entire power-down sequence is completed.

When this event occurs, the rising edge of enable pin resets the current timer and will allow the remaining power-down cycle to complete before beginning the power-up sequence. The power-up sequence starts approximately 120 ms after the final power-down flag. This allows the system to fully shut down before it is powered up. An example of this operation can be seen in [Figure 14](#):

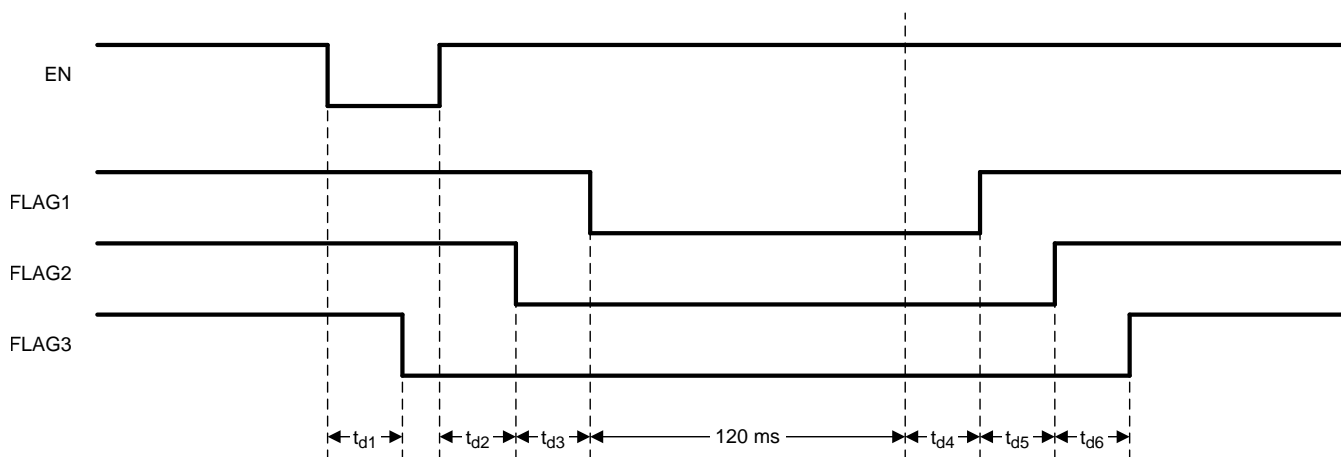

Figure 14. Incomplete Power-Down Sequence

All the internal timers are generated by a master clock that has an extremely low tempco. This allows for tight accuracy across temperature and a consistent ratio between the individual timers. There is a slight additional delay of approximately 400 μ s to timers 1 and 4, which is a result of the EPROM refresh. This refresh time is in addition to the programmed delay time and will be almost insignificant to all but the shortest of timer delays.

Feature Description (continued)

7.3.3 Customized Timing and Sequencing

The LM3880 Simple Power Sequencer is based on a CMOS process using an EPROM that can be custom programmed at the factory. Approximately 500,000,000 different options are available allowing even the most complex system to be simply sequenced. Because of the vast options that are possible, customization is limited to orders of a certain quantity. For more information, please contact Texas Instruments.

The variables that can be programmed include the six delay timers and the reverse sequence order. For the timers, each can be individually selected from one of the timer selector columns in [Table 3](#). However, all six time delays must be from the same column.

Table 3. Timer Options

TIMER OPTIONS 1 ⁽¹⁾	TIMER OPTIONS 2 ⁽¹⁾	TIMER OPTIONS 3 ⁽¹⁾	TIMER OPTIONS 4 ⁽¹⁾
0	0	0	0
2	4	6	8
4	8	12	16
6	12	18	24
8	16	24	32
10	20	30	40
12	24	36	48
14	28	42	56
16	32	48	64
18	36	54	72
20	40	60	80
22	44	66	88
24	48	72	96
26	52	78	104
28	56	84	112
30	60	90	120

(1) All times listed are in milliseconds

The sequencing order for power up is always controlled by layout. The flag number translates directly into the sequence order during power up (that is, FLAG1 will always be first). However, for some systems a different power down order could be required. To allow flexibility for this aspect in a design, the Simple Power Sequencer incorporates six different options for controlling the power-down sequence. These options can be seen in [Figure 16](#) and [Figure 17](#). This ability can be programmed in addition to the custom timers.

7.4 Device Functional Modes

7.4.1 Power Up With EN Pin

The timing sequence of the Simple Power Sequencer is controlled entirely by the enable (EN) pin. Upon power up, all the flags are held low until this precision enable is pulled high. After the EN pin is asserted, the power-up sequence will commence.

7.4.2 Power Down With EN Pin

When EN pin is deasserted, the power down sequence will commence. A timer will begin that delays the third flag (FLAG3) from pulling low. The second and first flag will then follow in a sequential manner after their appropriate delays.

8 Application and Implementation

NOTE

Information in the following applications sections is not part of the TI component specification, and TI does not warrant its accuracy or completeness. TI's customers are responsible for determining suitability of components for their purposes. Customers should validate and test their design implementation to confirm system functionality.

8.1 Application Information

8.1.1 Open Drain Flags Pullup

The Simple Power Sequencer contains three open-drain output flags which need to be pulled up for proper operation. 100-k Ω resistors can be used as pullup resistors.

8.1.2 Enable the Device

See [Enable Pin Operation](#).

8.2 Typical Application

8.2.1 Simple Sequencing of Three Power Supplies

The Simple Power Sequencer is used to implement a power-up (1 - 2 - 3) and power-down (3 - 2 - 1) sequence of three power supplies.

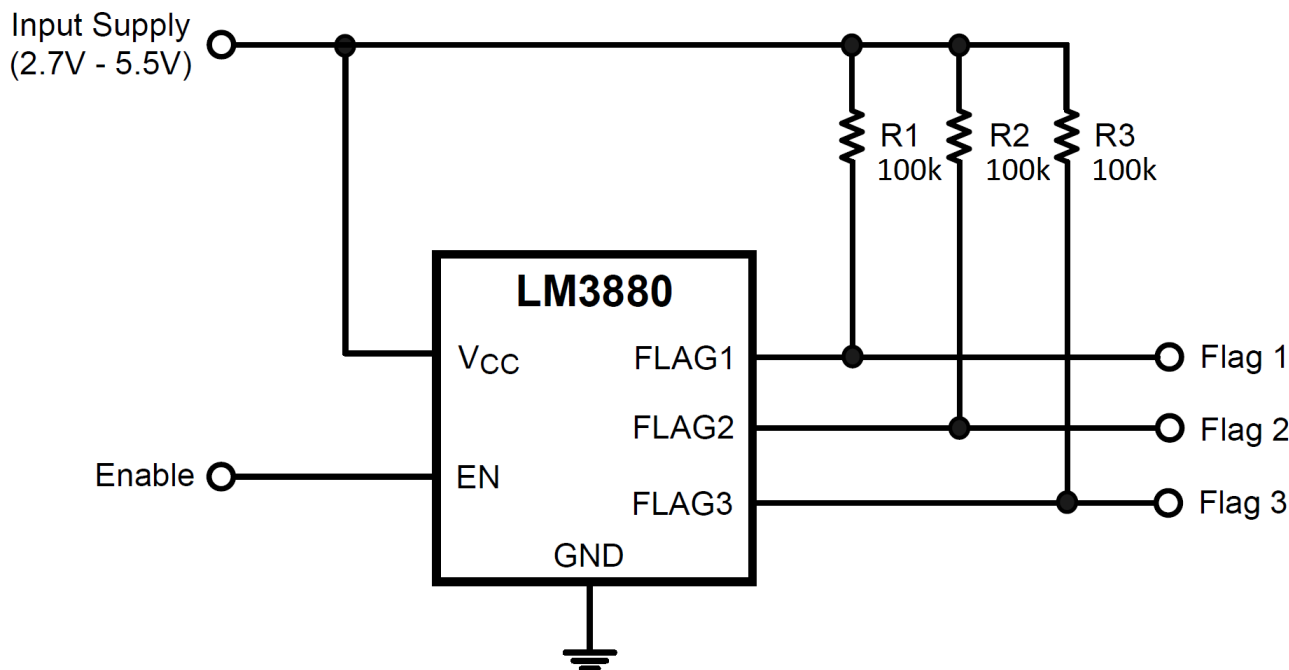

Figure 15. Typical Application Circuit

Typical Application (continued)

8.2.1.1 Design Requirements

For this design example, use the parameters listed in [Table 4](#) as the input parameters.

Table 4. Design Parameters

Design Parameter	Example Value
Input Supply voltage range	2.7 V to 5.5 V
Flag Output voltage, EN high	Input Supply
Flag Output voltage, EN low	0 V
Flag Timing Delay	30 ms
Power-Up Sequence	1 - 2 - 3
Power-Down Sequence	3 - 2 - 1

8.2.1.2 Detailed Design Procedure

Table 5. Bill of Materials

Designator	Description	Part #	Quantity	Manufacturer
U1	LM3880, Sequence 1, 30 ms timing	LM3880	1	Texas Instruments
R1	100K Resistor, 0603	CRCW0603100KFKEA	1	Vishay
R2	100K Resistor, 0603	CRCW0603100KFKEA	1	Vishay
R3	100K Resistor, 0603	CRCW0603100KFKEA	1	Vishay

This application uses the Sequence 1 and 30-ms timing options of the Simple Power Sequencer. See [Timing Requirements](#) for details on the sequence and timing option.

8.2.1.3 Application Curves

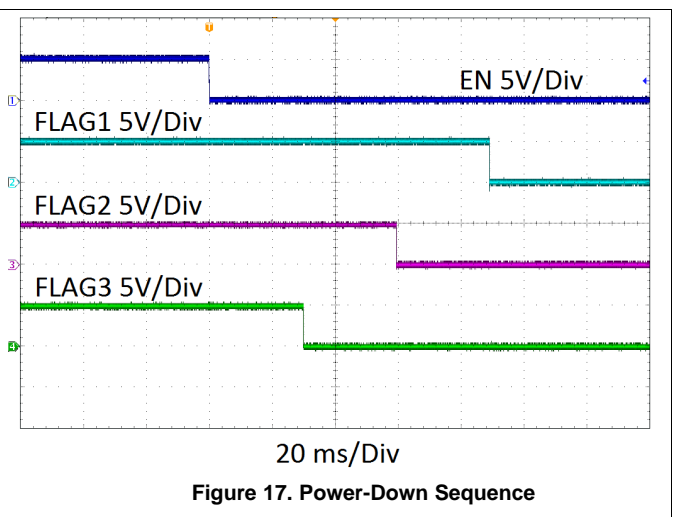
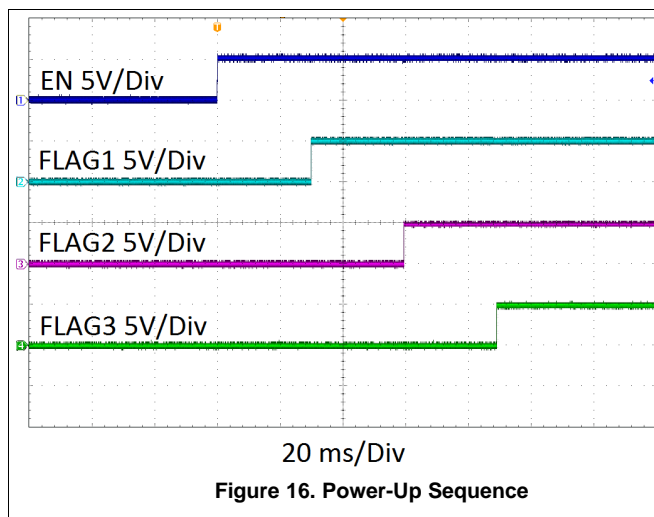

8.2.2 Sequencing Using Independent Flag Supply

For applications requiring a flag output voltage that is different from the VCC, a separate Flag Supply may be used to pullup the open-drain outputs of the Simple Power Sequencer. This is useful when interfacing the flag outputs with inputs that require a different voltage than VCC. The designer must ensure the Flag Supply voltage is within the range specified in the *Recommended Operating Conditions*.

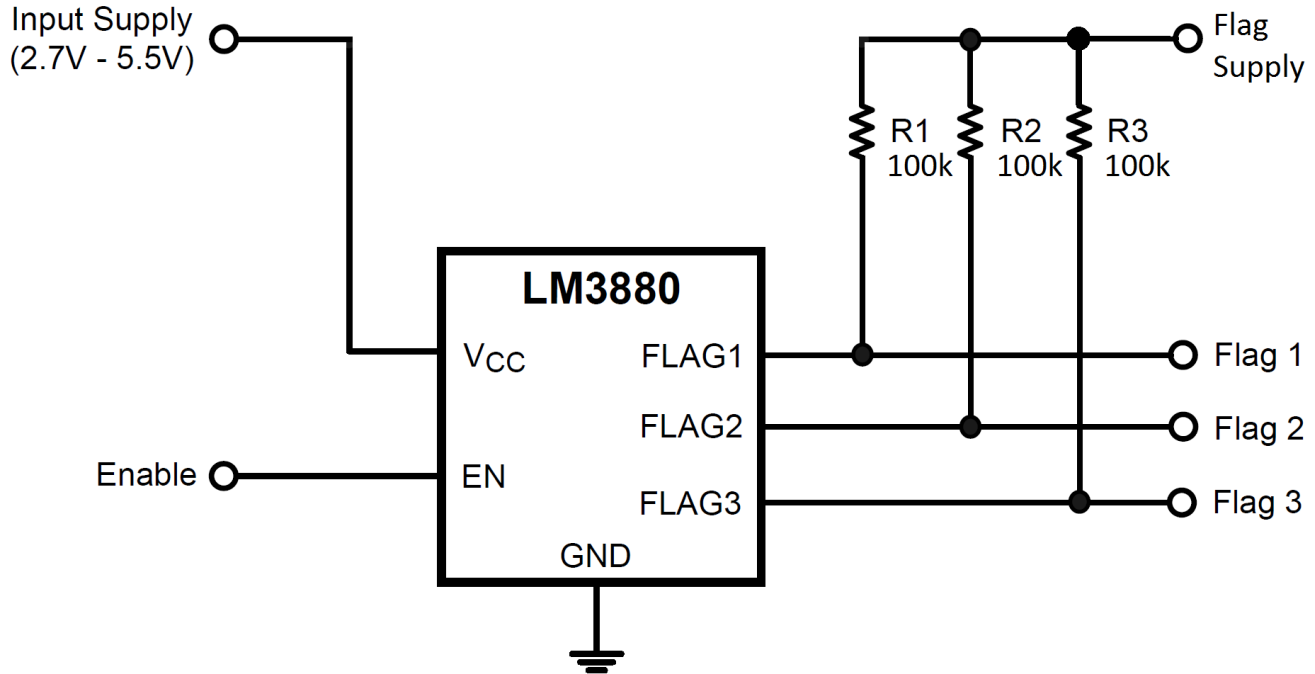

Figure 18. Sequencing Using Independent Flag Supply

9 Power Supply Recommendations

The VCC pin should be located as close as possible to the input supply (2.7V - 5.5V). An input capacitor is not required but is recommended when noise might be present on the VCC pin. A 0.1 μ F ceramic capacitor may be used to bypass this noise.

10 Layout

10.1 Layout Guidelines

- Pullup resistors should be connected between the flag output pins and a positive input supply, usually VCC. An independent flag supply may also be used. These resistors should be placed as close as possible to the Simple Power Sequencer and the flag supply. Minimal trace length is recommended to make the connections. A typical value for the pullup resistors is 100k Ω .
- For very tight sequencing requirements, minimal and equal trace lengths should be used to connect the flag outputs to the desired inputs. This will reduce any propagation delay and timing errors between the flag outputs along the line.

10.2 Layout Example

Figure 19 and Figure 20 are layout examples for the LM3880/LM3880-Q1. These examples are taken from the LM3880EVAL.

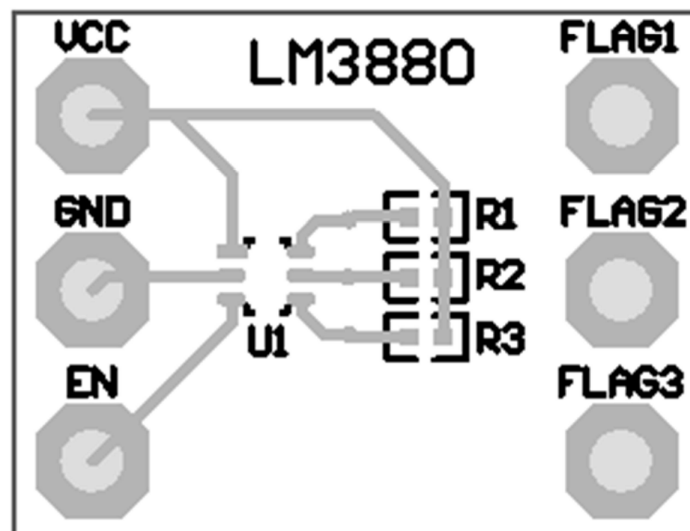

Figure 19. LM3880 Top

Layout Example (continued)

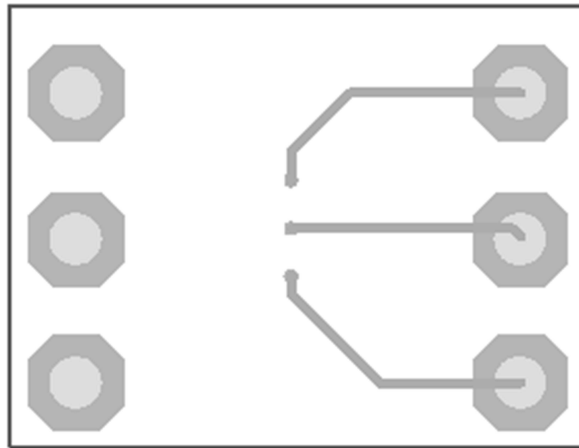

Figure 20. LM3880 Bottom

11 Device and Documentation Support

11.1 Device Support

11.1.1 Third-Party Products Disclaimer

TI'S PUBLICATION OF INFORMATION REGARDING THIRD-PARTY PRODUCTS OR SERVICES DOES NOT CONSTITUTE AN ENDORSEMENT REGARDING THE SUITABILITY OF SUCH PRODUCTS OR SERVICES OR A WARRANTY, REPRESENTATION OR ENDORSEMENT OF SUCH PRODUCTS OR SERVICES, EITHER ALONE OR IN COMBINATION WITH ANY TI PRODUCT OR SERVICE.

11.2 Related Links

The table below lists quick access links. Categories include technical documents, support and community resources, tools and software, and quick access to sample or buy.

Table 6. Related Links

PARTS	PRODUCT FOLDER	SAMPLE & BUY	TECHNICAL DOCUMENTS	TOOLS & SOFTWARE	SUPPORT & COMMUNITY
LM3880	Click here	Click here	Click here	Click here	Click here
LM3880-Q1	Click here	Click here	Click here	Click here	Click here

11.3 Trademarks

All trademarks are the property of their respective owners.

11.4 Electrostatic Discharge Caution



These devices have limited built-in ESD protection. The leads should be shorted together or the device placed in conductive foam during storage or handling to prevent electrostatic damage to the MOS gates.

11.5 Glossary

[SLYZ022](#) — *TI Glossary*.

This glossary lists and explains terms, acronyms, and definitions.



12 Mechanical, Packaging, and Orderable Information

The following pages include mechanical, packaging, and orderable information. This information is the most current data available for the designated devices. This data is subject to change without notice and revision of this document. For browser-based versions of this data sheet, refer to the left-hand navigation.

PACKAGING INFORMATION

Orderable Device	Status (1)	Package Type	Package Drawing	Pins	Package Qty	Eco Plan (2)	Lead/Ball Finish (6)	MSL Peak Temp (3)	Op Temp (°C)	Device Marking (4/5)	Samples
LM3880MF-1AA	NRND	SOT-23	DBV	6	1000	TBD	Call TI	Call TI	-40 to 125	F20A	
LM3880MF-1AA/NOPB	ACTIVE	SOT-23	DBV	6	1000	Green (RoHS & no Sb/Br)	CU SN	Level-1-260C-UNLIM	-40 to 125	F20A	Samples
LM3880MF-1AB/NOPB	ACTIVE	SOT-23	DBV	6	1000	Green (RoHS & no Sb/Br)	CU SN	Level-1-260C-UNLIM	-40 to 125	F21A	Samples
LM3880MF-1AC/NOPB	ACTIVE	SOT-23	DBV	6	1000	Green (RoHS & no Sb/Br)	CU SN	Level-1-260C-UNLIM	-40 to 125	F22A	Samples
LM3880MF-1AD/NOPB	ACTIVE	SOT-23	DBV	6	1000	Green (RoHS & no Sb/Br)	CU SN	Level-1-260C-UNLIM	-40 to 125	F23A	Samples
LM3880MF-1AE/NOPB	ACTIVE	SOT-23	DBV	6	1000	Green (RoHS & no Sb/Br)	CU SN	Level-1-260C-UNLIM	-40 to 125	F25A	Samples
LM3880MF-1AF/NOPB	ACTIVE	SOT-23	DBV	6	1000	Green (RoHS & no Sb/Br)	CU SN	Level-1-260C-UNLIM	-40 to 125	F31A	Samples
LM3880MFE-1AA/NOPB	ACTIVE	SOT-23	DBV	6	250	Green (RoHS & no Sb/Br)	CU SN	Level-1-260C-UNLIM	-40 to 125	F20A	Samples
LM3880MFE-1AB/NOPB	ACTIVE	SOT-23	DBV	6	250	Green (RoHS & no Sb/Br)	CU SN	Level-1-260C-UNLIM	-40 to 125	F21A	Samples
LM3880MFE-1AC/NOPB	ACTIVE	SOT-23	DBV	6	250	Green (RoHS & no Sb/Br)	CU SN	Level-1-260C-UNLIM	-40 to 125	F22A	Samples
LM3880MFE-1AD/NOPB	ACTIVE	SOT-23	DBV	6	250	Green (RoHS & no Sb/Br)	CU SN	Level-1-260C-UNLIM	-40 to 125	F23A	Samples
LM3880MFE-1AE/NOPB	ACTIVE	SOT-23	DBV	6	250	Green (RoHS & no Sb/Br)	CU SN	Level-1-260C-UNLIM	-40 to 125	F25A	Samples
LM3880MFE-1AF/NOPB	ACTIVE	SOT-23	DBV	6	250	Green (RoHS & no Sb/Br)	CU SN	Level-1-260C-UNLIM	-40 to 125	F31A	Samples
LM3880MFX-1AA/NOPB	ACTIVE	SOT-23	DBV	6	3000	Green (RoHS & no Sb/Br)	CU SN	Level-1-260C-UNLIM	-40 to 125	F20A	Samples
LM3880MFX-1AB/NOPB	ACTIVE	SOT-23	DBV	6	3000	Green (RoHS & no Sb/Br)	CU SN	Level-1-260C-UNLIM	-40 to 125	F21A	Samples
LM3880MFX-1AC/NOPB	ACTIVE	SOT-23	DBV	6	3000	Green (RoHS & no Sb/Br)	CU SN	Level-1-260C-UNLIM	-40 to 125	F22A	Samples
LM3880MFX-1AD/NOPB	ACTIVE	SOT-23	DBV	6	3000	Green (RoHS & no Sb/Br)	CU SN	Level-1-260C-UNLIM	-40 to 125	F23A	Samples

Orderable Device	Status (1)	Package Type	Package Drawing	Pins	Package Qty	Eco Plan (2)	Lead/Ball Finish (6)	MSL Peak Temp (3)	Op Temp (°C)	Device Marking (4/5)	Samples
LM3880MFX-1AE/NOPB	ACTIVE	SOT-23	DBV	6	3000	Green (RoHS & no Sb/Br)	CU SN	Level-1-260C-UNLIM	-40 to 125	F25A	Samples
LM3880MFX-1AF/NOPB	ACTIVE	SOT-23	DBV	6	3000	Green (RoHS & no Sb/Br)	CU SN	Level-1-260C-UNLIM	-40 to 125	F31A	Samples
LM3880QMF-1AA/NOPB	ACTIVE	SOT-23	DBV	6	1000	Green (RoHS & no Sb/Br)	CU SN	Level-1-260C-UNLIM	-40 to 125	F27A	Samples
LM3880QMF-1AB/NOPB	ACTIVE	SOT-23	DBV	6	1000	Green (RoHS & no Sb/Br)	CU SN	Level-1-260C-UNLIM	-40 to 125	F28A	Samples
LM3880QMF-1AC/NOPB	ACTIVE	SOT-23	DBV	6	1000	Green (RoHS & no Sb/Br)	CU SN	Level-1-260C-UNLIM	-40 to 125	F29A	Samples
LM3880QMF-1AD/NOPB	ACTIVE	SOT-23	DBV	6	1000	Green (RoHS & no Sb/Br)	CU SN	Level-1-260C-UNLIM	-40 to 125	F30A	Samples
LM3880QMF-1AE/NOPB	ACTIVE	SOT-23	DBV	6	1000	Green (RoHS & no Sb/Br)	CU SN	Level-1-260C-UNLIM	-40 to 125	F24A	Samples
LM3880QMF-1AF/NOPB	ACTIVE	SOT-23	DBV	6	1000	Green (RoHS & no Sb/Br)	CU SN	Level-1-260C-UNLIM	-40 to 125	F32A	Samples
LM3880QMFE-1AA/NOPB	ACTIVE	SOT-23	DBV	6	250	Green (RoHS & no Sb/Br)	CU SN	Level-1-260C-UNLIM	-40 to 125	F27A	Samples
LM3880QMFE-1AB/NOPB	ACTIVE	SOT-23	DBV	6	250	Green (RoHS & no Sb/Br)	CU SN	Level-1-260C-UNLIM	-40 to 125	F28A	Samples
LM3880QMFE-1AC/NOPB	ACTIVE	SOT-23	DBV	6	250	Green (RoHS & no Sb/Br)	CU SN	Level-1-260C-UNLIM	-40 to 125	F29A	Samples
LM3880QMFE-1AD/NOPB	ACTIVE	SOT-23	DBV	6	250	Green (RoHS & no Sb/Br)	CU SN	Level-1-260C-UNLIM	-40 to 125	F30A	Samples
LM3880QMFE-1AE/NOPB	ACTIVE	SOT-23	DBV	6	250	Green (RoHS & no Sb/Br)	CU SN	Level-1-260C-UNLIM	-40 to 125	F24A	Samples
LM3880QMFE-1AF/NOPB	ACTIVE	SOT-23	DBV	6	250	Green (RoHS & no Sb/Br)	CU SN	Level-1-260C-UNLIM	-40 to 125	F32A	Samples
LM3880MFX-1AA/NOPB	ACTIVE	SOT-23	DBV	6	3000	Green (RoHS & no Sb/Br)	CU SN	Level-1-260C-UNLIM	-40 to 125	F27A	Samples
LM3880MFX-1AB/NOPB	ACTIVE	SOT-23	DBV	6	3000	Green (RoHS & no Sb/Br)	CU SN	Level-1-260C-UNLIM	-40 to 125	F28A	Samples
LM3880MFX-1AC/NOPB	ACTIVE	SOT-23	DBV	6	3000	Green (RoHS & no Sb/Br)	CU SN	Level-1-260C-UNLIM	-40 to 125	F29A	Samples
LM3880MFX-1AD/NOPB	ACTIVE	SOT-23	DBV	6	3000	Green (RoHS & no Sb/Br)	CU SN	Level-1-260C-UNLIM	-40 to 125	F30A	Samples

Orderable Device	Status (1)	Package Type	Package Drawing	Pins	Package Qty	Eco Plan (2)	Lead/Ball Finish (6)	MSL Peak Temp (3)	Op Temp (°C)	Device Marking (4/5)	Samples
LM3880QMFx-1AE/NOPB	ACTIVE	SOT-23	DBV	6	3000	Green (RoHS & no Sb/Br)	CU SN	Level-1-260C-UNLIM	-40 to 125	F24A	
LM3880QMFx-1AF/NOPB	ACTIVE	SOT-23	DBV	6	3000	Green (RoHS & no Sb/Br)	CU SN	Level-1-260C-UNLIM	-40 to 125	F32A	

(1) The marketing status values are defined as follows:

ACTIVE: Product device recommended for new designs.

LIFEBUY: TI has announced that the device will be discontinued, and a lifetime-buy period is in effect.

NRND: Not recommended for new designs. Device is in production to support existing customers, but TI does not recommend using this part in a new design.

PREVIEW: Device has been announced but is not in production. Samples may or may not be available.

OBSELETE: TI has discontinued the production of the device.

(2) Eco Plan - The planned eco-friendly classification: Pb-Free (RoHS), Pb-Free (RoHS Exempt), or Green (RoHS & no Sb/Br) - please check <http://www.ti.com/productcontent> for the latest availability information and additional product content details.

TBD: The Pb-Free/Green conversion plan has not been defined.

Pb-Free (RoHS): TI's terms "Lead-Free" or "Pb-Free" mean semiconductor products that are compatible with the current RoHS requirements for all 6 substances, including the requirement that lead not exceed 0.1% by weight in homogeneous materials. Where designed to be soldered at high temperatures, TI Pb-Free products are suitable for use in specified lead-free processes.

Pb-Free (RoHS Exempt): This component has a RoHS exemption for either 1) lead-based flip-chip solder bumps used between the die and package, or 2) lead-based die adhesive used between the die and leadframe. The component is otherwise considered Pb-Free (RoHS compatible) as defined above.

Green (RoHS & no Sb/Br): TI defines "Green" to mean Pb-Free (RoHS compatible), and free of Bromine (Br) and Antimony (Sb) based flame retardants (Br or Sb do not exceed 0.1% by weight in homogeneous material)

(3) MSL, Peak Temp. - The Moisture Sensitivity Level rating according to the JEDEC industry standard classifications, and peak solder temperature.

(4) There may be additional marking, which relates to the logo, the lot trace code information, or the environmental category on the device.

(5) Multiple Device Markings will be inside parentheses. Only one Device Marking contained in parentheses and separated by a "~" will appear on a device. If a line is indented then it is a continuation of the previous line and the two combined represent the entire Device Marking for that device.

(6) Lead/Ball Finish - Orderable Devices may have multiple material finish options. Finish options are separated by a vertical ruled line. Lead/Ball Finish values may wrap to two lines if the finish value exceeds the maximum column width.

Important Information and Disclaimer: The information provided on this page represents TI's knowledge and belief as of the date that it is provided. TI bases its knowledge and belief on information provided by third parties, and makes no representation or warranty as to the accuracy of such information. Efforts are underway to better integrate information from third parties. TI has taken and continues to take reasonable steps to provide representative and accurate information but may not have conducted destructive testing or chemical analysis on incoming materials and chemicals. TI and TI suppliers consider certain information to be proprietary, and thus CAS numbers and other limited information may not be available for release.

In no event shall TI's liability arising out of such information exceed the total purchase price of the TI part(s) at issue in this document sold by TI to Customer on an annual basis.

OTHER QUALIFIED VERSIONS OF LM3880, LM3880-Q1 :

- Catalog: [LM3880](#)
- Automotive: [LM3880-Q1](#)

NOTE: Qualified Version Definitions:

- Catalog - TI's standard catalog product
- Automotive - Q100 devices qualified for high-reliability automotive applications targeting zero defects

TAPE AND REEL INFORMATION

QUADRANT ASSIGNMENTS FOR PIN 1 ORIENTATION IN TAPE

*All dimensions are nominal

Device	Package Type	Package Drawing	Pins	SPQ	Reel Diameter (mm)	Reel Width W1 (mm)	A0 (mm)	B0 (mm)	K0 (mm)	P1 (mm)	W (mm)	Pin1 Quadrant
LM3880MF-1AA	SOT-23	DBV	6	1000	178.0	8.4	3.2	3.2	1.4	4.0	8.0	Q3
LM3880MF-1AA/NOPB	SOT-23	DBV	6	1000	178.0	8.4	3.2	3.2	1.4	4.0	8.0	Q3
LM3880MF-1AB/NOPB	SOT-23	DBV	6	1000	178.0	8.4	3.2	3.2	1.4	4.0	8.0	Q3
LM3880MF-1AC/NOPB	SOT-23	DBV	6	1000	178.0	8.4	3.2	3.2	1.4	4.0	8.0	Q3
LM3880MF-1AD/NOPB	SOT-23	DBV	6	1000	178.0	8.4	3.2	3.2	1.4	4.0	8.0	Q3
LM3880MF-1AE/NOPB	SOT-23	DBV	6	1000	178.0	8.4	3.2	3.2	1.4	4.0	8.0	Q3
LM3880MF-1AF/NOPB	SOT-23	DBV	6	1000	178.0	8.4	3.2	3.2	1.4	4.0	8.0	Q3
LM3880MFE-1AA/NOPB	SOT-23	DBV	6	250	178.0	8.4	3.2	3.2	1.4	4.0	8.0	Q3
LM3880MFE-1AB/NOPB	SOT-23	DBV	6	250	178.0	8.4	3.2	3.2	1.4	4.0	8.0	Q3
LM3880MFE-1AC/NOPB	SOT-23	DBV	6	250	178.0	8.4	3.2	3.2	1.4	4.0	8.0	Q3
LM3880MFE-1AD/NOPB	SOT-23	DBV	6	250	178.0	8.4	3.2	3.2	1.4	4.0	8.0	Q3
LM3880MFE-1AE/NOPB	SOT-23	DBV	6	250	178.0	8.4	3.2	3.2	1.4	4.0	8.0	Q3
LM3880MFE-1AF/NOPB	SOT-23	DBV	6	250	178.0	8.4	3.2	3.2	1.4	4.0	8.0	Q3
LM3880MFX-1AA/NOPB	SOT-23	DBV	6	3000	178.0	8.4	3.2	3.2	1.4	4.0	8.0	Q3
LM3880MFX-1AB/NOPB	SOT-23	DBV	6	3000	178.0	8.4	3.2	3.2	1.4	4.0	8.0	Q3
LM3880MFX-1AC/NOPB	SOT-23	DBV	6	3000	178.0	8.4	3.2	3.2	1.4	4.0	8.0	Q3
LM3880MFX-1AD/NOPB	SOT-23	DBV	6	3000	178.0	8.4	3.2	3.2	1.4	4.0	8.0	Q3
LM3880MFX-1AE/NOPB	SOT-23	DBV	6	3000	178.0	8.4	3.2	3.2	1.4	4.0	8.0	Q3

Device	Package Type	Package Drawing	Pins	SPQ	Reel Diameter (mm)	Reel Width W1 (mm)	A0 (mm)	B0 (mm)	K0 (mm)	P1 (mm)	W (mm)	Pin1 Quadrant
LM3880MFX-1AF/NOPB	SOT-23	DBV	6	3000	178.0	8.4	3.2	3.2	1.4	4.0	8.0	Q3
LM3880QMF-1AA/NOPB	SOT-23	DBV	6	1000	178.0	8.4	3.2	3.2	1.4	4.0	8.0	Q3
LM3880QMF-1AB/NOPB	SOT-23	DBV	6	1000	178.0	8.4	3.2	3.2	1.4	4.0	8.0	Q3
LM3880QMF-1AC/NOPB	SOT-23	DBV	6	1000	178.0	8.4	3.2	3.2	1.4	4.0	8.0	Q3
LM3880QMF-1AD/NOPB	SOT-23	DBV	6	1000	178.0	8.4	3.2	3.2	1.4	4.0	8.0	Q3
LM3880QMF-1AE/NOPB	SOT-23	DBV	6	1000	178.0	8.4	3.2	3.2	1.4	4.0	8.0	Q3
LM3880QMF-1AF/NOPB	SOT-23	DBV	6	1000	178.0	8.4	3.2	3.2	1.4	4.0	8.0	Q3
LM3880QMFE-1AA/NOPB	SOT-23	DBV	6	250	178.0	8.4	3.2	3.2	1.4	4.0	8.0	Q3
LM3880QMFE-1AB/NOPB	SOT-23	DBV	6	250	178.0	8.4	3.2	3.2	1.4	4.0	8.0	Q3
LM3880QMFE-1AC/NOPB	SOT-23	DBV	6	250	178.0	8.4	3.2	3.2	1.4	4.0	8.0	Q3
LM3880QMFE-1AD/NOPB	SOT-23	DBV	6	250	178.0	8.4	3.2	3.2	1.4	4.0	8.0	Q3
LM3880QMFE-1AE/NOPB	SOT-23	DBV	6	250	178.0	8.4	3.2	3.2	1.4	4.0	8.0	Q3
LM3880QMFE-1AF/NOPB	SOT-23	DBV	6	250	178.0	8.4	3.2	3.2	1.4	4.0	8.0	Q3
LM3880QMF-1AA/NOPB	SOT-23	DBV	6	3000	178.0	8.4	3.2	3.2	1.4	4.0	8.0	Q3
LM3880QMF-1AB/NOPB	SOT-23	DBV	6	3000	178.0	8.4	3.2	3.2	1.4	4.0	8.0	Q3
LM3880QMF-1AC/NOPB	SOT-23	DBV	6	3000	178.0	8.4	3.2	3.2	1.4	4.0	8.0	Q3
LM3880QMF-1AD/NOPB	SOT-23	DBV	6	3000	178.0	8.4	3.2	3.2	1.4	4.0	8.0	Q3
LM3880QMF-1AE/NOPB	SOT-23	DBV	6	3000	178.0	8.4	3.2	3.2	1.4	4.0	8.0	Q3
LM3880QMF-1AF/NOPB	SOT-23	DBV	6	3000	178.0	8.4	3.2	3.2	1.4	4.0	8.0	Q3

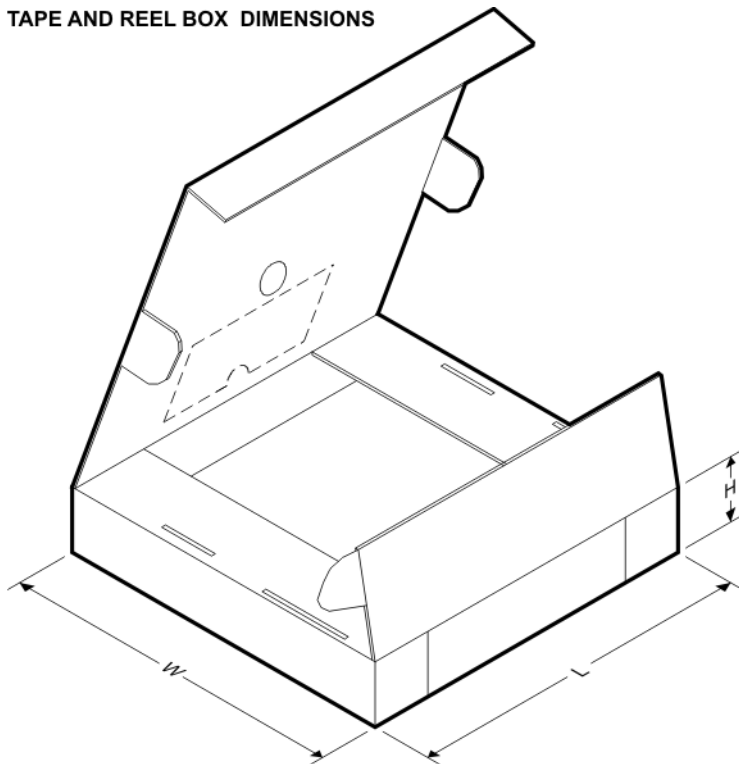
TAPE AND REEL BOX DIMENSIONS

*All dimensions are nominal

Device	Package Type	Package Drawing	Pins	SPQ	Length (mm)	Width (mm)	Height (mm)
LM3880MF-1AA	SOT-23	DBV	6	1000	210.0	185.0	35.0
LM3880MF-1AA/NOPB	SOT-23	DBV	6	1000	210.0	185.0	35.0
LM3880MF-1AB/NOPB	SOT-23	DBV	6	1000	210.0	185.0	35.0
LM3880MF-1AC/NOPB	SOT-23	DBV	6	1000	210.0	185.0	35.0
LM3880MF-1AD/NOPB	SOT-23	DBV	6	1000	210.0	185.0	35.0
LM3880MF-1AE/NOPB	SOT-23	DBV	6	1000	210.0	185.0	35.0
LM3880MF-1AF/NOPB	SOT-23	DBV	6	1000	210.0	185.0	35.0
LM3880MFE-1AA/NOPB	SOT-23	DBV	6	250	210.0	185.0	35.0
LM3880MFE-1AB/NOPB	SOT-23	DBV	6	250	210.0	185.0	35.0
LM3880MFE-1AC/NOPB	SOT-23	DBV	6	250	210.0	185.0	35.0
LM3880MFE-1AD/NOPB	SOT-23	DBV	6	250	210.0	185.0	35.0
LM3880MFE-1AE/NOPB	SOT-23	DBV	6	250	210.0	185.0	35.0
LM3880MFE-1AF/NOPB	SOT-23	DBV	6	250	210.0	185.0	35.0
LM3880MFX-1AA/NOPB	SOT-23	DBV	6	3000	210.0	185.0	35.0
LM3880MFX-1AB/NOPB	SOT-23	DBV	6	3000	210.0	185.0	35.0
LM3880MFX-1AC/NOPB	SOT-23	DBV	6	3000	210.0	185.0	35.0
LM3880MFX-1AD/NOPB	SOT-23	DBV	6	3000	210.0	185.0	35.0
LM3880MFX-1AE/NOPB	SOT-23	DBV	6	3000	210.0	185.0	35.0
LM3880MFX-1AF/NOPB	SOT-23	DBV	6	3000	210.0	185.0	35.0
LM3880QMF-1AA/NOPB	SOT-23	DBV	6	1000	210.0	185.0	35.0
LM3880QMF-1AB/NOPB	SOT-23	DBV	6	1000	210.0	185.0	35.0
LM3880QMF-1AC/NOPB	SOT-23	DBV	6	1000	210.0	185.0	35.0
LM3880QMF-1AD/NOPB	SOT-23	DBV	6	1000	210.0	185.0	35.0
LM3880QMF-1AE/NOPB	SOT-23	DBV	6	1000	210.0	185.0	35.0
LM3880QMF-1AF/NOPB	SOT-23	DBV	6	1000	210.0	185.0	35.0
LM3880QMFE-1AA/NOPB	SOT-23	DBV	6	250	210.0	185.0	35.0
LM3880QMFE-1AB/NOPB	SOT-23	DBV	6	250	210.0	185.0	35.0
LM3880QMFE-1AC/NOPB	SOT-23	DBV	6	250	210.0	185.0	35.0
LM3880QMFE-1AD/NOPB	SOT-23	DBV	6	250	210.0	185.0	35.0
LM3880QMFE-1AE/NOPB	SOT-23	DBV	6	250	210.0	185.0	35.0
LM3880QMFE-1AF/NOPB	SOT-23	DBV	6	250	210.0	185.0	35.0
LM3880QMFX-1AA/NOPB	SOT-23	DBV	6	3000	210.0	185.0	35.0
LM3880QMFX-1AB/NOPB	SOT-23	DBV	6	3000	210.0	185.0	35.0
LM3880QMFX-1AC/NOPB	SOT-23	DBV	6	3000	210.0	185.0	35.0
LM3880QMFX-1AD/NOPB	SOT-23	DBV	6	3000	210.0	185.0	35.0
LM3880QMFX-1AE/NOPB	SOT-23	DBV	6	3000	210.0	185.0	35.0
LM3880QMFX-1AF/NOPB	SOT-23	DBV	6	3000	210.0	185.0	35.0

MECHANICAL DATA

DBV (R-PDSO-G6)

PLASTIC SMALL-OUTLINE PACKAGE

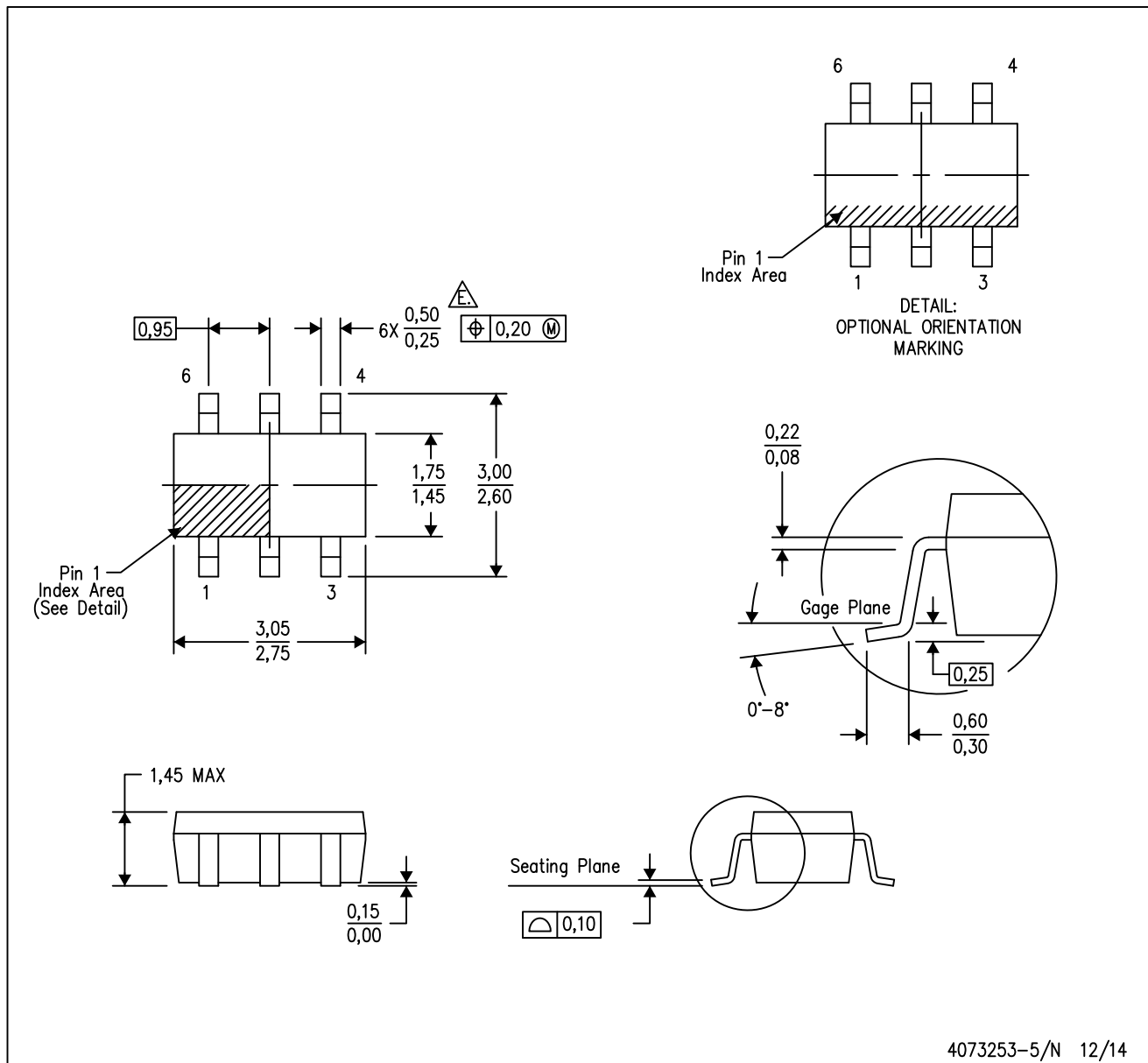

- NOTES:
- A. All linear dimensions are in millimeters.
 - B. This drawing is subject to change without notice.
 - C. Body dimensions do not include mold flash or protrusion. Mold flash and protrusion shall not exceed 0.15 per side.
 - D. Leads 1,2,3 may be wider than leads 4,5,6 for package orientation.
- ⚠ Falls within JEDEC MO-178 Variation AB, except minimum lead width.

IMPORTANT NOTICE

Texas Instruments Incorporated and its subsidiaries (TI) reserve the right to make corrections, enhancements, improvements and other changes to its semiconductor products and services per JESD46, latest issue, and to discontinue any product or service per JESD48, latest issue. Buyers should obtain the latest relevant information before placing orders and should verify that such information is current and complete. All semiconductor products (also referred to herein as "components") are sold subject to TI's terms and conditions of sale supplied at the time of order acknowledgment.

TI warrants performance of its components to the specifications applicable at the time of sale, in accordance with the warranty in TI's terms and conditions of sale of semiconductor products. Testing and other quality control techniques are used to the extent TI deems necessary to support this warranty. Except where mandated by applicable law, testing of all parameters of each component is not necessarily performed.

TI assumes no liability for applications assistance or the design of Buyers' products. Buyers are responsible for their products and applications using TI components. To minimize the risks associated with Buyers' products and applications, Buyers should provide adequate design and operating safeguards.

TI does not warrant or represent that any license, either express or implied, is granted under any patent right, copyright, mask work right, or other intellectual property right relating to any combination, machine, or process in which TI components or services are used. Information published by TI regarding third-party products or services does not constitute a license to use such products or services or a warranty or endorsement thereof. Use of such information may require a license from a third party under the patents or other intellectual property of the third party, or a license from TI under the patents or other intellectual property of TI.

Reproduction of significant portions of TI information in TI data books or data sheets is permissible only if reproduction is without alteration and is accompanied by all associated warranties, conditions, limitations, and notices. TI is not responsible or liable for such altered documentation. Information of third parties may be subject to additional restrictions.

Resale of TI components or services with statements different from or beyond the parameters stated by TI for that component or service voids all express and any implied warranties for the associated TI component or service and is an unfair and deceptive business practice. TI is not responsible or liable for any such statements.

Buyer acknowledges and agrees that it is solely responsible for compliance with all legal, regulatory and safety-related requirements concerning its products, and any use of TI components in its applications, notwithstanding any applications-related information or support that may be provided by TI. Buyer represents and agrees that it has all the necessary expertise to create and implement safeguards which anticipate dangerous consequences of failures, monitor failures and their consequences, lessen the likelihood of failures that might cause harm and take appropriate remedial actions. Buyer will fully indemnify TI and its representatives against any damages arising out of the use of any TI components in safety-critical applications.

In some cases, TI components may be promoted specifically to facilitate safety-related applications. With such components, TI's goal is to help enable customers to design and create their own end-product solutions that meet applicable functional safety standards and requirements. Nonetheless, such components are subject to these terms.

No TI components are authorized for use in FDA Class III (or similar life-critical medical equipment) unless authorized officers of the parties have executed a special agreement specifically governing such use.

Only those TI components which TI has specifically designated as military grade or "enhanced plastic" are designed and intended for use in military/aerospace applications or environments. Buyer acknowledges and agrees that any military or aerospace use of TI components which have **not** been so designated is solely at the Buyer's risk, and that Buyer is solely responsible for compliance with all legal and regulatory requirements in connection with such use.

TI has specifically designated certain components as meeting ISO/TS16949 requirements, mainly for automotive use. In any case of use of non-designated products, TI will not be responsible for any failure to meet ISO/TS16949.

Products

Audio	www.ti.com/audio
Amplifiers	amplifier.ti.com
Data Converters	dataconverter.ti.com
DLP® Products	www.dlp.com
DSP	dsp.ti.com
Clocks and Timers	www.ti.com/clocks
Interface	interface.ti.com
Logic	logic.ti.com
Power Mgmt	power.ti.com
Microcontrollers	microcontroller.ti.com
RFID	www.ti-rfid.com
OMAP Applications Processors	www.ti.com/omap
Wireless Connectivity	www.ti.com/wirelessconnectivity

Applications

Automotive and Transportation	www.ti.com/automotive
Communications and Telecom	www.ti.com/communications
Computers and Peripherals	www.ti.com/computers
Consumer Electronics	www.ti.com/consumer-apps
Energy and Lighting	www.ti.com/energy
Industrial	www.ti.com/industrial
Medical	www.ti.com/medical
Security	www.ti.com/security
Space, Avionics and Defense	www.ti.com/space-avionics-defense
Video and Imaging	www.ti.com/video

TI E2E Community

e2e.ti.com