

LM8364 Micropower Undervoltage Sensing Circuits

Check for Samples: [LM8364](#)

FEATURES

- **Extremely Low Quiescent Current: 0.65 μ A, at $V_{IN} = 2.87V$**
- **High Accuracy Threshold Voltage ($\pm 2.5\%$)**
- **Open Drain Output**
- **Input Voltage Range: 1V to 6V**
- **Surface Mount Package (5-Pin SOT-23)**
- **Pin for Pin Compatible with MC33464**

APPLICATIONS

- **Low Battery Detection**
- **Microprocessor Reset Controller**
- **Power Fail Indicator**
- **Battery Backup Detection**

DESCRIPTION

The LM8364 series are micropower undervoltage sensing circuits that are ideal for use in battery powered microprocessor based systems, where extended battery life is a key requirement.

A range of threshold voltages from 2.0V to 4.5V are available with an active low open drain output. These devices feature a very low quiescent current of 0.65 μ A typical. The LM8364 series features a highly accurate voltage reference, a comparator with precise thresholds and built-in hysteresis to prevent erratic reset operation, and ensured Reset operation down to 1.0V with extremely low standby current.

These devices are available in the space saving SOT-23 5-pin surface mount package. For other undervoltage thresholds and output options, please contact Texas Instruments.

Functional Block Diagram

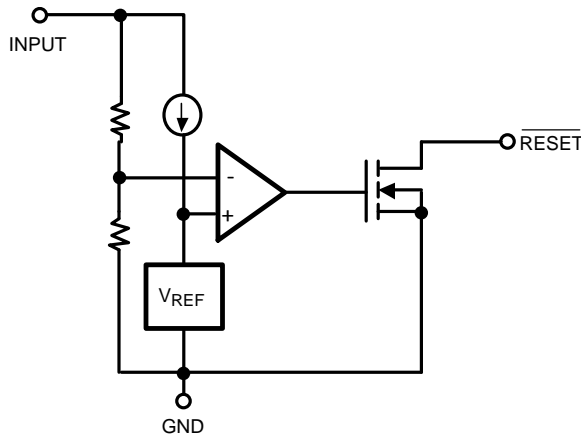

Connection Diagram

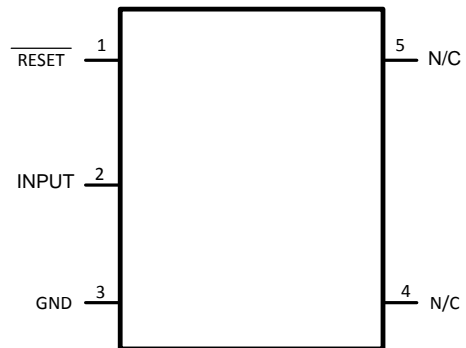

**Figure 1. 5-Pin SOT-23
Top View**



Please be aware that an important notice concerning availability, standard warranty, and use in critical applications of Texas Instruments semiconductor products and disclaimers thereto appears at the end of this data sheet.

All trademarks are the property of their respective owners.



These devices have limited built-in ESD protection. The leads should be shorted together or the device placed in conductive foam during storage or handling to prevent electrostatic damage to the MOS gates.

Absolute Maximum Ratings⁽¹⁾⁽²⁾

Supply Voltage	-0.3V to 6.5V	
$\overline{\text{RESET}}$ Output Voltage	-0.3V to 6.5V	
$\overline{\text{RESET}}$ Output Current	70mA	
Storage Temperature Range	-65°C to 150°C	
Mounting Temp.	Lead Temp (Soldering, 10 sec)	260°C
Junction Temperature	125°	

- (1) Absolute Maximum Ratings indicate limits beyond which damage to the device may occur. Operating Ratings indicate conditions for which the device is intended to be functional, but specific performance is not ensured. For ensured specifications and the test conditions, see the Electrical Characteristics.
- (2) If Military/Aerospace specified devices are required, please contact the Texas Instruments Sales Office/Distributors for availability and specifications.

Operating Ratings⁽¹⁾

Temperature Range	-40°C to 85°C
Thermal Resistance to ambient (θ_{JA})	265°C/W
ESD Tolerance	
Human Body Model	2000V
Machine Model	200V

- (1) Absolute Maximum Ratings indicate limits beyond which damage to the device may occur. Operating Ratings indicate conditions for which the device is intended to be functional, but specific performance is not ensured. For ensured specifications and the test conditions, see the Electrical Characteristics.

Electrical Characteristics

Unless otherwise specified, all limits ensured for $T_A = 25^\circ\text{C}$.

Symbol	Parameter	Conditions	Min ⁽¹⁾	Typ ⁽²⁾	Max ⁽¹⁾	Units
$V_{\text{DET-}}$	Detector Threshold Voltage	High to Low State Output (V_{IN} Decreasing)				V
		20 Suffix	1.950	2.0	2.050	
		27 Suffix	2.633	2.7	2.767	
		30 Suffix	2.925	3.0	3.075	
		32 Suffix	3.120	3.2	3.280	
V_{HYS}	Detector Threshold Hysteresis	V_{IN} Increasing				V
		20 Suffix	0.060	0.100	0.140	
		27 Suffix	0.081	0.135	0.189	
		30 Suffix	0.090	0.150	0.210	
		32 Suffix	0.096	0.160	0.224	
45 Suffix	0.135	0.225	0.315			
$\Delta V_{\text{det}}/\Delta T$	Detector Threshold Voltage Temperature Coefficient			± 100		PPM/°C
V_{OL}	$\overline{\text{RESET}}$ Output Voltage Low State	(Open Drain Output: $I_{\text{SINK}} = 1\text{mA}$)		0.25	0.5	V
I_{OL}	$\overline{\text{RESET}}$ Output Sink Current	$V_{\text{IN}} = 1.5\text{V}$, $V_{\text{OL}} = 0.5\text{V}$	1.0	2.5		mA
V_{IN}	Operating Input Voltage Range		1.0		6.0	V

- (1) All limits are ensured by testing or statistical analysis.
- (2) Typical values represent the most likely parametric norm

Electrical Characteristics (continued)

 Unless otherwise specified, all limits ensured for $T_A = 25^\circ\text{C}$.

Symbol	Parameter	Conditions	Min (1)	Typ (2)	Max (1)	Units
I_{IN}	Quiescent Input Current	20 Suffix				μA
		$V_{IN} = 1.9\text{V}$		0.55	0.8	
		$V_{IN} = 4.0\text{V}$		0.70	1.3	
		27 Suffix				
		$V_{IN} = 2.6\text{V}$		0.62	0.9	
		$V_{IN} = 4.7\text{V}$		0.75	1.3	
		30 Suffix				
		$V_{IN} = 2.87\text{V}$		0.65	0.9	
		$V_{IN} = 5.0\text{V}$		0.77	1.3	
		32 Suffix				
		$V_{IN} = 3.08\text{V}$		0.66	0.9	
		$V_{IN} = 5.20\text{V}$		0.79	1.3	
		45 Suffix				
		$V_{IN} = 4.34\text{V}$		0.70	1.0	
$V_{IN} = 6.0$		0.85	1.4			
t_p	Propagation Delay Time Figure 7			60	300	μs

Typical Performance Characteristics

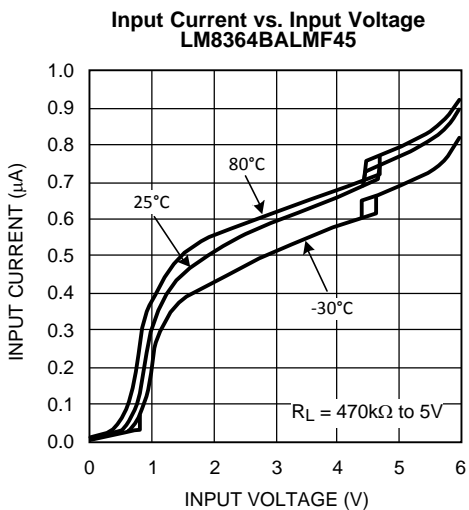

Figure 2.

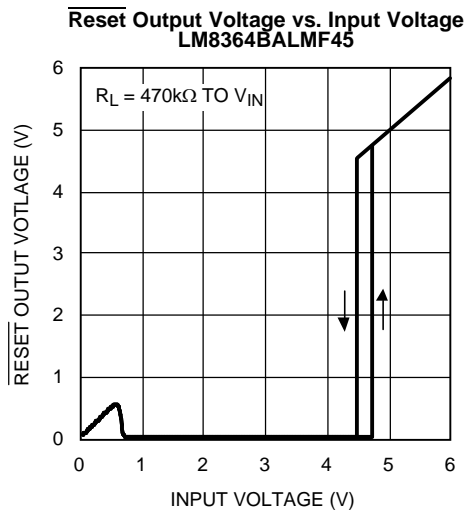

Figure 3.

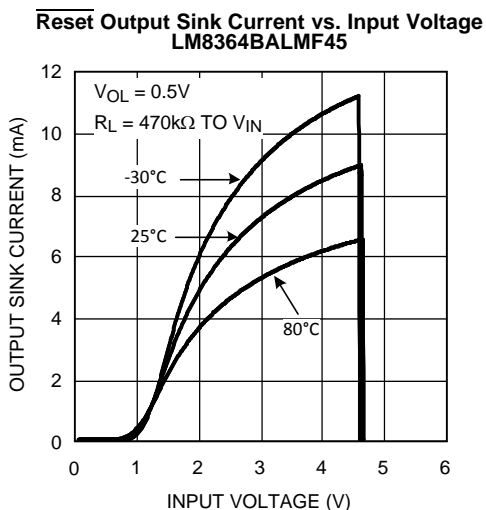

Figure 4.

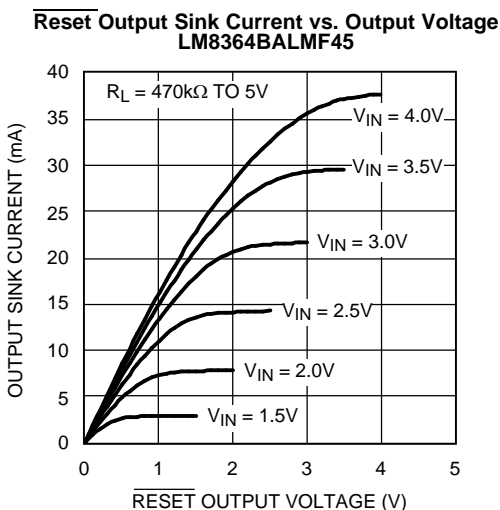

Figure 5.

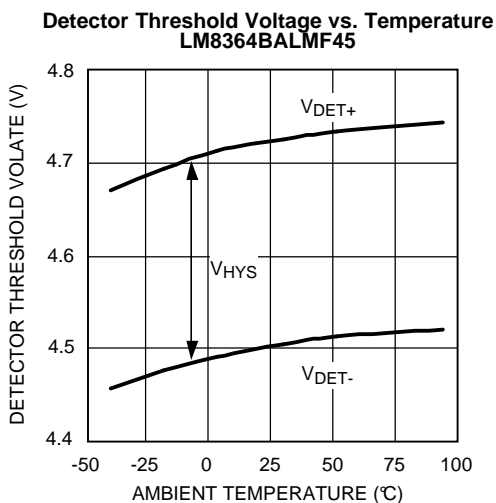

Figure 6.

APPLICATION NOTES

The propagation delay time for the LM8364 is measured using a 470kΩ pull-up resistor connected to from the RESET output pin to 5V in addition to a 10pF capacitive load connected from the same pin to GND. Figure 7 shows the timing diagram for the measurement of the propagation delay. V_{DET+} is equal to the sum of the detector threshold, V_{DET-} , and the built in hysteresis, V_{HYS} .

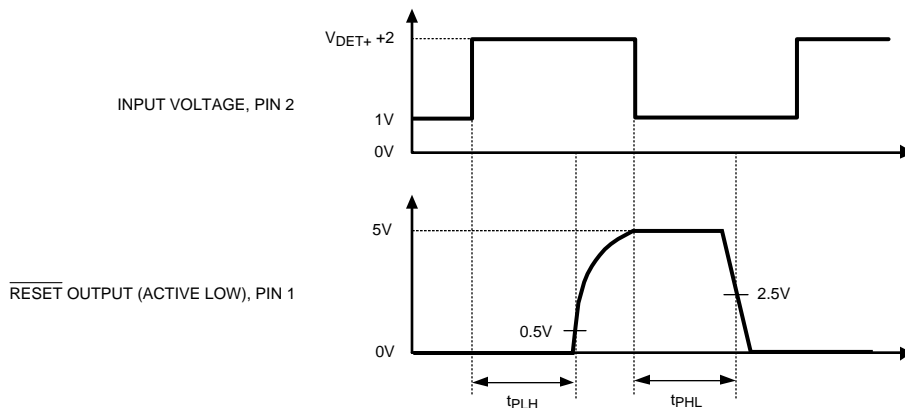

Figure 7. Propagation Delay Timing Diagrams

The LM8364 ultra-low current voltage detector was designed to monitor voltages and to provide an indication when the monitored voltage, V_{IN} , dropped below a precisely trimmed threshold voltage. This characteristic is displayed in the typical operating timing diagram below. V_{IN} is the voltage that is being monitored and a pull up resistor is connected from the RESET output pin to V_{IN} . V_{IN} is at some value above V_{DET+} and then begins to decrease. Since this is an Active Low device the RESET output is pulled High through the pull-up resistor and tracks V_{IN} until V_{IN} crosses the trimmed threshold V_{DET-} . At this point the LM8364 recognizes that V_{IN} is now in a fault condition and the output immediately changes to the Logic Low State. The RESET output will remain in this low state until V_{IN} increases above the threshold $V_{DET-} + V_{HYS}$. This point is also known as V_{DET+} as indicated earlier. This built-in hysteresis has been added to the design to help prevent erratic reset operation when the input voltage crosses the threshold.

The LM8364 has a wide variety of applications that can take advantage of its precision and low current consumption to monitor Input voltages even though it was designed as a reset controller in portable microprocessor based systems. It is a very cost effective and space saving device that will protect your more expensive investments of microprocessors and other devices that need a specified supply voltage for proper operation.

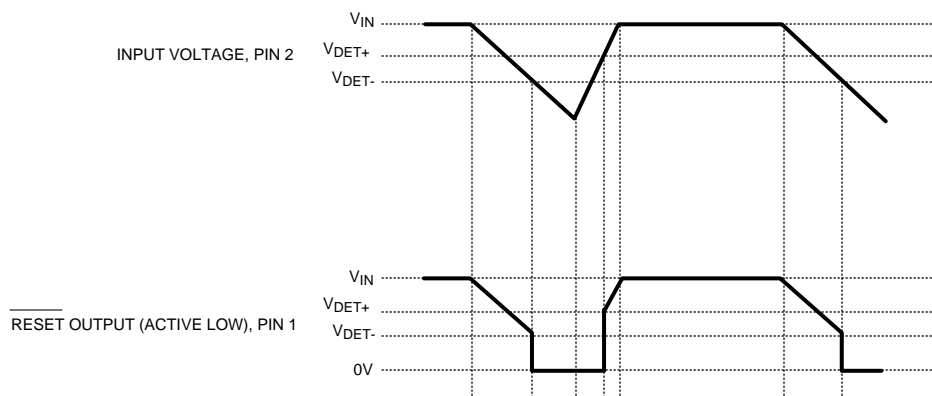

Figure 8. Timing Waveforms

Typical Applications

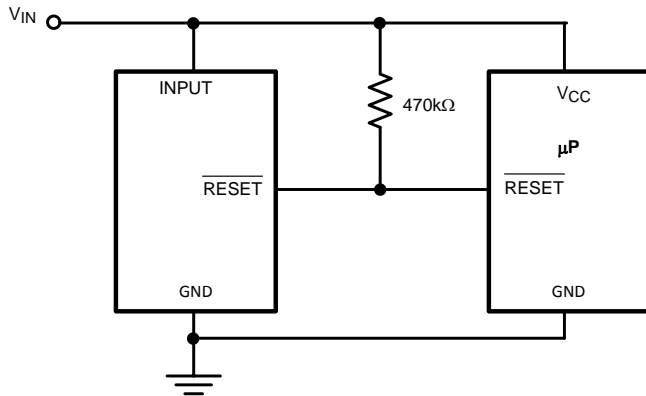

Figure 9. Microprocessor Reset Circuit

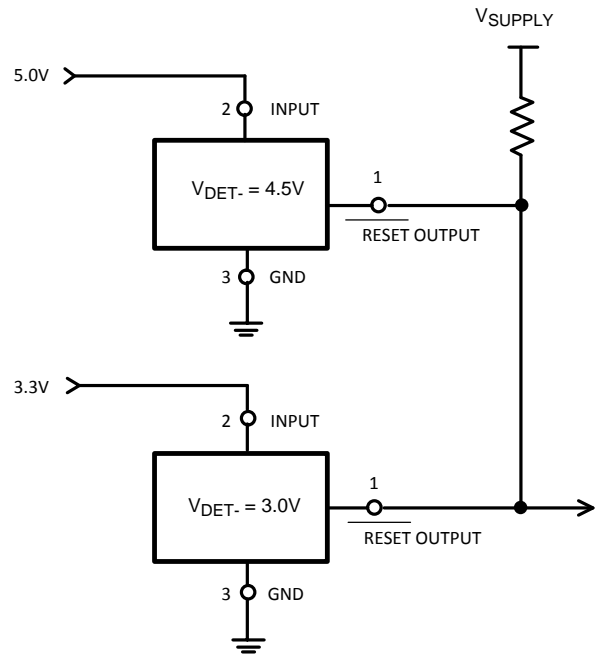
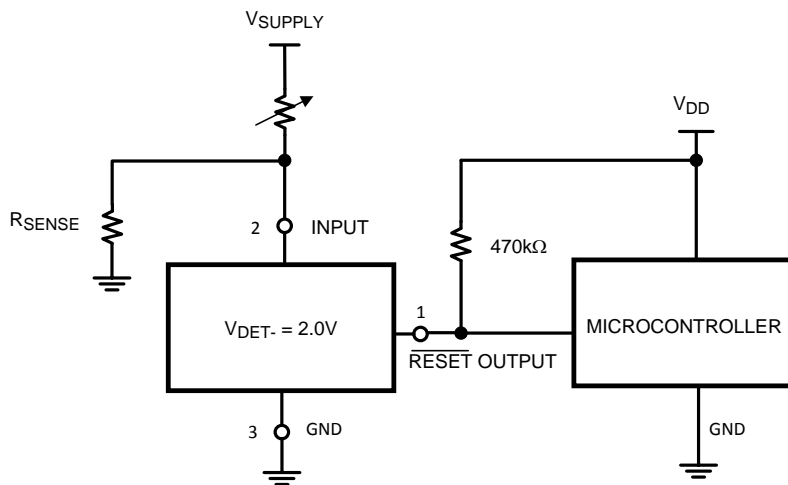

Figure 10. Dual Power Supply Undervoltage Supervision



THIS CIRCUIT MONITORS THE CURRENT AT THE LOAD. AS CURRENT FLOW THROUGH THE LOAD, A VOLTAGE DROP WITH RESPECT TO GROUND APPEARS ACROSS R_{SENSE} WHERE $V_{SENSE} = I_{LOAD} * R_{SENSE}$. THE FOLLOWING CONDITIONS APPLY:

IF:	THEN:
$I_{LOAD} < V_{DET-} / R_{SENSE}$	$\overline{RESET} \text{ OUTPUT} = 0V$
$I_{LOAD} \geq (V_{DET-} + V_{HYS}) / R_{SENSE}$	$\overline{RESET} \text{ OUTPUT} = V_{DD}$

Figure 11. Microcontroller System Load Sensing

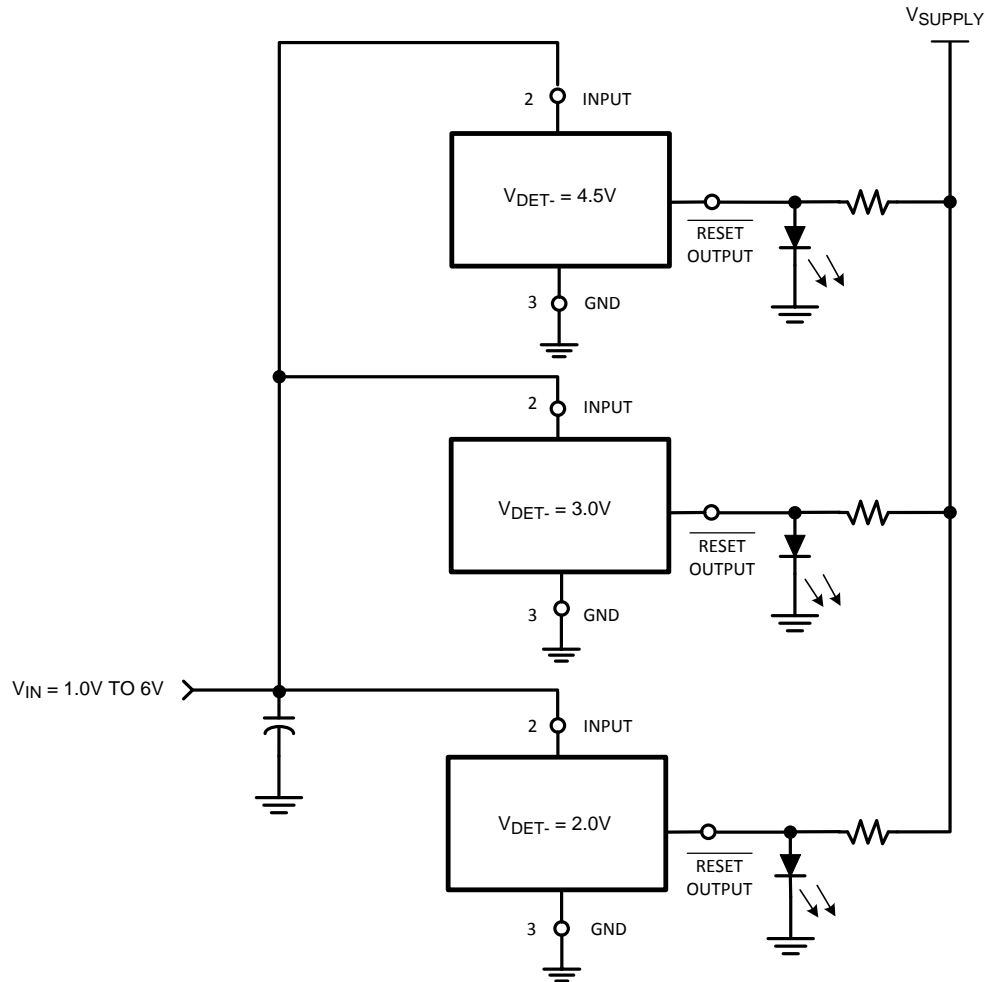

EACH LED WILL SEQUENTIALLY TURN ON WHEN THE RESPECTIVE VOLTAGE DETECTOR THRESHOLD ($V_{DET-} + V_{HYS}$) IS EXCEEDED.

Figure 12. LED Bar Graph Voltage Monitor

REVISION HISTORY

Changes from Revision A (April 2013) to Revision B	Page
• Changed layout of National Data Sheet to TI format	7

PACKAGING INFORMATION

Orderable Device	Status (1)	Package Type	Package Drawing	Pins	Package Qty	Eco Plan (2)	Lead/Ball Finish (6)	MSL Peak Temp (3)	Op Temp (°C)	Device Marking (4/5)	Samples
LM8364BALMF20	NRND	SOT-23	DBV	5	1000	TBD	Call TI	Call TI	-40 to 85	F01A	
LM8364BALMF20/NOPB	ACTIVE	SOT-23	DBV	5	1000	Green (RoHS & no Sb/Br)	CU SN	Level-1-260C-UNLIM	-40 to 85	F01A	Samples
LM8364BALMF20/NOPB	ACTIVE	SOT-23	DBV	5	3000	Green (RoHS & no Sb/Br)	CU SN	Level-1-260C-UNLIM	-40 to 85	F01A	Samples

(1) The marketing status values are defined as follows:

ACTIVE: Product device recommended for new designs.

LIFEBUY: TI has announced that the device will be discontinued, and a lifetime-buy period is in effect.

NRND: Not recommended for new designs. Device is in production to support existing customers, but TI does not recommend using this part in a new design.

PREVIEW: Device has been announced but is not in production. Samples may or may not be available.

OBSOLETE: TI has discontinued the production of the device.

(2) Eco Plan - The planned eco-friendly classification: Pb-Free (RoHS), Pb-Free (RoHS Exempt), or Green (RoHS & no Sb/Br) - please check <http://www.ti.com/productcontent> for the latest availability information and additional product content details.

TBD: The Pb-Free/Green conversion plan has not been defined.

Pb-Free (RoHS): TI's terms "Lead-Free" or "Pb-Free" mean semiconductor products that are compatible with the current RoHS requirements for all 6 substances, including the requirement that lead not exceed 0.1% by weight in homogeneous materials. Where designed to be soldered at high temperatures, TI Pb-Free products are suitable for use in specified lead-free processes.

Pb-Free (RoHS Exempt): This component has a RoHS exemption for either 1) lead-based flip-chip solder bumps used between the die and package, or 2) lead-based die adhesive used between the die and leadframe. The component is otherwise considered Pb-Free (RoHS compatible) as defined above.

Green (RoHS & no Sb/Br): TI defines "Green" to mean Pb-Free (RoHS compatible), and free of Bromine (Br) and Antimony (Sb) based flame retardants (Br or Sb do not exceed 0.1% by weight in homogeneous material)

(3) MSL, Peak Temp. - The Moisture Sensitivity Level rating according to the JEDEC industry standard classifications, and peak solder temperature.

(4) There may be additional marking, which relates to the logo, the lot trace code information, or the environmental category on the device.

(5) Multiple Device Markings will be inside parentheses. Only one Device Marking contained in parentheses and separated by a "~" will appear on a device. If a line is indented then it is a continuation of the previous line and the two combined represent the entire Device Marking for that device.

(6) Lead/Ball Finish - Orderable Devices may have multiple material finish options. Finish options are separated by a vertical ruled line. Lead/Ball Finish values may wrap to two lines if the finish value exceeds the maximum column width.

Important Information and Disclaimer: The information provided on this page represents TI's knowledge and belief as of the date that it is provided. TI bases its knowledge and belief on information provided by third parties, and makes no representation or warranty as to the accuracy of such information. Efforts are underway to better integrate information from third parties. TI has taken and

continues to take reasonable steps to provide representative and accurate information but may not have conducted destructive testing or chemical analysis on incoming materials and chemicals. TI and TI suppliers consider certain information to be proprietary, and thus CAS numbers and other limited information may not be available for release.

In no event shall TI's liability arising out of such information exceed the total purchase price of the TI part(s) at issue in this document sold by TI to Customer on an annual basis.

TAPE AND REEL INFORMATION



QUADRANT ASSIGNMENTS FOR PIN 1 ORIENTATION IN TAPE



*All dimensions are nominal

Device	Package Type	Package Drawing	Pins	SPQ	Reel Diameter (mm)	Reel Width W1 (mm)	A0 (mm)	B0 (mm)	K0 (mm)	P1 (mm)	W (mm)	Pin1 Quadrant
LM8364BALMF20	SOT-23	DBV	5	1000	178.0	8.4	3.2	3.2	1.4	4.0	8.0	Q3
LM8364BALMF20/NOPB	SOT-23	DBV	5	1000	178.0	8.4	3.2	3.2	1.4	4.0	8.0	Q3
LM8364BALMFX20/NOPB	SOT-23	DBV	5	3000	178.0	8.4	3.2	3.2	1.4	4.0	8.0	Q3

TAPE AND REEL BOX DIMENSIONS



*All dimensions are nominal

Device	Package Type	Package Drawing	Pins	SPQ	Length (mm)	Width (mm)	Height (mm)
LM8364BALMF20	SOT-23	DBV	5	1000	210.0	185.0	35.0
LM8364BALMF20/NOPB	SOT-23	DBV	5	1000	210.0	185.0	35.0
LM8364BALMFX20/NOPB	SOT-23	DBV	5	3000	210.0	185.0	35.0

DBV (R-PDSO-G5)

PLASTIC SMALL-OUTLINE PACKAGE

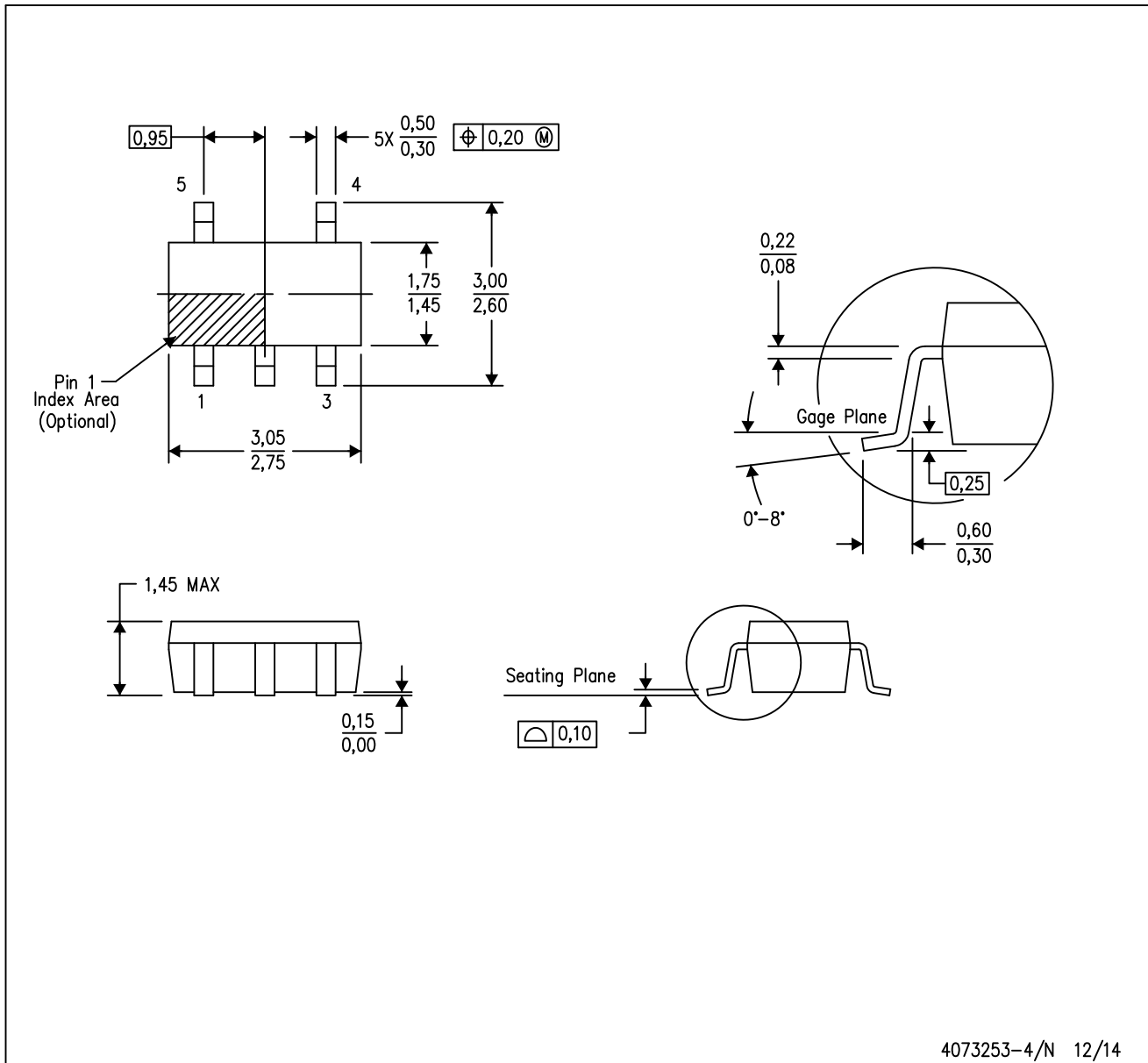

- NOTES:
- All linear dimensions are in millimeters.
 - This drawing is subject to change without notice.
 - Body dimensions do not include mold flash or protrusion. Mold flash and protrusion shall not exceed 0.15 per side.
 - Falls within JEDEC MO-178 Variation AA.

IMPORTANT NOTICE

Texas Instruments Incorporated and its subsidiaries (TI) reserve the right to make corrections, enhancements, improvements and other changes to its semiconductor products and services per JESD46, latest issue, and to discontinue any product or service per JESD48, latest issue. Buyers should obtain the latest relevant information before placing orders and should verify that such information is current and complete. All semiconductor products (also referred to herein as "components") are sold subject to TI's terms and conditions of sale supplied at the time of order acknowledgment.

TI warrants performance of its components to the specifications applicable at the time of sale, in accordance with the warranty in TI's terms and conditions of sale of semiconductor products. Testing and other quality control techniques are used to the extent TI deems necessary to support this warranty. Except where mandated by applicable law, testing of all parameters of each component is not necessarily performed.

TI assumes no liability for applications assistance or the design of Buyers' products. Buyers are responsible for their products and applications using TI components. To minimize the risks associated with Buyers' products and applications, Buyers should provide adequate design and operating safeguards.

TI does not warrant or represent that any license, either express or implied, is granted under any patent right, copyright, mask work right, or other intellectual property right relating to any combination, machine, or process in which TI components or services are used. Information published by TI regarding third-party products or services does not constitute a license to use such products or services or a warranty or endorsement thereof. Use of such information may require a license from a third party under the patents or other intellectual property of the third party, or a license from TI under the patents or other intellectual property of TI.

Reproduction of significant portions of TI information in TI data books or data sheets is permissible only if reproduction is without alteration and is accompanied by all associated warranties, conditions, limitations, and notices. TI is not responsible or liable for such altered documentation. Information of third parties may be subject to additional restrictions.

Resale of TI components or services with statements different from or beyond the parameters stated by TI for that component or service voids all express and any implied warranties for the associated TI component or service and is an unfair and deceptive business practice. TI is not responsible or liable for any such statements.

Buyer acknowledges and agrees that it is solely responsible for compliance with all legal, regulatory and safety-related requirements concerning its products, and any use of TI components in its applications, notwithstanding any applications-related information or support that may be provided by TI. Buyer represents and agrees that it has all the necessary expertise to create and implement safeguards which anticipate dangerous consequences of failures, monitor failures and their consequences, lessen the likelihood of failures that might cause harm and take appropriate remedial actions. Buyer will fully indemnify TI and its representatives against any damages arising out of the use of any TI components in safety-critical applications.

In some cases, TI components may be promoted specifically to facilitate safety-related applications. With such components, TI's goal is to help enable customers to design and create their own end-product solutions that meet applicable functional safety standards and requirements. Nonetheless, such components are subject to these terms.

No TI components are authorized for use in FDA Class III (or similar life-critical medical equipment) unless authorized officers of the parties have executed a special agreement specifically governing such use.

Only those TI components which TI has specifically designated as military grade or "enhanced plastic" are designed and intended for use in military/aerospace applications or environments. Buyer acknowledges and agrees that any military or aerospace use of TI components which have **not** been so designated is solely at the Buyer's risk, and that Buyer is solely responsible for compliance with all legal and regulatory requirements in connection with such use.

TI has specifically designated certain components as meeting ISO/TS16949 requirements, mainly for automotive use. In any case of use of non-designated products, TI will not be responsible for any failure to meet ISO/TS16949.

Products

Audio	www.ti.com/audio
Amplifiers	amplifier.ti.com
Data Converters	dataconverter.ti.com
DLP® Products	www.dlp.com
DSP	dsp.ti.com
Clocks and Timers	www.ti.com/clocks
Interface	interface.ti.com
Logic	logic.ti.com
Power Mgmt	power.ti.com
Microcontrollers	microcontroller.ti.com
RFID	www.ti-rfid.com
OMAP Applications Processors	www.ti.com/omap
Wireless Connectivity	www.ti.com/wirelessconnectivity

Applications

Automotive and Transportation	www.ti.com/automotive
Communications and Telecom	www.ti.com/communications
Computers and Peripherals	www.ti.com/computers
Consumer Electronics	www.ti.com/consumer-apps
Energy and Lighting	www.ti.com/energy
Industrial	www.ti.com/industrial
Medical	www.ti.com/medical
Security	www.ti.com/security
Space, Avionics and Defense	www.ti.com/space-avionics-defense
Video and Imaging	www.ti.com/video

TI E2E Community

e2e.ti.com