

LMH0002 SMPTE 292M / 259M Serial Digital Cable Driver

Check for Samples: [LMH0002](#)

FEATURES

- SMPTE 292M, SMPTE 344M and SMPTE 259M Compliant
- Supports DVB-ASI at 270 Mbps
- Data Rates to 1.485 Gbps
- Differential Input
- 75Ω Differential Output
- Selectable Slew Rate
- Adjustable Output Amplitude
- Single 3.3V Supply Operation
- Operating Temperature Range: Commercial 0°C to +70°C (LMH0002MA) or Industrial –40°C to +85°C (LMH0002TMA and LMH0002SQ)
- Typical Power Consumption: 125 mW in SD Mode and 149 mW in HD Mode
- 8-pin SOIC or 16-pin WQFN Package
- Replaces the GS1528, GS1528A, or GS1578A

APPLICATIONS

- SMPTE 292M, SMPTE 344M, and SMPTE 259M Serial Digital Interfaces
- Sonet/SDH and ATM Interfaces
- Digital Routers and Switches
- Distribution Amplifiers
- Buffer Applications
- Set Top Boxes
- Security Cameras

DESCRIPTION

The LMH0002 SMPTE 292M / 259M serial digital cable driver is a monolithic, high-speed cable driver designed for use in SMPTE 292M / 259M serial digital video and ITU-T G.703 serial digital data transmission applications. The LMH0002 drives 75Ω transmission lines (Belden 8281, Belden 1694A or equivalent) at data rates up to 1.485 Gbps.

The LMH0002 provides two selectable slew rates for SMPTE 259M and SMPTE 292M compliance. The output voltage swing is adjustable via a single external resistor.

The LMH0002 is powered from a single 3.3V supply. Power consumption is typically 125 mW in SD mode and 149 mW in HD mode. The LMH0002 is available in an 8-pin SOIC or 16-pin WQFN package.

Typical Application

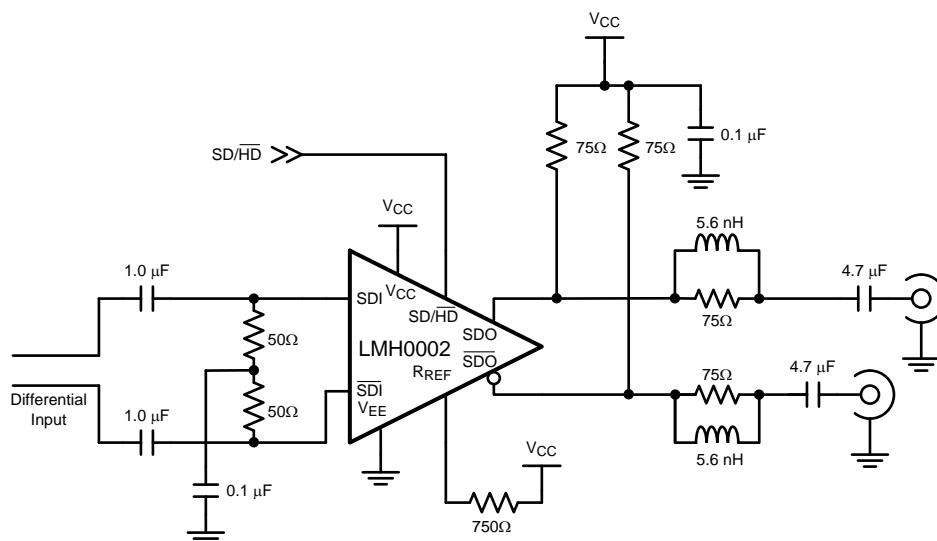

Please be aware that an important notice concerning availability, standard warranty, and use in critical applications of Texas Instruments semiconductor products and disclaimers thereto appears at the end of this data sheet.

All trademarks are the property of their respective owners.



These devices have limited built-in ESD protection. The leads should be shorted together or the device placed in conductive foam during storage or handling to prevent electrostatic damage to the MOS gates.

Absolute Maximum Ratings⁽¹⁾

Supply Voltage:	-0.5V to 3.6V
Input Voltage (all inputs)	-0.3V to $V_{CC}+0.3V$
Output Current	28 mA
Storage Temperature Range	-65°C to +150°C
Junction Temperature	+150°C
Lead Temperature (Soldering 4 Sec)	+260°C
Package Thermal Resistance	
θ_{JA} 8-pin SOIC	+160°C/W
θ_{JA} 16-pin WQFN	+78.9°C/W
θ_{JC} 8-pin SOIC	+105°C/W
θ_{JC} 16-pin WQFN	+42.7°C/W
ESD Rating (HBM)	5kV
ESD Rating (MM)	250V

- (1) "Absolute Maximum Ratings" are those parameter values beyond which the life and operation of the device cannot be ensured. The stating herein of these maximums shall not be construed to imply that the device can or should be operated at or beyond these values. The table of [Electrical Characteristics](#) specifies acceptable device operating conditions.

Recommended Operating Conditions

Supply Voltage ($V_{CC} - V_{EE}$):	3.3V $\pm 5\%$
Operating Free Air Temperature (T_A)	
LMH0002MA	0°C to +70°C
LMH0002TMA and LMH0002SQ	-40°C to +85°C

DC Electrical Characteristics

Over Supply Voltage and Operating Temperature ranges, unless otherwise specified⁽¹⁾⁽²⁾.

Symbol	Parameter	Conditions	Reference	Min	Typ	Max	Units
V_{CMIN}	Input Common Mode Voltage		SDI, \overline{SDI}	$1.6 + V_{SDI}/2$		$V_{CC} - V_{SDI}/2$	V
V_{SDI}	Input Voltage Swing	Differential		100		2000	mV _{P-P}
V_{CMOUT}	Output Common Mode Voltage		SDO, \overline{SDO}		$V_{CC} - V_{SDO}$		V
V_{SDO}	Output Voltage Swing	Single-ended, 75Ω load, $R_{REF} = 750\Omega$ 1%		750	800	850	mV _{P-P}
		Single-ended, 75Ω load, $R_{REF} = 590\Omega$ 1%		900	1000	1100	mV _{P-P}
	SD/ \overline{HD} Input Voltage	Min for SD	SD/ \overline{HD}	2.4			V
		Max for HD				0.8	V
	SD/ \overline{HD} Input Current			3.7			μA
I_{CC}	Supply Current	SD/ $\overline{HD} = 0$ ⁽³⁾			45	49	mA
		SD/ $\overline{HD} = 1$ ⁽³⁾			38	43	mA

(1) Current flow into device pins is defined as positive. Current flow out of device pins is defined as negative. All voltages are stated referenced to $V_{EE} = 0$ Volts.

(2) Typical values are stated for $V_{CC} = +3.3V$ and $T_A = +25^\circ C$.

(3) Maximum I_{CC} is measured at $V_{CC} = +3.465V$ and $T_A = +70^\circ C$.

AC Electrical Characteristics

Over Supply Voltage and Operating Temperature ranges, unless otherwise specified⁽¹⁾.

Symbol	Parameter	Conditions	Reference	Min	Typ	Max	Units
DR_{SDI}	Input Data Rate	⁽²⁾	SDI, \overline{SDI}			1485	Mbps
t_{jit}	Additive Jitter	1.485 Gbps	SDO, \overline{SDO}		26		pS _{P-P}
		270 Mbps			18		pS _{P-P}
t_r, t_f	Output Rise Time, Fall Time	SD/ $\overline{HD} = 0$, 20% – 80%, ⁽³⁾			120	220	ps
		SD/ $\overline{HD} = 1$, 20% – 80%		400	560	800	ps
	Mismatch in Rise/Fall Time	⁽²⁾				30	ps
	Duty Cycle Distortion	SD/ $\overline{HD} = 0$, ⁽²⁾				30	ps
		SD/ $\overline{HD} = 1$, ⁽²⁾				100	ps
t_{OS}	Output Overshoot	⁽²⁾				8	%
RL_{SDO}	Output Return Loss	⁽⁴⁾		15	20		dB

(1) Typical values are stated for $V_{CC} = +3.3V$ and $T_A = +25^\circ C$.

(2) Specification is ensured by characterization.

(3) Specification is ensured by characterization and verified by test.

(4) Output return loss is dependent on board design. The LMH0002 meets this specification on the SD002 evaluation board from 5MHz to 1.5GHz.

CONNECTION DIAGRAM

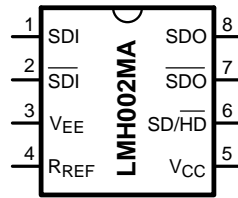

**Figure 1. 8-Pin SOIC
See D Package**

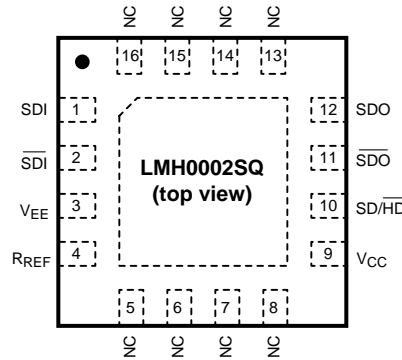

**Figure 2. 16-Pin WQFN
See RUM0016A Package**

Table 1. PIN DESCRIPTIONS

SOIC Pin #	WQFN Pin #	Name	Description
1	1	SDI	Serial data true input.
2	2	$\overline{\text{SDI}}$	Serial data complement input.
3	3	V_{EE}	Negative power supply (ground).
4	4	R_{REF}	Output driver level control. Connect a resistor to V_{CC} to set output voltage swing.
5	9	V_{CC}	Positive power supply (+3.3V).
6	10	$\text{SD}/\overline{\text{HD}}$	Output slew rate control. Output rise/fall time complies with SMPTE 292M when low and SMPTE 259M when high.
7	11	$\overline{\text{SDO}}$	Serial data complement output.
8	12	SDO	Serial data true output.
—	5, 6, 7, 8, 13, 14, 15, 16	NC	No connect.
—	DAP	V_{EE}	Connect exposed DAP to negative power supply (ground).

APPLICATION INFORMATION

Device Operation

INPUT INTERFACING

The LMH0002 accepts either differential or single-ended input. The inputs are self-biased, allowing for simple AC or DC coupling. DC-coupled inputs must be kept within the specified common-mode range. SDI and $\overline{\text{SDI}}$ are self-biased at approximately 2.1V with $V_{CC} = 3.3\text{V}$. Figure 3 shows the differential input stage for SDI and $\overline{\text{SDI}}$.

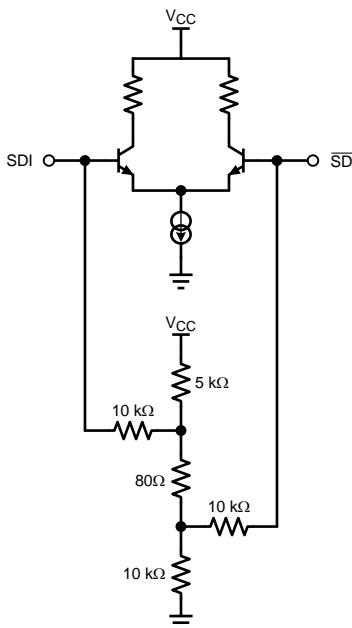

Figure 3. Differential Input Stage for SDI and $\overline{\text{SDI}}$.

OUTPUT INTERFACING

The LMH0002 uses current mode outputs. Single-ended output levels are 800 mV_{P-P} into 75Ω AC-coupled coaxial cable (with $R_{REF} = 750\Omega$). Output level is controlled by the value of the R_{REF} resistor connected between the R_{REF} pin and V_{CC} .

The R_{REF} resistor should be placed as close as possible to the R_{REF} pin. In addition, the copper in the plane layers below the R_{REF} network should be removed to minimize parasitic capacitance.

OUTPUT SLEW RATE CONTROL

The LMH0002 output rise and fall times are selectable for either SMPTE 259M or SMPTE 292M compliance via the SD/HD pin. For slower rise and fall times, or SMPTE 259M compliance, SD/HD is set high. For faster rise and fall times, or SMPTE 292M compliance, SD/HD is set low.

REPLACING THE GENNUM GS1528, GS1528A, and GS1578A

The LMH0002MA is form-fit-function compatible with the Gennum GS1528 and GS1528A. The LMH0002SQ is form-fit-function compatible with the Gennum GS1578A.

REVISION HISTORY

Changes from Revision D (April 2013) to Revision E	Page
• Changed layout of National Data Sheet to TI format	5

PACKAGING INFORMATION

Orderable Device	Status (1)	Package Type	Package Drawing	Pins	Package Qty	Eco Plan (2)	Lead/Ball Finish (6)	MSL Peak Temp (3)	Op Temp (°C)	Device Marking (4/5)	Samples
LMH0002MA/NOPB	ACTIVE	SOIC	D	8	95	Green (RoHS & no Sb/Br)	CU SN	Level-1-260C-UNLIM	-40 to 85	L002	Samples
LMH0002MAX/NOPB	ACTIVE	SOIC	D	8	2500	Green (RoHS & no Sb/Br)	CU SN	Level-1-260C-UNLIM	-40 to 85	L002	Samples
LMH0002SQ	NRND	WQFN	RUM	16	1000	TBD	Call TI	Call TI		L002	
LMH0002SQ/NOPB	ACTIVE	WQFN	RUM	16	1000	Green (RoHS & no Sb/Br)	CU SN	Level-1-260C-UNLIM		L002	Samples
LMH0002SQ/S250	ACTIVE	WQFN	RUM	16	250	Green (RoHS & no Sb/Br)	CU SN	Level-1-260C-UNLIM		L002	Samples
LMH0002SQE/NOPB	ACTIVE	WQFN	RUM	16	250	Green (RoHS & no Sb/Br)	CU SN	Level-1-260C-UNLIM		L002	Samples
LMH0002SQX/NOPB	ACTIVE	WQFN	RUM	16	4500	Green (RoHS & no Sb/Br)	CU SN	Level-1-260C-UNLIM		L002	Samples
LMH0002TMA	NRND	SOIC	D	8		TBD	Call TI	Call TI	-40 to 85	L002T	
LMH0002TMA/NOPB	ACTIVE	SOIC	D	8	95	Green (RoHS & no Sb/Br)	CU SN	Level-1-260C-UNLIM	-40 to 85	L002T	Samples
LMH0002TMAX/NOPB	ACTIVE	SOIC	D	8	2500	Green (RoHS & no Sb/Br)	CU SN	Level-1-260C-UNLIM	-40 to 85	L002T	Samples

(1) The marketing status values are defined as follows:

ACTIVE: Product device recommended for new designs.

LIFEBUY: TI has announced that the device will be discontinued, and a lifetime-buy period is in effect.

NRND: Not recommended for new designs. Device is in production to support existing customers, but TI does not recommend using this part in a new design.

PREVIEW: Device has been announced but is not in production. Samples may or may not be available.

OBSELETE: TI has discontinued the production of the device.

(2) Eco Plan - The planned eco-friendly classification: Pb-Free (RoHS), Pb-Free (RoHS Exempt), or Green (RoHS & no Sb/Br) - please check <http://www.ti.com/productcontent> for the latest availability information and additional product content details.

TBD: The Pb-Free/Green conversion plan has not been defined.

Pb-Free (RoHS): TI's terms "Lead-Free" or "Pb-Free" mean semiconductor products that are compatible with the current RoHS requirements for all 6 substances, including the requirement that lead not exceed 0.1% by weight in homogeneous materials. Where designed to be soldered at high temperatures, TI Pb-Free products are suitable for use in specified lead-free processes.

Pb-Free (RoHS Exempt): This component has a RoHS exemption for either 1) lead-based flip-chip solder bumps used between the die and package, or 2) lead-based die adhesive used between the die and leadframe. The component is otherwise considered Pb-Free (RoHS compatible) as defined above.

Green (RoHS & no Sb/Br): TI defines "Green" to mean Pb-Free (RoHS compatible), and free of Bromine (Br) and Antimony (Sb) based flame retardants (Br or Sb do not exceed 0.1% by weight in homogeneous material)

- (3) MSL, Peak Temp. - The Moisture Sensitivity Level rating according to the JEDEC industry standard classifications, and peak solder temperature.
- (4) There may be additional marking, which relates to the logo, the lot trace code information, or the environmental category on the device.
- (5) Multiple Device Markings will be inside parentheses. Only one Device Marking contained in parentheses and separated by a "~" will appear on a device. If a line is indented then it is a continuation of the previous line and the two combined represent the entire Device Marking for that device.
- (6) Lead/Ball Finish - Orderable Devices may have multiple material finish options. Finish options are separated by a vertical ruled line. Lead/Ball Finish values may wrap to two lines if the finish value exceeds the maximum column width.

Important Information and Disclaimer:The information provided on this page represents TI's knowledge and belief as of the date that it is provided. TI bases its knowledge and belief on information provided by third parties, and makes no representation or warranty as to the accuracy of such information. Efforts are underway to better integrate information from third parties. TI has taken and continues to take reasonable steps to provide representative and accurate information but may not have conducted destructive testing or chemical analysis on incoming materials and chemicals. TI and TI suppliers consider certain information to be proprietary, and thus CAS numbers and other limited information may not be available for release.

In no event shall TI's liability arising out of such information exceed the total purchase price of the TI part(s) at issue in this document sold by TI to Customer on an annual basis.

TAPE AND REEL INFORMATION

QUADRANT ASSIGNMENTS FOR PIN 1 ORIENTATION IN TAPE

*All dimensions are nominal

Device	Package Type	Package Drawing	Pins	SPQ	Reel Diameter (mm)	Reel Width W1 (mm)	A0 (mm)	B0 (mm)	K0 (mm)	P1 (mm)	W (mm)	Pin1 Quadrant
LMH0002MAX/NOPB	SOIC	D	8	2500	330.0	12.4	6.5	5.4	2.0	8.0	12.0	Q1
LMH0002SQ	WQFN	RUM	16	1000	178.0	12.4	4.3	4.3	1.3	8.0	12.0	Q1
LMH0002SQ/NOPB	WQFN	RUM	16	1000	178.0	12.4	4.3	4.3	1.3	8.0	12.0	Q1
LMH0002SQ/S250	WQFN	RUM	16	250	178.0	12.4	4.3	4.3	1.3	8.0	12.0	Q1
LMH0002SQE/NOPB	WQFN	RUM	16	250	178.0	12.4	4.3	4.3	1.3	8.0	12.0	Q1
LMH0002SQX/NOPB	WQFN	RUM	16	4500	330.0	12.4	4.3	4.3	1.3	8.0	12.0	Q1
LMH0002TMAX/NOPB	SOIC	D	8	2500	330.0	12.4	6.5	5.4	2.0	8.0	12.0	Q1

TAPE AND REEL BOX DIMENSIONS

*All dimensions are nominal

Device	Package Type	Package Drawing	Pins	SPQ	Length (mm)	Width (mm)	Height (mm)
LMH0002MAX/NOPB	SOIC	D	8	2500	367.0	367.0	35.0
LMH0002SQ	WQFN	RUM	16	1000	210.0	185.0	35.0
LMH0002SQ/NOPB	WQFN	RUM	16	1000	210.0	185.0	35.0
LMH0002SQ/S250	WQFN	RUM	16	250	210.0	185.0	35.0
LMH0002SQE/NOPB	WQFN	RUM	16	250	210.0	185.0	35.0
LMH0002SQX/NOPB	WQFN	RUM	16	4500	367.0	367.0	35.0
LMH0002TMAX/NOPB	SOIC	D	8	2500	367.0	367.0	35.0

IMPORTANT NOTICE

Texas Instruments Incorporated and its subsidiaries (TI) reserve the right to make corrections, enhancements, improvements and other changes to its semiconductor products and services per JESD46, latest issue, and to discontinue any product or service per JESD48, latest issue. Buyers should obtain the latest relevant information before placing orders and should verify that such information is current and complete. All semiconductor products (also referred to herein as "components") are sold subject to TI's terms and conditions of sale supplied at the time of order acknowledgment.

TI warrants performance of its components to the specifications applicable at the time of sale, in accordance with the warranty in TI's terms and conditions of sale of semiconductor products. Testing and other quality control techniques are used to the extent TI deems necessary to support this warranty. Except where mandated by applicable law, testing of all parameters of each component is not necessarily performed.

TI assumes no liability for applications assistance or the design of Buyers' products. Buyers are responsible for their products and applications using TI components. To minimize the risks associated with Buyers' products and applications, Buyers should provide adequate design and operating safeguards.

TI does not warrant or represent that any license, either express or implied, is granted under any patent right, copyright, mask work right, or other intellectual property right relating to any combination, machine, or process in which TI components or services are used. Information published by TI regarding third-party products or services does not constitute a license to use such products or services or a warranty or endorsement thereof. Use of such information may require a license from a third party under the patents or other intellectual property of the third party, or a license from TI under the patents or other intellectual property of TI.

Reproduction of significant portions of TI information in TI data books or data sheets is permissible only if reproduction is without alteration and is accompanied by all associated warranties, conditions, limitations, and notices. TI is not responsible or liable for such altered documentation. Information of third parties may be subject to additional restrictions.

Resale of TI components or services with statements different from or beyond the parameters stated by TI for that component or service voids all express and any implied warranties for the associated TI component or service and is an unfair and deceptive business practice. TI is not responsible or liable for any such statements.

Buyer acknowledges and agrees that it is solely responsible for compliance with all legal, regulatory and safety-related requirements concerning its products, and any use of TI components in its applications, notwithstanding any applications-related information or support that may be provided by TI. Buyer represents and agrees that it has all the necessary expertise to create and implement safeguards which anticipate dangerous consequences of failures, monitor failures and their consequences, lessen the likelihood of failures that might cause harm and take appropriate remedial actions. Buyer will fully indemnify TI and its representatives against any damages arising out of the use of any TI components in safety-critical applications.

In some cases, TI components may be promoted specifically to facilitate safety-related applications. With such components, TI's goal is to help enable customers to design and create their own end-product solutions that meet applicable functional safety standards and requirements. Nonetheless, such components are subject to these terms.

No TI components are authorized for use in FDA Class III (or similar life-critical medical equipment) unless authorized officers of the parties have executed a special agreement specifically governing such use.

Only those TI components which TI has specifically designated as military grade or "enhanced plastic" are designed and intended for use in military/aerospace applications or environments. Buyer acknowledges and agrees that any military or aerospace use of TI components which have **not** been so designated is solely at the Buyer's risk, and that Buyer is solely responsible for compliance with all legal and regulatory requirements in connection with such use.

TI has specifically designated certain components as meeting ISO/TS16949 requirements, mainly for automotive use. In any case of use of non-designated products, TI will not be responsible for any failure to meet ISO/TS16949.

Products

Audio	www.ti.com/audio
Amplifiers	amplifier.ti.com
Data Converters	dataconverter.ti.com
DLP® Products	www.dlp.com
DSP	dsp.ti.com
Clocks and Timers	www.ti.com/clocks
Interface	interface.ti.com
Logic	logic.ti.com
Power Mgmt	power.ti.com
Microcontrollers	microcontroller.ti.com
RFID	www.ti-rfid.com
OMAP Applications Processors	www.ti.com/omap
Wireless Connectivity	www.ti.com/wirelessconnectivity

Applications

Automotive and Transportation	www.ti.com/automotive
Communications and Telecom	www.ti.com/communications
Computers and Peripherals	www.ti.com/computers
Consumer Electronics	www.ti.com/consumer-apps
Energy and Lighting	www.ti.com/energy
Industrial	www.ti.com/industrial
Medical	www.ti.com/medical
Security	www.ti.com/security
Space, Avionics and Defense	www.ti.com/space-avionics-defense
Video and Imaging	www.ti.com/video

TI E2E Community

e2e.ti.com