

LMP91200 Configurable AFE for Low-Power Chemical-Sensing Applications

1 Features

- Programmable Output Common-Mode Voltage
- Active Guarding
- Onboard Sensor Test
- Supported by WEBENCH® Sensor AFE Designer
- Supported by WEBENCH Sensor Designer Tools
- Key Specifications

Unless otherwise noted, typical values at
 $T_A = 25^\circ\text{C}$, $V_S = (V_{DD} - \text{GND}) = 3.3\text{ V}$

- pH Buffer Input Bias Current ($0 < V_{INP} < 3.3\text{ V}$)
 - Maximum at 25°C : $\pm 125\text{ fA}$
 - Maximum at 85°C : $\pm 445\text{ fA}$
- pH Buffer Input Bias Current ($-500\text{ mV} < V_{INP} - V_{CM} < 500\text{ mV}$), $V_S = (V_{DD} - \text{GND}) = 0\text{ V}$
 - Maximum at 25°C : $\pm 600\text{ fA}$
 - Maximum at 85°C : $\pm 6.5\text{ pA}$
- pH Buffer Input Offset Voltage: $\pm 200\text{ }\mu\text{V}$
- pH Buffer Input Offset Voltage Drift: $\pm 2.5\text{ }\mu\text{V}/^\circ\text{C}$
- Supply Current (pH Mode): $50\text{ }\mu\text{A}$
- Supply Voltage: 1.8 V to 5.5 V
- Operating Temperature Range: -40°C to 125°C
- Package: 16-Pin TSSOP

2 Applications

- pH Sensor Platforms

3 Description

The LMP91200 device is a configurable sensor AFE for use in low-power, analytical-sensing applications. The LMP91200 is designed for 2-electrode sensors. This device provides all of the functionality needed to detect changes based on a delta voltage at the sensor. Optimized for low-power applications, the LMP91200 works over a voltage range of 1.8 V to 5.5 V . With its extremely low input bias current it is optimized for use with pH sensors. Also in absence of supply voltage the very low input bias current reduces degradation of the pH probe when connected to the LMP91200. The Common-Mode Output pin (VOCM) provides a common-mode offset, which can be programmed to different values to accommodate pH sensor output ranges. For applications requiring a high-impedance common mode, this option is also available. Two guard pins provide support for high parasitic impedance wiring. The control of this feature is available through the SPI interface. Additionally, a user-controlled sensor diagnostic test is available. This function tests the sensor for proper connection and functionality. Depending on the configuration, total current consumption for the device is $50\text{ }\mu\text{A}$ while measuring pH. Available in a 16-pin TSSOP package, the LMP91200 operates from -40°C to $+125^\circ\text{C}$.

Device Information⁽¹⁾

PART NUMBER	PACKAGE	BODY SIZE (NOM)
LMP91200	TSSOP (16)	5.00 mm x 4.40 mm

(1) For all available packages, see the orderable addendum at the end of the data sheet.

Typical Application

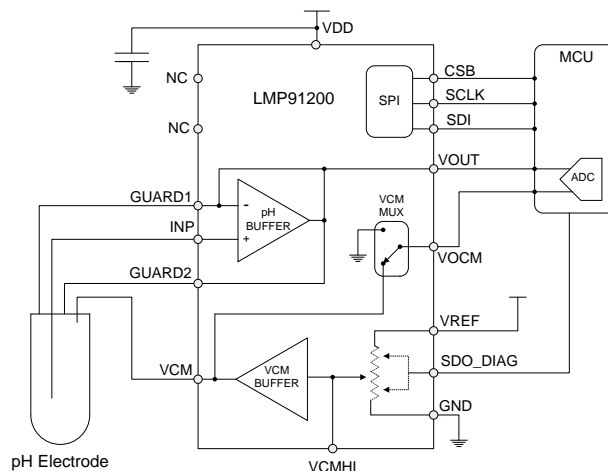

Table of Contents

1 Features	1	8.2 Functional Block Diagram	16
2 Applications	1	8.3 Feature Description	17
3 Description	1	8.4 Device Functional Modes	17
4 Revision History	2	8.5 Programming	17
5 Pin Configuration and Functions	3	8.6 Register Maps	18
6 Specifications	4	9 Application and Implementation	19
6.1 Absolute Maximum Ratings	4	9.1 Application Information	19
6.2 ESD Ratings	4	9.2 Typical Application	20
6.3 Recommended Operating Conditions	4	10 Power Supply Recommendations	22
6.4 Thermal Information	4	11 Layout	22
6.5 Electrical Characteristics	5	11.1 Layout Guidelines	22
6.6 Electrical Characteristics (Serial Interface)	7	11.2 Layout Example	22
6.7 Electrical Characteristics (Diagnostic)	8	12 Device and Documentation Support	23
6.8 Typical Characteristics	9	12.1 Community Resources	23
7 Parameter Measurement Information	16	12.2 Trademarks	23
7.1 Test Circuit Diagram	16	12.3 Electrostatic Discharge Caution	23
8 Detailed Description	16	12.4 Glossary	23
8.1 Overview	16	13 Mechanical, Packaging, and Orderable Information	23

4 Revision History

NOTE: Page numbers for previous revisions may differ from page numbers in the current version.

Changes from Revision C (March 2013) to Revision D	Page
<ul style="list-style-type: none"> Added <i>Pin Configuration and Functions</i> section, <i>ESD Ratings</i> table, <i>Feature Description</i> section, <i>Device Functional Modes</i>, <i>Application and Implementation</i> section, <i>Power Supply Recommendations</i> section, <i>Layout</i> section, <i>Device and Documentation Support</i> section, and <i>Mechanical, Packaging, and Orderable Information</i> section 	1

Changes from Revision B (March 2013) to Revision C	Page
<ul style="list-style-type: none"> Changed layout of National Data Sheet to TI format 	22

5 Pin Configuration and Functions

**PW Package
16-Pin TSSOP
Top View**

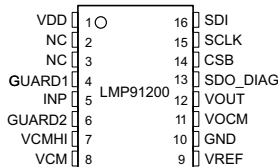

Pin Functions⁽¹⁾

PIN		TYPE	DESCRIPTION
NO.	NAME		
1	VDD	P	Positive Power Supply
2	NC	A	No connect. These pins should be left floating
3	NC	A	No connect. These pins should be left floating
4	GUARD1	A	Active guard pin
5	INP	A	Noninverting analog input of pH buffer
6	GUARD2	A	Active guard pin
7	VCMHI	A	High Impedance Programmable Common-Mode output
8	VCM	A	Buffered Programmable Common-Mode output
9	VREF	A	Voltage reference input
10	GND	G	Analog ground
11	VOVM	A	Output common-mode voltage
12	VOUT	A	Analog Output
13	SDO_DIAG	D	Serial Data Out / Diagnostic enable
14	CSB	D	Chip select, low-active.
15	SCLK	D	Serial Clock
16	SDI	D	Serial Data In

(1) D = Digital, A = Analog, P = Power, G = GND

6 Specifications

6.1 Absolute Maximum Ratings

 over operating free-air temperature range (unless otherwise noted)⁽¹⁾⁽²⁾⁽³⁾

	MIN	MAX	UNIT
Supply Voltage ($V_S = V_{DD} - GND$)	-0.3	6	V
Voltage between any two pins	-0.3	$V_{DD} + 0.3$	V
Current out at any pin		5	mA
Junction Temperature ⁽⁴⁾		150	°C
Storage Temperature, T_{stg}	-65	150	°C

- (1) Stresses beyond those listed under *Absolute Maximum Ratings* may cause permanent damage to the device. These are stress ratings only, which do not imply functional operation of the device at these or any other conditions beyond those indicated under *Recommended Operating Conditions*. Exposure to absolute-maximum-rated conditions for extended periods may affect device reliability.
- (2) For soldering specifications see product folder at www.ti.com and [SNOA549](#)
- (3) If Military/Aerospace specified devices are required, please contact the Texas Instruments Sales Office/ Distributors for availability and specifications.
- (4) The maximum power dissipation is a function of $T_{J(MAX)}$, $R_{\theta JA}$. The maximum allowable power dissipation at any ambient temperature is $P_D = (T_{J(MAX)} - T_A)/R_{\theta JA}$. All numbers apply for packages soldered directly onto a PCB.

6.2 ESD Ratings

		VALUE	UNIT
$V_{(ESD)}$ Electrostatic discharge ⁽¹⁾	Human body model (HBM), per ANSI/ESDA/JEDEC JS-001 ⁽²⁾	±2000	V
	Charged-device model (CDM), per JEDEC specification JESD22-C101 ⁽³⁾	±1000	
	Machine Model	±150	

- (1) Human Body Model, applicable std. MIL-STD-883, Method 3015.7. Machine Model, applicable std. JESD22-A115-A (ESD MM std. of JEDEC) Field-Induced Charge-Device Model, applicable std. JESD22-C101-C (ESD FICDM std. of JEDEC).
- (2) JEDEC document JEP155 states that 500-V HBM allows safe manufacturing with a standard ESD control process.
- (3) JEDEC document JEP157 states that 250-V CDM allows safe manufacturing with a standard ESD control process.

6.3 Recommended Operating Conditions

over operating free-air temperature range (unless otherwise noted)

	MIN	MAX	UNIT
Supply Voltage ($V_S = V_{DD} - GND$)	1.8	5.5	V
Temperature	-40	125	°C

6.4 Thermal Information

THERMAL METRIC ⁽¹⁾		LMP91200	UNIT
		PW (TSSOP)	
		16 PINS	
$R_{\theta JA}$	Junction-to-ambient thermal resistance	31	°C/W

- (1) For more information about traditional and new thermal metrics, see the *Semiconductor and IC Package Thermal Metrics* application report, [SPRA953](#).

6.5 Electrical Characteristics

Unless otherwise specified, all limits specified for $T_A = 25^\circ\text{C}$. $V_S = (V_{DD} - GND) = 3.3\text{ V}$. $V_{REF} = 3.3\text{ V}$. ⁽¹⁾⁽²⁾⁽³⁾

PARAMETER		TEST CONDITIONS		MIN ⁽⁴⁾	TYP ⁽⁵⁾	MAX ⁽⁴⁾	UNIT
POWER SUPPLY							
I_S	Supply Current ⁽⁶⁾⁽⁷⁾	pH measurement mode	at the temperature extremes		50	54	μA
						59	
pH BUFFER							
$A_{ol_{pH}}$	Open-loop Gain	INP = 1.65 V, 300 mV = VOUT = VDD – 300 mV	at the temperature extremes		120		dB
					90		
$V_{OS_{pH}}$	Input Voltage Offset ⁽⁶⁾	INP = 1/8 VREF	at the temperature extremes		-200	200	μV
					-350	350	
		INP = 7/8 VREF	at the temperature extremes		-200	200	
					-350	350	
$T_C V_{OS_{pH}}$	Input offset voltage drift ⁽⁸⁾⁽⁹⁾	INP = 1/8 VREF		-2.5		2.5	$\mu\text{V}/^\circ\text{C}$
		INP = 7/8 VREF		-2.5		2.5	
$V_{OS_{pH_drift}}$	Long-term $V_{OS_{pH}}$ drift ⁽¹⁰⁾	500 hours OPL			150		μV
$I_{b_{pH}}$	Input bias current at INP ⁽⁹⁾	0 V < INP < 3.3 V		-125		125	fA
		0 V < INP < 3.3 V, 85°C		-445		445	fA
		0 V < INP < 3.3 V, 125°C		-1.5		1.5	pA
		-500 mV < (INP – VCM) < 500 mV, $V_S = 0\text{ V}$.		-600		600	fA
		-500 mV < (INP – VCM) < 500 mV, 85°C, $V_S = 0\text{ V}$.		-6.5		6.5	pA
		-500 mV < (INP – VCM) < 500 mV, 125°C, $V_S = 0\text{ V}$.		-100		100	pA
GBW_{pH}	Gain Bandwidth Product ⁽⁹⁾	$C_L = 10\text{ pF}$, $R_L = 1\text{ M}\Omega$			220		KHz
$CMRR_{pH}$	DC_Common-mode rejection ratio	1/8 VREF < INP < 7/8 VREF		80			dB
$PSRR_{pH}$	DC_Power supply rejection ratio	1.8 V < VDD < 5 V INP = 1/8 VREF		80			dB
		1.8 V < VDD < 5 V INP = 7/8 VREF		80			
$E_{n_RMS_{pH}}$	Input referred noise (low frequency) ⁽⁹⁾	Integrated 0.1 Hz to 10 Hz			2.6		μV_{PP}
$e_{n_{pH}}$	Input referred noise (high frequency) ⁽⁹⁾	$f = 1\text{ kHz}$			90		$\text{nV}/\sqrt{\text{Hz}}$

- (1) Electrical Table values apply only for factory testing conditions at the temperature indicated. Factory testing conditions result in very limited self-heating of the device such that $T_J = T_A$. No specification of parametric performance is indicated in the electrical tables under conditions of internal self-heating where $T_J > T_A$.
- (2) Positive current corresponds to current flowing into the device.
- (3) The voltage on any pin should not exceed 6 V relative to any other pins.
- (4) Limits are 100% production tested at 25°C. Limits over the operating temperature range are specified through correlations using the Statistical Quality Control (SQC) method.
- (5) Typical values represent the most likely parametric norm as determined at the time of characterization. Actual typical values may vary over time and will also depend on the application and configuration. The typical values are not tested and are not specified on shipped production material.
- (6) Boldface limits are production tested at 125°C. Limits are specified through correlations using the Statistical Quality Control (SQC) method.
- (7) Excluding all currents which flows out from the device.
- (8) Offset voltage average drift is determined by dividing the change in V_{OS} at the temperature extremes by the total temperature change.
- (9) This parameter is specified by design and/or characterization and is not tested in production.
- (10) Offset voltage long term drift is determined by dividing the change in V_{OS} at time extremes of OPL procedure by the length of the OPL procedure. OPL procedure: 500 hours at 150°C are equivalent to about 15 years.

Electrical Characteristics (continued)

 Unless otherwise specified, all limits specified for $T_A = 25^\circ\text{C}$. $V_S = (V_{DD} - GND) = 3.3\text{ V}$. $V_{REF} = 3.3\text{ V}$.⁽¹⁾⁽²⁾⁽³⁾

PARAMETER		TEST CONDITIONS		MIN ⁽⁴⁾	TYP ⁽⁵⁾	MAX ⁽⁴⁾	UNIT
I _{SCpH}	Output short circuit current ⁽¹¹⁾	Sourcing, V _{out} to GND, INP = 1.65 V			13		mA
			at the temperature extremes	10			
		Sinking, V _{out} to VDD, INP = 1.65 V			12		mA
			at the temperature extremes	8			
VCM BUFFER							
VCMHI_acc	VCMHI accuracy			-1.6		1.6	mV
T _{c_VCMHI}	VCMHI temperature coefficient ⁽⁹⁾⁽¹²⁾	-40°C < T _A < 125°C		-18	-5	8	μV/°C
VCMHI_acc_VREF	VCMHI_acc vs. VREF ⁽⁹⁾⁽¹³⁾	1.8 V < VREF < 5 V		-500	-100	300	μV/V
R _{out_VCMHI}	VCMHI Output Impedance ⁽⁹⁾	VCMHI = 1/2 VREF			250		KΩ
A _{ol_VCM}	Open-loop Gain ⁽⁶⁾	VCMHI = 1/2 VREF, 300 mV < VCM < VDD - 300 mV			120		dB
			at the temperature extremes	90			
V _{os_VCM}	(VCM - VCMHI) ⁽⁶⁾	VCMHI = 1/8 VREF			-200	200	μV
			at the temperature extremes	-350	350		
		VCMHI = 7/8 VREF			-200	200	
			at the temperature extremes	-350	350		
T _{cVos_VCM}	Input offset voltage drift (VCM-VCMHI) ⁽⁸⁾⁽⁹⁾	VCMHI = 1/8 VREF		-2.5		2.5	μV/°C
		VCMHI = 7/8 VREF		-2.5		2.5	
Z _{out_VCM}	Output Impedance ⁽⁹⁾	f = 1 KHz			4		Ω
PSRR _{VCM}	DC_Power supply rejection ratio	1.8 V < VDD < 5 V, VCMHI = 1/8 VREF		80			dB
		1.8 V < VDD < 5 V, VCMHI = 7/8 VREF		80			
En_RMS_VCM	Input referred noise (low frequency) ⁽⁹⁾	Integrated 0.1 Hz to 10 Hz			2.6		μV _{PP}
en_VCM	Input referred noise (high frequency) ⁽⁹⁾	f = 1 KHz			90		nV/√Hz
I _{sc_VCM}	Output short circuit current ⁽¹¹⁾	Sourcing, V _{out} to GND, VCMHI = 1/2 VREF			16		mA
			at the temperature extremes	10			
		Sinking, V _{out} to VDD, VCMHI = 1/2 VREF			12		
			at the temperature extremes	8			
PGA							
V _{os_PGA}	Input Voltage Offset ⁽⁶⁾	+IN_PGA (Internal node) = 500 mV			-275	275	μV
			at the temperature extremes	-480	480		
T _{cVos_PGA}	Input offset voltage drift ⁽⁹⁾⁽⁸⁾	+IN_PGA (Internal node) = 500 mV		-2.5		2.5	uV/°C
A _{ol_PGA}	Open loop Gain	+IN_PGA (Internal node) = 500 mV			120		dB
			at the temperature extremes	90			
A _{V_PGA}	Gain	Programmable gain			5	10	V/V

(11) The short circuit test is a momentary open-loop test.

(12) VCMHI voltage average drift is determined by dividing the change in VCMHI at the temperature extremes by the total temperature change.

(13) VCMHI_acc vs. VREF is determined by dividing the change in VCMHI_acc at the VREF extremes by the total VREF change.

Electrical Characteristics (continued)

Unless otherwise specified, all limits specified for $T_A = 25^\circ\text{C}$. $V_S = (V_{DD} - GND) = 3.3\text{ V}$. $V_{REF} = 3.3\text{ V}$.⁽¹⁾⁽²⁾⁽³⁾

PARAMETER		TEST CONDITIONS	MIN ⁽⁴⁾	TYP ⁽⁵⁾	MAX ⁽⁴⁾	UNIT
AV_accPGA	Gain accuracy	at the temperature extremes	-1.3%		1.3%	
En_RMSPGA	Input referred noise (low frequency) ⁽⁹⁾	Integrated 0.1 Hz to 10 Hz		2.6		μV_{PP}
enPGA	Input referred noise (high frequency) ⁽⁹⁾	f = 1 kHz		90		$\text{nV}/\sqrt{\text{Hz}}$
PSRRPGA	DC_Power supply rejection ratio	1.8 V < VDD < 5 V, +IN_PGA (Internal node) = 500 mV	80			dB
ISCPGA	Output short circuit current ⁽¹¹⁾	Sourcing, Vout to GND +IN_PGA (Internal node) = 500 mV		16		mA
			at the temperature extremes	10		
		Sinking, Vout to VDD +IN_PGA (Internal node) = 500 mV		12		
		at the temperature extremes	8			
REFERENCE INPUT						
RinVREF	Input impedance ⁽⁹⁾			500		K Ω

6.6 Electrical Characteristics (Serial Interface)

Unless otherwise specified. All limits specified for $T_A = 25^\circ\text{C}$, $V_S = (V_{DD} - GND) = 3.3\text{ V}$.⁽¹⁾

PARAMETER	TEST CONDITIONS	MIN ⁽²⁾	TYP ⁽³⁾	MAX ⁽²⁾	UNIT
VIL	Logic Low Threshold			0.3 × VDD	V
VIH	Logic High Threshold (SDO pin)			0.7 × VDD	V
VOL	Output Logic LOW Threshold (SDO pin)	ISDO = 100 μA		0.2	V
		ISDO = 2 mA		0.4	
VOH	Output Logic High Threshold	ISDO = 100 μA		VDD – 0.2	V
		ISDO = 2 mA		VDD – 0.4	
t1	High Period, SCLK		100		ns
t2	Low Period, SCLK		100		ns
t3	Set-up Time, CSB to SCLK	See ⁽⁴⁾		50	ns
t4	Set-up Time, SDI to SCLK			30	ns
t5	Hold Time, SCLK to SDI			10	ns
t6	Hold Time, SCLK to SDO_DIAG			40	ns
t7	Hold Time, SCLK Transition to CSB Rising Edge			50	ns
t8	CSB Inactive			50	ns
t9	Hold Time, SCLK Transition to CSB Falling Edge	See ⁽⁴⁾		10	ns
tR/tF	SDO_DIAG Signal Rise and Fall Times	Diagnostic disabled ⁽⁴⁾⁽⁵⁾		30	ns

- (1) Electrical Table values apply only for factory testing conditions at the temperature indicated. Factory testing conditions result in very limited self-heating of the device such that $T_J = T_A$. No specification of parametric performance is indicated in the electrical tables under conditions of internal self-heating where $T_J > T_A$.
- (2) Limits are 100% production tested at 25°C. Limits over the operating temperature range are specified through correlations using the Statistical Quality Control (SQC) method.
- (3) Typical values represent the most likely parametric norm as determined at the time of characterization. Actual typical values may vary over time and will also depend on the application and configuration. The typical values are not tested and are not specified on shipped production material.
- (4) Load for these tests is shown in the timing diagram test circuit.
- (5) This parameter is specified by design and/or characterization and is not tested in production.

6.7 Electrical Characteristics (Diagnostic)

Unless otherwise specified. All limits specified for $T_A = 25^\circ\text{C}$, $V_S = (V_{DD} - GND) = 3.3\text{ V}$.⁽¹⁾

PARAMETER	TEST CONDITIONS	MIN ⁽²⁾	TYP ⁽³⁾	MAX ⁽²⁾	UNIT
DIAG_tSET	SDO_DIAG set-up time ⁽⁴⁾		200		ns
DIAG_tR/DIAG_tF	Diagnostic Rise and Fall Times (Signal at SDO_DIAG pin, in Diagnostic Mode) ⁽⁴⁾		30		ns
DIAG_tON	Minimum t _{ON} of the diagnostic pulse at SDO_DIAG pin in Diagnostic Mode ⁽⁴⁾		100		ns
VCM_DIAG_POS	Positive Diagnostic pulse amplitude ⁽⁴⁾	Base pulse = VCM; High level pulse = VCM + 5% VREF	165		mV
VCM_DIAG_NEG	Negative Diagnostic pulse amplitude ⁽⁴⁾	Base pulse = VCM; High level pulse = VCM – 5% VREF	165		mV
VCM_DIAG_acc	Diagnostics Pulse accuracy ⁽⁴⁾		0.1%		
VCM_DIAG_tR	Diagnostics Pulse rise time ⁽⁴⁾	10% to 90%, C = 15 pF	10		us
VCM_DIAG_tF	Diagnostics Pulse fall time ⁽⁴⁾	90% to 10%, C = 15 pF	10		us

- (1) Electrical Table values apply only for factory testing conditions at the temperature indicated. Factory testing conditions result in very limited self-heating of the device such that $T_J = T_A$. No specification of parametric performance is indicated in the electrical tables under conditions of internal self-heating where $T_J > T_A$.
- (2) Limits are 100% production tested at 25°C. Limits over the operating temperature range are specified through correlations using the Statistical Quality Control (SQC) method.
- (3) Typical values represent the most likely parametric norm as determined at the time of characterization. Actual typical values may vary over time and will also depend on the application and configuration. The typical values are not tested and are not specified on shipped production material.
- (4) This parameter is specified by design and/or characterization and is not tested in production.

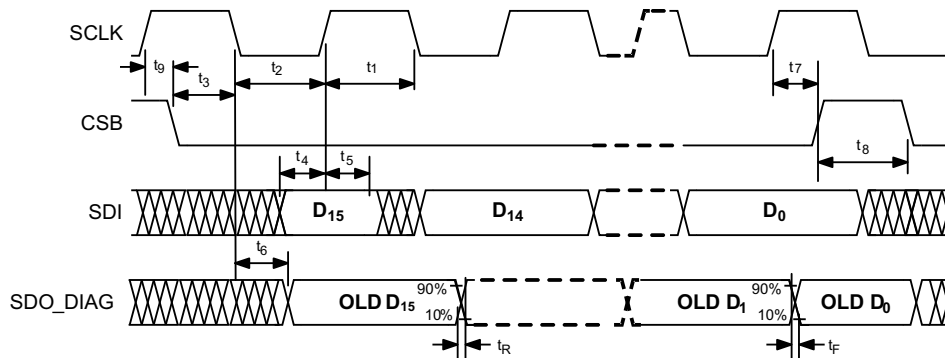

Figure 1. Serial Interface Timing Diagram

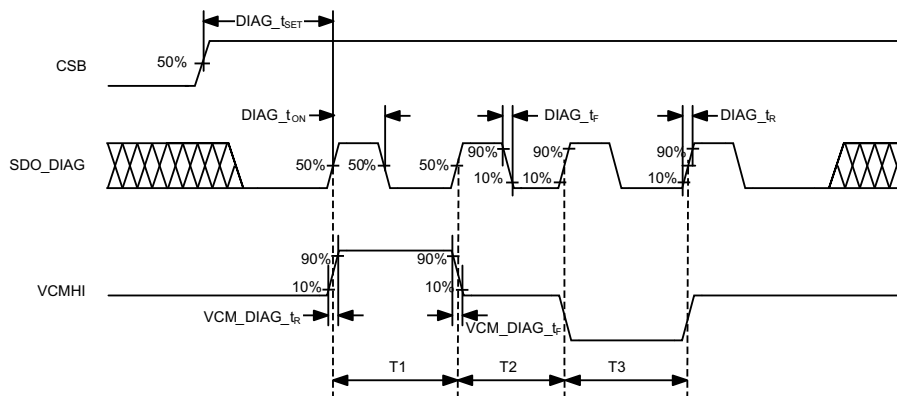

Figure 2. Diagnostic Timing Diagram

6.8 Typical Characteristics

Unless otherwise specified, $T_A = 25^\circ\text{C}$, $V_S = (V_{DD} - GND) = 3.3\text{ V}$, $V_{REF} = 3.3\text{ V}$.

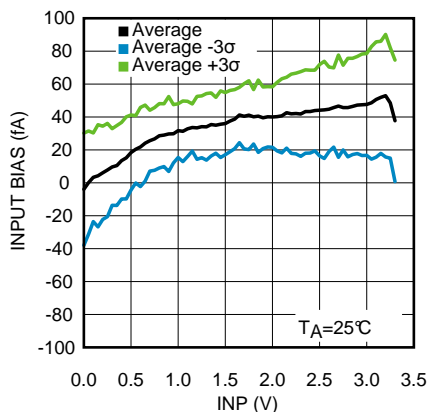

Figure 3. pH Buffer Input Bias Current vs V_{INP} - Device ON

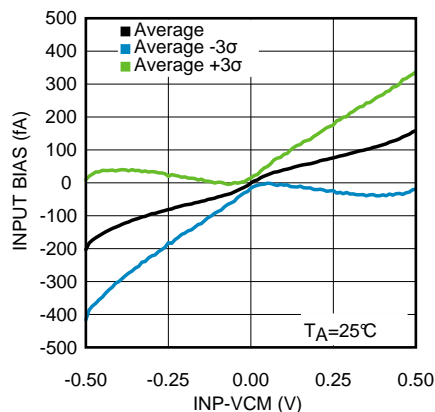

Figure 4. pH Buffer Input Bias Current vs V_{INP} - Device OFF

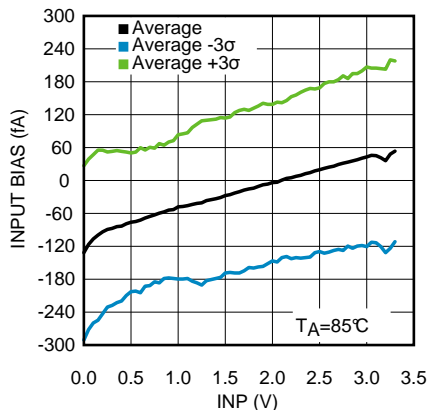

Figure 5. pH Buffer Input Bias Current vs V_{INP} - Device ON

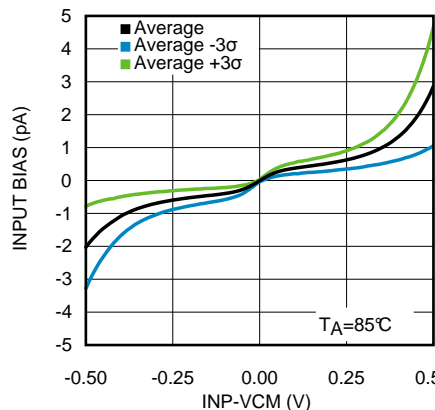

Figure 6. pH Buffer Input Bias Current vs V_{INP} - Device OFF

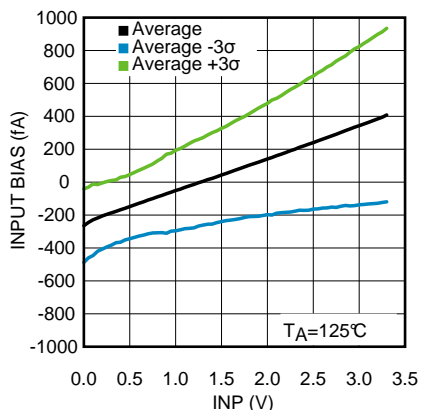

Figure 7. pH Buffer Input Bias Current vs V_{INP} - Device ON

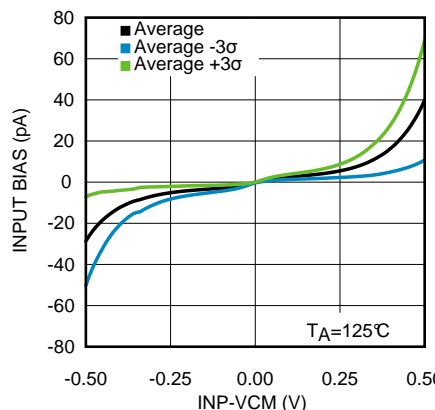

Figure 8. pH Buffer Input Bias Current vs V_{INP} - Device OFF

Typical Characteristics (continued)

Unless otherwise specified, $T_A = 25^\circ\text{C}$, $V_S = (V_{DD} - GND) = 3.3\text{ V}$, $V_{REF} = 3.3\text{ V}$.

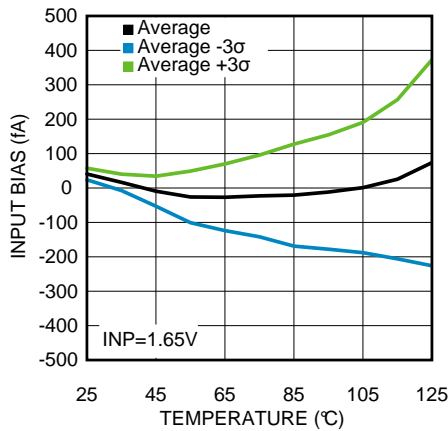

Figure 9. pH Buffer Input Bias Current vs Temp - Device ON

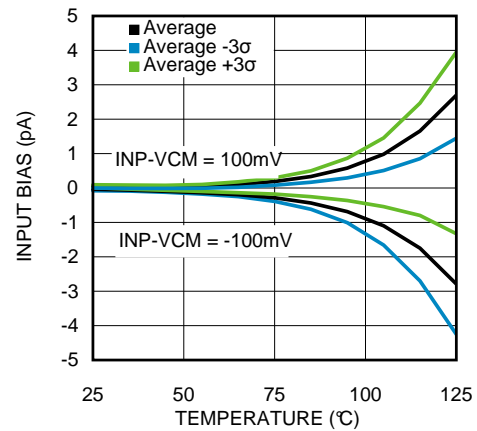

Figure 10. pH Buffer Input Bias Current vs Temp - Device OFF

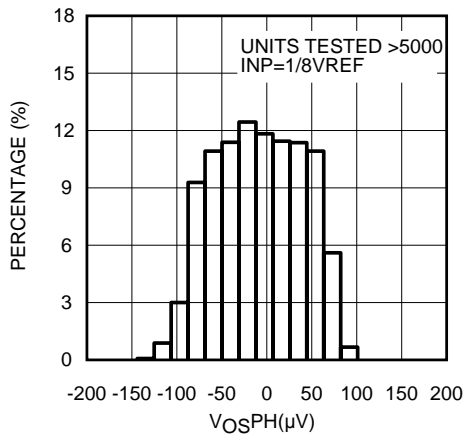

Figure 11. pH Buffer Input Voltage Offset

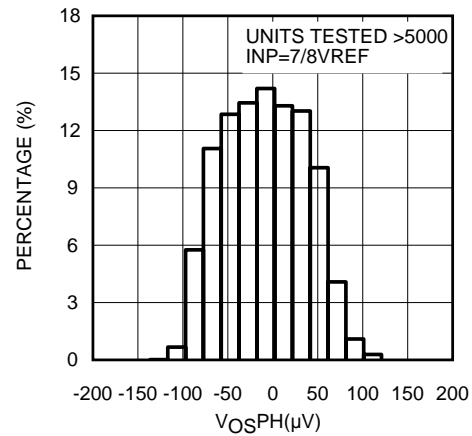

Figure 12. pH Buffer Input Voltage Offset

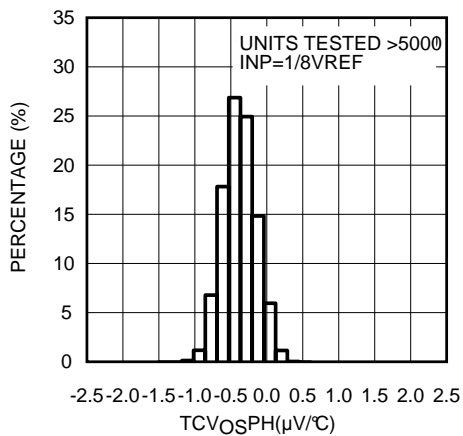

Figure 13. pH Buffer TCV_{Os}

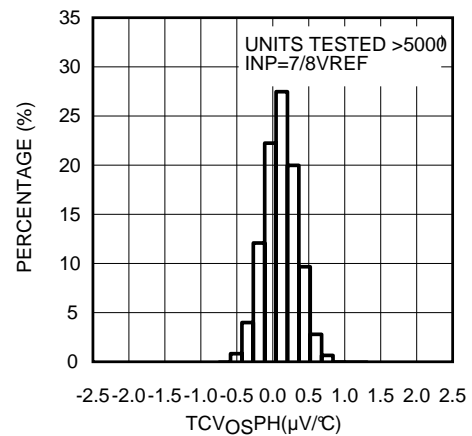

Figure 14. pH Buffer TCV_{Os}

Typical Characteristics (continued)

Unless otherwise specified, $T_A = 25^\circ\text{C}$, $V_S = (V_{DD} - GND) = 3.3\text{ V}$, $V_{REF} = 3.3\text{ V}$.

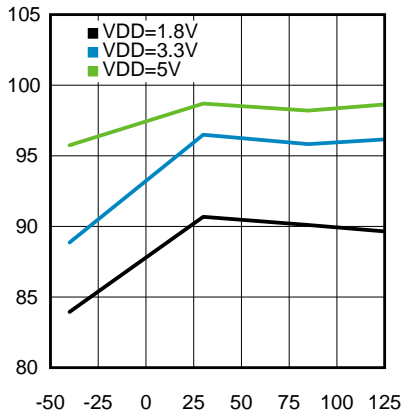

Figure 15. pH Buffer DC CMRR vs Temperature

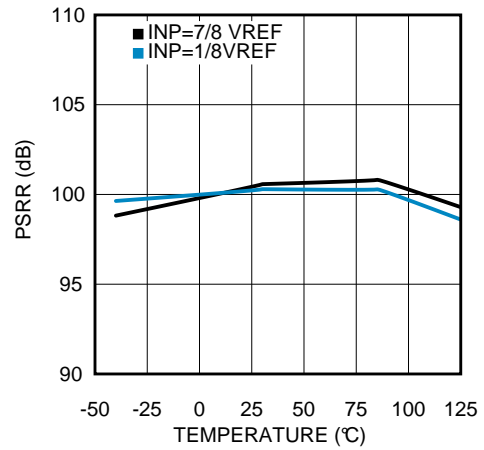

Figure 16. pH Buffer DC PSRR vs Temperature

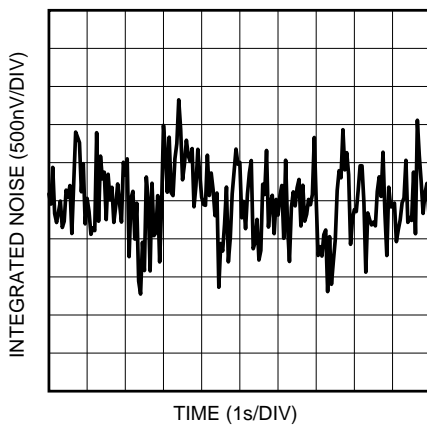

Figure 17. pH Buffer Time Domain Voltage Noise

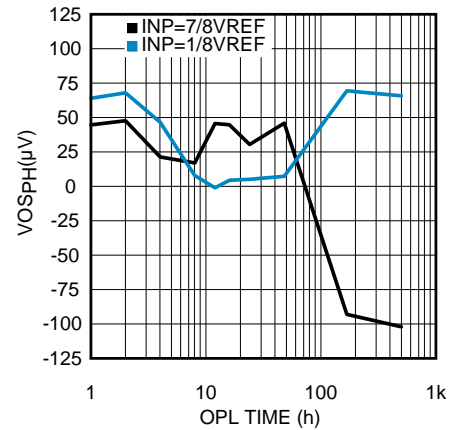

Figure 18. pH Buffer Input Offset Voltage Drift

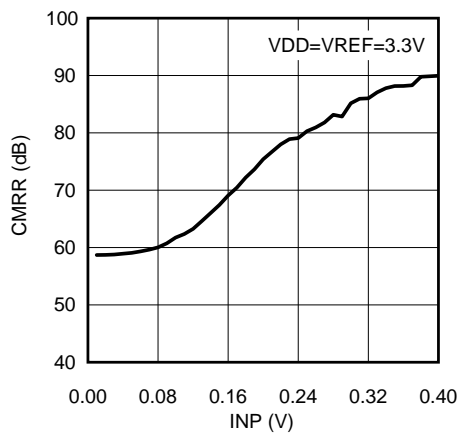

Figure 19. pH Buffer CMRR vs V_{INP} - Lower Rail

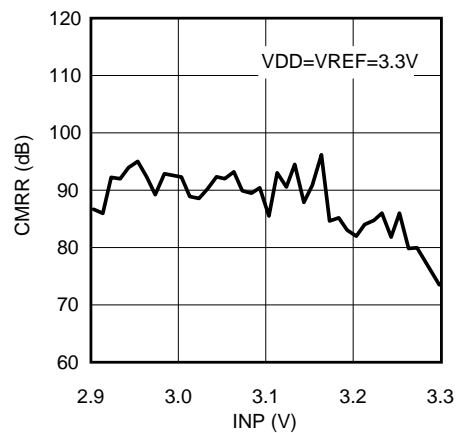

Figure 20. pH Buffer CMRR vs V_{INP} - upper rail

Typical Characteristics (continued)

Unless otherwise specified, $T_A = 25^\circ\text{C}$, $V_S = (V_{DD} - GND) = 3.3\text{ V}$, $V_{REF} = 3.3\text{ V}$.

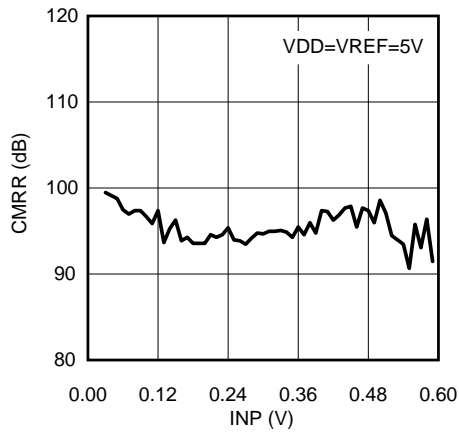

Figure 21. pH Buffer CMRR vs V_{INP} - lower rail

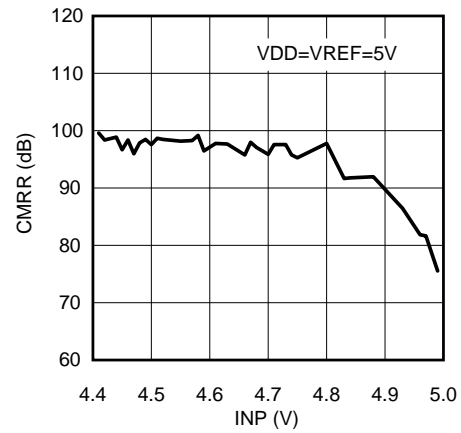

Figure 22. pH Buffer CMRR vs V_{INP} - upper rail

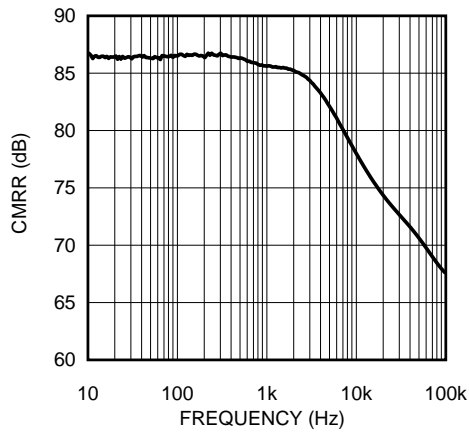

Figure 23. pH Buffer CMRR vs Frequency

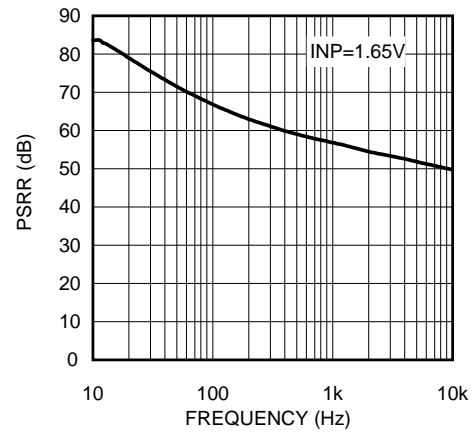

Figure 24. pH Buffer PSRR vs Frequency

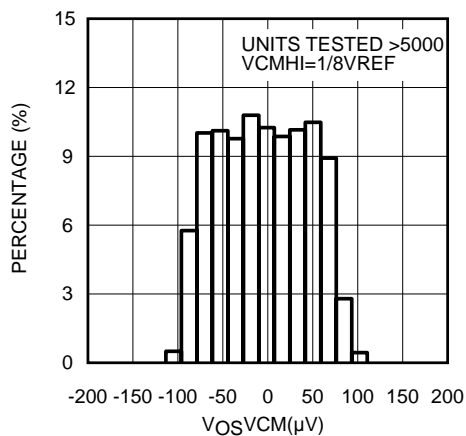

Figure 25. VCM Buffer Input Voltage Offset

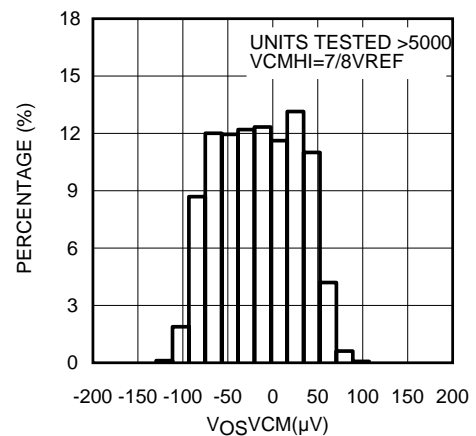

Figure 26. VCM Buffer Input Voltage Offset

Typical Characteristics (continued)

Unless otherwise specified, $T_A = 25^\circ\text{C}$, $V_S = (V_{DD} - GND) = 3.3\text{ V}$, $V_{REF} = 3.3\text{ V}$.

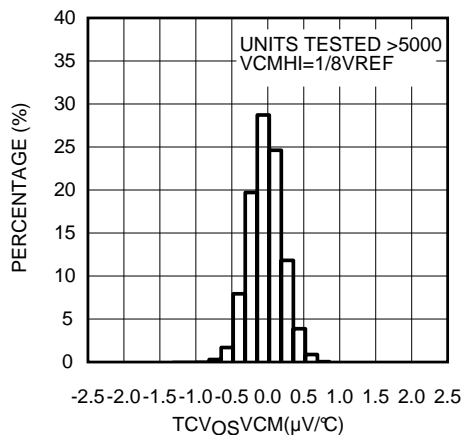

Figure 27. VCM Buffer TCvos

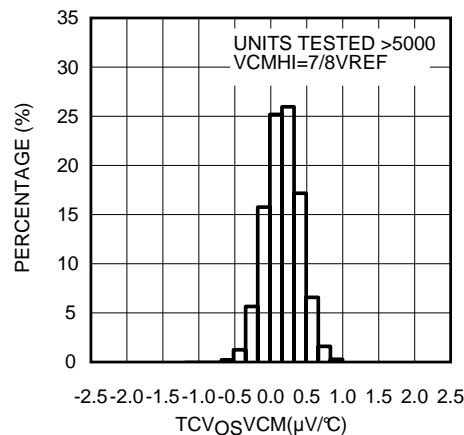

Figure 28. VCM Buffer TcVos

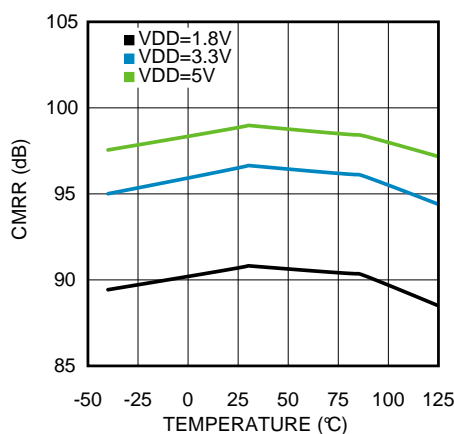

Figure 29. VCM Buffer DC CMRR vs Temperature

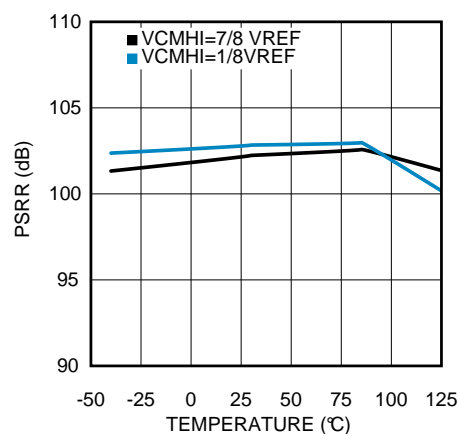

Figure 30. VCM Buffer DC PSRR vs Temperature

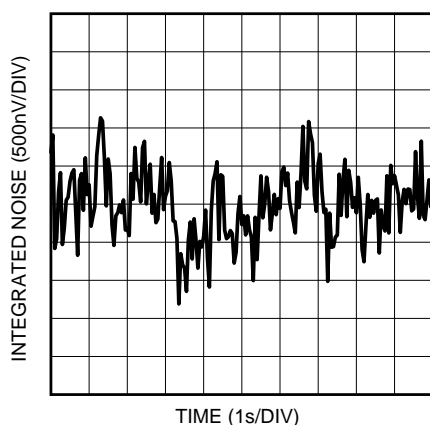

Figure 31. VCM Buffer Time Domain Voltage Noise

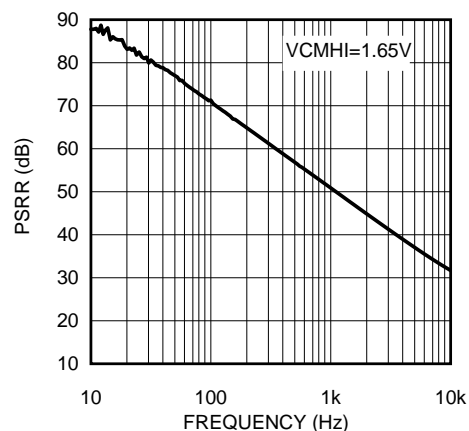

Figure 32. VCM Buffer PSRR vs Frequency

Typical Characteristics (continued)

Unless otherwise specified, $T_A = 25^\circ\text{C}$, $V_S = (V_{DD} - GND) = 3.3\text{ V}$, $V_{REF} = 3.3\text{ V}$.

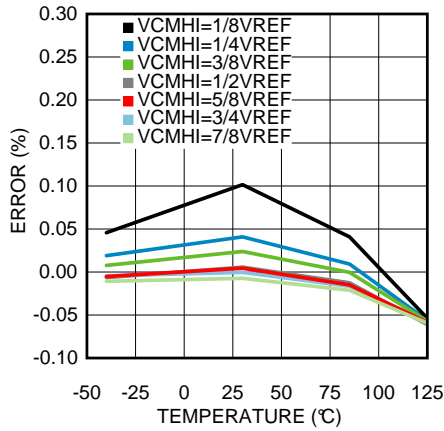

Figure 33. VCMHI Error vs Temp

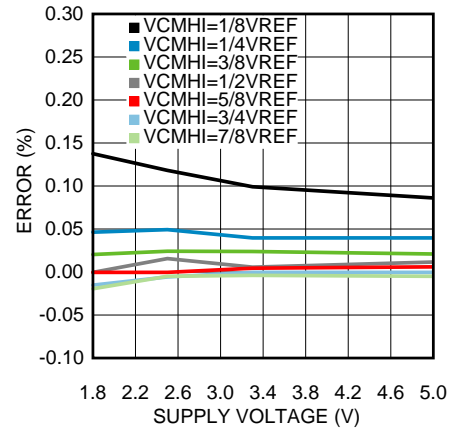

Figure 34. VCMHI Error vs Supply Voltage

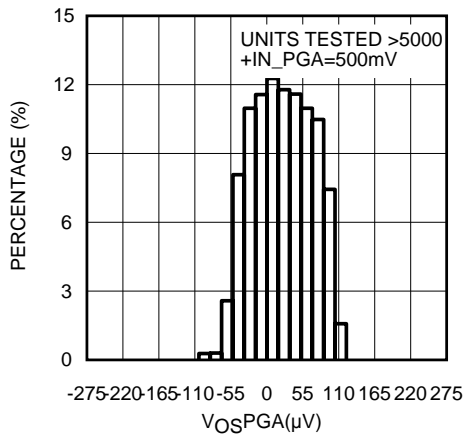

Figure 35. PGA Input Voltage Offset

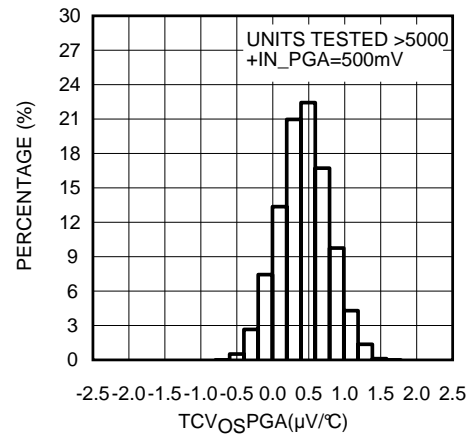

Figure 36. PGA TCV_{Os}

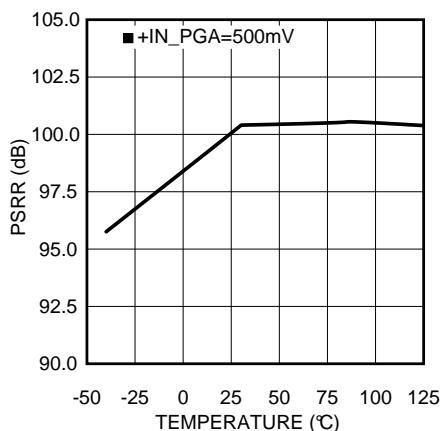

Figure 37. PGA DC PSRR vs Temperature

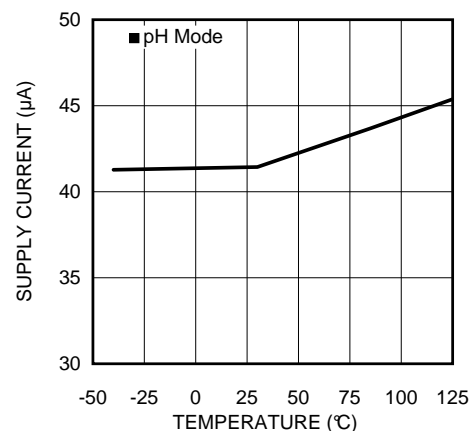

Figure 38. Supply Current (pH Mode) vs Temperature

Typical Characteristics (continued)

Unless otherwise specified, $T_A = 25^\circ\text{C}$, $V_S = (V_{DD} - GND) = 3.3\text{ V}$, $V_{REF} = 3.3\text{ V}$.

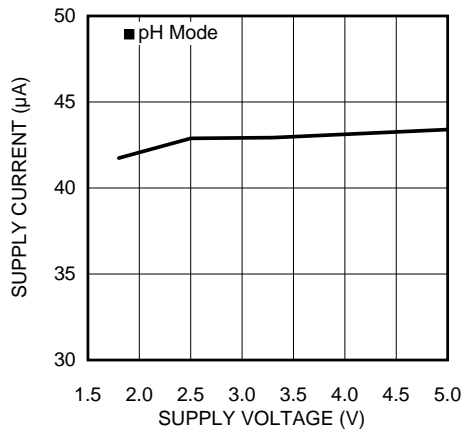

Figure 39. Supply Current (pH Mode) vs Supply Voltage

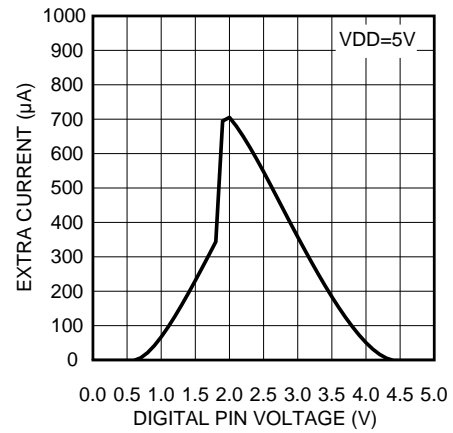
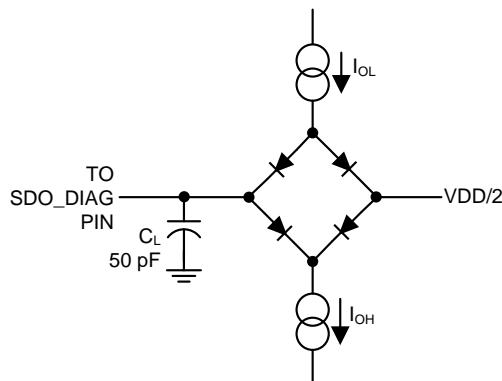

Figure 40. Supply current vs Digital Input Voltage

7 Parameter Measurement Information

7.1 Test Circuit Diagram



8 Detailed Description

8.1 Overview

The LMP91200 is a configurable sensor AFE for use in low-power, analytical-sensing applications. The LMP91200 is designed for 2-electrode sensors. This device provides all of the functionality needed to detect changes based on a delta voltage at the sensor. Optimized for low-power applications, the LMP91200 works over a voltage range of 1.8 V to 5.5 V. With its extremely low input bias current, it is optimized for use with pH sensors. Also, in the absence of supply voltage, the very low input bias current reduces degradation of the pH probe when connected to the LMP91200. The Common-Mode Output pin (VOCM) provides a common-mode offset, which can be programmed to different values to accommodate pH sensor output ranges. For applications requiring a high-impedance, common mode, this option is also available. Two guard pins provide support for high parasitic impedance wiring. A user-controlled sensor diagnostic test is also available. This function tests the sensor for proper connection and functionality.

8.2 Functional Block Diagram

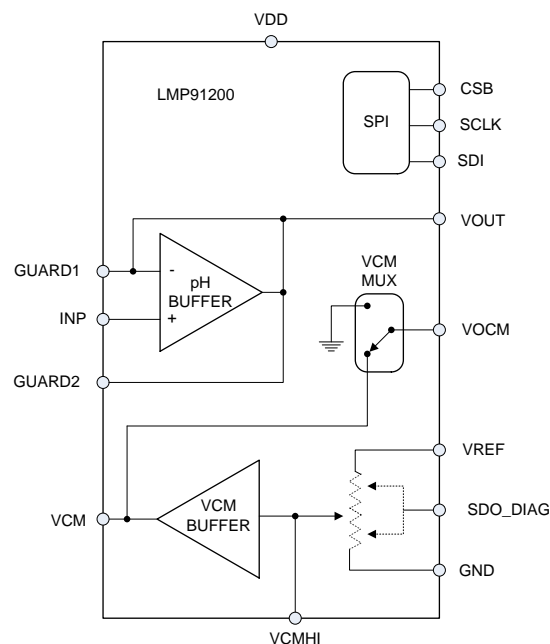

8.3 Feature Description

8.3.1 pH Buffer

The pH Buffer is a unity gain buffer with a input bias current in the range of tens fA at room temperature. Its very low bias current introduces a negligible error in the measurement of the pH. The pH buffer is provided with 2 guard pins (GUARD1, GUARD2) in order to minimize the leakage of the input current and to make easy the design of a guard ring.

8.3.2 Common-Mode Selector and VCM Buffer

The common-mode selector allows 7 different values of common-mode voltage to be set (from 1/8 VREF to 7/8 VREF with 1/8 VREF step) according to the applied voltage reference at VREF pin. Both buffered and unbuffered version of the set common-mode voltage are available respectively at VCM pin and VCMHI pin. A copy of the buffered version is present at VOVM pin in case of differential measurement.

8.3.3 Output Configuration

The output of the LMP91200 can be configured to support both differential and single ended ADCs. When measuring pH, the Output signal can be referred either to VCM or GND. The Output configuration is controlled through the SPI interface.

8.3.4 Diagnostic Feature

The diagnostic function allows for the detection and connection of the sensor. Further analysis of the response of the pH probe to the diagnostic stimulus allows one to estimate the aging of the pH probe. It is possible to slightly change ($\pm 5\%$ VREF) the common-mode voltage with the diagnostic function. If the sensor is present, it reacts. This reaction provides information on the status of the connection, the presence of the sensor, and the aging of the sensor. In fact, a typical symptom of the aging of a pH probe is the slow speed of the response. The response of an aging pH probe is shown by a decrease in the rising or falling response rate of the probe to a change in pH.

The procedure is enabled and disabled by SPI (refer to the [Table 2](#)). Until bit D6 is at a low logic level, VCM stays at the programmed voltage independently by the SDO_DIAG pin status. When bit D6 is tied at high logic level, on the first rising edge of SDO_DIAG, a positive pulse is generated. At the second positive rising edge of SDO_DIAG pin, the positive pulse ends. At the third positive rising edge of SDO_DIAG, a negative pulse is generated. At the fourth positive rising edge of the SDO_DIAG, the negative pulse ends and the routine is stopped and cannot restart until bit D6 is set again at 1.

8.4 Device Functional Modes

The LMP91200 supports two modes, Normal operation and Diagnostic mode. Normal operation is when the device is used to monitor pH levels. Diagnostic mode assess the quality of probe operation in addition to monitoring pH levels.

8.5 Programming

All the features of the LMP91200 (Mode of Operation, PGA Gain, Voltage reference, Diagnostic) are stored in a programming register. Data to be written into the control register is first loaded into the LMP91200 through the serial interface. The serial interface employs a 16-bit shift register. Data is loaded through the serial data input, SDI. Data passing through the shift register is output through the serial data output, SDO_DIAG. The serial clock, SCK controls the serial loading process. All 16 data bits are required to correctly program the LMP91200. The falling edge of CSB enables the shift register to receive data. The SCK signal must be high during the falling and rising edge of CSB. Each data bit is clocked into the shift register on the rising edge of SCLK. Data is transferred from the shift register to the holding register on the rising edge of CSB.

8.6 Register Maps

Table 1. Configuration Register

BIT	NAME	DESCRIPTION
D15	MEAS_MODE	0 pH measurement (default)
D14	Reserved	0 (default)
[D13:D12]	Reserved	00 (default)
D11	PGA	0 5 V/V (default) 1 10 V/V
[D10 :D8]	VCM	011 7/8 VREF 010 3/4 VREF 001 5/8 VREF 000 1/2 VREF (default) 100 1/2 VREF 101 3/8 VREF 110 1/4 VREF 111 1/8 VREF
D7	VOCM	0 VOCM (default) 1 GND
D6	DIAG_EN	0 DIAG pin disabled (default) 1 DIAG pin enabled
[D5 :D0]	RESERVED	RESERVED

9 Application and Implementation

NOTE

Information in the following applications sections is not part of the TI component specification, and TI does not warrant its accuracy or completeness. TI's customers are responsible for determining suitability of components for their purposes. Customers should validate and test their design implementation to confirm system functionality.

9.1 Application Information

9.1.1 Theory of pH Measurement

The pH electrode measurements are made by comparing the readings in a sample with the readings in standards whose pH has been defined (buffers). When a pH sensing electrode comes in contact with a sample, a potential develops across the sensing membrane surface and that membrane potential varies with pH. A reference electrode provides a second, unvarying potential to quantitatively compare the changes of the sensing membrane potential. These days, pH electrodes are composed of a sensing electrode with the reference electrode built into the same electrode body, and they are called combination electrodes. A high input impedance meter serves as the readout device and calculates the difference between the reference electrode and sensing electrode potentials in millivolts. The millivolts are then converted to pH units according to the Nernst equation.

Electrode behavior is described by the Nernst equation:

$$E = E_o + (2.3 RT/nF) \log aH^+$$

where

- E is the measured potential from the sensing electrode,
- E_o is related to the potential of the reference electrode,
- (2.3 RT/nF) is the Nernst factor,
- log aH⁺ is the pH, (aH⁺ = activity of Hydrogen ions).

(1)

2.3 RT/nF includes the Gas Law constant (R), Faraday's constant (F), the temperature in degrees Kelvin (T) and the stoichiometric number of ions involved in the process (n). For pH, where n = 1, the Nernst factor is 2.3 RT/F. Because R and F are constants, the factor and therefore electrode behavior is dependent on temperature. The Nernst Factor is equivalent to the electrode slope which is a measure of the electrode response to the ion being detected. When the temperature is 25°C, the theoretical Nernst slope is 59.16 mV/pH unit.

9.2 Typical Application

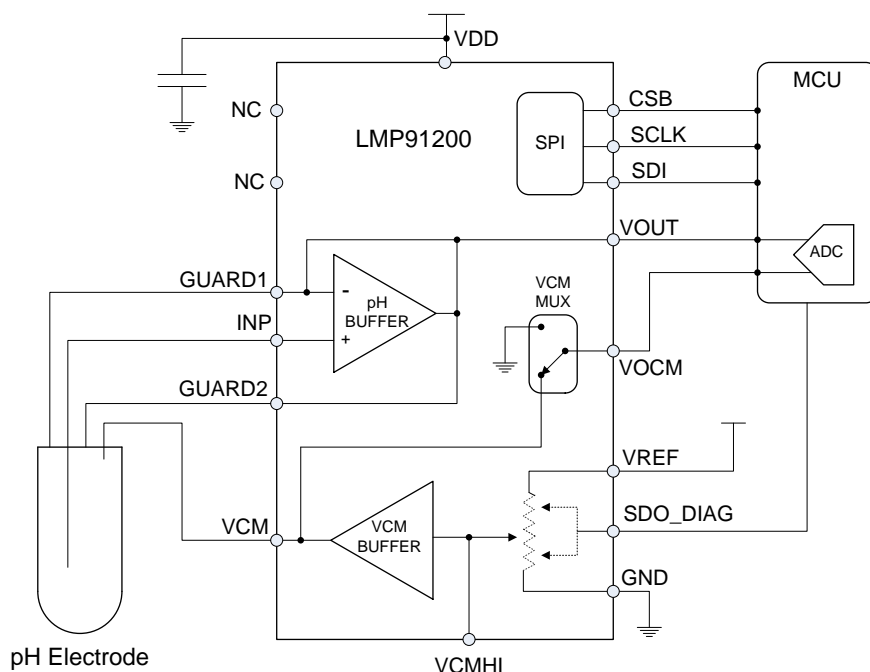

Figure 41. Typical Application

9.2.1 Design Requirements

9.2.1.1 pH Measurement

The output of a pH electrode ranges from 415 mV to -415 mV as the pH changes from 0 to 14 at 25°C. The output impedance of a pH electrode is extremely high, ranging from 10 MΩ to 1000 MΩ. The low input bias current of the LMP91200 allows the voltage error produced by the input bias current and electrode resistance to be minimal. For example, the output impedance of the pH electrode used is 10 MΩ, if an operational amplifier with 3 nA of I_{bias} is used, the error caused due to the input bias current of the amplifier and the source resistance of the pH electrode is 30 mV! This error can be greatly reduced to 1.25 μV by using the LMP91200.

The pH measurement with the LMP91200 is straightforward. The pH electrode must be connected between VCM pin and INP pin. The voltage at VCM pin represent the internal zero of the system, so the potential of the electrode (voltage at INP pin) will be referred to VCM voltage. The common-mode voltage can be set to well fit the input dynamic range of an external ADC connected between VOUT and VO_{CM} when the LMP91200 is configured with differential output. In Table 2 a typical configuration of the register of the LMP91200 with VCM set at 1/2 of VREF and differential output.

Table 2. Configuration Register: pH Measurement

BIT	NAME	DESCRIPTION
D15	MEAS_MODE	0 pH measurement
D14	Reserved	0
[D13:D12]	Reserved	00
D11	PGA	Set according to probe requirements
[D10 :D8]	VCM	000 1/2 VREF
D7	VO _{CM}	0 VO _{CM}
D6	DIAG_EN	0 DIAGNOSTIC disabled
[D5 :D0]	RESERVED	RESERVED

9.2.2 Detailed Design Procedure

The LMP91200 is configured to execute a pH measurement as described in the [pH Measurement](#) section and [Table 2](#). The design procedure consists of:

1. Determining the appropriate VCM level based on probe characteristics.
2. Determining the appropriate gain for the sensor signal based on the probe characteristics. Both VCM and the pH buffer gain should be selected to maximize the dynamic range of the probe signal relative to the full scale range of the ADC.
3. Selecting either GND reference or VCM for the VCM mux, according to the ADC input requirements.
4. Configuring the LMP91200 through the SPI port.

Refer to [Table 1](#) for the register configuration example, and [Figure 1](#) for the SPI interface format and timing example.

9.2.3 Application Curves

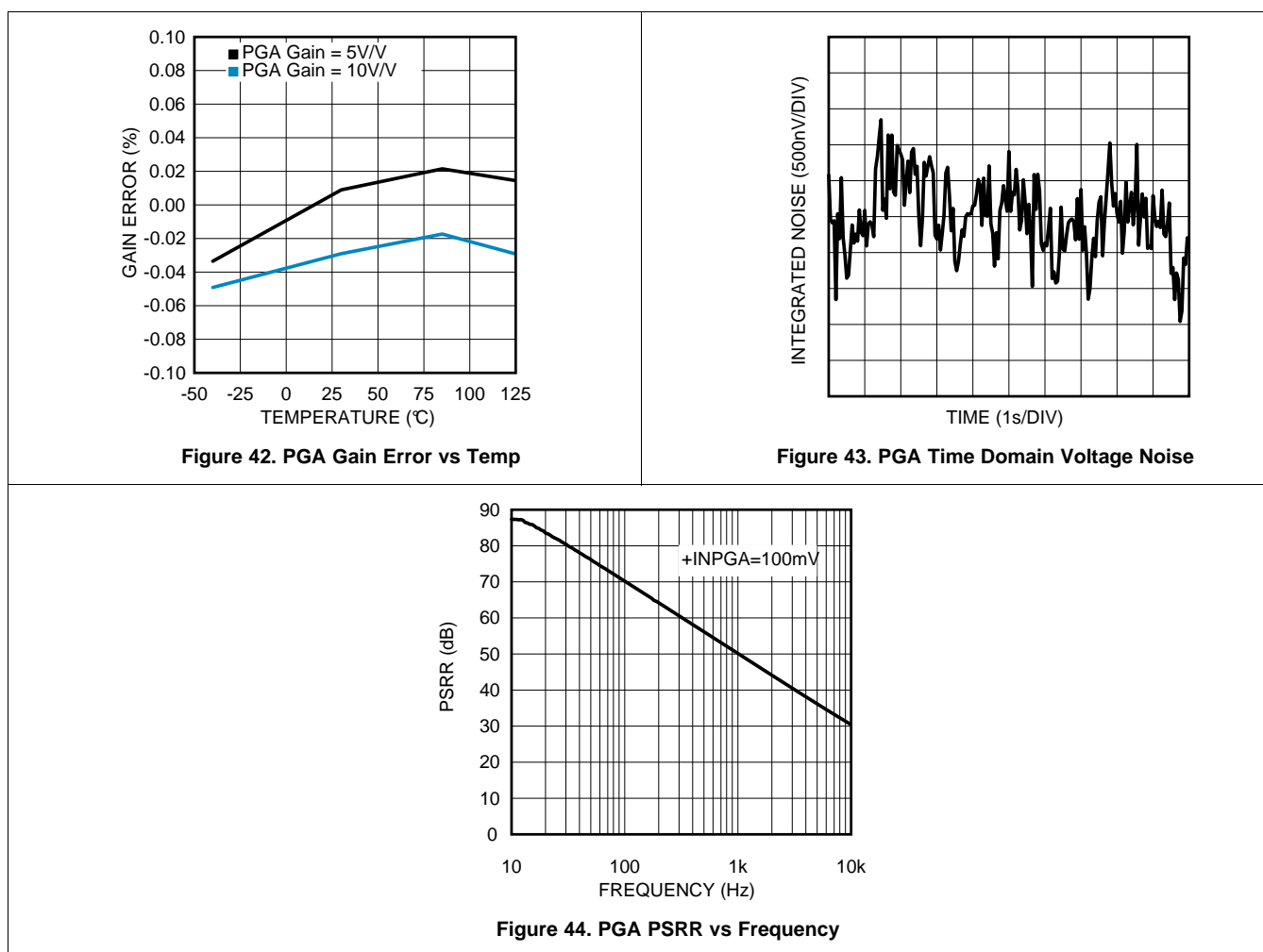

10 Power Supply Recommendations

VDD should be bypassed with 10- μ F, 1- μ F and 0.1- μ F capacitors, placed as close as possible to the LMP91200 VDD pin (pin 1). An LDO is recommended for the supply rail, but a DC-DC switcher may be used if sufficient filtering is used to attenuate the switching frequency components.

11 Layout

11.1 Layout Guidelines

Due to the high impedance of the pH Electrode in the pH measurement, careful circuit layout and assembly are required. Guarding techniques are highly recommended to reduce parasitic leakage current by isolating the input of the LMP91200 from large voltage gradients across the PCB. A guard is a low impedance conductor that surrounds an input line and its potential is raised to the voltage of the input line. The input pin should be fully guarded as shown in Figure 45. The guard traces should completely encircle the input connections. In addition, they should be located on both sides of the PCB and be connected together. The LMP91200 makes the guard ring easy to be implemented without any other external operational amplifier. The ring needs to be connected to the guard pins (GUARD1 and GUARD2), which are at the same potential as that of the INP pin. Solder mask should not cover the input and the guard area, including guard traces on either side of the PCB. Sockets are not recommended as they can be a significant leakage source. After assembly, a thorough cleaning using commercial solvent is necessary.

Figure 45 shows a typical guard ring circuit when the LMP91200 is interfaced to a pH probe through a triaxial cable/connector (usually referred to as *triax*). The signal conductor and the guard of the triax should be kept at the same potential. Therefore, the leakage current between them is practically zero. Because the triax has an extra layer of insulation and a second conducting sheath, it offers greater rejection of interference than coaxial cable or connector.

11.2 Layout Example

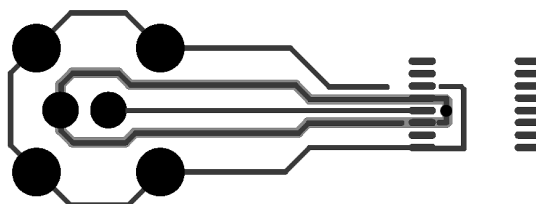

Figure 45. Circuit Board Guard Layout

12 Device and Documentation Support

12.1 Community Resources

The following links connect to TI community resources. Linked contents are provided "AS IS" by the respective contributors. They do not constitute TI specifications and do not necessarily reflect TI's views; see TI's [Terms of Use](#).

TI E2E™ Online Community *TI's Engineer-to-Engineer (E2E) Community*. Created to foster collaboration among engineers. At e2e.ti.com, you can ask questions, share knowledge, explore ideas and help solve problems with fellow engineers.

Design Support *TI's Design Support* Quickly find helpful E2E forums along with design support tools and contact information for technical support.

12.2 Trademarks

E2E is a trademark of Texas Instruments.

WEBENCH is a registered trademark of Texas Instruments.

All other trademarks are the property of their respective owners.

12.3 Electrostatic Discharge Caution



These devices have limited built-in ESD protection. The leads should be shorted together or the device placed in conductive foam during storage or handling to prevent electrostatic damage to the MOS gates.

12.4 Glossary

[SLYZ022](#) — *TI Glossary*.

This glossary lists and explains terms, acronyms, and definitions.

13 Mechanical, Packaging, and Orderable Information

The following pages include mechanical, packaging, and orderable information. This information is the most current data available for the designated devices. This data is subject to change without notice and revision of this document. For browser-based versions of this data sheet, refer to the left-hand navigation.

PACKAGING INFORMATION

Orderable Device	Status (1)	Package Type	Package Drawing	Pins	Package Qty	Eco Plan (2)	Lead/Ball Finish (6)	MSL Peak Temp (3)	Op Temp (°C)	Device Marking (4/5)	Samples
LMP91200MT/NOPB	NRND	TSSOP	PW	16	92	Green (RoHS & no Sb/Br)	CU SN	Level-3-260C-168 HR		LMP912 00MT	
LMP91200MTX/NOPB	NRND	TSSOP	PW	16	2500	Green (RoHS & no Sb/Br)	CU SN	Level-3-260C-168 HR		LMP912 00MT	

(1) The marketing status values are defined as follows:

ACTIVE: Product device recommended for new designs.

LIFEBUY: TI has announced that the device will be discontinued, and a lifetime-buy period is in effect.

NRND: Not recommended for new designs. Device is in production to support existing customers, but TI does not recommend using this part in a new design.

PREVIEW: Device has been announced but is not in production. Samples may or may not be available.

OBSOLETE: TI has discontinued the production of the device.

(2) Eco Plan - The planned eco-friendly classification: Pb-Free (RoHS), Pb-Free (RoHS Exempt), or Green (RoHS & no Sb/Br) - please check <http://www.ti.com/productcontent> for the latest availability information and additional product content details.

TBD: The Pb-Free/Green conversion plan has not been defined.

Pb-Free (RoHS): TI's terms "Lead-Free" or "Pb-Free" mean semiconductor products that are compatible with the current RoHS requirements for all 6 substances, including the requirement that lead not exceed 0.1% by weight in homogeneous materials. Where designed to be soldered at high temperatures, TI Pb-Free products are suitable for use in specified lead-free processes.

Pb-Free (RoHS Exempt): This component has a RoHS exemption for either 1) lead-based flip-chip solder bumps used between the die and package, or 2) lead-based die adhesive used between the die and leadframe. The component is otherwise considered Pb-Free (RoHS compatible) as defined above.

Green (RoHS & no Sb/Br): TI defines "Green" to mean Pb-Free (RoHS compatible), and free of Bromine (Br) and Antimony (Sb) based flame retardants (Br or Sb do not exceed 0.1% by weight in homogeneous material)

(3) MSL, Peak Temp. - The Moisture Sensitivity Level rating according to the JEDEC industry standard classifications, and peak solder temperature.

(4) There may be additional marking, which relates to the logo, the lot trace code information, or the environmental category on the device.

(5) Multiple Device Markings will be inside parentheses. Only one Device Marking contained in parentheses and separated by a "~" will appear on a device. If a line is indented then it is a continuation of the previous line and the two combined represent the entire Device Marking for that device.

(6) Lead/Ball Finish - Orderable Devices may have multiple material finish options. Finish options are separated by a vertical ruled line. Lead/Ball Finish values may wrap to two lines if the finish value exceeds the maximum column width.

Important Information and Disclaimer: The information provided on this page represents TI's knowledge and belief as of the date that it is provided. TI bases its knowledge and belief on information provided by third parties, and makes no representation or warranty as to the accuracy of such information. Efforts are underway to better integrate information from third parties. TI has taken and continues to take reasonable steps to provide representative and accurate information but may not have conducted destructive testing or chemical analysis on incoming materials and chemicals. TI and TI suppliers consider certain information to be proprietary, and thus CAS numbers and other limited information may not be available for release.

In no event shall TI's liability arising out of such information exceed the total purchase price of the TI part(s) at issue in this document sold by TI to Customer on an annual basis.

TAPE AND REEL INFORMATION



QUADRANT ASSIGNMENTS FOR PIN 1 ORIENTATION IN TAPE



*All dimensions are nominal

Device	Package Type	Package Drawing	Pins	SPQ	Reel Diameter (mm)	Reel Width W1 (mm)	A0 (mm)	B0 (mm)	K0 (mm)	P1 (mm)	W (mm)	Pin1 Quadrant
LMP91200MTX/NOPB	TSSOP	PW	16	2500	330.0	12.4	6.95	5.6	1.6	8.0	12.0	Q1

TAPE AND REEL BOX DIMENSIONS



*All dimensions are nominal

Device	Package Type	Package Drawing	Pins	SPQ	Length (mm)	Width (mm)	Height (mm)
LMP91200MTX/NOPB	TSSOP	PW	16	2500	367.0	367.0	35.0

PW (R-PDSO-G16)

PLASTIC SMALL OUTLINE

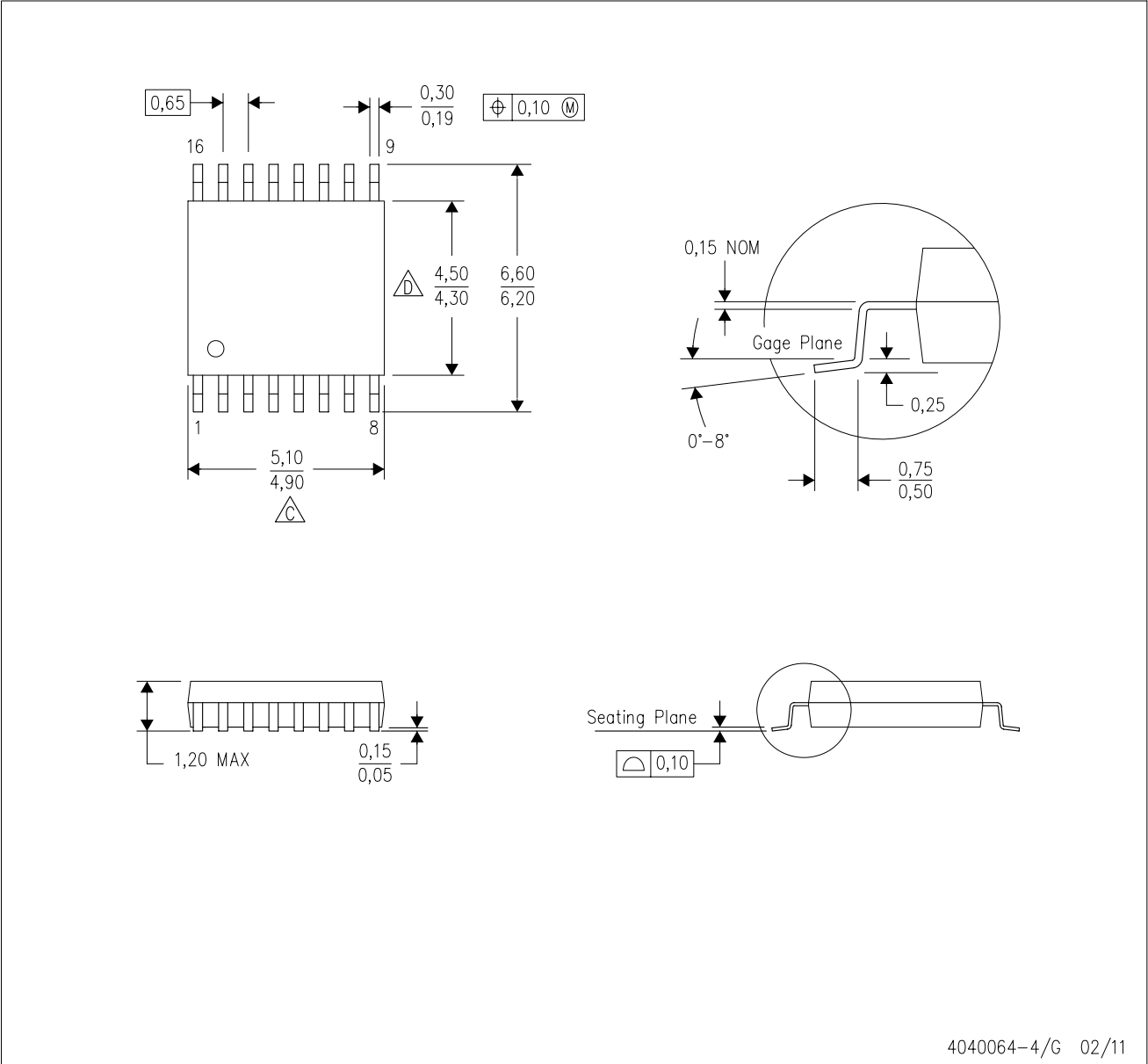

- NOTES:
- A. All linear dimensions are in millimeters. Dimensioning and tolerancing per ASME Y14.5M-1994.
 - B. This drawing is subject to change without notice.
 - C. Body length does not include mold flash, protrusions, or gate burrs. Mold flash, protrusions, or gate burrs shall not exceed 0,15 each side.
 - D. Body width does not include interlead flash. Interlead flash shall not exceed 0,25 each side.
 - E. Falls within JEDEC MO-153

IMPORTANT NOTICE

Texas Instruments Incorporated and its subsidiaries (TI) reserve the right to make corrections, enhancements, improvements and other changes to its semiconductor products and services per JESD46, latest issue, and to discontinue any product or service per JESD48, latest issue. Buyers should obtain the latest relevant information before placing orders and should verify that such information is current and complete. All semiconductor products (also referred to herein as "components") are sold subject to TI's terms and conditions of sale supplied at the time of order acknowledgment.

TI warrants performance of its components to the specifications applicable at the time of sale, in accordance with the warranty in TI's terms and conditions of sale of semiconductor products. Testing and other quality control techniques are used to the extent TI deems necessary to support this warranty. Except where mandated by applicable law, testing of all parameters of each component is not necessarily performed.

TI assumes no liability for applications assistance or the design of Buyers' products. Buyers are responsible for their products and applications using TI components. To minimize the risks associated with Buyers' products and applications, Buyers should provide adequate design and operating safeguards.

TI does not warrant or represent that any license, either express or implied, is granted under any patent right, copyright, mask work right, or other intellectual property right relating to any combination, machine, or process in which TI components or services are used. Information published by TI regarding third-party products or services does not constitute a license to use such products or services or a warranty or endorsement thereof. Use of such information may require a license from a third party under the patents or other intellectual property of the third party, or a license from TI under the patents or other intellectual property of TI.

Reproduction of significant portions of TI information in TI data books or data sheets is permissible only if reproduction is without alteration and is accompanied by all associated warranties, conditions, limitations, and notices. TI is not responsible or liable for such altered documentation. Information of third parties may be subject to additional restrictions.

Resale of TI components or services with statements different from or beyond the parameters stated by TI for that component or service voids all express and any implied warranties for the associated TI component or service and is an unfair and deceptive business practice. TI is not responsible or liable for any such statements.

Buyer acknowledges and agrees that it is solely responsible for compliance with all legal, regulatory and safety-related requirements concerning its products, and any use of TI components in its applications, notwithstanding any applications-related information or support that may be provided by TI. Buyer represents and agrees that it has all the necessary expertise to create and implement safeguards which anticipate dangerous consequences of failures, monitor failures and their consequences, lessen the likelihood of failures that might cause harm and take appropriate remedial actions. Buyer will fully indemnify TI and its representatives against any damages arising out of the use of any TI components in safety-critical applications.

In some cases, TI components may be promoted specifically to facilitate safety-related applications. With such components, TI's goal is to help enable customers to design and create their own end-product solutions that meet applicable functional safety standards and requirements. Nonetheless, such components are subject to these terms.

No TI components are authorized for use in FDA Class III (or similar life-critical medical equipment) unless authorized officers of the parties have executed a special agreement specifically governing such use.

Only those TI components which TI has specifically designated as military grade or "enhanced plastic" are designed and intended for use in military/aerospace applications or environments. Buyer acknowledges and agrees that any military or aerospace use of TI components which have **not** been so designated is solely at the Buyer's risk, and that Buyer is solely responsible for compliance with all legal and regulatory requirements in connection with such use.

TI has specifically designated certain components as meeting ISO/TS16949 requirements, mainly for automotive use. In any case of use of non-designated products, TI will not be responsible for any failure to meet ISO/TS16949.

Products

Audio	www.ti.com/audio
Amplifiers	amplifier.ti.com
Data Converters	dataconverter.ti.com
DLP® Products	www.dlp.com
DSP	dsp.ti.com
Clocks and Timers	www.ti.com/clocks
Interface	interface.ti.com
Logic	logic.ti.com
Power Mgmt	power.ti.com
Microcontrollers	microcontroller.ti.com
RFID	www.ti-rfid.com
OMAP Applications Processors	www.ti.com/omap
Wireless Connectivity	www.ti.com/wirelessconnectivity

Applications

Automotive and Transportation	www.ti.com/automotive
Communications and Telecom	www.ti.com/communications
Computers and Peripherals	www.ti.com/computers
Consumer Electronics	www.ti.com/consumer-apps
Energy and Lighting	www.ti.com/energy
Industrial	www.ti.com/industrial
Medical	www.ti.com/medical
Security	www.ti.com/security
Space, Avionics and Defense	www.ti.com/space-avionics-defense
Video and Imaging	www.ti.com/video

TI E2E Community

e2e.ti.com