

LMX2502/LMX2512 PLLatinum™ Frequency Synthesizer System with Integrated VCO

Check for Samples: [LMX2502](#), [LMX2512](#)

FEATURES

- **Small Size**
 - 5.0 mm X 5.0 mm X 0.75 mm 28-Pin WQFN Package
- **RF Synthesizer System**
 - Integrated RF VCO
 - Integrated Loop Filter
 - Low Spurious, Low Phase Noise Fractional-N RF PLL Based on 11-Bit Delta Sigma Modulator
 - 10 kHz Frequency Resolution
- **IF Synthesizer System**
 - Integer-N IF PLL
 - Programmable Charge Pump Current Levels
 - Programmable Frequency
- **Supports Various Reference Frequencies**
 - 19.20/19.68 MHz
- **Fast Lock Time: 500 μ s**
- **Low Current Consumption**
 - 17 mA at 2.8 V
- **2.7 V to 3.3 V Operation**
- **Digital Filtered Lock Detect Output**
- **Hardware and Software Power Down Control**

APPLICATIONS

- **Korean PCS CDMA Systems**
- **Korean Cellular CDMA Systems**

DESCRIPTION

LMX2502 and LMX2512 are highly integrated, high performance, low power frequency synthesizer systems optimized for Korean PCS and Korean Cellular CDMA (1xRTT, IS-95) mobile handsets. Using a proprietary digital phase locked loop technique, LMX2502 and LMX2512 generate very stable, low noise local oscillator signals for up and down conversion in wireless communications devices.

LMX2502 and LMX2512 include a voltage controlled oscillator (VCO), a loop filter, and a fractional-N RF PLL based on a delta sigma modulator. In concert these blocks form a closed loop RF synthesizer system. LMX2502 supports the Korean PCS band and LMX2512 supports the Korean Cellular band.

LMX2502 and LMX2512 include an Integer-N IF PLL also. For more flexible loop filter designs, the IF PLL includes a 4-level programmable charge pump. Together with an external VCO and loop filter, LMX2502 and LMX2512 make a complete closed loop IF synthesizer system.

Serial data is transferred to the device via a three-wire MICROWIRE interface (DATA, LE, CLK).

Operating supply voltage ranges from 2.7 V to 3.3 V. LMX2502 and LMX2512 feature low current consumption: 17 mA at 2.8 V.

LMX2502 and LMX2512 are available in a 28-pin WQFN package.



Please be aware that an important notice concerning availability, standard warranty, and use in critical applications of Texas Instruments semiconductor products and disclaimers thereto appears at the end of this data sheet.

All trademarks are the property of their respective owners.

Functional Block Diagram

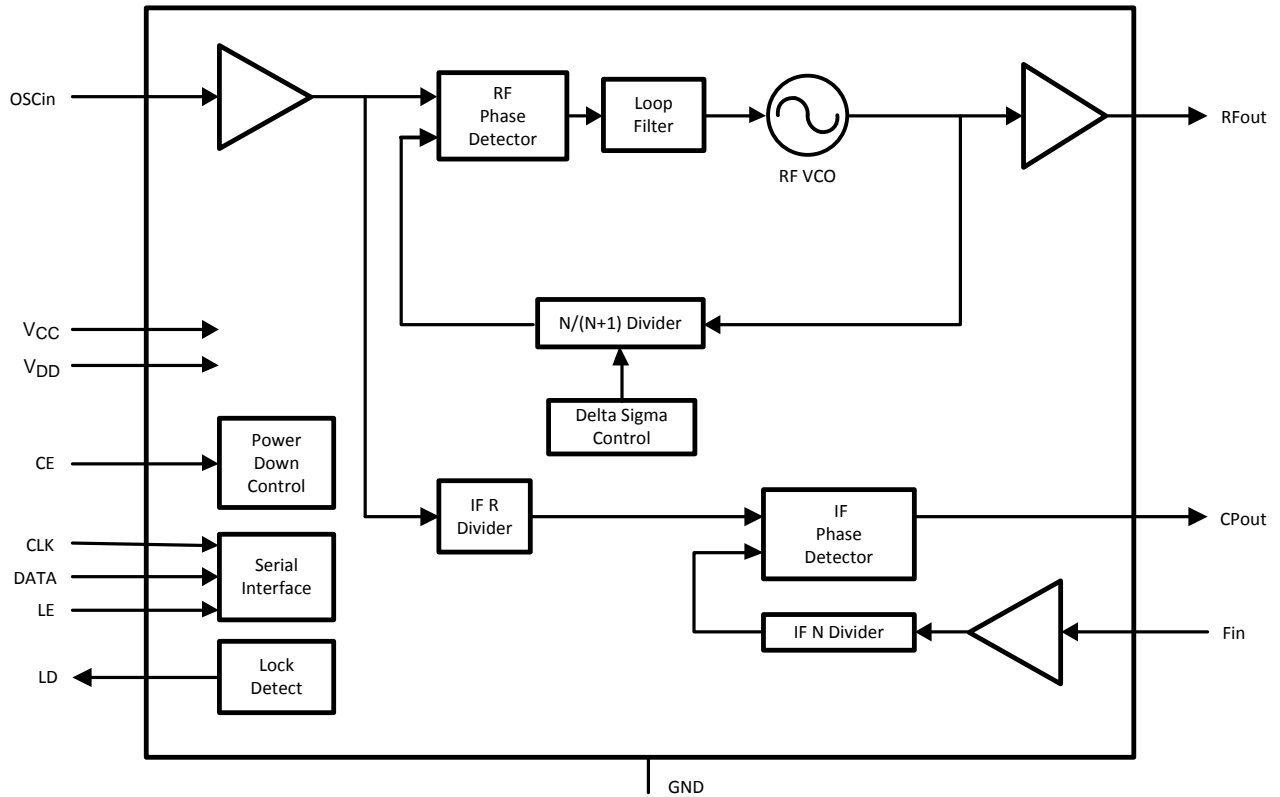

Connection Diagram

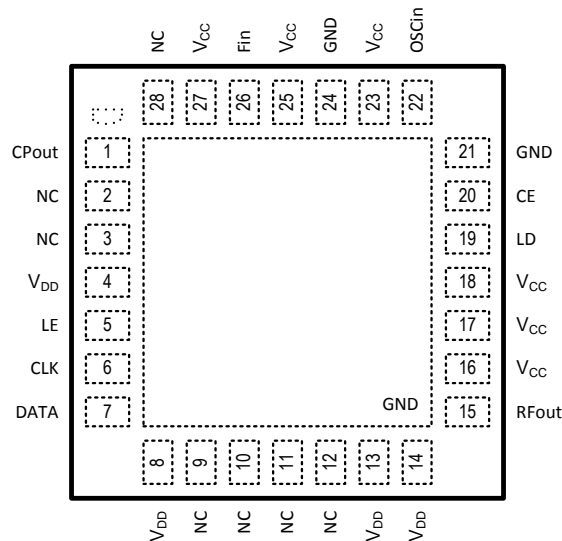

NOTE: Analog ground connected through exposed die attached pad.

Figure 1. 28-Pin WQFN (NJB) Package

PIN DESCRIPTIONS

Pin Number	Name	I/O	Description
1	CPout	O	IF PLL charge pump output
2	NC	–	Do not connect to any node on the printed circuit board.
3	NC	–	Do not connect to any node on the printed circuit board.
4	V _{DD}	–	Supply voltage for IF analog circuitry
5	LE	I	MICROWIRE Latch Enable
6	CLK	I	MICROWIRE Clock
7	DATA	I	MICROWIRE Data
8	V _{DD}	–	Supply voltage for VCO
9	NC	–	Do not connect to any node on the printed circuit board.
10	NC	–	Do not connect to any node on the printed circuit board.
11	NC	–	Do not connect to any node on the printed circuit board.
12	NC	–	Do not connect to any node on the printed circuit board.
13	V _{DD}	–	Supply voltage for VCO
14	V _{DD}	–	Supply voltage for VCO output buffer
15	RFout	O	Buffered VCO output
16	V _{CC}	–	Supply voltage for RF prescaler
17	V _{CC}	–	Supply voltage for charge pump
18	V _{CC}	–	Supply voltage for RF digital circuitry
19	LD	O	Lock Detect
20	CE	I	Chip Enable control pin
21	GND	–	Ground for digital circuitry
22	OSCI _{in}	I	Reference frequency input
23	V _{CC}	–	Supply voltage for reference input buffer
24	GND	–	Ground for digital circuitry
25	V _{CC}	–	Supply voltage for IF digital circuitry
26	Fin	I	IF buffer/prescaler input
27	V _{CC}	–	Supply voltage for IF buffer/prescaler
28	NC	–	Do not connect to any node on the printed circuit board.



These devices have limited built-in ESD protection. The leads should be shorted together or the device placed in conductive foam during storage or handling to prevent electrostatic damage to the MOS gates.

ABSOLUTE MAXIMUM RATINGS (1)(2)(3)(4)

Parameter	Symbol	Ratings	Units
Supply Voltage	V _{CC} , V _{DD}	-0.3 to 3.6	V
Voltage on any pin to GND	V _I	-0.3 to V _{CC} +0.3	V
		-0.3 to V _{DD} +0.3	V
Storage Temperature Range	T _{STG}	-65 to 150	°C

- (1) Absolute Maximum Ratings indicate limits beyond which damage to the device may occur. Recommended Operating Conditions indicate conditions for which the device is intended to be functional, but do not ensure specific performance limits. For ensured specifications and test conditions, refer to the Electrical Characteristics section. The ensured specifications apply only for the conditions listed.
- (2) This device is a high performance RF integrated circuit with an ESD rating < 2 kV and is ESD sensitive. Handling and assembly of this device should be done at ESD protected work stations.
- (3) GND = 0 V.
- (4) If Military/Aerospace specified devices are required, please contact the Texas Instruments Sales Office/Distributors for availability and specifications.

RECOMMENDED OPERATING CONDITIONS

Parameter	Symbol	Min	Typ	Max	Units
Ambient Temperature	T _A	-30	25	85	°C
Supply Voltage (to GND)	V _{CC} , V _{DD}	2.7		3.3	V

ELECTRICAL CHARACTERISTICS

(V_{CC} = V_{DD} = 2.8 V, T_A = 25 °C; unless otherwise noted)

Symbol	Parameter	Condition	Min	Typ	Max	Units
I_{CC} PARAMETERS						
I _{CC} + I _{DD}	Total Supply Current	OB_CRL [1:0] = 00		17	19	mA
(I _{CC} + I _{DD}) _{RF}	RF PLL Total Supply Current	OB_CRL [1:0] = 00		16	18	mA
I _{PD}	Power Down Current (1)	CE = LOW or RF_EN = 0 IF_EN = 0			20	µA
REFERENCE OSCILLATOR PARAMETERS						
f _{OSCin}	Reference Oscillator Input Frequency (2)	19.20 MHz and 19.68 MHz are supported	19.20		19.68	MHz
V _{OSCin}	Reference Oscillator Input Sensitivity			0.2	V _{CC}	Vp-p

- (1) In power down mode, set DATA, CLK, and LE pins to 0 V (GND).
- (2) The reference frequency must also be programmed using the OSC_FREQ control bit. For other reference frequencies, please contact Texas Instruments.

ELECTRICAL CHARACTERISTICS (continued)
 $(V_{CC} = V_{DD} = 2.8\text{ V}, T_A = 25\text{ }^\circ\text{C}; \text{ unless otherwise noted})$

Symbol	Parameter	Condition	Min	Typ	Max	Units	
RF VCO							
f_{RFout}	Frequency Range (3)	LMX2502LQ1635	RF VCO	1619.62		1649.62	MHz
		LMX2512LQ0967		954.42		979.35	MHz
		LMX2512LQ1065		1052.64		1077.57	MHz
P_{RFout}	RF Output Power		OB_CRL [1:0] = 11	-2	1	4	dBm
			OB_CRL [1:0] = 10	-5	-2	1	dBm
			OB_CRL [1:0] = 01	-7	-4	-1	dBm
			OB_CRL [1:0] = 00	-9	-6	-3	dBm
	Lock Time (4)	LMX2502LQ1635	30 MHz Band for RF PLL		500	800	μs
		LMX2512LQ0967	25 MHz Band for RF PLL		500	800	μs
		LMX2512LQ1065	25 MHz Band for RF PLL		500	800	μs
	Reference Spurs				-75	dBc	
	RMS Phase Error	RF PLL in all band		1.3		degrees	
$L(f)_{RFout}$	Phase Noise	LMX2502LQ1635	@ 100 kHz offset		-113	-112	dBc/Hz
			@ 1.25 MHz offset		-138	-136	dBc/Hz
		LMX2512LQ0967	@ 100 kHz offset		-117	-115	dBc/Hz
			@ 900 kHz offset		-139	-138	dBc/Hz
		LMX2512LQ1065	@ 100 kHz offset		-117	-115	dBc/Hz
			@ 900 kHz offset		-139	-138	dBc/Hz
	2nd Harmonic Suppression				-25	dBc	
	3rd Harmonic Suppression				-20	dBc	
IF PLL							
f_{Fin}	Operating Frequency (5)	LMX2502LQ1635	IF_FREQ [1:0] = 10, Default Value		440.76		MHz
		LMX2512LQ0967	IF_FREQ [1:0] = 00, Default Value		170.76		MHz
		LMX2512LQ1065	IF_FREQ [1:0] = 01, Default Value		367.20		MHz
P_{Fin}	IF Input Sensitivity		-10		0	dBm	
$f_{\phi IF}$	Phase Detector Frequency			120		kHz	
I_{CPout}	Charge Pump Current		IF_CUR [1:0] = 00		100		μA
			IF_CUR [1:0] = 01		200		μA
			IF_CUR [1:0] = 10		300		μA
			IF_CUR [1:0] = 11		800		μA

(3) For other frequency ranges, please contact Texas Instruments.

(4) Lock time is defined as the time difference between the beginning of the frequency transition and the point at which the frequency remains within +/- 1 kHz of the final frequency.

(5) Frequencies other than the default value can be programmed using Words R4 and R5. See [Programming Description](#) for details.

ELECTRICAL CHARACTERISTICS (continued)

($V_{CC} = V_{DD} = 2.8\text{ V}$, $T_A = 25\text{ }^\circ\text{C}$; unless otherwise noted)

Symbol	Parameter	Condition	Min	Typ	Max	Units
DIGITAL INTERFACE (DATA, CLK, LE, LD, CE)						
V_{IH}	High-Level Input Voltage		$0.8 V_{DD}$		V_{DD}	V
			$0.8 V_{CC}$		V_{CC}	V
V_{IL}	Low-Level Input Voltage		0		$0.2 V_{DD}$	V
			0		$0.2 V_{CC}$	V
I_{IH}	High-Level Input Current		-10		10	μA
I_{IL}	Low-Level Input Current		-10		10	μA
	Input Capacitance			3		pF
V_{OH}	High-Level Output Voltage		$0.9 V_{DD}$			V
			$0.9 V_{CC}$			V
V_{OL}	Low-Level Output Voltage				$0.1 V_{DD}$	V
					$0.1 V_{CC}$	V
	Output Capacitance				5	pF
MICROWIRE INTERFACE TIMING						
t_{CS}	Data to Clock Set Up Time		50	-	-	ns
t_{CH}	Data to Clock Hold Time		10	-	-	ns
t_{CWH}	Clock Pulse Width HIGH		50	-	-	ns
t_{CWL}	Clock Pulse Width LOW		50	-	-	ns
t_{ES}	Clock to Latch Enable Set Up Time		50	-	-	ns
t_{EW}	Latch Enable Pulse Width		50	-	-	ns

Microwire Interface Timing Diagram

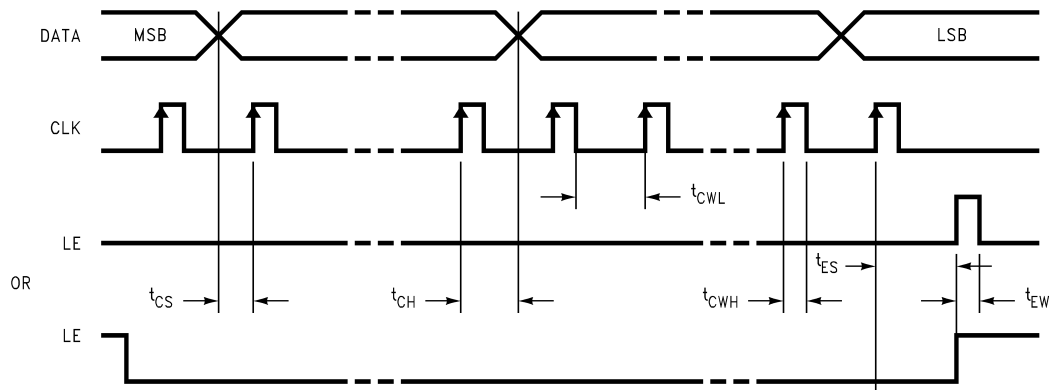

FUNCTIONAL DESCRIPTION

GENERAL DESCRIPTION

LMX2502/12 is a highly integrated frequency synthesizer system that generates LO signals for PCS and Cellular CDMA applications. These devices include all the functional blocks of a PLL, RF VCO, prescaler, RF phase detector, and loop filter. The need for external components is limited to a few passive elements for matching the output impedance and bypass elements for power line stabilization.

In addition to the RF circuitry, the IC also includes IF frequency dividers, and an IF phase detector to complete the IF synthesis with the external VCO and the loop filter. [Table 1](#) summarizes the counter values used to generate the default IF frequencies.

Using a low spurious fractional-N synthesizer based on a delta sigma modulator, the circuit can support 10 kHz channel spacing for PCS and Cellular CDMA systems.

The fractional-N synthesizer enables faster lock time, which reduces power consumption and system set-up time. Additionally, the loop filter occupies a smaller area as opposed to the integer-N architecture. This allows the loop filter to be embedded into the circuit, minimizing the external noise coupling and total form factor. The delta sigma architecture delivers very low spurious, which can be a significant problem for other PLL solutions.

The circuit also supports commonly used reference frequencies of 19.20 MHz and 19.68 MHz.

FREQUENCY GENERATION

RF-PLL Section

The divide ratio can be calculated using the following equation:

LMX2502 – PCS CDMA:

$$f_{VCO} = \{8 \times RF_B + RF_A + (RF_FN / f_{OSC}) \times 10^4\} \times f_{OSC} \text{ where } (RF_A < RF_B)$$

LMX2512 – Cellular CDMA:

$$f_{VCO} = \{6 \times RF_B + RF_A + (RF_FN / f_{OSC}) \times 10^4\} \times f_{OSC} \text{ where } (RF_A < RF_B)$$

where

- f_{VCO} : Output frequency of voltage controlled oscillator (VCO)
- RF_B : Preset divide ratio of binary 4-bit programmable counter ($2 \leq RF_B \leq 15$)
- RF_A : Preset divide ratio of binary 3-bit swallow counter ($0 \leq RF_A \leq 7$ for LMX2502 or $0 \leq RF_A \leq 5$ for LMX2512)
- RF_FN : Preset numerator of binary 11-bit modulus counter ($0 \leq RF_FN < 1920$ for $f_{OSC} = 19.20$ MHz or $0 \leq RF_FN < 1968$ for $f_{OSC} = 19.68$ MHz)
- f_{OSC} : Reference oscillator frequency

IF-PLL Section

$$f_{VCO} = \{16 \times IF_B + IF_A\} \times f_{OSC} / IF_R \text{ where } (IF_A < IF_B)$$

where

- f_{VCO} : Output frequency of the voltage controlled oscillator (VCO)
- IF_B : Preset divide ratio of the binary 9-bit programmable counter ($1 \leq IF_B \leq 511$)
- IF_A : Preset divide ratio of the binary 4-bit swallow counter ($0 \leq IF_A \leq 15$)
- f_{OSC} : Reference oscillator frequency
- IF_R : Preset divide ratio of the binary 9-bit programmable reference counter ($2 \leq IF_R \leq 511$)

From the above equation, the LMX2502/12 generates the fixed IF frequencies as summarized in [Table 1](#).

Table 1. IF Frequencies

Device Type	F _{VCO} (MHz)	IF_B	IF_A	f _{osc} /IF_R (kHz)
LMX2502LQ1635	440.76	229	9	120
LMX2512LQ0967	170.67	88	15	120
LMX2512LQ1065	367.20	191	4	120

VCO FREQUENCY TUNING

The center frequency of the RF VCO is determined by the resonant frequency of the tank circuit. This tank circuit is implemented on-chip and requires no external inductor. The LMX2502/12 actively tunes the tank circuit to the required frequency with the built-in tracking algorithm.

BANDWIDTH CONTROL AND FREQUENCY LOCK

During the frequency acquisition period, the loop bandwidth is significantly extended to achieve frequency lock. Once frequency lock occurs, the PLL will return to a steady state condition with the loop bandwidth set to its nominal value. The transition between acquisition and lock modes occurs seamlessly and extremely fast, thereby, meeting the stringent requirements associated with lock time and phase noise. Several controls (BW_DUR, BW_CRL, and BW_EN) are used to optimize the lock time performance.

SPURIOUS REDUCTION

To improve the spurious performance of the device one of two types of spurious reduction schemes can be selected:

- A continuous optimization scheme, which tracks the environmental and voltage variations, giving the best spurious performance over changing conditions
- A one time optimization scheme, which sets the internal compensation values only when the PLL goes into a locked state.

The spurious reduction can also be disabled, but it is recommended that the continuous optimization mode be used for normal operation.

POWER DOWN MODE

The LMX2502 and LMX2512 include a power down mode to reduce the power consumption. The LMX2502/12 enters into the power down mode either by taking the CE pin LOW or by setting the power down bits in Register R1. [Table 2](#) summarizes the power down function. If CE is set LOW, the circuit is powered down regardless of the register values. When CE is HIGH, the IF and RF circuitry are individually powered down by setting the register bits.

Table 2. Power Down Configuration⁽¹⁾

CE Pin	RF_EN	IF_EN	RF Circuitry	IF Circuitry
0	X	X	OFF	OFF
1	0	0	OFF	OFF
1	0	1	OFF	ON
1	1	0	ON	OFF
1	1	1	ON	ON

(1) X = Don't care.

LOCK DETECT

The LD output can be used to indicate the lock status of the RF PLL. Bit 21 in Register R0 determines the signal that appears on the LD pin. When the RF PLL is not locked, the LD pin remains LOW. After obtaining phase lock, the LD pin will have a logical HIGH level. The output can also be programmed to be ground at all times.

Table 3. Lock Detect Modes

LD Bit	Mode
0	Disable (GND)
1	Enable

Table 4. Lock Detect Logic

RF PLL Section	LD Output
Locked	HIGH
Not Locked	LOW

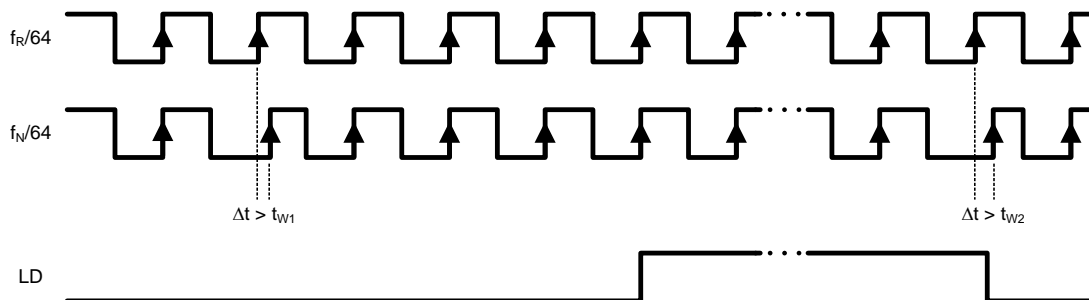

- (1) LD output becomes LOW when the phase error is larger than t_{W2} .
- (2) LD output becomes HIGH when the phase error is less than t_{W1} for four or more consecutive cycles.
- (3) Phase Error is measured on leading edge. Only errors greater than t_{W1} and t_{W2} are labeled.
- (4) t_{W1} and t_{W2} are equal to 10 ns.
- (5) The lock detect comparison occurs with every 64th cycle of f_R and f_N .

Figure 2. Lock Detect Timing Diagram Waveform

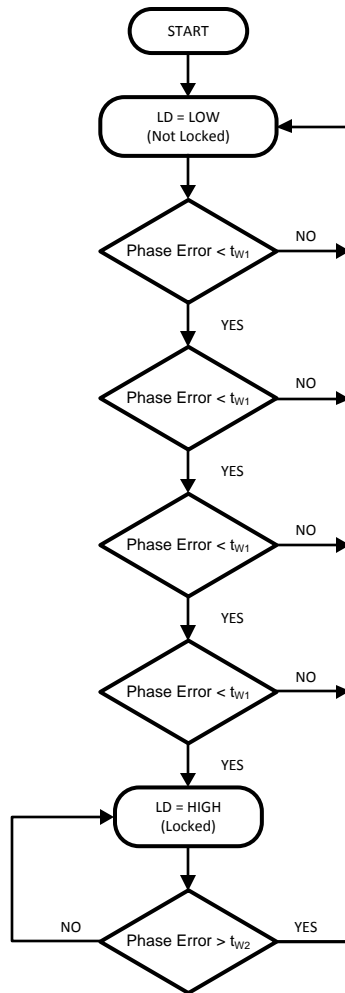

Figure 3. Lock Detect Flow Diagram

MICROWIRE INTERFACE

The programmable register set is accessed via the MICROWIRE serial interface. The interface comprises three signal pins: CLK, DATA, and LE (Latch Enable). Serial data (DATA) is clocked into the 24-bit shift register on the rising edge of the clock (CLK). The last bits decode the internal control register address. When the latch enable (LE) transitions from LOW to HIGH, data stored in the shift registers is loaded into the corresponding control register.

Programming Description

GENERAL PROGRAMMING INFORMATION

The serial interface has a 24-bit shift register to store the incoming data bits temporarily. The incoming data is loaded into the shift register from MSB to LSB. The data is shifted at the rising edge of the clock signal. When the latch enable signal transitions from LOW to HIGH, the data stored in the shift register is transferred to the proper register depending on the address bit settings. The selection of the particular register is determined by the address bits equal to the binary representation of the number of the control register.

At initial start-up, the MICROWIRE loading requires 4 default words (registers R3, loaded first, to R0, loaded last). After the device has been initially programmed, the RF VCO frequency can be changed using a single register (R0). If an IF frequency other than the default value for the device is desired the SPI_DEF bit should be set to 0, the desired values for IF_A, IF_B, and IF_R entered and words R6 to R0 should be sent.

The control register content map describes how the bits within each control register are allocated to the specific control functions.

Table 5. COMPLETE REGISTER MAP

Register	SHIFT REGISTER BIT LOCATION																						LSB			
	23	22	21	20	19	18	17	16	15	14	13	12	11	10	9	8	7	6	5	4	3	2	1	0		
R0 (Default)	SPI_DEF	RF_SEL	RF_LD	0	RF_B [3:0]			RF_A [2:0]			RF_FN [10:0]											0	0			
R1 (Default)	IF_FREQ [1:0]		OS_C_FREQ	1	0	0	0	0	0	0	0	SPUR_RDT [1:0]	0	0	1	0	1	OB_CRL [1:0]		RF_EN	IF_EN	0	1			
R2 (Default)	IF_CUR[1:0]		0	0	1	0	0	1	1	1	0	1	1	0	1	0	1	0	0	1	0	1	0			
R3 (Default)	BW_DUR [1:0]		BW_CRL [1:0]		BW_EN		1	0	1	1	1	1	0	1	0	0	0	1	1	0	VCO_CUR [1:0]		0	1	1	
R4	0	0	0	1	0	0	0	IF_A [3:0]			IF_B [8:0]								0	1	1	1				
R5	0	0	1	1	0	0	0	0	1	0	IF_R [8:0]								0	1	1	1	1			
R6	1	0	0	0	0	0	0	0	0	0	0	0	0	0	0	0	0	0	0	0	0	1	1	1	1	1

NOTE: **Bold** numbers represent the address bits.

R0 REGISTER

The R0 register address bits (R0 [1:0]) are “00”.

The SPI_DEF bit selects between using the default IF counter values and user programmable values. The use of the default counter values requires that only words R0 to R3 (registers R3, loaded first, to R0, loaded last) be sent after initial power up.

The RF_LD bit activates the lock detect output of the LD pin (pin 19). The lock detect mode shows the lock status of the RF PLL. The waveform of the lock detect mode is shown in [Figure 2](#), in the [FUNCTIONAL DESCRIPTION](#) section on [LOCK DETECT](#).

The RF N counter consists of the 4-bit programmable counter (RF_B counter), the 3-bit swallow counter (RF_A counter) and the 11-bit delta sigma modulator (RF_FN counter). The equations for calculating the counter values are presented below.

Table 6. R0 REGISTER

Register	SHIFT REGISTER BIT LOCATION																						LSB	
	23	22	21	20	19	18	17	16	15	14	13	12	11	10	9	8	7	6	5	4	3	2	1	0
	Data Field																						Address Field	
R0 (Default)	SPI_DEF	RF_SEL	RF_LD	0	RF_B [3:0]			RF_A [2:0]			RF_FN [10:0]											0	0	

Table 7.

Name	Functions
SPI_DEF	Default Register Selection 0 = OFF (Use values set in R0 to R6) 1 = ON (Use default values set in R0 to R3)
RF_SEL	RF VCO Selection 0 = LMX2512 1 = LMX2502
RF_LD	RF Lock Detect 0 = Hard zero (GND) 1 = Lock detect
RF_B [3:0]	RF_B Counter 4-bit programmable counter $2 \leq RF_B \leq 15$
RF_A [2:0]	RF_A Counter 3-bit swallow counter $0 \leq RF_A \leq 7$ for LMX2502 $0 \leq RF_A \leq 5$ for LMX2512
RF_FN [10:0]	RF Fractional Numerator Counter 11-bit programmable counter $0 \leq RF_FN < 1920$ for $f_{OSC} = 19.20$ MHz $0 \leq RF_FN < 1968$ for $f_{OSC} = 19.68$ MHz

RF N Counter Setting:

Counter Name	Symbol	Function
Modulus Counter	RF_FN	RF N Divider $N = \text{Prescaler} \times RF_B + RF_A + (RF_FN / f_{OSC}) \times 10^4$
Programmable Counter	RF_B	
Swallow Counter	RF_A	

Pulse Swallow Function:

$$f_{VCO} = \{\text{Prescaler} \times RF_B + RF_A + (RF_FN / f_{OSC}) \times 10^4\} \times f_{OSC} \text{ where } (RF_A < RF_B)$$

where

- f_{VCO} : Output frequency of voltage controlled oscillator (VCO)

Prescaler Values:

Device Type	RF Prescaler
LMX2502	8
LMX2512	6

RF_B: Preset divide ratio of binary 4-bit programmable counter ($2 \leq RF_B \leq 15$)

RF_A: Preset divide ratio of binary 3-bit swallow counter ($0 \leq RF_A \leq 7$ for LMX2502, $0 \leq RF_A \leq 5$ for LMX2512)

RF_FN: Preset numerator of binary 11-bit modulus counter ($0 \leq RF_FN < 1920$ for $f_{OSC} = 19.20$ MHz; $0 \leq RF_FN < 1968$ for $f_{OSC} = 19.68$ MHz).

f_{OSC} : Reference oscillator frequency

NOTE: For the use of reference frequencies other than those specified, please contact Texas Instruments.

R1 REGISTER

The R1 register address bits (R1 [1:0]) are “01”.

The IF_FREQ bits selects the default IF frequency applicable to the specific CDMA system. For the LMX2502 the default IF frequency is 440.76 MHz, and for the LMX2512 the default IF frequencies are 367.20 MHz and 170.76 MHz, depending on variant.

Reference Frequency Selection bit (OSC_FREQ) selects either 19.20 MHz or 19.68 MHz for the reference oscillator frequency.

The internal spurious reduction scheme is controlled by the SPUR_RDT [1:0] bits. There are two different spur reduction schemes: a continuous tracking mode and a single optimization mode. The continuous tracking mode will adjust for variations in voltage and temperature. The single optimization mode fixes the internal compensation parameters only when the PLL goes into the locked state. The spur reduction can also be disabled, but it is recommended that the continuous mode be used for normal operation.

The OB_CRL [1:0] bits determine the power level of the RF output buffer. The power level can be set according to the system requirement.

The two bits, RF_EN and IF_EN, logically select the active state of the RF synthesizer system and the IF PLL, respectively. The entire IC can be placed in a power down state by using the CE control pin (pin 20).

Table 8. R1 REGISTER

Register	SHIFT REGISTER BIT LOCATION																				MSB		LSB	
	23	22	21	20	19	18	17	16	15	14	13	12	11	10	9	8	7	6	5	4	3	2	1	0
	Data Field																				Address Field			
R1 (Default)	IF_FREQ [1:0]	OSC_FREQ	1	0	0	0	0	0	0	0	0	SPUR_RDT [1:0]	0	0	1	0	1	OB_CRL [1:0]	RF_EN	IF_EN	0	1		

Table 9.

Name	Functions
IF_FREQ [1:0]	IF Frequency Selection 00 = 170.76 MHz (LMX2512LQ0967) 01 = 367.20 MHz (LMX2512LQ1065) 10 = 440.76 MHz (LMX2502LQ1635)
OSC_FREQ	Reference Frequency Selection 0 = 19.20 MHz 1 = 19.68 MHz
SPUR_RDT [1:0]	Spur Reduction Scheme 00 = No spur reduction 01 = Not Used 10 = Continuous tracking of variation (Recommended) 11 = One time optimization
OB_CRL [1:0]	RF Output Power Control 00 = Minimum Output Power 01 = 10 = 11 = Maximum Output Power
RF_EN	RF Enable 0 = RF Off 1 = RF On
IF_EN	IF Enable 0 = IF Off 1 = IF On

R2 REGISTER

The R2 Register address bits (R2 [1:0]) are “10”.

The IF_CUR [1:0] bits program the IF charge-pump current. Considering the external IF VCO and loop filter, the user can select the amount of IF charge pump current to be 100 μ A, 200 μ A, 300 μ A or 800 μ A.

Table 10. R2 REGISTER

Register	MSB	SHIFT REGISTER BIT LOCATION																				LSB		
	23	22	21	20	19	18	17	16	15	14	13	12	11	10	9	8	7	6	5	4	3	2	1	0
	Data Field																						Address Field	
R2 (Default)	IF_CUR[1:0]	0	0	1	0	0	1	1	1	0	1	1	0	1	0	1	0	0	0	0	1	0	1	0

Table 11.

Name	Functions
IF_CUR [1:0]	IF Charge Pump Current 00 = 100 μ A 01 = 200 μ A 10 = 300 μ A 11 = 800 μ A

R3 REGISTER

The R3 register address bits (R3 [2:0]) are “011”.

Register R3 contains the controls for the phase lock bandwidth controls (BW_DUR, BW_CRL, and BW_EN). The duration of the digital controller portion of the bandwidth control is set by BW_DUR [1:0]. The minimum time set with 00 and increasing durations to the maximum value set with 11. BW_CRL [1:0] sets the phase offset criterion for the bandwidth controller. Once the phase offset between the reference clock and the divided VCO signal are within the set criterion, the bandwidth control stops. The maximum phase offset is set with 00 and decreases to the minimum value set with 11. BW_EN enables the bandwidth control in the locking state.

The VCO dynamic current is also controlled in register R3 with VCO_CUR [1:0]. The minimum value corresponds to 00 and increases to a maximum value set at 11.

Table 12. R3 REGISTER

Register	SHIFT REGISTER BIT LOCATION																				LSB		
	23	22	21	20	19	18	17	16	15	14	13	12	11	10	9	8	7	6	5	4	3	2	1
	Data Field																				Address Field		
R3 (Default)	BW_DUR [1:0]	BW_CRL [1:0]	BW_EN	1	0	1	1	1	1	1	0	1	0	0	0	1	1	0	VCO_CUR [1:0]	0	1	1	

Table 13.

Name	Functions
BW_DUR [1:0]	Bandwidth Duration 00 = Minimum value (Recommended) 01 = 10 = 11 = Maximum value
BW_CRL [1:0]	Bandwidth Control 00 = Maximum phase offset (Recommended) 01 = 10 = 11 = Minimum phase offset
BW_EN	Bandwidth Enable 0 = Disable 1 = Enable (Recommended)
VCO_CUR [1:0]	VCO Dynamic Current 00 = Minimum value 01 = 10 = 11 = Maximum value (Recommended)

R4 REGISTER

The R4 register address bits (R3 [3:0]) are “0111”.

Register R4 is used to set the IF N counters if the default value is not desired. This register is only active if the SPI_DEF bit in register R0 is 0.

Table 14. R4 REGISTER

Register	SHIFT REGISTER BIT LOCATION																				MSB	LSB	
	23	22	21	20	19	18	17	16	15	14	13	12	11	10	9	8	7	6	5	4			3
	Data Field																			Address Field			
R4	0	0	0	1	0	0	0	IF_A [3:0]				IF_B [8:0]					0	1	1	1			

Table 15.

Name	Functions
IF_A [3:0]	IF A Counter 4-bit swallow counter 0 ≤ IF_A ≤ 15
IF_B [8:0]	IF B Counter 9-bit programmable counter 1 ≤ IF_B ≤ 511

IF Frequency Setting:

$$f_{VCO} = \{16 \times IF_B + IF_A\} \times f_{OSC} / IF_R \text{ where } (IF_A < IF_B)$$

where

- f_{VCO} : Output frequency of IF voltage controlled oscillator (IF VCO)
- IF_B: Preset divide ratio of binary 9-bit programmable counter (1 ≤ IF_B ≤ 511)
- IF_A: Preset divide ratio of binary 4-bit swallow counter (0 ≤ IF_A ≤ 15)
- IF_R: Preset divide ratio of binary 9-bit programmable reference counter (2 ≤ IF_R ≤ 511)
- f_{OSC} : Reference oscillator frequency

R5 REGISTER

The R5 register address bits (R5 [4:0]) are “01111”.

Register R5 is used to set the IF_R divider if the default value is not desired. This register is only active if the SPI_DEF bit in register R0 is 0.

Table 16. R5 REGISTER

Register	SHIFT REGISTER BIT LOCATION																				MSB	LSB	
	23	22	21	20	19	18	17	16	15	14	13	12	11	10	9	8	7	6	5	4			3
	Data Field															Address Field							
R5	0	0	1	1	0	0	0	0	1	0	IF_R [8:0]					0	1	1	1	1	1		

Table 17.

Name	Functions
IF_R [8:0]	IF R Counter 9-bit programmable counter $2 \leq \text{IF_R} \leq 511$

R6 REGISTER

The R6 register address bits (R6 [5:0]) are “011111”.

Register R6 is used for internal testing of the device and is not intended for customer use. This register is only active if the SPI_DEF bit in register R0 is 0.

Table 18. R6 REGISTER

Register	SHIFT REGISTER BIT LOCATION																				MSB	LSB							
	23	22	21	20	19	18	17	16	15	14	13	12	11	10	9	8	7	6	5	4			3	2	1	0			
	Data Field															Address Field													
R6	1	0	0	0	0	0	0	0	0	0	0	0	0	0	0	0	0	0	0	0	0	1	1	1	1	1	1		

REVISION HISTORY

Changes from Revision B (April 2013) to Revision C	Page
• Changed layout of National Data Sheet to TI format	17

PACKAGING INFORMATION

Orderable Device	Status (1)	Package Type	Package Drawing	Pins	Package Qty	Eco Plan (2)	Lead/Ball Finish (6)	MSL Peak Temp (3)	Op Temp (°C)	Device Marking (4/5)	Samples
LMX2502LQ1635/NOPB	ACTIVE	WQFN	NJB	28	1000	Green (RoHS & no Sb/Br)	CU SN	Level-3-260C-168 HR	-30 to 85	25021635	Samples
LMX2512LQ0967/NOPB	ACTIVE	WQFN	NJB	28	1000	Green (RoHS & no Sb/Br)	CU SN	Level-3-260C-168 HR	-30 to 85	25120967	Samples

(1) The marketing status values are defined as follows:

ACTIVE: Product device recommended for new designs.

LIFEBUY: TI has announced that the device will be discontinued, and a lifetime-buy period is in effect.

NRND: Not recommended for new designs. Device is in production to support existing customers, but TI does not recommend using this part in a new design.

PREVIEW: Device has been announced but is not in production. Samples may or may not be available.

OBSOLETE: TI has discontinued the production of the device.

(2) Eco Plan - The planned eco-friendly classification: Pb-Free (RoHS), Pb-Free (RoHS Exempt), or Green (RoHS & no Sb/Br) - please check <http://www.ti.com/productcontent> for the latest availability information and additional product content details.

TBD: The Pb-Free/Green conversion plan has not been defined.

Pb-Free (RoHS): TI's terms "Lead-Free" or "Pb-Free" mean semiconductor products that are compatible with the current RoHS requirements for all 6 substances, including the requirement that lead not exceed 0.1% by weight in homogeneous materials. Where designed to be soldered at high temperatures, TI Pb-Free products are suitable for use in specified lead-free processes.

Pb-Free (RoHS Exempt): This component has a RoHS exemption for either 1) lead-based flip-chip solder bumps used between the die and package, or 2) lead-based die adhesive used between the die and leadframe. The component is otherwise considered Pb-Free (RoHS compatible) as defined above.

Green (RoHS & no Sb/Br): TI defines "Green" to mean Pb-Free (RoHS compatible), and free of Bromine (Br) and Antimony (Sb) based flame retardants (Br or Sb do not exceed 0.1% by weight in homogeneous material)

(3) MSL, Peak Temp. - The Moisture Sensitivity Level rating according to the JEDEC industry standard classifications, and peak solder temperature.

(4) There may be additional marking, which relates to the logo, the lot trace code information, or the environmental category on the device.

(5) Multiple Device Markings will be inside parentheses. Only one Device Marking contained in parentheses and separated by a "~" will appear on a device. If a line is indented then it is a continuation of the previous line and the two combined represent the entire Device Marking for that device.

(6) Lead/Ball Finish - Orderable Devices may have multiple material finish options. Finish options are separated by a vertical ruled line. Lead/Ball Finish values may wrap to two lines if the finish value exceeds the maximum column width.

Important Information and Disclaimer: The information provided on this page represents TI's knowledge and belief as of the date that it is provided. TI bases its knowledge and belief on information provided by third parties, and makes no representation or warranty as to the accuracy of such information. Efforts are underway to better integrate information from third parties. TI has taken and continues to take reasonable steps to provide representative and accurate information but may not have conducted destructive testing or chemical analysis on incoming materials and chemicals. TI and TI suppliers consider certain information to be proprietary, and thus CAS numbers and other limited information may not be available for release.

In no event shall TI's liability arising out of such information exceed the total purchase price of the TI part(s) at issue in this document sold by TI to Customer on an annual basis.

TAPE AND REEL INFORMATION



QUADRANT ASSIGNMENTS FOR PIN 1 ORIENTATION IN TAPE



*All dimensions are nominal

Device	Package Type	Package Drawing	Pins	SPQ	Reel Diameter (mm)	Reel Width W1 (mm)	A0 (mm)	B0 (mm)	K0 (mm)	P1 (mm)	W (mm)	Pin1 Quadrant
LMX2502LQ1635/NOPB	WQFN	NJB	28	1000	178.0	12.4	5.3	5.3	1.3	8.0	12.0	Q1
LMX2512LQ0967/NOPB	WQFN	NJB	28	1000	178.0	12.4	5.3	5.3	1.3	8.0	12.0	Q1

TAPE AND REEL BOX DIMENSIONS

*All dimensions are nominal

Device	Package Type	Package Drawing	Pins	SPQ	Length (mm)	Width (mm)	Height (mm)
LMX2502LQ1635/NOPB	WQFN	NJB	28	1000	213.0	191.0	55.0
LMX2512LQ0967/NOPB	WQFN	NJB	28	1000	213.0	191.0	55.0

IMPORTANT NOTICE

Texas Instruments Incorporated and its subsidiaries (TI) reserve the right to make corrections, enhancements, improvements and other changes to its semiconductor products and services per JESD46, latest issue, and to discontinue any product or service per JESD48, latest issue. Buyers should obtain the latest relevant information before placing orders and should verify that such information is current and complete. All semiconductor products (also referred to herein as "components") are sold subject to TI's terms and conditions of sale supplied at the time of order acknowledgment.

TI warrants performance of its components to the specifications applicable at the time of sale, in accordance with the warranty in TI's terms and conditions of sale of semiconductor products. Testing and other quality control techniques are used to the extent TI deems necessary to support this warranty. Except where mandated by applicable law, testing of all parameters of each component is not necessarily performed.

TI assumes no liability for applications assistance or the design of Buyers' products. Buyers are responsible for their products and applications using TI components. To minimize the risks associated with Buyers' products and applications, Buyers should provide adequate design and operating safeguards.

TI does not warrant or represent that any license, either express or implied, is granted under any patent right, copyright, mask work right, or other intellectual property right relating to any combination, machine, or process in which TI components or services are used. Information published by TI regarding third-party products or services does not constitute a license to use such products or services or a warranty or endorsement thereof. Use of such information may require a license from a third party under the patents or other intellectual property of the third party, or a license from TI under the patents or other intellectual property of TI.

Reproduction of significant portions of TI information in TI data books or data sheets is permissible only if reproduction is without alteration and is accompanied by all associated warranties, conditions, limitations, and notices. TI is not responsible or liable for such altered documentation. Information of third parties may be subject to additional restrictions.

Resale of TI components or services with statements different from or beyond the parameters stated by TI for that component or service voids all express and any implied warranties for the associated TI component or service and is an unfair and deceptive business practice. TI is not responsible or liable for any such statements.

Buyer acknowledges and agrees that it is solely responsible for compliance with all legal, regulatory and safety-related requirements concerning its products, and any use of TI components in its applications, notwithstanding any applications-related information or support that may be provided by TI. Buyer represents and agrees that it has all the necessary expertise to create and implement safeguards which anticipate dangerous consequences of failures, monitor failures and their consequences, lessen the likelihood of failures that might cause harm and take appropriate remedial actions. Buyer will fully indemnify TI and its representatives against any damages arising out of the use of any TI components in safety-critical applications.

In some cases, TI components may be promoted specifically to facilitate safety-related applications. With such components, TI's goal is to help enable customers to design and create their own end-product solutions that meet applicable functional safety standards and requirements. Nonetheless, such components are subject to these terms.

No TI components are authorized for use in FDA Class III (or similar life-critical medical equipment) unless authorized officers of the parties have executed a special agreement specifically governing such use.

Only those TI components which TI has specifically designated as military grade or "enhanced plastic" are designed and intended for use in military/aerospace applications or environments. Buyer acknowledges and agrees that any military or aerospace use of TI components which have **not** been so designated is solely at the Buyer's risk, and that Buyer is solely responsible for compliance with all legal and regulatory requirements in connection with such use.

TI has specifically designated certain components as meeting ISO/TS16949 requirements, mainly for automotive use. In any case of use of non-designated products, TI will not be responsible for any failure to meet ISO/TS16949.

Products

Audio	www.ti.com/audio
Amplifiers	amplifier.ti.com
Data Converters	dataconverter.ti.com
DLP® Products	www.dlp.com
DSP	dsp.ti.com
Clocks and Timers	www.ti.com/clocks
Interface	interface.ti.com
Logic	logic.ti.com
Power Mgmt	power.ti.com
Microcontrollers	microcontroller.ti.com
RFID	www.ti-rfid.com
OMAP Applications Processors	www.ti.com/omap
Wireless Connectivity	www.ti.com/wirelessconnectivity

Applications

Automotive and Transportation	www.ti.com/automotive
Communications and Telecom	www.ti.com/communications
Computers and Peripherals	www.ti.com/computers
Consumer Electronics	www.ti.com/consumer-apps
Energy and Lighting	www.ti.com/energy
Industrial	www.ti.com/industrial
Medical	www.ti.com/medical
Security	www.ti.com/security
Space, Avionics and Defense	www.ti.com/space-avionics-defense
Video and Imaging	www.ti.com/video

TI E2E Community

e2e.ti.com