



Precision LOGARITHMIC AND LOG RATIO AMPLIFIER

FEATURES

- EASY-TO-USE COMPLETE LOG RATIO FUNCTION
- OUTPUT AMPLIFIERS FOR SCALING AND SIGNAL LOSS INDICATION
- HIGH ACCURACY: 0.15% FSO Total Error Over 6 Decades
- WIDE INPUT DYNAMIC RANGE: 6 Decades, 1nA to 1mA
- LOW QUIESCENT CURRENT: 1.25mA
- SO-14 PACKAGE

APPLICATIONS

- ONET, OPTICAL POWER METERS
- LOG, LOG RATIO COMPUTATION: Communication, Analytical, Medical, Industrial, Test, General Instrumentation
- PHOTODIODE SIGNAL COMPRESSION AMP
- ANALOG SIGNAL COMPRESSION IN FRONT OF A/D CONVERTER
- ABSORBANCE MEASUREMENT
- OPTICAL DENSITY MEASUREMENT

DESCRIPTION

The LOG102 is a versatile integrated circuit that computes the logarithm or log ratio of an input current relative to a reference current.

The LOG102 is tested over a wide dynamic range of input signals. In log ratio applications, a signal current can be generated by a photodiode, and a reference current from a resistor in series with a precision external voltage reference.

In the block diagram shown below, A3 and A4 are identical, uncommitted op amps that can be used for a variety of functions, such as filtering, offsetting, adding gain or as a comparator to detect loss of signal.

The output signal at $V_{LOG OUT}$ is trimmed to 1V per decade of input current. It can be scaled with an output amplifier, either A3 or A4.

Low dc offset voltage and temperature drift allow accurate measurement of low-level signals over a wide environmental temperature range. The LOG102 is specified over the temperature range, 0°C to +70°C, with operation over -40°C to +85°C.

NOTE: U.S. Patent Pending.

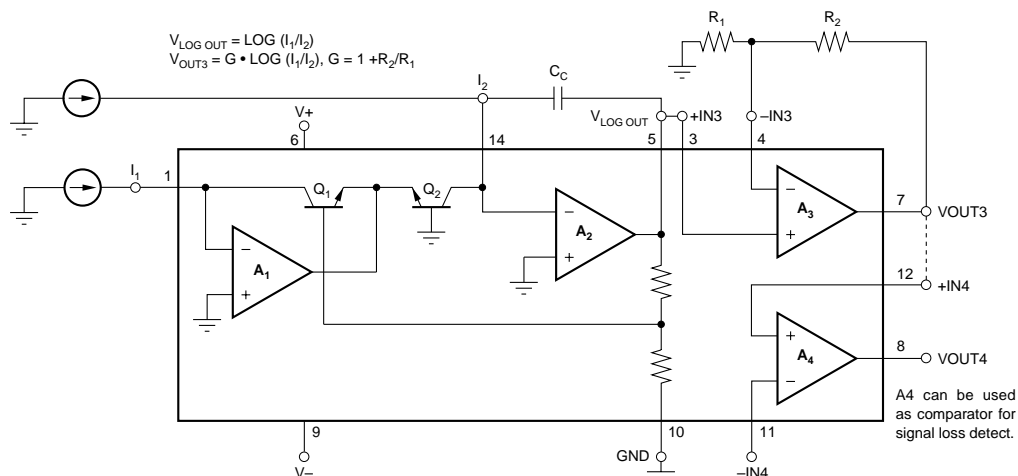

Please be aware that an important notice concerning availability, standard warranty, and use in critical applications of Texas Instruments semiconductor products and disclaimers thereto appears at the end of this data sheet.

All trademarks are the property of their respective owners.

PRODUCTION DATA information is current as of publication date. Products conform to specifications per the terms of Texas Instruments standard warranty. Production processing does not necessarily include testing of all parameters.



Copyright © 2001-2005, Texas Instruments Incorporated

ABSOLUTE MAXIMUM RATINGS⁽¹⁾

Supply Voltage, V+ to V-	36V
Input Voltage	V- (-0.5) to V+ (+0.5V)
Input Current	±10mA
Output Short-Circuit ⁽²⁾	Continuous
Operating Temperature	-40°C to +85°C
Storage Temperature	-55°C to +125°C
Junction Temperature	+150°C
Lead Temperature (soldering, 10s)	+300°C

NOTES: (1) Stresses above these ratings may cause permanent damage. Exposure to absolute maximum conditions for extended periods may degrade device reliability. (2) Short circuit to ground, one amplifier per package.

ELECTROSTATIC DISCHARGE SENSITIVITY

This integrated circuit can be damaged by ESD. Texas Instruments recommends that all integrated circuits be handled with appropriate precautions. Failure to observe proper handling and installation procedures can cause damage.

ESD damage can range from subtle performance degradation to complete device failure. Precision integrated circuits may be more susceptible to damage because very small parametric changes could cause the device not to meet its published specifications.

PIN DESCRIPTION

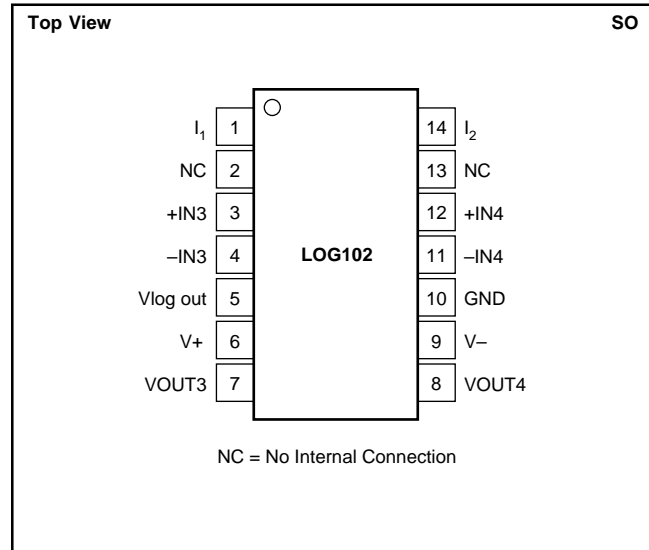

PACKAGE/ORDERING INFORMATION⁽¹⁾

PRODUCT	PACKAGE-LEAD	PACKAGE DESIGNATOR	PACKAGE MARKING
LOG102AID	SO-14	D	LOG102A

NOTES: (1) For the most current package and ordering information, see the Package Option Addendum at the end of this document, or see the TI website at www.ti.com.

ELECTRICAL CHARACTERISTICS

Boldface limits apply over the specified temperature range, $T_A = 0^\circ\text{C}$ to $+70^\circ\text{C}$.

At $T_A = +25^\circ\text{C}$, $V_S = \pm 5\text{V}$, $R_L = 10\text{k}\Omega$, unless otherwise noted.

PARAMETER	CONDITION	LOG102AID			UNITS
		MIN	TYP	MAX	
CORE LOG FUNCTION $I_{IN}/V_{LOG\ OUT}$ Equation			$V_O = \log(I_1/I_2)$		
LOG CONFORMITY ERROR⁽¹⁾ Initial	1nA to 100 μ A (5 decades) 1nA to 1mA (6 decades)		0.04 0.15	±0.3	% %
over Temperature	1nA to 100μA (5 decades) 1nA to 1mA (6 decades)		0.0002 0.002		%/°C %/°C
GAIN⁽²⁾ Initial Value	1nA to 100 μ A (5 decades)		1		V/decade
Gain Error	1nA to 100 μ A (5 decades)		0.15	±1	%
vs Temperature	T_{MIN} to T_{MAX}		0.025	0.05	%/°C
INPUT, A1 and A2 Offset Voltage	T_{MIN} to T_{MAX} $V_S = \pm 4.5\text{V}$ to $\pm 18\text{V}$		±0.3 ±2	±1.5	mV $\mu\text{V}/^\circ\text{C}$
vs Temperature vs Power Supply (PSRR)			5	50	$\mu\text{V}/\text{V}$
Input Bias Current	T_{MIN} to T_{MAX} $f = 10\text{Hz}$ to 10kHz $f = 1\text{kHz}$ $f = 1\text{kHz}$		±5		pA
vs Temperature Voltage Noise			Doubles Every 10°C		μVrms
Current Noise			30		$\text{nV}/\sqrt{\text{Hz}}$
Common-Mode Voltage Range (Positive)		(V+) - 2	(V+) - 1.5		V
(Negative)		(V-) + 2	(V-) + 1.2		V
CMRR		90	105		dB
OUTPUT, A2 (V_{LOGOUT}) Output Offset, V_{OSO} , Initial	T_{MIN} to T_{MAX} $V_S = \pm 5\text{V}$ Supplies		±3	±55	mV
vs Temperature Full-Scale Output (FSO)				25	(V+) - 1.5
Short-Circuit Current			±18		mA

TYPICAL CHARACTERISTICS

At $T_A = +25^\circ\text{C}$, $V_S = \pm 5\text{V}$, $R_L = 10\text{k}\Omega$, unless otherwise noted.

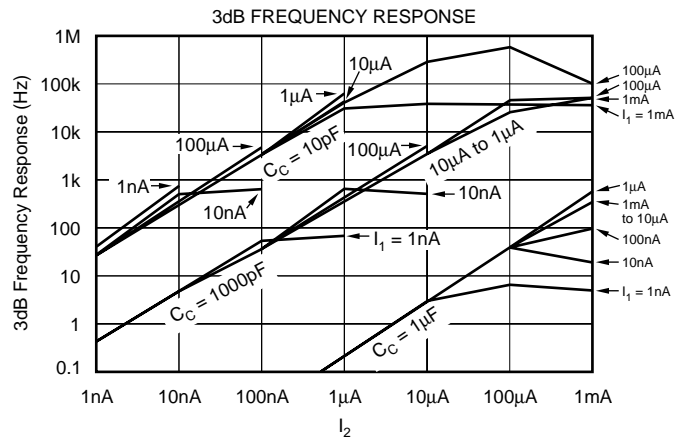
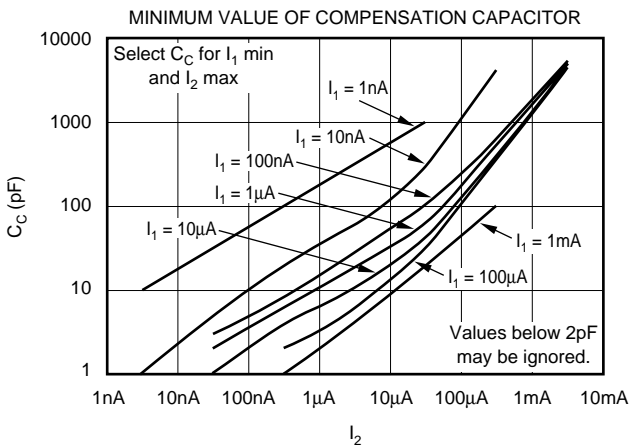
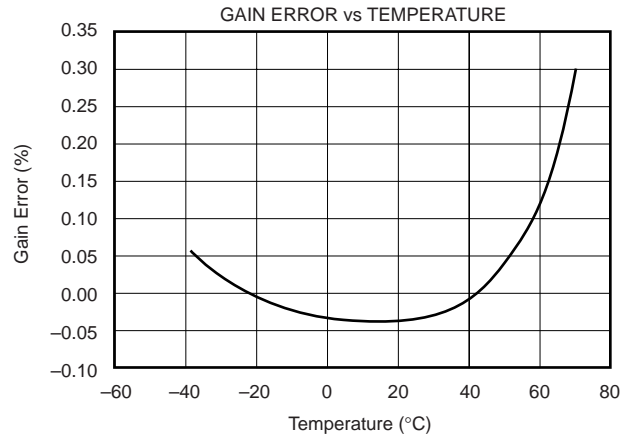
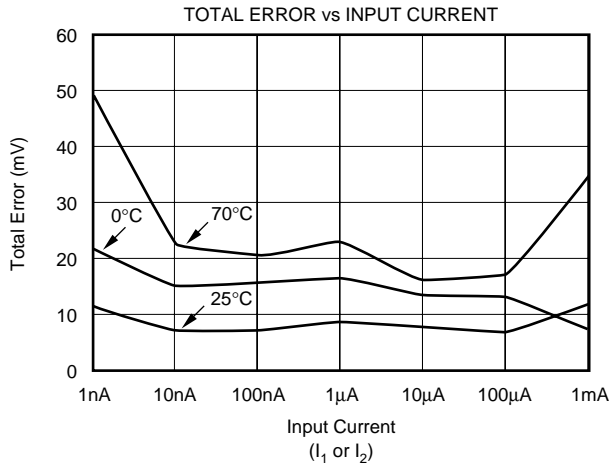
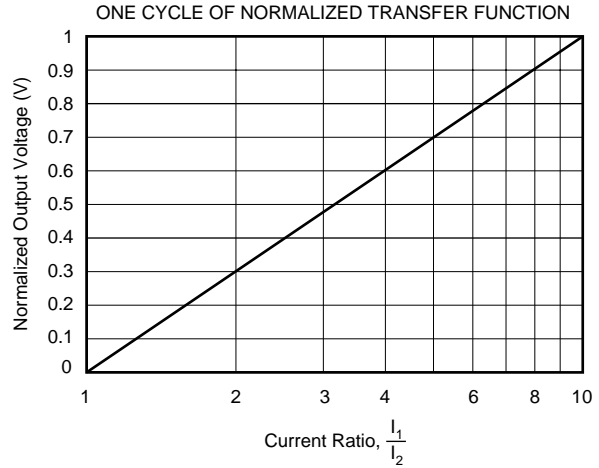
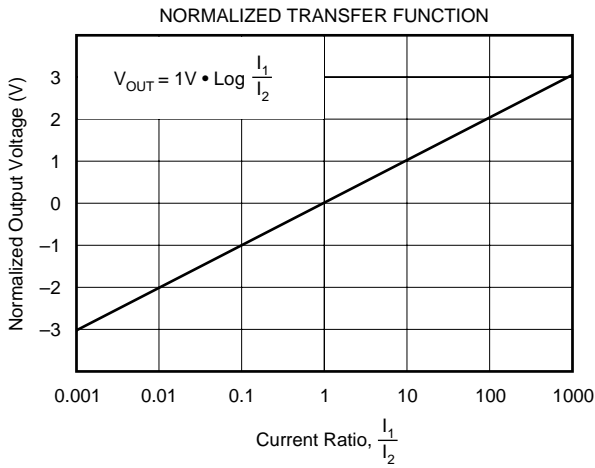

TYPICAL CHARACTERISTICS (Cont.)

At $T_A = +25^\circ\text{C}$, $V_S = \pm 5\text{V}$, $R_L = 10\text{k}\Omega$, unless otherwise noted.

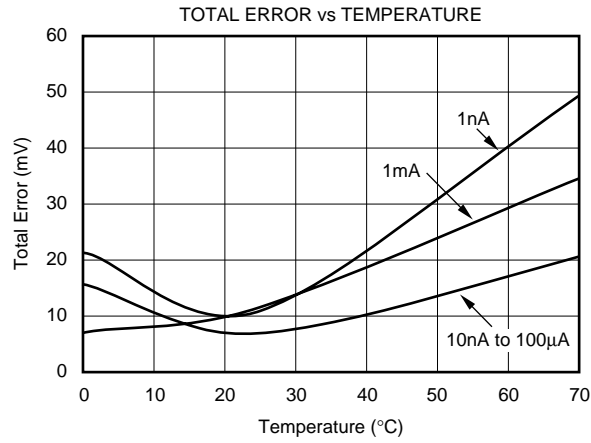
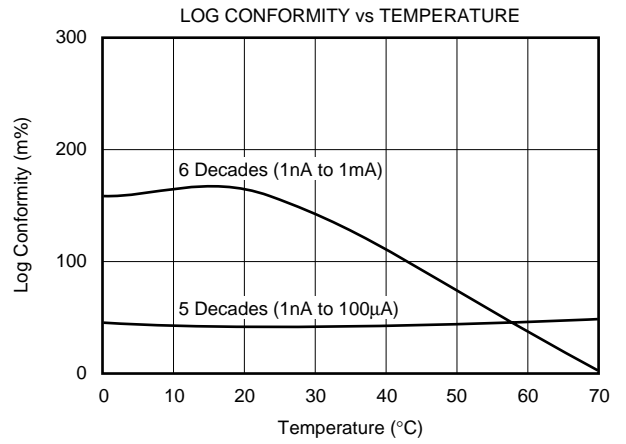
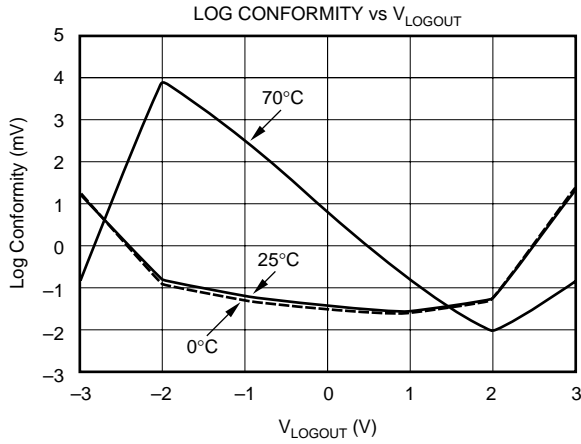

APPLICATION INFORMATION

The LOG102 is a true logarithmic amplifier that uses the base-emitter voltage relationship of bipolar transistors to compute the logarithm, or logarithmic ratio, of a current ratio. With two uncommitted on-chip operational amplifiers, the LOG102 provides design flexibility and simplicity.

Figure 1 shows the basic connections required for operation of the LOG102 with a gain factor. In order to reduce the influence of lead inductance of power supply lines, it is recommended that each supply be bypassed with a 10µF tantalum capacitor in parallel with a 1000pF ceramic capacitor, as shown in Figure 1. Connecting the capacitors as close to the LOG102 as possible will contribute to noise reduction as well.

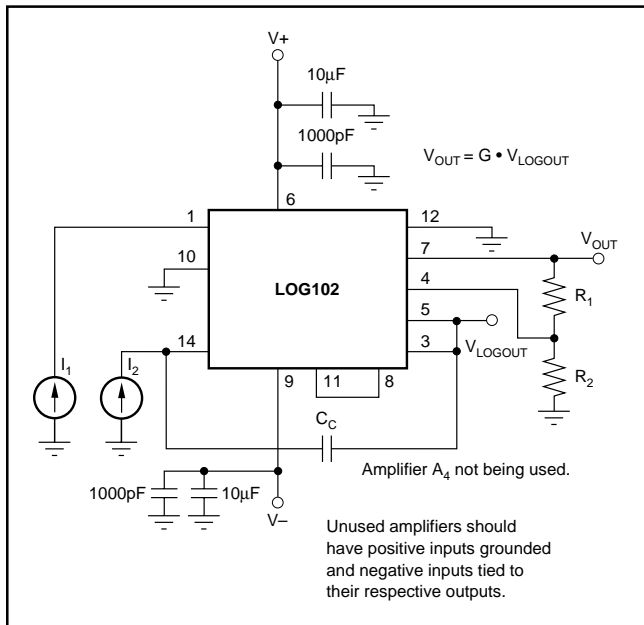

FIGURE 1. Basic Connections with Output Gain Factor of the LOG102.

INPUT CURRENT RANGE

To maintain specified accuracy, the input current range of the LOG102 should be limited from 1nA to 1mA. Input currents outside of this range may compromise LOG102 performance. Input currents larger than 1mA result in increased nonlinearity. An absolute maximum input current rating of 10mA is included to prevent excessive power dissipation that may damage the logging transistor.

On ±5V supplies the total input current ($I_1 + I_2$) is limited to 1.1mA. Due to compliance issues internal to the LOG102, to accommodate larger total input currents, supplies should be increased.

Currents smaller than 1nA will result in increased errors due the input bias currents of op amps A_1 and A_2 (typically 5pA). The input bias currents may be compensated for, as shown in Figure 2. The input stages of the amplifiers have FET inputs, with input bias current doubling every 10°C, which makes the nulling technique shown practical only where the temperature is fairly stable.

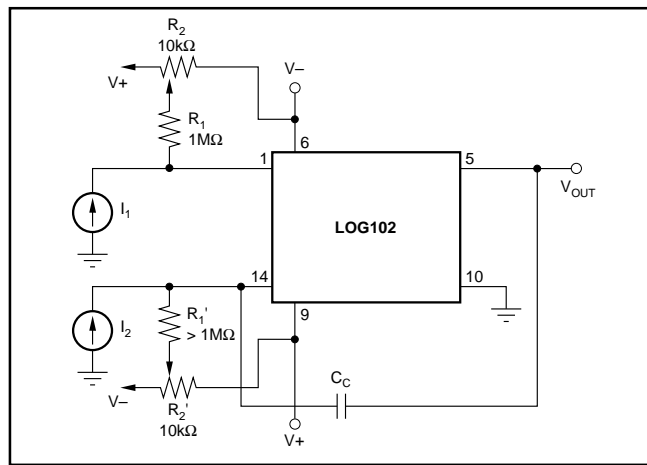

FIGURE 2. Bias Current Nulling.

SETTING THE REFERENCE CURRENT

When the LOG102 is used to compute logarithms, either I_1 or I_2 can be held constant and becomes the reference current to which the other is compared.

V_{LOGOUT} is expressed as:

$$V_{LOGOUT} = (1V) \cdot \log(I_1/I_2) \quad (1)$$

I_{REF} can be derived from an external current source (such as shown in Figure 3), or it may be derived from a voltage source with one or more resistors. When a single resistor is used, the value may be large depending on I_{REF} . If I_{REF} is 10nA and +2.5V is used:

$$R_{REF} = 2.5V/10nA = 250M\Omega$$

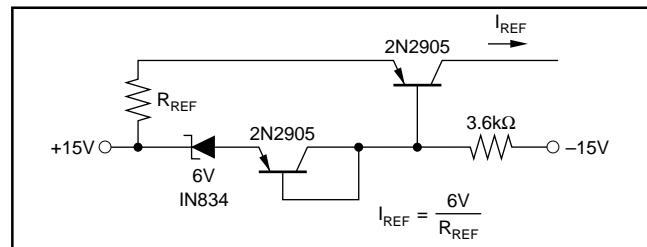

FIGURE 3. Temperature Compensated Current Source.

A voltage divider may be used to reduce the value of the resistor (as shown in Figure 4). When using this method, one must consider the possible errors caused by the amplifier's input offset voltage. The input offset voltage of amplifier A_1 has a maximum value of 1.5mV, making V_{REF} a suggested value of 100mV.

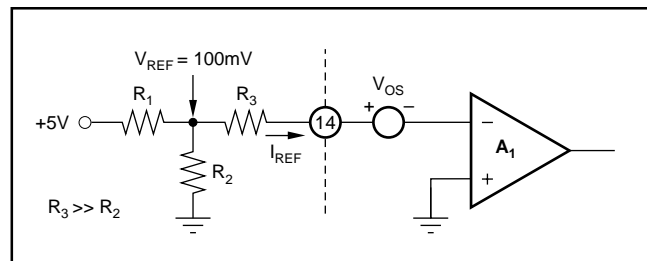

FIGURE 4. T Network for Reference Current.

Figure 5 shows a low-level current source using a series resistor. The low offset op-amp reduces the effect of the LOG102's input offset voltage.

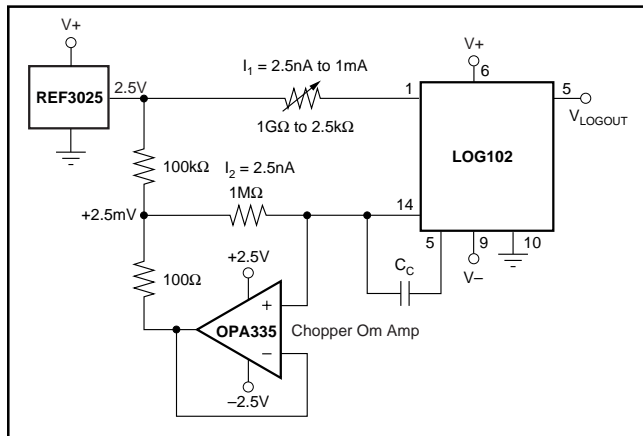

FIGURE 5. Current Source with Offset Compensation.

FREQUENCY RESPONSE

The 3dB frequency response of the LOG102 is a function of the magnitude of the input current levels and of the value of the frequency compensation capacitor. See Typical Characteristic Curves for details.

The frequency response curves are shown for constant DC I_1 and I_2 with a small signal AC current on one of them.

The transient response of the LOG102 is different for increasing and decreasing signals. This is due to the fact that a log amp is a nonlinear gain element and has different gains at different levels of input signals. Smaller input currents require greater gain to maintain full dynamic range, and will slow the frequency response of the LOG102.

FREQUENCY COMPENSATION

Frequency compensation for the LOG102 is obtained by connecting a capacitor between pins 5 and 14. The size of the capacitor is a function of the input currents, as shown in the Typical Characteristic Curves (Minimum Value of Compensation Capacitor). For any given application, the smallest value of the capacitor which may be used is determined by the maximum value of I_2 and the minimum value of I_1 . Larger values of C_C will make the LOG102 more stable, but will reduce the frequency response.

In an application, highest overall bandwidth can be achieved by detecting the signal level at V_{OUT} , then switching in appropriate values of compensation capacitors.

As seen on front page diagram, the voltage output of V_{LOGOUT} can be scaled by increasing or decreasing the resistor ratio connected to pins 4 and 7. The gain, G , can be set according to the following equation:

$$G = 1 + R_2/R_1 \quad (2)$$

NEGATIVE INPUT CURRENTS

The LOG102 will function only with positive input currents (conventional current flow into pins 1 and 14). In situations where negative input currents are needed, the circuits in Figures 6, 7, 8, and 9, may be used.

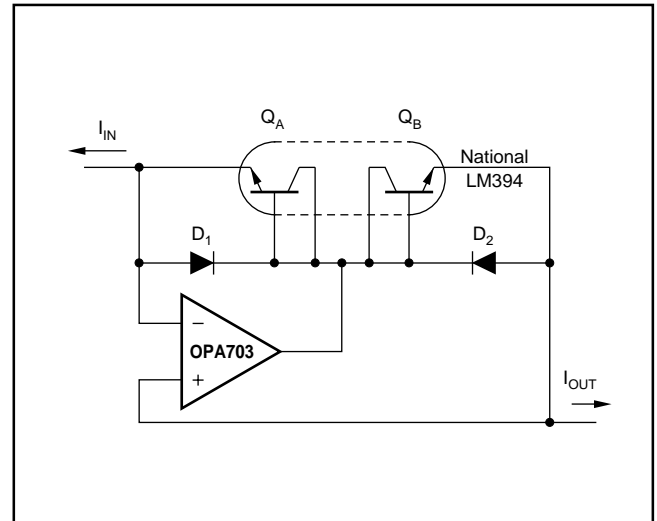

FIGURE 6. Current Inverter/Current Source.

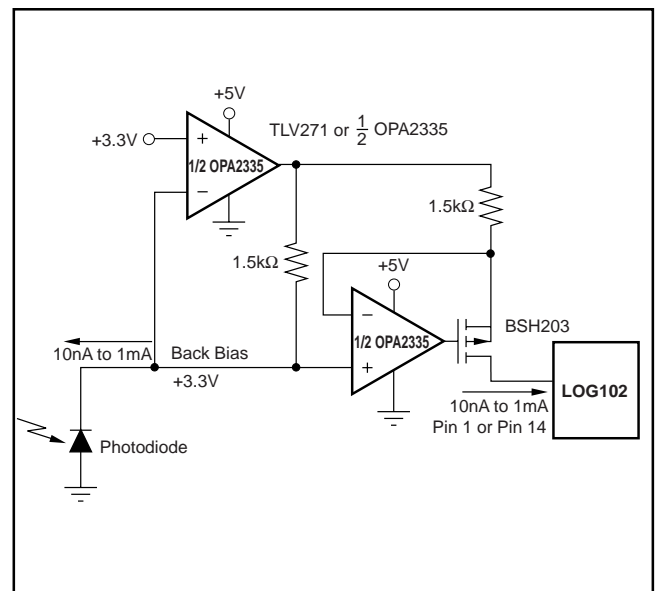

FIGURE 7. Precision Current Inverter/Current Source.

VOLTAGE INPUTS

The LOG102 gives the best performance with current inputs. Voltage inputs may be handled directly with series resistors, but the dynamic input range is limited to approximately three decades of input voltage by voltage noise and offsets. The transfer function of equation (14) applies to this configuration.

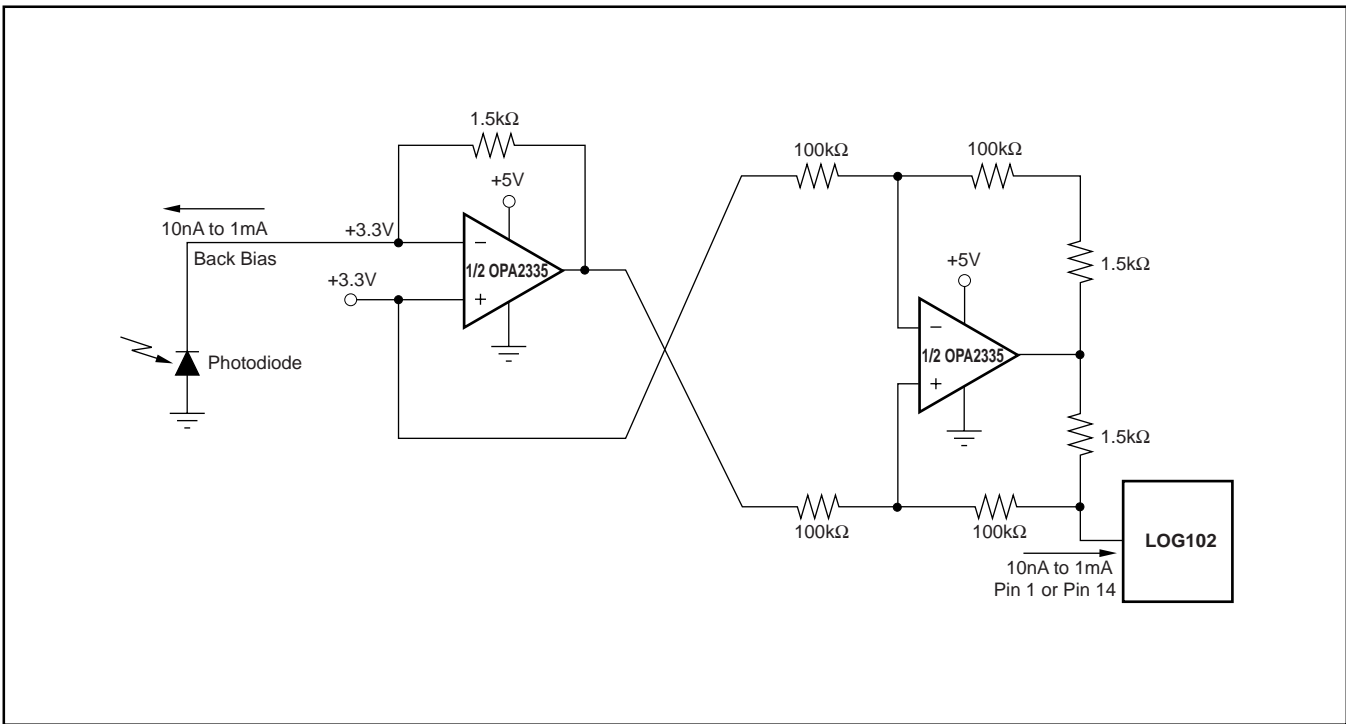

FIGURE 8. Precision Current Inverter/Current Source.

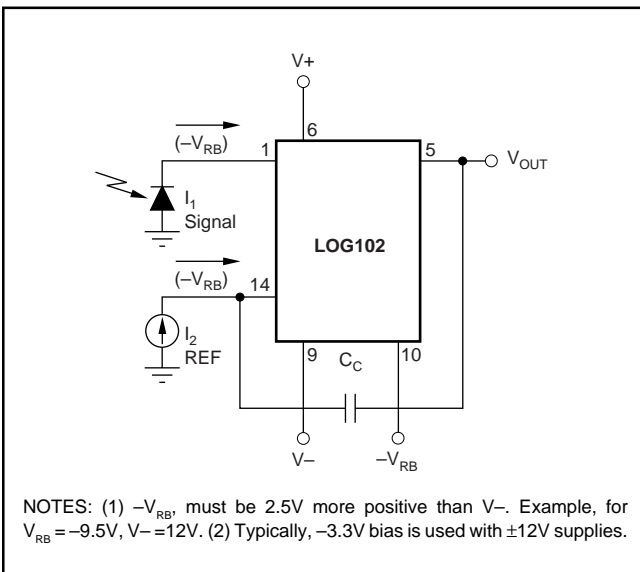

FIGURE 9. Reverse Biased Photodiode Using Pin 10 on LOG102.

DATA COMPRESSION

In many applications the compressive effects of the logarithmic transfer function are useful. For example, a LOG102 preceding a 12-bit Analog-to-Digital (A/D) converter can produce the dynamic range equivalent to a 20-bit converter.

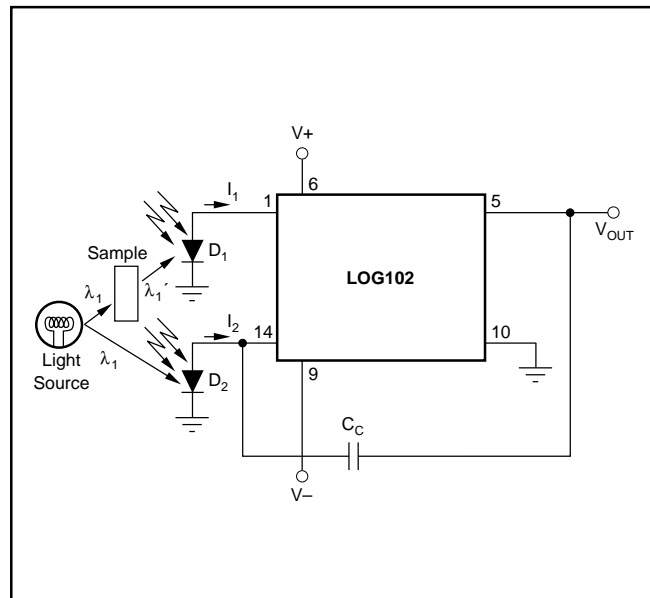

FIGURE 10. Absorbance Measurement.

APPLICATION CIRCUITS

LOG RATIO

One of the more common uses of log ratio amplifiers is to measure absorbance. A typical application is shown in Figure 10.

$$\text{Absorbance of the sample is } A = \log \lambda_1' / \lambda_1 \quad (3)$$

$$\text{If } D_1 \text{ and } D_2 \text{ are matched } A \propto (1V) \log I_1 / I_2 \quad (4)$$

INSIDE THE LOG102

Using the base-emitter voltage relationship of matched bipolar transistors, the LOG102 establishes a logarithmic function of input current ratios. Beginning with the base-emitter voltage defined as

$$V_{BE} = V_T \ln \frac{I_C}{I_S} \quad \text{where: } V_T = \frac{kT}{q} \quad (1)$$

k = Boltzmann's constant = $1.381 \cdot 10^{-23}$

T = Absolute temperature in degrees Kelvin

q = Electron charge = $1.602 \cdot 10^{-19}$ Coulombs

I_C = Collector current

I_S = Reverse saturation current

From the circuit in Figure 11, we see that

$$V_L = V_{BE1} - V_{BE2} \quad (2)$$

Substituting (1) into (2) yields

$$V_L = V_{T1} \ln \frac{I_1}{I_{S1}} - V_{T2} \ln \frac{I_2}{I_{S2}} \quad (3)$$

If the transistors are matched and isothermal and $V_{T1} = V_{T2}$, then (3) becomes:

$$V_L = V_{T1} \left[\ln \frac{I_1}{I_S} - \ln \frac{I_2}{I_S} \right] \quad (4)$$

$$V_L = V_T \ln \frac{I_1}{I_2} \quad \text{and since} \quad (5)$$

$$\ln x = 2.3 \log_{10} x \quad (6)$$

$$V_L = n V_T \log \frac{I_1}{I_2} \quad (7)$$

$$\text{where } n = 2.3 \quad (8)$$

also

$$V_{OUT} = V_L \frac{R_1 + R_2}{R_1} \quad (9)$$

$$= \log \frac{I_1}{I_2} \quad (10)$$

or

$$V_{OUT} = \frac{R_1 + R_2}{R_1} n V_T \log \frac{I_1}{I_2} \quad (11)$$

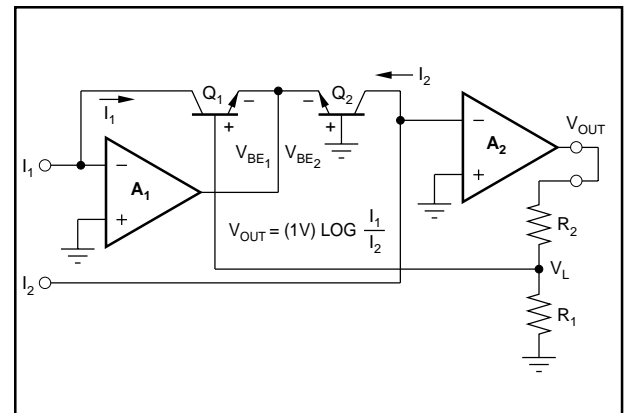

FIGURE 11. Simplified Model of Log Amplifier.

It should be noted that the temperature dependence associated with $V_T = kT/q$ is internally compensated on the LOG102 by making R_1 a temperature sensitive resistor with the required positive temperature coefficient.

USING A LARGER REFERENCE VOLTAGE REDUCES OFFSET ERRORS

Using a larger reference voltage to create the reference current minimizes errors due to the LOG102's input offset voltage. Maintaining an increasing output voltage as a function of increasing photodiode current is also important in many optical sensing applications. All zeros from the A/D converter output represent zero or low scale photodiode current. Inputting the reference current into I_1 , and designing

I_{REF} such that it is as large or larger than the expected maximum photodiode current is accomplished using this requirement. The LOG102 configured with the reference current connecting I_1 and the photodiode current connecting to I_2 is shown in Figure 12. A_3 is configured as a level shifter with inverting gain and is used to scale the photodiode current directly into the A/D input voltage range.

The wide dynamic range of the LOG102 is useful for measuring avalanche photodiode current (APD) (see Figure 13).

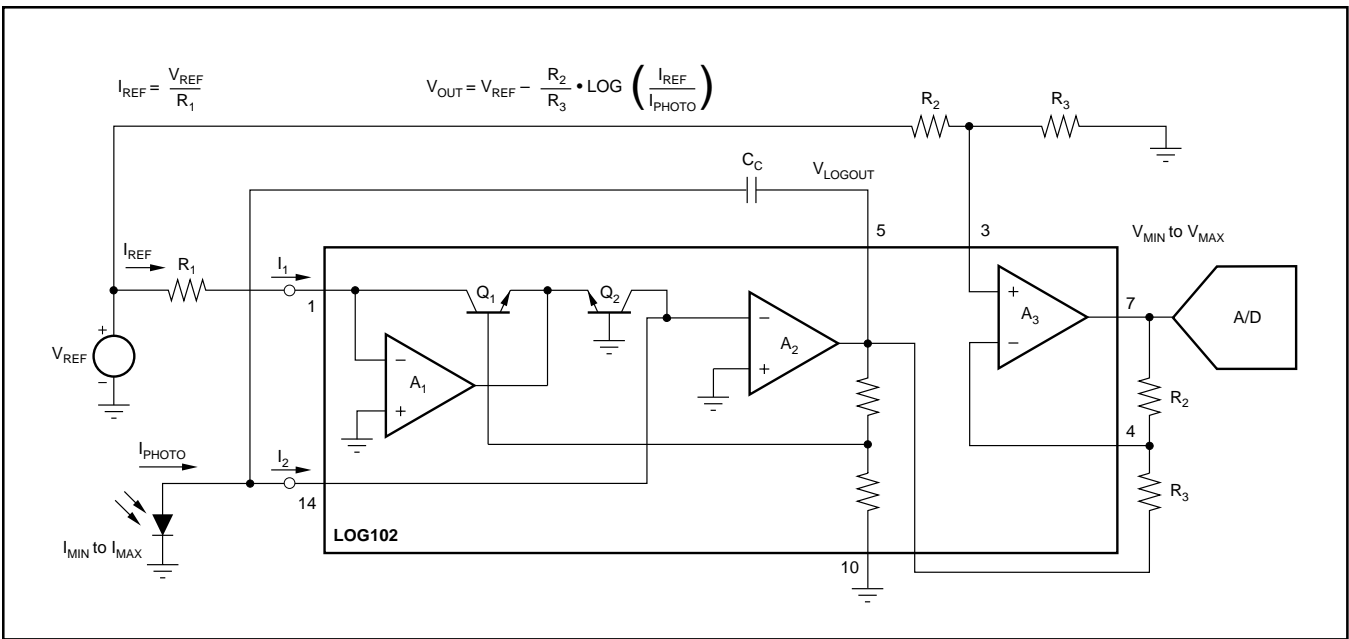
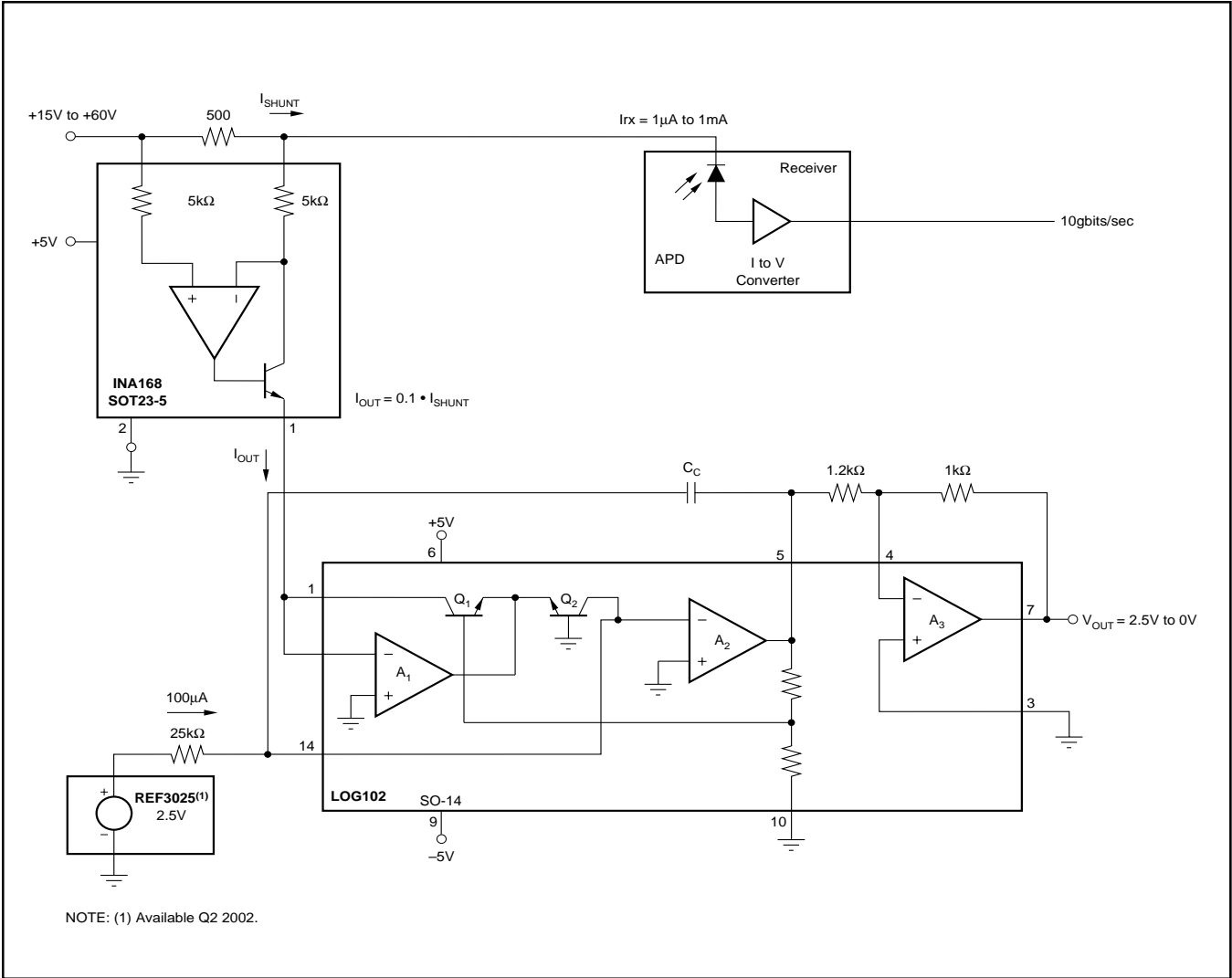

FIGURE 12. Technique for Using Full-Scale Reference Current such that V_{OUT} Increases with Increasing Photodiode Current.



NOTE: (1) Available Q2 2002.

FIGURE 13. High Side Shunt for Avalanche Photodiode (APD) Measures 3 Decades of APD Current.

DEFINITION OF TERMS

TRANSFER FUNCTION

The ideal transfer function is:

$$V_{OUT} = 1V \cdot \log I_1/I_2 \quad (5)$$

Figure 14 shows the graphical representation of the transfer over valid operating range for the LOG102.

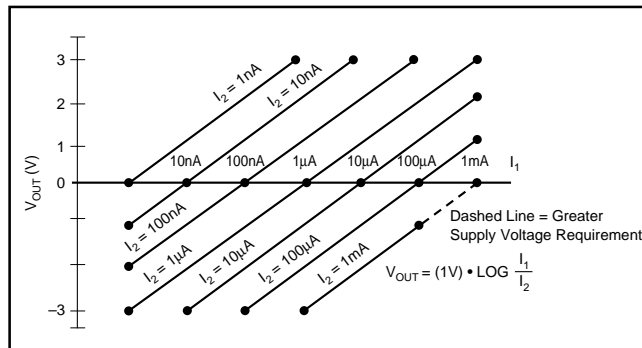

FIGURE 14. Transfer Function with Varying I_2 and I_1 .

ACCURACY

Accuracy considerations for a log ratio amplifier are somewhat more complicated than for other amplifiers. This is because the transfer function is nonlinear and has two inputs, each of which can vary over a wide dynamic range. The accuracy for any combination of inputs is determined from the total error specification.

TOTAL ERROR

The total error is the deviation (expressed in mV) of the actual output from the ideal output of $V_{OUT} = 1V \cdot \log(I_1/I_2)$.

Thus,

$$V_{OUT} (ACTUAL) = V_{OUT} (IDEAL) \pm \text{Total Error.} \quad (5)$$

It represents the sum of all the individual components of error normally associated with the log amp when operated in the current input mode. The worst-case error for any given ratio of I_1/I_2 is the largest of the two errors when I_1 and I_2 are considered separately; this case is shown in Table I. Temperature can affect total error.

I_2 (maximum error) ⁽¹⁾	I_1 (maximum error) ⁽¹⁾		
	10nA (30mV)	100nA (25mV)	1μA (20mV)
100nA (25mV)	30mV	25mV	25mV
1μA (20mV)	30mV	25mV	20mV
10μA (25mV)	30mV	25mV	25mV

NOTE: (1) Maximum errors are in parenthesis.

TABLE I. I_1/I_2 and Maximum Errors.

ERRORS RTO AND RTI

As with any transfer function, errors generated by the function itself may be Referred-to-Output (RTO) or Referred-to-Input (RTI). In this respect, log amps have a unique property:

Given some error voltage at the log amp's output, that error corresponds to a constant percent of the input regardless of the actual input level.

LOG CONFORMITY

For the LOG102, log conformity is calculated the same as linearity and is plotted I_1/I_2 on a semi-log scale. In many applications, log conformity is the most important specification. This is true because bias current errors are negligible (1pA compared to input currents of 1nA and above) and the scale factor and offset errors may be trimmed to zero or removed by system calibration. This leaves log conformity as the major source of error.

Log conformity is defined as the peak deviation from the best fit straight line of the V_{OUT} versus $\log(I_1/I_2)$ curve. This is expressed as a percent of ideal full-scale output. Thus, the nonlinearity error expressed in volts over m decades is:

$$V_{OUT} (NONLIN) = 1V/\text{dec} \cdot 2Nm \quad (6)$$

where N is the log conformity error, in percent.

INDIVIDUAL ERROR COMPONENTS

The ideal transfer function with current input is:

$$V_{OUT} = (1V) \cdot \log \frac{I_1}{I_2} \quad (7)$$

The actual transfer function with the major components of error is:

$$V_{OUT} = (1V) (1 \pm \Delta K) \log \frac{I_1 - I_{B1}}{I_2 - I_{B2}} \pm 2Nm \pm V_{OS OUT} \quad (8)$$

The individual component of error is:

ΔK = gain accuracy (0.3%, typ), as specified in specification table.

I_{B1} = bias current of A_1 (5pA, typ)

I_{B2} = bias current of A_2 (5pA, typ)

N = log conformity error (0.04%, 0.15%, typ)

0.04% for n = 5, 0.15% for n = 6

$V_{OS OUT}$ = output offset voltage (1mV, typ)

n = number of decades over which N is specified:

Example: what is the error when

$$I_1 = 1\mu A \text{ and } I_2 = 100nA \quad (9)$$

$$\approx 1.003 \log \frac{10^{-6}}{10^{-7}} + 0.004 + 0.003 \quad (10)$$

$$= 1.003 (1) + 0.004 + 0.0003 \quad (11)$$

$$= 1.0073V \quad (12)$$

Since the ideal output is 1.000V, the error as a percent of reading is

$$\% \text{ error} = \frac{0.0073}{1} \bullet 100\% = 0.73\% \quad (13)$$

For the case of voltage inputs, the actual transfer function is (14)

$$V_{OUT} = (1V)(1 \pm \Delta K) \log \frac{\frac{V_1 - I_{B1} \pm \frac{E_{OS1}}{R_1}}{\frac{V_2 - I_{B2} \pm \frac{E_{OS2}}{R_2}}{\pm 2Nn \pm V_{OS OUT}}}} \quad (15)$$

Where $\frac{E_{OS1}}{R_1}$ and $\frac{E_{OS2}}{R_2}$ are considered to be zero for large values of resistance from external input current sources.

PACKAGING INFORMATION

Orderable Device	Status (1)	Package Type	Package Drawing	Pins	Package Qty	Eco Plan (2)	Lead/Ball Finish (6)	MSL Peak Temp (3)	Op Temp (°C)	Device Marking (4/5)	Samples
LOG102AID	ACTIVE	SOIC	D	14	50	Green (RoHS & no Sb/Br)	CU NIPDAU	Level-3-260C-168 HR	0 to 70	LOG102A	Samples
LOG102AIDG4	ACTIVE	SOIC	D	14	50	Green (RoHS & no Sb/Br)	CU NIPDAU	Level-3-260C-168 HR	0 to 70	LOG102A	Samples
LOG102AIDR	ACTIVE	SOIC	D	14	2500	Green (RoHS & no Sb/Br)	CU NIPDAU	Level-3-260C-168 HR	0 to 70	LOG102A	Samples

(1) The marketing status values are defined as follows:

ACTIVE: Product device recommended for new designs.

LIFEBUY: TI has announced that the device will be discontinued, and a lifetime-buy period is in effect.

NRND: Not recommended for new designs. Device is in production to support existing customers, but TI does not recommend using this part in a new design.

PREVIEW: Device has been announced but is not in production. Samples may or may not be available.

OBSELETE: TI has discontinued the production of the device.

(2) Eco Plan - The planned eco-friendly classification: Pb-Free (RoHS), Pb-Free (RoHS Exempt), or Green (RoHS & no Sb/Br) - please check <http://www.ti.com/productcontent> for the latest availability information and additional product content details.

TBD: The Pb-Free/Green conversion plan has not been defined.

Pb-Free (RoHS): TI's terms "Lead-Free" or "Pb-Free" mean semiconductor products that are compatible with the current RoHS requirements for all 6 substances, including the requirement that lead not exceed 0.1% by weight in homogeneous materials. Where designed to be soldered at high temperatures, TI Pb-Free products are suitable for use in specified lead-free processes.

Pb-Free (RoHS Exempt): This component has a RoHS exemption for either 1) lead-based flip-chip solder bumps used between the die and package, or 2) lead-based die adhesive used between the die and leadframe. The component is otherwise considered Pb-Free (RoHS compatible) as defined above.

Green (RoHS & no Sb/Br): TI defines "Green" to mean Pb-Free (RoHS compatible), and free of Bromine (Br) and Antimony (Sb) based flame retardants (Br or Sb do not exceed 0.1% by weight in homogeneous material)

(3) MSL, Peak Temp. - The Moisture Sensitivity Level rating according to the JEDEC industry standard classifications, and peak solder temperature.

(4) There may be additional marking, which relates to the logo, the lot trace code information, or the environmental category on the device.

(5) Multiple Device Markings will be inside parentheses. Only one Device Marking contained in parentheses and separated by a "~" will appear on a device. If a line is indented then it is a continuation of the previous line and the two combined represent the entire Device Marking for that device.

(6) Lead/Ball Finish - Orderable Devices may have multiple material finish options. Finish options are separated by a vertical ruled line. Lead/Ball Finish values may wrap to two lines if the finish value exceeds the maximum column width.

Important Information and Disclaimer: The information provided on this page represents TI's knowledge and belief as of the date that it is provided. TI bases its knowledge and belief on information provided by third parties, and makes no representation or warranty as to the accuracy of such information. Efforts are underway to better integrate information from third parties. TI has taken and

continues to take reasonable steps to provide representative and accurate information but may not have conducted destructive testing or chemical analysis on incoming materials and chemicals. TI and TI suppliers consider certain information to be proprietary, and thus CAS numbers and other limited information may not be available for release.

In no event shall TI's liability arising out of such information exceed the total purchase price of the TI part(s) at issue in this document sold by TI to Customer on an annual basis.

TAPE AND REEL INFORMATION



QUADRANT ASSIGNMENTS FOR PIN 1 ORIENTATION IN TAPE



*All dimensions are nominal

Device	Package Type	Package Drawing	Pins	SPQ	Reel Diameter (mm)	Reel Width W1 (mm)	A0 (mm)	B0 (mm)	K0 (mm)	P1 (mm)	W (mm)	Pin1 Quadrant
LOG102AIDR	SOIC	D	14	2500	330.0	16.4	6.5	9.0	2.1	8.0	16.0	Q1

TAPE AND REEL BOX DIMENSIONS



*All dimensions are nominal

Device	Package Type	Package Drawing	Pins	SPQ	Length (mm)	Width (mm)	Height (mm)
LOG102AIDR	SOIC	D	14	2500	367.0	367.0	38.0

D (R-PDSO-G14)

PLASTIC SMALL OUTLINE



- NOTES:
- A. All linear dimensions are in inches (millimeters).
 - B. This drawing is subject to change without notice.
 - Body length does not include mold flash, protrusions, or gate burrs. Mold flash, protrusions, or gate burrs shall not exceed 0.006 (0,15) each side.
 - Body width does not include interlead flash. Interlead flash shall not exceed 0.017 (0,43) each side.
 - E. Reference JEDEC MS-012 variation AB.

D (R-PDSO-G14)

PLASTIC SMALL OUTLINE



4211283-3/E 08/12

- NOTES:
- All linear dimensions are in millimeters.
 - This drawing is subject to change without notice.
 - Publication IPC-7351 is recommended for alternate designs.
 - Laser cutting apertures with trapezoidal walls and also rounding corners will offer better paste release. Customers should contact their board assembly site for stencil design recommendations. Refer to IPC-7525 for other stencil recommendations.
 - Customers should contact their board fabrication site for solder mask tolerances between and around signal pads.

IMPORTANT NOTICE

Texas Instruments Incorporated and its subsidiaries (TI) reserve the right to make corrections, enhancements, improvements and other changes to its semiconductor products and services per JESD46, latest issue, and to discontinue any product or service per JESD48, latest issue. Buyers should obtain the latest relevant information before placing orders and should verify that such information is current and complete. All semiconductor products (also referred to herein as "components") are sold subject to TI's terms and conditions of sale supplied at the time of order acknowledgment.

TI warrants performance of its components to the specifications applicable at the time of sale, in accordance with the warranty in TI's terms and conditions of sale of semiconductor products. Testing and other quality control techniques are used to the extent TI deems necessary to support this warranty. Except where mandated by applicable law, testing of all parameters of each component is not necessarily performed.

TI assumes no liability for applications assistance or the design of Buyers' products. Buyers are responsible for their products and applications using TI components. To minimize the risks associated with Buyers' products and applications, Buyers should provide adequate design and operating safeguards.

TI does not warrant or represent that any license, either express or implied, is granted under any patent right, copyright, mask work right, or other intellectual property right relating to any combination, machine, or process in which TI components or services are used. Information published by TI regarding third-party products or services does not constitute a license to use such products or services or a warranty or endorsement thereof. Use of such information may require a license from a third party under the patents or other intellectual property of the third party, or a license from TI under the patents or other intellectual property of TI.

Reproduction of significant portions of TI information in TI data books or data sheets is permissible only if reproduction is without alteration and is accompanied by all associated warranties, conditions, limitations, and notices. TI is not responsible or liable for such altered documentation. Information of third parties may be subject to additional restrictions.

Resale of TI components or services with statements different from or beyond the parameters stated by TI for that component or service voids all express and any implied warranties for the associated TI component or service and is an unfair and deceptive business practice. TI is not responsible or liable for any such statements.

Buyer acknowledges and agrees that it is solely responsible for compliance with all legal, regulatory and safety-related requirements concerning its products, and any use of TI components in its applications, notwithstanding any applications-related information or support that may be provided by TI. Buyer represents and agrees that it has all the necessary expertise to create and implement safeguards which anticipate dangerous consequences of failures, monitor failures and their consequences, lessen the likelihood of failures that might cause harm and take appropriate remedial actions. Buyer will fully indemnify TI and its representatives against any damages arising out of the use of any TI components in safety-critical applications.

In some cases, TI components may be promoted specifically to facilitate safety-related applications. With such components, TI's goal is to help enable customers to design and create their own end-product solutions that meet applicable functional safety standards and requirements. Nonetheless, such components are subject to these terms.

No TI components are authorized for use in FDA Class III (or similar life-critical medical equipment) unless authorized officers of the parties have executed a special agreement specifically governing such use.

Only those TI components which TI has specifically designated as military grade or "enhanced plastic" are designed and intended for use in military/aerospace applications or environments. Buyer acknowledges and agrees that any military or aerospace use of TI components which have **not** been so designated is solely at the Buyer's risk, and that Buyer is solely responsible for compliance with all legal and regulatory requirements in connection with such use.

TI has specifically designated certain components as meeting ISO/TS16949 requirements, mainly for automotive use. In any case of use of non-designated products, TI will not be responsible for any failure to meet ISO/TS16949.

Products

Audio	www.ti.com/audio
Amplifiers	amplifier.ti.com
Data Converters	dataconverter.ti.com
DLP® Products	www.dlp.com
DSP	dsp.ti.com
Clocks and Timers	www.ti.com/clocks
Interface	interface.ti.com
Logic	logic.ti.com
Power Mgmt	power.ti.com
Microcontrollers	microcontroller.ti.com
RFID	www.ti-rfid.com
OMAP Applications Processors	www.ti.com/omap
Wireless Connectivity	www.ti.com/wirelessconnectivity

Applications

Automotive and Transportation	www.ti.com/automotive
Communications and Telecom	www.ti.com/communications
Computers and Peripherals	www.ti.com/computers
Consumer Electronics	www.ti.com/consumer-apps
Energy and Lighting	www.ti.com/energy
Industrial	www.ti.com/industrial
Medical	www.ti.com/medical
Security	www.ti.com/security
Space, Avionics and Defense	www.ti.com/space-avionics-defense
Video and Imaging	www.ti.com/video

TI E2E Community

e2e.ti.com