

LQH5BPN100MT0#

" # " indicates a package specification code.



< List of part numbers with package codes >
LQH5BPN100MT0L , LQH5BPN100MT0K

Shape

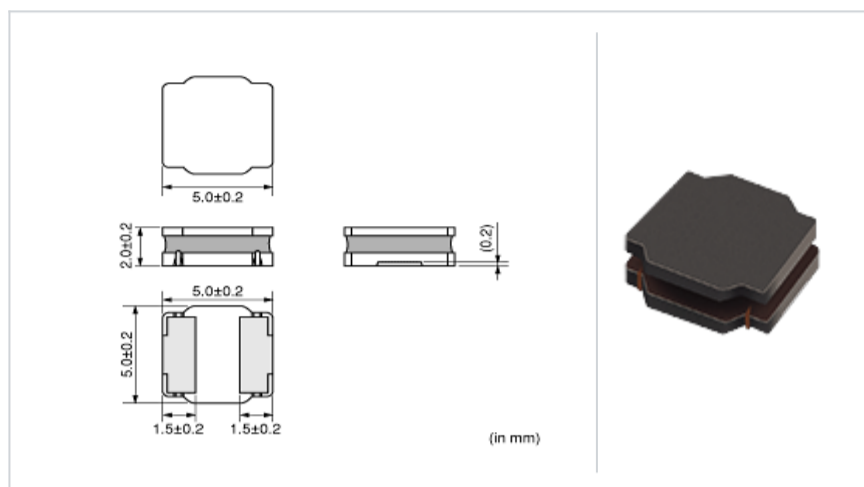

L size	5.0 ± 0.2mm
W size	5.0 ± 0.2mm
T size	2.0 ± 0.2mm
Size code in inch (mm)	2020 (5050)

Notes

When applied Rated current to the Products, Inductance will be within ± 30% of initial Inductance value.
When applied Rated current to the Products , self temperature rise shall be limited to 40 max.
Keep the temperature (ambient temperature plus self-generation o f heat) under 125

References

Packaging code	Specifications	Minimum quantity
L	180mm Embossed taping	500
K	330mm Embossed taping	3000

Mass (Typ.)	
1 piece	0.22g

Specifications

Inductance	10μH ± 20%
Inductance test frequency	100kHz
Rated current (Isat) (Based on Inductance change)	2.0A
Rated current (Itemp) (Based on Temperature rise)	1.60A
Max. of DC resistance	0.1272
Avg. of DC resistance	0.106 ± 20%
Self resonance frequency (min.)	25MHz
Operating temperature range (Self-temperature rise is included)	-40 ~ 125
Operating temperature range (Self-temperature rise is not included)	-40 ~ 85
Class of magnetic shield	Magnetic shield of magnetic powder in resin

Attention

- 1.This datasheet is downloaded from the website of Murata Manufacturing Co., Ltd. Therefore, it ' s specifications are subject to change or our products in it may be discontinued without advance notice. Please check with our sales representatives or product engineers before ordering.
- 2.This datasheet has only typical specifications because there is no space for detailed specifications.
Therefore, please review our product specifications or consult the approval sheet for product specifications before ordering.

Inductance-Frequency characteristics (Typ.)

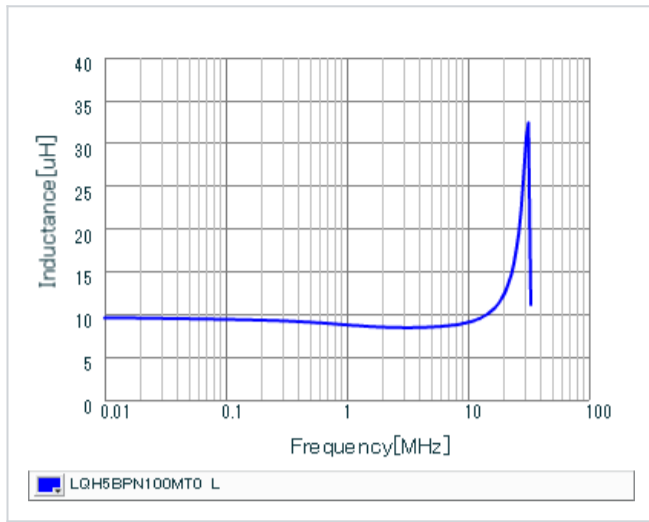

Inductance-Current characteristics (Typ.)

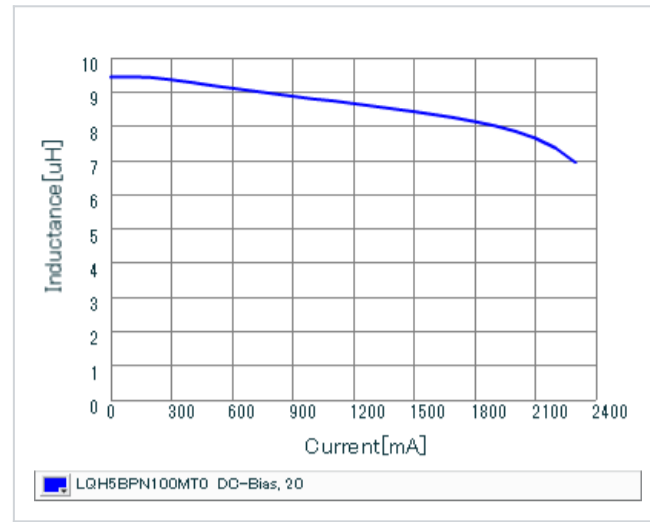

Temperature rise characteristics (Typ.)

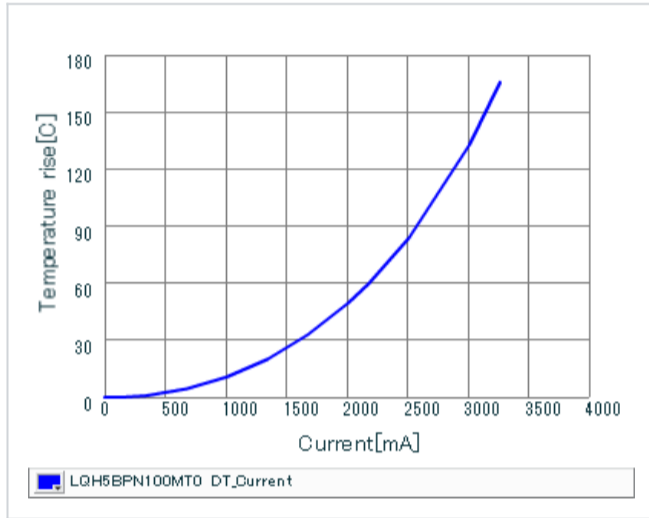

This PDF data has only typical specifications because there is no space for detailed specifications.

Therefore, please review our product specifications or consult the approval sheet for product specifications before ordering.