

# Parallel NOR Flash Embedded Memory

## M29W640FT, M29W640FB

### Features

- Supply voltage
  - $V_{CC}$  = 2.7–3.6V (program, erase, read)
  - $V_{PP}$  = 12V for fast program (optional)
- Asynchronous random/page read
  - Page width: 4 words
  - Page access: 25ns
  - Random access: 60ns, 70ns
- Program time
  - 10 $\mu$ s per byte/word TYP
  - 4 words/8 bytes program
- Memory organization
  - 135 memory blocks
  - 1 boot block and 7 parameter blocks, 8KB each (top or bottom)
  - 127 main blocks, 64KB each
- Program/erase controller
  - Embedded byte/word program algorithms
- Program/erase suspend and resume
  - Read from any block during a PROGRAM SUSPEND operation
  - Read or program another block during an ERASE SUSPEND operation
- UNLOCK BYPASS PROGRAM command
  - Faster production/batch programming
- $V_{PP}/WP\#$  pin for fast program and write protect
- Temporary block unprotection mode
- Common Flash interface
  - 64-bit security code
- Extended memory block
  - Extra block used as security block or to store additional information
- Low power consumption
  - Standby and automatic standby
- 100,000 PROGRAM/ERASE cycles per block
- Electronic signature
  - Manufacturer code: 0020h
  - Device code M29W640FT: 22EDh
  - Device code M29W640FB: 22FDh
- RoHS-compliant packages
  - 48-pin TSOP (N) 12mm x 20mm
  - 48-ball TFBGA (ZA) 6mm x 8mm

### Part Numbering Information

Available with extended memory block prelocked by Micron. Devices are shipped from the factory with memory content bits erased to 1. For available options, such as packages or speed, or for further information, contact your Micron sales representative. Part numbers can be verified at [www.micron.com](http://www.micron.com). Feature and specification comparison by device type is available at [www.micron.com/products](http://www.micron.com/products). Contact the factory for devices not found.

**Table 1: Part Number Information**

Part Number Category	Category Details
Device Type	M29 = Parallel Flash memory
Operating Voltage	W = $V_{CC}$ = 2.7 to 3.6V
Device Function	640F = 64Mb (x8/x16) boot block
Array Matrix	T = Top boot
	B = Bottom boot
Speed	60 = 60ns
	70 = 70ns

**Table 1: Part Number Information (Continued)**

<b>Part Number Category</b>	<b>Category Details</b>
Package	N = 48-pin TSOP: 12mm x 20mm
	ZA = 48-ball TFBGA, 6mm x 8mm, 0.80mm pitch
Temperature Range	6 = -40°C to 85°C
Shipping Options	E = RoHS-compliant package, standard packing
	F = RoHS-compliant package, tape and reel packing

## Contents

Important Notes and Warnings .....	7
General Description .....	8
Signal Assignments .....	10
Signal Descriptions .....	12
Memory Organization .....	15
Memory Configuration .....	15
x8 Memory Map – 64Mb Density .....	15
x16 Memory Map – 64Mb Density .....	17
Bus Operations .....	18
Read .....	18
Write .....	18
Standby and Automatic Standby .....	18
Output Disable .....	19
Status Register .....	20
Data Polling Bit (DQ7) .....	20
Toggle Bit (DQ6) .....	20
Error Bit (DQ5) .....	20
Erase Timer Bit (DQ3) .....	21
Alternative Toggle Bit (DQ2) .....	21
READ Operations .....	23
READ/RESET Command .....	23
READ CFI Command .....	24
AUTO SELECT Operations .....	25
AUTO SELECT Command .....	25
Command Interface .....	27
READ/RESET Command .....	27
AUTO SELECT Command .....	27
READ CFI QUERY Command .....	27
PROGRAM Command .....	28
PROGRAM SUSPEND Command .....	28
PROGRAM RESUME Command .....	29
Fast Program Commands .....	29
DOUBLE BYTE PROGRAM Command .....	29
QUADRUPLE BYTE PROGRAM Command .....	29
OCTUPLE BYTE PROGRAM Command .....	29
DOUBLE WORD PROGRAM Command .....	30
QUADRUPLE WORD PROGRAM Command .....	30
UNLOCK BYPASS Command .....	31
UNLOCK BYPASS PROGRAM Command .....	31
UNLOCK BYPASS RESET Command .....	31
CHIP ERASE Command .....	31
BLOCK ERASE Command .....	32
ERASE SUSPEND Command .....	32
ERASE RESUME Command .....	33
ENTER EXTENDED BLOCK Command .....	33
EXIT EXTENDED BLOCK Command .....	33
BLOCK PROTECT and CHIP UNPROTECT Commands .....	33
BLOCK PROTECT Command .....	33
Programmer Technique .....	34
In-System Technique .....	37



## 64Mb: 3V Embedded Parallel NOR Flash Features

Common Flash Interface .....	42
Absolute Ratings and Operating Conditions .....	46
DC Characteristics .....	48
Read AC Characteristics .....	49
Write AC Characteristics .....	52
Program/Erase Characteristics .....	56
Reset Characteristics .....	57
Package Dimensions .....	58
Revision History .....	60
Rev. C – 2/18 .....	60
Rev. B – 01/16 .....	60
Rev. A – 07/13 .....	60

## List of Figures

Figure 1: Logic Diagram .....	9
Figure 2: 48-Pin TSOP Pinout .....	10
Figure 3: 48-Ball TFBGA Ballout .....	11
Figure 4: Data Polling Flowchart .....	22
Figure 5: Data Toggle Flowchart .....	23
Figure 6: Programmer Equipment Block Protect Flowchart .....	35
Figure 7: Programmer Equipment Chip Unprotect Flowchart .....	36
Figure 8: In-System Equipment Block Protect Flowchart .....	38
Figure 9: In-System Equipment Chip Protect Flowchart .....	39
Figure 10: AC Measurement Load Circuit .....	47
Figure 11: AC Measurement I/O Waveform .....	47
Figure 12: Random AC Timing .....	50
Figure 13: Page Read AC Timing .....	51
Figure 14: WE#-Controlled AC Timing .....	53
Figure 15: CE#-Controlled AC Timing .....	55
Figure 16: Reset/block Temporary Unprotect AC Waveforms .....	57
Figure 17: Accelerated Program Timing Waveforms .....	57
Figure 18: 48-Pin TSOP – 12mm x 20mm .....	58
Figure 19: 48-Ball TFBGA – 6mm x 8mm .....	59

## List of Tables

Table 1: Part Number Information .....	1
Table 2: Signal Names .....	9
Table 3: Signal Descriptions .....	12
Table 4: Hardware Protection .....	14
Table 5: x8 Top Boot – Blocks [134:0] .....	15
Table 6: x8 Bottom Boot – Blocks [134:0] .....	15
Table 7: x16 Top Boot – Blocks [134:0] .....	17
Table 8: x16 Bottom Boot – Blocks [134:0] .....	17
Table 9: Bus Operations .....	18
Table 10: Status Register Bits .....	21
Table 11: Read Electronic Signature .....	25
Table 12: Block Protection .....	26
Table 13: Programmer Technique Bus Operations .....	37
Table 14: Commands – 16-Bit Mode (BYTE# = V <sub>IH</sub> ) .....	40
Table 15: Commands – 8-Bit Mode (BYTE# = V <sub>IL</sub> ) .....	41
Table 16: Query Structure Overview .....	42
Table 17: CFI Query Identification String .....	42
Table 18: CFI Query System Interface Information .....	43
Table 19: Device Geometry Definition .....	43
Table 20: Primary Algorithm-Specific Extended Query Table .....	44
Table 21: Security Code Area .....	45
Table 22: Absolute Maximum/Minimum Ratings .....	46
Table 23: Operating Conditions .....	46
Table 24: Input/Output Capacitance .....	47
Table 25: DC Current Characteristics .....	48
Table 26: DC Voltage Characteristics .....	48
Table 27: Read AC Characteristics .....	49
Table 28: WE#-Controlled Write AC Characteristics .....	52
Table 29: CE#-Controlled Write AC Characteristics .....	54
Table 30: Program/Erase Times and Endurance Cycles .....	56
Table 31: Reset/Block Temporary Unprotect AC Characteristics .....	57

## Important Notes and Warnings

Micron Technology, Inc. ("Micron") reserves the right to make changes to information published in this document, including without limitation specifications and product descriptions. This document supersedes and replaces all information supplied prior to the publication hereof. You may not rely on any information set forth in this document if you obtain the product described herein from any unauthorized distributor or other source not authorized by Micron.

**Automotive Applications.** Products are not designed or intended for use in automotive applications unless specifically designated by Micron as automotive-grade by their respective data sheets. Distributor and customer/distributor shall assume the sole risk and liability for and shall indemnify and hold Micron harmless against all claims, costs, damages, and expenses and reasonable attorneys' fees arising out of, directly or indirectly, any claim of product liability, personal injury, death, or property damage resulting directly or indirectly from any use of non-automotive-grade products in automotive applications. Customer/distributor shall ensure that the terms and conditions of sale between customer/distributor and any customer of distributor/customer (1) state that Micron products are not designed or intended for use in automotive applications unless specifically designated by Micron as automotive-grade by their respective data sheets and (2) require such customer of distributor/customer to indemnify and hold Micron harmless against all claims, costs, damages, and expenses and reasonable attorneys' fees arising out of, directly or indirectly, any claim of product liability, personal injury, death, or property damage resulting from any use of non-automotive-grade products in automotive applications.

**Critical Applications.** Products are not authorized for use in applications in which failure of the Micron component could result, directly or indirectly in death, personal injury, or severe property or environmental damage ("Critical Applications"). Customer must protect against death, personal injury, and severe property and environmental damage by incorporating safety design measures into customer's applications to ensure that failure of the Micron component will not result in such harms. Should customer or distributor purchase, use, or sell any Micron component for any critical application, customer and distributor shall indemnify and hold harmless Micron and its subsidiaries, subcontractors, and affiliates and the directors, officers, and employees of each against all claims, costs, damages, and expenses and reasonable attorneys' fees arising out of, directly or indirectly, any claim of product liability, personal injury, or death arising in any way out of such critical application, whether or not Micron or its subsidiaries, subcontractors, or affiliates were negligent in the design, manufacture, or warning of the Micron product.

**Customer Responsibility.** Customers are responsible for the design, manufacture, and operation of their systems, applications, and products using Micron products. ALL SEMICONDUCTOR PRODUCTS HAVE INHERENT FAILURE RATES AND LIMITED USEFUL LIVES. IT IS THE CUSTOMER'S SOLE RESPONSIBILITY TO DETERMINE WHETHER THE MICRON PRODUCT IS SUITABLE AND FIT FOR THE CUSTOMER'S SYSTEM, APPLICATION, OR PRODUCT. Customers must ensure that adequate design, manufacturing, and operating safeguards are included in customer's applications and products to eliminate the risk that personal injury, death, or severe property or environmental damages will result from failure of any semiconductor component.

**Limited Warranty.** In no event shall Micron be liable for any indirect, incidental, punitive, special or consequential damages (including without limitation lost profits, lost savings, business interruption, costs related to the removal or replacement of any products or rework charges) whether or not such damages are based on tort, warranty, breach of contract or other legal theory, unless explicitly stated in a written agreement executed by Micron's duly authorized representative.

## General Description

The M29W640F is a 64Mb (8Mb x8 or 4Mb x16) nonvolatile memory that can be read, erased, and reprogrammed. These operations can be performed using a single low voltage (2.7–3.6V) supply. On power-up, the memory defaults to read mode.

The memory is divided into blocks that can be erased independently so that valid data can be preserved while old data is erased. Blocks can be protected in units of 256KB (typically, groups of four 64KB blocks), to prevent accidental PROGRAM or ERASE commands from modifying the memory. PROGRAM and ERASE commands are written to the command interface. An on-chip program/erase controller simplifies the process of programming or erasing the memory by taking care of all of the special operations that are required to update the memory contents. The end of a PROGRAM or ERASE operation can be detected and any error conditions identified. The command set required to control the memory is consistent with JEDEC standards.

The device features an asymmetrical blocked architecture. The device has an array of 135 blocks: 8 parameter blocks of 8KB each (or 4 K words each) and 127 main blocks of 64KB each (or 32K words each)

M29W640FT contains the parameter blocks at the top of the memory address space. The M29W640FB contains the parameter blocks starting from the bottom.

The M29W640F has an extra block, the extended block, of 128 words in x16 mode, or of 256 bytes in x8 mode, that can be accessed using a dedicated command. The extended block can be protected. It is useful for storing security information. However, the protection is not reversible. Once protected, the protection cannot be undone.

CE#, OE#, and WE# signals control the bus operation of the memory. They enable simple connection to most microprocessors, often without additional logic.

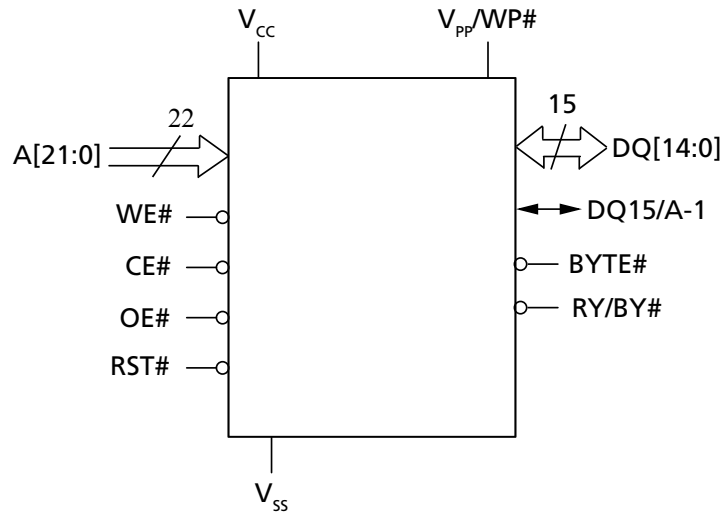
V<sub>pp</sub>/WP enables faster programming of the device, enabling multiple word/byte programming. If this signal is held at V<sub>SS</sub>, the boot block and its adjacent parameter block are protected from PROGRAM and ERASE operations.

The device supports asynchronous random read and page read from all blocks of the memory array.

In order to meet environmental requirements, Micron offers the M29W640FT and the M29W640FB in RoHS packages (lead-free). The category of second-level interconnect is marked on the package and on the inner box label, in compliance with JEDEC-Standard JESD97. The maximum ratings related to soldering conditions are also marked on the inner box label.

The memory is delivered with all the bits erased (set to 1).

**Figure 1: Logic Diagram**

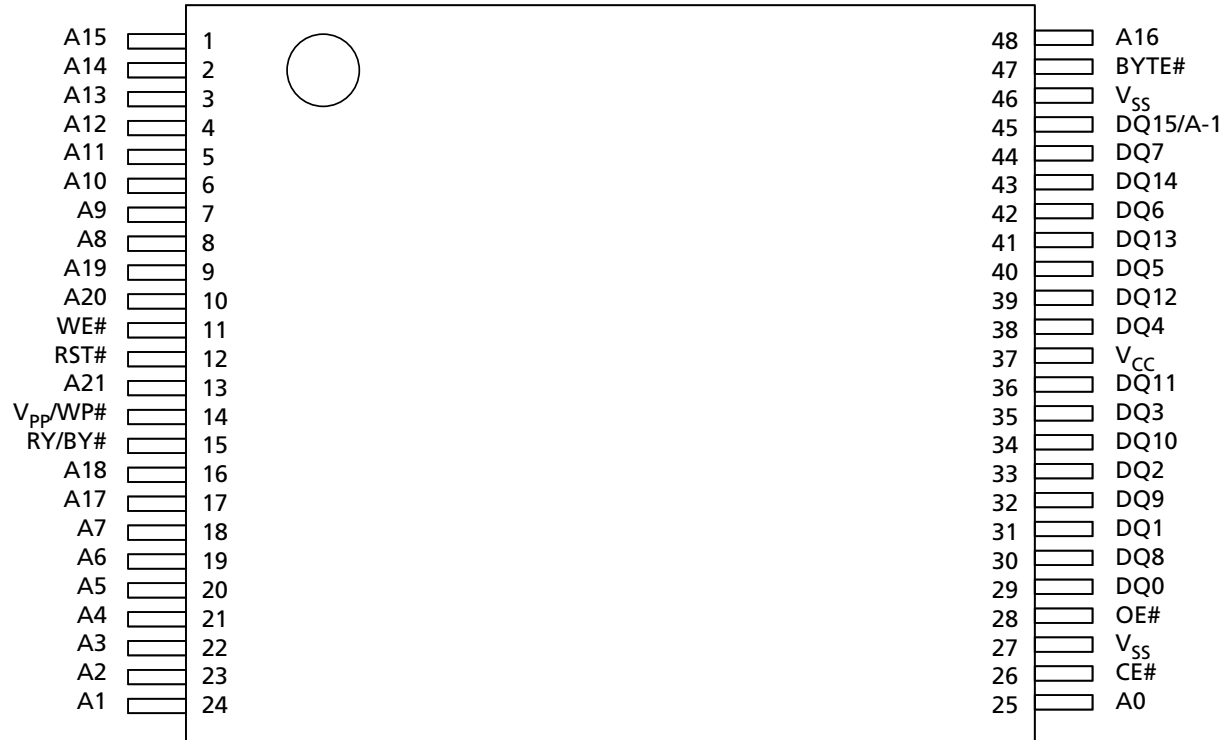


**Table 2: Signal Names**

Name	Type	Description
A[21:0]	Input	Address inputs
CE#	Input	Chip enable
OE#	Input	Output enable
WE#	Input	Write enable
RST#	Input	Reset/block temporary unprotect
RY/BY#	Input	Ready/busy
BYTE#	Input	Byte/word organization select
DQ[7:0]	I/O	Data input/outputs
DQ[14:8]	I/O	Data input/outputs
DQ15A-1 (or DQ15)	I/O	Data input/output or address input (or data I/O)
V <sub>CC</sub>	Supply voltage	Supply voltage
V <sub>PP</sub> /WP#	Supply voltage	Supply voltage for FAST PROGRAM (optional) or WRITE PROTECT operations
V <sub>SS</sub>	–	Ground
NC	–	Not connected internally

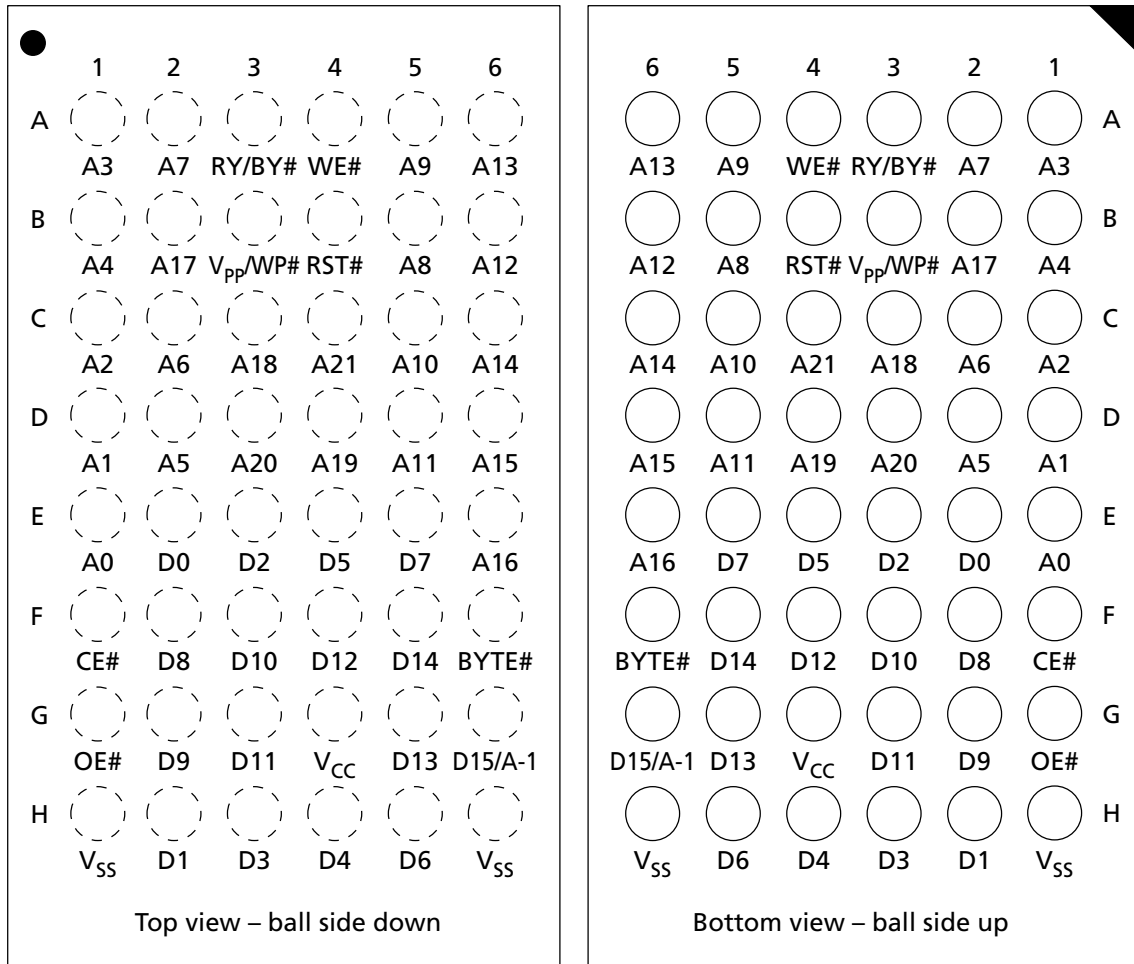
## Signal Assignments

Figure 2: 48-Pin TSOP Pinout



Note: 1. RFU = reserved for future use.

**Figure 3: 48-Ball TFBGA Ballout**



Note: 1. RFU = reserved for future use.

## Signal Descriptions

The signal description table below is a comprehensive list of signals for this device family. All signals listed may not be supported on this device. See Signal Assignments for information specific to this device.

**Table 3: Signal Descriptions**

Name	Type	Description
A[MAX:0]	Input	<b>Address:</b> Select the cells in the memory array to access during bus READ operations. During bus WRITE operations they control the commands sent to the command interface of the program/erase controller.
CE#	Input	<b>Chip enable:</b> Activates the memory, allowing bus READ and bus WRTE operations to be performed. When CE# is HIGH, all other pins are ignored.
OE#	Input	<b>Output enable:</b> Controls the bus READ operation of the memory.
WE#	Input	<b>Write enable:</b> Controls the bus write operation of the memory's command interface.
V <sub>pp</sub> /WP#	Input	<p><b>V<sub>pp</sub>/WP#:</b> Provides two functions: V<sub>pp</sub> enables the memory to use an external high-voltage power supply to reduce the time required for UNLOCK BYPASS PROGRAM operations. WP# performs hardware protection by protection the last block at the end of the addressable area (M29W640GH) or the first block at the beginning of the addressable area (M29W640GL). It protects the last two blocks at the end of the addressable area (M29W640GT) and the first two boot blocks at the beginning of the addressable area (M29W640GB).</p> <p>V<sub>pp</sub>/WP# may be left floating or unconnected (see DC Characteristics). When V<sub>pp</sub>/WP# is LOW, the last or first block in the M29W640GH and M29W640GL, respectively, and the last or first two blocks in the M29W640GT and M29W640GB, respectively, are protected. PROGRAM and ERASE operations in this block are ignored while V<sub>pp</sub>/WP# is LOW, even when RST# is at V<sub>ID</sub>.</p> <p>When V<sub>pp</sub>/WP# is HIGH, V<sub>IH</sub>, the device reverts to the previous protection status of the outermost blocks. PROGRAM and ERASE operations can now modify the data in the outermost blocks unless the block is protected using block protection.</p> <p>Applying 12V to V<sub>pp</sub>/WP# will temporarily unprotect any block previously protected (including the outermost blocks) using a high-voltage block protection technique (in-system or programmer technique). (See Hardware Protection for details. When V<sub>pp</sub>/WP# is raised to V<sub>pp</sub>, the device automatically enters the unlock bypass mode. When V<sub>pp</sub>/WP# returns to V<sub>IH</sub> or V<sub>IL</sub>, normal operation resumes. During UNLOCK BYPASS PROGRAM operations, the device draws I<sub>pp</sub> from the pin to supply the programming circuits. (See UNLOCK BYPASS Command.) The transitions from V<sub>IH</sub> to V<sub>pp</sub> and from V<sub>pp</sub> to V<sub>IH</sub> must be slower than t<sub>VHVPP</sub> (See the Accelerated Program Timing waveforms).</p> <p>Never raise V<sub>pp</sub>/WP# to V<sub>pp</sub> from any mode except read mode; otherwise, the device may be left in an indeterminate state.</p> <p>A 0.1µF capacitor should be connected between V<sub>pp</sub>/WP# and the V<sub>SS</sub> ground pin to decouple the current surges from the power supply. The PCB track widths must be sufficient to carry the currents required during an UNLOCK BYPASS PROGRAM operation, I<sub>pp</sub>.</p>

**Table 3: Signal Descriptions (Continued)**

Name	Type	Description
RST#	Input	<p><b>Reset/Block temporary unprotect:</b> Applies a hardware reset to the memory or temporarily unprotect all blocks that have been protected.</p> <p>Note that if <math>V_{PP}/WP</math> is at <math>V_{IL}</math>, then the last and the first block in the M29W640GH and M29W640GL, respectively, and the last two and first two blocks in the M29W640GT and M29W640GB, respectively, will remain protected, even if RST# is at <math>V_{ID}</math>.</p> <p>A hardware reset is achieved by holding RST# LOW for at least <math>t_{PLPX}</math>. After RST# goes HIGH, the memory will be ready for bus READ and bus WRITE operations after <math>t_{PHL}</math> or <math>t_{RHL}</math>, whichever occurs last. (See Reset Characteristics for more details.)</p> <p>Holding RST# at <math>V_{ID}</math> will temporarily unprotect the protected blocks in the memory. PROGRAM and ERASE operations on all blocks will be possible. The transition from <math>V_{IH}</math> to <math>V_{ID}</math> must be slower than <math>t_{PHPHH}</math>.</p>
DQ15/A-1	I/O	<p><b>Data I/O or address input:</b> When HIGH, behaves as a data I/O pin (as DQ8–DQ14). When LOW, behaves as an address pin; DQ15A–1 LOW will select the LSB of the addressed word; DQ15A–1 HIGH will select the MSB. Throughout the text, consider references to the data I/O to include this pin when BYTE# is HIGH and references to the address inputs to include this pin when BYTE# is LOW, except when stated explicitly otherwise.</p>
DQ[14:8]	I/O	<p><b>Data I/O:</b> Outputs the data stored at the selected address during a bus READ operation when BYTE# is HIGH. When BYTE# is LOW, these pins are not used and are High-Z. During bus WRITE operations, the command register does not use these bits. When reading the status register these bits should be ignored.</p>
DQ[7:0]	I/O	<p><b>Data I/O:</b> Outputs the data stored at the selected address during a bus READ operation. During bus WRITE operations, they represent the commands sent to the command interface of the program/erase controller.</p>
RY/BY#	Output	<p><b>Ready busy:</b> Open-drain output that identifies when the device is performing a PROGRAM or ERASE operation. During PROGRAM or ERASE operations, RY/BY# is LOW, and is High-Z during read mode, auto select mode, and erase suspend mode.</p> <p>After a hardware reset, bus READ and WRITE operations cannot begin until RY/BY# becomes High-Z. (See Reset Characteristics for more details.)</p> <p>The use of an open-drain output enables RY/BY# pins from several devices to be connected to a single pull-up resistor. A LOW will then indicate that one, or more, of the devices is busy.</p>
BYTE#	Input	<p><b>BYTE#/Word organization select:</b> Switches between the x8 and x16 bus modes of the device. When LOW, the device is in x8 mode; when HIGH, it is in x16 mode.</p>
$V_{CC}$	Supply	<p><b>Supply voltage:</b> Provides the power supply for all operations (READ, PROGRAM, and ERASE).</p> <p>The command interface is disabled when the <math>V_{CC}</math> supply voltage is less than the lockout voltage, <math>V_{LKO}</math>. This prevents bus WRITE operations from accidentally damaging the data during power-up, power-down, and power surges. If the program/erase controller is programming or erasing during this time, then the operation aborts and the memory contents being altered will be invalid.</p> <p>A 0.1 <math>\mu F</math> capacitor should be connected between the <math>V_{CC}</math> supply voltage pin and the <math>V_{SS}</math> ground pin to decouple the current surges from the power supply. The PCB track widths must be sufficient to carry the currents required during PROGRAM and ERASE operations, <math>I_{CC3}</math>.</p>

**Table 3: Signal Descriptions (Continued)**

Name	Type	Description
$V_{SS}$	Supply	<b>Ground:</b> Reference for all voltage measurements. The device features two $V_{SS}$ pins which must be both connected to the system ground.
RFU	–	<b>Reserved for future use:</b> RFUs should be not connected.

**Table 4: Hardware Protection**

$V_{PP}/WP\#$	RST#	Function
$V_{IL}$	$V_{IH}$	Two outermost parameter blocks protected from PROGRAM or ERASE operations
	$V_{ID}$	All blocks unprotected temporarily except the two outermost blocks
$V_{IH}$ or $V_{ID}$	$V_{ID}$	All blocks unprotected temporarily
$V_{PPH}$	$V_{IH}$ or $V_{ID}$	All blocks unprotected temporarily

## Memory Organization

### Memory Configuration

The main memory array is divided into 64KB blocks.

The blocks in the memory are asymmetrically arranged. The first or last 64KB of memory has been divided into eight 8KB parameter blocks.

### x8 Memory Map – 64Mb Density

**Table 5: x8 Top Boot – Blocks [134:0]**

Block	Block Size	Address Range		Notes
		Start	End	
134	8KB	007F E000	007F FFFF	1
133	8KB	007F C000	007F DFFF	
132	8KB	007F A000	007F BFFF	
131	8KB	007F 8000	007F 9FFF	
130	8KB	007F 6000	007F 7FFF	
129	8KB	007F 4000	007F 5FFF	
128	8KB	007F 2000	007F 3FFF	
127	8KB	007F 0000	007F 1FFF	
126	64KB	007E 0000	007E FFFF	
⋮	⋮	⋮	⋮	
2	64KB	0002 0000	0002 FFFF	
1	64KB	0001 0000	0001 FFFF	
0	64KB	0000 0000	0000 FFFF	

Note: 1. Used as the extended block addresses when the device is in extended block mode.

**Table 6: x8 Bottom Boot – Blocks [134:0]**

Block	Block Size	Address Range		Notes
		Start	End	
134	64KB	007F 0000	007F FFFF	
133	64KB	007E 0000	007E FFFF	
132	64KB	007D 0000	007D FFFF	
⋮	⋮	⋮	⋮	
8	64KB	0001 0000	0001 FFFF	



Table 6: x8 Bottom Boot – Blocks [134:0] (Continued)

Block	Block Size	Address Range		Notes
		Start	End	
7	8KB	0000 E000	0000 FFFF	1
6	8KB	0000 C000	0000 DFFF	
5	8KB	0000 A000	0000 BFFF	
4	8KB	0000 8000	0000 9FFF	
3	8KB	0000 6000	0000 7FFF	
2	8KB	0000 4000	0000 5FFF	
1	8KB	0000 2000	0000 3FFF	
0	8KB	0000 0000	0000 1FFF	

Note: 1. Used as the extended block addresses when the device is in extended block mode.



**x16 Memory Map – 64Mb Density**

**Table 7: x16 Top Boot – Blocks [134:0]**

Block	Block Size	Address Range		Notes
		Start	End	
134	8KW	003F F000	003F FFFF	1
133	8KW	003F E000	003F EFFF	
132	8KW	003F D000	003F DFFF	
131	8KW	003F C000	003F CFFF	
130	8KW	003F B000	003F BFFF	
129	8KW	003F A000	003F AFFF	
128	8KW	003F 9000	003F 9FFF	
127	8KW	003F 8000	003F 8FFF	
126	32KW	003F 0000	003F 7FFF	
⋮	⋮	⋮	⋮	
2	32KW	0001 0000	0001 7FFF	
1	32KW	0000 8000	0000 FFFF	
0	32KW	0000 0000	0000 7FFF	

Note: 1. Used as the extended block addresses when the device is in extended block mode.

**Table 8: x16 Bottom Boot – Blocks [134:0]**

Block	Block Size	Address Range		Notes
		Start	End	
134	32KW	003F 8000	003F FFFF	
133	32KW	003F 0000	003F 7FFF	
132	32KW	003E 8000	003E FFFF	
⋮	⋮	⋮	⋮	
8	32KW	0000 8000	000F FFFF	
7	8KW	0000 7000	0007 7FFF	1
6	8KW	0000 6000	0006 6FFF	
5	8KW	0000 5000	0005 5FFF	
4	8KW	0000 4000	0004 4FFF	
3	8KW	0000 3000	0003 3FFF	
2	8KW	0000 2000	0002 2FFF	
1	8KW	0000 1000	0001 1FFF	
0	8KW	0000 0000	0000 7FFF	

Note: 1. Used as the extended block addresses when the device is in extended block mode.

## Bus Operations

**Table 9: Bus Operations**

Notes 1 and 2 apply to entire table

Operation	CE#	OE#	WE#	8-Bit Mode			16-Bit Mode	
				A[MAX:0], DQ15/A-1	DQ[14:8]	DQ[7:0]	A[MAX:0]	DQ15/A-1, DQ[14:0]
READ	L	L	H	Cell address	High-Z	Data output	Cell address	Data output
WRITE	L	H	L	Command address	High-Z	Data input <sup>4</sup>	Command address	Data input <sup>4</sup>
STANDBY	H	X	X	X	High-Z	High-Z	X	High-Z
OUTPUT DISABLE	X	H	H	X	High-Z	High-Z	X	High-Z

- Notes:
1. Typical glitches of less than 5ns on CE# and WE# are ignored by the device and do not affect bus operations.
  2. H = Logic level HIGH ( $V_{IH}$ ); L = Logic level LOW ( $V_{IL}$ ); X = HIGH or LOW.
  3. If WP# = LOW, the highest/lowest block remains protected, depending on the line item.
  4. Data input is required when issuing a command sequence or performing data polling or block protection.

### Read

Bus READ operations read from the memory cells, registers, or CFI space. A valid READ operation requires setting the appropriate address on the address inputs, taking CE# and OE# LOW and holding WE# HIGH. Data I/O signals output the value.

### Write

Bus WRITE operations write to the command interface. A valid WRITE operation requires setting the appropriate address on the address inputs. These are latched by the command interface on the falling edge of CE# or WE#, whichever occurs last. Values on data I/O signals are latched by the command interface on the rising edge of CE# or WE#, whichever occurs first. OE# must remain HIGH during the entire operation.

### Standby and Automatic Standby

When the device is in read mode, driving CE# HIGH places the device in standby mode and drives data I/Os to High-Z. Supply current is reduced to standby ( $I_{CC2}$ ), by holding CE# within  $V_{CC} \pm 0.2V$ .

During PROGRAM or ERASE operations, the device continues to use the program/erase supply current ( $I_{CC3}$ ) until the operation completes.

Automatic standby enables low power consumption during read mode. When CMOS levels ( $V_{CC} \pm 0.2V$ ) drive the bus, and following a READ operation and a period of inactivity specified in DC Characteristics, the memory enters automatic standby as internal supply current is reduced to  $I_{CC2}$ . Data I/O signals still output data if a READ operation is in progress.



**Output Disable**

Data I/Os are High-Z when OE# is HIGH.

## Status Register

Bus READ operations from any address always read the status register during PROGRAM and ERASE operations. It is also read during ERASE SUSPEND operations when an address within a block being erased is accessed. The bits in the status register are summarized in the Status Register Bits table.

### Data Polling Bit (DQ7)

The data polling bit can be used to identify whether the program/erase controller has successfully completed its operation or if it has responded to an ERASE SUSPEND operation. The data polling bit is output on DQ7 when the status register is read.

During PROGRAM operations, the data polling bit outputs the complement of the bit being programmed to DQ7. After successful completion of the PROGRAM operation, the memory returns to read mode, and bus READ operations from the address just programmed output DQ7, not its complement.

During ERASE operations, the data polling bit outputs 0, the complement of the erased state of DQ7. After successful completion of the ERASE operation, the memory returns to read mode.

In erase suspend mode, the data polling bit will output a 1 during a bus READ operation within a block being erased. The data polling bit will change from a 0 to a 1 when the program/erase controller has suspended the ERASE operation. The Data Polling Flowchart gives an example of how to use the data polling bit. A valid address is the address being programmed or an address within the block being erased.

### Toggle Bit (DQ6)

The toggle bit can be used to identify whether the program/erase controller has successfully completed its operation or if it has responded to an ERASE SUSPEND command. The toggle bit is output on DQ6 when the status register is read.

During PROGRAM and ERASE operations, the toggle bit changes from 0 to 1 to 0, etc., with successive bus READ operations at any address. After successful completion of the operation, the memory returns to read mode.

During erase suspend mode, the toggle bit will output when addressing a cell within a block being erased. The toggle bit will stop toggling when the program/erase controller has suspended the ERASE operation.

If any attempt is made to erase a protected block, the operation is aborted, no error is signaled, and DQ6 toggles for approximately 100 $\mu$ s. If any attempt is made to program a protected block or a suspended block, the operation is aborted, no error is signaled, and DQ6 toggles for approximately 1 $\mu$ s. The Data Toggle Flowchart gives an example of how to use the data toggle bit.

### Error Bit (DQ5)

The error bit can be used to identify errors detected by the program/erase controller. The error bit is set to 1 when a PROGRAM, BLOCK ERASE, or CHIP ERASE operation fails to write the correct data to the memory. If the error bit is set, a READ/RESET command must be issued before other commands are issued. The error bit is output on DQ5 when the status register is read.

Note that the PROGRAM command cannot change a bit set to 0 back to 1, and attempting to do so will set DQ5 to 1. A bus READ operation to that address will show the bit is still 0. One of the ERASE commands must be used to set all the bits in a block or in the whole memory from 0 to 1.

### Erase Timer Bit (DQ3)

The erase timer bit can be used to identify the start of program/erase controller operation during a BLOCK ERASE command. When the program/erase controller starts erasing, the erase timer bit is set to 1. Before the program/erase controller starts, the erase timer bit is set to 0, and additional blocks to be erased may be written to the command interface. The erase timer bit is output on DQ3 when the status register is read.

### Alternative Toggle Bit (DQ2)

The alternative toggle bit can be used to monitor the program/erase controller during ERASE operations. It is output on DQ2 when the status register is read.

During CHIP ERASE and BLOCK ERASE operations, the toggle bit changes from 0 to 1 to 0, etc., with successive bus READ operations from addresses within the blocks being erased. A protected block is treated the same as a block not being erased. After the operation completes, the memory returns to read mode.

During an ERASE SUSPEND operation, the alternative toggle bit changes from 0 to 1 to 0, etc., with successive bus READ operations from addresses within the blocks being erased. Bus READ operations to addresses within blocks not being erased will output the memory cell data as if in read mode.

After an ERASE operation that causes the error bit to be set, the alternative toggle bit can be used to identify which block or blocks have caused the error. The alternative toggle bit changes from 0 to 1 to 0, etc., with successive bus READ operations from addresses within blocks that have not erased correctly. The alternative toggle bit does not change if the addressed block has erased correctly.

**Table 10: Status Register Bits**

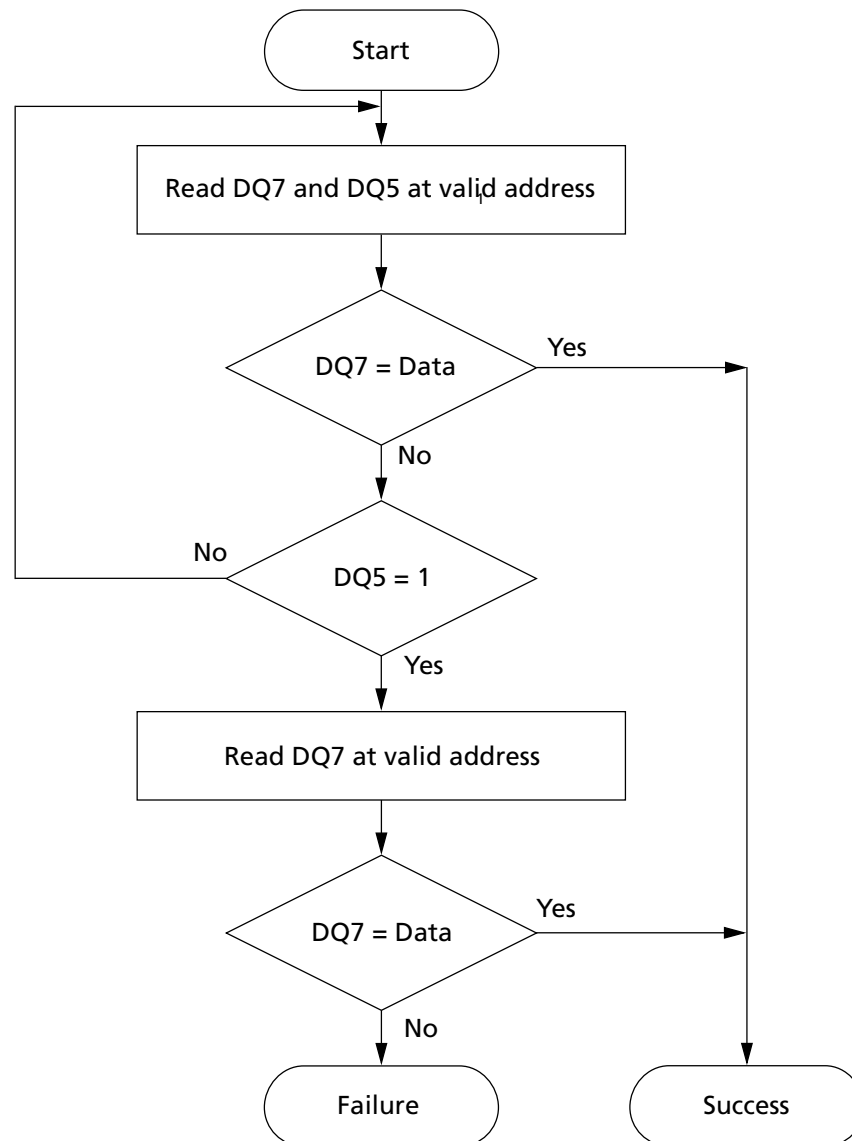
Operation	Address	DQ7	DQ6	DQ5	DQ3	DQ2	RY/BY#
PROGRAM	Any address	DQ7#	Toggle	0	–	–	0
PROGRAM DURING ERASE SUSPEND	Any address	DQ7#	Toggle	0	–	–	0
PROGRAM ERROR	Any address	DQ7#	Toggle	1	–	–	0
CHIP ERASE	Any address	0	Toggle	0	1	Toggle	0
BLOCK ERASE BEFORE TIMEOUT	Erasing block	0	Toggle	0	0	Toggle	0
	Non-erasing block	0	Toggle	0	0	No Toggle	0
BLOCK ERASE	Erasing block	0	Toggle	0	1	Toggle	0
	Non-erasing block	0	Toggle	0	1	No Toggle	0
ERASE SUSPEND	Erasing block	1	No Toggle	0	–	Toggle	1
	Non-erasing block	Data read as normal					

**Table 10: Status Register Bits (Continued)**

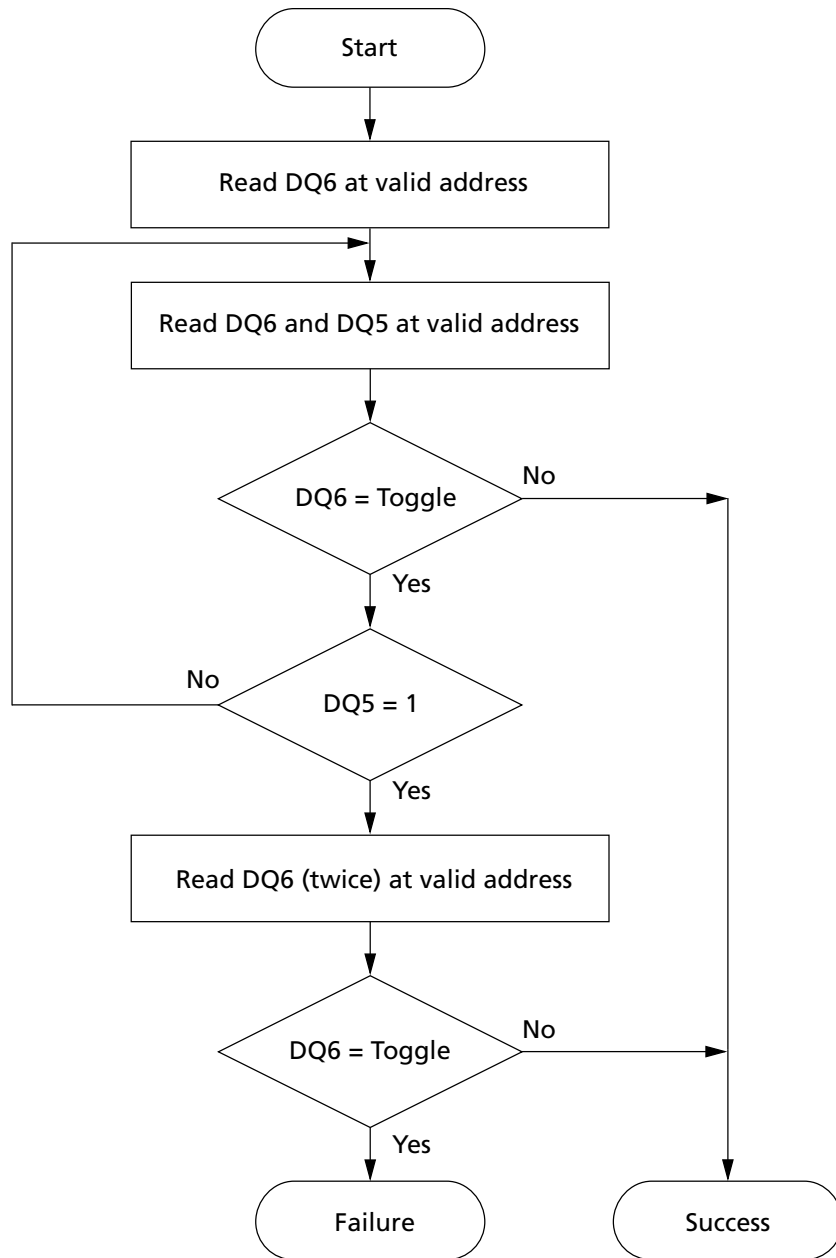
Operation	Address	DQ7	DQ6	DQ5	DQ3	DQ2	RY/BY#
ERASE ERROR	Good block address	0	Toggle	1	1	No Toggle	0
	Faulty block address	0	Toggle	1	1	Toggle	0

Note: 1. Unspecified data bits should be ignored.

**Figure 4: Data Polling Flowchart**



**Figure 5: Data Toggle Flowchart**



## READ Operations

### READ/RESET Command

The READ/RESET (F0h) command returns the device to read mode and resets the errors in the status register. One or three bus WRITE operations can be used to issue the READ/RESET command.

To return the device to read mode, this command can be issued between bus WRITE cycles before the start of a PROGRAM or ERASE operation. If the READ/RESET command is issued during the timeout of a BLOCK ERASE operation, the device requires up to 10 $\mu$ s to abort, during which time no valid data can be read.

### READ CFI Command

The READ CFI (98h) command puts the device in read CFI mode and is valid only when the device is in read array or auto select mode. One bus WRITE cycle is required to issue the command.

Once in read CFI mode, bus READ operations will output data from the CFI memory area. A READ/RESET command must be issued to return the device to the previous mode (read array or auto select ). A second READ/RESET command is required to put the device in read array mode from auto select mode.

## AUTO SELECT Operations

### AUTO SELECT Command

At power-up or after a hardware reset, the device is in read mode. It can then be put in auto select mode by issuing an AUTO SELECT (90h) command or by applying  $V_{ID}$  to A9. Auto select mode enables the following device information to be read:

- Electronic signature, which includes manufacturer and device code information.
- Block protection, which includes the block protection status and extended memory block protection indicator.

Electronic signature or block protection information is read by executing a READ operation with control signals and addresses set.

Auto select mode can be used by the programming equipment to automatically match a device with the application code to be programmed.

Three consecutive bus WRITE operations are required to issue an AUTO SELECT command. The device remains in auto select mode until a READ/RESET or READ CFI command is issued.

The device cannot enter auto select mode when a PROGRAM or ERASE operation is in progress (RY/BY# LOW). However, auto select mode can be entered if the PROGRAM or ERASE operation has been suspended by issuing a PROGRAM SUSPEND or ERASE SUSPEND command.

To enter auto select mode by applying  $V_{ID}$  to A9 (see the following tables).

Auto select mode is exited by performing a reset. The device returns to read mode unless it entered auto select mode after an ERASE SUSPEND or PROGRAM SUSPEND command, in which case it returns to erase or program suspend mode.

**Table 11: Read Electronic Signature**

Note 1 applies to entire table

Signal	READ Cycle						Notes
	Manufacturer Code	Device Code 1	Device Code 2		Device Code 3		
			GH/GL	GT/GB	GH/GT	GL/GB	
CE#	L	L	L	L	L	L	
OE#	L	L	L	L	L	L	
WE#	H	H	H	H	H	H	
<b>Address Input, 8-Bit and 16-Bit</b>							
A[MAX:10]	X	X	X	X	X	X	
A9	$V_{ID}$	$V_{ID}$	$V_{ID}$	$V_{ID}$	$V_{ID}$	$V_{ID}$	2
A8	X	X		X		X	
A[7:5]	L	L		L		L	
A4	X	X		X		X	
A[3:1]	L	L		H		H	
A0	L	H		L		H	
<b>Address Input, 8-Bit Only</b>							

**Table 11: Read Electronic Signature (Continued)**

Note 1 applies to entire table

Signal	READ Cycle						Notes
	Manufacturer Code	Device Code 1	Device Code 2		Device Code 3		
			GH/GL	GT/GB	GH/GT	GL/GB	
DQ[15]/A-1	X	X		X		X	
<b>Data I/O, 8-Bit Only</b>							
DQ[14:8]	X	X		X		X	
DQ[7:0]	20h	7Eh	0Ch	10h	01h	00h	
<b>Data I/O, 16-Bit Only</b>							
DQ[15]/A-1, and DQ[14:0]	0020h	227Eh	220Ch	2210h	2201h	2200h	

- Notes: 1. H = Logic level HIGH ( $V_{IH}$ ); L = Logic level LOW ( $V_{IL}$ ); X = HIGH or LOW.  
 2. When using the AUTO SELECT command to enter auto select mode, applying  $V_{ID}$  to A9 is not required. A9 can be either  $V_{IL}$  or  $V_{IH}$ .

**Table 12: Block Protection**

Note 1 applies to entire table

Operation	CE#	OE#	WE#	Address Input										Data I/O
				A[MAX]	A15	A[14:13]	A12	A[11:10], A[8:7], A[5:4]	A9	A6	A[3:2]	A1	A0	DQ15/A-1, DQ[14:0]
BLOCK PROTECT (Group)	L	$V_{ID}$	LP	Block address				X	$V_{ID}$	X				X
CHIP UNPROTECT	$V_{ID}$	$V_{ID}$	LP	X	H	X	H	X	$V_{ID}$	X				X
VERIFY BLOCK PROTECTION	L	L	H	Block address				X	$V_{ID}$	L	L	H	L	Pass = xx01h Retry = xx00h
VERIFY BLOCK UNPROTECT	L	L	H	Block address				X	$V_{ID}$	H	L	H	L	Retry = xx01h Pass = xx00h

- Note: 1. H = Logic level HIGH ( $V_{IH}$ ); L = Logic level LOW ( $V_{IL}$ ); LP = L pulse; X = HIGH or LOW.

## Command Interface

All bus WRITE operations to the memory are interpreted by the command interface. Commands consist of one or more sequential bus WRITE operations. Failure to observe a valid sequence of bus WRITE operations will result in the memory returning to read mode. The long command sequences are imposed to maximize data security.

The address used for the commands changes, depending on whether the memory is in 16-bit or 8-bit mode. See the x8 and x16 command tables, depending on the configuration that is being used, for a summary of the commands.

### READ/RESET Command

The READ/RESET command returns the memory to read mode. It also resets the errors in the status register. Either one or three bus WRITE operations can be used to issue the READ/RESET command.

The READ/RESET command can be issued, between bus WRITE cycles before the start of a PROGRAM or ERASE operation, to return the device to read mode. If the READ/RESET command is issued during the timeout of a BLOCK ERASE operation, then the device will take up to 10 $\mu$ s to abort. During the abort period, no valid data can be read from the device. The READ/RESET command will not abort an ERASE operation when issued while in erase suspend.

### AUTO SELECT Command

The AUTO SELECT command is used to read the manufacturer code, the device code, the block protection status, and the extended memory block verify code. Three consecutive bus WRITE operations are required to issue the AUTO SELECT command. After the AUTO SELECT command is issued, the memory remains in auto select mode until a READ/RESET command is issued. READ CFI QUERY and READ/RESET commands are accepted in auto select mode; all other commands are ignored.

In auto select mode, the manufacturer code and the device code can be read by using a bus READ operation with addresses and control signals set, as shown Bus Operations, except for A9 (which is "Don't Care").

The block protection status of each block can be read using a bus READ operation with addresses and control signals set, as shown in Bus Operations, except for A9 (which is "Don't Care"). If the addressed block is protected, then 01h is output on DQ0–DQ7; otherwise, 00h is output (in 8-bit mode).

The protection status of the extended memory block, or extended memory block verify code, can be read using a bus READ operation with addresses and control signals, except for A9 (which is "Don't Care"). If the extended block is "factory-locked," then 80h is output on DQ0–DQ7; otherwise, 00h is output (8-bit mode).

### READ CFI QUERY Command

The READ CFI QUERY command is used to read data from the CFI. This command is valid when the device is in the read array mode, or when the device is in auto select mode.

One bus WRITE cycle is required to issue the READ CFI QUERY command. After the command is issued, subsequent bus READ operations read from the CFI.

The READ/RESET command must be issued to return the device to the previous mode (the read array mode or auto select mode). A second READ/RESET command would be needed if the device is to be put in the read array mode from auto selected mode.

## **PROGRAM Command**

The PROGRAM command can be used to program a value to one address in the memory array at a time. The command requires four bus WRITE operations; the final WRITE operation latches the address and data, and starts the program/erase controller.

Programming can be suspended and then resumed by issuing a PROGRAM SUSPEND command and a PROGRAM RESUME command, respectively.

If the address falls in a protected block, then the PROGRAM command is ignored, the data remains unchanged. The status register is never read and no error condition is given.

During a PROGRAM operation, the memory will ignore all commands. It is not possible to issue any command to abort or pause the operation. Bus READ operations during the PROGRAM operation will output the status register on the data I/Os. (See Status Register for more details.)

After the PROGRAM operation has completed, the memory will return to the read mode, unless an error has occurred. When an error occurs, the memory will continue to output the status register. A READ/RESET command must be issued to reset the error condition and return to read mode.

Note that the PROGRAM command cannot change a bit set to 0 back to 1. One of the ERASE commands must be used to set all the bits in a block or in the whole memory from 0 to 1. (Refer to Program/Erase Characteristics.)

## **PROGRAM SUSPEND Command**

The PROGRAM SUSPEND command allows the system to interrupt a PROGRAM operation so that data can be read from any block. When the PROGRAM SUSPEND command is issued during a PROGRAM operation, the device suspends the PROGRAM operation within the program suspend latency time and updates the status register bits (see Program/Erase Characteristics).

After the PROGRAM operation has been suspended, the system can read array data from any address. However, data read from program-suspended addresses is not valid.

The PROGRAM SUSPEND command may also be issued during a PROGRAM operation while an erase is suspended. In this case, data may be read from any addresses not in ERASE SUSPEND or PROGRAM SUSPEND. If a read is needed from the extended block area (one-time program area), the user must use the proper command sequences to enter and exit this region.

The system may also issue the AUTO SELECT command sequence when the device is in the program suspend mode. The system can read as many auto select codes as required. When the device exits the auto select mode, the device reverts to the program suspend mode, and is ready for another valid operation.

## PROGRAM RESUME Command

After the PROGRAM RESUME command is issued, the device reverts to programming. The controller can determine the status of the PROGRAM operation using the DQ7 or DQ6 status bits, just as in the standard PROGRAM operation.

The system must write the PROGRAM RESUME command, to exit the program suspend mode and to continue the programming operation.

Further issuing of the RESUME command is ignored. Another PROGRAM SUSPEND command can be written after the device has resumed programming.

## Fast Program Commands

There are five fast program commands available to improve the programming throughput, by writing several adjacent words or bytes in parallel:

- QUADRUPLE and OCTUPLE BYTE PROGRAM, available for x8 operations
- DOUBLE and QUADRUPLE WORD PROGRAM, available for x16 operations

Fast program commands can be suspended and then resumed by issuing a PROGRAM SUSPEND command and a PROGRAM RESUME command, respectively.

To perform some of the fast program commands,  $V_{PPH}$  must be applied  $V_{PP}/WP\#$ . Note that doing so will temporarily unprotect any protected block.

## DOUBLE BYTE PROGRAM Command

The DOUBLE BYTE PROGRAM command is used to write a page of two adjacent bytes in parallel. The two bytes must differ only in DQ15A-1. Three bus WRITE cycles are necessary to issue the DOUBLE BYTE PROGRAM command:

The first bus cycle sets up the DOUBLE BYTE PROGRAM command; the second bus cycle latches the address and the data of the first byte to be written; and the third bus cycle latches the address and the data of the second byte to be written.

## QUADRUPLE BYTE PROGRAM Command

The QUADRUPLE BYTE PROGRAM command is used to write a page of four adjacent bytes in parallel. The four bytes must differ only for addresses A0, DQ15A-1. Five bus write cycles are necessary to issue the QUADRUPLE BYTE PROGRAM command:

The first bus cycle sets up the QUADRUPLE BYTE PROGRAM command; the second bus cycle latches the address and the data of the first byte to be written; the third bus cycle latches the address and the data of the second byte to be written; the fourth bus cycle latches the address and the data of the third byte to be written; and the fifth bus cycle latches the address and the data of the fourth byte to be written and starts the program/erase controller.

## OCTUPLE BYTE PROGRAM Command

This is used to write eight adjacent bytes, in x8 mode, simultaneously. The addresses of the eight bytes must differ only in A1, A0 and DQ15A-1.

12V must be applied to  $V_{PP}/WP\#$  prior to issuing an OCTUPLE BYTE PROGRAM command. Care must be taken because applying a 12V voltage to  $V_{PP}/WP\#$ , because it will temporarily unprotect any protected block.

Nine bus WRITE cycles are necessary to issue the command:

The first bus cycle sets up the command; the second bus cycle latches the address and the data of the first byte to be written; the third bus cycle latches the address and the data of the second byte to be written; the fourth bus cycle latches the address and the data of the third byte to be written, the fifth bus cycle latches the address and the data of the fourth byte to be written; the sixth bus cycle latches the address and the data of the fifth byte to be written; the seventh bus cycle latches the address and the data of the sixth byte to be written; the eighth bus cycle latches the address and the data of the seventh byte to be written; and the ninth bus cycle latches the address and the data of the eighth byte to be written and starts the program/erase controller.

### **DOUBLE WORD PROGRAM Command**

The DOUBLE WORD PROGRAM command is used to write a page of two adjacent words in parallel. The two words must differ only for the address A0.

Three bus WRITE cycles are necessary to issue the DOUBLE WORD PROGRAM command:

The first bus cycle sets up the DOUBLE WORD PROGRAM command; the second bus cycle latches the address and the data of the first word to be written; and the third bus cycle latches the address and the data of the second word to be written and starts the program/erase controller.

After the PROGRAM operation has completed, the memory will return to the read mode, unless an error has occurred. When an error occurs, bus READ operations will continue to output the status register. A READ/RESET command must be issued to reset the error condition and return to read mode.

Note that the fast program commands cannot change a bit set to 0 back to 1. One of the ERASE commands must be used to set all the bits in a block or in the whole memory from 0 to 1.

Typical program times are given in Program/Erase Characteristics.

**Note:** It is not necessary to raise  $V_{pp}/WP\#$  to 12V before issuing this command.

### **QUADRUPLE WORD PROGRAM Command**

This is used to write a page of four adjacent words (or 8 adjacent bytes), in x16 mode, simultaneously. The addresses of the four words must differ only in A1 and A0.

12V must be applied to  $V_{pp}/WP\#$  prior to issuing a QUADRUPLE BYTE PROGRAM command. Care must be taken because applying a 12V voltage to  $V_{pp}/WP\#$ , because it will temporarily unprotect any protected block.

Five bus WRITE cycles are necessary to issue the command:

The first bus cycle sets up the command; the second bus cycle latches the address and the data of the first word to be written; the third bus cycle latches the address and the data of the second word to be written; the fourth bus cycle latches the address and the data of the third word to be written; and the fifth bus cycle latches the address and the data of the fourth word to be written and starts the program/erase controller.

## **UNLOCK BYPASS Command**

The UNLOCK BYPASS command is used in conjunction with the UNLOCK BYPASS PROGRAM command to program the memory faster than with the standard PROGRAM commands. When the cycle time to the device is long, considerable time saving can be made by using these commands. Three bus WRITE operations are required to issue the UNLOCK BYPASS command.

After the UNLOCK BYPASS command has been issued, the memory will only accept the UNLOCK BYPASS PROGRAM command and the UNLOCK BYPASS RESET command. The memory can be read as if in read mode.

When  $V_{pp}$  is applied to  $V_{pp}/WP\#$ , the memory automatically enters the unlock bypass mode and the UNLOCK BYPASS PROGRAM command can be issued immediately.

## **UNLOCK BYPASS PROGRAM Command**

The UNLOCK BYPASS command is used in conjunction with the UNLOCK BYPASS PROGRAM command to program the memory. When the cycle time to the device is long, considerable time saving can be made by using these commands. Three bus WRITE operations are required to issue the UNLOCK BYPASS command.

After the UNLOCK BYPASS command has been issued, the memory will only accept the UNLOCK BYPASS PROGRAM command and the UNLOCK BYPASS RESET command. The memory can be read as if in read mode.

The memory offers accelerated PROGRAM operations through  $V_{pp}/WP\#$ . When the system asserts  $V_{pp}$  on  $V_{pp}/WP\#$ , the memory automatically enters the unlock bypass mode. The system may then write the two-cycle UNLOCK BYPASS PROGRAM command sequence. The memory uses the higher voltage on  $V_{pp}/WP\#$  to accelerate the UNLOCK BYPASS PROGRAM operation.

Never raise  $V_{pp}/WP\#$  to  $V_{pp}$  from any mode except read mode; otherwise, the memory may be left in an indeterminate state.

## **UNLOCK BYPASS RESET Command**

The UNLOCK BYPASS RESET command can be used to return to read/reset mode from unlock bypass mode. Two bus WRITE operations are required to issue the UNLOCK BYPASS RESET command. A READ/RESET command does not exit from unlock bypass mode.

## **CHIP ERASE Command**

The CHIP ERASE command can be used to erase the entire chip. Six bus WRITE operations are required to issue the CHIP ERASE command and start the program/erase controller.

If any blocks are protected, then these are ignored and all the other blocks are erased. If all of the blocks are protected the CHIP ERASE operation appears to start but will terminate within about 100 $\mu$ s, leaving the data unchanged. No error condition is given when protected blocks are ignored.

During the ERASE operation, the memory will ignore all commands, including the ERASE SUSPEND command. It is not possible to issue any command to abort the oper-

ation. All bus READ operations during the CHIP ERASE operation will output the status register on the data I/Os.

After the CHIP ERASE operation has completed, the memory will return to the read mode, unless an error has occurred. When an error occurs, the memory will continue to output the status register. A READ/RESET command must be issued to reset the error condition and return to read mode.

The CHIP ERASE command sets all of the bits in unprotected blocks of the memory to 1. All previous data is lost.

## **BLOCK ERASE Command**

The BLOCK ERASE command can be used to erase a list of one or more blocks. Six bus WRITE operations are required to select the first block in the list. Each additional block in the list can be selected by repeating the sixth bus WRITE operation using the address of the additional block. The BLOCK ERASE operation starts the program/erase controller about 50 $\mu$ s after the last bus WRITE operation. After the program/erase controller starts, it is not possible to select any more blocks. Each additional block must therefore be selected within 50 $\mu$ s of the last block. The 50 $\mu$ s timer restarts when an additional block is selected. The status register can be read after the sixth bus WRITE operation. ( See the status register section for details on how to identify whether the program/erase controller has started the BLOCK ERASE operation.)

If any selected blocks are protected, then these are ignored and all the other selected blocks are erased. If all of the selected blocks are protected, the BLOCK ERASE operation appears to start but will terminate within about 100 $\mu$ s, leaving the data unchanged. No error condition is given when protected blocks are ignored.

During the BLOCK ERASE operation, the memory will ignore all commands except the ERASE SUSPEND command. (Typical block erase times are given in the Program/Erase Characteristics.) All bus READ operations during the BLOCK ERASE operation will output the status register on the data I/Os.

After the BLOCK ERASE operation has completed, the memory will return to the read mode, unless an error has occurred. When an error occurs, the memory will continue to output the status register. A READ/RESET command must be issued to reset the error condition and return to read mode.

The BLOCK ERASE command sets all of the bits in the unprotected selected blocks to 1. All previous data in the selected blocks is lost.

## **ERASE SUSPEND Command**

The ERASE SUSPEND command may be used to temporarily suspend a BLOCK ERASE operation and return the memory to read mode. The command requires one bus WRITE operation.

The program/erase controller will suspend within the erase suspend latency time of the ERASE SUSPEND command being issued. After the program/erase controller has stopped, the memory will be set to read mode and the erase will be suspended. If the ERASE SUSPEND command is issued during the period when the memory is waiting for an additional block (before the program/erase controller starts), then the erase is suspended immediately and will start immediately when the ERASE RESUME command is issued. It is not possible to select any further blocks to erase after the ERASE RESUME.

During ERASE SUSPEND, it is possible to read and program cells in blocks that are not being erased; both READ and PROGRAM operations behave as normal on these blocks. If any attempt is made to program in a protected block or in the suspended block, then the PROGRAM command is ignored and the data remains unchanged. The status register is not read and no error condition is given. Reading from blocks that are being erased will output the status register.

It is also possible to issue the AUTO SELECT, READ CFI QUERY, and UNLOCK BYPASS commands during an ERASE SUSPEND. The READ/RESET command must be issued to return the device to read array mode before the RESUME command will be accepted.

### **ERASE RESUME Command**

The ERASE RESUME command must be used to restart the program/erase controller after an erase suspend. The device must be in read array mode before the RESUME command will be accepted. An erase can be suspended and resumed more than once.

### **ENTER EXTENDED BLOCK Command**

The device has an extra 256-byte block (extended block) that can only be accessed using the ENTER EXTENDED BLOCK command. Three bus WRITE cycles are required to issue the ENTER EXTENDED BLOCK command. After the command has been issued, the device enters extended block mode where all bus READ or WRITE operations to the boot block addresses access the extended block. The extended block (with the same address as the boot blocks) cannot be erased, and can be treated as OTP memory. In extended block mode, the boot blocks are not accessible.

The extended block can be protected; however, once protected, the protection cannot be undone.

### **EXIT EXTENDED BLOCK Command**

The EXIT EXTENDED BLOCK command is used to exit from the extended block mode and return the device to read mode. Four bus WRITE operations are required to issue the command.

### **BLOCK PROTECT and CHIP UNPROTECT Commands**

Groups of blocks can be protected against accidental program or erase. (See Memory Organization for the protection groups.) The whole chip can be unprotected to allow the data inside the blocks to be changed.

### **BLOCK PROTECT Command**

Block protection can be used to prevent any operation from modifying the data stored in the Flash. Each block can be protected individually. Once protected, PROGRAM and ERASE operations on the block fail to change the data.

There are three techniques that can be used to control block protection. These are programmer technique, in-system technique, and temporary unprotect. Temporary unprotect is controlled by RST#.

Unlike the command interface of the program/erase controller, the techniques for protecting and unprotecting blocks change between different Flash memory suppliers. Care should be taken when changing drivers for one part to work on another.

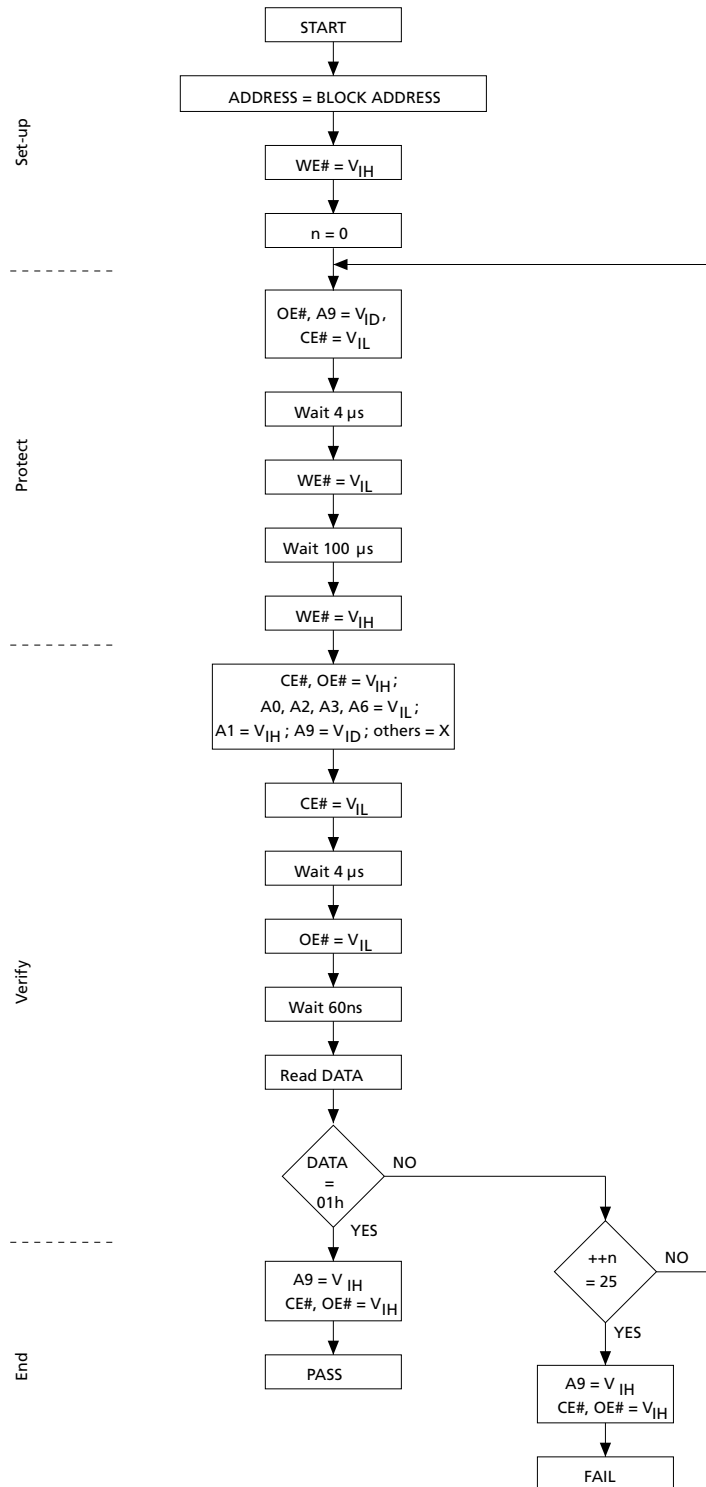
### Programmer Technique

The programmer technique uses high voltage levels ( $V^{ID}$ ) on some of the bus pins. These cannot be achieved using a standard microprocessor bus; therefore, the technique is recommended only for use in programming equipment.

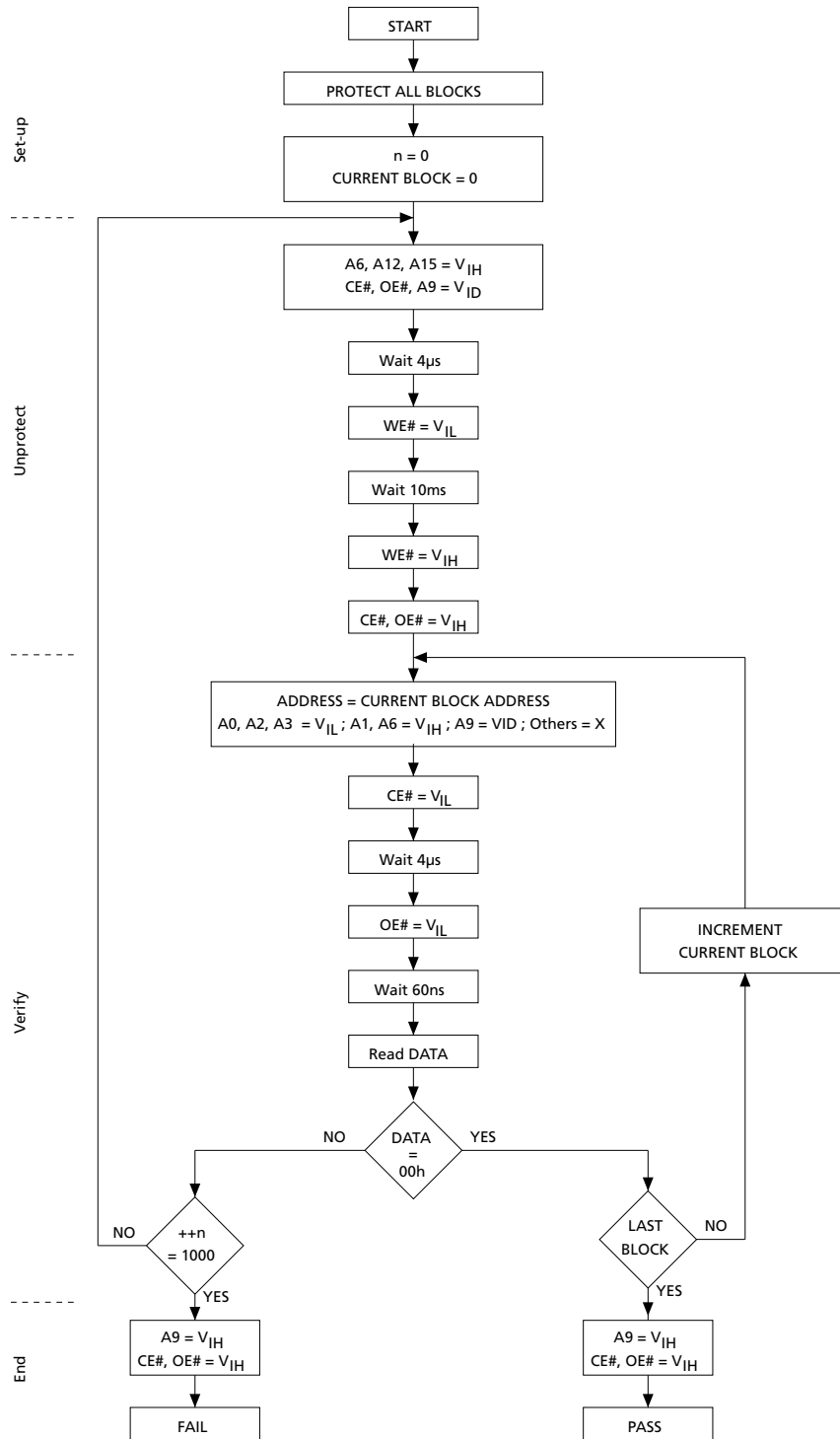
To protect a block, follow the steps in the following figure. To unprotect the whole chip, it is necessary to protect all of the blocks first, then all blocks can be unprotected at the same time. (See the Programmer Equipment Chip Protect Flowchart.)

The timing on these flowcharts is critical. Care should be taken to ensure that, where a pause is specified, it is followed as closely as possible. Do not abort the procedure before reaching the end. Chip unprotect can take several seconds and a user message should be provided to show that the operation is progressing.

**Figure 6: Programmer Equipment Block Protect Flowchart**



**Figure 7: Programmer Equipment Chip Unprotect Flowchart**



**Table 13: Programmer Technique Bus Operations**

Notes 1 and 2 apply to entire table

Operation	CE#	OE#	WE#	Address Inputs	Data I/O
				A[MAX:0]	DQ15/A-1, DQ[14:0]
BLOCK PROTECT	L	V <sub>ID</sub>	L pulse	A9 = V <sub>ID</sub> A[21:12] block addresses others = X	X
CHIP UNPROTECT	V <sub>ID</sub>	V <sub>ID</sub>	L pulse	A9 = V <sub>ID</sub> A12 = V <sub>IH</sub> A15 = V <sub>IH</sub> others = X	X
BLOCK PROTECTION VERIFY	L	L	V <sub>IH</sub>	A0, A2, A3 = V <sub>IL</sub> A1 = V <sub>IH</sub> A6 = V <sub>IL</sub> A9 = V <sub>ID</sub> A[21:12] block addresses others = X	Pass = XX01h Retry = XX00h
BLOCK UNPROTECT VERIFY	L	L	V <sub>IH</sub>	A0, A2, A3 = V <sub>IL</sub> A1 = V <sub>IH</sub> A6 = V <sub>IH</sub> A9 = V <sub>ID</sub> A[21:12] block addresses others = X	Retry = XX01h Pass = XX00h

- Notes:
1. Typical glitches of less than 5ns on CE# and WE# are ignored by the device and do not affect bus operations.
  2. H = Logic level HIGH (V<sub>IH</sub>); L = Logic level LOW (V<sub>IL</sub>); X = HIGH or LOW.

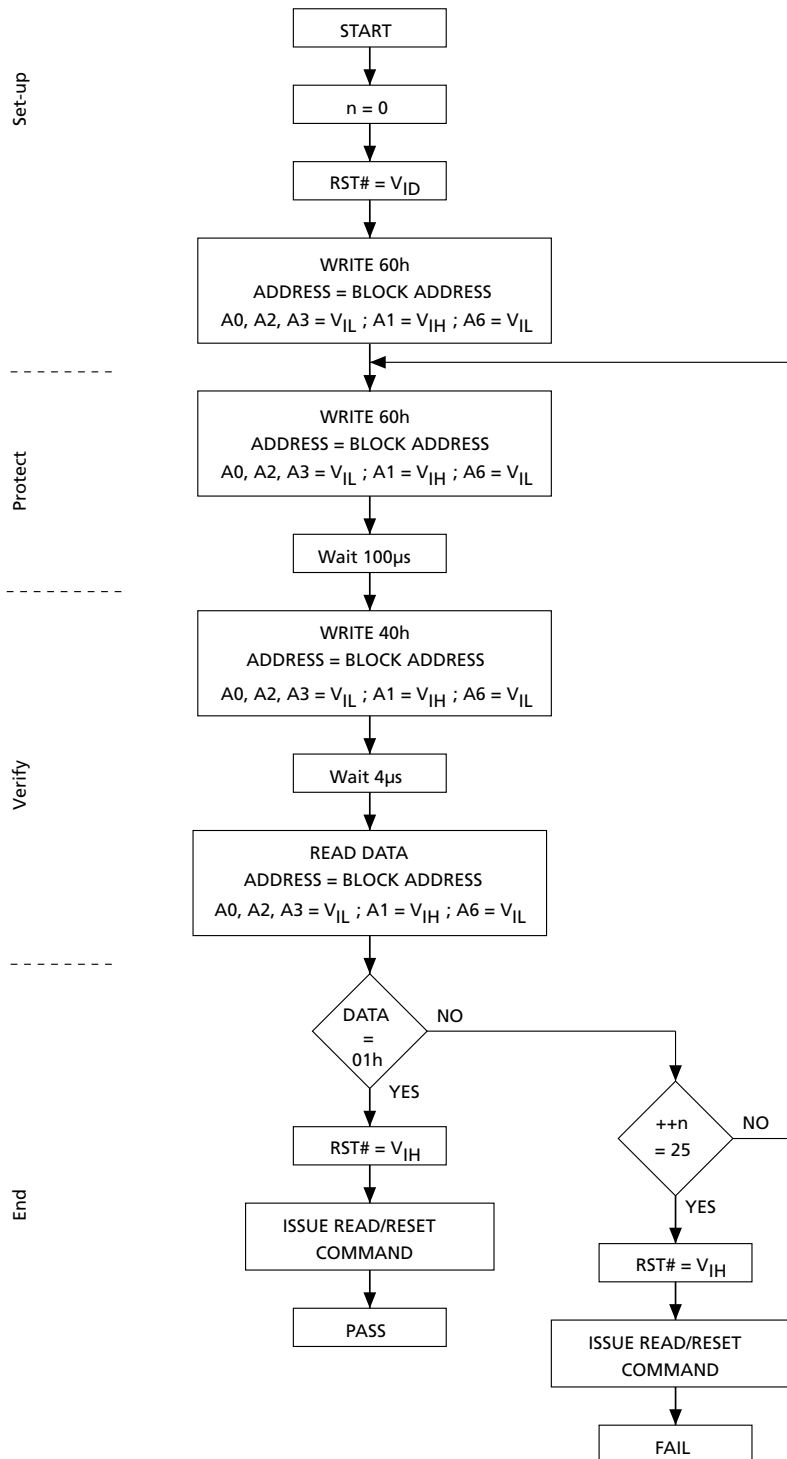
## In-System Technique

The in-system technique requires a high-voltage level on RST#. This can be achieved without violating the maximum ratings of the components on the microprocessor bus; therefore, this technique is suitable for use after the Flash has been fitted to the system.

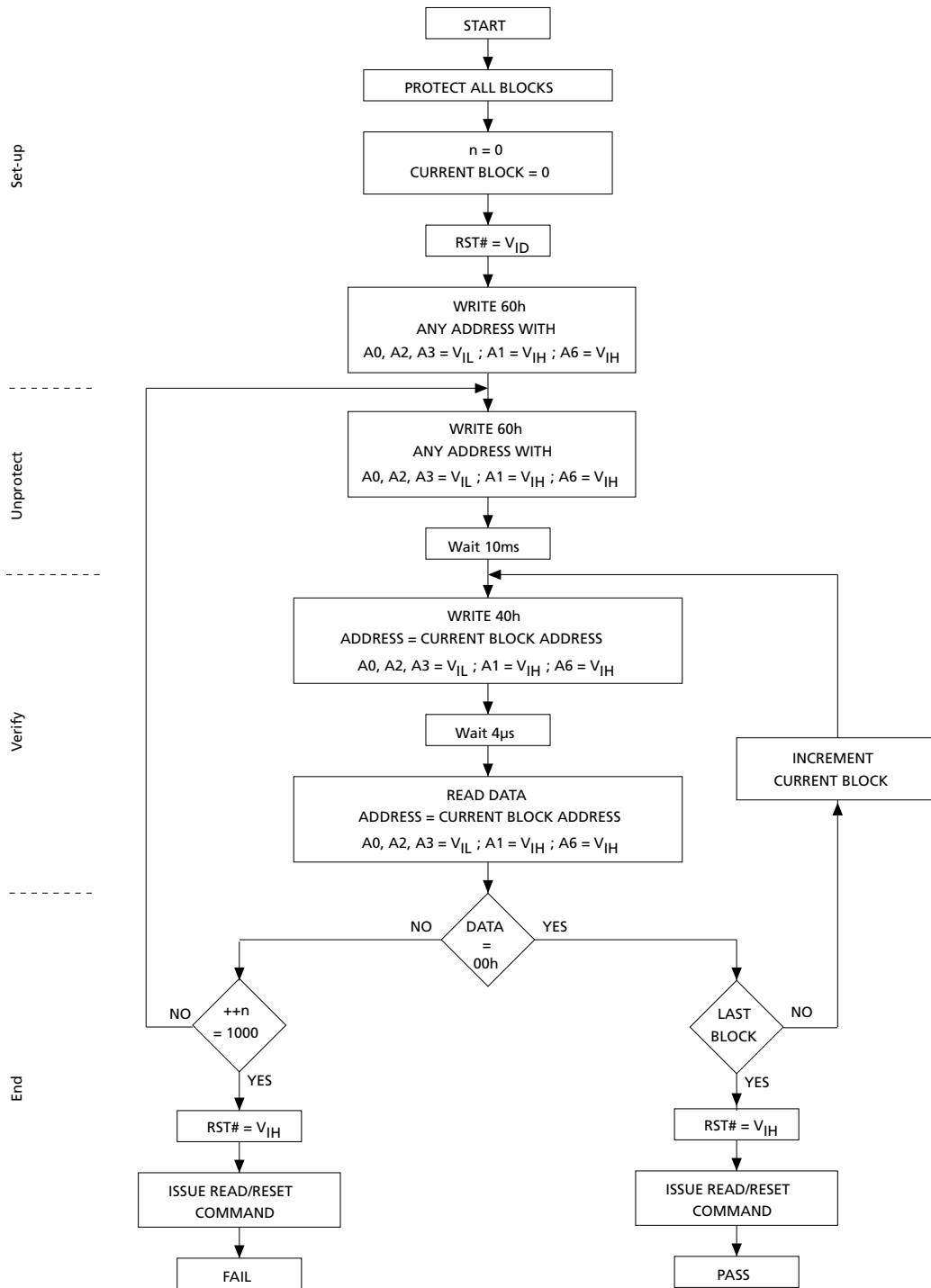
To protect a block, follow the steps in the following figure. To unprotect the whole chip, it is necessary to protect all of the blocks first, then all the blocks can be unprotected at the same time. (See the In-System Equipment Chip Unprotect Flowchart.)

The timing on these flowcharts is critical. Care should be taken to ensure that, where a pause is specified, it is followed as closely as possible. Do not allow the microprocessor to service interrupts that will upset the timing and do not abort the procedure before reaching the end. Chip unprotect can take several seconds and a user message should be provided to show that the operation is progressing.

Figure 8: In-System Equipment Block Protect Flowchart



**Figure 9: In-System Equipment Chip Protect Flowchart**



**Table 14: Commands – 16-Bit Mode (BYTE# = V<sub>IH</sub>)**

Command	Length	Bus WRITE Operations											
		1st		2nd		3rd		4th		5th		6th	
		Addr	Data	Addr	Data	Addr	Data	Addr	Data	Addr	Data	Addr	Data
READ/RESET	1	X	F0										
	3	555	AA	2AA	55	X	F0						
AUTO SELECT	3	555	AA	2AA	55	555	90						
READ CFI QUERY	1	555	98										
PROGRAM	4	55	AA	2AA	55	555	A0	PA	PD				
Double Word Program	3	555	50	PA0	PD0	PA1	PD1						
Quadruple Word Program	5	555	56	PA0	PD0	PA1	PD1	PA2	PD2	PA3	PD3		
UNLOCK BY-PASS	3	555	AA	2AA	55	555	20						
UNLOCK BY-PASS PROGRAM	2	X	A0	PA	PD								
UNLOCK BY-PASS RESET	2	X	90	X	00								
CHIP ERASE	6	555	AA	2AA	55	555	80	555	AA	2AA	55	555	10
BLOCK ERASE	6	555	AA	2AA	55	555	80	555	AA	2AA	55	BA	30
PROGRAM/ERASE SUSPEND	1	X	B0										
PROGRAM/ERASE RESUME	1	X	30										
ENTER EXTENDED BLOCK	3	555	AA	2AA	55	555	88						
EXIT EXTENDED BLOCK	4	555	AA	2AA	55	555	90	X	00				

Note: 1. X = " Don't Care;" PA = Program address; PD = Program data; BA = Any address in the block. All values in the table are in hexadecimal. The command interface only uses A-1; A0-A10 and DQ0-DQ7 to verify the commands; A11-A20, DQ8-DQ14 and DQ15 are "Don't Care." DQ15A-1 is A-1 when BYTE# is V<sub>IL</sub> or DQ15 when BYTE# is V<sub>IH</sub>.

**Table 15: Commands – 8-Bit Mode (BYTE# = V<sub>IL</sub>)**

Command	Length	Bus WRITE Operations												
		1st		2nd		3rd		4th		5th		6th		
		Addr	Data	Addr	Data	Addr	Data	Addr	Data	Addr	Data	Addr	Data	
READ/RESET	1	X	F0											
	3	AAA	AA	555	55	X	F0							
AUTO SELECT	3	AAA	AA	555	55	AAA	90							
READ CFI QUERY	1	AA	98											
PROGRAM	4	AAA	AA	555	55	AAA	A0	PA	PD					
DOUBLE BYTE PROGRAM	3	AAA	50	PA0	PD0	PA1	PD1							
QUADRUPLE BYTE PROGRAM	5	AAA	56	PA0	PD0	PA1	PD1	PA2	PD2	PA3	PD3			
OCTUPLE BYTE PROGRAM	9	AAA	8B	PA0	PD0	PA1	PD1	PA2	PD2	PA3	PD3	PA4	PD4 <sup>2</sup>	
UNLOCK BY-PASS	3	AAA	AA	555	55	AAA	20							
UNLOCK BY-PASS PROGRAM	2	X	A0	PA	PD									
UNLOCK BY-PASS RESET	2	X	90	X	00									
CHIP ERASE	6	AAA	AA	555	55	AAA	80	AAA	AA	555	55	AAA	10	
BLOCK ERASE	6+	AAA	AA	555	55	AAA	80	AAA	AA	555	55	BA	30	
PROGRAM/ERASE SUSPEND	1	X	B0											
PROGRAM/ERASE RESUME	1	X	30											
ENTER EXTENDED BLOCK	3	AAA	AA	555	55	AAA	88							
EXIT EXTENDED BLOCK	4	AAA	AA	555	55	AAA	90	X	00					

- Notes:
1. X = " Don't Care;" PA = Program address; PD = Program data; BA = Any address in the block. All values in the table are in hexadecimal. The command interface only uses A-1, A0-A10, and DQ0-DQ7 to verify the commands; A11-A20, DQ8-DQ14, and DQ15 are "Don't Care." DQ15A-1 is A-1 when BYTE# is V<sub>IL</sub> or DQ15 when BYTE# is V<sub>IH</sub>.
  2. The following is content for address and Data cycles 7 through 9: PA5-PD5, PA6-PD6, PA7-PD7

## Common Flash Interface

The common Flash interface (CFI) is a JEDEC-approved, standardized data structure that can be read from the Flash memory device. It allows a system's software to query the device to determine various electrical and timing parameters, density information, and functions supported by the memory. The system can interface easily with the device, enabling the software to upgrade itself when necessary.

When the READ CFI command is issued, the device enters CFI query mode and the data structure is read from memory. The following tables show the addresses (A-1, A[7:0]) used to retrieve the data. The query data is always presented on the lowest order data outputs (DQ[7:0]), and the other data outputs (DQ[15:8]) are set to 0.

**Table 16: Query Structure Overview**

Note 1 applies to the entire table

Address		Subsection Name	Description
x16	x8		
10h	20h	CFI query identification string	Command set ID and algorithm data offset
1Bh	36h	System interface information	Device timing and voltage information
27h	4Eh	Device geometry definition	Flash device layout
40h	80h	Primary algorithm-specific extended query table	Additional information specific to the primary algorithm (optional)
61h	C2h	Security code area	64-bit unique device number

Note: 1. Query data are always presented on the lowest order data outputs (DQ[7:0]). DQ[15:8] are set to 0.

**Table 17: CFI Query Identification String**

Note 1 applies to the entire table

Address		Data	Description	Value
x16	x8			
10h	20h	0051h	Query unique ASCII string "QRY"	"Q"
11h	22h	0052h		"R"
12h	24h	0059h		"Y"
13h	26h	0002h	Primary algorithm command set and control interface ID code 16-bit ID code defining a specific algorithm	AMD compatible
14h	28h	0000h		
15h	2Ah	0040h	Address for primary algorithm extended query table (see the Primary Algorithm-Specific Extended Query Table)	P = 40h
16h	2Ch	0000h		
17h	2Eh	0000h	Alternate vendor command set and control interface ID code second vendor-specified algorithm supported	-
18h	30h	0000h		
19h	32h	0000h	Address for alternate algorithm extended query table	-
1Ah	34h	0000h		

Note: 1. Query data are always presented on the lowest order data outputs (DQ[7:0]). DQ[15:8] are set to 0.

**Table 18: CFI Query System Interface Information**

Note 1 applies to the entire table

Address		Data	Description	Value
x16	x8			
1Bh	36h	0027h	V <sub>CC</sub> logic supply minimum program/erase voltage Bits[7:4] BCD value in volts Bits[3:0] BCD value in 100mV	2.7V
1Ch	38h	0036h	V <sub>CC</sub> logic supply maximum program/erase voltage Bits[7:4] BCD value in volts Bits[3:0] BCD value in 100mV	3.6V
1Dh	3Ah	00B5h	V <sub>PPH</sub> (programming) supply minimum program/erase voltage Bits[7:4] hex value in volts Bits[3:0] BCD value in 100mV	11.5V
1Eh	3Ch	00C5h	V <sub>PPH</sub> (programming) supply maximum program/erase voltage Bits[7:4] hex value in volts Bits[3:0] BCD value in 100mV	12.5V
1Fh	3Eh	0004h	Typical timeout for single byte/word program = 2 <sup>n</sup> μs	16μs
20h	40h	0000h	Typical timeout for maximum size buffer program = 2 <sup>n</sup> μs	NA
21h	42h	000Ah	Typical timeout per individual block erase = 2 <sup>n</sup> ms	1s
22h	44h	0000h	Typical timeout for full chip erase = 2 <sup>n</sup> ms	NA
23h	46h	0004h	Maximum timeout for byte/word program = 2 <sup>n</sup> times typical	256μs
24h	48h	0004h	Maximum timeout for buffer program = 2 <sup>n</sup> times typical	200μs
25h	4Ah	0003h	Maximum timeout per individual block erase = 2 <sup>n</sup> times typical	8s
26h	4Ch	0000h	Maximum timeout for chip erase = 2 <sup>n</sup> times typical	NA

Note: 1. The values in this table are valid for both packages.

**Table 19: Device Geometry Definition**

Address		Data	Description	Value
x16	x8			
27h	4Eh	0017h	Device size = 2 <sup>n</sup> in number of bytes	8MB
28h	50h	0002h	Flash device interface code description	x8, x16 asynchronous
29h	52h	0000h		
2Ah	54h	0004h	Maximum number of bytes in multi-byte program or page = 2 <sup>n</sup>	16B
2Bh	56h	0000h		
2Ch	58h	0002h	Number of erase block regions. It specifies the number of regions containing contiguous erase blocks of the same size.	2
Erase block region 1 information				
2Dh	5Ah	0007h	Number of identical-size erase blocks = 00FFh + 1	8
2Eh	5Ch	0000h		
2Fh	5Eh	0020h	Block size = 0200h × 256 bytes	8KB
30h	60h	000h		
Erase block region 2 information				

**Table 19: Device Geometry Definition (Continued)**

Address		Data	Description	Value
x16	x8			
31h	62h	007Eh	Number of erase blocks of identical size = 007Eh + 1	127
32h	64h	0000h		
33h	66h	0000h	Block size = 0100h x 256 byte	64KB
34h	68h	0000h		
Erase block region 3 information				
35h	6Ah	0000h	Number of erase blocks of identical size = 007Fh+1	0
36h	6Ch	0000h		
37h	6Eh	0000h	Block size = 0000h x 256 byte	0
38h	70h	0000h		
Erase block region 4 information				
39h	72h	0000h	Number of erase blocks of identical size = 007Fh + 1	0
3Ah	74h	0000h		
3Bh	76h	0000h	Block size in region 4 = 0000h x 256 byte	0
3Ch	78h	0000h		

Note: 1. Bottom boot device, erase block region address locations: region 1 is address 000000h to 007FFFh; region 2 is address 008000h to 3FFFFFFh. Top boot device, erase block region address locations: region 1 is address 000000h to 3F7FFFh; region 2 is address 3F8000h to 3FFFFFFh.

**Table 20: Primary Algorithm-Specific Extended Query Table**

Note 1 applies to the entire table

Address		Data	Description	Value
x16	x8			
40h	80h	0050h	Primary algorithm extended query table unique ASCII string "PRI"	"P"
41h	82h	0052h		"R"
42h	84h	0049h		"I"
43h	86h	0031h	Major version number, ASCII	"1"
44h	88h	0033h	Minor version number, ASCII	"3"
45h	8Ah	0000h	Address sensitive unlock (bits[1:0]): 00 = Required 01 = Not required Silicon revision number (bits[7:2])	Yes 65nm
46h	8Ch	0002h	Erase suspend: 00 = Not supported 01 = Read only 02 = Read and write	2
47h	8Eh	0004h	Block protection: 00 = Not supported x = Number of blocks per group	4

**Table 20: Primary Algorithm-Specific Extended Query Table (Continued)**

Note 1 applies to the entire table

Address		Data	Description	Value
x16	x8			
48h	90h	0001h	Temporary block unprotect: 00 = Not supported 01 = Supported	Yes
49h	92h	0004h	Block protect/unprotect: 04=M29W640F	04
4Ah	94h	0000h	Simultaneous operations: 00h = Not supported	No
4Bh	96h	0000h	Burst mode: 00 = Not supported 01 = Supported	No
4Ch	98h	0001h	Page mode: 00 = Not supported 01 = 4-word page 02 = 8-word page	Yes
4Dh	9Ah	00B5h	V <sub>PPH</sub> supply minimum program/erase voltage: Bits[7:4] hex value in volts Bits[3:0] BCD value in 100mV	11.5V
4Eh	9Ch	00C5h	V <sub>PPH</sub> supply maximum program/erase voltage: Bits[7:4] hex value in volts Bits[3:0] BCD value in 100mV	12.5V
4Fh	9Eh	00xxh	Top/bottom boot block flag: 02h = Bottom boot device 03h = Top boot device	Uniform + V <sub>PP</sub> /WP# protect- ing highest or lowest block
50h	A0h	0001h	Program suspend: 00 = Not supported 01 = Supported	01

Note: 1. The values in this table are valid for both packages.

**Table 21: Security Code Area**

Address		Data	Description
x16	x8		
61h	C3h, C2h	XXXX	64-bit unique device number
62h	C5h, C4h	XXXX	
63h	C7h, C6h	XXXX	
64h	C9h, C8h	XXXX	

### Absolute Ratings and Operating Conditions

Stresses greater than those listed may cause permanent damage to the device. This is a stress rating only, and functional operation of the device at these or any other conditions outside those indicated in the operational sections of this specification is not implied. Exposure to absolute maximum rating conditions for extended periods may adversely affect reliability.

**Table 22: Absolute Maximum/Minimum Ratings**

Parameter	Symbol	Min	Max	Unit	Notes
Temperature under bias	$T_{BIAS}$	-50	125	°C	
Storage temperature	$T_{STG}$	-65	150	°C	
Input/output voltage	$V_{IO}$	-0.6	$V_{CC} + 0.6$	V	1, 2
Supply voltage	$V_{CC}$	-0.6	4	V	
Program voltage	$V_{PP}$	-0.6	13.5	V	
Identification voltage	$V_{ID}$	-0.6	13.5	V	

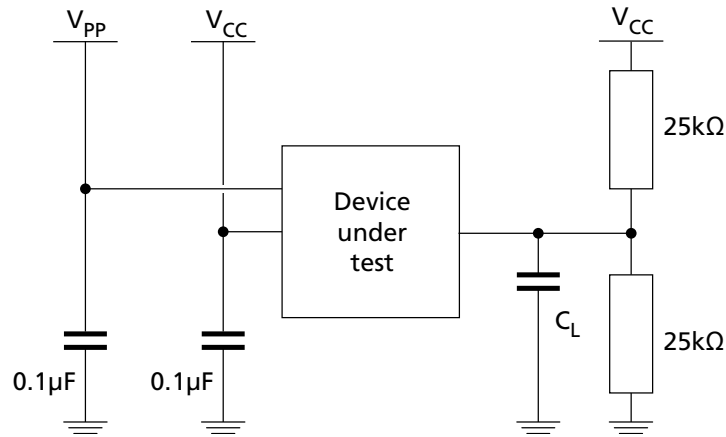
- Notes:
1. During signal transitions, minimum voltage may undershoot to  $-2V$  for periods less than 20ns.
  2. During signal transitions, maximum voltage may overshoot to  $V_{CC} + 2V$  for periods less than 20ns.

**Table 23: Operating Conditions**

Parameter	Symbol	M29W640FT/B		Unit
		Min	Max	
Supply voltage	$V_{CC}$	2.7	3.6	V
Ambient operating temperature	$T_A$	-40	85	°C
Load capacitance	$C_L$	30		pF
Input rise and fall times	–	–	10	ns
Input pulse voltages	–	0 to $V_{CC}$		V
I/O timing reference voltages	–	$V_{CC}/2$		V

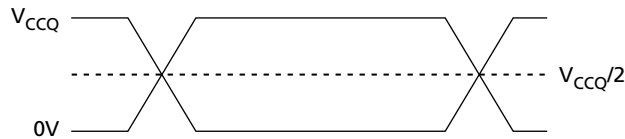
- Note: 1. 85°C = industrial part; 125°C = automotive grade part.

**Figure 10: AC Measurement Load Circuit**



Note: 1.  $C_L$  includes jig capacitance.

**Figure 11: AC Measurement I/O Waveform**



**Table 24: Input/Output Capacitance**

Parameter	Symbol	Test Condition	Min	Max	Unit
Input capacitance	$C_{IN}$	$V_{IN} = 0\text{V}$	–	6	pF
Output capacitance	$C_{OUT}$	$V_{OUT} = 0\text{V}$	–	12	pF

Note: 1. Sampled only, not 100% tested.

## DC Characteristics

**Table 25: DC Current Characteristics**

Parameter	Symbol	Conditions	Typ	Max	Unit	Notes
Input leakage current	$I_{LI}$	$0V \leq V_{IN} \leq V_{CC}$	–	$\pm 1$	$\mu A$	
Output leakage current	$I_{LO}$	$0V \leq V_{OUT} \leq V_{CC}$	–	$\pm 1$	$\mu A$	
Read current	$I_{CC1}$	CE# = $V_{IL}$ , OE# = $V_{IH}$ , $f = 6 \text{ MHz}$		10	mA	1
Standby current	$I_{CC2}$	CE# = $V_{CC} \pm 0.2V$ RP# = $V_{CC} \pm 0.2V$		100	$\mu A$	2
Program/erase current	$I_{CC3}$	Program/erase controller active: $V_{pp}/WP\# = V_{IL}$ or $V_{IH}$ ; $V_{pp}/WP\# = V_{pp}$	–	20	mA	1, 3
Current for $V_{pp}/WP\#$ program acceleration	$I_{pp}$	$V_{CC} = 2.7V \pm 10\%$	–	15	mA	

- Notes:
1. In dual operations, the supply current will be the sum of  $I_{CC1}$  (READ operation) and  $I_{CC3}$  (PROGRAM/ERASE operation).
  2. When the bus is inactive for 300ns or more, the memory enters automatic standby.
  3. Sampled only; not 100% tested.

**Table 26: DC Voltage Characteristics**

Parameter	Symbol	Conditions	Min	Max	Unit
Input LOW voltage	$V_{IL}$	–	–0.5	0.8	V
Input HIGH voltage	$V_{IH}$	–	$0.7 V_{CCQ}$	$V_{CC} + 0.3$	V
Voltage for $V_{pp}/WP\#$ program acceleration	$V_{pp}$	$V_{CC} = 2.7V \pm 10\%$	11.5	12.5	V
Output LOW voltage	$V_{OL}$	$I_{OL} = 1.8mA$	–	0.45	V
Output HIGH voltage	$V_{OH}$	$I_{OH} = -100\mu A$	$V_{CC} - 0.4$	–	V
Identification voltage	$V_{ID}$	–	11.5	12.5	V
Program/erase lockout supply voltage	$V_{LKO}$	–	1.8	2.3	V

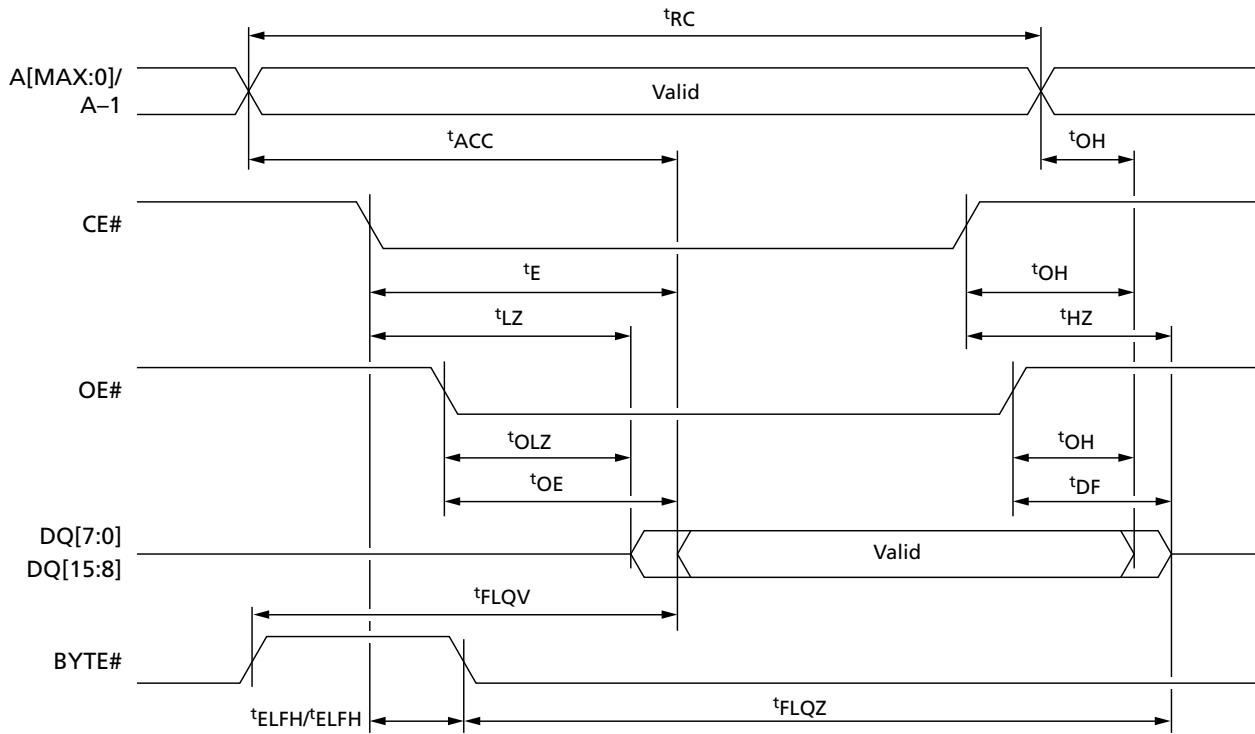
## Read AC Characteristics

**Table 27: Read AC Characteristics**

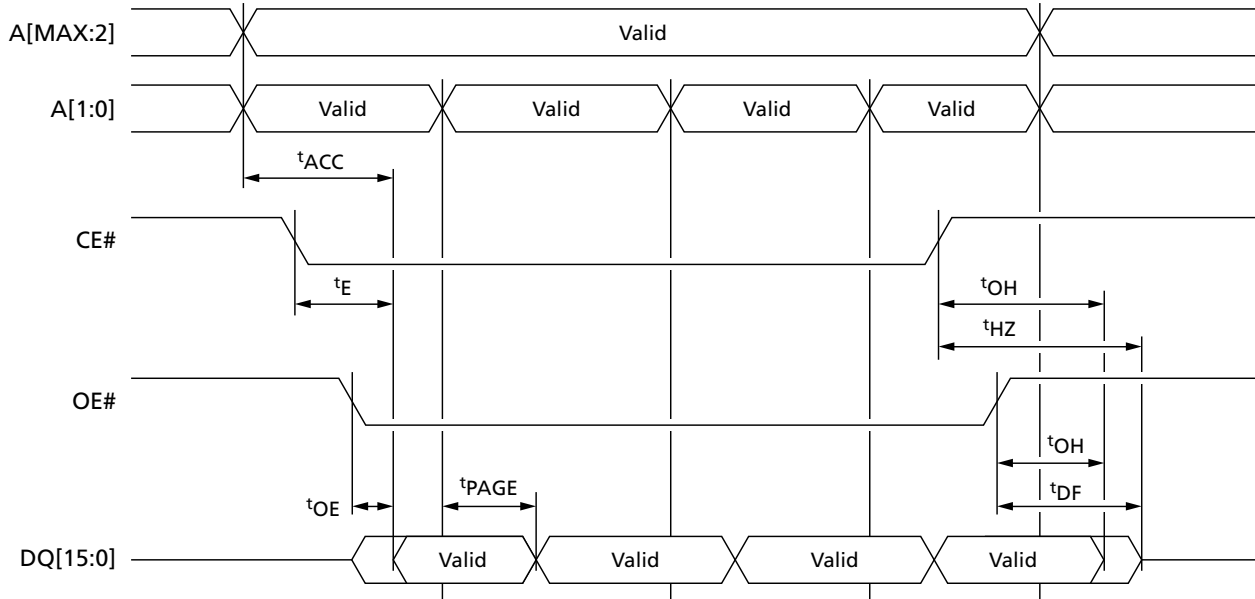
Parameter	Symbol		Condition	60		70		Unit	Notes
	Legacy	JEDEC		Min	Max	Min	Max		
Address valid to next address valid	$t_{RC}$	$t_{AVAV}$	CE# = $V_{IL}$ , OE# = $V_{IL}$	60	–	70	–	ns	
Address valid to output valid	$t_{ACC}$	$t_{AVQV}$	CE# = $V_{IL}$ , OE# = $V_{IL}$	–	60	–	70	ns	
Address valid to output valid (page)	$t_{PAGE}$	$t_{AVQV1}$	CE# = $V_{IL}$ , OE# = $V_{IL}$	–	25	–	25	ns	
CE# LOW to output transition	$t_{LZ}$	$t_{ELQX}$	OE# = $V_{IL}$	0	–	0	–	ns	1
CE# LOW to output valid	$t_E$	$t_{ELQV}$	OE# = $V_{IL}$	–	60	–	70	ns	
OE# LOW to output transition	$t_{OLZ}$	$t_{GLQX}$	CE# = $V_{IL}$	0	–	0	–	ns	1
OE# LOW to output valid	$t_{OE}$	$t_{GLQV}$	CE# = $V_{IL}$	–	25	–	25	ns	
CE# HIGH to output High-Z	$t_{HZ}$	$t_{EHQZ}$	OE# = $V_{IL}$	–	25	–	25	ns	1
OE# HIGH to output High-Z	$t_{DF}$	$t_{GHQZ}$	CE# = $V_{IL}$	–	25	–	25	ns	1
CE#, OE#, or address transition to output transition	$t_{OH}$	$t_{EHQX}$ , $t_{GHQX}$ , $t_{AXQX}$	–	0	–	0	–	ns	
CE# to BYTE# LOW	$t_{ELFL}$	$t_{ELBL}$	–	–	5	–	5	ns	
CE# to BYTE# HIGH	$t_{ELFH}$	$t_{ELBH}$	–	–	5	–	5	ns	
BYTE# LOW to output High-Z	$t_{FLQZ}$	$t_{BLQZ}$	–	–	25	–	25	ns	
BYTE# HIGH to output valid	$t_{FHQV}$	$t_{BHQV}$	–	–	30	–	30	ns	

Note: 1. Sampled only; not 100% tested.

**Figure 12: Random AC Timing**



**Figure 13: Page Read AC Timing**





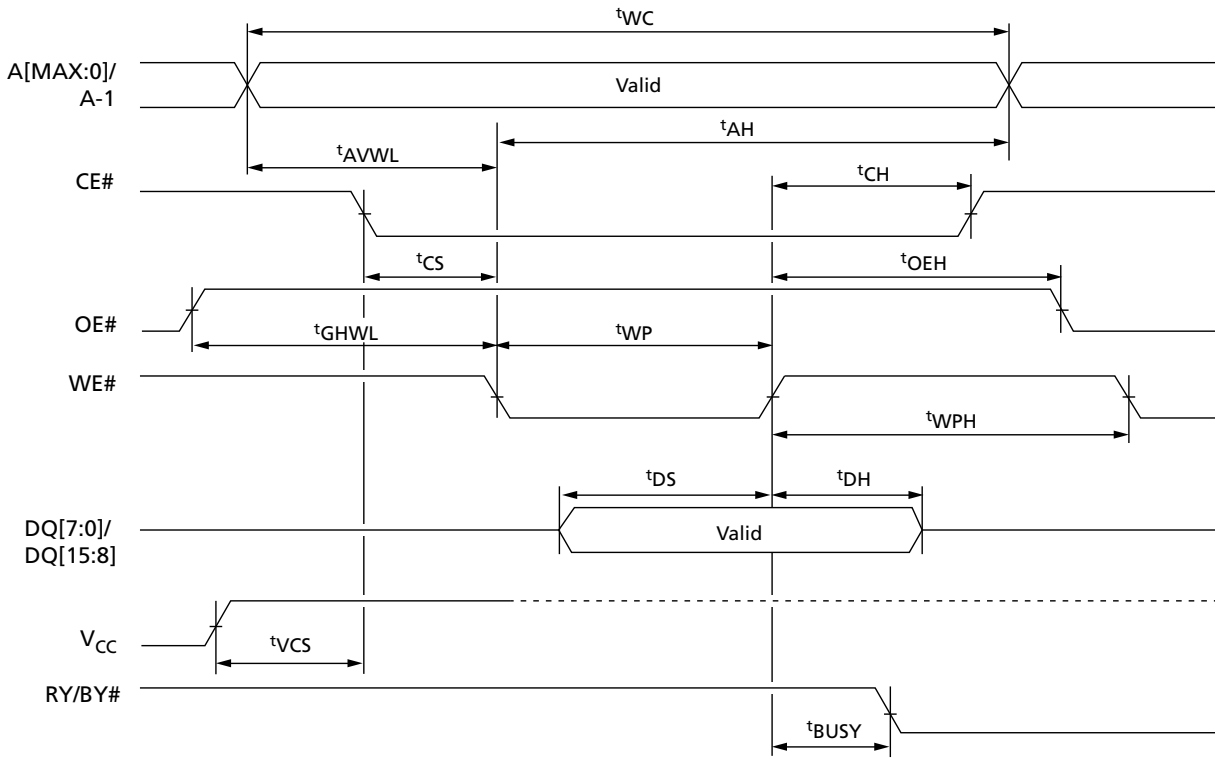
## Write AC Characteristics

Table 28: WE#-Controlled Write AC Characteristics

Parameter	Symbol		60		70		Unit	Notes
	Legacy	JEDEC	Min	Max	Min	Max		
Address valid to next address valid	t <sup>WC</sup>	t <sup>AVAV</sup>	60	–	70	–	ns	
CE# LOW to WE# LOW	t <sup>CS</sup>	t <sup>ELWL</sup>	0	–	0	–	ns	
WE# LOW to WE# HIGH	t <sup>WP</sup>	t <sup>WLWH</sup>	45	–	45	–	ns	
Input valid to WE# HIGH	t <sup>DS</sup>	t <sup>DVWH</sup>	45	–	45	–	ns	
WE# HIGH to input transition	t <sup>DH</sup>	t <sup>WHDX</sup>	0	–	0	–	ns	
WE# HIGH to CE# HIGH	t <sup>CH</sup>	t <sup>WHEH</sup>	0	–	0	–	ns	
WE# HIGH to WE# LOW	t <sup>WPH</sup>	t <sup>WHWL</sup>	30	–	30	–	ns	
Address valid to WE# LOW	t <sup>AS</sup>	t <sup>AVWL</sup>	0	–	0	–	ns	
WE# LOW to address transition	t <sup>AH</sup>	t <sup>WLAX</sup>	45	–	45	–	ns	
OE# HIGH to WE# LOW	–	t <sup>GHWL</sup>	0	–	0	–	ns	
WE# HIGH to OE# LOW	t <sup>OEH</sup>	t <sup>WHGL</sup>	0	–	0	–	ns	
Program/erase valid to RY/BY# LOW	t <sup>BUSY</sup>	t <sup>WHRL</sup>	–	30	–	30	ns	1
V <sub>CC</sub> HIGH to CE# LOW	t <sup>VCS</sup>	t <sup>VCHEL</sup>	50	–	50	–	μs	

Note: 1. Sampled only; not 100% tested.

**Figure 14: WE#-Controlled AC Timing**

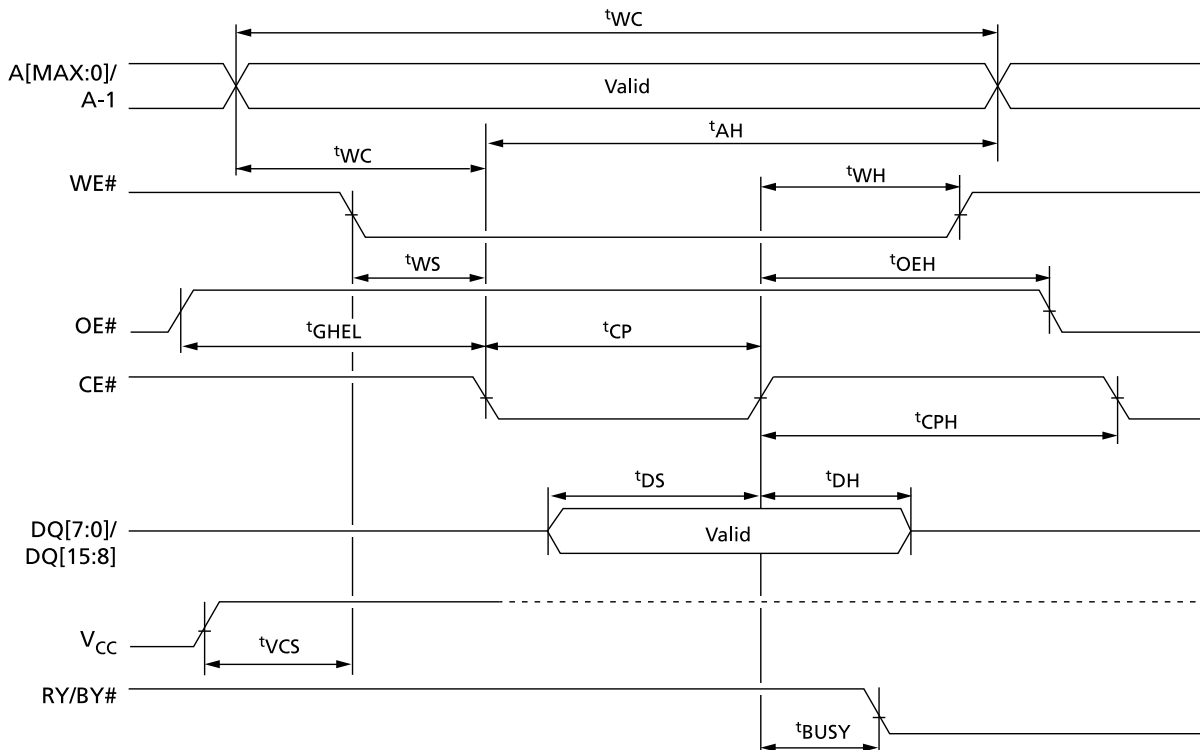


**Table 29: CE#-Controlled Write AC Characteristics**

Parameter	Symbol		60		70		Unit	Notes
	Legacy	JEDEC	Min	Max	Min	Max		
Address valid to next address valid	$t^{\text{WC}}$	$t^{\text{AVAV}}$	60	–	70	–	ns	
WE# LOW to CE# LOW	$t^{\text{WS}}$	$t^{\text{WLEL}}$	0	–	0	–	ns	
CE# LOW to CE# HIGH	$t^{\text{CP}}$	$t^{\text{ELEH}}$	45	–	45	–	ns	
Input valid to CE# HIGH	$t^{\text{DS}}$	$t^{\text{DVEH}}$	45	–	45	–	ns	
CE# HIGH to input transition	$t^{\text{DH}}$	$t^{\text{EHDX}}$	0	–	0	–	ns	
CE# HIGH to WE# HIGH	$t^{\text{WH}}$	$t^{\text{EHWH}}$	0	–	0	–	ns	
CE# HIGH to CE# LOW	$t^{\text{CPH}}$	$t^{\text{EHEL}}$	30	–	30	–	ns	
Address valid to CE# LOW	$t^{\text{AS}}$	$t^{\text{AVEL}}$	0	–	0	–	ns	
CE# LOW to address transition	$t^{\text{AH}}$	$t^{\text{ELAX}}$	45	–	45	–	ns	
OE# HIGH to CE# LOW	–	$t^{\text{GHEL}}$	0	–	0	–	ns	
CE# HIGH to OE# LOW	$t^{\text{OEH}}$	$t^{\text{EHGL}}$	0	–	0	–	ns	
Program/erase valid to RY/BY# LOW	$t^{\text{BUSY}}$	$t^{\text{EHRL}}$	–	30	–	30	ns	1
V <sub>CC</sub> HIGH to WE# LOW	$t^{\text{VCS}}$	$t^{\text{VCHWL}}$	50	–	50	–	ns	

Note: 1. Sampled only; not 100% tested.

**Figure 15: CE#-Controlled AC Timing**



## Program/Erase Characteristics

**Table 30: Program/Erase Times and Endurance Cycles**

Notes 1 and 2 apply to the entire table

Parameter	Min	Typ	Max	Unit	Notes
Chip erase	–	80	400	s	3
Block erase (64KB)	–	0.8	6	s	4
Erase suspend latency time	–	–	50	μs	4
Program (byte or word)	–	10	200	μs	3
Double byte	–	10	200	μs	
Double word /quadruple byte program		10	200	μs	3
Quadruple word/octuple byte program		10	200	μs	3
Chip program (byte by byte)	–	80	400	s	3
Chip program (word by word)	–	40	200	s	3
Chip program (double word/quadruple byte program)	–	20	100	s	3
Chip program (quadruple word/octuple byte program)	–	10	50	s	3
Program suspend latency time	–	–	4	μs	
PROGRAM/ERASE cycles (per block)	100,000	–	–	cycles	
Data retention	20	–	–	years	

- Notes:
1. Typical values measured at room temperature and nominal voltages.
  2. Sampled, but not 100% tested.
  3. Maximum value measured at worst case conditions for both temperature and  $V_{CC}$  after 100,000 PROGRAM/ERASE cycles.
  4. Maximum value measured at worst case conditions for both temperature and  $V_{CC}$ .

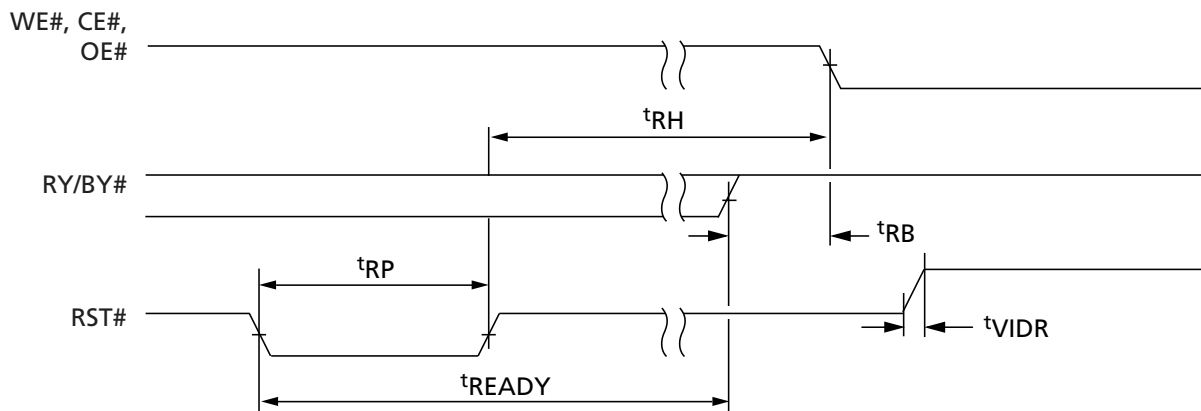
## Reset Characteristics

**Table 31: Reset/Block Temporary Unprotect AC Characteristics**

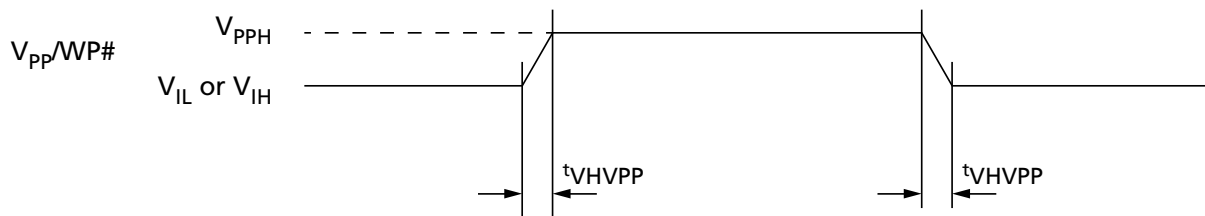
Condition/Parameter		Symbol		M29W640FT/B		Unit	Notes
		Legacy	JEDEC	60	70		
RST# HIGH to WE# LOW, CE# LOW, OE# LOW	Min	$t_{RH}$	$t_{PHWL}$ $t_{PHEL}$ $t_{PHGL}$	50	50	ns	1
RY/BY# HIGH to WE# LOW, CE# LOW, OE# LOW	Min	$t_{RB}$	$t_{RHWL}$ $t_{RHEL}$ $t_{RHGL}$	0	0	ns	1
RST# pulse width	Min	$t_{RP}$	$t_{PLPX}$	500	500	ns	
RST# LOW to read mode	Max	$t_{READY}$	$t_{PLYH}$	50	50	$\mu s$	1
RST# rise time to $V_{ID}$	Min	$t_{VIDR}$	$t_{PHPHH}$	500	500	ns	1
$V_{PP}$ rise and fall time		$t_{VHVPP}$		250	250	ns	1

Note: 1. Sampled only; not 100% tested.

**Figure 16: Reset/block Temporary Unprotect AC Waveforms**

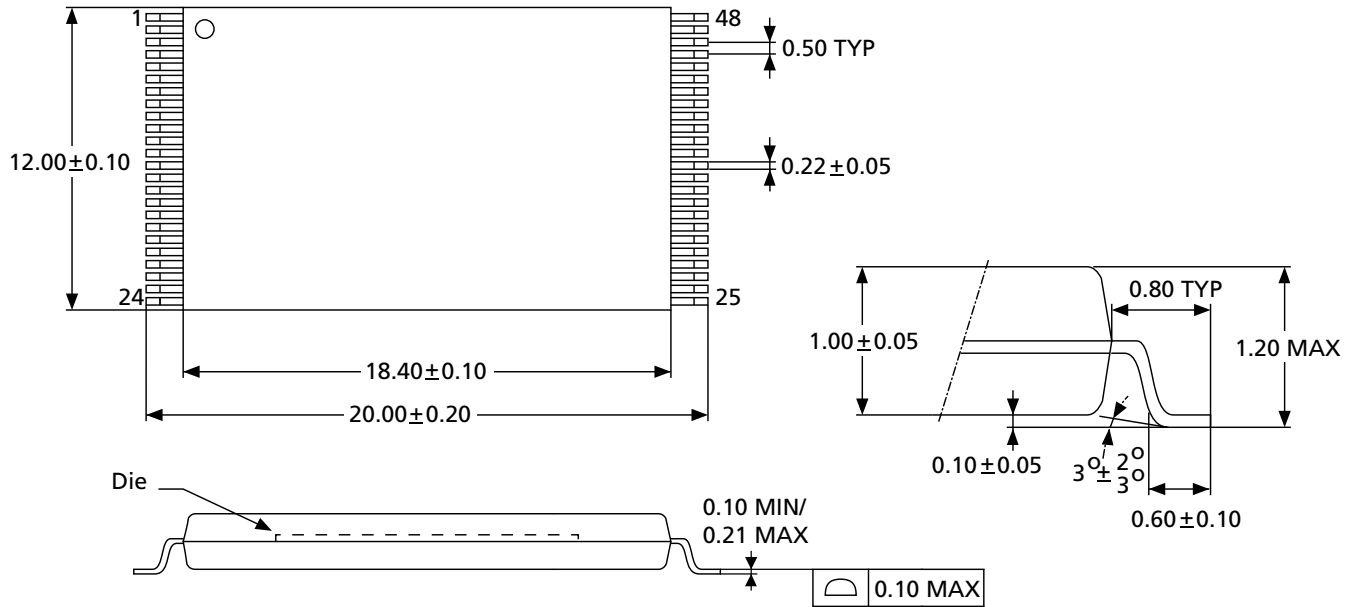


**Figure 17: Accelerated Program Timing Waveforms**



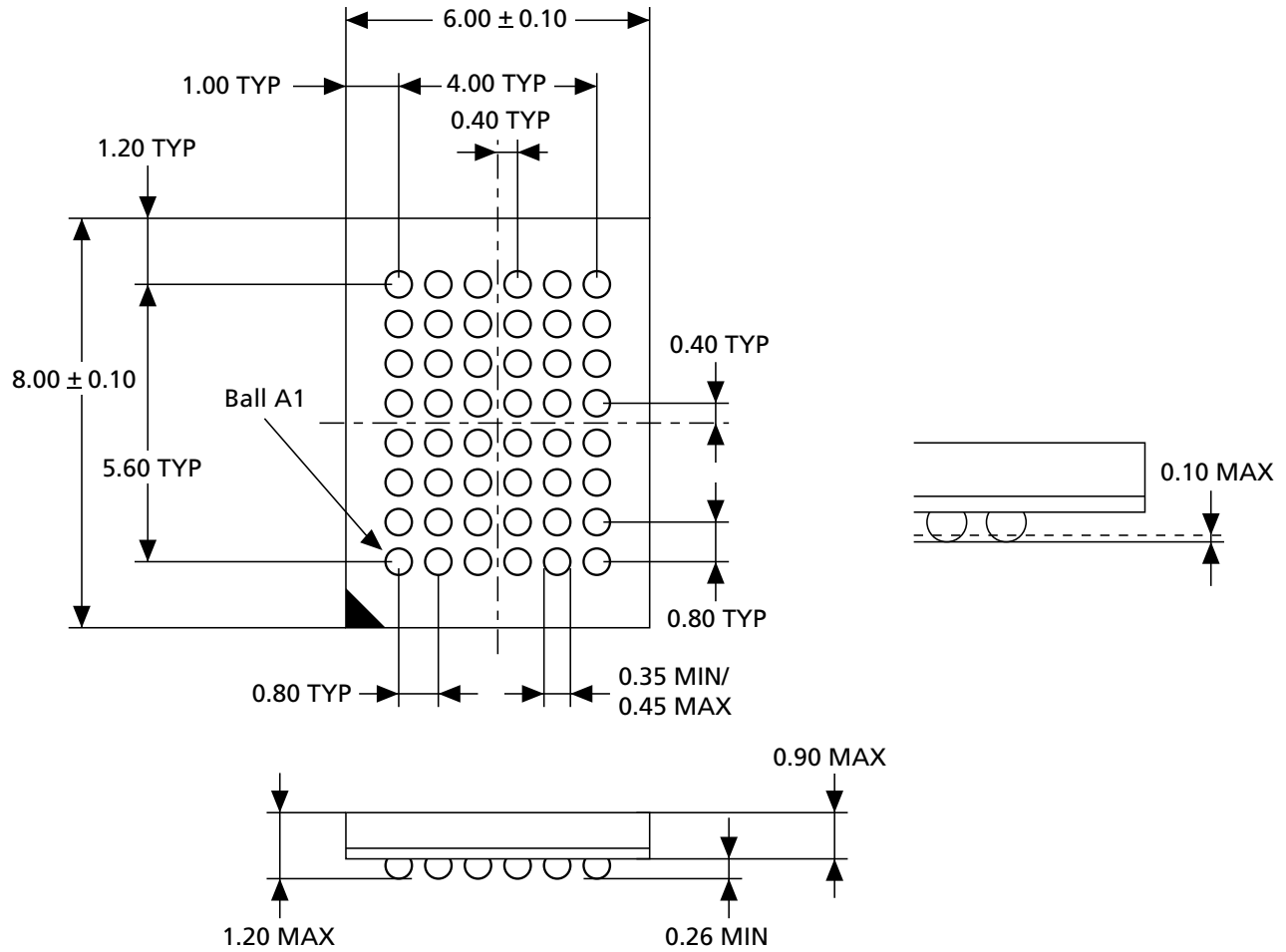
## Package Dimensions

Figure 18: 48-Pin TSOP – 12mm x 20mm



Note: 1. All dimensions are in millimeters.

**Figure 19: 48-Ball TFBGA – 6mm x 8mm**



Note: 1. All dimensions are in millimeters.

## Revision History

### Rev. C – 2/18

- Added Important Notes and Warnings section for further clarification aligning to industry standards

### Rev. B – 01/16

- Updated Commands tables for 16-Bit Mode and 8-Bit Mode in Command Interface

### Rev. A – 07/13

- Initial Micron brand release

8000 S. Federal Way, P.O. Box 6, Boise, ID 83707-0006, Tel: 208-368-4000  
[www.micron.com/products/support](http://www.micron.com/products/support) Sales inquiries: 800-932-4992  
Micron and the Micron logo are trademarks of Micron Technology, Inc.  
All other trademarks are the property of their respective owners.

This data sheet contains minimum and maximum limits specified over the power supply and temperature range set forth herein. Although considered final, these specifications are subject to change, as further product development and data characterization sometimes occur.

# Mouser Electronics

Authorized Distributor

Click to View Pricing, Inventory, Delivery & Lifecycle Information:

[Micron Technology:](#)

[M29W640FB70N6E](#) [M29W640FB70ZA6E](#) [M29W640FT70ZA6E](#) [M29W640FB70ZA6F](#)