

MAX1722/MAX1723/ MAX1724

1.5 μ A I_Q, Step-Up DC-DC Converters in TSOT

General Description

The MAX1722/MAX1723/MAX1724 compact, high-efficiency, step-up DC-DC converters are available in tiny, 5-pin TSOT packages. They feature an extremely low 1.5 μ A quiescent supply current to ensure the highest possible light-load efficiency. Optimized for operation from one to two alkaline or nickel-metal-hydride (NiMH) cells, or a single Li+ cell, these devices are ideal for applications where extremely low quiescent current and ultra-small size are critical.

Built-in synchronous rectification significantly improves efficiency and reduces size and cost by eliminating the need for an external Schottky diode. All three devices feature a 0.5 Ω N-channel power switch. The MAX1722/MAX1724 also feature proprietary noise-reduction circuitry, which suppresses electromagnetic interference (EMI) caused by the inductor in many step-up applications. The family offers different combinations of fixed or adjustable outputs, shutdown, and EMI reduction (see [Selector Guide](#)).

Applications

- Pagers
- Remote Controls
- Remote Wireless Transmitters
- Personal Medical Devices
- Digital Still Cameras
- Single-Cell Battery-Powered Devices
- Low-Power Hand-Held Instruments
- MP3 Players
- Personal Digital Assistants (PDA)

Benefits and Features

- Up to 90% Efficiency
- No External Diode or FETs Needed
- 1.5 μ A Quiescent Supply Current
- 0.1 μ A Logic-Controlled Shutdown
- \pm 1% Output Voltage Accuracy
- Fixed Output Voltage (MAX1724) or Adjustable Output Voltage (MAX1722/MAX1723)
- Up to 150mA Output Current
- 0.8V to 5.5V Input Voltage Range
- 0.91V Guaranteed Startup (MAX1722/MAX1724)
- Internal EMI Suppression (MAX1722/MAX1724)
- TSOT Package (0.9mm typ Height)
- μ DFN Package (2mm x 2mm x 0.75mm)

Ordering Information and [Selector Guide](#) appears at end of data sheet.

Typical Operating Circuit

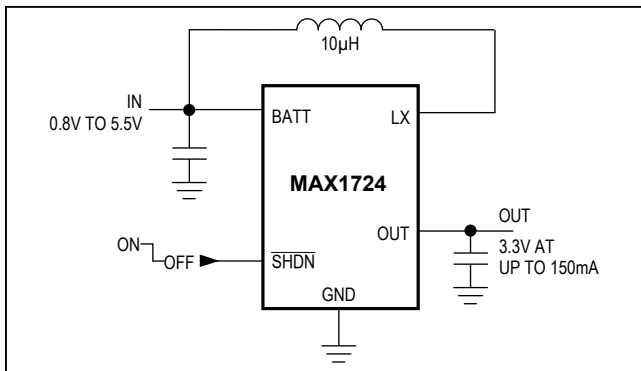

MAX1722/MAX1723/ MAX1724

1.5µA I_Q, Step-Up DC-DC Converters in TSOT

Absolute Maximum Ratings

OUT, SHDN, BATT, LX to GND.....-0.3V to +6V
 FB to GND.....-0.3V to (V_{OUT} + 0.3V)
 OUT, LX Current.....1A
 Continuous Power Dissipation (T_A = +70°C)
 5-Pin Thin SOT (derate 2.7mW/°C above +70°C)...219.10mW

Operating Temperature Range.....-40°C to +85°C
 Junction Temperature.....+150°C
 Storage Temperature Range.....-65°C to +150°C
 Soldering Temperature
 Lead(Pb)-free packages.....+260°C
 Packages containing lead(Pb).....+240°C

Stresses beyond those listed under "Absolute Maximum Ratings" may cause permanent damage to the device. These are stress ratings only, and functional operation of the device at these or any other conditions beyond those indicated in the operational sections of the specifications is not implied. Exposure to absolute maximum rating conditions for extended periods may affect device reliability.

Electrical Characteristics

(V_{BATT} = 1.2V, V_{OUT} = 3.3V (MAX1722/MAX1723), V_{OUT} = V_{OUT(NOM)} (MAX1724), SHDN = OUT, R_L = ∞, T_A = 0°C to +85°C, unless otherwise noted. Typical values are at T_A = +25°C.) (Note 1)

PARAMETER	SYMBOL	CONDITIONS		MIN	TYP	MAX	UNITS
Minimum Input Voltage		MAX1722/MAX1724		0.8			V
Operating Input Voltage	V _{IN}	T _A = +25°C	MAX1722/MAX1724	0.91		5.5	V
			MAX1723 (Note 2)	1.2		5.5	
Minimum Start-Up Input Voltage		T _A = +25°C, R _L = 3kΩ	MAX1722/MAX1724	0.83	0.91		V
			MAX1723 (Note 2)	0.87	1.2		
Output Voltage	V _{OUT}	MAX1724E__27	T _A = +25°C	2.673	2.7	2.727	V
			T _A = 0°C to +85°C	2.633		2.767	
		MAX1724E__30	T _A = +25°C	2.970	3.0	3.030	
			T _A = 0°C to +85°C	2.925		3.075	
		MAX1724E__33	T _A = +25°C	3.267	3.3	3.333	
			T _A = 0°C to +85°C	3.218		3.383	
		MAX1724E__50	T _A = +25°C	4.950	5.0	5.050	
			T _A = 0°C to +85°C	4.875		5.125	
Output Voltage Range	V _{OUT}	MAX1722/MAX1723		2		5.5	V
Feedback Voltage	V _{FB}	MAX1722/MAX1723	T _A = +25°C	1.223	1.235	1.247	V
			T _A = 0°C to +85°C	1.210		1.260	
Feedback Bias Current	I _{FB}	MAX1722/MAX1723	T _A = +25°C		1.5	20	nA
			T _A = +85°C		2.2		
N-Channel On-Resistance	R _{DS(ON)}	V _{OUT} forced to 3.3V			0.5	1.0	Ω
P-Channel On-Resistance	R _{DS(ON)}	V _{OUT} forced to 3.3V			1.0	2.0	Ω
N-Channel Switch Current Limit	I _{LIM}	V _{OUT} forced to 3.3V		400	500	600	mA
Switch Maximum On-Time	t _{ON}			3.5	5	6.5	µs
Synchronous Rectifier Zero-Crossing Current		V _{OUT} forced to 3.3V		5	20	35	mA
Quiescent Current into OUT		(Notes 3, 4)			1.5	3.6	µA
Shutdown Current into OUT		MAX1723/MAX1724 (Notes 3, 4)	T _A = +25°C		0.01	0.5	µA
			T _A = +85°C		0.1		
Quiescent Current into BATT		MAX1722/MAX1724 (Note 4)	T _A = +25°C		0.001	0.5	µA
			T _A = +85°C		0.01		

Electrical Characteristics (continued)

(V_{BATT} = 1.2V, V_{OUT} = 3.3V (MAX1722/MAX1723), V_{OUT} = V_{OUT(NOM)} (MAX1724), $\overline{\text{SHDN}}$ = OUT, R_L = ∞, T_A = 0°C to +85°C, unless otherwise noted. Typical values are at T_A = +25°C.) (Note 1)

PARAMETER	SYMBOL	CONDITIONS	MIN	TYP	MAX	UNITS
Shutdown Current into BATT		MAX1724 (Note 4)	T _A = +25°C	0.001	0.5	µA
			T _A = +85°C	0.01		
$\overline{\text{SHDN}}$ Voltage Threshold	V _{IL}	MAX1723/MAX1724	75	400	mV	
	V _{IH}	MAX1723/MAX1724	500 800			
$\overline{\text{SHDN}}$ Input Bias Current		MAX1723/MAX1724, V _{SHDN} = 5.5V	T _A = +25°C	2	100	nA
			T _A = +85°C	7		

Electrical Characteristics

(V_{BATT} = 1.2V, V_{OUT} = 3.3V (MAX1722/MAX1723), V_{OUT} = V_{OUT(NOM)} (MAX1724), $\overline{\text{SHDN}}$ = OUT, R_L = ∞, T_A = -40°C to +85°C, unless otherwise noted.) (Note 1)

PARAMETER	SYMBOL	CONDITIONS	MIN	TYP	MAX	UNITS
Output Voltage	V _{OUT}	MAX1724E__27	2.633	2.767		V
		MAX1724E__30	2.925	3.075		
		MAX1724E__33	3.218	3.383		
		MAX1724E__50	4.875	5.125		
Output Voltage Range	V _{OUT}	MAX1722/MAX1723	2	5.5		V
Feedback Voltage	V _{FB}	MAX1722/MAX1723	1.200	1.270		V
N-Channel On-Resistance	R _{DS(ON)}	V _{OUT} forced to 3.3V			1.0	Ω
P-Channel On-Resistance	R _{DS(ON)}	V _{OUT} forced to 3.3V			2.0	Ω
N-Channel Switch Current Limit	I _{LIM}	V _{OUT} forced to 3.3V	400	620		mA
Switch Maximum On-Time	t _{ON}		3.5	6.5		µs
Synchronous Rectifier Zero-Crossing Current		V _{OUT} forced to 3.3V	5	35		mA
Quiescent Current into OUT		(Notes 3,4)			3.6	µA
$\overline{\text{SHDN}}$ Voltage Threshold	V _{IL}	MAX1723/MAX1724	75	800		mV
	V _{IH}	MAX1723/MAX1724				

- Note 1:** Limits are 100% production tested at T_A = +25°C. Limits over the operating temperature range are guaranteed by design.
- Note 2:** Guaranteed with the addition of a Schottky MBR0520L external diode between LX and OUT when using the MAX1723 with only one cell, and assumes a 0.3V voltage drop across the Schottky diode (see Figure 3).
- Note 3:** Supply current is measured with an ammeter between the output and OUT pin. This current correlates directly with actual battery supply current, but is reduced in value according to the step-up ratio and efficiency.
- Note 4:** V_{OUT} forced to the following conditions to inhibit switching: V_{OUT} = 1.05 x V_{OUT(NOM)} (MAX1724), V_{OUT} = 3.465V (MAX1722/MAX1723).

Typical Operating Characteristics

(Figure 3 (MAX1723), Figure 7 (MAX1722), Figure 8 (MAX1724), V_{BATT} = V_{IN} = 1.5V, L = 10µH, C_{IN} = 10µF, C_{OUT} = 10µF, T_A = +25°C, unless otherwise noted.)

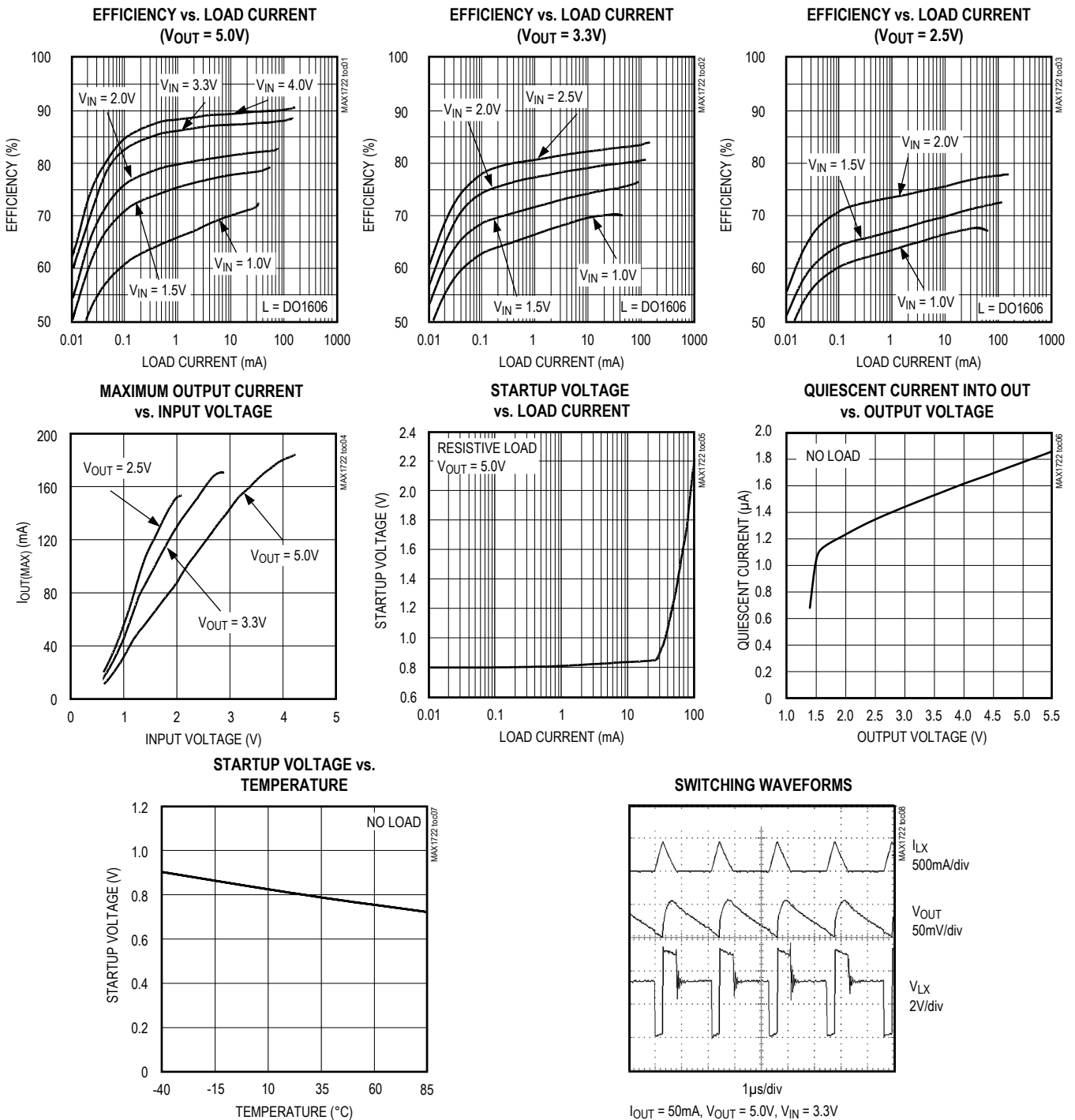

Typical Operating Characteristics (continued)

(Figure 3 (MAX1723), Figure 7 (MAX1722), Figure 8 (MAX1724), V_{BATT} = V_{IN} = 1.5V, L = 10µH, C_{IN} = 10µF, C_{OUT} = 10µF, T_A = +25°C, unless otherwise noted.)

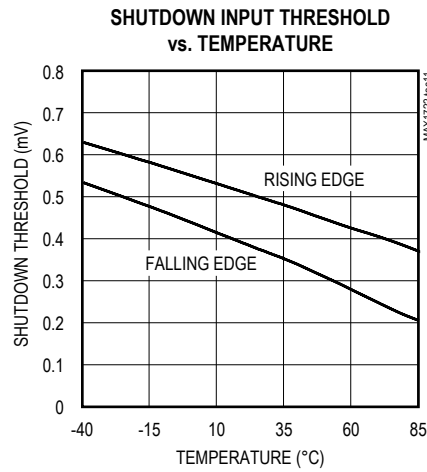
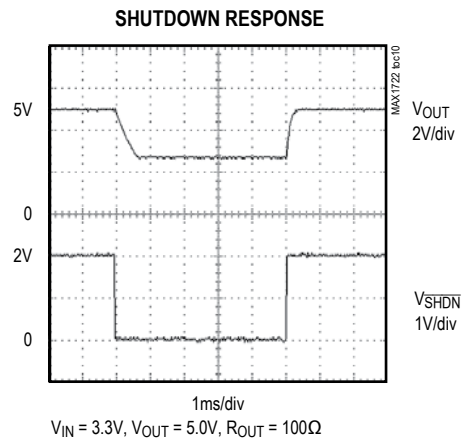
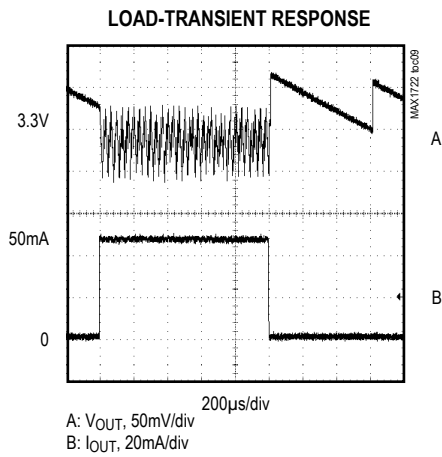

Pin Configurations

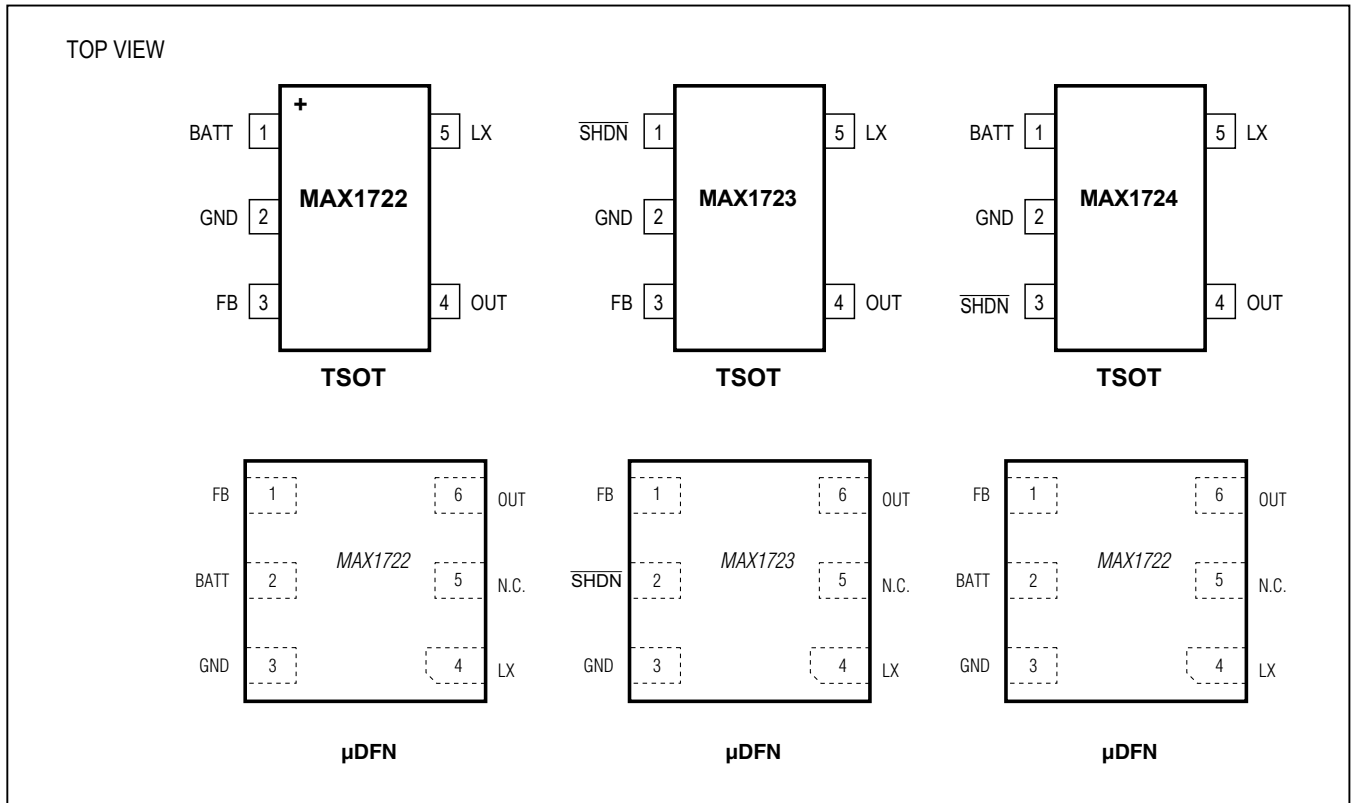

Pin Description

PIN						NAME	FUNCTION
MAX1722	MAX1723	MAX1724	MAX1722	MAX1723	MAX1724		
1	—	1	2	—	2	BATT	Battery Input and Damping Switch Connection
—	1	3	—	2	1	SHDN	Shutdown Input. Drive high for normal operation. Drive low for shutdown.
2	2	2	3	3	3	GND	Ground
3	3	—	1	1	—	FB	Feedback Input to Set Output Voltage. Use a resistor-divider network to adjust the output voltage. See <i>Setting the Output Voltage</i> section.
4	4	4	6	6	6	OUT	Power Output. OUT also provides bootstrap power to the IC.
5	5	5	4	4	4	LX	Internal N-channel MOSFET Switch Drain and P-Channel Synchronous Rectifier Drain
—	—	—	5	5	5	N.C.	No connect.

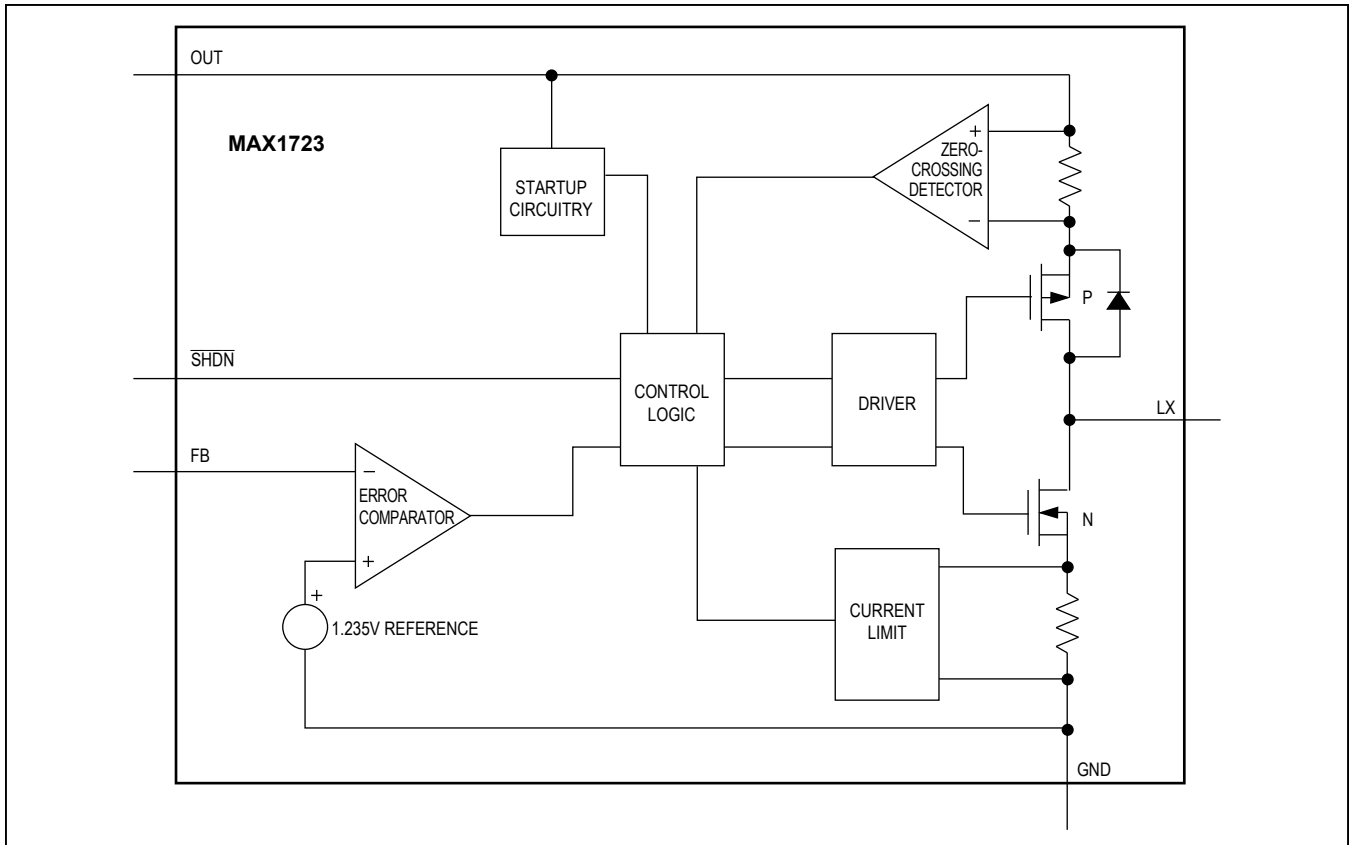

Figure 1. MAX1723 Simplified Functional Diagram

Detailed Description

The MAX1722/MAX1723/MAX1724 compact, high-efficiency, step-up DC-DC converters are guaranteed to start up with voltages as low as 0.91V and operate with an input voltage down to 0.8V. Consuming only 1.5 μ A of quiescent current, these devices include a built-in synchronous rectifier that reduces cost by eliminating the need for an external diode and improves overall efficiency by minimizing losses in the circuit (see *Synchronous Rectification* section). The MAX1722/MAX1724 feature a clamp circuit that reduces EMI due to inductor ringing. The MAX1723/MAX1724 feature an active-low shutdown that reduces quiescent supply current to 0.1 μ A. The MAX1722/MAX1723 have an adjustable output voltage, while the MAX1724 is available with four fixed-output voltage options (see *Selector Guide*). Figure 1 is the MAX1723 simplified functional diagram and Figure 2 is the MAX1724 simplified functional diagram.

PFM Control Scheme

A forced discontinuous, current-limited, pulse-frequency-modulation (PFM) control scheme is a key feature of the

MAX1722/MAX1723/MAX1724. This scheme provides ultra-low quiescent current and high efficiency over a wide output current range. There is no oscillator; the inductor current is limited by the 0.5A N-channel current limit or by the 5 μ s switch maximum on-time. Following each on cycle, the inductor current must ramp to zero before another cycle may start. When the error comparator senses that the output has fallen below the regulation threshold, another cycle begins.

Synchronous Rectification

The internal synchronous rectifier eliminates the need for an external Schottky diode, thus reducing cost and board space. While the inductor discharges, the P-channel MOSFET turns on and shunts the MOSFET body diode. As a result, the rectifier voltage drop is significantly reduced, improving efficiency without the addition of external components.

Low-Voltage Startup Circuit

The MAX1722/MAX1723/MAX1724 contain a low-voltage startup circuit to control DC-DC operation until the output voltage exceeds 1.5V (typ). The minimum start-

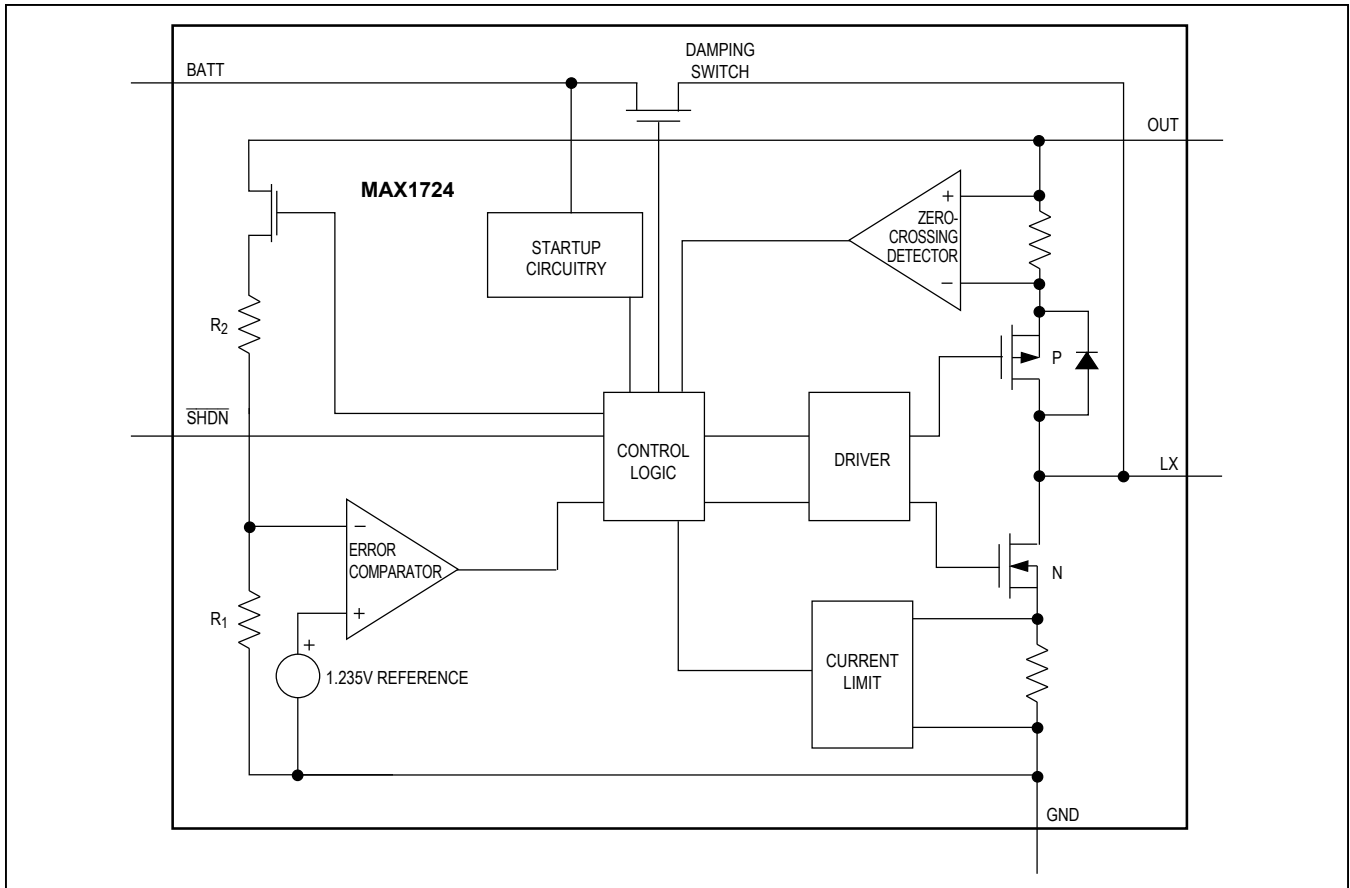

Figure 2. MAX1724 Simplified Functional Diagram

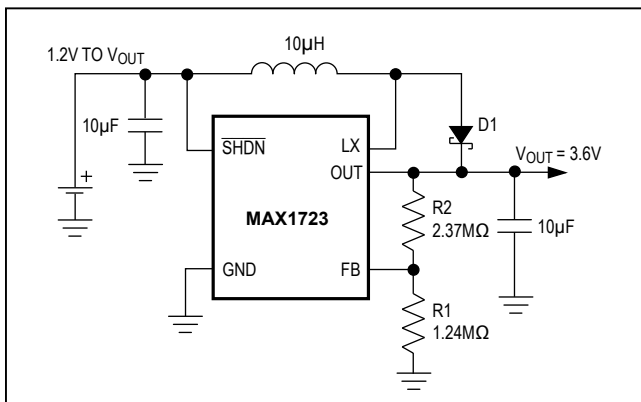

Figure 3. MAX1723 Single-Cell Operation

up voltage is a function of load current (see *Typical Operating Characteristics*). This circuit is powered from the BATT pin for the MAX1722/MAX1724, guaranteeing startup at input voltages as low as 0.91V. The MAX1723

lacks a BATT pin; therefore, this circuit is powered through the OUT pin. Adding a Schottky diode in parallel with the P-channel synchronous rectifier allows for startup voltages as low as 1.2V for the MAX1723 (Figure 3). The external Schottky diode is not needed for input voltages greater than 1.8V. Once started, the output maintains the load as the battery voltage decreases below the startup voltage.

Shutdown (MAX1723/MAX1724)

The MAX1723/MAX1724 enter shutdown when the $\overline{\text{SHDN}}$ pin is driven low. During shutdown, the body diode of the P-channel MOSFET allows current to flow from the battery to the output. V_{OUT} falls to approximately V_{IN} - 0.6V and LX remains high impedance. Shutdown can be pulled as high as 6V, regardless of the voltage at BATT or OUT. For normal operation, connect SHDN to the input.

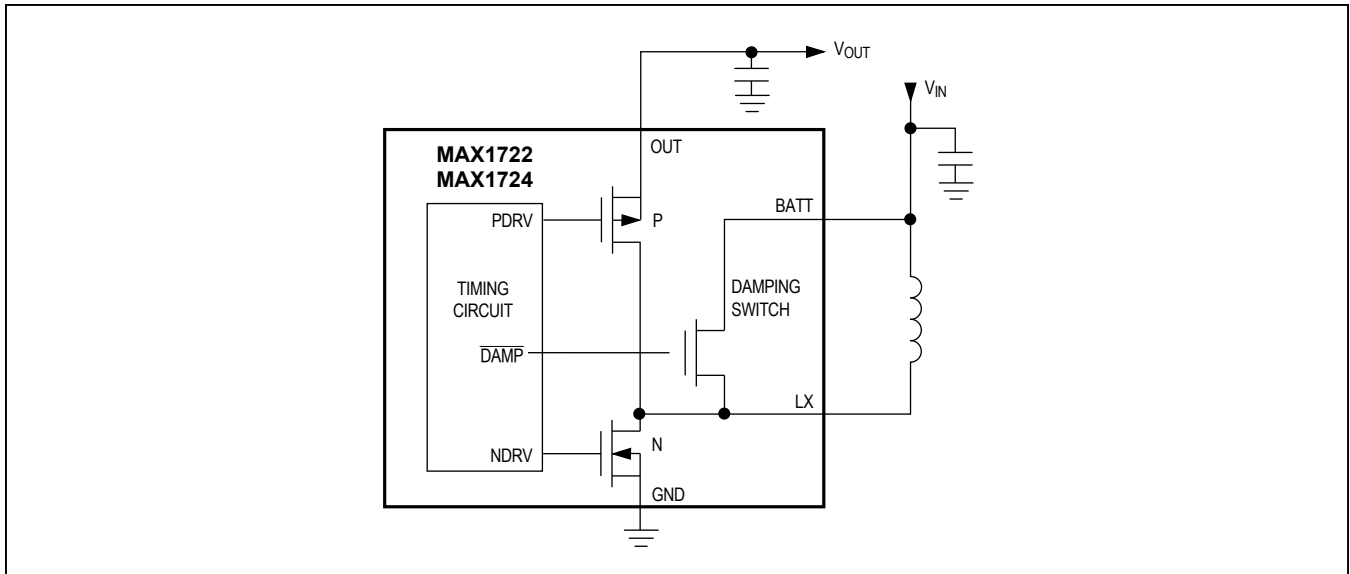

Figure 4. Simplified Diagram of Damping Switch

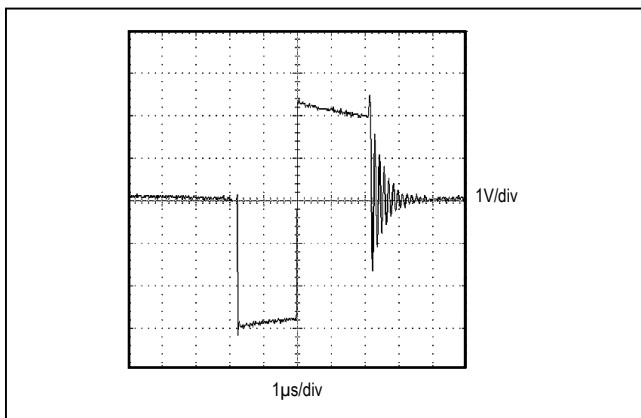

Figure 5. LX Ringing Without Damping Switch (MAX1723)

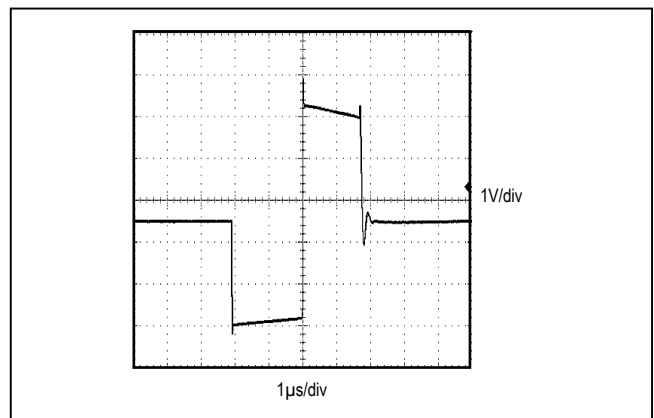

Figure 6. LX Ringing With Damping Switch (MAX1722/MAX1724)

BATT/Damping Switch (MAX1722/MAX1724)

The MAX1722/MAX1724 include an internal damping switch (Figure 4) to minimize ringing at LX and reduce EMI. When the energy in the inductor is insufficient to supply current to the output, the capacitance and inductance at LX form a resonant circuit that causes ringing. The damping switch supplies a path to quickly dissipate this energy, suppressing the ringing at LX. This does not reduce the output ripple, but does reduce EMI with minimal impact on efficiency. Figures 5 and 6 show the LX node voltage waveform without and with the damping switch, respectively.

Design Procedure

Setting the Output Voltage (MAX1722/MAX1723)

The output voltage can be adjusted from 2V to 5.5V using external resistors R1 and R2 (Figure 7). Since FB leakage is 20nA (max), select feedback resistor R1 in the 100kΩ to 1MΩ range. Calculate R2 as follows:

$$R2 = R1 \left(\frac{V_{OUT}}{V_{FB}} - 1 \right)$$

where $V_{FB} = 1.235V$.

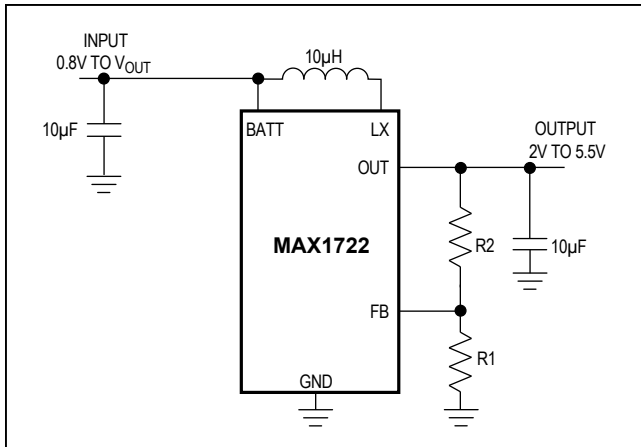

Figure 7. Adjustable Output Circuit

Inductor Selection

The control scheme of the MAX1722/MAX1723/MAX1724 permits flexibility in choosing an inductor. A 10µH inductor value performs well in most applications. Smaller inductance values typically offer smaller physical size for a given series resistance, allowing the smallest overall circuit dimensions. Circuits using larger inductance values may start up at lower battery voltages, provide higher efficiency, and exhibit less ripple, but they may reduce the maximum output current. This occurs when the inductance is sufficiently large to prevent the maximum current limit (I_{LIM}) from being reached before the maximum on-time ($t_{ON(MAX)}$) expires.

Table 1. Suggested Inductors and Suppliers

MANUFACTURER	INDUCTOR	PHONE WEBSITE
Coilcraft	DO1608 Series DO1606 Series	847-639-2361 www.coilcraft.com
Murata	LQH4C Series	770-436-1300 www.murata.com
Sumida	CDRH4D18 Series CR32 Series CMD4D06 Series	847-545-6700 www.sumida.com
Sumitomo/ Daidoo Electronics	CXLD140 Series	+81 (06) 6355-5733 www.daidoo.co.jp
Toko	3DF Type D412F Type	847-297-0070 www.toko.com

For maximum output current, choose the inductor value so that the controller reaches the current-limit before the maximum on-time is triggered:

$$L < \frac{V_{BATT} t_{ON(MAX)}}{I_{LIM}}$$

where the maximum on-time is typically 5µs, and the current limit (I_{LIM}) is typically 500mA (see *Electrical Characteristics* table).

For larger inductor values, determine the peak inductor current (I_{PEAK}) by:

$$I_{PEAK} = \frac{V_{BATT} t_{ON(MAX)}}{L}$$

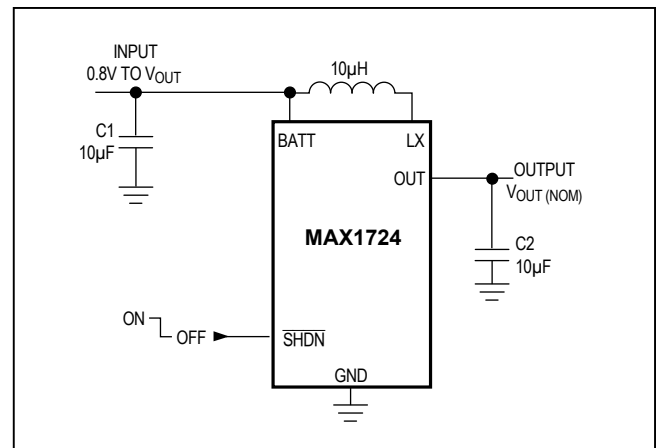

Figure 8. MAX1724 Standard Application Circuit

The inductor's incremental saturation current rating should be greater than the peak switching current. However, it is generally acceptable to bias the inductor into saturation by as much as 20%, although this will slightly reduce efficiency. Table 1 lists suggested inductors and suppliers.

Maximum Output Current

The maximum output current depends on the peak inductor current, the input voltage, the output voltage, and the overall efficiency (η):

$$I_{OUT(MAX)} = \frac{1}{2} I_{PEAK} \left(\frac{V_{BATT}}{V_{OUT}} \right) \eta$$

Table 2. Suggested Surface-Mount Capacitors and Manufacturers (C1 and C2)

MANUFACTURER	CAPACITOR VALUE	DESCRIPTION	PHONE WEBSITE
AVX	1µF to 10µF	X7R Ceramic	843-448-9411 www.avxcorp.com
	10µF to 330µF	TAJ Tantalum Series TPS Tantalum Series	
Kemet	1µF to 22µF	X5R/X7R Ceramic	864-963-6300 www.kemet.com
	10µF to 330µF	T494 Tantalum Series	
	68µF to 330µF	T520 Tantalum Series	
Sanyo	33µF to 330µF	TPC Polymer Series	408-749-9714 www.secc.co.jp
Taiyo Yuden	33µF to 330µF	X5R/X7R Ceramic	800-368-2496 www.t-yuden.org
TDK	1µF to 10µF	X7R Ceramic	847-803-6100 www.tdk.com
Vishay Sprague	10µF to 330µF	594D Tantalum Series 595D Tantalum Series	203-452-5664 www.vishay.com

For most applications, the peak inductor current equals the current limit. However, for applications using large inductor values or low input voltages, the maximum ontime limits the peak inductor current (see *Inductor Selection* section).

Capacitor Selection

Choose input and output capacitors to supply the input and output peak currents with acceptable voltage ripple. The input filter capacitor (C_{IN}) reduces peak currents drawn from the battery and improves efficiency. Low equivalent series resistance (ESR) capacitors are recommended. Ceramic capacitors have the lowest ESR, but low ESR tantalum or polymer capacitors offer a good balance between cost and performance.

Output voltage ripple has two components: variations in the charge stored in the output capacitor with each LX pulse, and the voltage drop across the capacitor's ESR caused by the current into and out of the capacitor:

$$V_{\text{RIPPLE}} = V_{\text{RIPPLE}(C)} + V_{\text{RIPPLE}(ESR)}$$

$$V_{\text{RIPPLE}(ESR)} \approx I_{\text{PEAK}} R_{\text{ESR}(C_{\text{OUT}})}$$

$$V_{\text{RIPPLE}(C)} \approx \frac{1}{2} \left(\frac{L}{(V_{\text{OUT}} - V_{\text{BATT}}) C_{\text{OUT}}} \right) (I_{\text{PEAK}}^2 - I_{\text{OUT}}^2)$$

where I_{PEAK} is the peak inductor current (see *Inductor Selection* section). For ceramic capacitors, the output voltage ripple is typically dominated by V_{RIPPLE(C)}. For example, a 10µF ceramic capacitor and a 10µH inductor typically provide 75mV of output ripple when stepping up from 3.3V to 5V at 50mA. Low input-to-output voltage differences (i.e. two cells to 3.3V) require higher output capacitor values.

Capacitance and ESR variation of temperature should be considered for best performance in applications with wide operating temperature ranges. Table 2 lists suggested capacitors and suppliers.

PC Board Layout Considerations

Careful PC board layout is important for minimizing ground bounce and noise. Keep the IC's GND pin and the ground leads of the input and output capacitors less than 0.2in (5mm) apart using a ground plane. In addition, keep all connections to FB (MAX1722/MAX1723 only) and LX as short as possible.

Selector Guide

PART	OUTPUT (V)	$\overline{\text{SHDN}}$	LX DAMPING
MAX1722EZK	Adjustable	No	Yes
MAX1723EZK	Adjustable	Yes	No
MAX1724EZK27	Fixed 2.7	Yes	Yes
MAX1724EZK30	Fixed 3.0	Yes	Yes
MAX1724EZK33	Fixed 3.3	Yes	Yes
MAX1724EZK50	Fixed 5.0	Yes	Yes
MAX1722ELT	Adjustable	No	Yes
MAX1723ELT	Adjustable	Yes	No
MAX1724ELT27	Fixed 2.7	Yes	Yes
MAX1724ELT30	Fixed 3.0	Yes	Yes
MAX1724ELT33	Fixed 3.3	Yes	Yes
MAX1724ELT50	Fixed 5.0	Yes	Yes

Package Information

For the latest package outline information and land patterns (footprints), go to www.maximintegrated.com/packages. Note that a "+", "#", or "-" in the package code indicates RoHS status only. Package drawings may show a different suffix character, but the drawing pertains to the package regardless of RoHS status.

PACKAGE TYPE	PACKAGE CODE	OUTLINE NO.	LAND PATTERN NO.
TSOT	Z5+1	21-0113	90-0241
µDFN	L622+1	21-0164	90-0004

Ordering Information

PART	TEMP RANGE	PIN-PACKAGE	TOP MARK
MAX1722EZK+T+	-40°C to +85°C	5 TSOT	ADQF
MAX1723EZK+T	-40°C to +85°C	5 TSOT	ADQG
MAX1724EZK27+T	-40°C to +85°C	5 TSOT	ADQH
MAX1724EZK30+T	-40°C to +85°C	5 TSOT	ADQI
MAX1724EZK33+T	-40°C to +85°C	5 TSOT	ADQJ
MAX1724EZK50+T	-40°C to +85°C	5 TSOT	ADQK
MAX1722ELT+T+	-40°C to +85°C	6 µDFN	ADH
MAX1723ELT+T	-40°C to +85°C	6 µDFN	ADI
MAX1724 ELT+T	-40°C to +85°C	6 µDFN	ADJ
MAX1724ELT27+T	-40°C to +85°C	6 µDFN	ADK
MAX1724ELT33+T	-40°C to +85°C	6 µDFN	ADL
MAX1724ELT50+T	-40°C to +85°C	6 µDFN	ADM

+Denotes a lead(Pb)-free/RoHS-compliant package.
T = Tape and reel.

Revision History

REVISION NUMBER	REVISION DATE	DESCRIPTION	PAGES CHANGED
0	7/01	Initial release	—
1	9/12	Added lead-free and tape-and-reel designations and added soldering temperatures	1, 2
2	5/13	Corrected package and thermal information in <i>Feature, Ordering Information, Absolute Maximum Ratings, Pin Configuration, and Package Information</i>	1, 2, 11
3	12/15	Added 2 x 2 μ DFN package	1-3, 5, 11

For pricing, delivery, and ordering information, please contact Maxim Direct at 1-888-629-4642, or visit Maxim Integrated's website at www.maximintegrated.com.

Maxim Integrated cannot assume responsibility for use of any circuitry other than circuitry entirely embodied in a Maxim Integrated product. No circuit patent licenses are implied. Maxim Integrated reserves the right to change the circuitry and specifications without notice at any time. The parametric values (min and max limits) shown in the Electrical Characteristics table are guaranteed. Other parametric values quoted in this data sheet are provided for guidance.