

FEATURES

- **Controlled Baseline**
 - One Assembly/Test Site, One Fabrication Site
- **Extended Temperature Performance of -55°C to 125°C**
- **Enhanced Diminishing Manufacturing Sources (DMS) Support**
- **Enhanced Product-Change Notification**
- **Qualification Pedigree ⁽¹⁾**
- **Single-Chip and Single-Supply Interface for IBM™ PC/AT™ Serial Port**
- **RS-232 Bus-Pin ESD Protection Exceeds ± 15 kV Using Human-Body Model (HBM)**
- **D Meets or Exceeds the Requirements of TIA/EIA-232-F and ITU v.28 Standards**
- **Operates With 3-V to 5.5-V V_{CC} Supply**
- **Three Drivers and Five Receivers**
- **Low Standby Current . . . 1 mA Typical**
- **External Capacitors . . . 4×0.1 mF**
- **Accepts 5-V Logic Input With 3.3-V Supply**
- **Always-Active Noninverting Receiver Output (ROUT2B)**
- **Serial-Mouse Driveability**
- **Auto-Powerdown Feature to Disable Driver Outputs When No Valid RS-232 Signal Is Sensed**

(1) Component qualification in accordance with JEDEC and industry standards to ensure reliable operation over an extended temperature range. This includes, but is not limited to, Highly Accelerated Stress Test (HAST) or biased 85/85, temperature cycle, autoclave or unbiased HAST, electromigration, bond intermetallic life, and mold compound life. Such qualification testing should not be viewed as justifying use of this component beyond specified performance and environmental limits.

DESCRIPTION

The MAX3243 consists of three line drivers, five line receivers, and a dual charge-pump circuit with ± 15 -kV ESD (HBM) protection pin to pin (serial-port connection pins, including GND). The device meets the requirements of TIA/EIA-232-F and provides the electrical interface between an asynchronous communication controller and the serial-port connector. This combination of drivers and receivers matches that needed for the typical serial port used in an IBM PC/AT or compatible. The charge pump and four small external capacitors allow operation from a single 3-V to 5.5-V supply. In addition, the device includes an always-active noninverting output (ROUT2B), which allows applications using the ring indicator to transmit data while the device is powered down.

- **Applications**
 - Battery-Powered Systems, PDAs, Notebooks, Laptops, Palmtop PCs, and Hand-Held Equipment

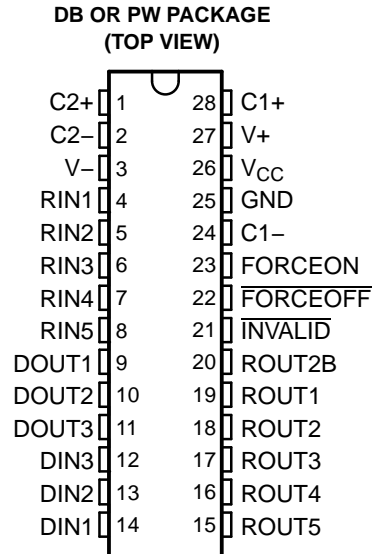

Please be aware that an important notice concerning availability, standard warranty, and use in critical applications of Texas Instruments semiconductor products and disclaimers thereto appears at the end of this data sheet.

IBM, PC/AT are trademarks of IBM.

MAX3243-EP
3-V TO 5.5-V MULTICHANNEL RS-232 LINE DRIVER/RECEIVER
WITH ±15-kV ESD (HBM) PROTECTION



SGLS328A—MARCH 2006—REVISED MAY 2006

Flexible control options for power management are available when the serial port is inactive. The auto-powerdown feature functions when FORCEON is low and FORCEOFF is high. During this mode of operation, if the device does not sense a valid RS-232 signal, the driver outputs are disabled. If FORCEOFF is set low, both drivers and receivers (except ROUT2B) are shut off and the supply current is reduced to 1 µA. Disconnecting the serial port or turning off the peripheral drivers causes the auto-powerdown condition to occur.

Auto-powerdown can be disabled when FORCEON and FORCEOFF are high and should be done when driving a serial mouse. With auto-powerdown enabled, the device is activated automatically when a valid signal is applied to any receiver input. The INVALID output is used to notify the user if an RS-232 signal is present at any receiver input. INVALID is high (valid data) if any receiver input voltage is greater than 2.7 V or less than -2.7 V or has been between -0.3 V and 0.3 V for less than 30 µs. INVALID is low (invalid data) if all receiver input voltages are between -0.3 V and 0.3 V for more than 30 µs. See Figure 5 for receiver input levels.

ORDERING INFORMATION

| T _A | PACKAGE ⁽¹⁾ | | ORDERABLE PART NUMBER | TOP-SIDE MARKING |
|----------------|------------------------|--------------|-----------------------|------------------|
| -55°C to 125°C | SSOP – DB | Reel of 2000 | MAX3243MDBREP | MB3243M |
| | TSSOP – PW | Reel of 2000 | MAX3243MPWREP | MB3243M |

(1) Package drawings, standard packing quantities, thermal data, symbolization, and PCB design guidelines are available at www.ti.com/sc/package.

FUNCTION TABLES

Each Driver⁽¹⁾

| INPUTS | | | | OUTPUT DOUT | DRIVER STATUS |
|--------|---------|----------|------------------------|-------------|-----------------------------------------------|
| DIN | FORCEON | FORCEOFF | VALID RIN RS-232 LEVEL | | |
| X | X | L | X | Z | Powered off |
| L | H | H | X | H | Normal operation with auto-powerdown disabled |
| H | H | H | X | L | |
| L | L | H | YES | H | Normal operation with auto-powerdown enabled |
| H | L | H | YES | L | |
| L | L | H | NO | Z | Power off by auto-powerdown feature |
| H | L | H | NO | Z | |

(1) H = high level, L = low level, X = irrelevant, Z = high impedance

Each Receiver⁽¹⁾

| INPUTS | | | | OUTPUTS | | RECEIVER STATUS |
|--------|-----------------|----------|------------------------|---------|------|-------------------------------------------------------|
| RIN2 | RIN1, RIN3–RIN5 | FORCEOFF | VALID RIN RS-232 LEVEL | ROUT2B | ROUT | |
| L | X | L | X | L | Z | Powered off while ROUT2B is active |
| H | X | L | X | H | Z | |
| L | L | H | YES | L | H | Normal operation with auto-powerdown disabled/enabled |
| L | H | H | YES | L | L | |
| H | L | H | YES | H | H | |
| H | H | H | YES | H | L | |
| Open | Open | H | YES | L | H | |

(1) H = high level, L = low level, X = irrelevant, Z = high impedance (off), Open = input disconnected or connected driver off

LOGIC DIAGRAM (POSITIVE LOGIC)

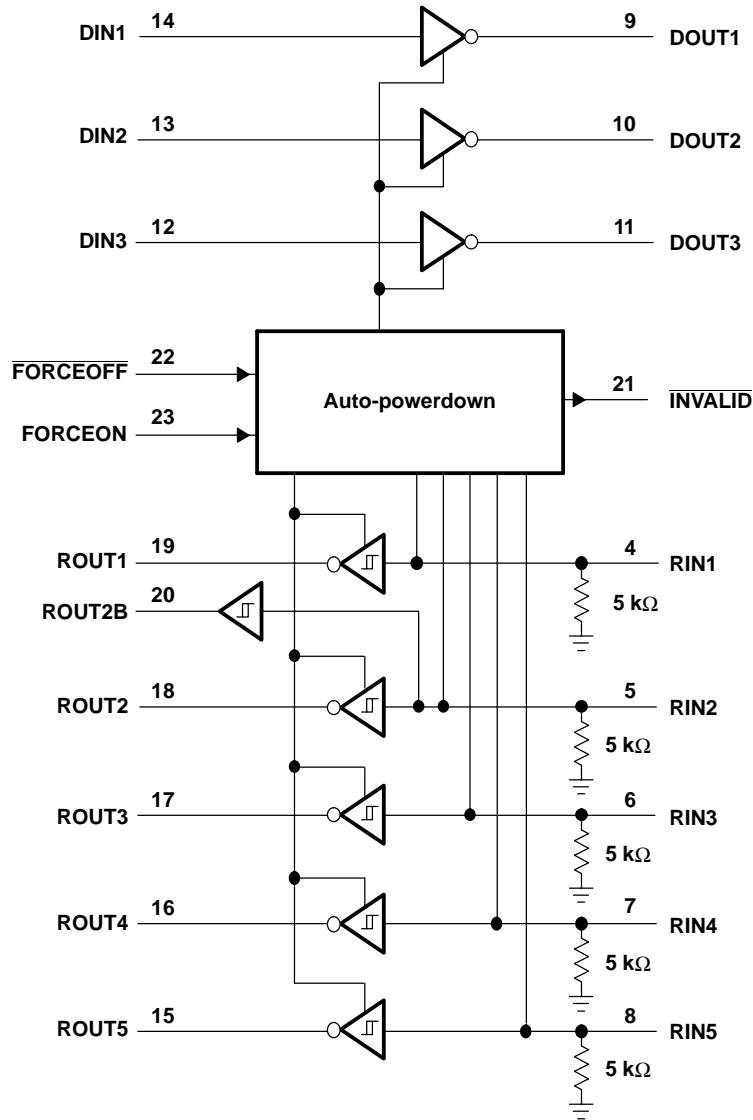

MAX3243-EP

3-V TO 5.5-V MULTICHANNEL RS-232 LINE DRIVER/RECEIVER

WITH ± 15 -kV ESD (HBM) PROTECTION

SGLS328A—MARCH 2006—REVISED MAY 2006

Absolute Maximum Ratings⁽¹⁾

over operating free-air temperature range (unless otherwise noted)

| | | MIN | MAX | UNIT |
|------------------|-----------------------------------------------------|----------------------------|-----|------|
| V _{CC} | Supply voltage range ⁽²⁾ | -0.3 | 6 | V |
| V+ | Positive output supply voltage range ⁽²⁾ | -0.3 | 7 | V |
| V- | Negative output supply voltage range ⁽²⁾ | 0.3 | -7 | V |
| V+ - V- | Supply voltage difference ⁽²⁾ | | 13 | V |
| V _I | Input voltage range | Driver (FORCEOFF, FORCEON) | | V |
| | | | | |
| V _O | Output voltage range | Driver | | V |
| | | | | |
| θ_{JA} | Package thermal impedance ⁽³⁾⁽⁴⁾ | DB package | | °C/W |
| | | DW package | | |
| | | PW package | | |
| T _J | Operating virtual junction temperature | | 150 | °C |
| T _{stg} | Storage temperature range | -65 | 150 | °C |

- Stresses beyond those listed under "absolute maximum ratings" may cause permanent damage to the device. These are stress ratings only, and functional operation of the device at these or any other conditions beyond those indicated under "recommended operating conditions" is not implied. Exposure to absolute-maximum-rated conditions for extended periods may affect device reliability.
- All voltages are with respect to network GND.
- Maximum power dissipation is a function of T_J(max), θ_{JA} , and T_A. The maximum allowable power dissipation at any allowable ambient temperature is P_D = (T_J(max) - T_A)/ θ_{JA} . Operating at the absolute maximum T_J of 150°C can affect reliability.
- The package thermal impedance is calculated in accordance with JESD 51-7.

Recommended Operating Conditions⁽¹⁾

See [Figure 6](#)

| | | MIN | NOM | MAX | UNIT |
|-------------------------------------------------------------|-------------------------|-------------------------|-----|-----|------|
| Supply voltage | V _{CC} = 3.3 V | 3 | 3.3 | 3.6 | V |
| | V _{CC} = 5 V | 4.5 | 5 | 5.5 | |
| V _{IH} Driver and control high-level input voltage | DIN, FORCEOFF, FORCEON | V _{CC} = 3.3 V | 2 | | V |
| | | V _{CC} = 5 V | 2.4 | | |
| V _{IL} Driver and control low-level input voltage | DIN, FORCEOFF, FORCEON | | | 0.8 | V |
| V _I Driver and control input voltage | DIN, FORCEOFF, FORCEON | 0 | | 5.5 | V |
| V _I Receiver input voltage | | -25 | | 25 | V |
| T _A Operating free-air temperature | | -55 | | 125 | °C |

- Test conditions are C1–C4 = 0.1 μ F at V_{CC} = 3.3 V \pm 0.3 V; C1 = 0.047 μ F, C2–C4 = 0.33 μ F at V_{CC} = 5 V \pm 0.5 V.

Electrical Characteristics⁽¹⁾

over recommended ranges of supply voltage and operating free-air temperature (unless otherwise noted) (see [Figure 6](#))

| PARAMETER | | TEST CONDITIONS | MIN | TYP ⁽²⁾ | MAX | UNIT |
|-----------------|----------------------------------------|-------------------------|-----------------------------------------------------------------------------------------------------------|--------------------|---------|---------|
| I _I | Input leakage current | FORCEOFF, FORCEON | | ± 0.01 | ± 1 | μ A |
| I _{CC} | Supply current (T _A = 25°C) | Auto-powerdown disabled | No load, FORCEOFF and FORCEON at V _{CC} | 0.3 | 2 | mA |
| | | Powered off | No load, FORCEOFF at GND | 1 | 10 | |
| | | Auto-powerdown enabled | No load, FORCEOFF at V _{CC} , FORCEON at GND, All RIN are open or grounded, All DIN are grounded | 1 | 20 | μ A |

- Test conditions are C1–C4 = 0.1 μ F at V_{CC} = 3.3 V \pm 0.3 V; C1 = 0.047 μ F, C2–C4 = 0.33 μ F at V_{CC} = 5 V \pm 0.5 V.
- Stresses beyond those listed under "absolute maximum ratings" may cause permanent damage to the device. These are stress ratings only, and functional operation of the device at these or any other conditions beyond those indicated under "recommended operating conditions" is not implied. Exposure to absolute-maximum-rated conditions for extended periods may affect device reliability.

DRIVER SECTION

Electrical Characteristics⁽¹⁾

over recommended ranges of supply voltage and operating free-air temperature (unless otherwise noted) (see Figure 6)

| PARAMETER | TEST CONDITIONS | MIN | TYP ⁽²⁾ | MAX | UNIT |
|------------------|-----------------------------------------------------------------------------------------------------------------------------------------|-------------------------------------------------------------|--------------------|----------|----------|
| V _{OH} | High-level output voltage All DOUT at R _L = 3 k Ω to GND | 5 | 5.4 | | V |
| V _{OL} | Low-level output voltage All DOUT at R _L = 3 k Ω to GND | -5 | -5.4 | | V |
| V _O | Output voltage (mouse driveability) DIN1 = DIN2 = GND, DIN3 = V _{CC} , 3-k Ω to GND at DOUT3, DOUT1 = DOUT2 = 2.5 mA | | ± 5 | | V |
| I _{IH} | High-level input current V _I = V _{CC} | | ± 0.01 | ± 1 | μ A |
| I _{IL} | Low-level input current V _I at GND | | ± 0.01 | ± 1 | μ A |
| V _{hys} | Input hysteresis | | | ± 1 | V |
| I _{OS} | Short-circuit output current ⁽³⁾ V _{CC} = 3.6 V, V _O = 0 V | | ± 35 | ± 60 | mA |
| | V _{CC} = 5.5 V, V _O = 0 V | | | | |
| r _o | Output resistance V _{CC} , V+, and V- = 0 V, V _O = ± 2 V | 300 | 10M | | Ω |
| I _{off} | Output leakage current FORCEOFF = GND, | V _O = ± 12 V, V _{CC} = 3 to 3.6 V | | ± 25 | μ A |
| | | V _O = ± 10 V, V _{CC} = 4.5 to 5.5 V | | ± 25 | |

(1) Test conditions are C1–C4 = 0.1 μ F at V_{CC} = 3.3 V \pm 0.3 V; C1 = 0.047 μ F, C2–C4 = 0.33 μ F at V_{CC} = 5 V \pm 0.5 V.

(2) All typical values are at V_{CC} = 3.3 V or V_{CC} = 5 V and T_A = 25°C.

(3) Short-circuit durations should be controlled to prevent exceeding the device absolute power dissipation ratings, and not more than one output should be shorted at a time.

Switching Characteristics⁽¹⁾

over recommended ranges of supply voltage and operating free-air temperature (unless otherwise noted) (see Figure 6)

| PARAMETER | TEST CONDITIONS | MIN | TYP ⁽²⁾ | MAX | UNIT |
|--------------------|----------------------------------------------------------------------------------------------------------------------------------|------------------------------------|--------------------|-----|------------|
| Maximum data rate | C _L = 1000 pF, One DOUT switching, R _L = 3 k Ω , See Figure 1 | 150 | 250 | | kbit/s |
| t _{sk(p)} | Pulse skew ⁽³⁾ C _L = 150 pF to 2500 pF, R _L = 3 k Ω to 7 k Ω , See Figure 2 | | 100 | | ns |
| SR _(tr) | Slew rate, transition region (see Figure 1) V _{CC} = 3.3 V, R _L = 3 k Ω to 7 k Ω | C _L = 150 pF to 1000 pF | 6 | 30 | V/ μ s |
| | | C _L = 150 pF to 2500 pF | 4 | 30 | |

(1) Test conditions are C1–C4 = 0.1 μ F at V_{CC} = 3.3 V \pm 0.3 V; C1 = 0.047 μ F, C2–C4 = 0.33 μ F at V_{CC} = 5 V \pm 0.5 V.

(2) All typical values are at V_{CC} = 3.3 V or V_{CC} = 5 V and T_A = 25°C.

(3) Pulse skew is defined as |t_{PLH} - t_{PHL}| of each channel of the same device.

RECEIVER SECTION

Electrical Characteristics⁽¹⁾

over recommended ranges of supply voltage and operating free-air temperature (unless otherwise noted) (see Figure 6)

| PARAMETER | TEST CONDITIONS | MIN | TYP ⁽²⁾ | MAX | UNIT |
|------------------|-------------------------------------------------------------------|-----------------------|-----------------------|-----|------|
| V _{OH} | High-level output voltage I _{OH} = -1 mA | V _{CC} - 0.6 | V _{CC} - 0.1 | | V |
| V _{OL} | Low-level output voltage I _{OH} = 1.6 mA | | | 0.4 | V |
| V _{IT+} | Positive-going input threshold voltage V _{CC} = 3.3 V | | 1.6 | 2.4 | V |
| | | V _{CC} = 5 V | 1.9 | 2.4 | |
| V _{IT-} | Negative-going input threshold voltage V _{CC} = 3.3 V | | 0.6 | 1.1 | V |
| | | V _{CC} = 5 V | 0.8 | 1.4 | |
| V _{hys} | Input hysteresis (V _{IT+} - V _{IT-}) | | 0.5 | | V |

(1) Test conditions are C1–C4 = 0.1 μ F at V_{CC} = 3.3 V \pm 0.3 V; C1 = 0.047 μ F, C2–C4 = 0.33 μ F at V_{CC} = 5 V \pm 0.5 V.

(2) All typical values are at V_{CC} = 3.3 V or V_{CC} = 5 V and T_A = 25°C.

MAX3243-EP

3-V TO 5.5-V MULTICHANNEL RS-232 LINE DRIVER/RECEIVER

WITH ± 15 -kV ESD (HBM) PROTECTION

SGLS328A—MARCH 2006—REVISED MAY 2006

Electrical Characteristics (continued)

over recommended ranges of supply voltage and operating free-air temperature (unless otherwise noted) (see [Figure 6](#))

| PARAMETER | TEST CONDITIONS | MIN | TYP ⁽²⁾ | MAX | UNIT |
|--------------------------------------------------|-----------------------------------------------|-----|--------------------|----------|------------------|
| I_{off} Output leakage current (except ROUT2B) | FORCEOFF = 0 V | | ± 0.05 | ± 10 | μA |
| r_i Input resistance | $V_i = \pm 3 \text{ V}$ or $\pm 25 \text{ V}$ | 3 | 5 | 8 | $\text{k}\Omega$ |

Switching Characteristics⁽¹⁾

over recommended ranges of supply voltage and operating free-air temperature (unless otherwise noted)

| PARAMETER | TEST CONDITIONS | TYP ⁽²⁾ | UNIT |
|-------------------------------------------------------------|-----------------------------------------------------------------------------------|--------------------|------|
| t_{PLH} Propagation delay time, low- to high-level output | $C_L = 150 \text{ pF}$, See Figure 3 | 150 | ns |
| t_{PHL} Propagation delay time, high- to low-level output | | 150 | ns |
| t_{en} Output enable time | $C_L = 150 \text{ pF}$, $R_L = 3 \text{ k}\Omega$, See Figure 4 | 200 | ns |
| t_{dis} Output disable time | | 200 | ns |
| $t_{sk(p)}$ Pulse skew ⁽³⁾ | See Figure 3 | 50 | ns |

(1) Test conditions are C1–C4 = 0.1 μF at $V_{CC} = 3.3 \text{ V} \pm 0.3 \text{ V}$; C1 = 0.047 μF , C2–C4 = 0.33 μF at $V_{CC} = 5 \text{ V} \pm 0.5 \text{ V}$.

(2) All typical values are at $V_{CC} = 3.3 \text{ V}$ or $V_{CC} = 5 \text{ V}$ and $T_A = 25^\circ\text{C}$.

(3) Pulse skew is defined as $|t_{PLH} - t_{PHL}|$ of each channel of the same device.

AUTO-POWERDOWN SECTION

Electrical Characteristics

over recommended ranges of supply voltage and operating free-air temperature (unless otherwise noted) (see [Figure 5](#))

| PARAMETER | TEST CONDITIONS | MIN | MAX | UNIT |
|-----------------------------------------------------------------------------------------------------|----------------------------------------------------------------|----------------|-----|------|
| $V_{IT+(valid)}$ Receiver input threshold for $\overline{\text{INVALID}}$ high-level output voltage | FORCEON = GND, FORCEOFF = V_{CC} | | 2.7 | V |
| $V_{IT-(valid)}$ Receiver input threshold for $\overline{\text{INVALID}}$ high-level output voltage | FORCEON = GND, FORCEOFF = V_{CC} | -2.7 | | V |
| $V_{T(invalid)}$ Receiver input threshold for $\overline{\text{INVALID}}$ low-level output voltage | FORCEON = GND, FORCEOFF = V_{CC} | -0.3 | 0.3 | V |
| V_{OH} $\overline{\text{INVALID}}$ high-level output voltage | $I_{OH} = -1 \text{ mA}$, FORCEON = GND, FORCEOFF = V_{CC} | $V_{CC} - 0.6$ | | V |
| V_{OL} $\overline{\text{INVALID}}$ low-level output voltage | $I_{OL} = 1.6 \text{ mA}$, FORCEON = GND, FORCEOFF = V_{CC} | | 0.4 | V |

Switching Characteristics

over recommended ranges of supply voltage and operating free-air temperature (unless otherwise noted) (see [Figure 5](#))

| PARAMETER | TEST CONDITIONS | TYP ⁽¹⁾ | UNIT |
|-----------------------------------------------------------------|------------------------|--------------------|---------------|
| t_{valid} Propagation delay time, low- to high-level output | $V_{CC} = 5 \text{ V}$ | 1 | μs |
| $t_{invalid}$ Propagation delay time, high- to low-level output | $V_{CC} = 5 \text{ V}$ | 30 | μs |
| t_{en} Supply enable time | $V_{CC} = 5 \text{ V}$ | 100 | μs |

(1) All typical values are at $V_{CC} = 3.3 \text{ V}$ or $V_{CC} = 5 \text{ V}$ and $T_A = 25^\circ\text{C}$.

PARAMETER MEASUREMENT INFORMATION

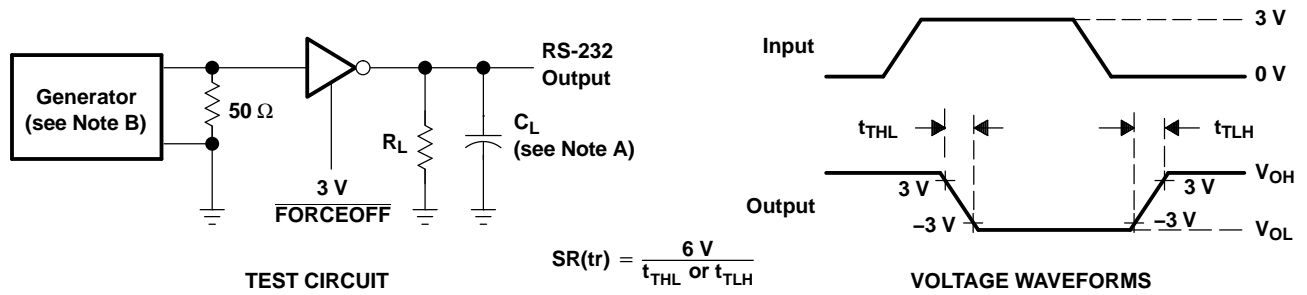

NOTES: A. C_L includes probe and jig capacitance.
B. The pulse generator has the following characteristics: PRR = 250 kbit/s

Figure 1. Driver Slew Rate

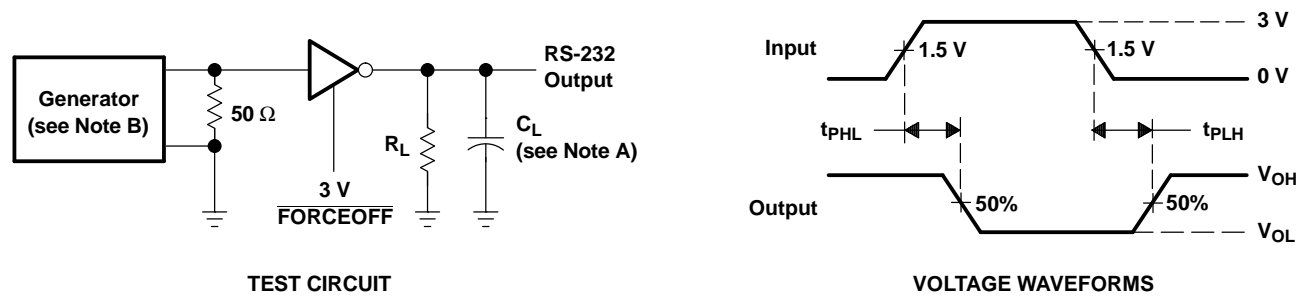

NOTES: A. C_L includes probe and jig capacitance.
B. The pulse generator has the following characteristics: PRR = 250 kbit/s, $Z_O = 50\ \Omega$, 50% duty cycle, $t_r \leq 10\text{ ns}$, $t_f \leq 10\text{ ns}$.

Figure 2. Driver Pulse Skew

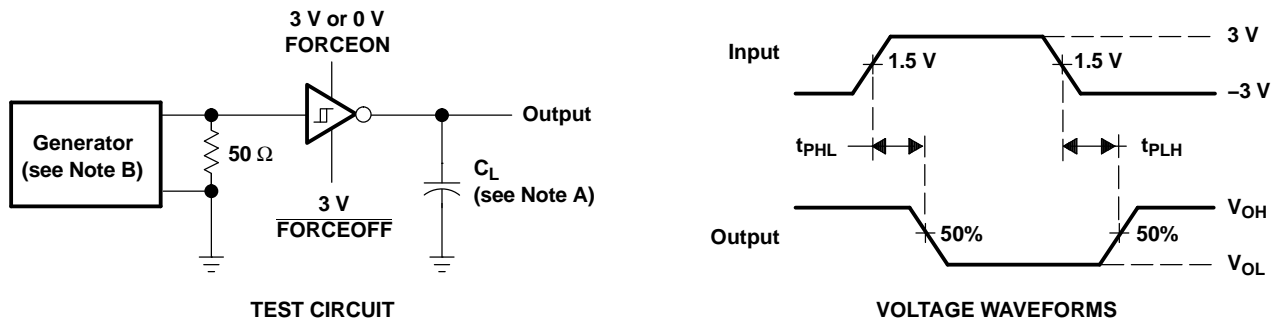

NOTES: A. C_L includes probe and jig capacitance.
B. The pulse generator has the following characteristics: $Z_O = 50\ \Omega$, 50% duty cycle, $t_r \leq 10\text{ ns}$, $t_f \leq 10\text{ ns}$.

Figure 3. Receiver Propagation Delay Times

PARAMETER MEASUREMENT INFORMATION

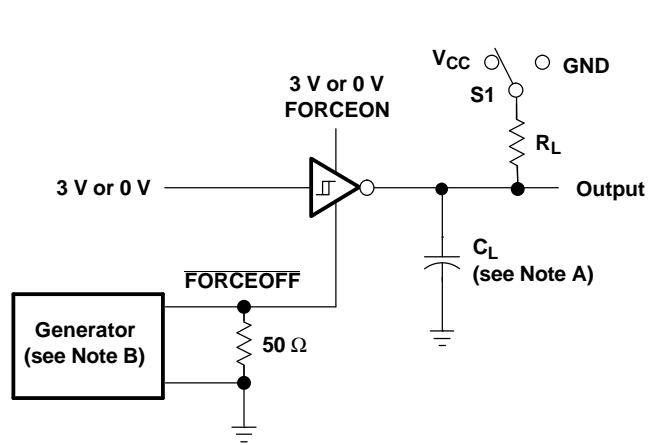

TEST CIRCUIT

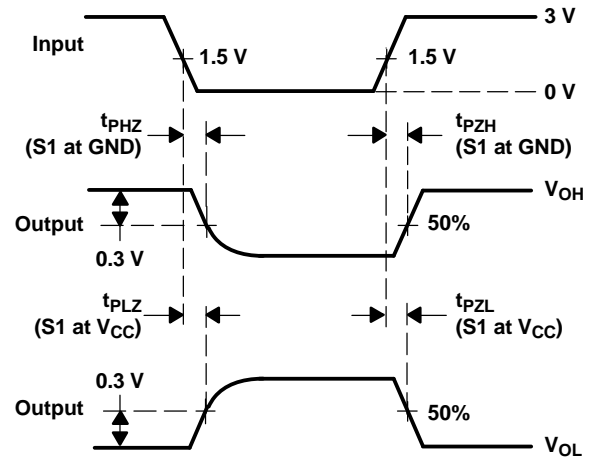

VOLTAGE WAVEFORMS

- NOTES: A. C_L includes probe and jig capacitance.
B. The pulse generator has the following characteristics: Z_O = 50 Ω, 50% duty cycle, t_r ≤ 10 ns, t_f ≤ 10 ns.
C. t_{PLZ} and t_{PHZ} are the same as t_{dis}.
D. t_{PZL} and t_{PZH} are the same as t_{en}.

Figure 4. Receiver Enable and Disable Times

PARAMETER MEASUREMENT INFORMATION

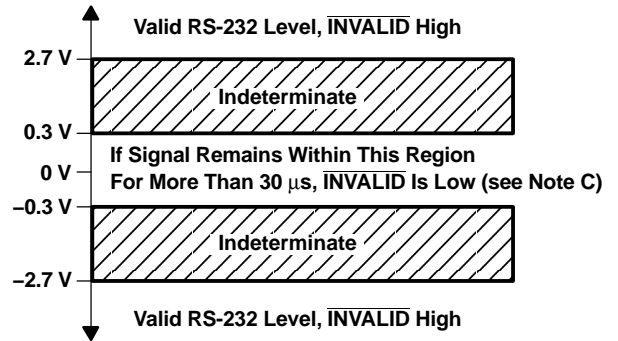
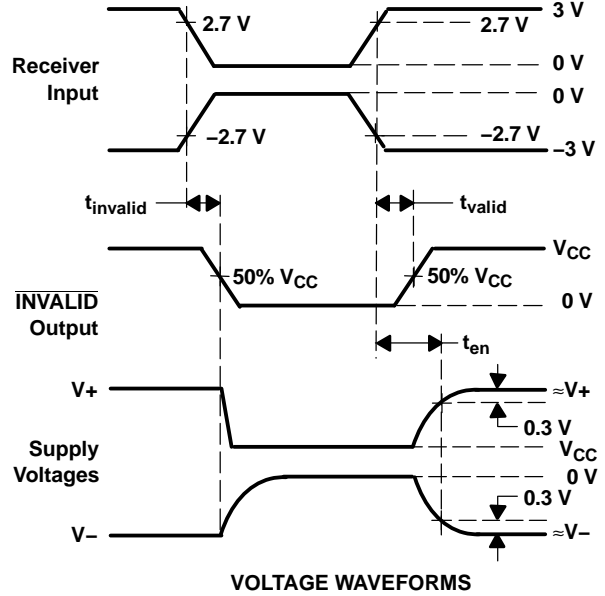
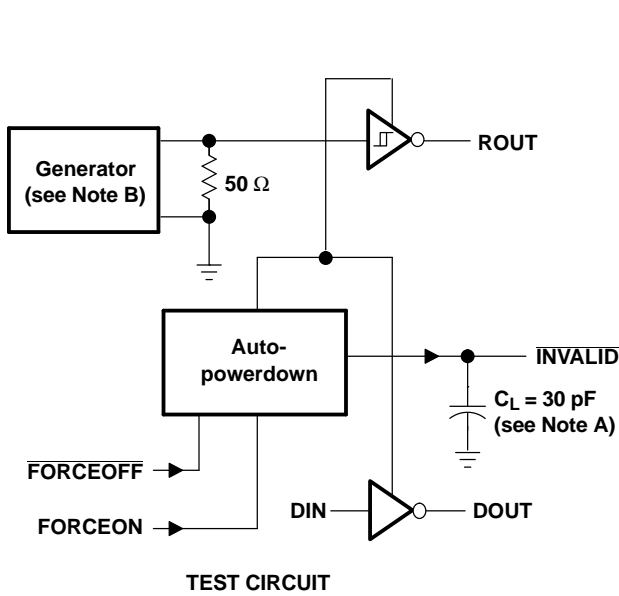

- NOTES: A. C_L includes probe and jig capacitance.
B. The pulse generator has the following characteristics: PRR = 5 kbit/s, $Z_O = 50 \Omega$, 50% duty cycle, $t_r \leq 10 \text{ ns}$, $t_f \leq 10 \text{ ns}$.
C. Auto-powerdown disables drivers and reduces supply current to 1 μA .

Figure 5. $\overline{\text{INVALID}}$ Propagation Delay Times and Supply Enabling Time

APPLICATION INFORMATION

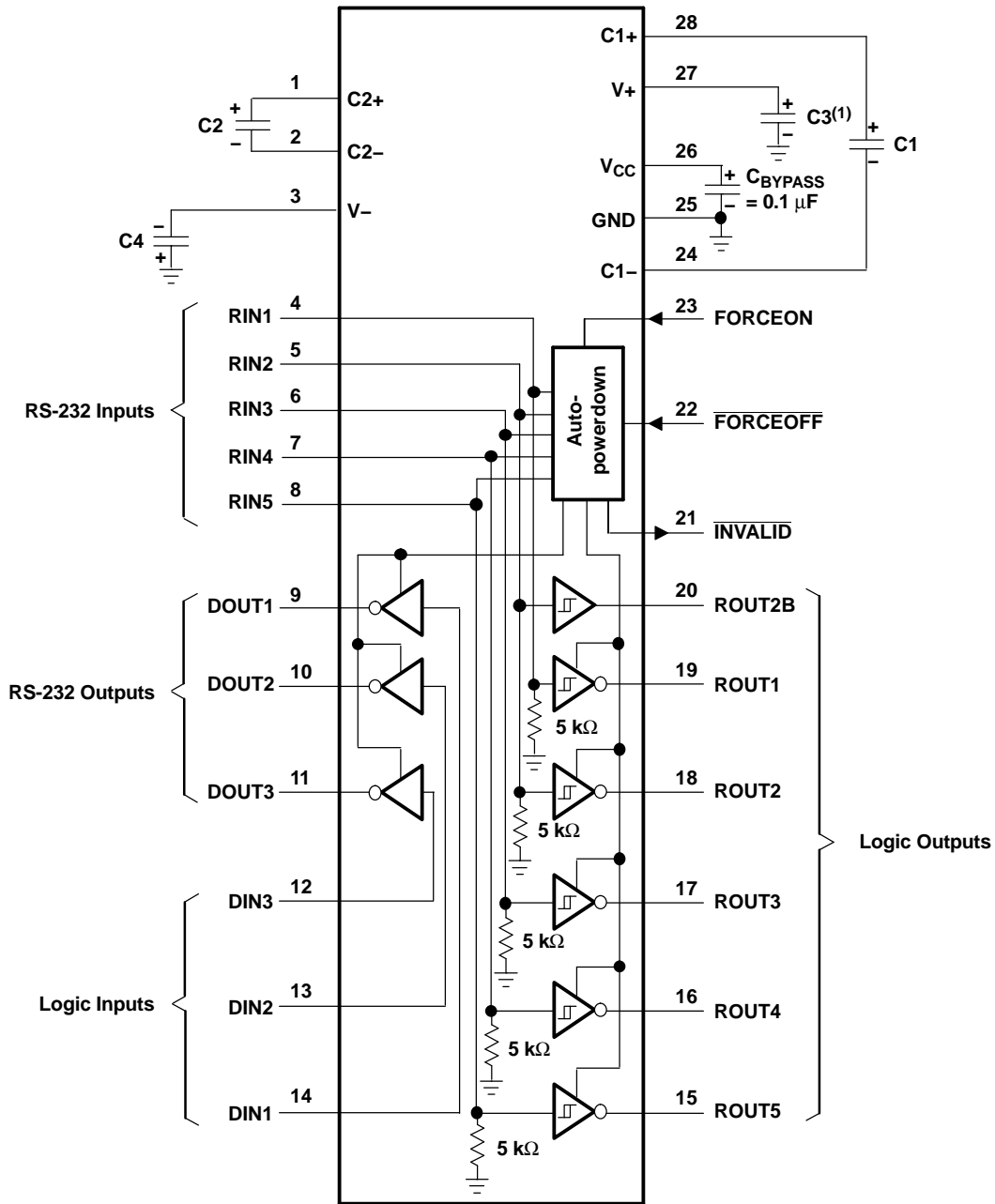

(1) C3 can be connected to V_{CC} or GND.

- NOTES: A. Resistor values shown are nominal.
 B. Nonpolarized ceramic capacitors are acceptable. If polarized tantalum or electrolytic capacitors are used, they should be connected as shown.

V_{CC} vs CAPACITOR VALUES

| V_{CC} | C1 | C2, C3, and C4 |
|-------------------|---------------|----------------|
| 3.3 V \pm 0.3 V | 0.1 μ F | 0.1 μ F |
| 5 V \pm 0.5 V | 0.047 μ F | 0.33 μ F |
| 3 V to 5.5 V | 0.1 μ F | 0.47 μ F |

Figure 6. Typical Operating Circuit and Capacitor Values

TAPE AND REEL INFORMATION



QUADRANT ASSIGNMENTS FOR PIN 1 ORIENTATION IN TAPE



*All dimensions are nominal

| Device | Package Type | Package Drawing | Pins | SPQ | Reel Diameter (mm) | Reel Width W1 (mm) | A0 (mm) | B0 (mm) | K0 (mm) | P1 (mm) | W (mm) | Pin1 Quadrant |
|---------------|--------------|-----------------|------|------|--------------------|--------------------|---------|---------|---------|---------|--------|---------------|
| MAX3243MDBREP | SSOP | DB | 28 | 2000 | 330.0 | 16.4 | 8.2 | 10.5 | 2.5 | 12.0 | 16.0 | Q1 |

TAPE AND REEL BOX DIMENSIONS



*All dimensions are nominal

| Device | Package Type | Package Drawing | Pins | SPQ | Length (mm) | Width (mm) | Height (mm) |
|---------------|--------------|-----------------|------|------|-------------|------------|-------------|
| MAX3243MDBREP | SSOP | DB | 28 | 2000 | 367.0 | 367.0 | 38.0 |

MECHANICAL DATA

PW (R-PDSO-G28)

PLASTIC SMALL OUTLINE

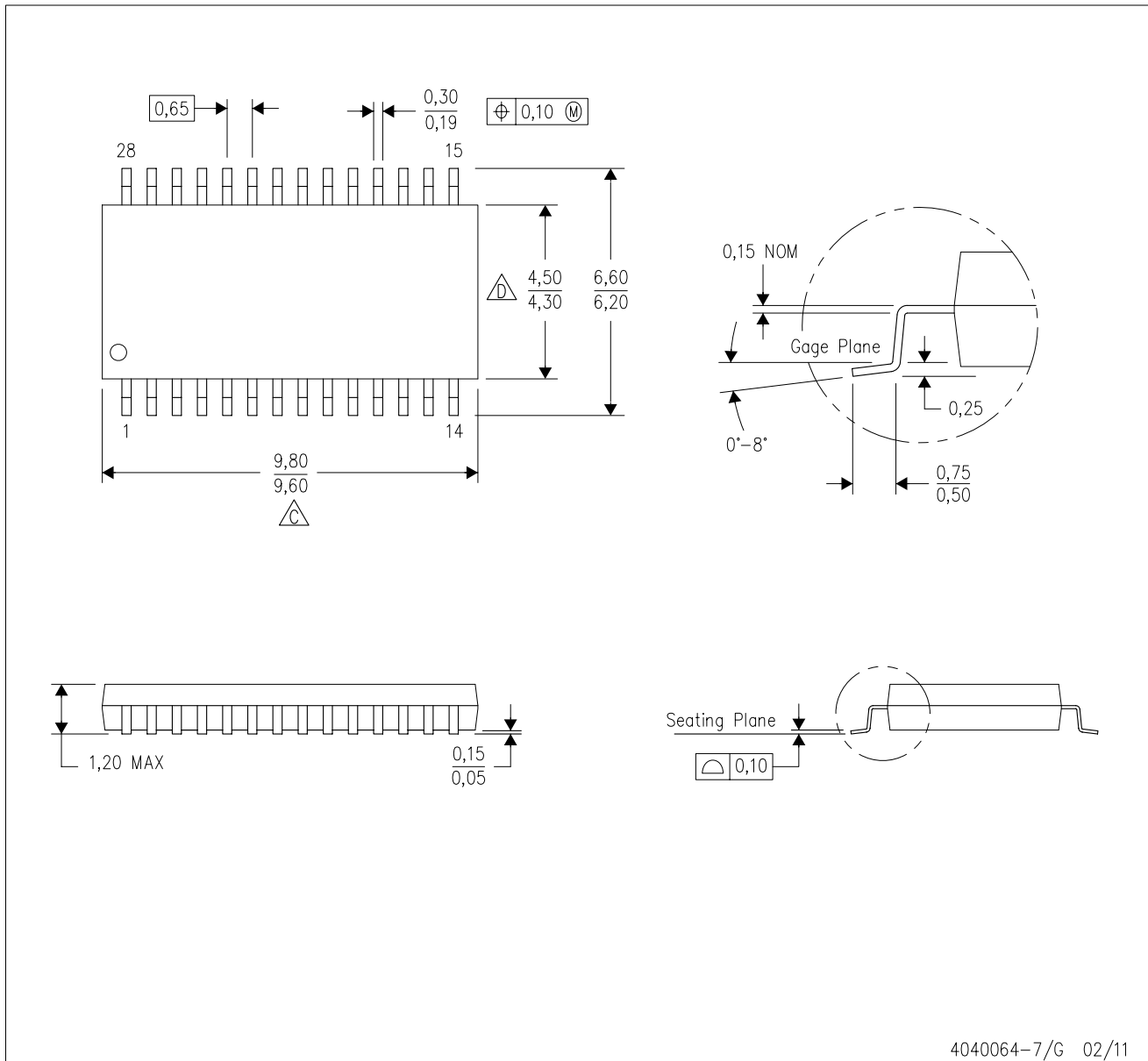

4040064-7/G 02/11

- NOTES:
- A. All linear dimensions are in millimeters. Dimensioning and tolerancing per ASME Y14.5M-1994.
 - B. This drawing is subject to change without notice.
 - C. Body length does not include mold flash, protrusions, or gate burrs. Mold flash, protrusions, or gate burrs shall not exceed 0,15 each side.
 - D. Body width does not include interlead flash. Interlead flash shall not exceed 0,25 each side.
 - E. Falls within JEDEC MO-153

PW (R-PDSO-G28)

PLASTIC SMALL OUTLINE

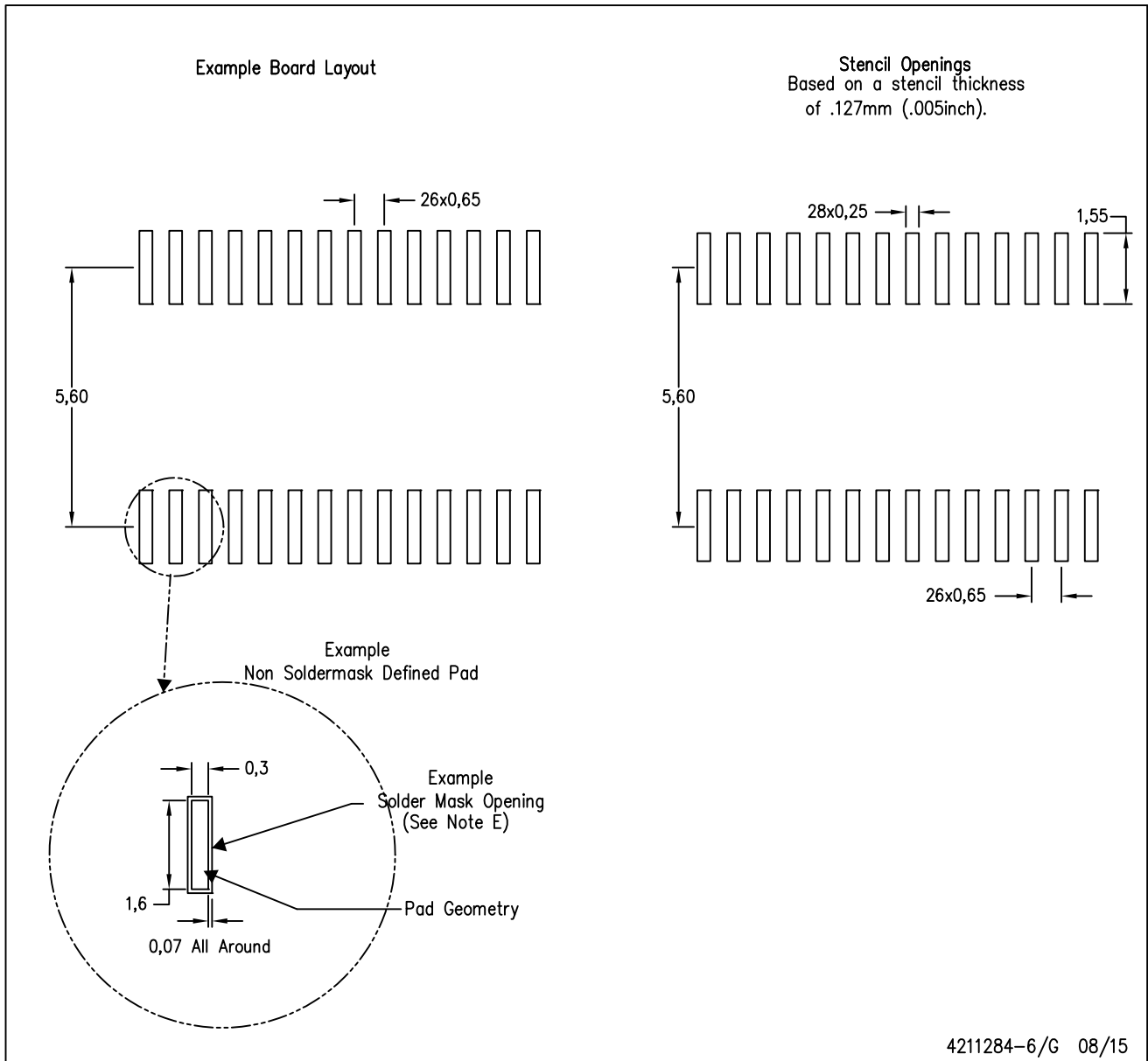

- NOTES:
- All linear dimensions are in millimeters.
 - This drawing is subject to change without notice.
 - Publication IPC-7351 is recommended for alternate design.
 - Laser cutting apertures with trapezoidal walls and also rounding corners will offer better paste release. Customers should contact their board assembly site for stencil design recommendations. Refer to IPC-7525 for other stencil recommendations.
 - Customers should contact their board fabrication site for solder mask tolerances between and around signal pads.

DB (R-PDSO-G**)

PLASTIC SMALL-OUTLINE

28 PINS SHOWN



- NOTES: A. All linear dimensions are in millimeters.
 B. This drawing is subject to change without notice.
 C. Body dimensions do not include mold flash or protrusion not to exceed 0,15.
 D. Falls within JEDEC MO-150

IMPORTANT NOTICE

Texas Instruments Incorporated and its subsidiaries (TI) reserve the right to make corrections, enhancements, improvements and other changes to its semiconductor products and services per JESD46, latest issue, and to discontinue any product or service per JESD48, latest issue. Buyers should obtain the latest relevant information before placing orders and should verify that such information is current and complete. All semiconductor products (also referred to herein as "components") are sold subject to TI's terms and conditions of sale supplied at the time of order acknowledgment.

TI warrants performance of its components to the specifications applicable at the time of sale, in accordance with the warranty in TI's terms and conditions of sale of semiconductor products. Testing and other quality control techniques are used to the extent TI deems necessary to support this warranty. Except where mandated by applicable law, testing of all parameters of each component is not necessarily performed.

TI assumes no liability for applications assistance or the design of Buyers' products. Buyers are responsible for their products and applications using TI components. To minimize the risks associated with Buyers' products and applications, Buyers should provide adequate design and operating safeguards.

TI does not warrant or represent that any license, either express or implied, is granted under any patent right, copyright, mask work right, or other intellectual property right relating to any combination, machine, or process in which TI components or services are used. Information published by TI regarding third-party products or services does not constitute a license to use such products or services or a warranty or endorsement thereof. Use of such information may require a license from a third party under the patents or other intellectual property of the third party, or a license from TI under the patents or other intellectual property of TI.

Reproduction of significant portions of TI information in TI data books or data sheets is permissible only if reproduction is without alteration and is accompanied by all associated warranties, conditions, limitations, and notices. TI is not responsible or liable for such altered documentation. Information of third parties may be subject to additional restrictions.

Resale of TI components or services with statements different from or beyond the parameters stated by TI for that component or service voids all express and any implied warranties for the associated TI component or service and is an unfair and deceptive business practice. TI is not responsible or liable for any such statements.

Buyer acknowledges and agrees that it is solely responsible for compliance with all legal, regulatory and safety-related requirements concerning its products, and any use of TI components in its applications, notwithstanding any applications-related information or support that may be provided by TI. Buyer represents and agrees that it has all the necessary expertise to create and implement safeguards which anticipate dangerous consequences of failures, monitor failures and their consequences, lessen the likelihood of failures that might cause harm and take appropriate remedial actions. Buyer will fully indemnify TI and its representatives against any damages arising out of the use of any TI components in safety-critical applications.

In some cases, TI components may be promoted specifically to facilitate safety-related applications. With such components, TI's goal is to help enable customers to design and create their own end-product solutions that meet applicable functional safety standards and requirements. Nonetheless, such components are subject to these terms.

No TI components are authorized for use in FDA Class III (or similar life-critical medical equipment) unless authorized officers of the parties have executed a special agreement specifically governing such use.

Only those TI components which TI has specifically designated as military grade or "enhanced plastic" are designed and intended for use in military/aerospace applications or environments. Buyer acknowledges and agrees that any military or aerospace use of TI components which have **not** been so designated is solely at the Buyer's risk, and that Buyer is solely responsible for compliance with all legal and regulatory requirements in connection with such use.

TI has specifically designated certain components as meeting ISO/TS16949 requirements, mainly for automotive use. In any case of use of non-designated products, TI will not be responsible for any failure to meet ISO/TS16949.

Products

| | |
|------------------------------|--------------------------------------------------------------------------------------|
| Audio | www.ti.com/audio |
| Amplifiers | amplifier.ti.com |
| Data Converters | dataconverter.ti.com |
| DLP® Products | www.dlp.com |
| DSP | dsp.ti.com |
| Clocks and Timers | www.ti.com/clocks |
| Interface | interface.ti.com |
| Logic | logic.ti.com |
| Power Mgmt | power.ti.com |
| Microcontrollers | microcontroller.ti.com |
| RFID | www.ti-rfid.com |
| OMAP Applications Processors | www.ti.com/omap |
| Wireless Connectivity | www.ti.com/wirelessconnectivity |

Applications

| | |
|-------------------------------|------------------------------------------------------------------------------------------|
| Automotive and Transportation | www.ti.com/automotive |
| Communications and Telecom | www.ti.com/communications |
| Computers and Peripherals | www.ti.com/computers |
| Consumer Electronics | www.ti.com/consumer-apps |
| Energy and Lighting | www.ti.com/energy |
| Industrial | www.ti.com/industrial |
| Medical | www.ti.com/medical |
| Security | www.ti.com/security |
| Space, Avionics and Defense | www.ti.com/space-avionics-defense |
| Video and Imaging | www.ti.com/video |

TI E2E Community

e2e.ti.com