



The following document contains information on Cypress products. Although the document is marked with the name “Spansion” and “Fujitsu”, the company that originally developed the specification, Cypress will continue to offer these products to new and existing customers.

Continuity of Specifications

There is no change to this document as a result of offering the device as a Cypress product. Any changes that have been made are the result of normal document improvements and are noted in the document history page, where supported. Future revisions will occur when appropriate, and changes will be noted in a document history page.

Continuity of Ordering Part Numbers

Cypress continues to support existing part numbers. To order these products, please use only the Ordering Part Numbers listed in this document.

For More Information

Please contact your local sales office for additional information about Cypress products and solutions.

About Cypress

Cypress (NASDAQ: CY) delivers high-performance, high-quality solutions at the heart of today’s most advanced embedded systems, from automotive, industrial and networking platforms to highly interactive consumer and mobile devices. With a broad, differentiated product portfolio that includes NOR flash memories, F-RAM™ and SRAM, Traveo™ microcontrollers, the industry’s only PSoC® programmable system-on-chip solutions, analog and PMIC Power Management ICs, CapSense® capacitive touch-sensing controllers, and Wireless BLE Bluetooth® Low-Energy and USB connectivity solutions, Cypress is committed to providing its customers worldwide with consistent innovation, best-in-class support and exceptional system value.

ASSP

BIPOLAR

Power Supply Monitor with Watch-Dog Timer

MB3773

■ DESCRIPTION

MB3773 generates the reset signal to protect an arbitrary system when the power-supply voltage momentarily is intercepted or decreased. It is IC for the power-supply voltage watch and "Power on reset" is generated at the normal return of the power supply. MB3773 sends the microprocessor the reset signal when decreasing more than the voltage, which the power supply of the system specified, and the computer data is protected from an accidental deletion.

In addition, the watch-dog timer for the operation diagnosis of the system is built into, and various microprocessor systems can provide the fail-safe function. If MB3773 does not receive the clock pulse from the processor for a specified period, MB3773 generates the reset signal.

■ FEATURES

- Precision voltage detection ($V_s = 4.2 \text{ V} \pm 2.5 \%$)
- Detection threshold voltage has hysteresis function
- Low voltage output for reset signal ($V_{CC} = 0.8 \text{ V Typ}$)
- Precision reference voltage output ($V_R = 1.245 \text{ V} \pm 1.5\%$)
- With built-in watch-dog timer of edge trigger input.
- External parts are few.(1 piece in capacity)
- The reset signal outputs the positive and negative both theories reason.
- One type of package (SOP-8pin : 1 type)

■ APPLICATION

- Industrial Equipment
- Arcade Amusement etc.

■ PIN ASSIGNMENT

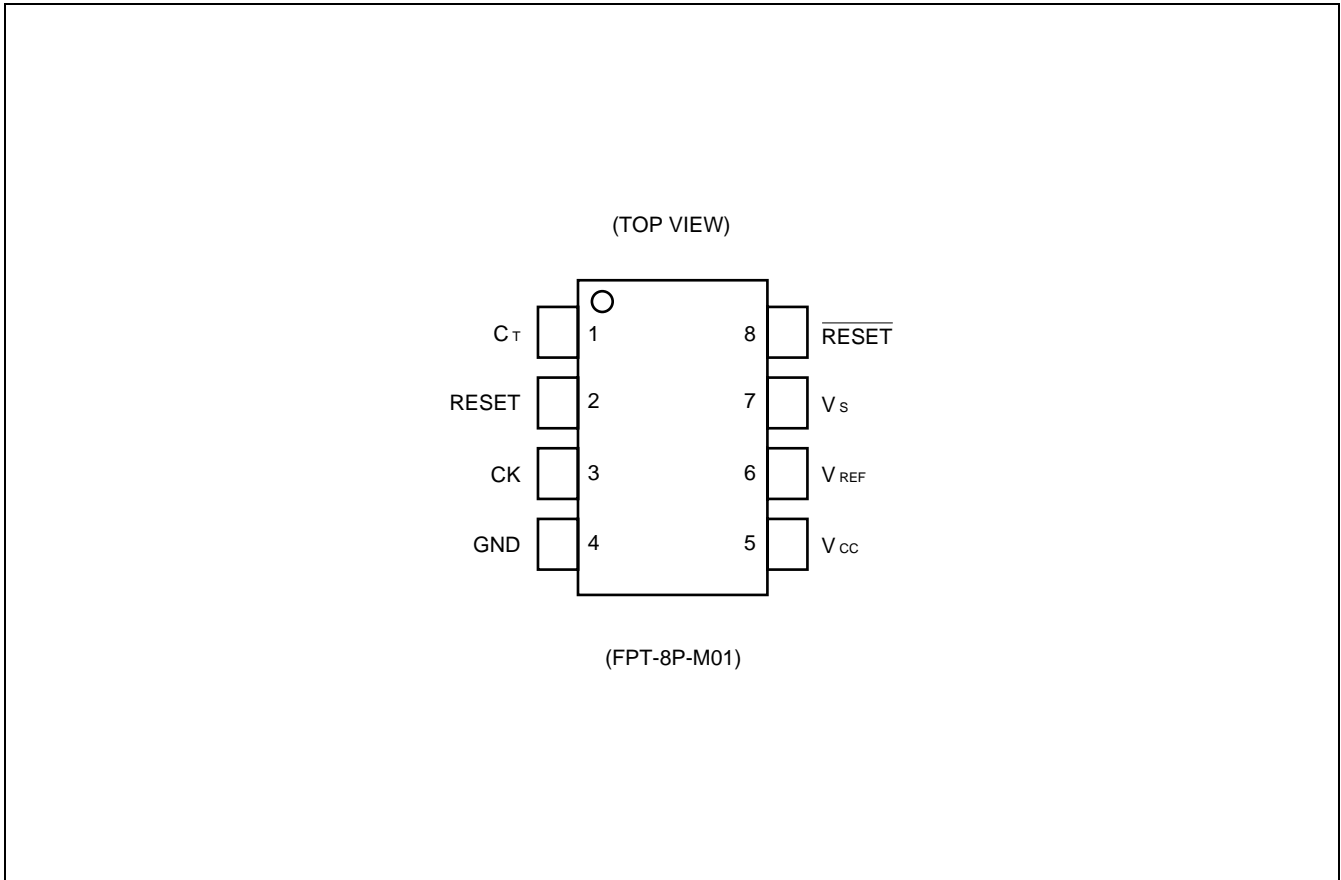

■ BLOCK DIAGRAM

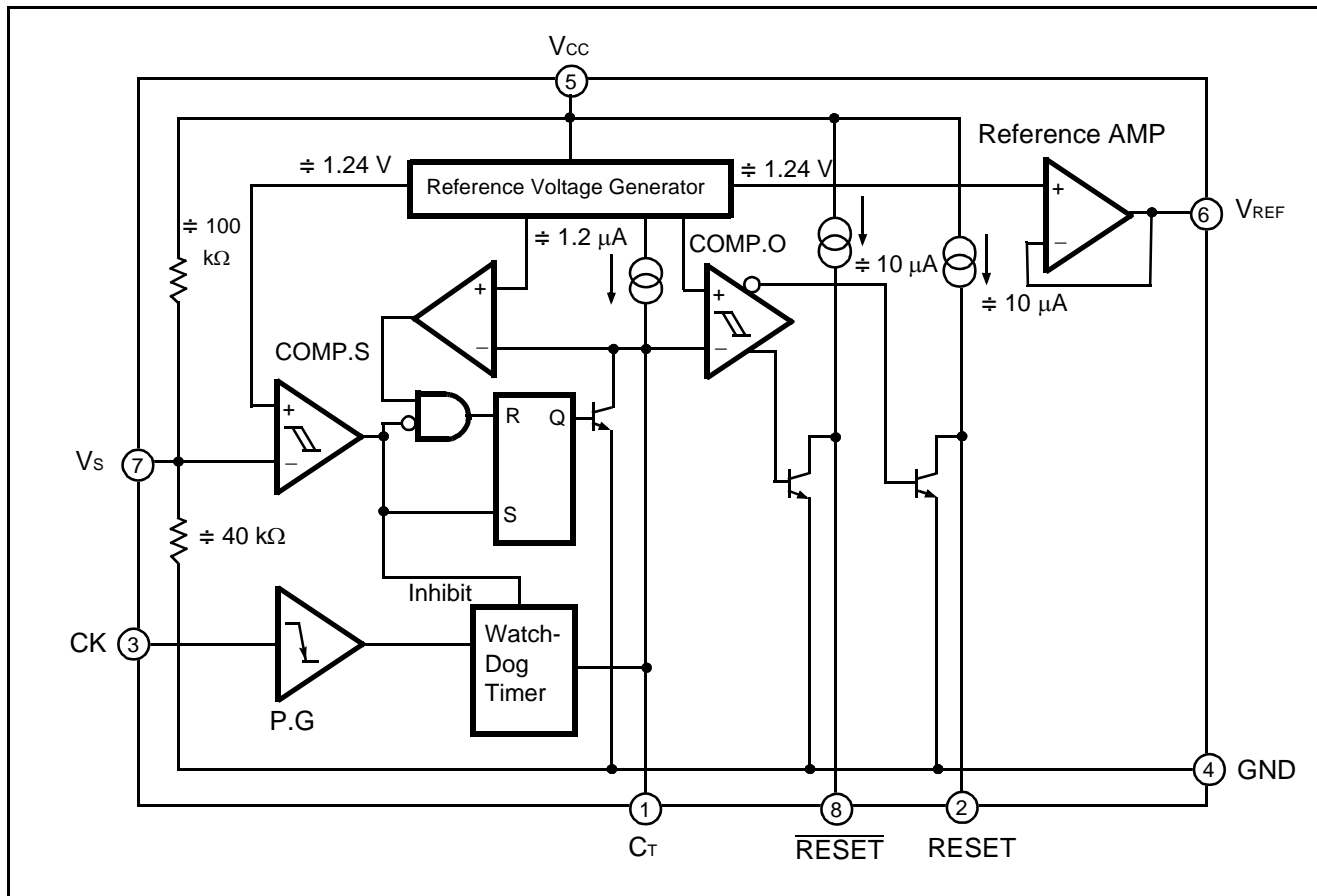

■ FUNCTIONAL DESCRIPTIONS

Comp.S is comparator including hysteresis. it compare the reference voltage and the voltage of Vs, so that when the voltage of Vs terminal falls below approximately 1.23 V, reset signal outputs.

Instantaneous breaks or drops in the power can be detected as abnormal conditions by the MB3773 within a 2 μ s interval.

However because momentary breaks or drops of this duration do not cause problems in actual systems in some cases, a delayed trigger function can be created by connecting capacitors to the Vs terminal.

Comp.O is comparator for turning on/off the output and, compare the voltage of the C_T terminal and the threshold voltage. Because the RESET/ $\overline{\text{RESET}}$ outputs have built-in pull-up circuit, there is no need to connect to external pull-up resistor when connected to a high impedance load such as CMOS logic IC.

(It corresponds to 500 k Ω at V_{cc} = 5 V.) when the voltage of the CK terminal changes from the "high" level into the "Low" level, pulse generator is sent to the watch-dog timer by generating the pulse momentarily at the time of drop from the threshold level.

When power-supply voltages fall more than detecting voltages, the watch-dog timer becomes an interdiction.

The Reference amplifier is an op-amp to output the reference voltage.

If the comparator is put up outside, two or more power-supply voltage monitor and overvoltage monitor can be done.

If it uses a comparator of the open-collector output, and the output of the comparator is connected with the Vs terminal of MB3773 without the pull-up resistor, it is possible to voltage monitor with reset-hold time.

• MB3773 Basic Operation

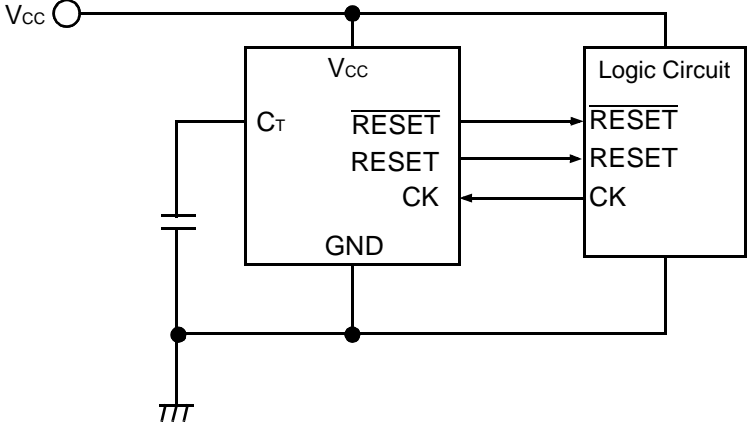

$T_{PR} \text{ (ms)} \doteq 1000 \cdot C_T \text{ (\mu F)}$
 $T_{WD} \text{ (ms)} \doteq 100 \cdot C_T \text{ (\mu F)}$
 $T_{WR} \text{ (ms)} \doteq 20 \cdot C_T \text{ (\mu F)}$

Example : $C_T = 0.1 \mu\text{F}$
 $T_{RR} \text{ (ms)} \doteq 100 \text{ (ms)}$
 $T_{WD} \text{ (ms)} \doteq 10 \text{ (ms)}$
 $T_{WR} \text{ (ms)} \doteq 2 \text{ (ms)}$

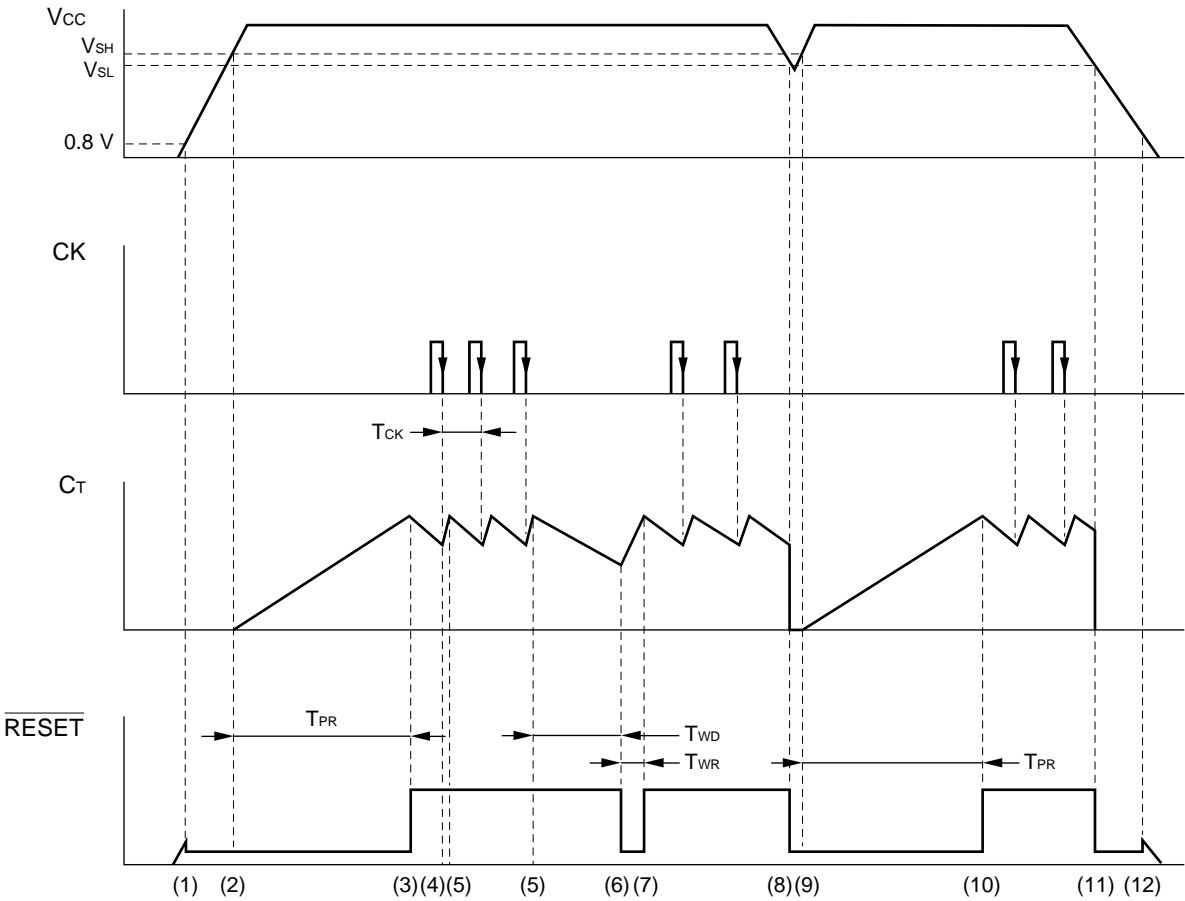

■ OPERATION SEQUENCE

- (1) When V_{CC} rises to about 0.8 V, $\overline{\text{RESET}}$ goes “Low” and RESET goes “High”.
The pull-up current of approximately 1 μA ($V_{CC} = 0.8 \text{ V}$) is output from RESET.
- (2) When V_{CC} rises to V_{SH} ($\approx 4.3\text{V}$), the charge with C_T starts.
At this time, the output is being reset.
- (3) When C_T begins charging, $\overline{\text{RESET}}$ goes “High” and RESET goes “Low”.
After T_{PR} reset of the output is released.
Reset hold time: $T_{PR} (\text{ms}) \approx 1000 \times C_T (\mu\text{F})$
After releasing reset, the discharge of C_T starts, and watch-dog timer operation starts.
 T_{PR} is not influenced by the CK input.
- (4) C changes from the discharge into the charge if the clock (Negative edge) is input to the CK terminal while discharging C_T .
- (5) C changes from the charge into the discharge when the voltage of C_T reaches a constant threshold ($\approx 1.4 \text{ V}$).
(4) and (5) are repeated while a normal clock is input by the logic system.
- (6) When the clock is cut off, gets, and the voltage of C_T falls on threshold ($\approx 0.4 \text{ V}$) of reset on, $\overline{\text{RESET}}$ goes “Low” and RESET goes “High”.
Discharge time of C_T until reset is output: T_{WD} is watch-dog timer monitoring time.
 $T_{WD} (\text{ms}) \approx 100 \times C_T (\mu\text{F})$
Because the charging time of C_T is added at accurate time from stop of the clock and getting to the output of reset of the clock, T_{WD} becomes maximum $T_{WD} + T_{WR}$ by minimum T_{WD} .
- (7) Reset time in operating watch-dog timer: T_{WR} is charging time where the voltage of C_T goes up to off threshold ($\approx 1.4 \text{ V}$) for reset.
 $T_{WR} (\text{ms}) \approx 20 \times C_T (\mu\text{F})$
Reset of the output is released after C_T reaches an off threshold for reset, and C_T starts the discharge, after that if the clock is normally input, operation repeats (4) and (5), when the clock is cut off, operation repeats (6) and (7).
- (8) When V_{CC} falls on V_{SL} ($\approx 4.2 \text{ V}$), reset is output. C_T is rapidly discharged of at the same time.
- (9) When V_{CC} goes up to V_{SH} , the charge with C_T is started.
When V_{CC} is momentarily low,
After falling V_{SL} or less V_{CC} , the time to going up is the standard value of the V_{CC} input pulse width in V_{SH} or more.
After the charge of C_T is discharged, the charge is started if it is T_{PI} or more.
- (10) Reset of the output is released after T_{PR} , after V_{CC} becomes V_{SH} or more, and the watch-dog timer starts.
After that, when V_{CC} becomes V_{SL} or less, (8) to (10) is repeated.
- (11) While power supply is off, when V_{CC} becomes V_{SL} or less, reset is output.
- (12) The reset output is maintained until V_{CC} becomes 0.8 V when V_{CC} falls on 0 V.

■ ABSOLUTE MAXIMUM RATINGS

Parameter	Symbol	Rating		Unit
		Min	Max	
Supply voltage	V _{CC}	- 0.3	+ 18	V
Input voltage	V _S	- 0.3	V _{CC} + 0.3 (≤ +18)	V
	V _{CK}	- 0.3	+ 18	V
$\overline{\text{RESET}}$, RESET Supply voltage	V _{OH}	- 0.3	V _{CC} + 0.3 (≤ +18)	V
Power dissipation (T _a ≤ +85 °C)	P _D	—	200	mW
Storage temperature	T _{STG}	- 55	+ 125	°C

WARNING: Semiconductor devices can be permanently damaged by application of stress (voltage, current, temperature, etc.) in excess of absolute maximum ratings. Do not exceed these ratings.

■ RECOMMENDED OPERATING CONDITIONS

Parameter	Symbol	Value		Unit
		Min	Max	
Supply voltage	V _{CC}	+ 3.5	+ 16	V
RESET, $\overline{\text{RESET}}$ sink current	I _{OL}	0	20	mA
V _{REF} output current	I _{OUT}	- 200	+ 5	μA
Watch clock setting time	t _{WD}	0.1	1000	ms
CK Rising/falling time	t _{FC} , t _{RC}	—	100	μs
Terminal capacitance	C _T	0.001	10	μF
Operating ambient temperature	T _a	- 40	+ 85	°C

WARNING: The recommended operating conditions are required in order to ensure the normal operation of the semiconductor device. All of the device's electrical characteristics are warranted when the device is operated within these ranges.



Always use semiconductor devices within their recommended operating condition ranges. Operation outside these ranges may adversely affect reliability and could result in device failure.

No warranty is made with respect to uses, operating conditions, or combinations not represented on the data sheet. Users considering application outside the listed conditions are advised to contact their representatives beforehand.

■ ELECTORICAL CHARACTERISTICS

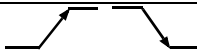

(1) DC Characteristics

(V_{CC} = 5 V, T_a = +25 °C)

Parameter	Symbol	Condition	Value			Unit
			Min	Typ	Max	
Supply current	I _{CC}	Watch-dog timer operating	—	600	900	μA
Detection voltage	V _{SL}	V _{CC} 	4.10	4.20	4.30	V
		T _a = -40 °C to +85 °C	4.05	4.20	4.35	
	V _{SH}	V _{CC} 	4.20	4.30	4.40	
		T _a = -40 °C to +85 °C	4.15	4.30	4.45	
Hysteresis width	V _{HYS}	V _{CC} 	50	100	150	mV
Reference voltage	V _{REF}	—	1.227	1.245	1.263	V
		T _a = -40 °C to +85 °C	1.215	1.245	1.275	
Reference voltage change rate	ΔV _{REF1}	V _{CC} = 3.5 V to 16 V	—	3	10	mV
Reference voltage output loading change rate	ΔV _{REF2}	I _{OUT} = -200 μA to +5 μA	-5	—	+5	mV
CK threshold voltage	V _{TH}	T _a = -40 °C to +85 °C	0.8	1.25	2.0	V
CK input current	I _{IH}	V _{CK} = 5.0 V	—	0	1.0	μA
	I _{IL}	V _{CK} = 0.0 V	-1.0	-0.1	—	
C _T discharge current	I _{CTD}	Watch-dog timer operating V _{CT} = 1.0 V	7	10	14	μA
High level output voltage	V _{OH1}	V _S open, I _{RESET} = -5 μA	4.5	4.9	—	V
	V _{OH2}	V _S = 0 V, I _{RESET} = -5 μA	4.5	4.9	—	
Output saturation voltage	V _{OL1}	V _S = 0 V, I _{RESET} = 3 mA	—	0.2	0.4	V
	V _{OL2}	V _S = 0 V, I _{RESET} = 10 mA	—	0.3	0.5	
	V _{OL3}	V _S open, I _{RESET} = 3 mA	—	0.2	0.4	
	V _{OL4}	V _S open, I _{RESET} = 10 mA	—	0.3	0.5	
Output sink current	I _{OL1}	V _S = 0 V, V _{RESET} = 1.0 V	20	60	—	mA
	I _{OL2}	V _S open, V _{RESET} = 1.0 V	20	60	—	
C _T charge current	I _{CTU}	Power on reset operating V _{CT} = 1.0 V	0.5	1.2	2.5	μA
Min supply voltage for $\overline{\text{RESET}}$	V _{CC1}	V _{RESET} = 0.4 V, I _{RESET} = 0.2 mA	—	0.8	1.2	V
Min supply voltage for RESET	V _{CC2}	V _{RESET} = V _{CC} - 0.1 V, R _L (between pin 2 and GND) = 1 MΩ	—	0.8	1.2	V

(2)AC Characteristics

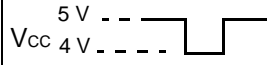
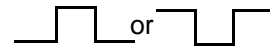
(V_{CC} = 5 V, T_a = + 25 °C)

Parameter	Symbol	Condition	Value			Unit
			Min	Typ	Max	
V _{CC} input pulse width	T _{PI}	V _{CC} 	8.0	—	—	μs
CK input pulse width	T _{CKW}	CK 	3.0	—	—	μs
CK input frequency	T _{CK}	—	20	—	—	μs
Watch-dog timer watching time	T _{WD}	C _T = 0.1 μF	5	10	15	ms
Watch-dog timer reset time	T _{WR}	C _T = 0.1 μF	1	2	3	ms
Rising reset hold time	T _{PR}	C _T = 0.1 μF, V _{CC} 	50	100	150	ms
Output propagation delay time from V _{CC}	T _{PD1}	RESET, R _L = 2.2 kΩ, C _L = 100 pF	—	2	10	μs
	T _{PD2}	RESET, R _L = 2.2 kΩ, C _L = 100 pF	—	3	10	
Output rising time*	t _R	R _L = 2.2 kΩ, C _L = 100 pF	—	1.0	1.5	μs
Output falling time*	t _F	R _L = 2.2 kΩ, C _L = 100 pF	—	0.1	0.5	

* : Output rising/falling time are measured at 10 % to 90 % of voltage.

TYPICAL CHARACTERISTIC CURVES

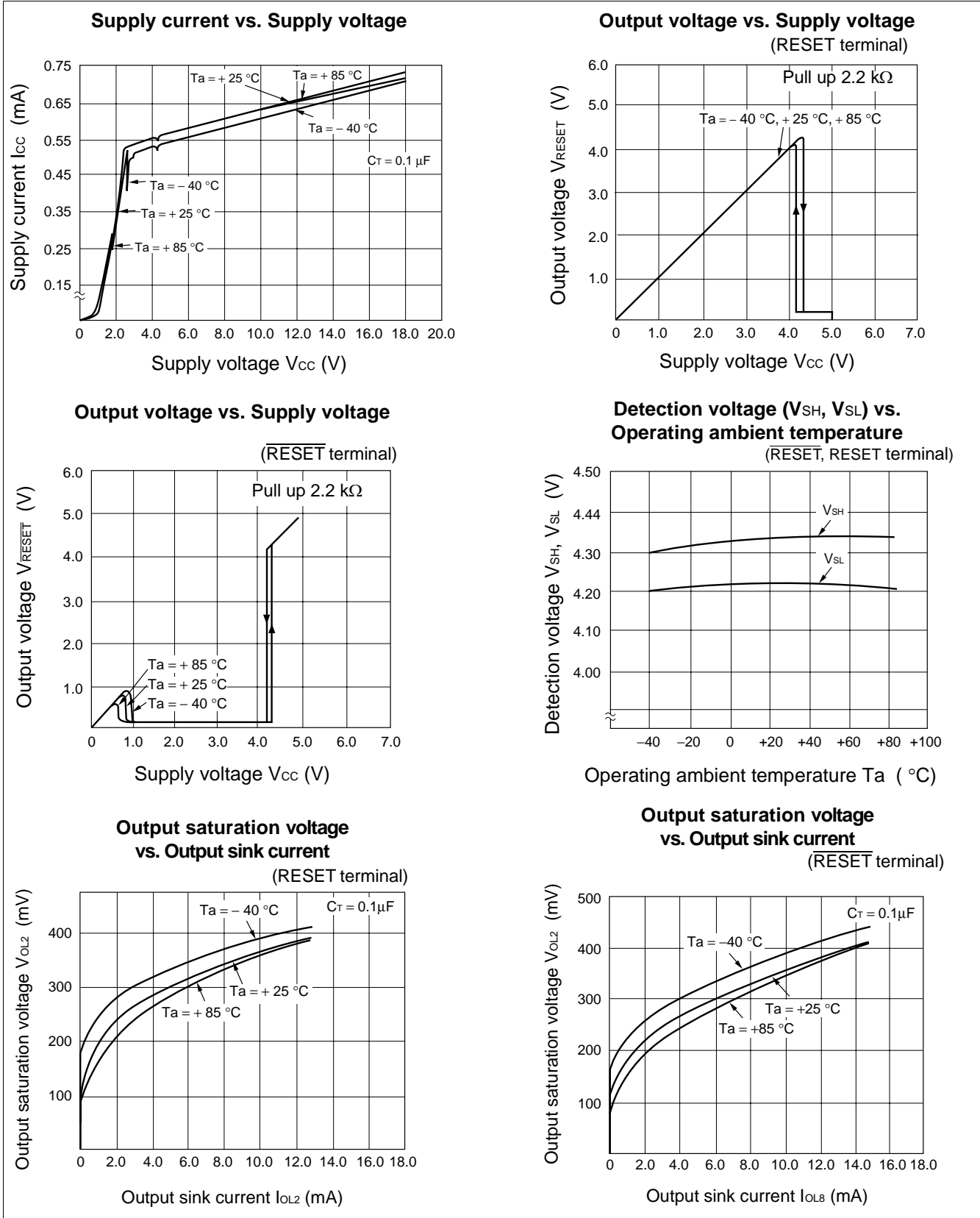

(Continued)

High level output voltage vs. High level output current

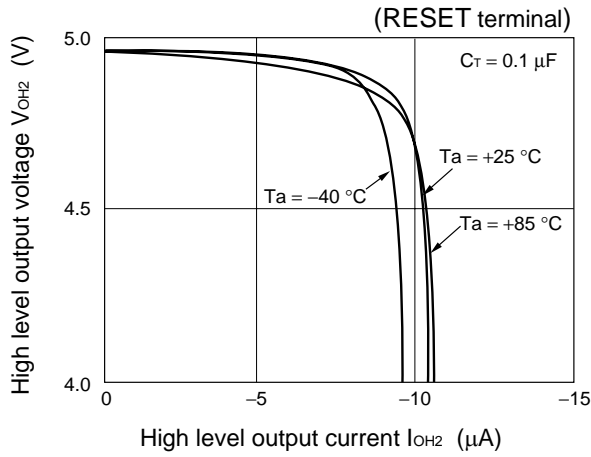

High level output voltage vs. High level output current

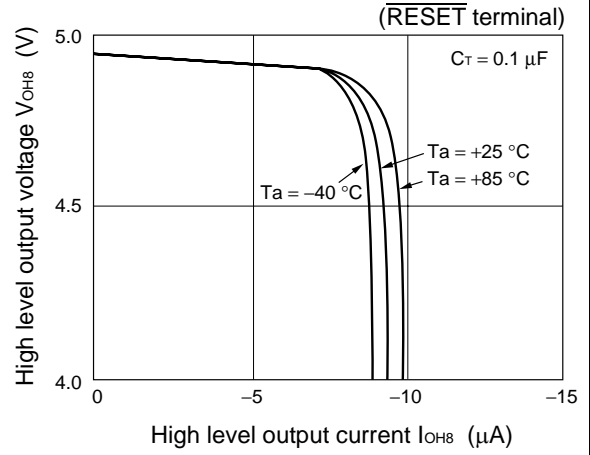

Reference voltage vs. Supply voltage

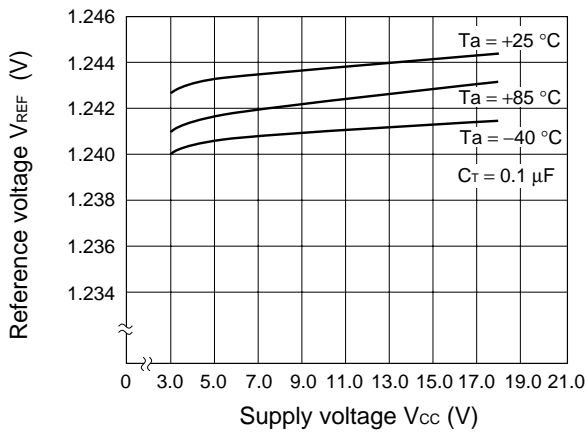

Reference voltage vs. Reference current

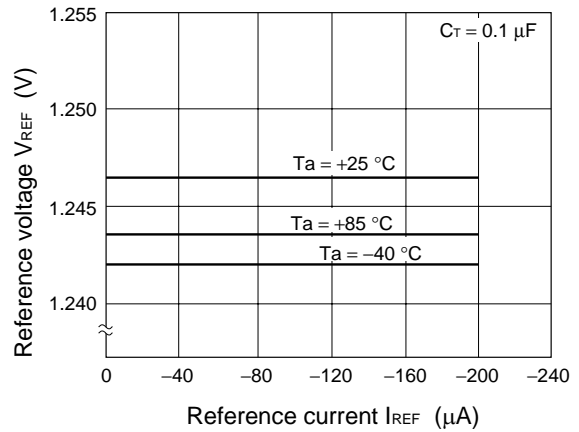

Reference voltage vs. Operating ambient temperature

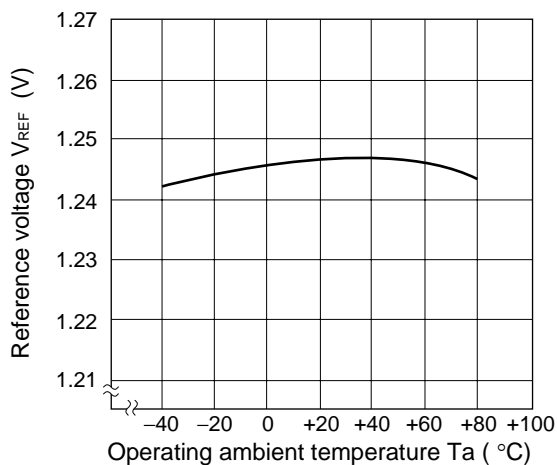

Rising reset hold time vs. Operating ambient temperature

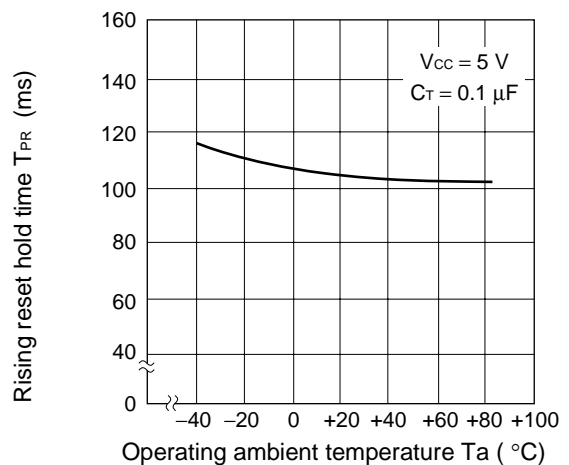

(Continued)

(Continued)

Reset time vs. Operating ambient temperature
(At watch-dog timer)

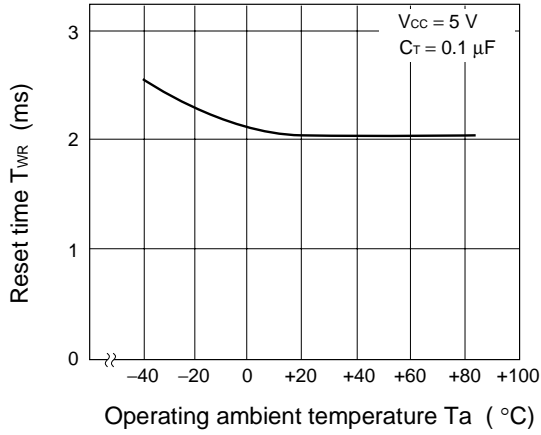

Watch-dog timer watching time vs. Operating ambient temperature

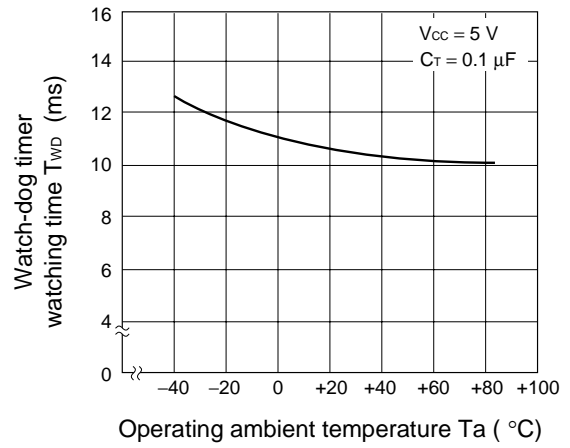

Watch-dog timer watching time vs. C_T terminal capacitance

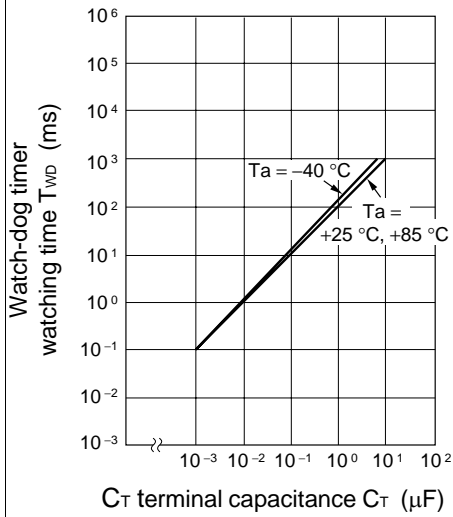

Reset time vs. C_T terminal capacitance
(at watch-dog timer)

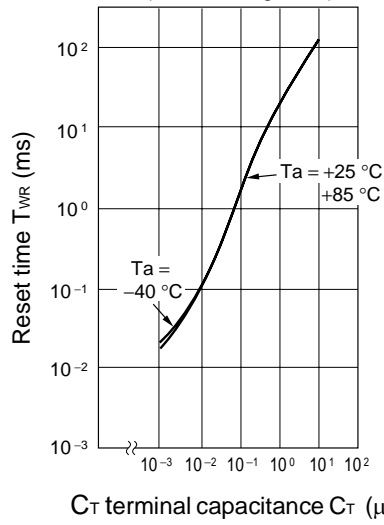

Rising reset hold time vs. C_T terminal capacitance

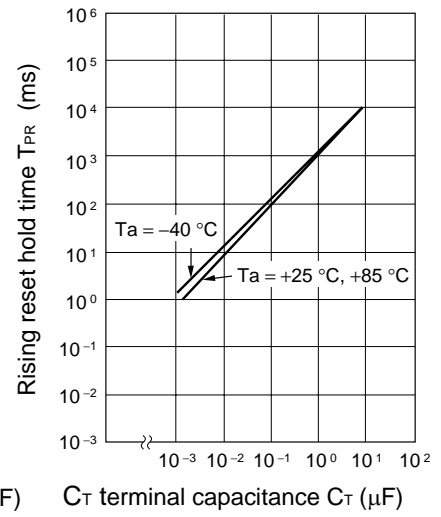

■ APPLICATION CIRCUIT

EXAMPLE 1: Monitoring 5V Supply Voltage and Watch-dog Timer

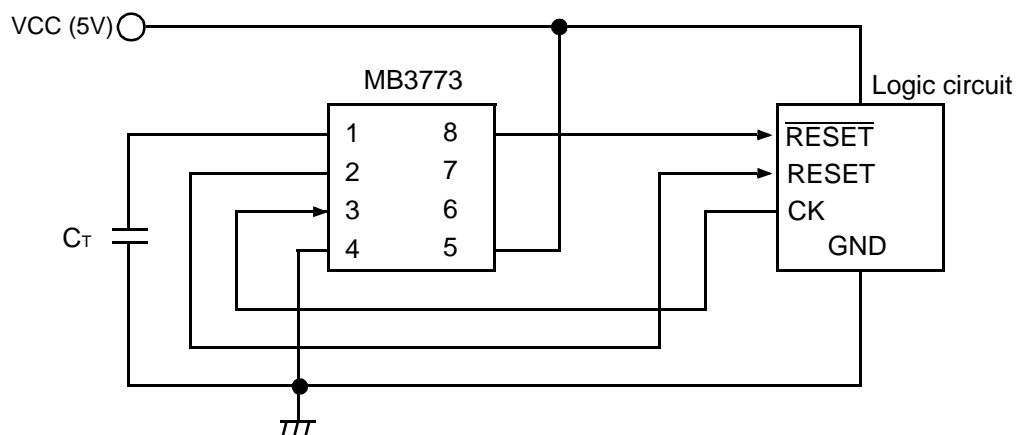

- Notes :
- Supply voltage is monitored using V_s .
 - Detection voltage are V_{SH} and V_{SL} .

EXAMPLE 2: 5V Supply Voltage Monitoring (external fine-tuning type)

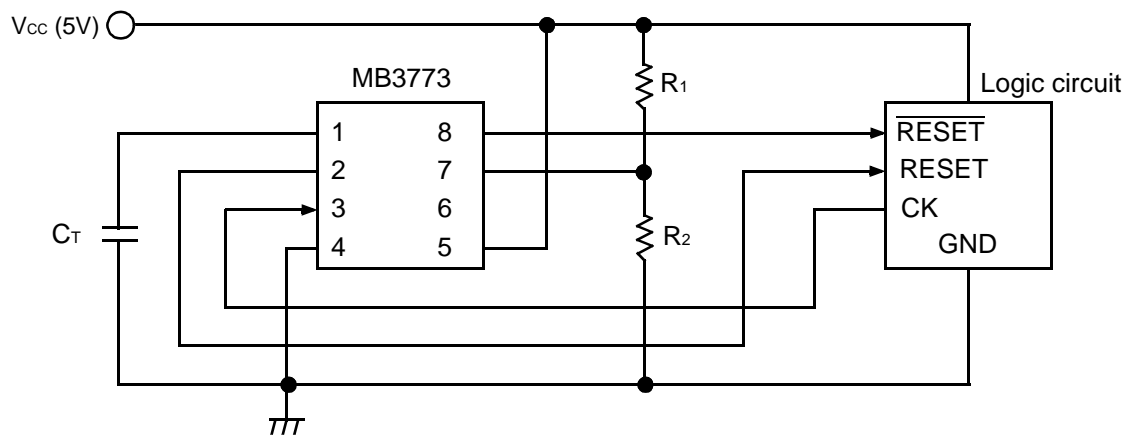

- Notes :
- V_s detection voltage can be adjusted externally.
 - Based on selecting R_1 and R_2 values that are sufficiently lower than the resistance of the IC's internal voltage divider, the detection voltage can be set according to the resistance ratio of R_1 and R_2 (Refer to the table below.)

R_1 (k Ω)	R_2 (k Ω)	Detection voltage: V_{SL} (V)	Detection voltage: V_{SH} (V)
10	3.9	4.4	4.5
9.1	3.9	4.1	4.2

EXAMPLE 3: With Forced Reset (with reset hold)

(a)

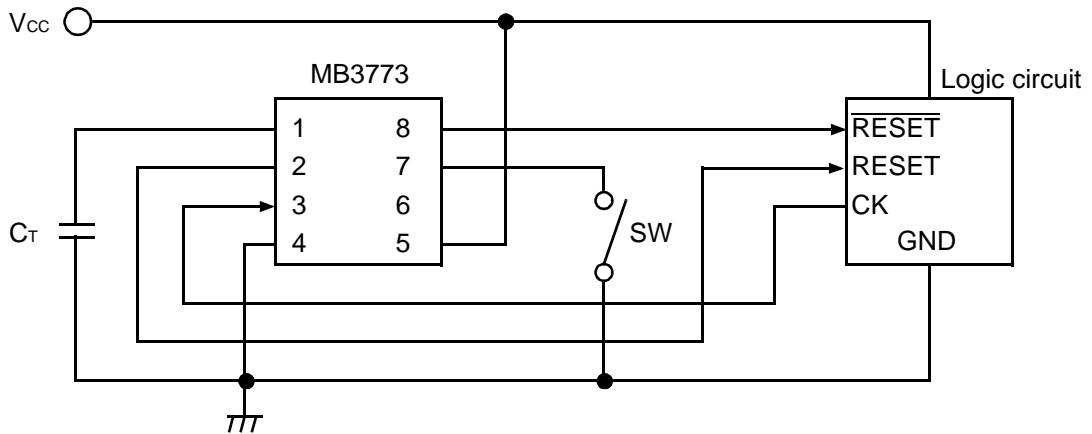

Note : Grounding pin 7 at the time of SW ON sets $\overline{\text{RESET}}$ (pin 8) to Low and RESET (pin 2) to High.

(b)

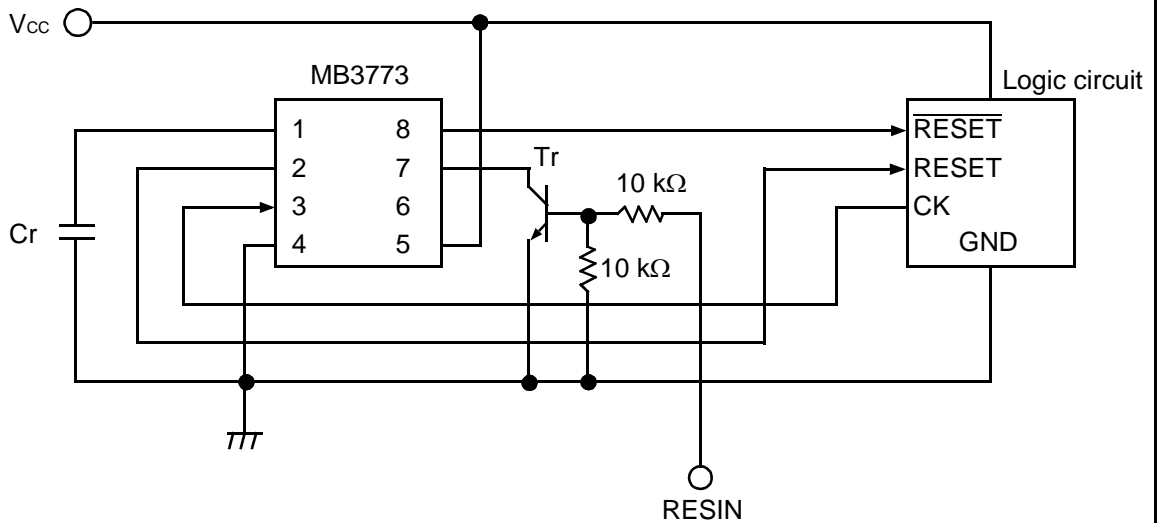

Note : Feeding the signal to terminal RESIN and turning on Tr sets the $\overline{\text{RESET}}$ terminal to Low and the RESET terminal to High.

EXAMPLE 4: Monitoring Two Supply Voltages (with hysteresis, reset output and $\overline{\text{NMI}}$)

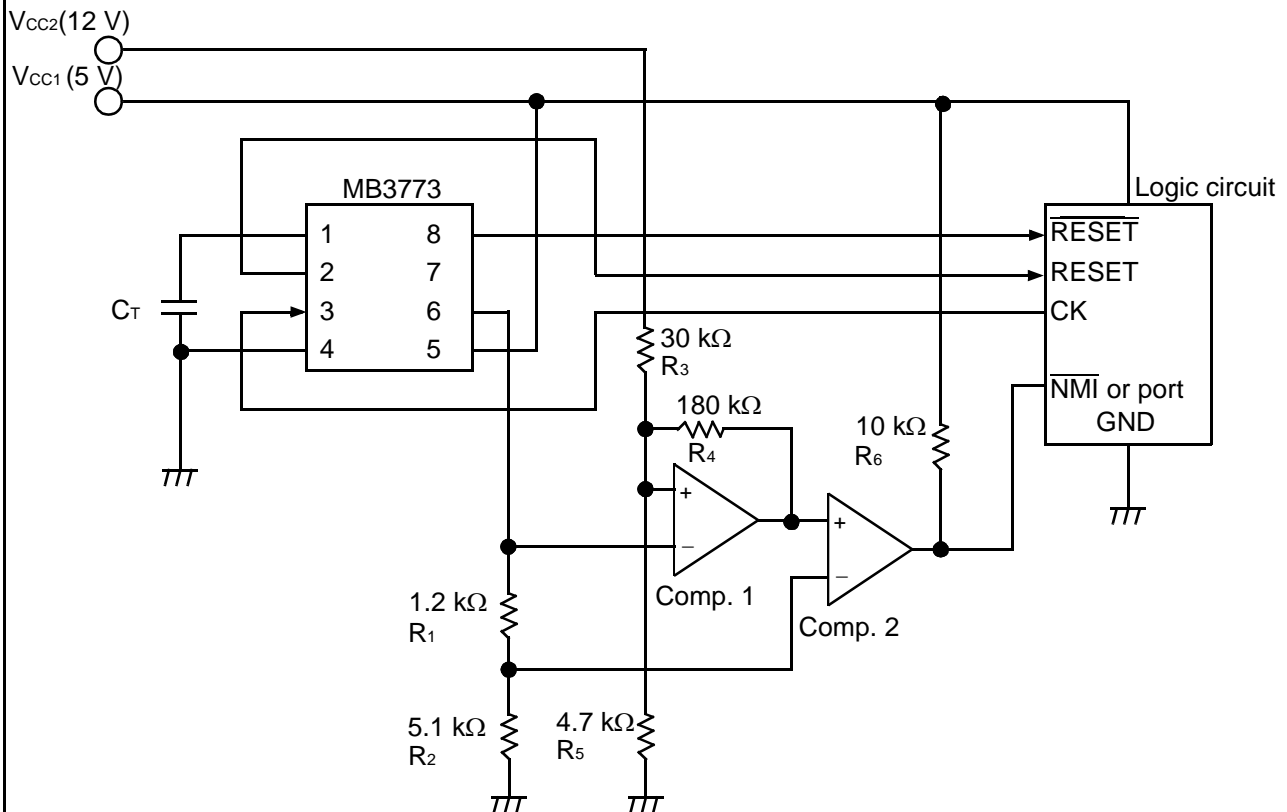

Example : Comp. 1, Comp. 2
: MB4204, MB47393

- Notes :
- The 5 V supply voltage is monitored by the MB3773.
 - The 12 V supply voltage is monitored by the external circuit. Its output is connected to the $\overline{\text{NMI}}$ terminal and, when voltage drops, Comp. 2 interrupts the logic circuit.
 - Use V_{CC1} (= 5 V) to power the comparators (Comp. 1 and Comp. 2) in the external circuit shown above.
 - The detection voltage of the V_{CC2} (= 12 V) supply voltage is approximately 9.2 V/9.4 V and has a hysteresis width of approximately 0.2 V.
 V_{CC2} detection voltage and hysteresis width can be found using the following formulas:

$$\rightarrow \text{Detection voltage } V_{2H} = \frac{R_3 + (R_4 // R_5)}{R_4 // R_5} \times V_{REF} \quad (\text{Approximately 9.4 V in the above illustration})$$

$$V_{2L} = \frac{R_3 + R_5}{R_5} \times V_{REF} \quad (\text{Approximately 9.2 V in the above illustration})$$

$$\rightarrow \text{Hysteresis width } V_{HYS} = V_{2H} - V_{2L}$$

MB3773

EXAMPLE 5: Monitoring Two Supply Voltages (with hysteresis and reset output)

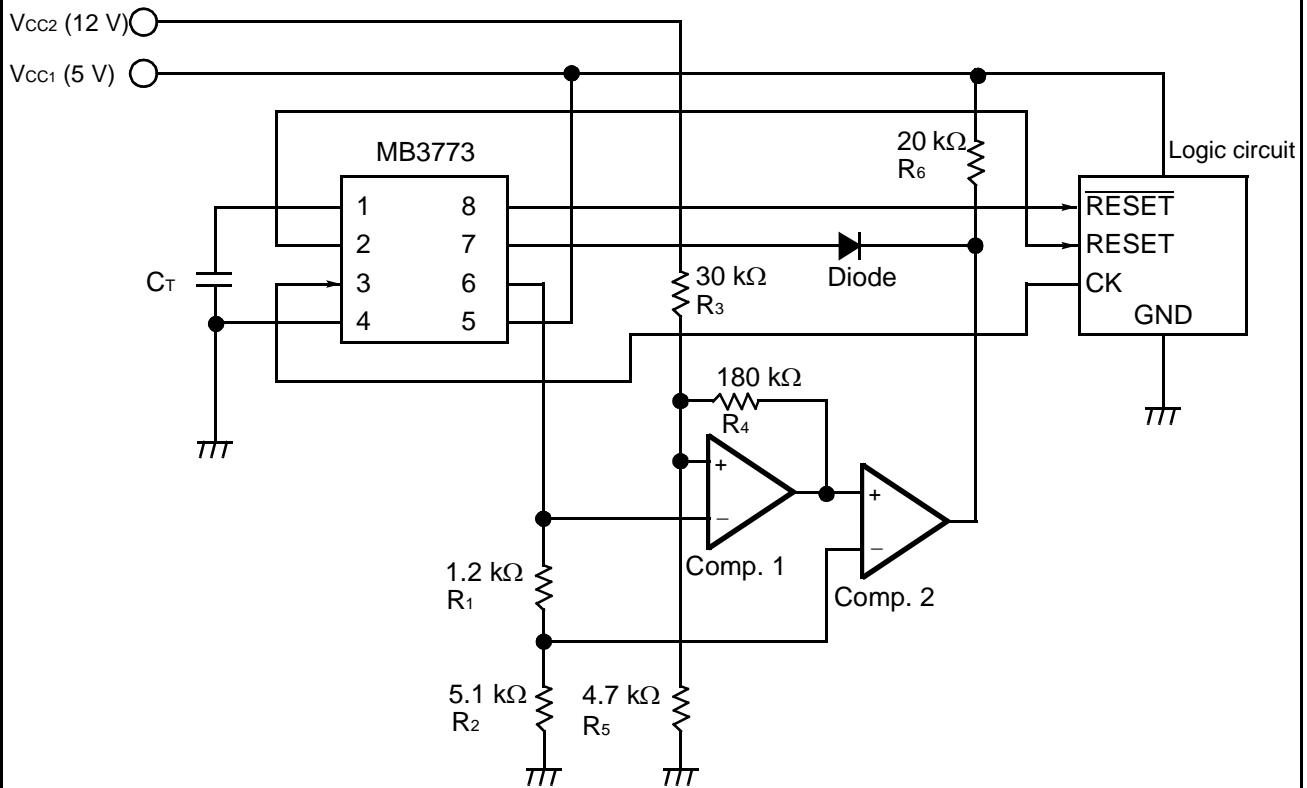

Example : Comp. 1, Comp. 2
: MB4204, MB47393

- Notes :
- When either 5 V or 12 V supply voltage decreases below its detection voltage (V_{SL}), the MB3773 RESET terminal is set to High and the MB3773 \overline{RESET} terminal is set to Low.
 - Use V_{CC1} (= 5 V) to power the comparators (Comp. 1 and Comp. 2) in the external circuit shown above.
 - The detection voltage of the V_{CC2} (= 12 V) supply voltage is approximately 9.2 V/9.4 V and has a hysteresis width of approximately 0.2 V. For the formulas for finding hysteresis width and detection voltage, refer to section 4.

EXAMPLE 6: Monitoring Low voltage and Overvoltage Monitoring (with hysteresis)

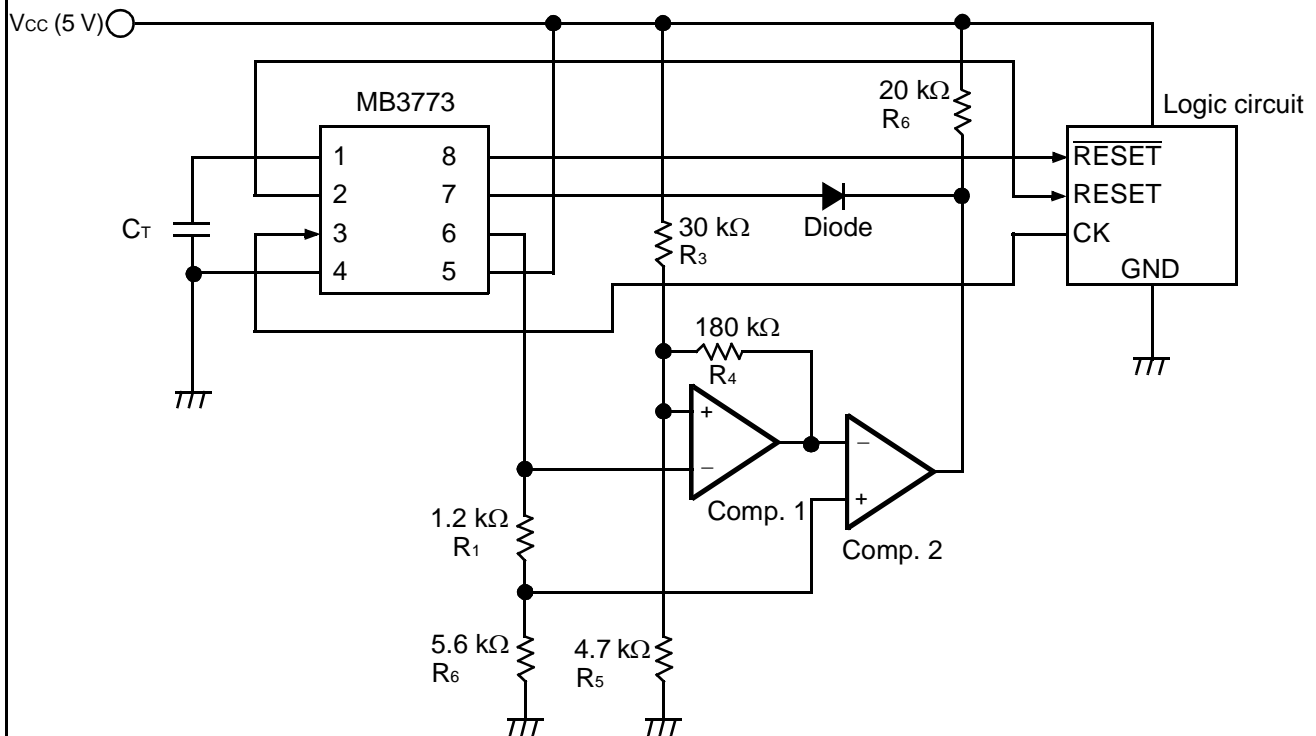

Example : Comp. 1, Comp. 2
: MB4204, MB47393

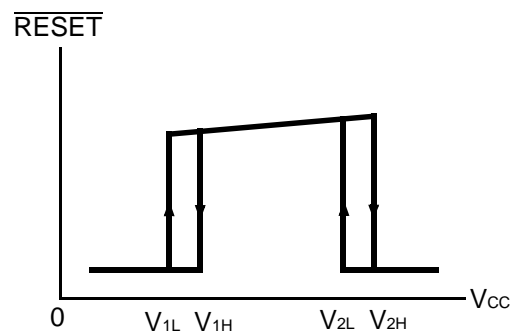

- Notes :
- Comp. 1 and Comp. 2 are used to monitor for overvoltage while the MB3773 is used to monitor for low voltage. Detection voltages V_{1L}/V_{1H} at the time of low voltage are approximately 4.2 V/4.3 V. Detection voltages V_{2L}/V_{2H} at the time of overvoltage are approximately 6.0 V/6.1 V. For the formulas for finding hysteresis width and detection voltage, see EXAMPLE 4.
 - Use V_{CC} (= 5 V) to power the comparators (Comp. 1 and Comp. 2) in the external circuit shown above.

MB3773

EXAMPLE 7: Monitoring Supply Voltage Using Delayed Trigger

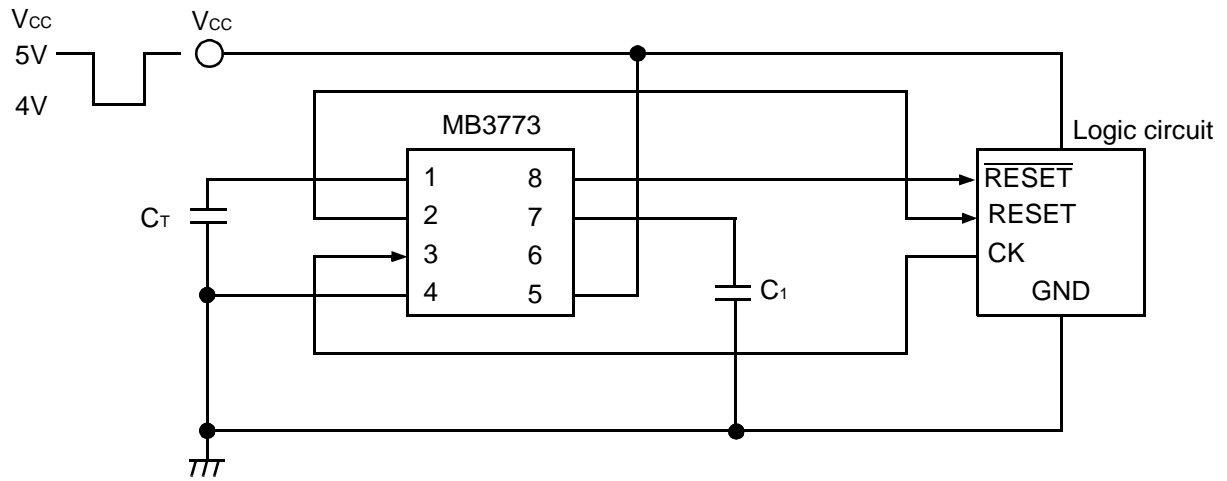

Note : Adding voltage such as shown in the figure to V_{CC} increases the minimum input pulse width by 50 μs (C₁ = 1000 pF).

EXAMPLE 8: Stopping Watch-dog Timer (Monitoring only supply voltage)

These are example application circuits in which the MB3773 monitors supply voltage alone without resetting the microprocessor even if the latter, used in standby mode, stops sending the clock pulse to the MB3773.

- The watch-dog timer is inhibited by clamping the C_T terminal voltage to V_{REF} .

The supply voltage is constantly monitored even while the watch-dog timer is inhibited.

For this reason, a reset signal is output at the occurrence of either instantaneous disruption or a sudden drop to low voltage.

Note that in application examples (a) and (b), the hold signal is inactive when the watch-dog timer is inhibited at the time of resetting.

If the hold signal is active when tie microprocessor is reset, the solution is to add a gate, as in examples (c) and (d).

(a) Using NPN transistor

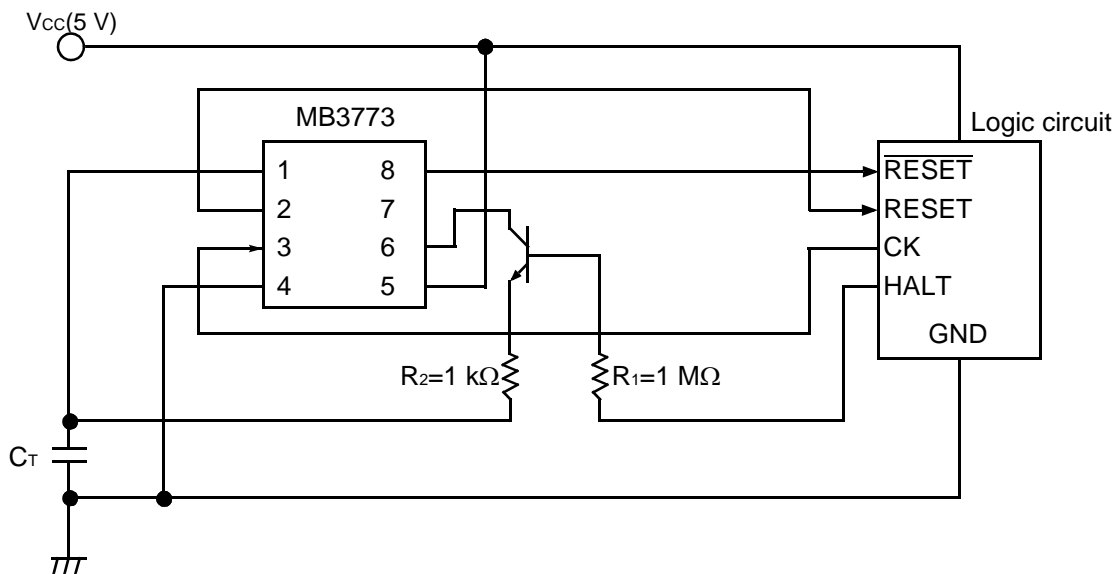

(b) Using PNP transistor

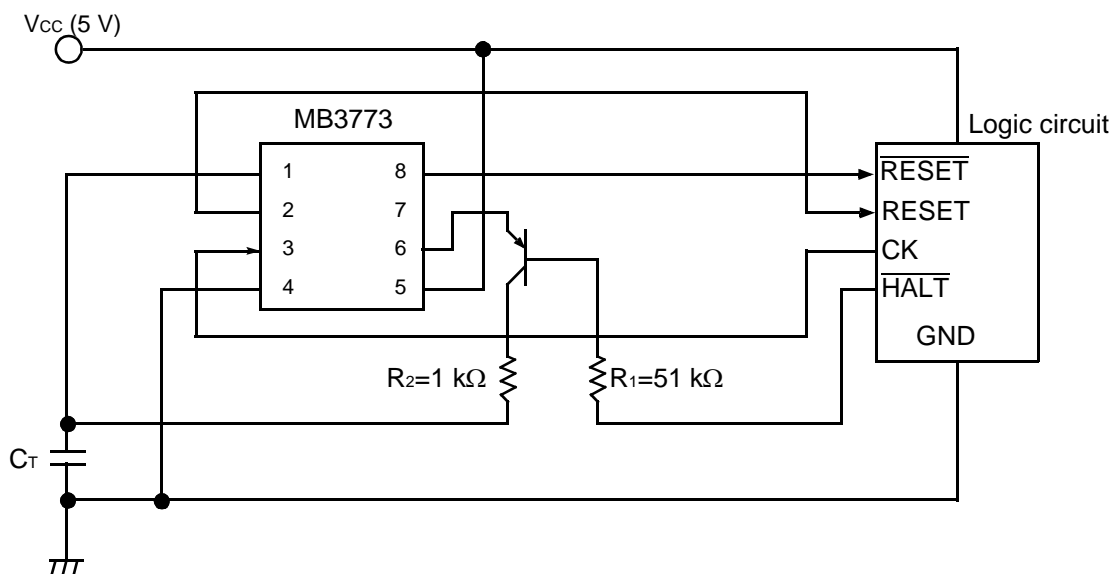

(Continued)

MB3773

(Continued)

(c) Using NPN transistor

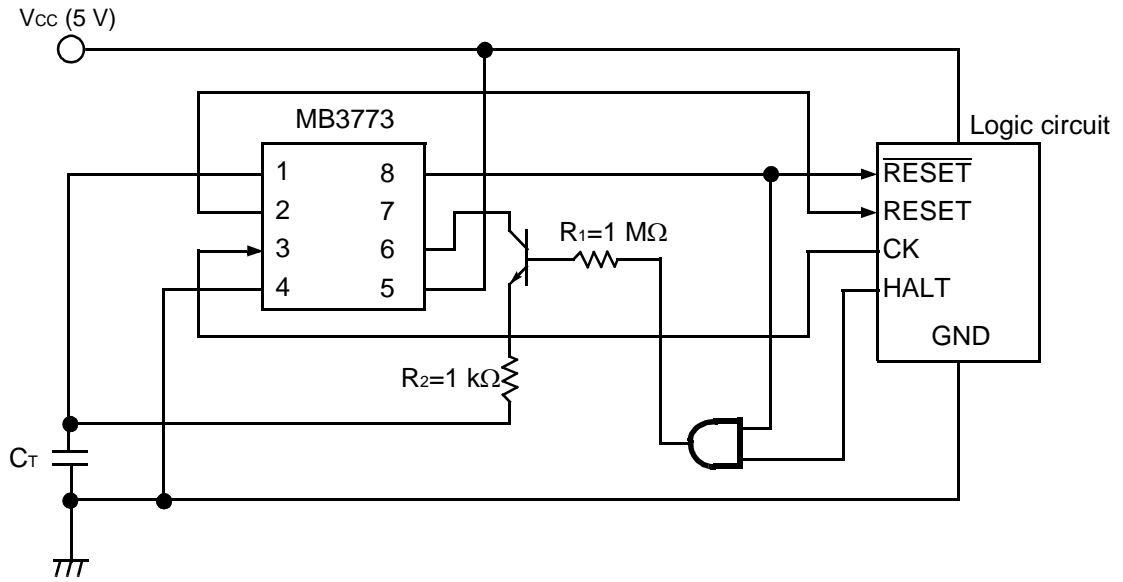

(d) Using PNP transistor

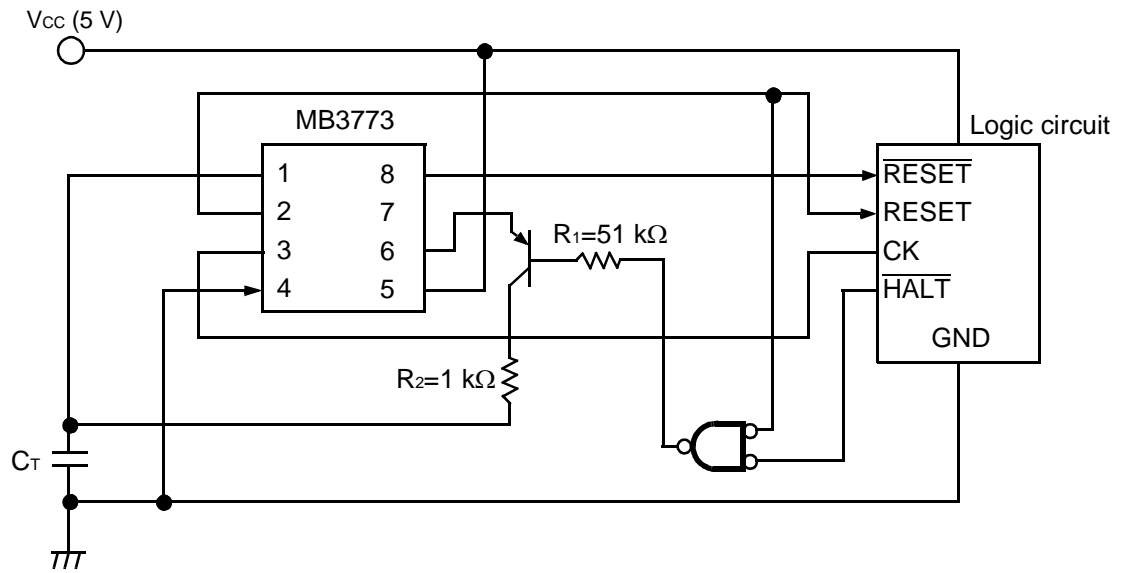

EXAMPLE 9: Reducing Reset Hold Time

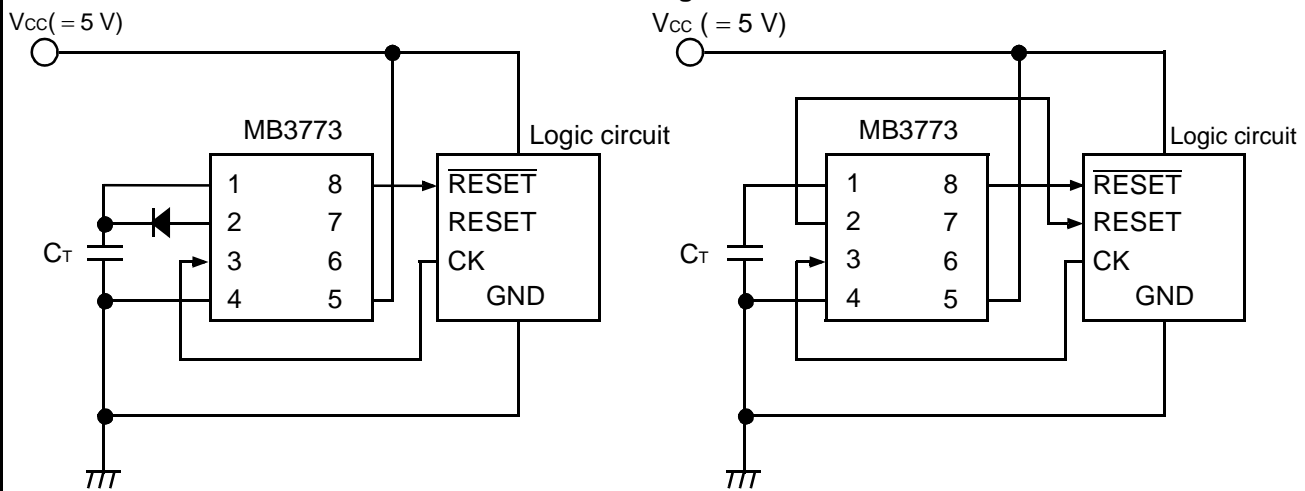

(a) T_{PR} reduction method

(b) Standard usage

- Notes :
- $\overline{\text{RESET}}$ is the only output that can be used.
 - Standard T_{PR} , T_{WD} and T_{WR} value can be found using the following formulas.
 Formulas: $T_{PR} \text{ (ms)} \doteq 100 \times C_T \text{ (}\mu\text{F)}$
 $T_{WD} \text{ (ms)} \doteq 100 \times C_T \text{ (}\mu\text{F)}$
 $T_{WR} \text{ (ms)} \doteq 16 \times C_T \text{ (}\mu\text{F)}$
 - The above formulas become standard values in determining T_{PR} , T_{WD} and T_{WR} .
 Reset hold time is compared below between the reduction circuit and the standard circuit.

$C_T = 0.1 \mu\text{F}$

	T_{PR} reduction circuit	Standard circuit
$T_{PR} \doteq$	10 ms	100 ms
$T_{WD} \doteq$	10 ms	10 ms
$T_{WR} \doteq$	1.6 ms	2.0 ms

EXAMPLE 10: Circuit for Monitoring Multiple Microprocessor

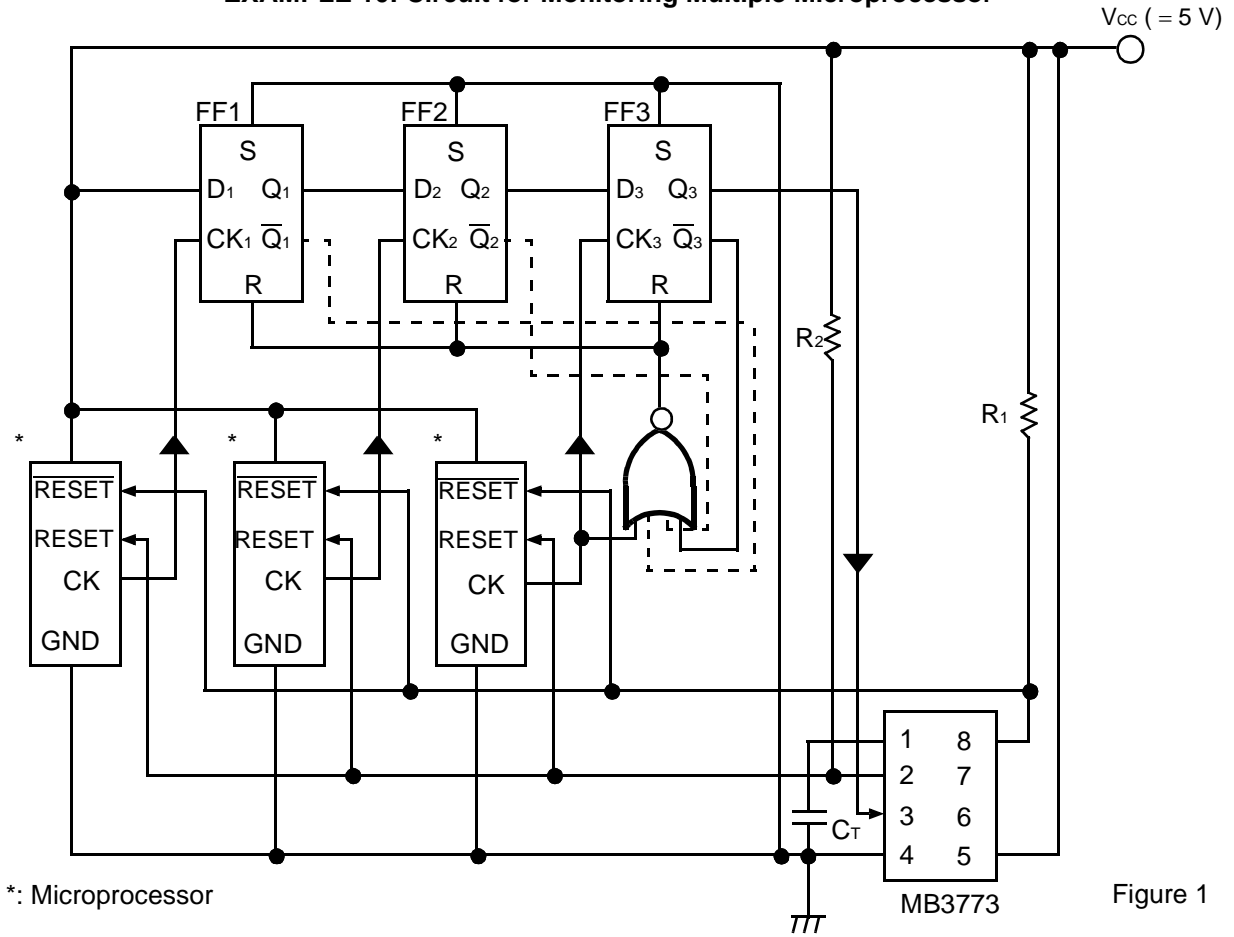

*: Microprocessor

- Notes :
- - - - - connects from FF1 and FF2 outputs \bar{Q}_1 and \bar{Q}_2 to the NOR input.
 - Depending on timing, these connections may not be necessary.
 - Example : $R_1 = R_2 = 2.2 \text{ k}\Omega$
 $C_T = 0.1 \text{ }\mu\text{F}$

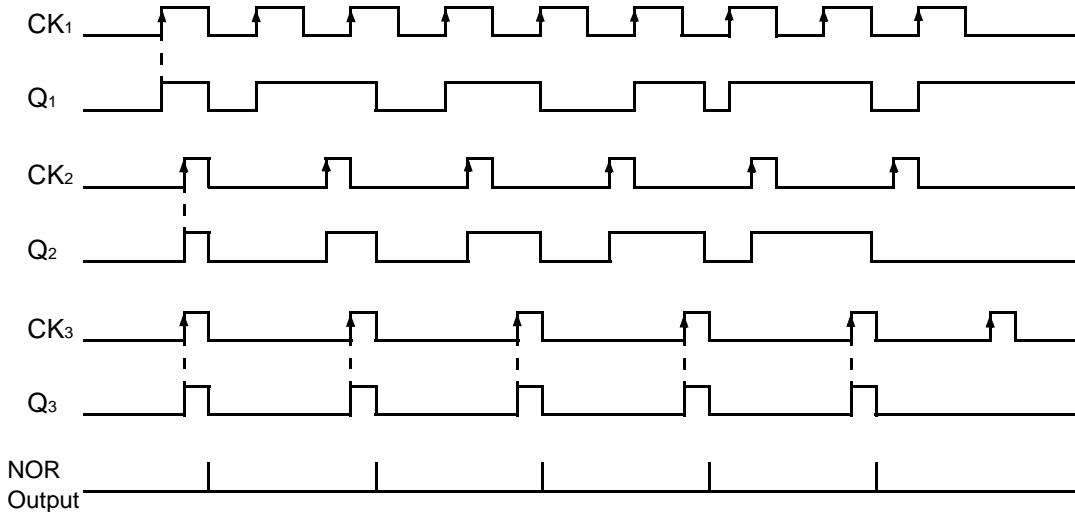

Figure 2

Description of Application Circuits

Using one MB3773, this application circuit monitors multiple microprocessor in one system. Signals from each microprocessor are sent to FF1, FF2 and FF3 clock inputs. Figure 2 shows these timings. Each flip-flop operates using signals sent from microprocessor as its clock pulse. When even one signal stops, the relevant receiving flip-flop stops operating. As a result, cyclical pulses are not generated at output Q₃. Since the clock pulse stops arriving at the CK terminal of the MB3773, the MB3773 generates a reset signal.

Note that output Q₃ frequency f will be in the following range, where the clock frequencies of CK₁, CK₂ and CK₃ are f_1 , f_2 and f_3 respectively.

$$\Rightarrow \frac{1}{f_0} \leq \frac{1}{f} \leq \frac{1}{f_1} + \frac{1}{f_2} + \frac{1}{f_3}$$

where f_0 is the lowest frequency among f_1 , f_2 and f_3 .

EXAMPLE 11: Circuit for Limiting Upper Clock Input Frequency

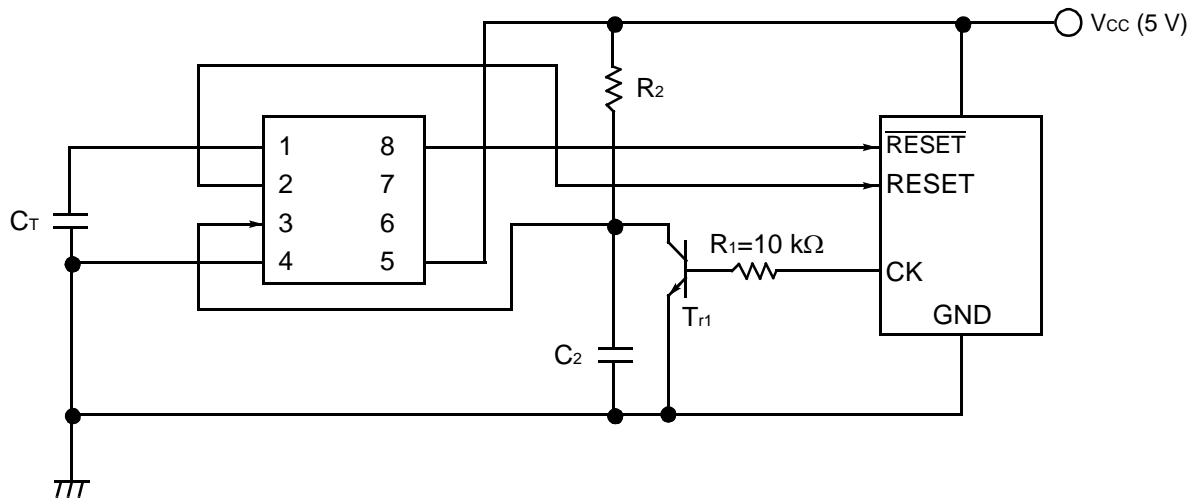

- Notes :
- This is an example application to limit upper frequency f_H of clock pulses sent from the microprocessor.
If the CK cycle sent from the microprocessor exceeds f_H , the circuit generates a reset signal. (The lower frequency has already been set using C_T .)
 - When a clock pulse such as shown below is sent to terminal CK, a short T_2 prevents C_2 voltage from reaching the CK input threshold level (≈ 1.25 V), and will cause a reset signal to be output. The T_1 value can be found using the following formula :

$$T_1 \approx 0.3 C_2 R_2$$

where $V_{cc} = 5$ V, $T_3 \geq 3.0$ μ s, $T_2 \geq 20$ μ s

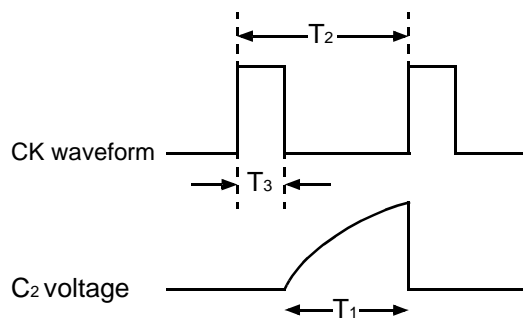

Example : Setting C and R allow the upper T_1 value to be set (Refer to the table below).

C	R	T_1
0.01 μ F	10 k Ω	30 μ s
0.1 μ F	10 k Ω	300 μ s

■ NOTES ON USE

- Take account of common impedance when designing the earth line on a printed wiring board.
- Take measures against static electricity.
 - For semiconductors, use antistatic or conductive containers.
 - When storing or carrying a printed circuit board after chip mounting, put it in a conductive bag or container.
 - The work table, tools and measuring instruments must be grounded.
 - The worker must put on a grounding device containing 250 kΩ to 1 MΩ resistors in series.
- Do not apply a negative voltage
 - Applying a negative voltage of -0.3 V or less to an LSI may generate a parasitic transistor, resulting in malfunction.

■ ORDERING INFORMATION

Part number	Package	Remarks
MB3773PF-□□□	8-pin plastic SOP (FPT-8P-M01)	Conventional version
MB3773PF-□□□E1	8-pin plastic SOP (FPT-8P-M01)	Lead Free version

■ RoHS Compliance Information of Lead (Pb) Free version

The LSI products of Fujitsu Microelectronics with “E1” are compliant with RoHS Directive , and has observed the standard of lead, cadmium, mercury, Hexavalent chromium, polybrominated biphenyls (PBB) , and polybrominated diphenyl ethers (PBDE) .

The product that conforms to this standard is added “E1” at the end of the part number.

■ MARKING FORMAT (Lead Free version)

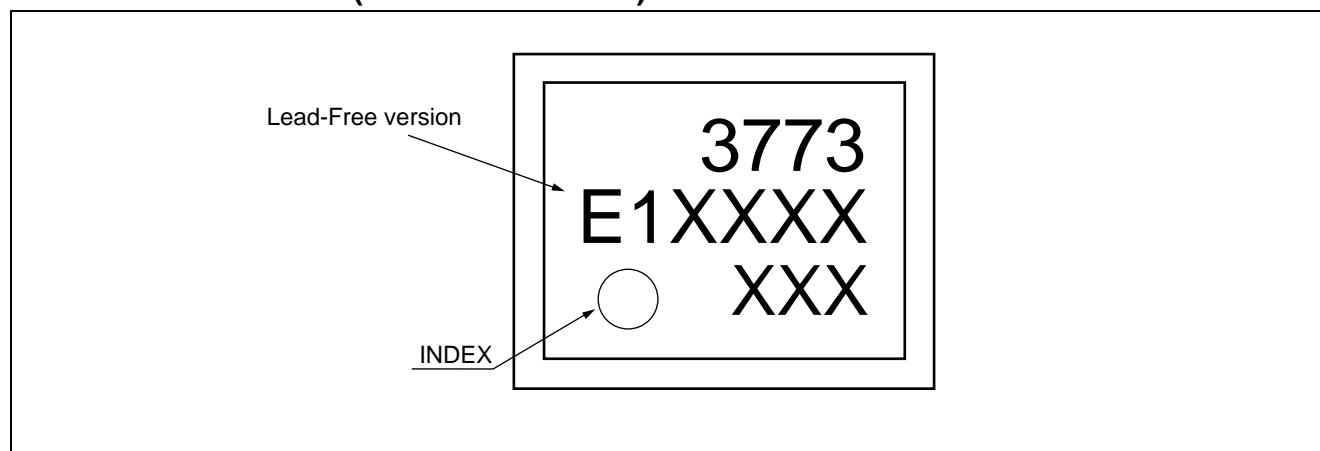

■ LABELING SAMPLE (Lead free version)

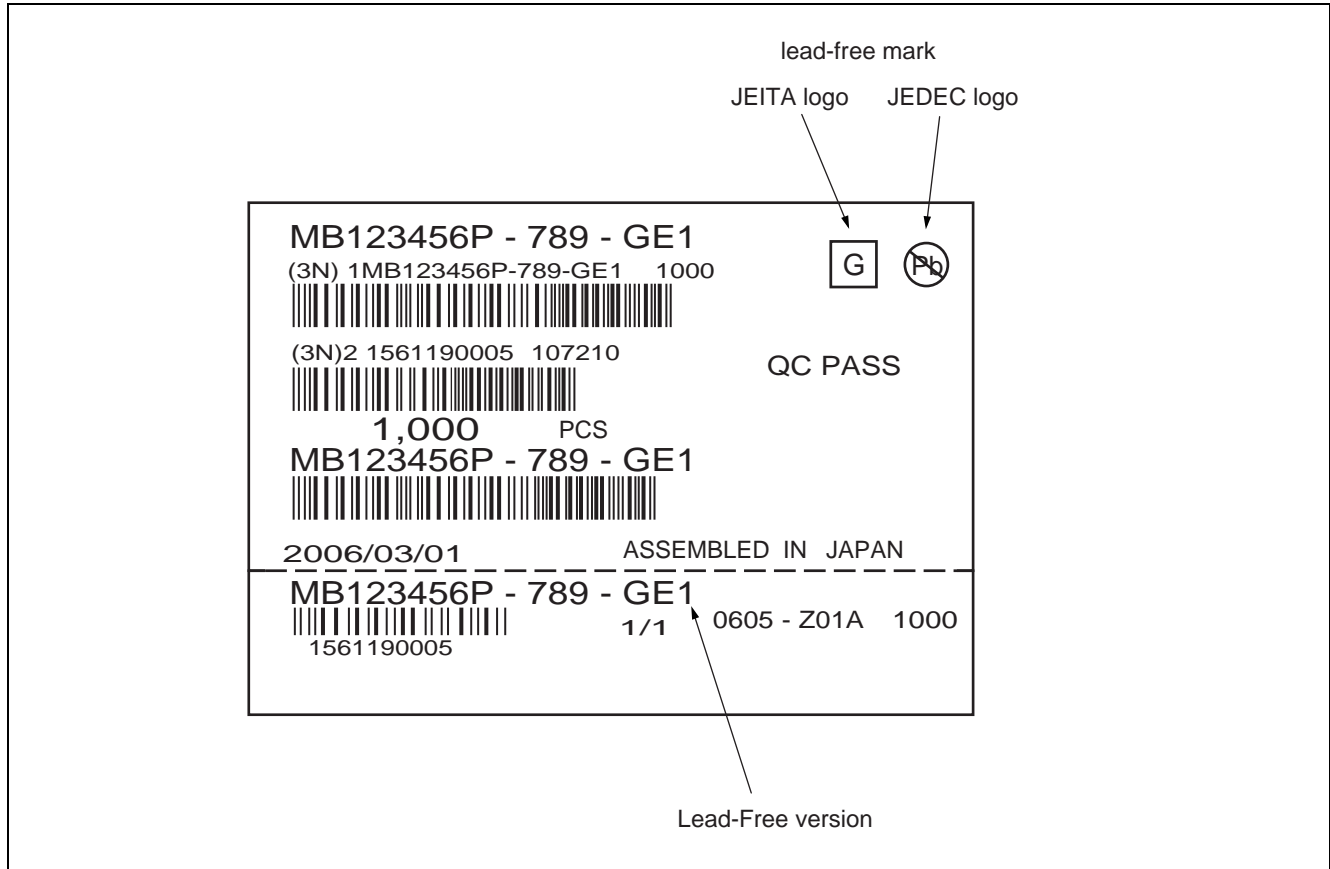

■ MB3773PF-□□□E1 RECOMMENDED CONDITIONS OF MOISTURE SENSITIVITY LEVEL

Item	Condition	
Mounting Method	IR (infrared reflow) , Manual soldering (partial heating method)	
Mounting times	2 times	
Storage period	Before opening	Please use it within two years after Manufacture.
	From opening to the 2nd reflow	Less than 8 days
	When the storage period after opening was exceeded	Please processes within 8 days after baking (125 °C, 24h)
Storage conditions	5 °C to 30 °C, 70%RH or less (the lowest possible humidity)	

[Temperature Profile for FJ Standard IR Reflow]

(1) IR (infrared reflow)

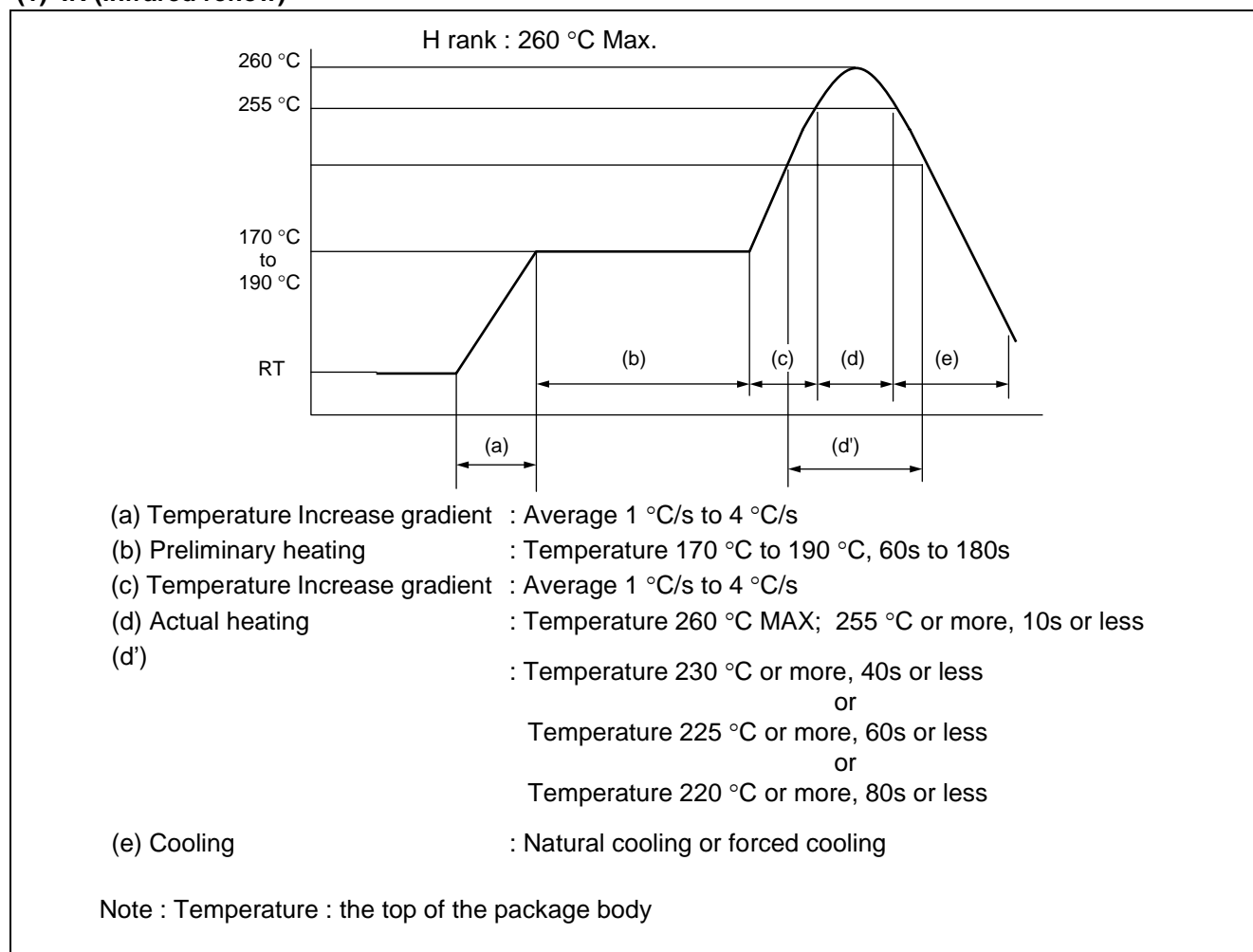

(2) Manual soldering (partial heating method)

Conditions : Temperature 400 °C MAX

Times : 5 s max/pin

MB3773

PACKAGE DIMENSION

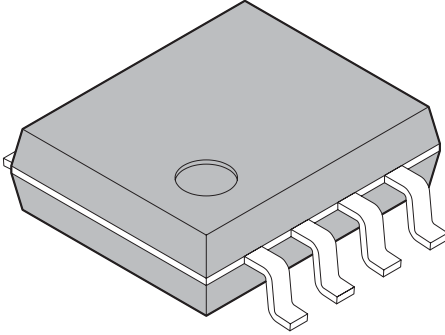
<p style="text-align: center;">8-pin plastic SOP</p>  <p style="text-align: center;">(FPT-8P-M01)</p>	Lead pitch	1.27 mm
	Package width × package length	5.3 × 6.35 mm
	Lead shape	Gullwing
	Sealing method	Plastic mold
	Mounting height	2.25 mm MAX
	Weight	0.10 g
	Code (Reference)	P-SOP8-5.3×6.35-1.27

8-pin plastic SOP
(FPT-8P-M01)

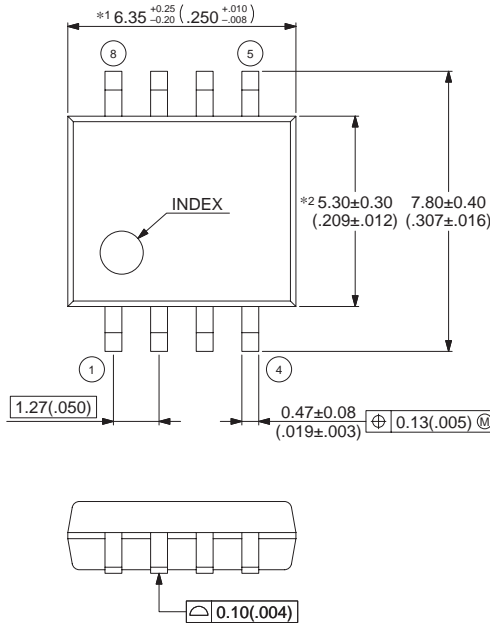

Note 1) *1 : These dimensions include resin protrusion.
 Note 2) *2 : These dimensions do not include resin protrusion.
 Note 3) Pins width and pins thickness include plating thickness.
 Note 4) Pins width do not include tie bar cutting remainder.

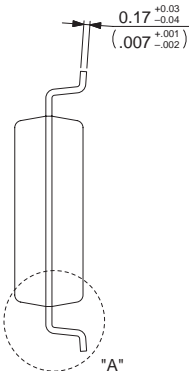

Details of "A" part

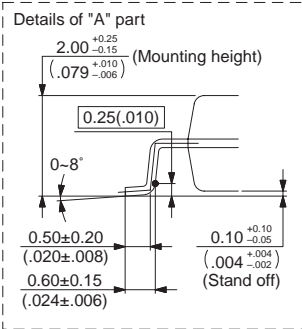

© 2002 FUJITSU LIMITED F08002S-c-6-7

Dimensions in mm (inches).
Note: The values in parentheses are reference values.

MEMO

MEMO

MEMO

FUJITSU MICROELECTRONICS LIMITED

Shinjuku Dai-Ichi Seimei Bldg. 7-1, Nishishinjuku 2-chome, Shinjuku-ku,
Tokyo 163-0722, Japan Tel: +81-3-5322-3347 Fax: +81-3-5322-3387
<http://jp.fujitsu.com/fml/en/>

For further information please contact:

North and South America

FUJITSU MICROELECTRONICS AMERICA, INC.
1250 E. Arques Avenue, M/S 333
Sunnyvale, CA 94085-5401, U.S.A.
Tel: +1-408-737-5600 Fax: +1-408-737-5999
<http://www.fma.fujitsu.com/>

Europe

FUJITSU MICROELECTRONICS EUROPE GmbH
Pittlerstrasse 47, 63225 Langen,
Germany
Tel: +49-6103-690-0 Fax: +49-6103-690-122
<http://emea.fujitsu.com/microelectronics/>

Korea

FUJITSU MICROELECTRONICS KOREA LTD.
206 KOSMO TOWER, 1002 Daechi-Dong,
Kangnam-Gu, Seoul 135-280
Korea
Tel: +82-2-3484-7100 Fax: +82-2-3484-7111
<http://www.fmk.fujitsu.com/>

Asia Pacific

FUJITSU MICROELECTRONICS ASIA PTE LTD.
151 Lorong Chuan, #05-08 New Tech Park,
Singapore 556741
Tel: +65-6281-0770 Fax: +65-6281-0220
<http://www.fujitsu.com/sg/services/micro/semiconductor/>

FUJITSU MICROELECTRONICS SHANGHAI CO., LTD.
Rm.3102, Bund Center, No.222 Yan An Road(E),
Shanghai 200002, China
Tel: +86-21-6335-1560 Fax: +86-21-6335-1605
<http://cn.fujitsu.com/fmc/>

FUJITSU MICROELECTRONICS PACIFIC ASIA LTD.
10/F., World Commerce Centre, 11 Canton Road
Tsimshatsui, Kowloon
Hong Kong
Tel: +852-2377-0226 Fax: +852-2376-3269
<http://cn.fujitsu.com/fmc/tw>

All Rights Reserved.

The contents of this document are subject to change without notice.

Customers are advised to consult with sales representatives before ordering.

The information, such as descriptions of function and application circuit examples, in this document are presented solely for the purpose of reference to show examples of operations and uses of FUJITSU MICROELECTRONICS device; FUJITSU MICROELECTRONICS does not warrant proper operation of the device with respect to use based on such information. When you develop equipment incorporating the device based on such information, you must assume any responsibility arising out of such use of the information.

FUJITSU MICROELECTRONICS assumes no liability for any damages whatsoever arising out of the use of the information.

Any information in this document, including descriptions of function and schematic diagrams, shall not be construed as license of the use or exercise of any intellectual property right, such as patent right or copyright, or any other right of FUJITSU MICROELECTRONICS or any third party or does FUJITSU MICROELECTRONICS warrant non-infringement of any third-party's intellectual property right or other right by using such information. FUJITSU MICROELECTRONICS assumes no liability for any infringement of the intellectual property rights or other rights of third parties which would result from the use of information contained herein.

The products described in this document are designed, developed and manufactured as contemplated for general use, including without limitation, ordinary industrial use, general office use, personal use, and household use, but are not designed, developed and manufactured as contemplated (1) for use accompanying fatal risks or dangers that, unless extremely high safety is secured, could have a serious effect to the public, and could lead directly to death, personal injury, severe physical damage or other loss (i.e., nuclear reaction control in nuclear facility, aircraft flight control, air traffic control, mass transport control, medical life support system, missile launch control in weapon system), or (2) for use requiring extremely high reliability (i.e., submersible repeater and artificial satellite).

Please note that FUJITSU MICROELECTRONICS will not be liable against you and/or any third party for any claims or damages arising in connection with above-mentioned uses of the products.

Any semiconductor devices have an inherent chance of failure. You must protect against injury, damage or loss from such failures by incorporating safety design measures into your facility and equipment such as redundancy, fire protection, and prevention of over-current levels and other abnormal operating conditions.

Exportation/release of any products described in this document may require necessary procedures in accordance with the regulations of the Foreign Exchange and Foreign Trade Control Law of Japan and/or US export control laws.

The company names and brand names herein are the trademarks or registered trademarks of their respective owners.