

TAS5731M 2 x 30-W Digital Audio Power Amplifier With DSP and 2.1 Mode

1 Features

- 2-Ch I²S Input; 8-kHz to 48-kHz f_s
- 30-W Stereo, 8 Ω /24 V (THD+N = 10%)
- Up to 90% Efficient Operation
- Wide 8-V to- 24-V Supply Range; 3.3-V Digital Supply
- Single-Device 2.1 Support (2 x SE + 1 x BTL)
- 80-m Ω $R_{DS(on)}$ Device That Can Support 2- Ω SE and 4- Ω BTL Modes
 - 12 V, 2 Ω , 8 W With SE mode
 - 12 V, 4 Ω , 15 W With BTL mode
- Speaker EQ (8 BQ per Channel), 2x DRCs
- Pin-to-Pin Compatible With the TAS5727 and TAS5731
- Benefits:
 - Direct Connect to Digital Processor
 - High Output Power From a Standard Supply
 - Eliminates the Need for Heat Sink
 - Advanced Processing Improves Audio Experience

2 Applications

- LCD TV
- LED TV
- Sound Bar

3 Description

The TAS5731M is a 30-W, efficient, digital-audio stereo power amplifier for driving stereo bridge-tied speakers. One serial data input allows processing of up to two discrete audio channels and seamless integration to most digital audio processors and MPEG decoders. The device accepts a wide range of input data and data rates. A fully programmable data path routes these channels to the internal speaker drivers.

The TAS5731M is a slave-only device receiving all clocks from external sources. The TAS5731M operates with a PWM carrier between a 384-kHz switching rate and a 352-kHz switching rate, depending on the input sample rate. Oversampling combined with a fourth-order noise shaper provides a flat noise floor and excellent dynamic range from 20 Hz to 20 kHz.

Device Information⁽¹⁾

PART NUMBER	PACKAGE	BODY SIZE (NOM)
TAS5731M	HTQFP (48)	7.00 mm x 7.00 mm

(1) For all available packages, see the orderable addendum at the end of the data sheet.

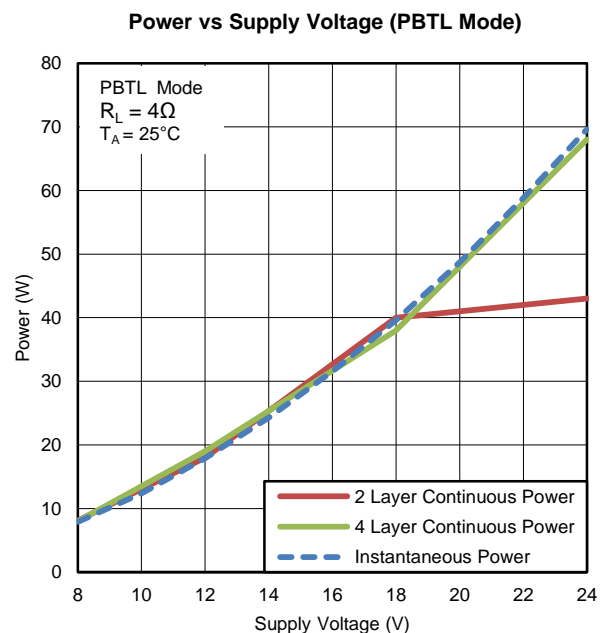
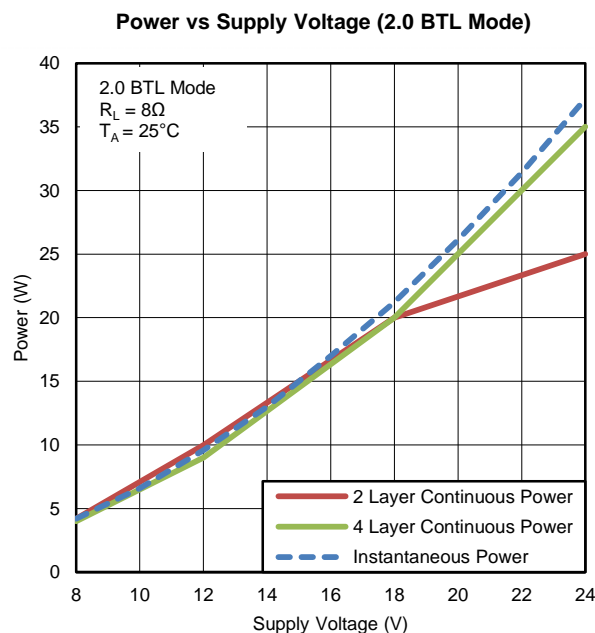

Table of Contents

1 Features 1 2 Applications 1 3 Description 1 4 Revision History 2 5 Device Comparison Table 3 6 Pin Configuration and Functions 4 7 Specifications 6 7.1 Absolute Maximum Ratings 6 7.2 ESD Ratings..... 6 7.3 Recommended Operating Conditions 7 7.4 Thermal Information 7 7.5 PWM Operation at Recommended Operating Conditions 7 7.6 DC Electrical Characteristics 8 7.7 AC Electrical Characteristics (BTL, PBTL)..... 9 7.8 Electrical Characteristics - PLL External Filter Components..... 9 7.9 Electrical Characteristic - I ² C Serial Control Port Operation 9 7.10 Timing Requirements - PLL Input Parameters 10 7.11 Timing Requirements - Serial Audio Ports Slave Mode 10 7.12 Timing Requirements - I ² C Serial Control Port Operation 10 7.13 Timing Requirements - Reset (RESET)..... 10 7.14 Typical Characteristics 13	8 Parameter Measurement Information 21 9 Detailed Description 21 9.1 Overview 21 9.2 Functional Block Diagrams 21 9.3 Feature Description..... 24 9.4 Device Functional Modes..... 34 9.5 Programming..... 36 9.6 Register Maps 41 10 Application and Implementation 59 10.1 Application Information..... 59 10.2 Typical Applications 59 11 Power Supply Recommendations 69 11.1 DVDD and AVDD Supplies 69 11.2 PVDD Power Supply 69 12 Layout 69 12.1 Layout Guidelines 69 12.2 Layout Examples..... 70 13 Device and Documentation Support 73 13.1 Device Support 73 13.2 Documentation Support 73 13.3 Community Resources..... 73 13.4 Trademarks 73 13.5 Electrostatic Discharge Caution..... 73 13.6 Glossary 73 14 Mechanical, Packaging, and Orderable Information 73
--	--

4 Revision History

NOTE: Page numbers for previous revisions may differ from page numbers in the current version.

Changes from Revision B (November 2013) to Revision C	Page
<ul style="list-style-type: none"> • Added <i>Pin Configuration and Functions</i> section, <i>ESD Ratings</i> table, <i>Feature Description</i> section, <i>Device Functional Modes</i>, <i>Application and Implementation</i> section, <i>Power Supply Recommendations</i> section, <i>Layout</i> section, <i>Device and Documentation Support</i> section, and <i>Mechanical, Packaging, and Orderable Information</i> section 1 	1
Changes from Revision A (November 2013) to Revision B	Page
<ul style="list-style-type: none"> • Changed "2 x 20-W" to "2 x 30-W" in the Title, Features, and Description 1 	1

5 Device Comparison Table

	TAS5731M	TAS5729MD	TAS5721	TAS5717	TAS5711	TAS5707
Max Power to Single-Ended Load	18		10		16	
Max Power to Bridge Tied Load	37	20	15	10	20	20
Max Power to Parallel Bridge Tied Load	70	40	30		40	
Min Supported Single-Ended Load	2		4		4	
Min Supported Bridge Tied Load	4	4	8	4	6	6
Min Supported Parallel Bridge Tied Load	2	4	4		4	
Closed/Open Loop	Open	Open	Open	Open	Open	Open
Max Speaker Outputs	3	2	3	2	3	2
Headphone Channels		Yes	Yes	Yes		
Architecture	Class D	Class D	Class D	Class D	Class D	Class D
Dynamic Range Control (DRC)	2-Band	2-Band AGL	2-Band	2-Band AGL	2-Band	Single-Band
Biquads (EQ)	21	28	21	28	21	14

6 Pin Configuration and Functions

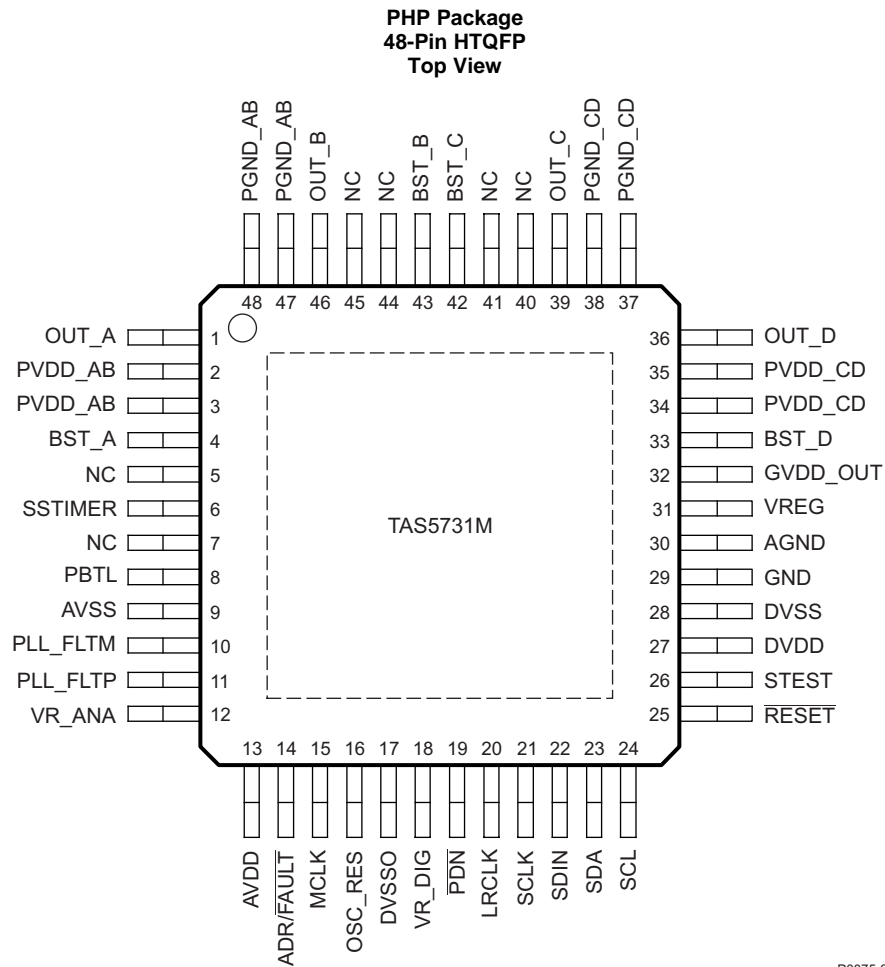

P0075-25

Pin Functions

PIN		TYPE ⁽¹⁾	5-V TOLERANT	TERMINATION ⁽²⁾	DESCRIPTION
NAME	NO.				
AGND	30	P			Local analog ground for power stage, which must be connected to the system ground.
ADR/FAULT	14	DIO			Dual function terminal which sets the LSB of the 7-bit I ² C address to "0" if pulled to GND and to "1" if pulled to DVDD. If configured to be a fault output by the methods described in I²C Address Selection and Fault Output , this terminal is pulled low when an internal fault occurs. A pull-up or pull-down resistor is required, as is shown in the Typical Application Circuit Diagrams. If pulled high (to DVDD), a 15-kΩ resistor must be used to minimize in-rush current at power up and to isolate the net if the pin is used as a fault output, as described above.

(1) TYPE: A = analog; D = 3.3-V digital; P = power/ground/decoupling; I = input; O = output

(2) All pullups are 20-μA weak pullups and all pulldowns are 20-μA weak pulldowns. The pullups and pulldowns are included to assure proper input logic levels if the terminals are left unconnected (pull-ups → logic 1 input; pulldowns → logic 0 input). Devices that drive inputs with pullups must be able to sink 20 μA while maintaining a logic-0 drive level. Devices that drive inputs with pulldowns must be able to source 20 μA while maintaining a logic-1 drive level.

Pin Functions (continued)

PIN		TYPE ⁽¹⁾	5-V TOLERANT	TERMINATION ⁽²⁾	DESCRIPTION
NAME	NO.				
AVDD	13	P			3.3-V analog power supply
AVSS	9	P			Analog 3.3-V supply ground
BST_A	4	P			High-side bootstrap supply for half-bridge A
BST_B	43	P			High-side bootstrap supply for half-bridge B
BST_C	42	P			High-side bootstrap supply for half-bridge C
BST_D	33	P			High-side bootstrap supply for half-bridge D
DVDD	27	P			3.3-V digital power supply
DVSS	28	P			Digital ground
DVSSO	17	P			Oscillator ground
GND	29	P			Analog ground for power stage
GVDD_OUT	32	P			Gate drive internal regulator output
LRCLK	20	DI	5-V	Pulldown	Input serial audio data left/right clock (sample-rate clock)
MCLK	15	DI	5-V	Pulldown	Master clock input
NC	5, 7, 40, 41, 44, 45	–			No connect
OSC_RES	16	AO			Oscillator trim resistor. Connect an 18.2-kΩ, 1% resistor to DVSSO.
OUT_A	1	O			Output, half-bridge A
OUT_B	46	O			Output, half-bridge B
OUT_C	39	O			Output, half-bridge C
OUT_D	36	O			Output, half-bridge D
PBTL	8	DI		Pulldown	Low means BTL mode; high means PBTL mode. Information goes directly to power stage.
$\overline{\text{PDN}}$	19	DI	5-V	Pullup	Power down, active-low. $\overline{\text{PDN}}$ prepares the device for loss of power supplies by shutting down the noise shaper and initiating the PWM stop sequence.
PGND_AB	47, 48	P			Power ground for half-bridges A and B
PGND_CD	37, 38	P			Power ground for half-bridges C and D
PLL_FLTM	10	AO			PLL negative loop-filter terminal
PLL_FLTP	11	AO			PLL positive loop-filter terminal
PVDD_AB	2, 3	P			Power-supply input for half-bridge output A and B
PVDD_CD	34, 35	P			Power-supply input for half-bridge output C and D
$\overline{\text{RESET}}$	25	DI	5-V	Pullup	Reset, active-low. A system reset is generated by applying a logic low to this pin. $\overline{\text{RESET}}$ is an asynchronous control signal that restores the DAP to its default conditions and places the PWM in the hard-mute (high-impedance) state.
SCL	24	DI	5-V		I ² C serial control clock input
SCLK	21	DI	5-V	Pulldown	Serial audio-data clock (shift clock). SCLK is the serial-audio-port input-data bit clock.
SDA	23	DIO	5-V		I ² C serial control data interface input/output
SDIN	22	DI	5-V	Pulldown	Serial audio data input. SDIN supports three discrete (stereo) data formats.
SSTIMER	6	AI			Controls ramp time of OUT_x to minimize pop. Leave this pin floating for BD mode. Requires capacitor of 2.2 nF to GND in AD mode. The capacitor determines the ramp time.
STEST	26	DI			Factory test pin. Connect directly to DVSS.
VR_ANA	12	P			Internally regulated 1.8-V analog supply voltage. This pin must not be used to power external devices.
VR_DIG	18	P			Internally regulated 1.8-V digital supply voltage. This pin must not be used to power external devices.

Pin Functions (continued)

PIN		TYPE ⁽¹⁾	5-V TOLERANT	TERMINATION ⁽²⁾	DESCRIPTION
NAME	NO.				
VREG	31	P			Digital regulator output. Not to be used for powering external circuitry.
PowerPAD™		P			Provides both electrical and thermal connection from the device to the board. A matching ground pad must be provided on the PCB and the device connected to it via solder. For proper electrical operation, this ground pad must be connected to the system ground

7 Specifications

7.1 Absolute Maximum Ratings

 over operating free-air temperature range (unless otherwise noted) ⁽¹⁾

		MIN	MAX	UNIT
Supply voltage	DVDD, AVDD	-0.3	4.2	V
	PVDD_x	-0.3	30	V
Input voltage	3.3-V digital input	-0.5	DVDD + 0.5	V
	5-V tolerant ⁽²⁾ digital input (except MCLK)	-0.5	DVDD + 2.5 ⁽³⁾	
	5-V tolerant MCLK input	-0.5	AVDD + 2.5 ⁽³⁾	
OUT_x to PGND_x			32 ⁽⁴⁾	V
BST_x to PGND_x			39 ⁽⁴⁾	V
Input clamp current, I _{IK}		-20	20	mA
Output clamp current, I _{OK}		-20	20	mA
Operating free-air temperature		0	85	°C
Operating junction temperature		0	150	°C
Storage temperature, T _{stg}		-40	125	°C

(1) Stresses beyond those listed under *Absolute Maximum Ratings* may cause permanent damage to the device. These are stress ratings only and functional operation of the device at these or any other conditions beyond those indicated under *Recommended Operating Conditions* is not implied. Exposure to absolute-maximum conditions for extended periods may affect device reliability.

(2) 5-V tolerant inputs are PDN, RESET, SCLK, LRCLK, MCLK, SDIN, SDA, and SCL.

(3) Maximum pin voltage must not exceed 6 V.

(4) DC voltage + peak ac waveform measured at the pin must be below the allowed limit for all conditions.

7.2 ESD Ratings

		VALUE	UNIT
V _(ESD) Electrostatic discharge	Human body model (HBM), per ANSI/ESDA/JEDEC JS-001 ⁽¹⁾	±1000	V
	Charged-device model (CDM), per JEDEC specification JESD22-C101 ⁽²⁾	±250	

(1) JEDEC document JEP155 states that 500-V HBM allows safe manufacturing with a standard ESD control process.

(2) JEDEC document JEP157 states that 250-V CDM allows safe manufacturing with a standard ESD control process.

7.3 Recommended Operating Conditions

		MIN	NOM	MAX	UNIT		
	Digital/analog supply voltage	DVDD, AVDD		3	3.3	3.6	V
	Half-bridge supply voltage	PVDD_x		8	26.4 ⁽¹⁾		V
V _{IH}	High-level input voltage	5-V tolerant		2			V
V _{IL}	Low-level input voltage	5-V tolerant				0.8	V
T _A	Operating ambient temperature range			0	85		°C
T _J ⁽²⁾	Operating junction temperature range			0	125		°C
R _L (PBTL)	Load impedance	Output filter: L = 15 µH, C = 680 nF		2			Ω
R _L (BTL)	Load impedance	Output filter: L = 15 µH, C = 680 nF		4			Ω
R _L (SE)	Load impedance	Output filter: L = 15 µH, C = 680 nF		2			Ω
L _O	Output-filter inductance	Minimum output inductance under short-circuit condition		10			µH

(1) For operation at PVDD_x levels greater than 18 V, the modulation limit must be set to 93.8% through the control port register 0x10.

(2) Continuous operation above the recommended junction temperature may result in reduced reliability and/or lifetime of the device.

7.4 Thermal Information

THERMAL METRIC ⁽¹⁾		TAS5731M		UNIT
		PHP (HTQFP)		
		48 PINS		
R _{θJA}	Junction-to-ambient thermal resistance	27.9		°C/W
R _{θJC(top)}	Junction-to-case (top) thermal resistance	1.1		°C/W
R _{θJB}	Junction-to-board thermal resistance	13		°C/W
Ψ _{JT}	Junction-to-top characterization parameter	20.7		°C/W
Ψ _{JB}	Junction-to-board characterization parameter	0.3		°C/W
R _{θJC(bot)}	Junction-to-case (bottom) thermal resistance	6.7		°C/W

(1) For more information about traditional and new thermal metrics, see the *Semiconductor and IC Package Thermal Metrics* application report, [SPRA953](#).

7.5 PWM Operation at Recommended Operating Conditions

PARAMETER	TEST CONDITIONS	VALUE	UNIT
Output PWM switch frequency	11.025/22.05/44.1-kHz data rate ±2%	352.8	kHz
	48/24/12/8/16/32-kHz data rate ±2%	384	

7.6 DC Electrical Characteristics

 $T_A = 25^\circ$, $PVDD_x = 18\text{ V}$, $DVDD = AVDD = 3.3\text{ V}$, $R_L = 8\ \Omega$, BTL AD mode, $f_S = 48\text{ kHz}$ (unless otherwise noted)

PARAMETER			TEST CONDITIONS	MIN	TYP	MAX	UNIT
V_{OH}	High-level output voltage	ADR/ $\overline{\text{FAULT}}$ and SDA	$I_{OH} = -4\text{ mA}$ $DVDD = 3\text{ V}$	2.4			V
V_{OL}	Low-level output voltage	ADR/ $\overline{\text{FAULT}}$ and SDA	$I_{OL} = 4\text{ mA}$ $DVDD = 3\text{ V}$			0.5	V
I_{IL}	Low-level input current		$V_I < V_{IL}$; $DVDD = AVDD = 3.6\text{ V}$			75	μA
I_{IH}	High-level input current		$V_I > V_{IH}$; $DVDD = AVDD = 3.6\text{ V}$			75 ⁽¹⁾	μA
I_{DD}	3.3-V supply current	3.3-V supply voltage (DVDD, AVDD)	Normal mode		49	68	mA
			Reset ($\overline{\text{RESET}} = \text{low}$, PDN = high)		23	38	
I_{PVDD}	Supply current	No load (PVDD_x)	Normal mode		32	50	mA
			Reset ($\overline{\text{RESET}} = \text{low}$, PDN = high)		4	8	
$r_{DS(on)}$ ⁽²⁾	Drain-to-source resistance, LS	$T_J = 25^\circ\text{C}$, includes metallization resistance			80		m Ω
	Drain-to-source resistance, HS	$T_J = 25^\circ\text{C}$, includes metallization resistance			80		
I/O PROTECTION							
V_{UVP}	Undervoltage protection limit	PVDD falling			6.4		V
$V_{UVP,hyst}$	Undervoltage protection limit	PVDD rising			7.1		V
OTE ⁽³⁾	Overtemperature error				150		$^\circ\text{C}$
OTE _{HYST} ⁽³⁾	Extra temperature drop required to recover from error				30		$^\circ\text{C}$
I_{OC}	Overcurrent limit protection	Output to output short in BTL mode			4.5		A
I_{OCT}	Overcurrent response time				150		ns

(1) I_{IH} for the PBTL pin has a maximum limit of 200 μA due to an internal pulldown on the pin.

(2) This does not include bond-wire or pin resistance.

(3) Specified by design.

7.7 AC Electrical Characteristics (BTL, PBTL)

PVDD_X = 18 V, BTL AD mode, f_S = 48 kHz, R_L = 8 Ω, C_{BST} = 10 nF, audio frequency = 1 kHz, AES17 filter, f_{PWM} = 384 kHz, T_A = 25°C (unless otherwise noted). All performance is in accordance with recommended operating conditions (unless otherwise noted).

PARAMETER		TEST CONDITIONS	MIN	TYP	MAX	UNIT
P _O	Power output per channel	BTL mode, PVDD = 8 V, R _L = 8 Ω, 7% THD		3.9		W
		BTL mode, PVDD = 8 V, R _L = 8 Ω, 10% THD		4.2		
		BTL mode, PVDD = 12 V, R _L = 8 Ω, 7% THD		8		
		BTL mode, PVDD = 12 V, R _L = 8 Ω, 10% THD		9.6		
		BTL mode, PVDD = 18 V, R _L = 8 Ω, 7% THD		18.7		
		BTL mode, PVDD = 18 V, R _L = 8 Ω, 10% THD		21.2		
		BTL mode, PVDD = 24 V, R _L = 8 Ω, 7% THD		32.6		
		BTL mode, PVDD = 24 V, R _L = 8 Ω, 10% THD		37.2		
		PBTL mode, PVDD = 12 V, R _L = 4 Ω, 7% THD		16.5		
		PBTL mode, PVDD = 12 V, R _L = 4 Ω, 10% THD		17.9		
		PBTL mode, PVDD = 18 V, R _L = 4 Ω, 7% THD		37		
		PBTL mode, PVDD = 18 V, R _L = 4 Ω, 10% THD		39.6		
		PBTL mode, PVDD = 24 V, R _L = 4 Ω, 10% THD		66		
		PBTL mode, PVDD = 24 V, R _L = 4 Ω, 10% THD		69.6		
		SE Mode, PVDD = 12 V, R _L = 4 Ω, 7% THD		4.2		
		SE Mode, PVDD = 12 V, R _L = 4 Ω, 10% THD		4.6		
		SE Mode, PVDD = 18 V, R _L = 4 Ω, 7% THD		9.6		
		SE Mode, PVDD = 18 V, R _L = 4 Ω, 10% THD		10.2		
SE Mode, PVDD = 24 V, R _L = 4 Ω, 7% THD		17.1				
SE Mode, PVDD = 24 V, R _L = 4 Ω, 10% THD		18.1				
THD+N	Total harmonic distortion + noise	PVDD = 8 V, P _O = 1 W		0.15%		
		PVDD = 12 V, P _O = 1 W		0.03%		
		PVDD = 18 V, P _O = 1 W		0.04%		
		PVDD = 24 V, P _O = 1 W		0.1%		
V _n	Output integrated noise (rms)	A-weighted		46		μV
	Cross-talk	P _O = 0.25 W, f = 1 kHz (AD Mode)		-67		dB
SNR	Signal-to-noise ratio ⁽¹⁾	A-weighted, f = 1 kHz, maximum power at THD < 1%		104		dB

(1) SNR is calculated relative to 0-dBFS input level.

7.8 Electrical Characteristics - PLL External Filter Components

PARAMETER		TEST CONDITIONS	MIN	TYP	MAX	UNIT
	External PLL filter capacitor C1	SMD 0603 X7R		47		nF
	External PLL filter capacitor C2	SMD 0603 X7R		4.7		nF
	External PLL filter resistor R	SMD 0603, metal film		470		Ω

7.9 Electrical Characteristic - I²C Serial Control Port Operation

for I²C Interface signals over recommended operating conditions (unless otherwise noted)

PARAMETER		TEST CONDITIONS	MIN	TYP	MAX	UNIT
C _L	Load capacitance for each bus line				400	pF

7.10 Timing Requirements - PLL Input Parameters

PARAMETER		TEST CONDITIONS	MIN	TYP	MAX	UNIT
f_{MCLKI}	MCLK frequency		2.8224		24.576	MHz
	MCLK duty cycle		40%	50%	60%	
$t_r/t_f(MCLK)$	Rise/fall time for MCLK				5	ns
	LRCLK allowable drift before LRCLK reset				4	MCLKs

7.11 Timing Requirements - Serial Audio Ports Slave Mode

over recommended operating conditions (unless otherwise noted)

PARAMETER		TEST CONDITIONS	MIN	TYP	MAX	UNIT
f_{SCLKIN}	Frequency, SCLK $32 \times f_S$, $48 \times f_S$, $64 \times f_S$	$C_L = 30$ pF	1.024		12.288	MHz
t_{su1}	Setup time, LRCLK to SCLK rising edge		10			ns
t_{h1}	Hold time, LRCLK from SCLK rising edge		10			ns
t_{su2}	Setup time, SDIN to SCLK rising edge		10			ns
t_{h2}	Hold time, SDIN from SCLK rising edge		10			ns
	LRCLK frequency		8	48	48	kHz
	SCLK duty cycle		40%	50%	60%	
	LRCLK duty cycle		40%	50%	60%	
	SCLK rising edges between LRCLK rising edges		32		64	SCLK edges
$t_{(edge)}$	LRCLK clock edge with respect to the falling edge of SCLK		-1/4		1/4	SCLK period
t_r/t_f	Rise/fall time for SCLK/LRCLK				8	ns

7.12 Timing Requirements - I²C Serial Control Port Operation

for I²C Interface signals over recommended operating conditions (unless otherwise noted)

PARAMETER		TEST CONDITIONS	MIN	MAX	UNIT
f_{SCL}	Frequency, SCL	No wait states		400	kHz
$t_{w(H)}$	Pulse duration, SCL high		0.6		μ s
$t_{w(L)}$	Pulse duration, SCL low		1.3		μ s
t_r	Rise time, SCL and SDA			300	ns
t_f	Fall time, SCL and SDA			300	ns
t_{su1}	Setup time, SDA to SCL		100		ns
t_{h1}	Hold time, SCL to SDA		0		ns
$t_{(buf)}$	Bus free time between stop and start conditions		1.3		μ s
t_{su2}	Setup time, SCL to start condition		0.6		μ s
t_{h2}	Hold time, start condition to SCL		0.6		μ s
t_{su3}	Setup time, SCL to stop condition		0.6		μ s

7.13 Timing Requirements - Reset (\overline{RESET})

control signal parameters over recommended operating conditions (unless otherwise noted).

PARAMETER		MIN	TYP	MAX	UNIT
$t_{w(RESET)}$	Pulse duration, \overline{RESET} active	100			μ s
$t_{d(I2C_ready)}$	Time to enable I ² C			12	ms

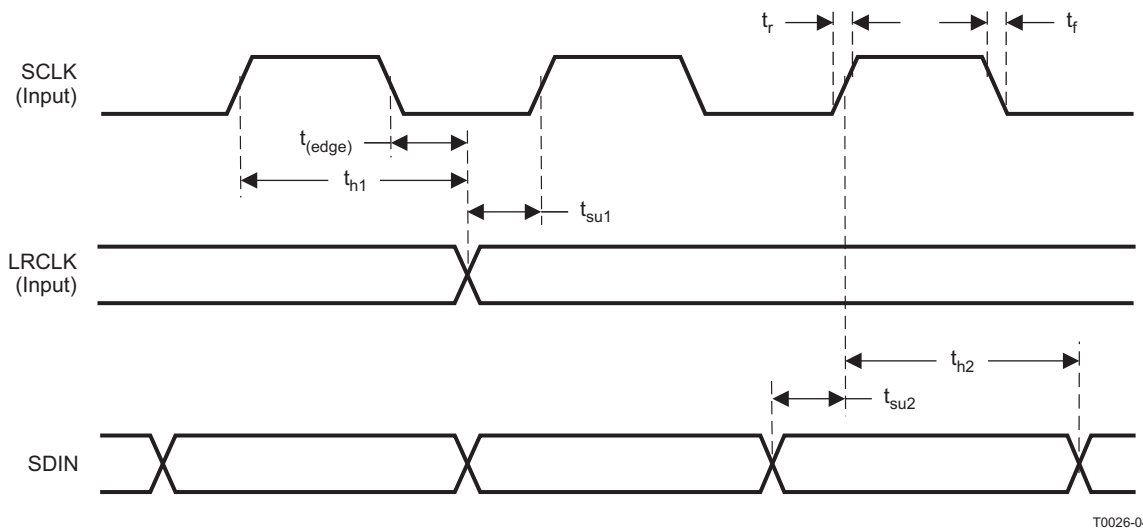

Figure 1. Slave-Mode Serial Data-Interface Timing

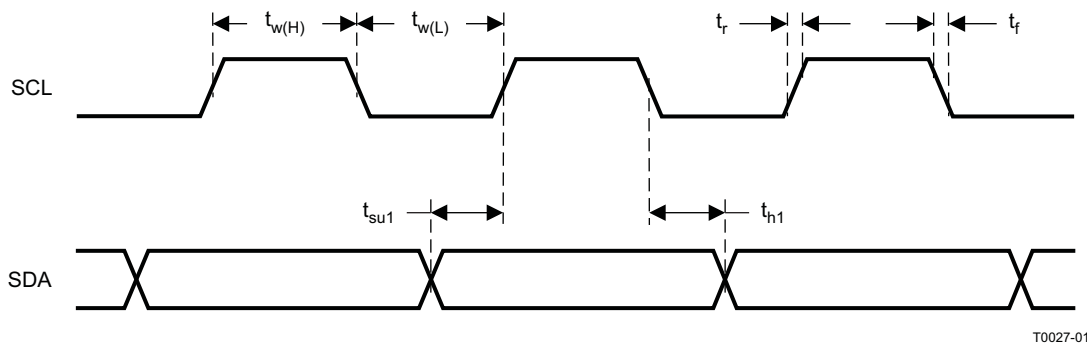

Figure 2. SCL and SDA Timing

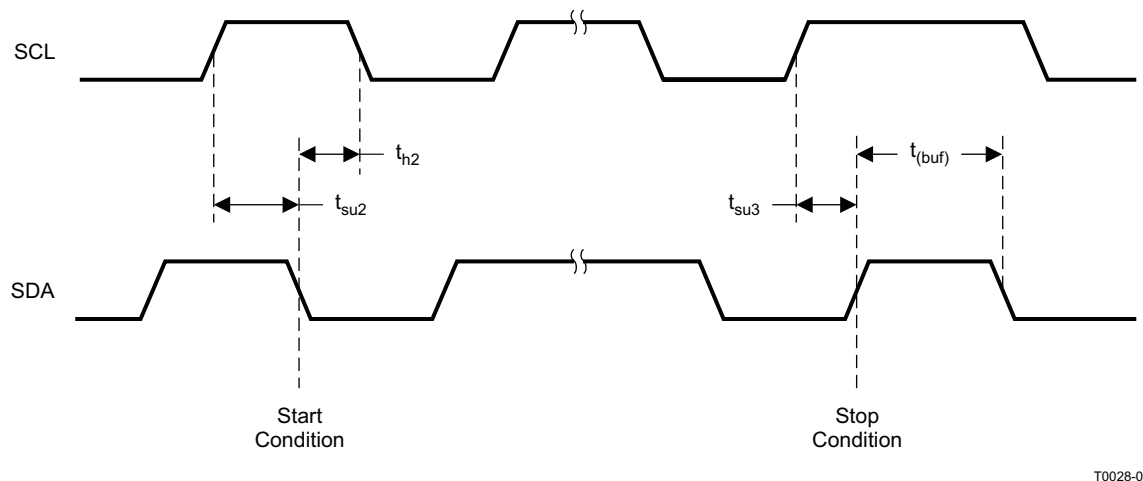
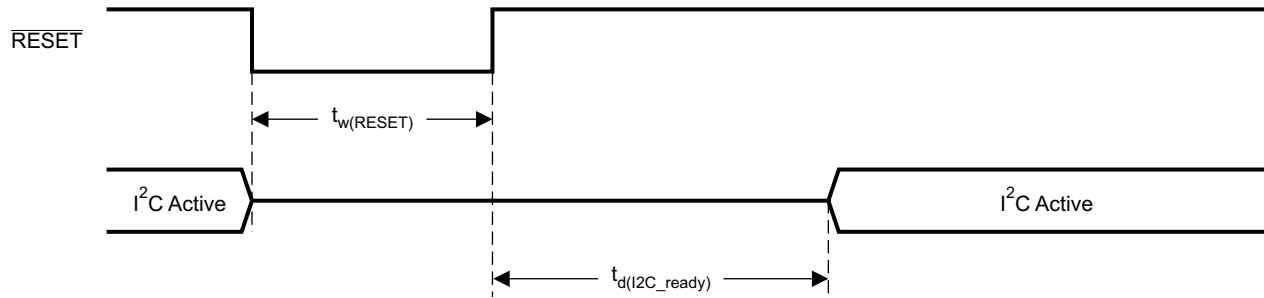

Figure 3. Start and Stop Conditions Timing



System Initialization.

Enable via I²C.

T0421-01

NOTES: On power up, it is recommended that the TAS5731M $\overline{\text{RESET}}$ be held LOW for at least 100 μs after DVDD has reached 3 V.

If $\overline{\text{RESET}}$ is asserted LOW while $\overline{\text{PDN}}$ is LOW, then $\overline{\text{RESET}}$ must continue to be held LOW for at least 100 μs after $\overline{\text{PDN}}$ is deasserted (HIGH).

Figure 4. Reset Timing

7.14 Typical Characteristics

7.14.1 Typical Characteristics, 2.1 SE Configuration, 4 Ω

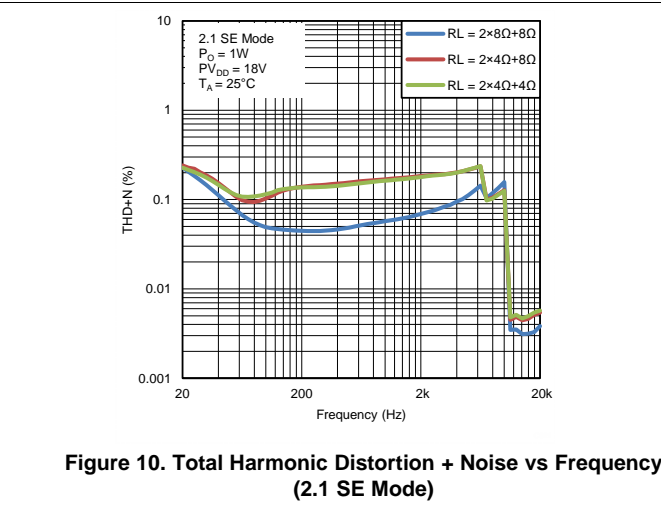
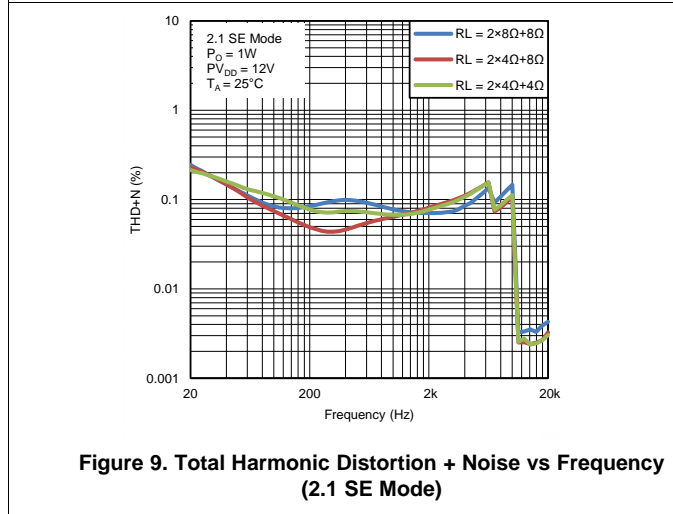
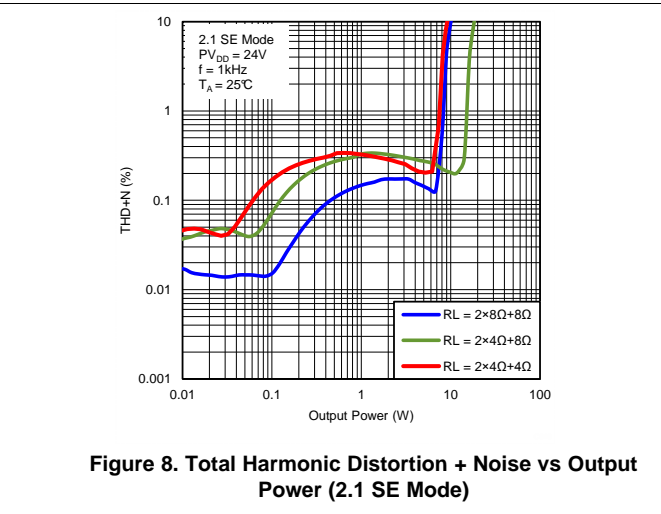
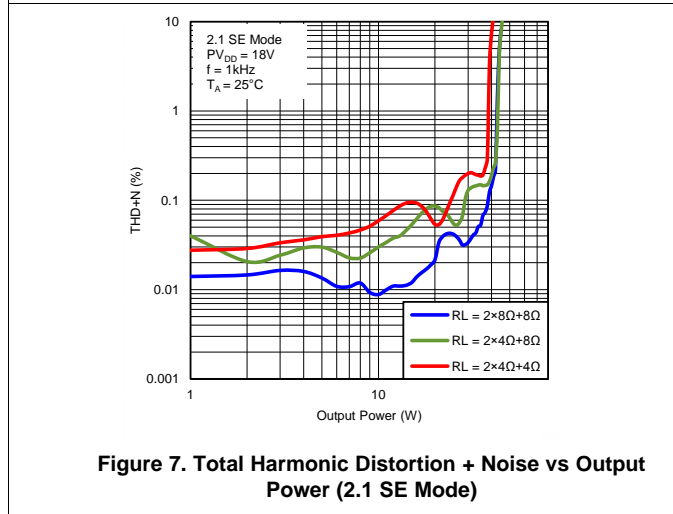
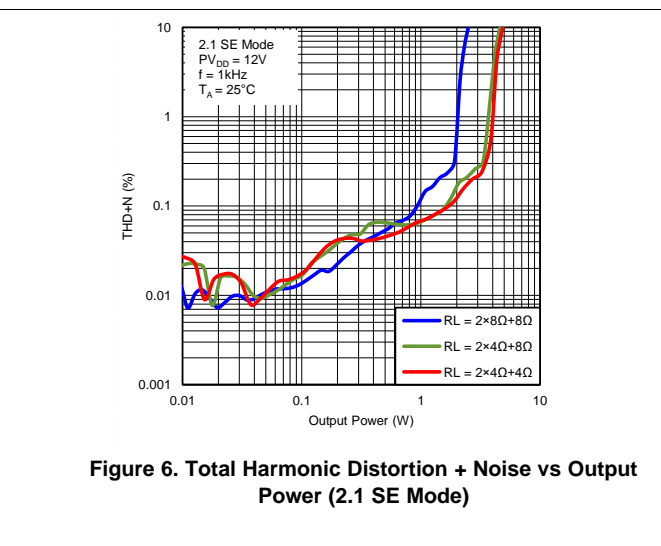
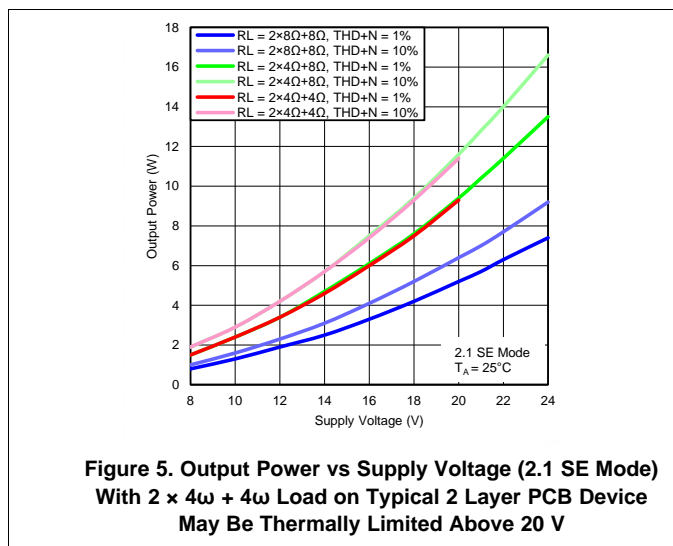

Typical Characteristics, 2.1 SE Configuration, 4 Ω (continued)

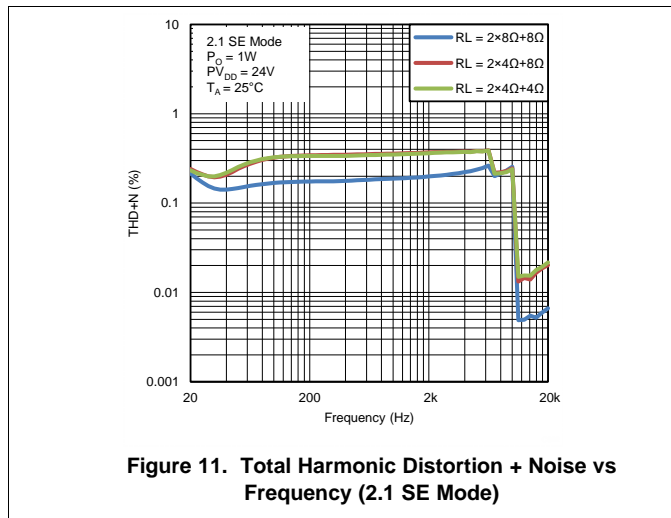

Figure 11. Total Harmonic Distortion + Noise vs Frequency (2.1 SE Mode)

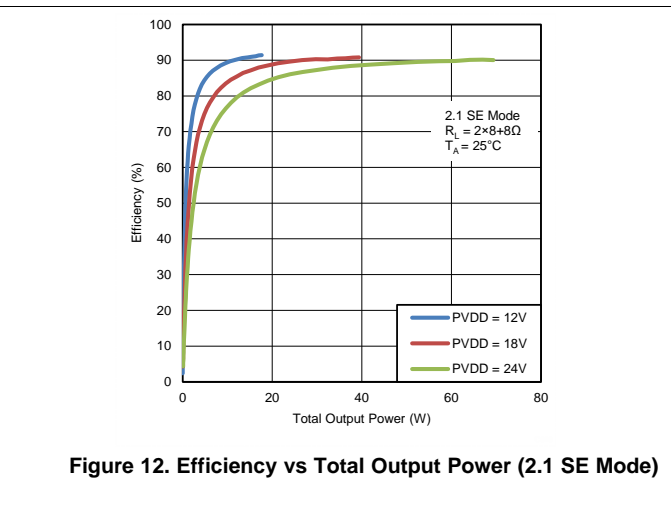

Figure 12. Efficiency vs Total Output Power (2.1 SE Mode)

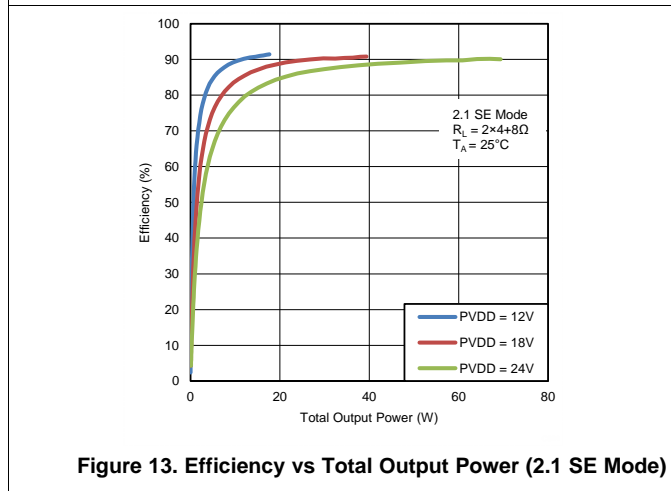

Figure 13. Efficiency vs Total Output Power (2.1 SE Mode)

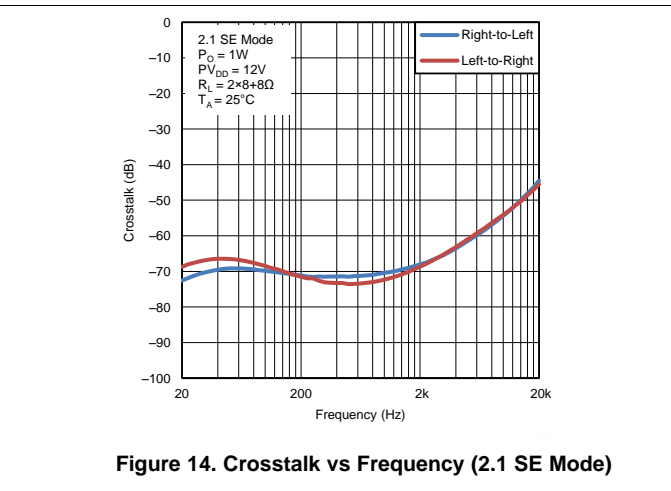

Figure 14. Crosstalk vs Frequency (2.1 SE Mode)

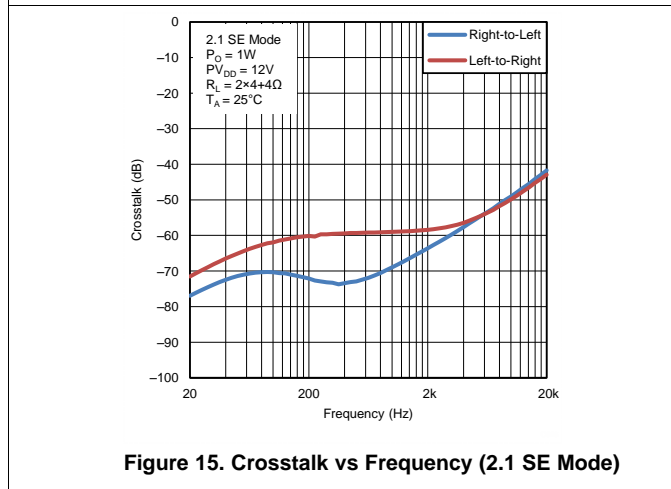

Figure 15. Crosstalk vs Frequency (2.1 SE Mode)

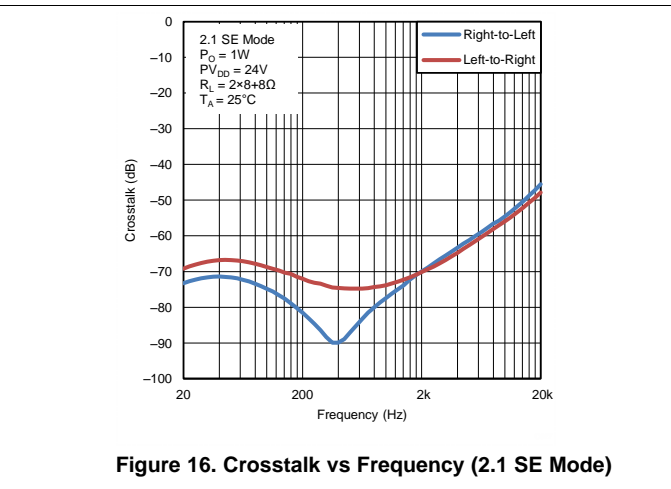

Figure 16. Crosstalk vs Frequency (2.1 SE Mode)

Typical Characteristics, 2.1 SE Configuration, 4 Ω (continued)

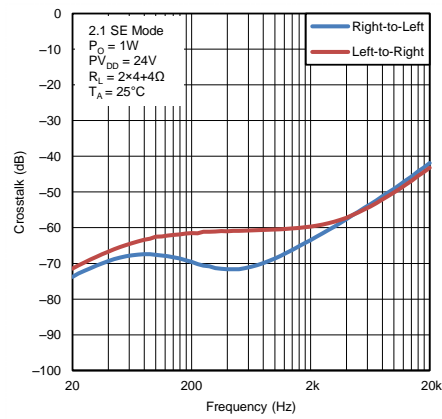

Figure 17. Crosstalk vs Frequency (2.1 SE Mode)

7.14.2 Typical Characteristics, 2.0 BTL Configuration, 8 Ω

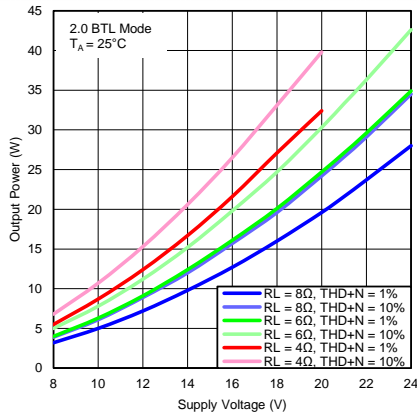

Figure 18. Output Power vs Supply Voltage (2.0 BTL Mode) With 4Ω Load on Typical 2 Layer PCB Device May Be Thermally Limited Above 20 V

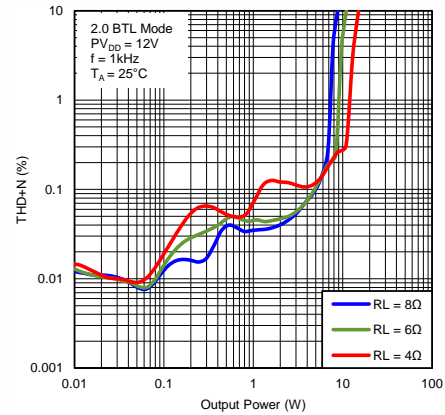

Figure 19. Total Harmonic Distortion + Noise vs Output Power (2.0 BTL Mode)

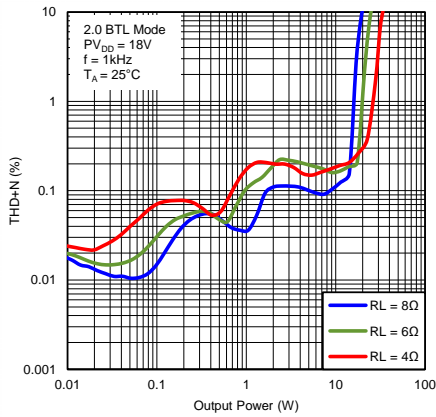

Figure 20. Total Harmonic Distortion + Noise vs Output Power (2.0 BTL Mode)

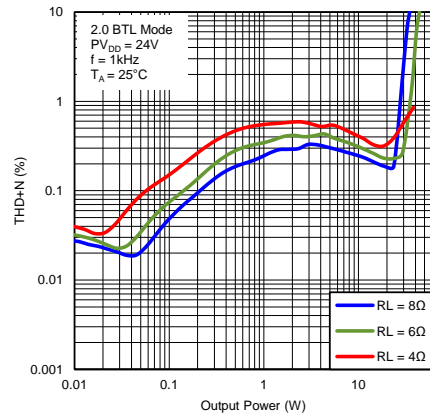

Figure 21. Total Harmonic Distortion + Noise vs Output Power (2.0 BTL Mode)

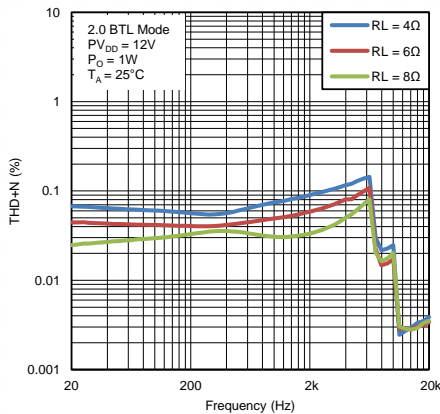

Figure 22. Total Harmonic Distortion vs Frequency (2.0 BTL Mode)

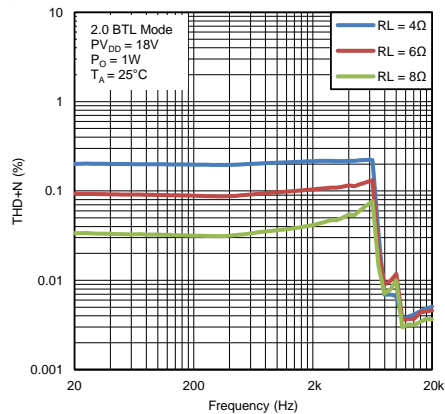

Figure 23. Total Harmonic Distortion vs Frequency (2.0 BTL Mode)

Typical Characteristics, 2.0 BTL Configuration, 8 Ω (continued)

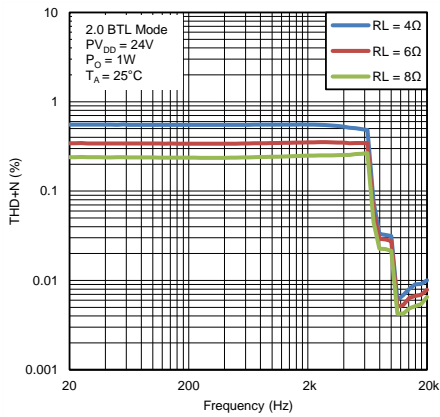

Figure 24. Total Harmonic Distortion vs Frequency (2.0 BTL Mode)

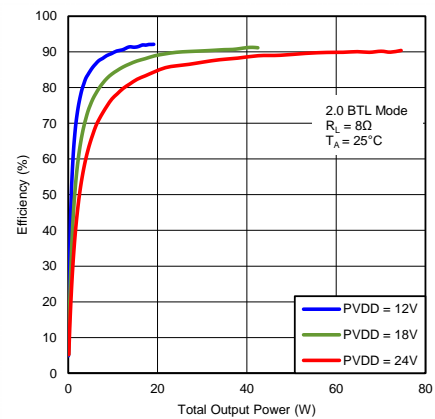

Figure 25. Efficiency vs Output Power (2.0 BTL Mode)

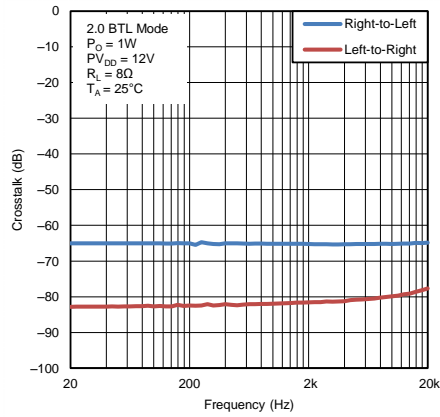

Figure 26. Crosstalk vs Frequency (2.0 BTL Mode)

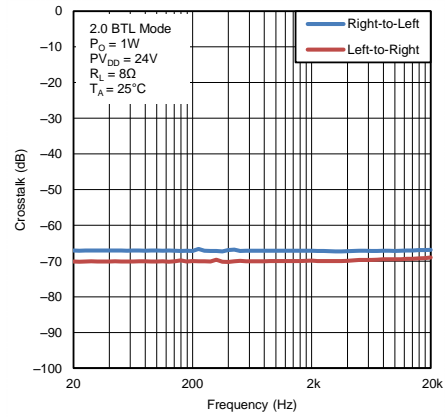

Figure 27. Crosstalk vs Frequency (2.0 BTL Mode)

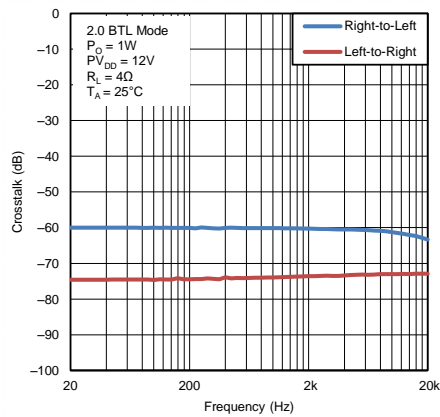

Figure 28. Crosstalk vs Frequency (2.0 BTL Mode)

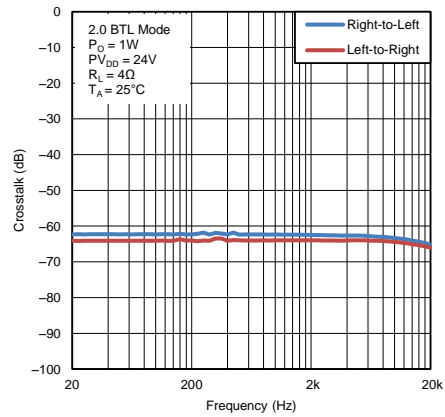

Figure 29. Crosstalk vs Frequency (2.0 BTL Mode)

Typical Characteristics, 2.0 BTL Configuration, 8 Ω (continued)

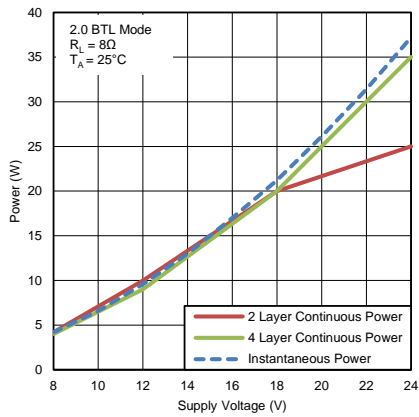

Figure 30. Power vs Supply Voltage (2.0 BTL Mode)

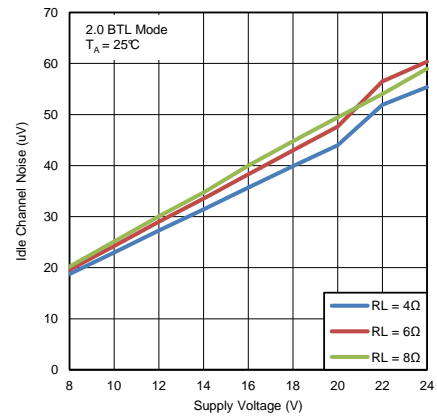

Figure 31. Idle Channel Noise vs Supply Voltage (2.0 BTL Mode)

7.14.3 Typical Characteristics, PBTL Configuration, 8 Ω

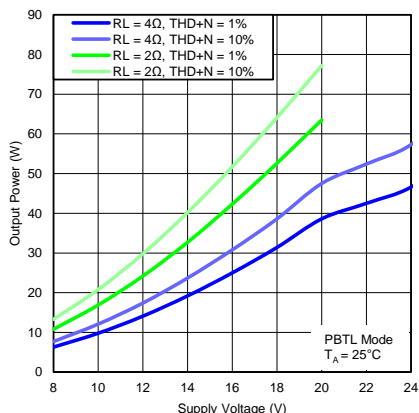

Figure 32. Output Power vs Supply Voltage (PBTL Mode) With 2ω Load on Typical 2 Layer PCB, Device May Be Thermally Limited Above 20 V

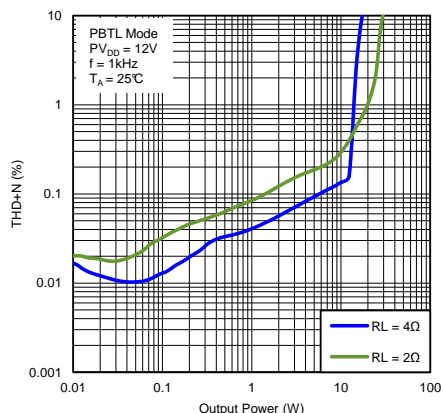

Figure 33. Total Harmonic Distortion + Noise vs Output Power (PBTL Mode)

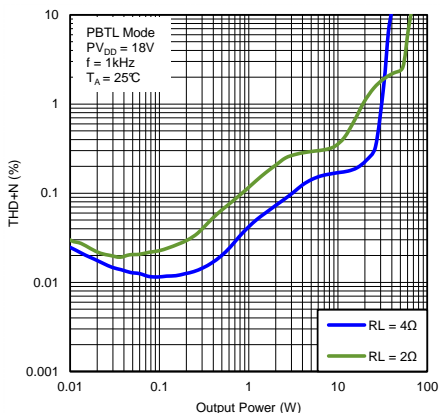

Figure 34. Total Harmonic Distortion + Noise vs Output Power (PBTL Mode)

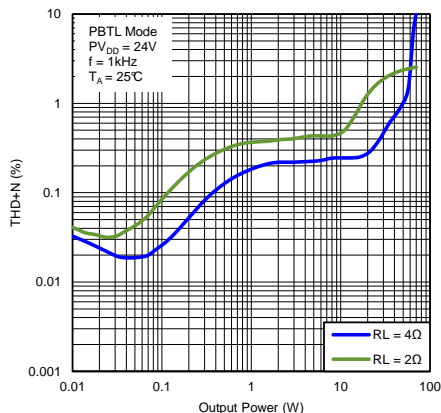

Figure 35. Total Harmonic Distortion + Noise vs Output Power (PBTL Mode)

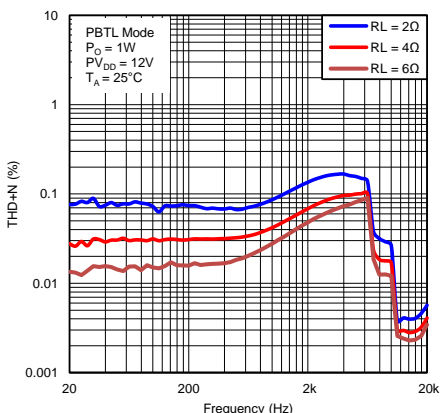

Figure 36. Total Harmonic Distortion vs Frequency (PBTL Mode)

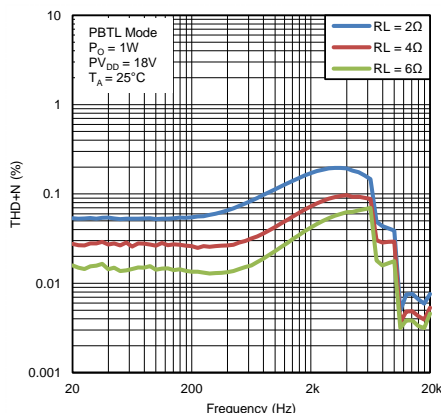

Figure 37. Total Harmonic Distortion vs Frequency (PBTL Mode)

Typical Characteristics, PBTL Configuration, 8 Ω (continued)

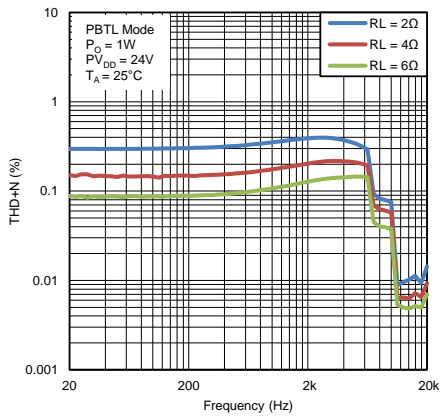

Figure 38. Total Harmonic Distortion vs Frequency (PBTL Mode)

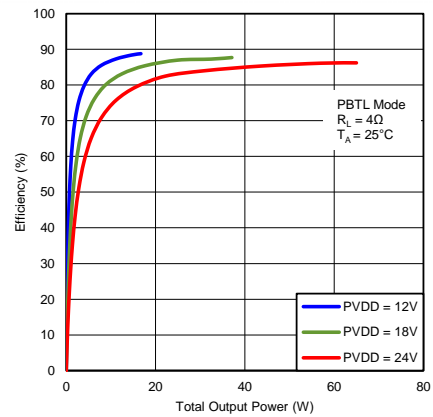

Figure 39. Efficiency vs Output Power (PBTL Mode)

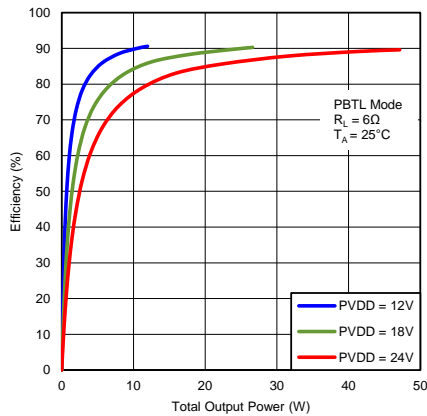

Figure 40. Efficiency vs Output Power (PBTL Mode)

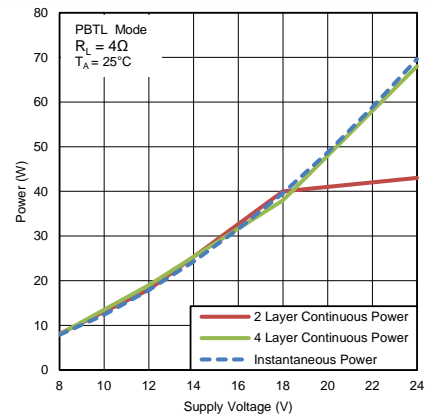

Figure 41. Power vs Supply Voltage (PBTL Mode)

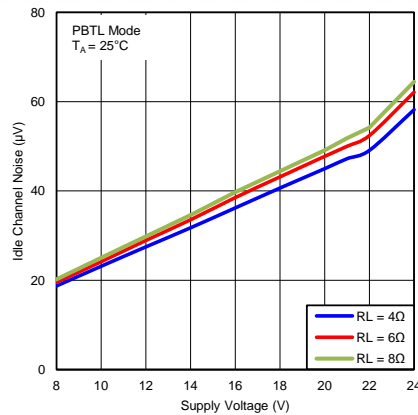

Figure 42. Idle Channel Noise vs Supply Voltage (PBTL Mode)

8 Parameter Measurement Information

All parameters are measured according to the conditions described in the [Specifications](#) section.

9 Detailed Description

9.1 Overview

The TAS5731M is an efficient 30-W stereo I²S input Class-D audio power amplifier. The digital auto processor of the device uses noise shaping and customized correction algorithms to achieve a great power efficiency and high audio performance. Also, the device has up to eight Equalizers per channel and two-band configurable Dynamic Range Control (DRC).

The device needs only a single DVDD supply in addition to the higher-voltage PVDD power supply. An internal voltage regulator provides suitable voltage levels for the gate drive circuit. The wide PVDD power supply range of the device enables its use in a multitude of applications.

The TAS5731M is a slave-only device that is controlled by a bidirectional I²C interface that supports both 100-kHz and 400-kHz data transfer rates for single- and multiple-byte write and read operations. This control interface is used to program the registers of the device and read the device status.

The PWM of this device operates with a carrier frequency between 384 kHz and 354 kHz, depending on the sampling rate. This device allows the use of the same clock signal for both MCLK and BCLK (64xFs) when using a sampling frequency of 44.1 kHz or 48 kHz.

This device can be used in three different modes of operation, Stereo BTL mode, Single filter PBTL mono mode, and 2.1 mode.

9.2 Functional Block Diagrams

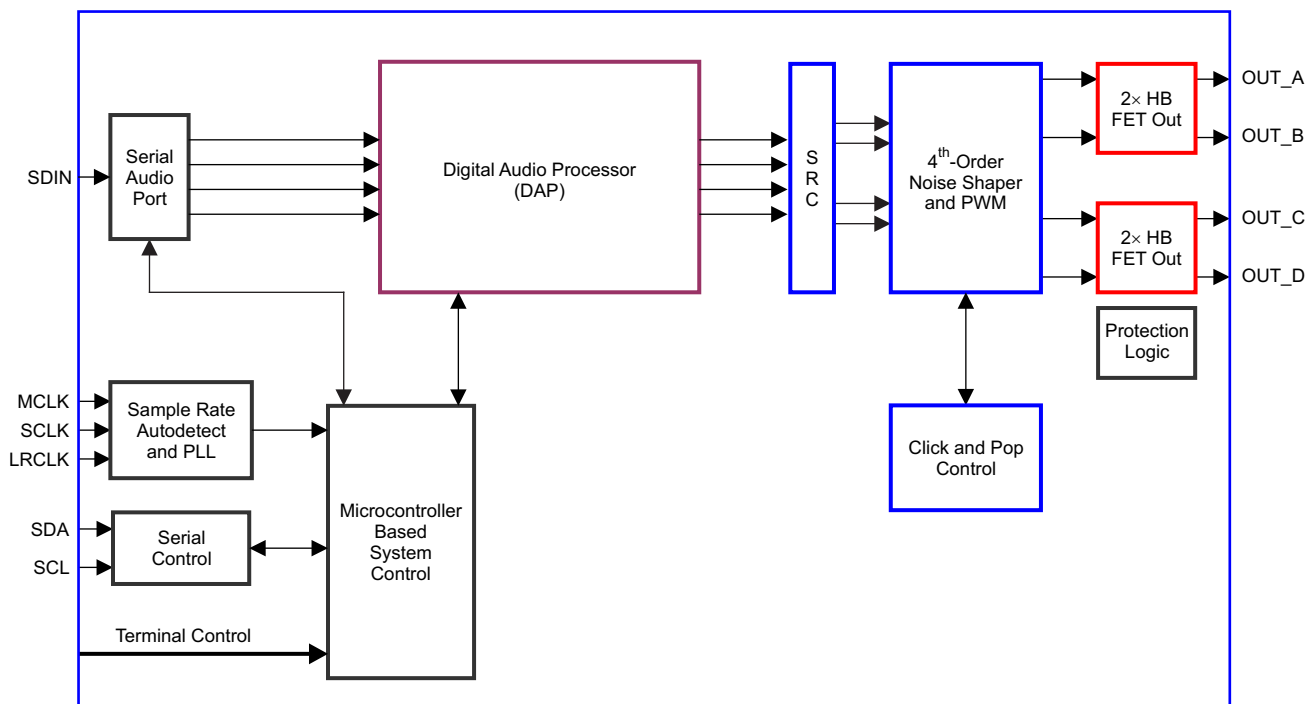

B0262-14

Figure 43. Functional Block Diagram

Functional Block Diagrams (continued)

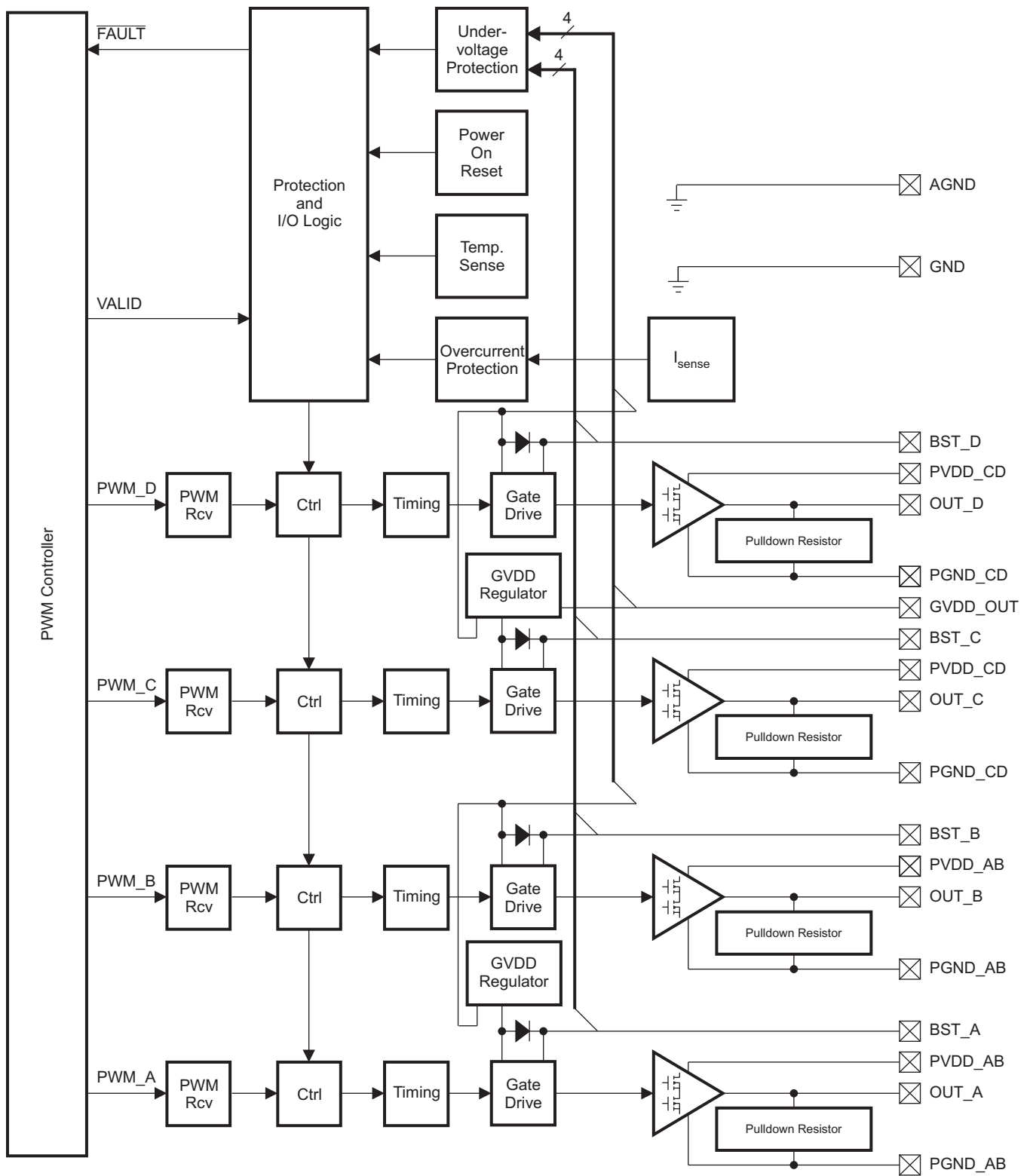

B0034-08

Figure 44. Power-Stage Functional Block Diagram

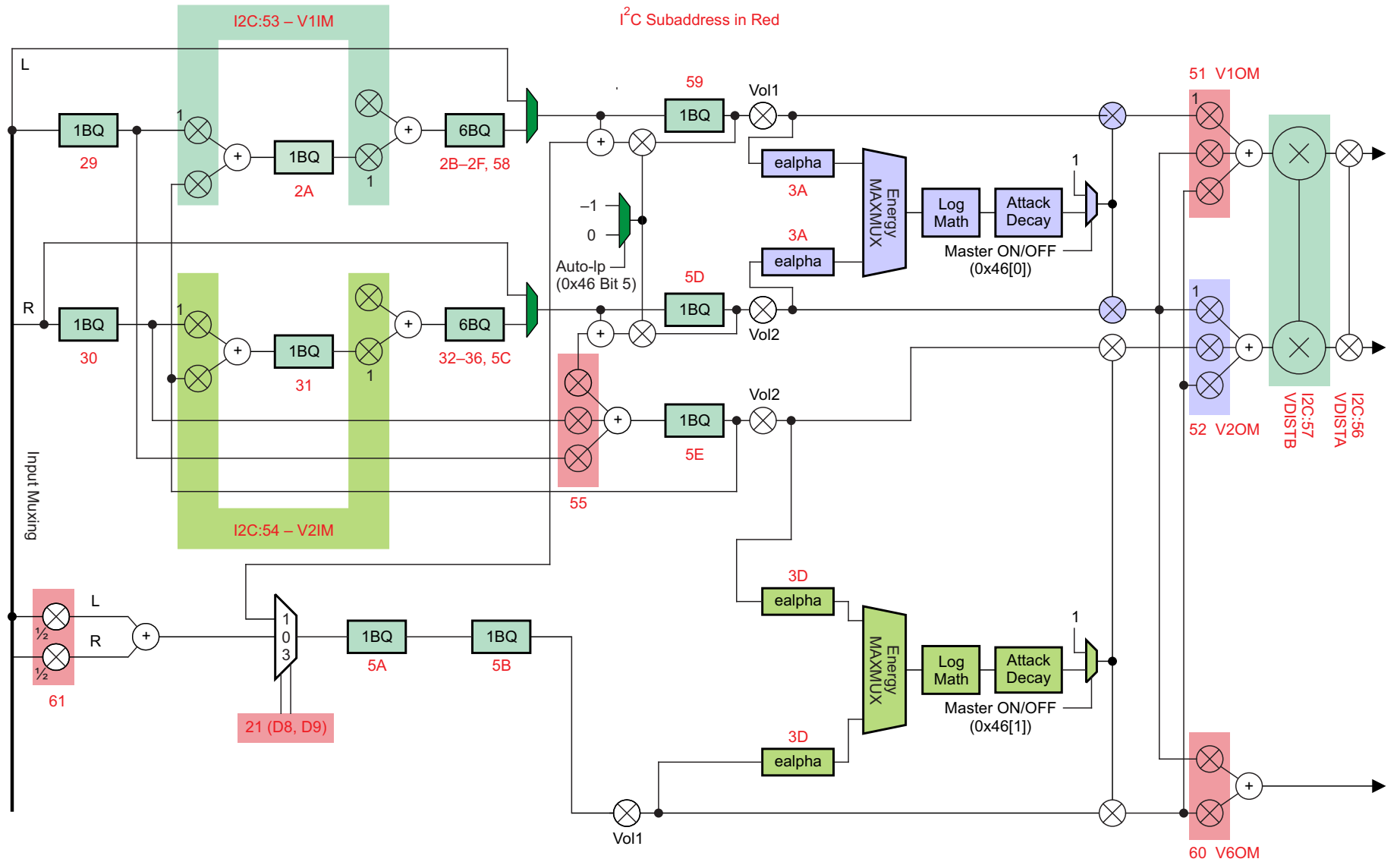

Figure 45. DAP Process Structure

B0321-14

9.3 Feature Description

9.3.1 Power Supply

To facilitate system design, the TAS5731M needs only a 3.3-V supply in addition to the PVDD power-stage supply. An internal voltage regulator provides suitable voltage levels for the gate drive circuitry. Additionally, all circuitry requiring a floating voltage supply, for example, the high-side gate drive, is accommodated by built-in bootstrap circuitry requiring only a few external capacitors.

In order to provide good electrical and acoustical characteristics, the PWM signal path for the output stage is designed as identical half-bridges with separate bootstrap pins (BST_x). The gate-drive voltage (GVDD_OUT) is derived from the PVDD voltage. Special attention must be paid to placing all decoupling capacitors as close to their associated pins as possible. Inductance between the power-supply pins and decoupling capacitors must be avoided.

For a properly functioning bootstrap circuit, a small ceramic capacitor must be connected from each bootstrap pin (BST_x) to the power-stage output pin (OUT_x). When the power-stage output is low, the bootstrap capacitor is charged through an internal diode connected between the gate-drive regulator output pin (GVDD_OUT) and the bootstrap pin. When the power-stage output is high, the bootstrap capacitor potential is shifted above the output potential and thus provides a suitable voltage supply for the high-side gate driver. In an application with PWM switching frequencies in the range from 288 kHz to 384 kHz, it is recommended to use 10-nF, X7R ceramic capacitors, size 0603 or 0805, for the bootstrap supply. These 10-nF capacitors ensure sufficient energy storage, even during minimal PWM duty cycles, to keep the high-side power-stage FET (LDMOS) fully turned on during the remaining part of the PWM cycle.

Special attention must be paid to the power-stage power supply; this includes component selection, PCB placement, and routing. As indicated, each half-bridge has independent power-stage supply pins (PVDD_x). For optimal electrical performance, EMI compliance, and system reliability, it is important that each PVDD_x pin is decoupled with a 100-nF, X7R ceramic capacitor placed as close as possible to each supply pin.

The TAS5731M is fully protected against erroneous power-stage turnon due to parasitic gate charging.

9.3.2 I²C Address Selection and Fault Output

ADR/FAULT is an input pin during power up. It can be pulled HIGH or LOW through a resistor as shown in the [Typical Applications](#) sections in order to set the I²C address. Pulling this pin HIGH through the resistor results in setting the I²C 7-bit address to 0011011 (0x36), and pulling it LOW through the resistor results in setting the address to 0011010 (0x34).

During power up, the address of the device is latched in, freeing up the ADR/FAULT pin to be used as a fault notification output. When configured as a fault output, the pin will go low when a fault occurs and will return to its default state when register 0x02 is cleared. The behavior of the pin in response to a fault condition is to be pulled low immediately upon an error. The device then waits for a period of time determined by BKND_ERR Register (0x1C) before attempting to resume playback. If the error has been cleared when the device attempts to resume playback, playback will resume, the ADR/FAULT pin will remain high, and normal operation will resume. If the error has not been removed, then the device will immediately re-enter the protected state and wait again for the predetermined period of time to pass. The device will pull the fault pin low for over-current, over-temperature, and under-voltage lock-out.

9.3.3 Single-Filter PBTL Mode

The TAS5731M supports parallel BTL (PBTL) mode with OUT_A/OUT_B (and OUT_C/OUT_D) connected before the LC filter. In addition to connecting OUT_A/OUT_B and OUT_C/OUT_D, BST_A/BST_B and BST_C/BST_D must also be connected before the LC filter, as shown in the [Figure 71](#). In order to put the part in PBTL configuration, drive PBTL (pin 8) HIGH. This synchronizes the turnoff of half-bridges A and B (and similarly C/D) if an overcurrent condition is detected in either half-bridge. There is a pulldown resistor on the PBTL pin that configures the part in BTL mode if the pin is left floating.

PWM output multiplexers must be updated to set the device in PBTL mode. Output Mux Register (0x25) must be written with a value of 0x0110 3245.

Feature Description (continued)

9.3.4 Device Protection System

9.3.4.1 Overcurrent (OC) Protection With Current Limiting

The device has independent, fast-reacting current detectors on all high-side and low-side power-stage FETs. The detector outputs are closely monitored by a protection system. If the high-current condition situation persists, that is, the power stage is being overloaded, a protection system triggers a latching shutdown, resulting in the power stage being set in the high-impedance (Hi-Z) state. The device returns to normal operation once the fault condition (that is, a short circuit on the output) is removed. Current-limiting and overcurrent protection are not independent for half-bridges. That is, if the bridge-tied load between half-bridges A and B causes an overcurrent fault, half-bridges A, B, C, and D are shut down.

9.3.4.2 Overtemperature Protection

The TAS5731M has an overtemperature-protection system. If the device junction temperature exceeds 150°C (nominal), the device is put into thermal shutdown, resulting in all half-bridge outputs being set in the high-impedance (Hi-Z) state. The TAS5731M recovers automatically once the temperature drops approximately 30°C.

9.3.4.3 Undervoltage Protection (UVP) and Power-On Reset (POR)

The UVP and POR circuits of the TAS5731M fully protect the device in any power-up/down and brownout situation. While powering up, the POR circuit resets the overload circuit (OLP) and ensures that all circuits are fully operational when the PVDD and AVDD supply voltages reach 7.6 V and 2.7 V, respectively. Although PVDD and AVDD are independently monitored, a supply-voltage drop below the UVP threshold on AVDD or either PVDD pin results in all half-bridge outputs immediately being set in the high-impedance (Hi-Z) state.

9.3.5 SSTIMER Functionality

The SSTIMER pin uses a capacitor connected between this pin and ground to control the output duty cycle when exiting all-channel shutdown. The capacitor on the SSTIMER pin is slowly charged through an internal current source, and the charge time determines the rate at which the output transitions from a near-zero duty cycle to the desired duty cycle. This allows for a smooth transition that minimizes audible pops and clicks. When the part is shut down, the drivers are placed in the high-impedance state and transition slowly down through a 3-kΩ resistor, similarly minimizing pops and clicks. The shutdown transition time is independent of the SSTIMER pin capacitance. Larger capacitors increase the start-up time, while capacitors smaller than 2.2 nF decrease the start-up time. The SSTIMER pin can be left floating for BD modulation.

9.3.6 Clock, Autodetection, and PLL

The TAS5731M is an I²S slave device. It accepts MCLK, SCLK, and LRCLK. The digital audio processor (DAP) supports all the sample rates and MCLK rates that are defined in the [Clock Control Register \(0x00\)](#).

The TAS5731M checks to verify that SCLK is a specific value of 32 f_s, 48 f_s, or 64 f_s. The DAP only supports a 1 × f_s LRCLK. The timing relationship of these clocks to SDIN is shown in subsequent sections. The clock section uses MCLK or the internal oscillator clock (when MCLK is unstable, out of range, or absent) to produce the internal clock (DCLK) running at 512 times the PWM switching frequency.

The DAP can autodetect and set the internal clock control logic to the appropriate settings for all supported clock rates as defined in the clock-control register.

The TAS5731M has robust clock error handling that uses the built-in trimmed oscillator clock to quickly detect changes/errors. Once the system detects a clock change/error, it mutes the audio (through a single-step mute) and then forces PLL to limp using the internal oscillator as a reference clock. Once the clocks are stable, the system autodetects the new rate and reverts to normal operation. During this process, the default volume is restored in a single step (also called hard unmute). The ramp process can be programmed to ramp back slowly (also called soft unmute) as defined in volume register (0x0E).

Feature Description (continued)

9.3.7 PWM Section

The TAS5731M DAP device uses noise-shaping and customized nonlinear correction algorithms to achieve high power efficiency and high-performance digital audio reproduction. The DAP uses a fourth-order noise shaper to increase dynamic range and SNR in the audio band. The PWM section accepts 24-bit PCM data from the DAP and outputs two BTL PWM audio output channels.

The PWM section has individual-channel dc-blocking filters that can be enabled and disabled. The filter cutoff frequency is less than 1 Hz. Individual-channel de-emphasis filters for 44.1 kHz and 48 kHz are included and can be enabled and disabled.

Finally, the PWM section has an adjustable maximum modulation limit of 93.8% to 99.2%.

For a detailed description of using audio processing features like DRC and EQ, see the *TAS5731 EVM User's Guide* ([SLOU331](#)) and *TAS570X GDE Software Setup* development tool documentation ([SLOC124](#)).

9.3.8 2.1-Mode Support

The TAS5731 uses a special mid-Z ramp sequence to reduce click and pop in SE-mode and 2.1-mode operation. To enable the mid-Z ramp, register 0x05 bit D7 must be set to 1. To enable 2.1 mode, register 0x05 bit D2 must be set to 1. The SSTIMER pin must be left floating in this mode.

9.3.9 I²C Compatible Serial Control Interface

The TAS5731M DAP has an I²C serial control slave interface to receive commands from a system controller. The serial control interface supports both normal-speed (100 kHz) and high-speed (400 kHz) operations without wait states. As an added feature, this interface operates even if MCLK is absent. The serial control interface supports both single-byte and multiple-byte read and write operations for status registers and the general control registers associated with the PWM.

9.3.10 Audio Serial Interface

Serial data is input on SDIN. The PWM outputs are derived from SDIN. The TAS5731M DAP accepts serial data in 16-, 20-, or 24-bit left-justified, right-justified, and I²S serial data formats.

9.3.10.1 I²S Timing

I²S timing uses LRCLK to define when the data being transmitted is for the left channel and when it is for the right channel. LRCLK is low for the left channel and high for the right channel. A bit clock running at 32, 48, or $64 \times f_s$ is used to clock in the data. There is a delay of one bit clock from the time the LRCLK signal changes state to the first bit of data on the data lines. The data is written MSB-first and is valid on the rising edge of bit clock. The DAP masks unused trailing data bit positions.

Feature Description (continued)

2-Channel I²S (Philips Format) Stereo Input

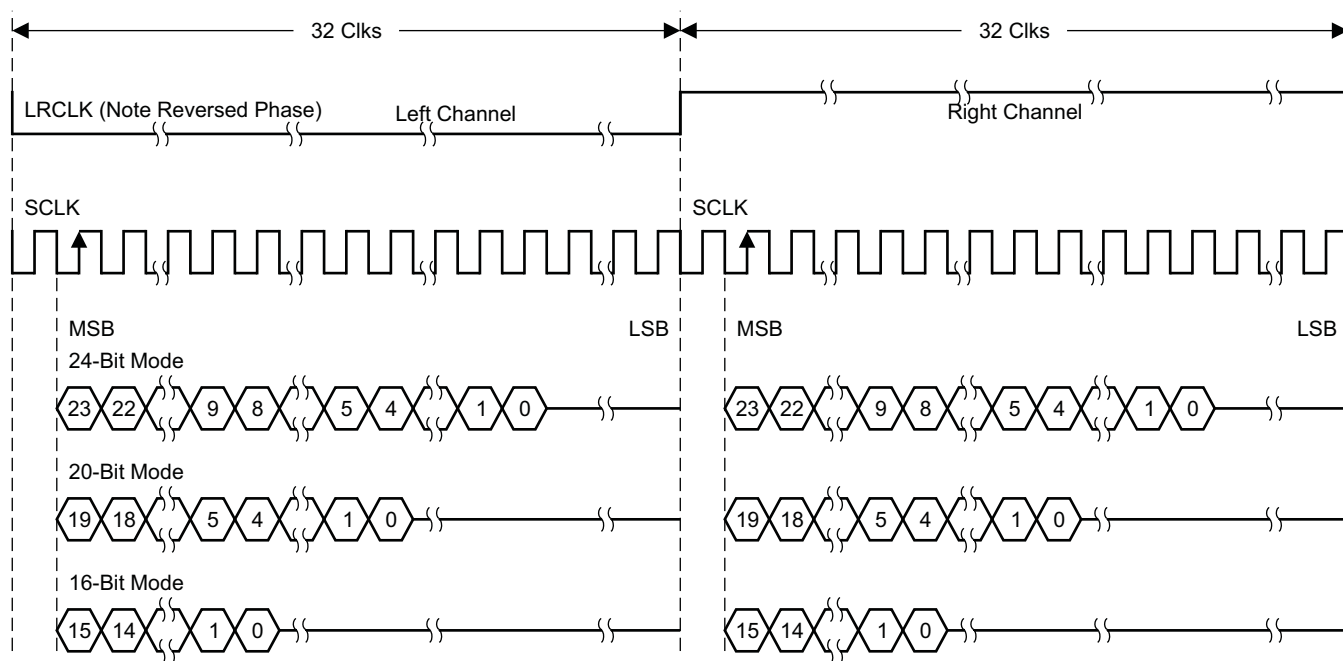

T0034-01

NOTE: All data presented in 2s-complement form with MSB first.

Figure 46. I²S 64-F_s Format

Feature Description (continued)

2-Channel I²S (Philips Format) Stereo Input/Output (24-Bit Transfer Word Size)

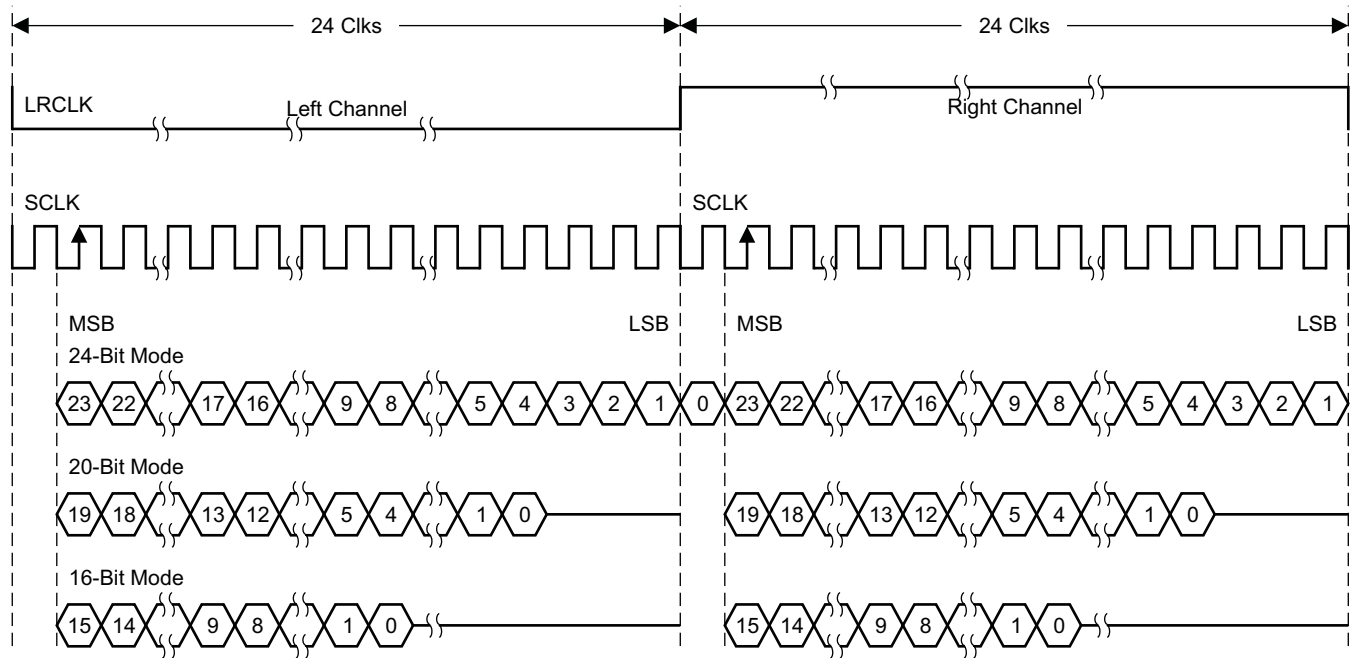

T0092-01

NOTE: All data presented in 2s-complement form with MSB first.

Figure 47. I²S 48-F_s Format

2-Channel I²S (Philips Format) Stereo Input

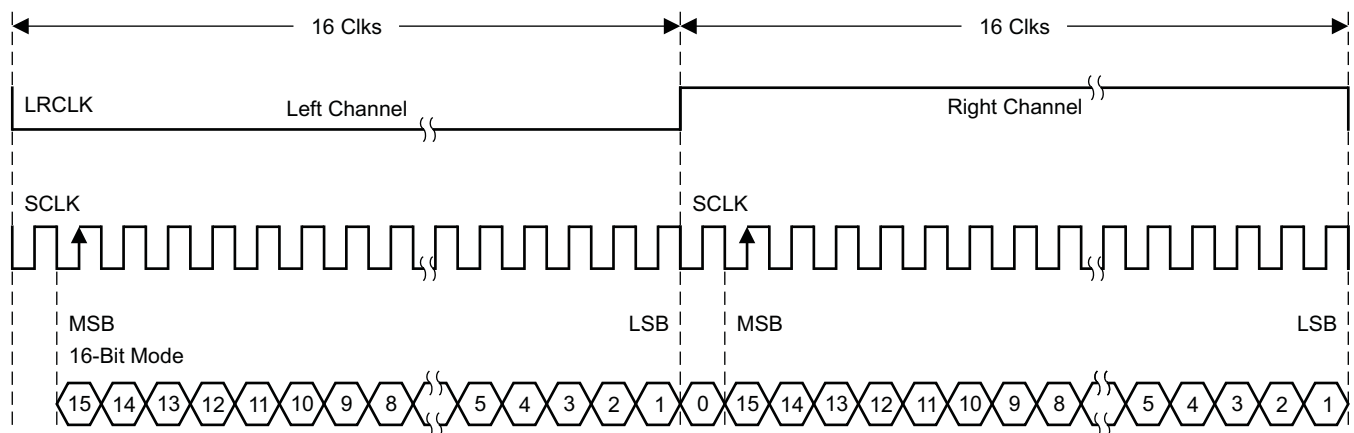

T0266-01

NOTE: All data presented in 2s-complement form with MSB first.

Figure 48. I²S 32-F_s Format

Feature Description (continued)

9.3.10.2 Left-Justified

Left-justified (LJ) timing uses LRCLK to define when the data being transmitted is for the left channel and when it is for the right channel. LRCLK is high for the left channel and low for the right channel. A bit clock running at $32, 48, \text{ or } 64 \times f_s$ is used to clock in the data. The first bit of data appears on the data lines at the same time LRCLK toggles. The data is written MSB-first and is valid on the rising edge of the bit clock. The DAP masks unused trailing data bit positions.

2-Channel Left-Justified Stereo Input

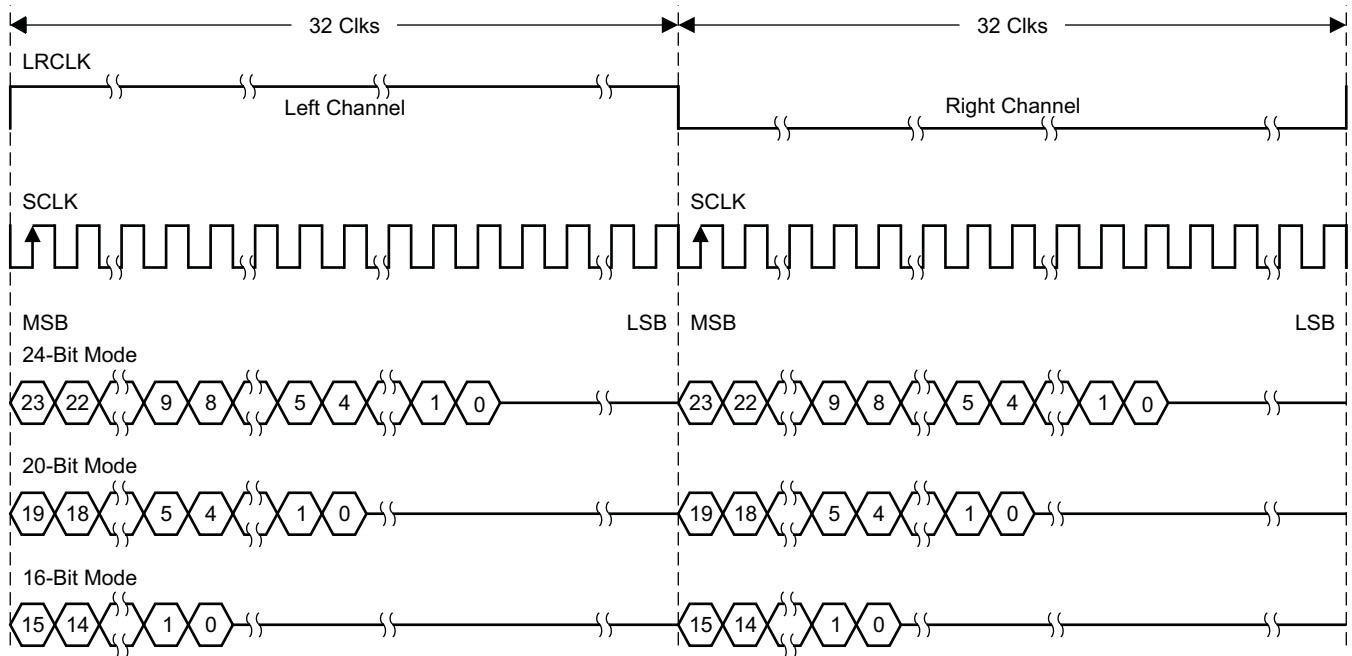

T0034-02

NOTE: All data presented in 2s-complement form with MSB first.

Figure 49. Left-Justified 64-F_s Format

Feature Description (continued)

2-Channel Left-Justified Stereo Input (24-Bit Transfer Word Size)

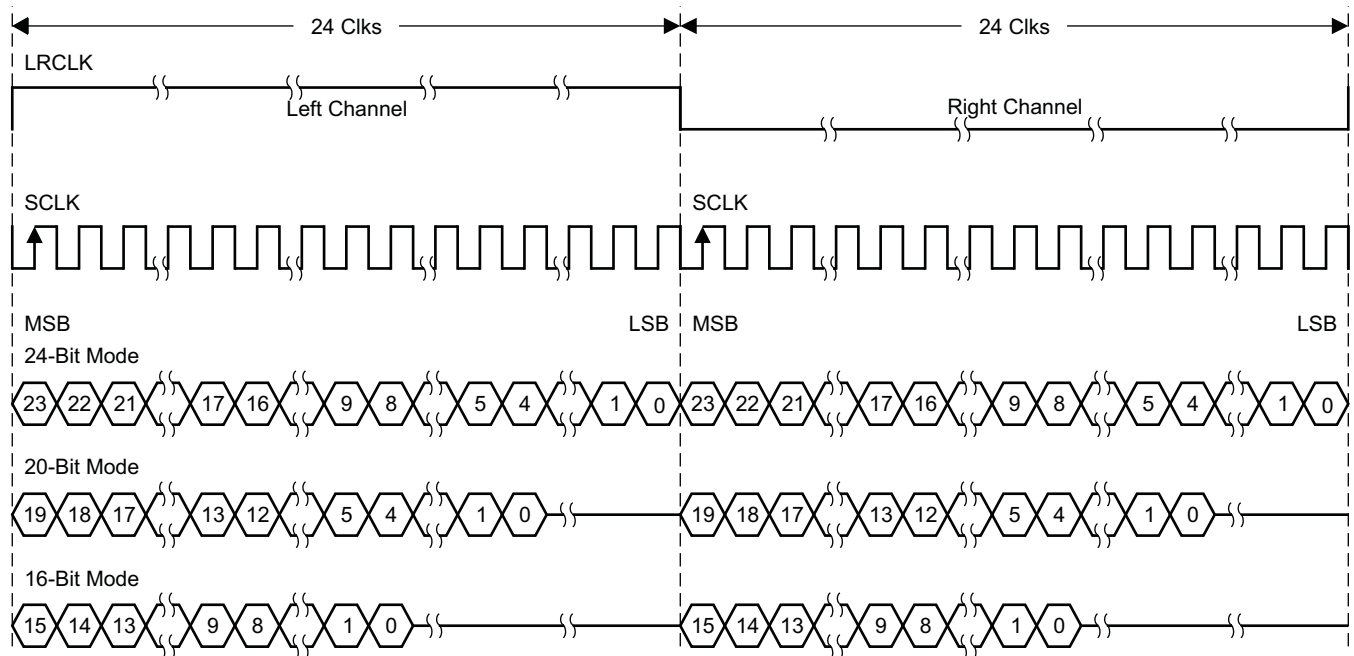

T0092-02

NOTE: All data presented in 2s-complement form with MSB first.

Figure 50. Left-Justified 48-F_s Format

2-Channel Left-Justified Stereo Input

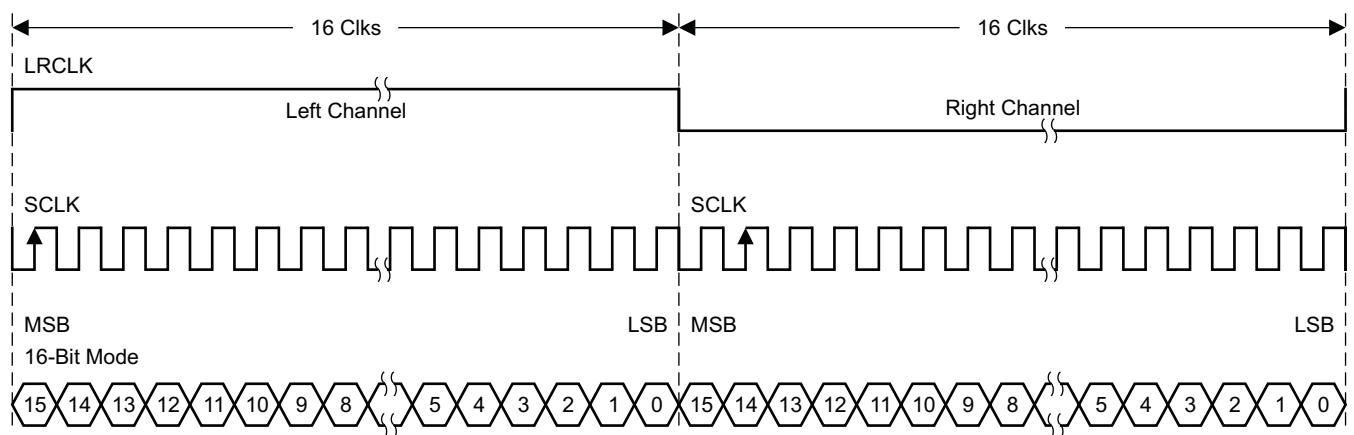

T0266-02

NOTE: All data presented in 2s-complement form with MSB first.

Figure 51. Left-Justified 32-F_s Format

Feature Description (continued)

9.3.10.3 Right-Justified

Right-justified (RJ) timing uses LRCLK to define when the data being transmitted is for the left channel and when it is for the right channel. LRCLK is high for the left channel and low for the right channel. A bit clock running at $32, 48, \text{ or } 64 \times f_s$ is used to clock in the data. The first bit of data appears on the data 8 bit-clock periods (for 24-bit data) after LRCLK toggles. In RJ mode, the LSB of data is always clocked by the last bit clock before LRCLK transitions. The data is written MSB-first and is valid on the rising edge of bit clock. The DAP masks unused leading data bit positions.

2-Channel Right-Justified (Sony Format) Stereo Input

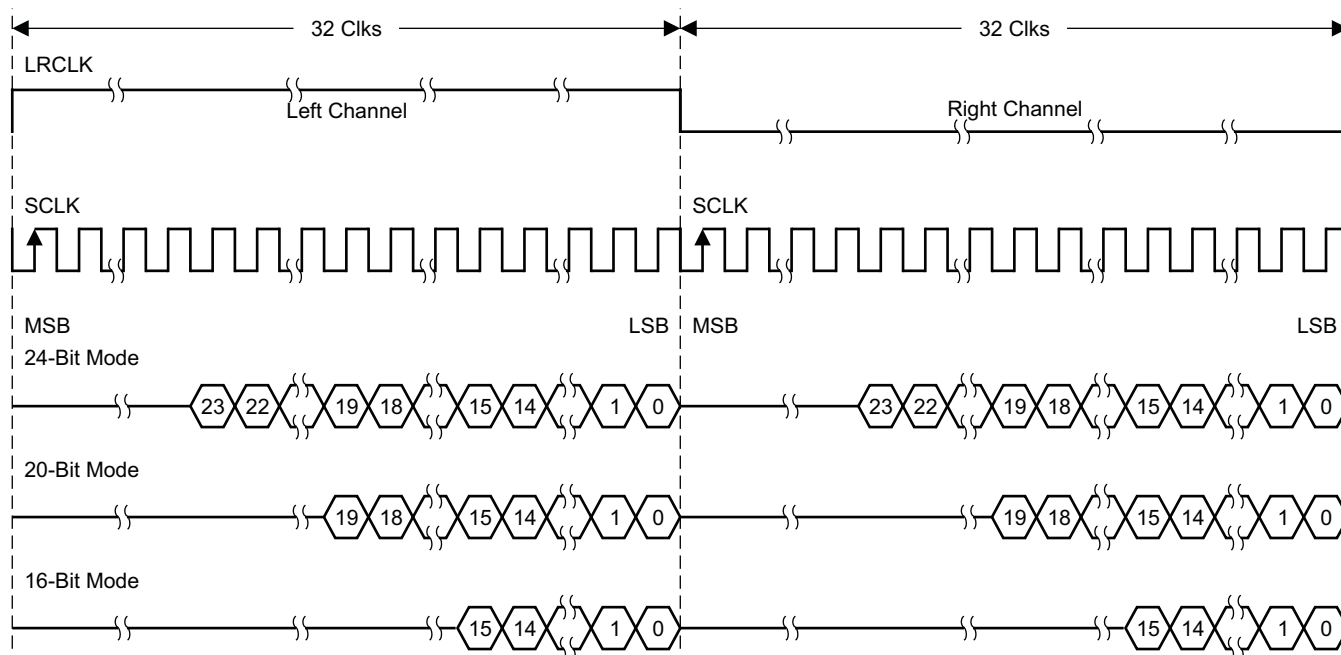

T0034-03

Figure 52. Right-Justified 64- F_s Format

Feature Description (continued)

2-Channel Right-Justified Stereo Input (24-Bit Transfer Word Size)

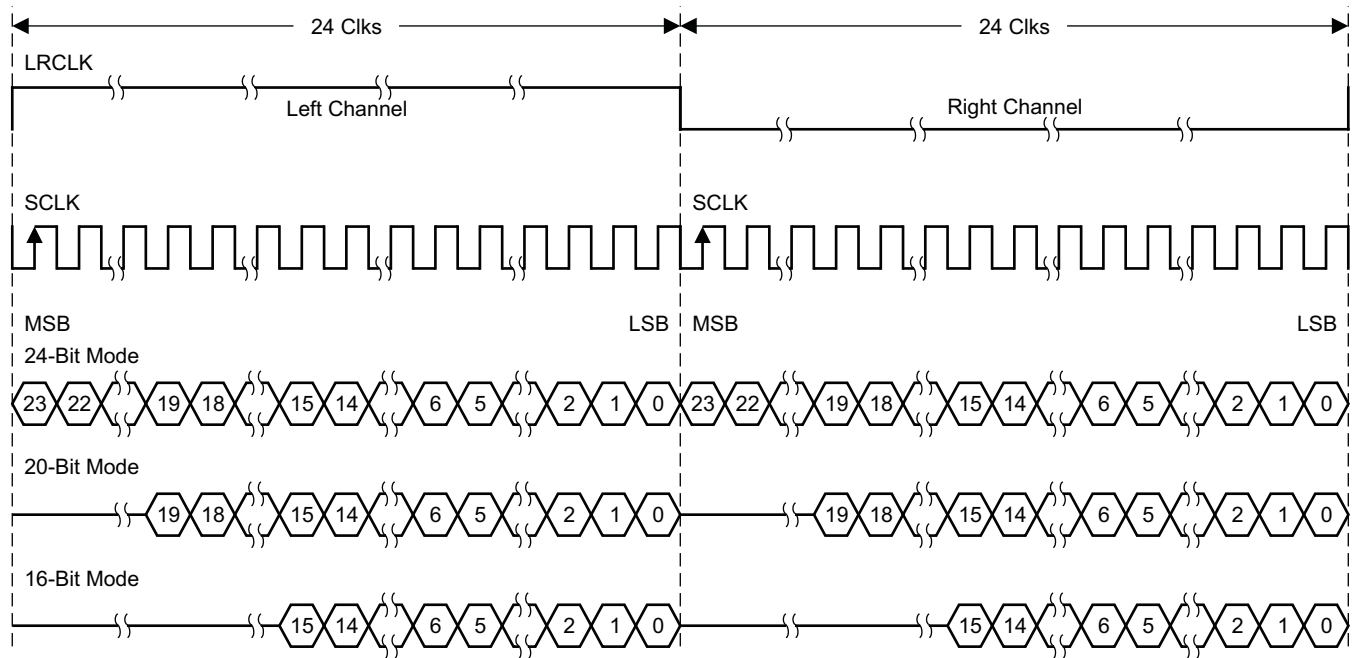

T0092-03

Figure 53. Right-Justified 48-F_s Format

2-Channel Right-Justified (Sony Format) Stereo Input

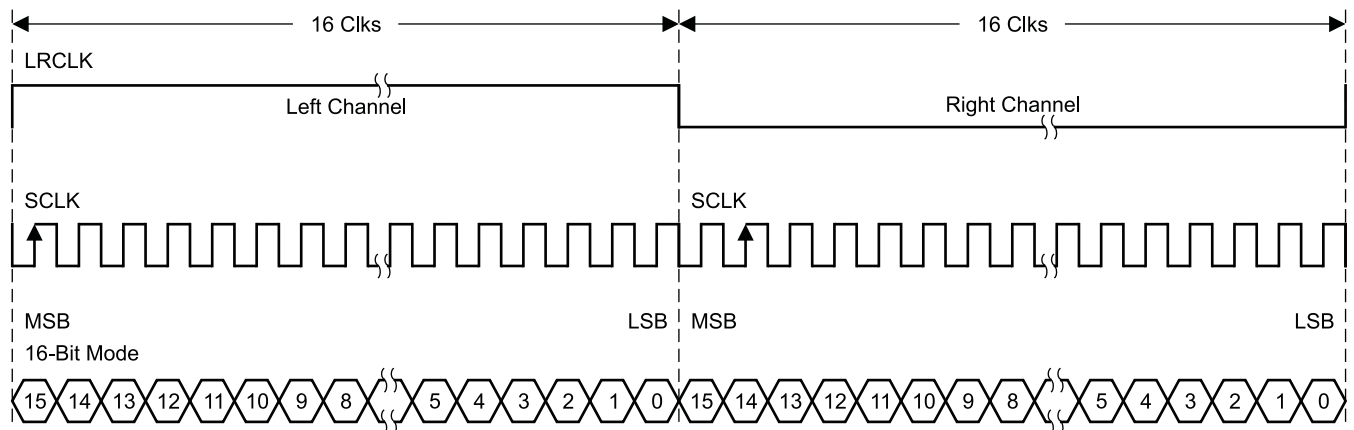

T0266-03

Figure 54. Right-Justified 32-F_s Format

Feature Description (continued)

9.3.11 Dynamic Range Control (DRC)

The DRC scheme has two DRC blocks. There is one ganged DRC for the high-band left/right channels and one DRC for the low-band left/right channels.

The DRC input/output diagram is shown in Figure 55.

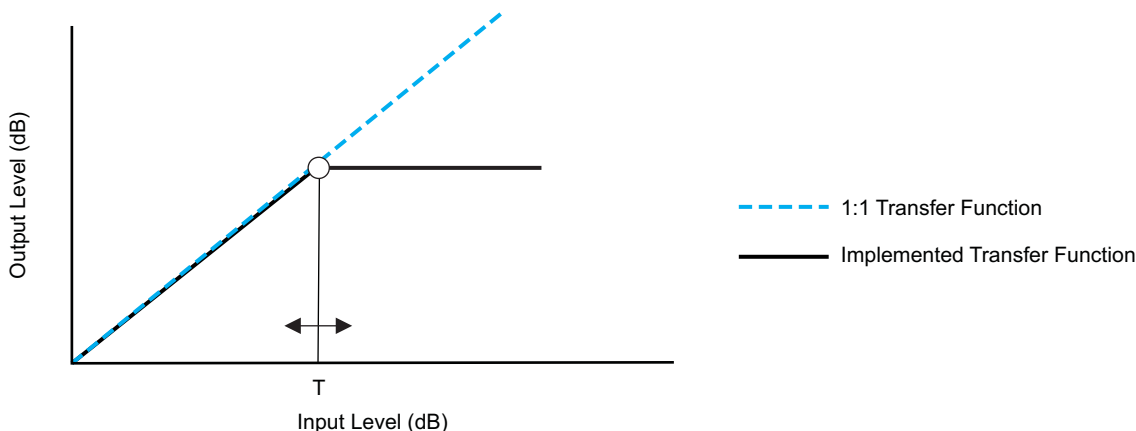

M0091-04

Professional-quality dynamic range compression automatically adjusts volume to flatten volume level.

- Each DRC has adjustable threshold levels.
- Programmable attack and decay time constants
- *Transparent compression*: compressors can attack fast enough to avoid apparent clipping before engaging, and decay times can be set slow enough to avoid pumping.

Figure 55. Dynamic Range Control

	α, ω	T	$\alpha_a, \omega_a / \alpha_d, \omega_d$
DRC1	0x3C	0x3B	0x40
DRC2	0x3F	0x3E	0x43

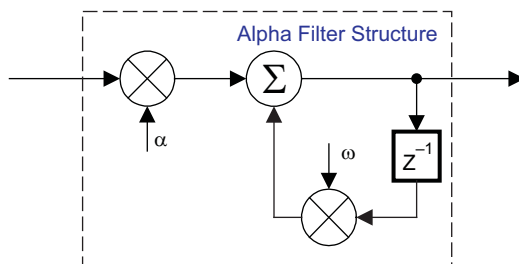

B0265-04

T = 9.23 format, all other DRC coefficients are 3.23 format

Figure 56. DRC Structure

9.4 Device Functional Modes

9.4.1 Stereo BTL Mode

The classic stereo mode of operation uses the TAS5731M device to amplify two independent signals, which represent the left and right portions of a stereo signal. These amplified left and right audio signals are presented on differential output pairs shown as OUT_A and OUT_B for a channel and OUT_C and OUT_D for the other one. The routing of the audio data which is presented on the OUT_x outputs can be changed according to the PWM Output Mux Register (0x25). By default, the TAS5731M device is configured to output channel 1 to the OUT_A and OUT_B outputs, and channel 2 to the OUT_C and OUT_D outputs. Stereo Mode operation outputs are shown in [Figure 57](#).

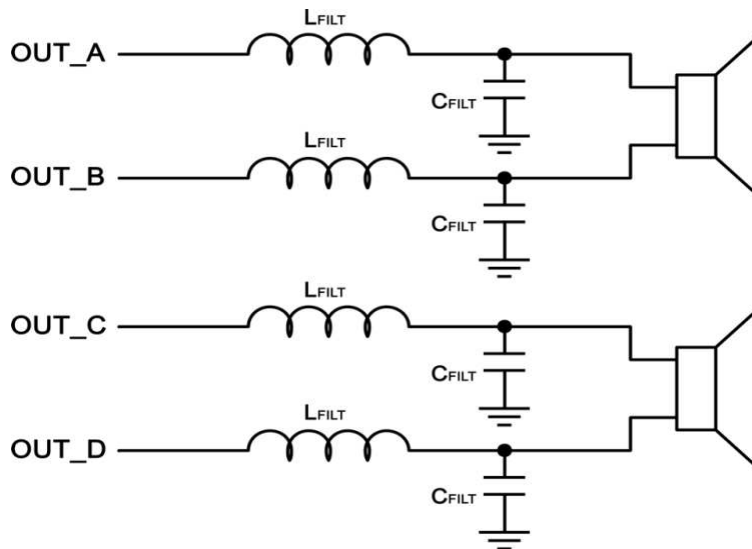

Figure 57. Stereo BTL Mode

9.4.2 Mono PBTL Mode

When this mode of operation is used, the two stereo outputs of the device are placed in parallel one with another to increase the power sourcing capabilities of the device. The TAS5731M supports parallel BTL (PBTL) mode with OUT_A/OUT_B (and OUT_C/OUT_D) connected before the LC filter.

The merging of the two output channels in this device can be done before the inductor portion of the output filter. This is called Single-Filter PBTL, and this mono operation is shown in [Figure 58](#). More information about this can be found in [Single-Filter PBTL Mode](#) section.

Device Functional Modes (continued)

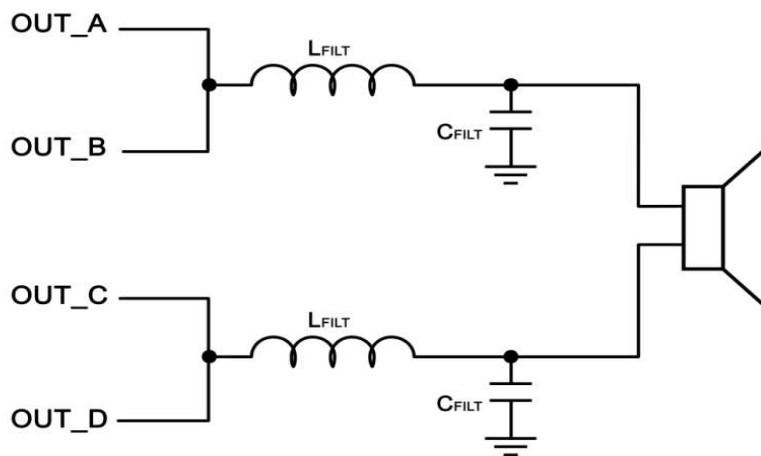

Figure 58. Post-Filter PBTL

On the input side of the TAS5731M device, the input signal to the mono amplifier can be selected from a mix, left or right frame from an I²S, LJ, or RJ signal. The routing of the audio data which is presented on the SPK_OUTx outputs must be configured with the PWM Output Mux Register (0x25).

Refer to the [Mono Parallel Bridge Tied Load Application](#) section for more details of the correct PBTL output connection of the TAS5731M.

9.4.3 2.1 Mode

2.1 Mode is defined as the application of two Single ended channels and one BTL channel used in systems where a third sub channel is required. Generally, both single-ended inputs drive the Left and Right channels, while the BTL channel drives a low-frequency content channel called often Subwoofer. More information about this can be found in the [2.1-Mode Support](#) section.

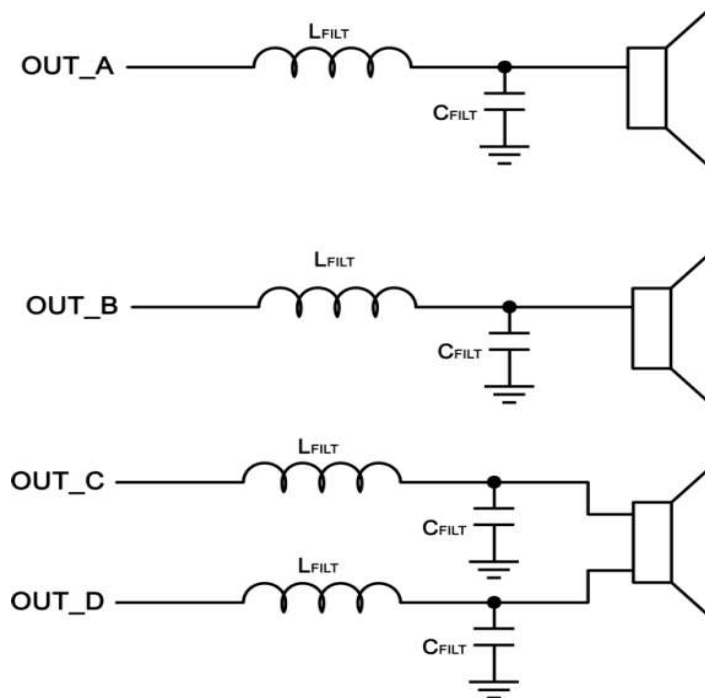
Device Functional Modes (continued)

Figure 59. 2.1 Mode

Refer to [2.1 Application](#) section for more details of the correct 2.1 output connection of the TAS5731M.

9.5 Programming

9.5.1 I²C Serial Control Interface

The TAS5731M DAP has a bidirectional I²C interface that is compatible with the Inter IC (I²C) bus protocol and supports both 100-kHz and 400-kHz data transfer rates for single- and multiple-byte write and read operations. This is a slave-only device that does not support a multimaster bus environment or wait-state insertion. The control interface is used to program the registers of the device and to read device status.

The DAP supports the standard-mode I²C bus operation (100 kHz maximum) and the fast I²C bus operation (400 kHz maximum). The DAP performs all I²C operations without I²C wait cycles.

9.5.1.1 General I²C Operation

The I²C bus employs two signals, SDA (data) and SCL (clock), to communicate between integrated circuits in a system. Data is transferred on the bus serially, one bit at a time. The address and data can be transferred in byte (8-bit) format, with the most-significant bit (MSB) transferred first. In addition, each byte transferred on the bus is acknowledged by the receiving device with an acknowledge bit. Each transfer operation begins with the master device driving a start condition on the bus and ends with the master device driving a stop condition on the bus. The bus uses transitions on the data pin (SDA) while the clock is high to indicate start and stop conditions. A high-to-low transition on SDA indicates a start and a low-to-high transition indicates a stop. Normal data-bit transitions must occur within the low time of the clock period. These conditions are shown in [Figure 60](#). The master generates the 7-bit slave address and the read/write (R/W) bit to open communication with another device and then waits for an acknowledge condition. The TAS5731M holds SDA low during the acknowledge clock period to indicate an acknowledgment. When this occurs, the master transmits the next byte of the sequence. Each device is addressed by a unique 7-bit slave address plus R/W bit (1 byte). All compatible devices share the same signals via a bidirectional bus using a wired-AND connection. An external pullup resistor must be used for the SDA and SCL signals to set the high level for the bus.

Programming (continued)

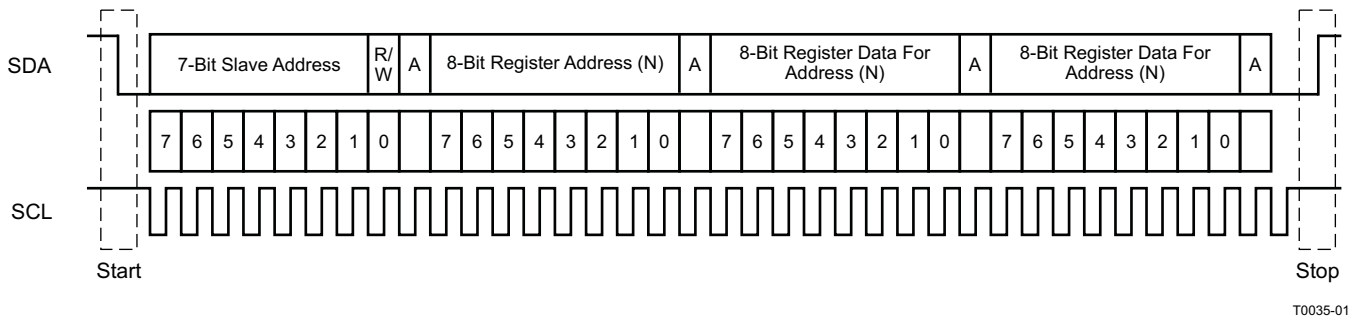

Figure 60. Typical I²C Sequence

There is no limit on the number of bytes that can be transmitted between start and stop conditions. When the last word transfers, the master generates a stop condition to release the bus. A generic data transfer sequence is shown in [Figure 60](#).

The 7-bit address for TAS5731M is 0011 011 (0x36).

9.5.1.2 Single- and Multiple-Byte Transfers

The serial control interface supports both single-byte and multiple-byte read/write operations for subaddresses 0x00 to 0x1F. However, for the subaddresses 0x20 to 0xFF, the serial control interface supports only multiple-byte read/write operations (in multiples of 4 bytes).

During multiple-byte read operations, the DAP responds with data, a byte at a time, starting at the subaddress assigned, as long as the master device continues to respond with acknowledges. If a particular subaddress does not contain 32 bits, the unused bits are read as logic 0.

During multiple-byte write operations, the DAP compares the number of bytes transmitted to the number of bytes that are required for each specific subaddress. For example, if a write command is received for a biquad subaddress, the DAP must receive five 32-bit words. If fewer than five 32-bit data words have been received when a stop command (or another start command) is received, the received data is discarded.

Supplying a subaddress for each subaddress transaction is referred to as random I²C addressing. The TAS5731M also supports sequential I²C addressing. For write transactions, if a subaddress is issued followed by data for that subaddress and the 15 subaddresses that follow, a sequential I²C write transaction has taken place, and the data for all 16 subaddresses is successfully received by the TAS5731M. For I²C sequential-write transactions, the subaddress then serves as the start address, and the amount of data subsequently transmitted, before a stop or start is transmitted, determines how many subaddresses are written. As was true for random addressing, sequential addressing requires that a complete set of data be transmitted. If only a partial set of data is written to the last subaddress, the data for the last subaddress is discarded. However, all other data written is accepted; only the incomplete data is discarded.

9.5.1.3 Single-Byte Write

As shown in [Figure 61](#), a single-byte data-write transfer begins with the master device transmitting a start condition followed by the I²C device address and the read/write bit. The read/write bit determines the direction of the data transfer. For a data-write transfer, the read/write bit is a 0. After receiving the correct I²C device address and the read/write bit, the DAP responds with an acknowledge bit. Next, the master transmits the address byte or bytes corresponding to the TAS5731M internal memory address being accessed. After receiving the address byte, the TAS5731M again responds with an acknowledge bit. Next, the master device transmits the data byte to be written to the memory address being accessed. After receiving the data byte, the TAS5731M again responds with an acknowledge bit. Finally, the master device transmits a stop condition to complete the single-byte data-write transfer.

Programming (continued)

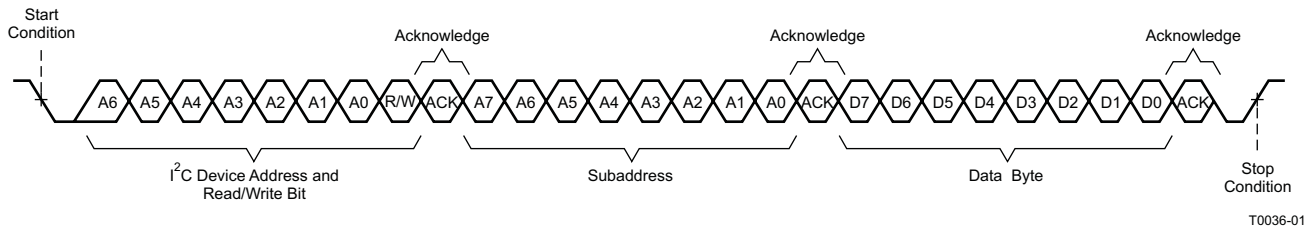

Figure 61. Single-Byte Write Transfer

9.5.1.4 Multiple-Byte Write

A multiple-byte data-write transfer is identical to a single-byte data-write transfer except that multiple data bytes are transmitted by the master device to the DAP as shown in Figure 62. After receiving each data byte, the TAS5731M responds with an acknowledge bit.

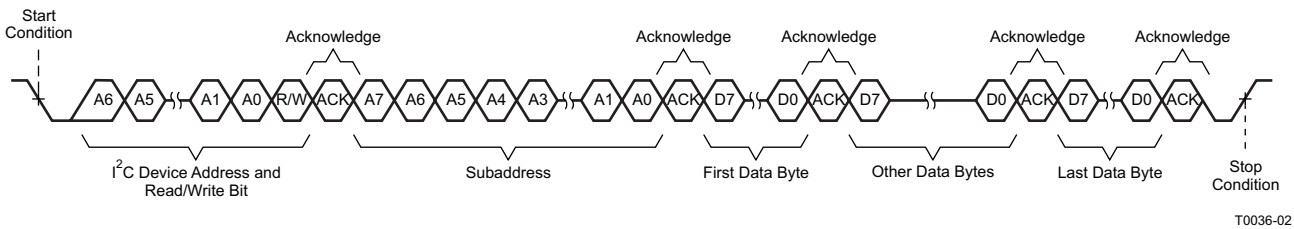

Figure 62. Multiple-Byte Write Transfer

9.5.1.5 Single-Byte Read

As shown in Figure 63, a single-byte data-read transfer begins with the master device transmitting a start condition, followed by the I²C device address and the read/write bit. For the data read transfer, both a write followed by a read are actually done. Initially, a write is done to transfer the address byte or bytes of the internal memory address to be read. As a result, the read/write bit becomes a 0. After receiving the TAS5731M address and the read/write bit, TAS5731M responds with an acknowledge bit. In addition, after sending the internal memory address byte or bytes, the master device transmits another start condition followed by the TAS5731M address and the read/write bit again. This time, the read/write bit becomes a 1, indicating a read transfer. After receiving the address and the read/write bit, the TAS5731M again responds with an acknowledge bit. Next, the TAS5731M transmits the data byte from the memory address being read. After receiving the data byte, the master device transmits a not-acknowledge followed by a stop condition to complete the single-byte data-read transfer.

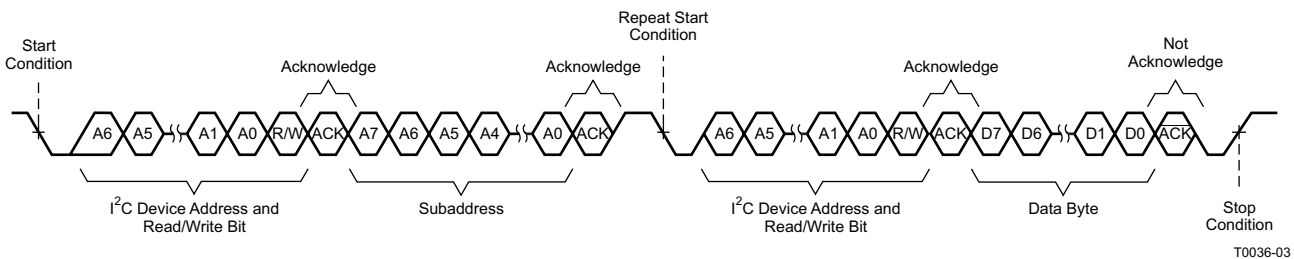

Figure 63. Single-Byte Read Transfer

9.5.1.6 Multiple-Byte Read

A multiple-byte data-read transfer is identical to a single-byte data-read transfer except that multiple data bytes are transmitted by the TAS5731M to the master device as shown in Figure 64. Except for the last data byte, the master device responds with an acknowledge bit after receiving each data byte.

Programming (continued)

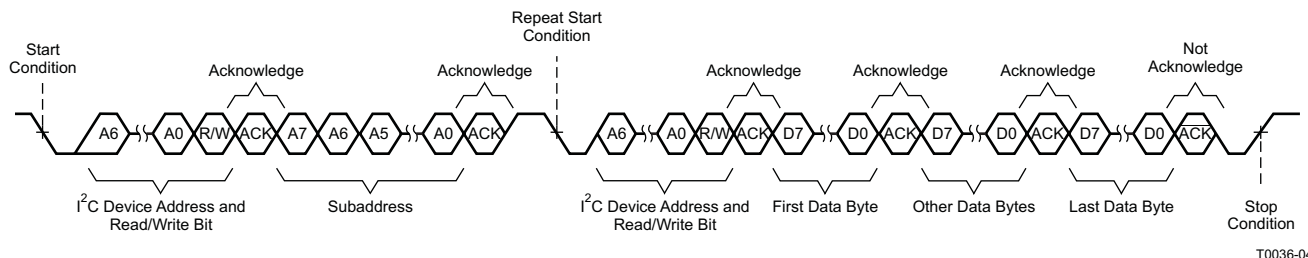

Figure 64. Multiple-Byte Read Transfer

9.5.2 26-Bit 3.23 Number Format

All mixer gain coefficients are 26-bit coefficients using a 3.23 number format. Numbers formatted as 3.23 numbers means that there are 3 bits to the left of the binary point and 23 bits to the right of the binary point. This is shown in Figure 65.

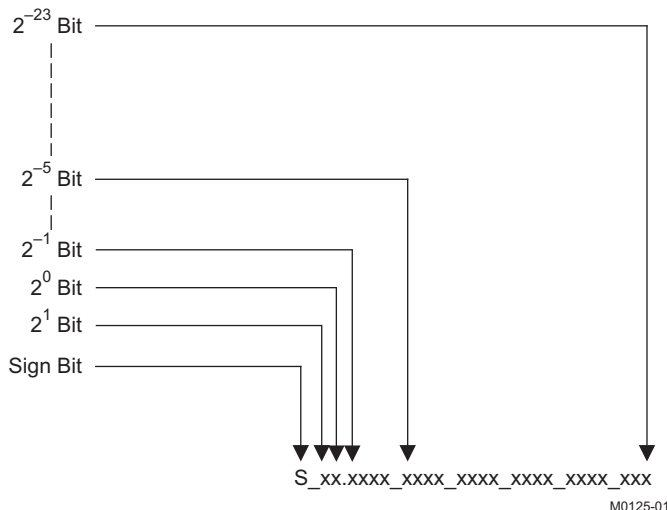

Figure 65. 3.23 Format

The decimal value of a 3.23 format number can be found by following the weighting shown in Figure 65. If the most significant bit is logic 0, the number is a positive number, and the weighting shown yields the correct number. If the most significant bit is a logic 1, then the number is a negative number. In this case every bit must be inverted, a 1 added to the result, and then the weighting shown in Figure 66 applied to obtain the magnitude of the negative number.

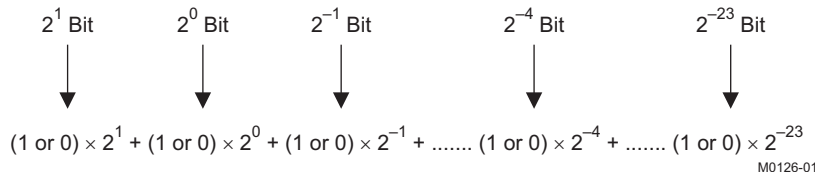
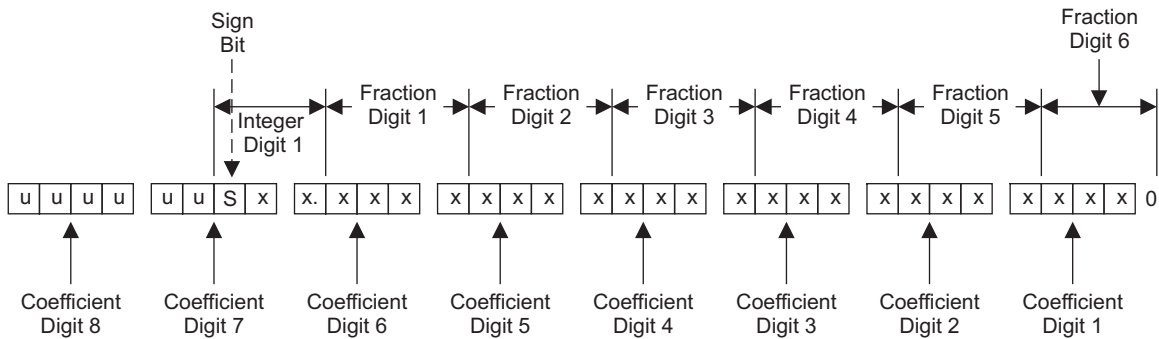

Figure 66. Conversion Weighting Factors — 3.23 Format To Floating Point

Gain coefficients, entered via the I²C bus, must be entered as 32-bit binary numbers. The format of the 32-bit number (4-byte or 8-digit hexadecimal number) is shown in Figure 67.

Programming (continued)



u = unused or don't care bits
Digit = hexadecimal digit

M0127-01

Figure 67. Alignment of 3.23 Coefficient in 32-Bit I²C Word

Table 1. Sample Calculation for 3.23 Format

db	LINEAR	DECIMAL	HEX (3.23 Format)
0	1	8,388,608	80 0000
5	1.77	14,917,288	00E3 9EA8
-5	0.56	4,717,260	0047 FACC
X	$L = 10^{(X/20)}$	$D = 8,388,608 \times L$	$H = \text{dec2hex}(D, 8)$

Table 2. Sample Calculation for 9.17 Format

db	LINEAR	DECIMAL	HEX (9.17 Format)
0	1	131,072	2 0000
5	1.77	231,997	3 8A3D
-5	0.56	73,400	1 1EB8
X	$L = 10^{(X/20)}$	$D = 131,072 \times L$	$H = \text{dec2hex}(D, 8)$

9.6 Register Maps

Table 3. Serial Control Interface Register Summary

SUBADDRESS	REGISTER NAME	NO. OF BYTES	CONTENTS ⁽¹⁾	INITIALIZATION VALUE
0x00	Clock control register	1	Description shown in subsequent section	0x6C
0x01	Device ID register	1	Description shown in subsequent section	0x00
0x02	Error status register	1	Description shown in subsequent section	0x00
0x03	System control register 1	1	Description shown in subsequent section	0xA0
0x04	Serial data interface register	1	Description shown in subsequent section	0x05
0x05	System control register 2	1	Description shown in subsequent section	0x40
0x06	Soft mute register	1	Description shown in subsequent section	0x00
0x07	Master volume	1	Description shown in subsequent section	0xFF (mute)
0x08	Channel 1 vol	1	Description shown in subsequent section	0x30 (0 dB)
0x09	Channel 2 vol	1	Description shown in subsequent section	0x30 (0 dB)
0x0A	Channel 3 vol	1	Description shown in subsequent section	0x30 (0 dB)
0x0B–0x0D		1	Reserved ⁽²⁾	
0x0E	Volume configuration register	1	Description shown in subsequent section	0x91
0x0F		1	Reserved ⁽²⁾	
0x10	Modulation limit register	1	Description shown in subsequent section	0x02
0x11	IC delay channel 1	1	Description shown in subsequent section	0xAC
0x12	IC delay channel 2	1	Description shown in subsequent section	0x54
0x13	IC delay channel 3	1	Description shown in subsequent section	0xAC
0x14	IC delay channel 4	1	Description shown in subsequent section	0x54
0x15–0x18		1	Reserved ⁽²⁾	
0x19	PWM channel shutdown group register	1	Description shown in subsequent section	0x30
0x1A	Start/stop period register	1		0x0F
0x1B	Oscillator trim register	1		0x82
0x1C	BKND_ERR register	1		0x02
0x1D–0x1F		1	Reserved ⁽²⁾	
0x20	Input MUX register	4	Description shown in subsequent section	0x0001 7772
0x21	Ch 4 source select register	4	Description shown in subsequent section	0x0000 4303
0x22–0x24		4	Reserved ⁽²⁾	
0x25	PWM MUX register	4	Description shown in subsequent section	0x0102 1345
0x26–0x28		4	Reserved ⁽²⁾	
0x29	ch1_bq[0]	20	u[31:26], b0[25:0]	0x0080 0000
			u[31:26], b1[25:0]	0x0000 0000
			u[31:26], b2[25:0]	0x0000 0000
			u[31:26], a1[25:0]	0x0000 0000
			u[31:26], a2[25:0]	0x0000 0000
0x2A	ch1_bq[1]	20	u[31:26], b0[25:0]	0x0080 0000
			u[31:26], b1[25:0]	0x0000 0000
			u[31:26], b2[25:0]	0x0000 0000
			u[31:26], a1[25:0]	0x0000 0000
			u[31:26], a2[25:0]	0x0000 0000

(1) A u indicates unused bits.

(2) Reserved registers must not be accessed.

Register Maps (continued)
Table 3. Serial Control Interface Register Summary (continued)

SUBADDRESS	REGISTER NAME	NO. OF BYTES	CONTENTS ⁽¹⁾	INITIALIZATION VALUE
0x2B	ch1_bq[2]	20	u[31:26], b0[25:0]	0x0080 0000
			u[31:26], b1[25:0]	0x0000 0000
			u[31:26], b2[25:0]	0x0000 0000
			u[31:26], a1[25:0]	0x0000 0000
			u[31:26], a2[25:0]	0x0000 0000
0x2C	ch1_bq[3]	20	u[31:26], b0[25:0]	0x0080 0000
			u[31:26], b1[25:0]	0x0000 0000
			u[31:26], b2[25:0]	0x0000 0000
			u[31:26], a1[25:0]	0x0000 0000
			u[31:26], a2[25:0]	0x0000 0000
0x2D	ch1_bq[4]	20	u[31:26], b0[25:0]	0x0080 0000
			u[31:26], b1[25:0]	0x0000 0000
			u[31:26], b2[25:0]	0x0000 0000
			u[31:26], a1[25:0]	0x0000 0000
			u[31:26], a2[25:0]	0x0000 0000
0x2E	ch1_bq[5]	20	u[31:26], b0[25:0]	0x0080 0000
			u[31:26], b1[25:0]	0x0000 0000
			u[31:26], b2[25:0]	0x0000 0000
			u[31:26], a1[25:0]	0x0000 0000
			u[31:26], a2[25:0]	0x0000 0000
0x2F	ch1_bq[6]	20	u[31:26], b0[25:0]	0x0080 0000
			u[31:26], b1[25:0]	0x0000 0000
			u[31:26], b2[25:0]	0x0000 0000
			u[31:26], a1[25:0]	0x0000 0000
			u[31:26], a2[25:0]	0x0000 0000
0x30	ch2_bq[0]	20	u[31:26], b0[25:0]	0x0080 0000
			u[31:26], b1[25:0]	0x0000 0000
			u[31:26], b2[25:0]	0x0000 0000
			u[31:26], a1[25:0]	0x0000 0000
			u[31:26], a2[25:0]	0x0000 0000
0x31	ch2_bq[1]	20	u[31:26], b0[25:0]	0x0080 0000
			u[31:26], b1[25:0]	0x0000 0000
			u[31:26], b2[25:0]	0x0000 0000
			u[31:26], a1[25:0]	0x0000 0000
			u[31:26], a2[25:0]	0x0000 0000
0x32	ch2_bq[2]	20	u[31:26], b0[25:0]	0x0080 0000
			u[31:26], b1[25:0]	0x0000 0000
			u[31:26], b2[25:0]	0x0000 0000
			u[31:26], a1[25:0]	0x0000 0000
			u[31:26], a2[25:0]	0x0000 0000
0x33	ch2_bq[3]	20	u[31:26], b0[25:0]	0x0080 0000
			u[31:26], b1[25:0]	0x0000 0000
			u[31:26], b2[25:0]	0x0000 0000
			u[31:26], a1[25:0]	0x0000 0000
			u[31:26], a2[25:0]	0x0000 0000

Register Maps (continued)
Table 3. Serial Control Interface Register Summary (continued)

SUBADDRESS	REGISTER NAME	NO. OF BYTES	CONTENTS ⁽¹⁾	INITIALIZATION VALUE
0x34	ch2_bq[4]	20	u[31:26], b0[25:0]	0x0080 0000
			u[31:26], b1[25:0]	0x0000 0000
			u[31:26], b2[25:0]	0x0000 0000
			u[31:26], a1[25:0]	0x0000 0000
			u[31:26], a2[25:0]	0x0000 0000
0x35	ch2_bq[5]	20	u[31:26], b0[25:0]	0x0080 0000
			u[31:26], b1[25:0]	0x0000 0000
			u[31:26], b2[25:0]	0x0000 0000
			u[31:26], a1[25:0]	0x0000 0000
			u[31:26], a2[25:0]	0x0000 0000
0x36	ch2_bq[6]	20	u[31:26], b0[25:0]	0x0080 0000
			u[31:26], b1[25:0]	0x0000 0000
			u[31:26], b2[25:0]	0x0000 0000
			u[31:26], a1[25:0]	0x0000 0000
			u[31:26], a2[25:0]	0x0000 0000
0x37 - 0x39		4	Reserved ⁽²⁾	
0x3A	DRC1 ae ⁽³⁾	8	u[31:26], ae[25:0]	0x0080 0000
	DRC1 (1 – ae)		u[31:26], (1 – ae)[25:0]	0x0000 0000
0x3B	DRC1 aa	8	u[31:26], aa[25:0]	0x0080 0000
	DRC1 (1 – aa)		u[31:26], (1 – aa)[25:0]	0x0000 0000
0x3C	DRC1 ad	8	u[31:26], ad[25:0]	0x0080 0000
	DRC1 (1 – ad)		u[31:26], (1 – ad)[25:0]	0x0000 0000
0x3D	DRC2 ae	8	u[31:26], ae[25:0]	0x0080 0000
	DRC 2 (1 – ae)		u[31:26], (1 – ae)[25:0]	0x0000 0000
0x3E	DRC2 aa	8	u[31:26], aa[25:0]	0x0080 0000
	DRC2 (1 – aa)		u[31:26], (1 – aa)[25:0]	0x0000 0000
0x3F	DRC2 ad	8	u[31:26], ad[25:0]	0x0080 0000
	DRC2 (1 – ad)		u[31:26], (1 – ad)[25:0]	0x0000 0000
0x40	DRC1-T	4	T1[31:0] (9.23 format)	0xFDA2 1490
0x41	DRC1-K	4	u[31:26], K1[25:0]	0x0384 2109
0x42	DRC1-O	4	u[31:26], O1[25:0]	0x0008 4210
0x43	DRC2-T	4	T2[31:0] (9.23 format)	0xFDA2 1490
0x44	DRC2-K	4	u[31:26], K2[25:0]	0x0384 2109
0x45	DRC2-O	4	u[31:26], O2[25:0]	0x0008 4210
0x46	DRC control	4	Description shown in subsequent section	0x0000 0000
0x47–0x4F		4	Reserved ⁽²⁾	
0x50	Bank switch control	4	Description shown in subsequent section	0x0F70 8000
0x51	Ch 1 output mixer	12	Ch 1 output mix1[2]	0x0080 0000
			Ch 1 output mix1[1]	0x0000 0000
			Ch 1 output mix1[0]	0x0000 0000
0x52	Ch 2 output mixer	12	Ch 2 output mix2[2]	0x0080 0000
			Ch 2 output mix2[1]	0x0000 0000
			Ch 2 output mix2[0]	0x0000 0000

(3) "ae" stands for ∞ of energy filter, "aa" stands for ∞ of attack filter and "ad" stands for ∞ of decay filter and $1 - \infty = \omega$.

Register Maps (continued)
Table 3. Serial Control Interface Register Summary (continued)

SUBADDRESS	REGISTER NAME	NO. OF BYTES	CONTENTS ⁽¹⁾	INITIALIZATION VALUE
0x53	Ch 1 input mixer	16	Ch 1 input mixer[3]	0x0080 0000
			Ch 1 input mixer[2]	0x0000 0000
			Ch 1 input mixer[1]	0x0000 0000
			Ch 1 input mixer[0]	0x0080 0000
0x54	Ch 2 input mixer	16	Ch 2 input mixer[3]	0x0080 0000
			Ch 2 input mixer[2]	0x0000 0000
			Ch 2 input mixer[1]	0x0000 0000
			Ch 2 input mixer[0]	0x0080 0000
0x55	Channel 3 input mixer	12	Channel 3 input mixer [2]	0x0080 0000
			Channel 3 input mixer [1]	0x0000 0000
			Channel 3 input mixer [0]	0x0000 0000
0x56	Output post-scale	4	u[31:26], post[25:0]	0x0080 0000
0x57	Output pre-scale	4	u[31:26], pre[25:0] (9.17 format)	0x0002 0000
0x58	ch1 BQ[7]	20	u[31:26], b0[25:0]	0x0080 0000
			u[31:26], b1[25:0]	0x0000 0000
			u[31:26], b2[25:0]	0x0000 0000
			u[31:26], a1[25:0]	0x0000 0000
			u[31:26], a2[25:0]	0x0000 0000
0x59	ch1 BQ[8]	20	u[31:26], b0[25:0]	0x0080 0000
			u[31:26], b1[25:0]	0x0000 0000
			u[31:26], b2[25:0]	0x0000 0000
			u[31:26], a1[25:0]	0x0000 0000
			u[31:26], a2[25:0]	0x0000 0000
0x5A	Subchannel BQ[0]	20	u[31:26], b0[25:0]	0x0080 0000
			u[31:26], b1[25:0]	0x0000 0000
			u[31:26], b2[25:0]	0x0000 0000
			u[31:26], a1[25:0]	0x0000 0000
			u[31:26], a2[25:0]	0x0000 0000
0x5B	Subchannel BQ[1]	20	u[31:26], b0[25:0]	0x0080 0000
			u[31:26], b1[25:0]	0x0000 0000
			u[31:26], b2[25:0]	0x0000 0000
			u[31:26], a1[25:0]	0x0000 0000
			u[31:26], a2[25:0]	0x0000 0000
0x5C	ch2 BQ[7]	20	u[31:26], b0[25:0]	0x0080 0000
			u[31:26], b1[25:0]	0x0000 0000
			u[31:26], b2[25:0]	0x0000 0000
			u[31:26], a1[25:0]	0x0000 0000
			u[31:26], a2[25:0]	0x0000 0000
0x5D	ch2 BQ[8]	20	u[31:26], b0[25:0]	0x0080 0000
			u[31:26], b1[25:0]	0x0000 0000
			u[31:26], b2[25:0]	0x0000 0000
			u[31:26], a1[25:0]	0x0000 0000
			u[31:26], a2[25:0]	0x0000 0000

Register Maps (continued)
Table 3. Serial Control Interface Register Summary (continued)

SUBADDRESS	REGISTER NAME	NO. OF BYTES	CONTENTS ⁽¹⁾	INITIALIZATION VALUE
0x5E	pseudo_ch2 BQ[0]	20	u[31:26], b0[25:0]	0x0080 0000
			u[31:26], b1[25:0]	0x0000 0000
			u[31:26], b2[25:0]	0x0000 0000
			u[31:26], a1[25:0]	0x0000 0000
			u[31:26], a2[25:0]	0x0000 0000
0x5F		4	Reserved ⁽²⁾	
0x60	Channel 4 (subchannel) output mixer	8	Ch 4 output mixer[1]	0x0000 0000
			Ch 4 output mixer[0]	0x0080 0000
0x61	Channel 4 (subchannel) input mixer	8	Ch 4 input mixer[1]	0x0040 0000
			Ch 4 input mixer[0]	0x0040 0000
0x62	IDF post scale	4	Post-IDF attenuation register	0x0000 0080
0x63–0xF7			Reserved ⁽²⁾	0x0000 0000
0xF8	Device address enable register	4	Write F9 A5 A5 A5 in this register to enable write to device address update (0xF9)	0x0000 0000
0xF9	Device address Update Register	4	u[31:8], New Dev Id[7:1] , ZERO[0] (New Dev Id (7:1) defines the new device address	0X0000 0036
0xFA–0xFF		4	Reserved ⁽²⁾	0x0000 0000

All DAP coefficients are 3.23 format unless specified otherwise.

9.6.1 Clock Control Register (0x00)

The clocks and data rates are automatically determined by the TAS5731M. The clock control register contains the auto-detected clock status. Bits D7–D5 reflect the sample rate. Bits D4–D2 reflect the MCLK frequency. The device accepts a $64 f_S$ or $32 f_S$ SCLK rate for all MCLK ratios, but accepts a $48 f_S$ SCLK rate for MCLK ratios of $192 f_S$ and $384 f_S$ only.

Table 4. Clock Control Register (0x00)

D7	D6	D5	D4	D3	D2	D1	D0	FUNCTION
0	0	0	–	–	–	–	–	$f_S = 32\text{-kHz}$ sample rate
0	0	1	–	–	–	–	–	Reserved ⁽¹⁾
0	1	0	–	–	–	–	–	Reserved ⁽¹⁾
0	1	1	–	–	–	–	–	$f_S = 44.1/48\text{-kHz}$ sample rate⁽²⁾
1	0	0	–	–	–	–	–	$f_S = 16\text{-kHz}$ sample rate
1	0	1	–	–	–	–	–	$f_S = 22.05/24\text{-kHz}$ sample rate
1	1	0	–	–	–	–	–	$f_S = 8\text{-kHz}$ sample rate
1	1	1	–	–	–	–	–	$f_S = 11.025/12\text{-kHz}$ sample rate
–	–	–	0	0	0	–	–	MCLK frequency = $64 \times f_S$ ⁽³⁾
–	–	–	0	0	1	–	–	MCLK frequency = $128 \times f_S$ ⁽³⁾
–	–	–	0	1	0	–	–	MCLK frequency = $192 \times f_S$ ⁽⁴⁾
–	–	–	0	1	1	–	–	MCLK frequency = $256 \times f_S$ ⁽²⁾⁽⁵⁾
–	–	–	1	0	0	–	–	MCLK frequency = $384 \times f_S$
–	–	–	1	0	1	–	–	MCLK frequency = $512 \times f_S$
–	–	–	1	1	0	–	–	Reserved ⁽¹⁾
–	–	–	1	1	1	–	–	Reserved ⁽¹⁾
–	–	–	–	–	–	0	–	Reserved ^{(1) (2)}
–	–	–	–	–	–	–	0	Reserved ^{(1) (2)}

(1) Reserved registers must not be accessed.

(2) Default values are in **bold**.

(3) Only available for 44.1-kHz and 48-kHz rates

(4) Rate only available for 32/44.1/48-kHz sample rates

(5) Not available at 8 kHz

9.6.2 Device ID Register (0x01)

The device ID register contains the ID code for the firmware revision.

Table 5. General Status Register (0x01)

D7	D6	D5	D4	D3	D2	D1	D0	FUNCTION
0	0	0	0	0	0	0	0	Identification code

9.6.3 Error Status Register (0x02)

The error bits are sticky and are not cleared by the hardware. This means that the software must clear the register (write zeroes) and then read them to determine if they are persistent errors.

Error Definitions:

- MCLK Error : MCLK frequency is changing. The number of MCLKs per LRCLK is changing.
- SCLK Error: The number of SCLKs per LRCLK is changing.
- LRCLK Error: LRCLK frequency is changing.
- Frame Slip: LRCLK phase is drifting with respect to internal Frame Sync.

Table 6. Error Status Register (0x02)

D7	D6	D5	D4	D3	D2	D1	D0	FUNCTION
1	-	-	-	-	-	-	-	MCLK error
-	1	-	-	-	-	-	-	PLL autolock error
-	-	1	-	-	-	-	-	SCLK error
-	-	-	1	-	-	-	-	LRCLK error
-	-	-	-	1	-	-	-	Frame slip
-	-	-	-	-	1	-	-	Clip indicator
-	-	-	-	-	-	1	-	Overcurrent, overtemperature, or undervoltage errors
-	-	-	-	-	-	-	0	Reserved
0	0	0	0	0	0	0	-	No errors⁽¹⁾

(1) Default values are in **bold**.

9.6.4 System Control Register 1 (0x03)

The system control register 1 has several functions:

Bit D7: If 0, the dc-blocking filter for each channel is disabled.

If 1, the dc-blocking filter (-3 dB cutoff <1 Hz) for each channel is enabled (default).

Bit D5: If 0, use soft unmute on recovery from clock error. This is a slow recovery. Unmute takes the same time as the volume ramp defined in register 0x0E.

If 1, use hard unmute on recovery from clock error (default). This is a fast recovery, a single step volume ramp

Bits D1–D0: Select de-emphasis

Table 7. System Control Register 1 (0x03)

D7	D6	D5	D4	D3	D2	D1	D0	FUNCTION
0	-	-	-	-	-	-	-	PWM high-pass (dc blocking) disabled
1	-	-	-	-	-	-	-	PWM high-pass (dc blocking) enabled⁽¹⁾
-	0	-	-	-	-	-	-	Reserved⁽¹⁾
-	-	0	-	-	-	-	-	Soft unmute on recovery from clock error
-	-	1	-	-	-	-	-	Hard unmute on recovery from clock error⁽¹⁾
-	-	-	0	-	-	-	-	Reserved⁽¹⁾
-	-	-	-	0	-	-	-	Reserved⁽¹⁾
-	-	-	-	-	0	-	-	Reserved⁽¹⁾
-	-	-	-	-	-	0	0	No de-emphasis⁽¹⁾
-	-	-	-	-	-	0	1	De-emphasis for $f_S = 32$ kHz
-	-	-	-	-	-	1	0	De-emphasis for $f_S = 44.1$ kHz
-	-	-	-	-	-	1	1	De-emphasis for $f_S = 48$ kHz

(1) Default values are in **bold**.

9.6.5 Serial Data Interface Register (0x04)

As shown in [Table 8](#), the TAS5731M supports 9 serial data modes. The default is 24-bit, I²S mode,

Table 8. Serial Data Interface Control Register (0x04)

RECEIVE SERIAL DATA INTERFACE FORMAT	WORD LENGTH	D7–D4	D3	D2	D1	D0
Right-justified	16	0000	0	0	0	0
Right-justified	20	0000	0	0	0	1
Right-justified	24	0000	0	0	1	0
I ² S	16	000	0	0	1	1
I ² S	20	0000	0	1	0	0
I²S ⁽¹⁾	24	0000	0	1	0	1
Left-justified	16	0000	0	1	1	0
Left-justified	20	0000	0	1	1	1
Left-justified	24	0000	1	0	0	0
Reserved		0000	1	0	0	1
Reserved		0000	1	0	1	0
Reserved		0000	1	0	1	1
Reserved		0000	1	1	0	0
Reserved		0000	1	1	0	1
Reserved		0000	1	1	1	0
Reserved		0000	1	1	1	1

(1) Default values are in **bold**.

9.6.6 System Control Register 2 (0x05)

When bit D6 is set low, the system exits all channel shutdown and starts playing audio; otherwise, the outputs are shut down (hard mute).

Table 9. System Control Register 2 (0x05)

D7	D6	D5	D4	D3	D2	D1	D0	FUNCTION
0	–	–	–	–	–	–	–	Mid-Z ramp disabled ⁽¹⁾
1	–	–	–	–	–	–	–	Mid-Z ramp enabled
–	0	–	–	–	–	–	–	Exit all-channel shutdown (normal operation)
–	1	–	–	–	–	–	–	Enter all-channel shutdown (hard mute) ⁽¹⁾
				0				Sub-channel in AD Mode
				1				Sub-channel in BD Mode
–	–	–	–	–	0	–	–	2.0 mode [2.0 BTL] ⁽¹⁾
–	–	–	–	–	1	–	–	2.1 mode [2 SE + 1 BTL]
–	–	–	–	–	–	0	–	ADR/$\overline{\text{FAULT}}$ pin is configured as to serve as an address input only ⁽¹⁾
–	–	–	–	–	–	1	–	ADR/ $\overline{\text{FAULT}}$ pin is configured as fault output
–	–	0	0	–	–	–	0	Reserved ⁽¹⁾

(1) Default values are in **bold**.

9.6.7 Soft Mute Register (0x06)

Writing a 1 to any of the following bits sets the output of the respective channel to 50% duty cycle (soft mute).

Table 10. Soft Mute Register (0x06)

D7	D6	D5	D4	D3	D2	D1	D0	FUNCTION
0	0	0	0	0	–	–	–	Reserved ⁽¹⁾
–	–	–	–	–	0	–	–	Soft unmute channel 3 ⁽¹⁾
–	–	–	–	–	1	–	–	Soft mute channel 3
–	–	–	–	–	–	0	–	Soft unmute channel 2 ⁽¹⁾
–	–	–	–	–	–	1	–	Soft mute channel 2
–	–	–	–	–	–	–	0	Soft unmute channel 1 ⁽¹⁾
–	–	–	–	–	–	–	1	Soft mute channel 1

(1) Default values are in **bold**.

9.6.8 Volume Registers (0x07, 0x08, 0x09, 0x0A)

Step size is 0.5 dB.

Master volume	– 0x07 (default is mute)
Channel-1 volume	– 0x08 (default is 0 dB)
Channel-2 volume	– 0x09 (default is 0 dB)
Channel-3 volume	– 0x0A (default is 0 dB)

Table 11. Volume Registers (0x07, 0x08, 0x09, 0x0A)

D7	D6	D5	D4	D3	D2	D1	D0	FUNCTION
0	0	0	0	0	0	0	0	24 dB
0	0	1	1	0	0	0	0	0 dB (default for individual channel volume)⁽¹⁾
1	1	1	1	1	1	1	0	–103 dB
1	1	1	1	1	1	1	1	Soft mute (default for master volume)⁽¹⁾

(1) Default values are in **bold**.

9.6.9 Volume Configuration Register (0x0E)

Bits D2–D0: Volume slew rate (Used to control volume change and MUTE ramp rates). These bits control the number of steps in a volume ramp. Volume steps occur at a rate that depends on the sample rate of the I²S data as follows

Sample Rate (KHz)	Approximate Ramp Rate
8/16/32	125 μ s/step
11.025/22.05/44.1	90.7 μ s/step
12/24/48	83.3 μ s/step

Table 12. Volume Control Register (0x0E)

D7	D6	D5	D4	D3	D2	D1	D0	FUNCTION
1	–	–	1	0	–	–	–	Reserved ⁽¹⁾
–	0	–	–	–	–	–	–	Subchannel (ch4) volume = ch1 volume ^{(2) (1)}
–	1	–	–	–	–	–	–	Subchannel volume = register 0x0A ⁽²⁾
–	–	0	–	–	–	–	–	Ch3 volume = ch2 volume ⁽¹⁾
–	–	1	–	–	–	–	–	Ch3 volume = register 0x0A
–	–	–	–	–	0	0	0	Volume slew 512 steps (43-ms volume ramp time at 48 kHz)
–	–	–	–	–	0	0	1	Volume slew 1024 steps (85-ms volume ramp time at 48 kHz) ⁽¹⁾
–	–	–	–	–	0	1	0	Volume slew 2048 steps (171- ms volume ramp time at 48 kHz)
–	–	–	–	–	0	1	1	Volume slew 256 steps (21-ms volume ramp time at 48 kHz)
–	–	–	–	–	1	X	X	Reserved

(1) Default values are in **bold**.

(2) Bits 6:5 can be changed only when volume is in MUTE [master volume = MUTE (register 0x07 = 0xFF)].

9.6.10 Modulation Limit Register (0x10)

The modulation limit is the maximum duty cycle of the PWM output waveform.

Table 13. Modulation Limit Register (0x10)

D7	D6	D5	D4	D3	D2	D1	D0	MODULATION LIMIT
–	–	–	–	–	0	0	0	99.2%
–	–	–	–	–	0	0	1	98.4%
–	–	–	–	–	0	1	0	97.7% ⁽¹⁾
–	–	–	–	–	0	1	1	96.9%
–	–	–	–	–	1	0	0	96.1%
–	–	–	–	–	1	0	1	95.3%
–	–	–	–	–	1	1	0	94.5%
–	–	–	–	–	1	1	1	93.8%
0	0	0	0	0	–	–	–	Reserved

(1) Default values are in **bold**.

9.6.11 Interchannel Delay Registers (0x11, 0x12, 0x13, and 0x14)

Internal PWM Channels 1, 2, $\bar{1}$, and $\bar{2}$ are mapped into registers 0x11, 0x12, 0x13, and 0x14.

Table 14. Channel Interchannel Delay Registers (0x11, 0x12, 0x13, and 0x14)

BITS DEFINITION	D7	D6	D5	D4	D3	D2	D1	D0	FUNCTION
	0	0	0	0	0	0	–	–	Minimum absolute delay, 0 DCLK cycles
	0	1	1	1	1	1	–	–	Maximum positive delay, 31 × 4 DCLK cycles
	1	0	0	0	0	0	–	–	Maximum negative delay, –32 × 4 DCLK cycles
							0	0	Reserved
SUBADDRESS	D7	D6	D5	D4	D3	D2	D1	D0	DELAY = (VALUE) × 4 DCLKs
0x11	1	0	1	0	1	1	–	–	Default value for channel 1⁽¹⁾
0x12	0	1	0	1	0	1	–	–	Default value for channel 2⁽¹⁾
0x13	1	0	1	0	1	1	–	–	Default value for channel $\bar{1}$⁽¹⁾
0x14	0	1	0	1	0	1	–	–	Default value for channel $\bar{2}$⁽¹⁾

(1) Default values are in **bold**.

ICD settings have high impact on audio performance (e.g., dynamic range, THD, crosstalk etc.). Therefore, appropriate ICD settings must be used. By default, the device has ICD settings for AD mode. If used in BD mode, then update these registers before coming out of all-channel shutdown.

REGISTER	AD MODE	BD MODE
0x11	AC	B8
0x12	54	60
0x13	AC	A0
0x14	54	48

9.6.12 PWM Shutdown Group Register (0x19)

Settings of this register determine which PWM channels are active. The value must be 0x30 for BTL mode and 0x3A for PBT mode. The default value of this register is 0x30. The functionality of this register is tied to the state of bit D5 in the system control register.

This register defines which channels belong to the shutdown group (SDG). If a 1 is set in the shutdown group register, that particular channel is **not** started following an exit *out of all-channel shutdown* command (if bit D5 is set to 0 in system control register 2, 0x05).

Table 15. Shutdown Group Register (0x19)

D7	D6	D5	D4	D3	D2	D1	D0	FUNCTION
0	–	–	–	–	–	–	–	Reserved ⁽¹⁾
–	0	–	–	–	–	–	–	Reserved ⁽¹⁾
–	–	1	–	–	–	–	–	Reserved ⁽¹⁾
–	–	–	1	–	–	–	–	Reserved ⁽¹⁾
–	–	–	–	0	–	–	–	PWM channel 4 does not belong to shutdown group.⁽¹⁾
–	–	–	–	1	–	–	–	PWM channel 4 belongs to shutdown group.
–	–	–	–	–	0	–	–	PWM channel 3 does not belong to shutdown group.⁽¹⁾
–	–	–	–	–	1	–	–	PWM channel 3 belongs to shutdown group.
–	–	–	–	–	–	0	–	PWM channel 2 does not belong to shutdown group.⁽¹⁾
–	–	–	–	–	–	1	–	PWM channel 2 belongs to shutdown group.
–	–	–	–	–	–	–	0	PWM channel 1 does not belong to shutdown group.⁽¹⁾
–	–	–	–	–	–	–	1	PWM channel 1 belongs to shutdown group.

(1) Default values are in **bold**.

9.6.13 Start/Stop Period Register (0x1A)

This register is used to control the soft-start and soft-stop period following an enter/exit all channel shut down command or change in the PDN state. This helps reduce pops and clicks at start-up and shutdown. The times are only approximate and vary depending on device activity level and I²S clock stability.

Table 16. Start/Stop Period Register (0x1A)

D7	D6	D5	D4	D3	D2	D1	D0	FUNCTION
0	–	–	–	–	–	–	–	SSTIMER enabled ⁽¹⁾
1	–	–	–	–	–	–	–	SSTIMER disabled
–	0	0	–	–	–	–	–	Reserved ⁽¹⁾
–	–	–	0	0	–	–	–	No 50% duty cycle start/stop period
–	–	–	0	1	0	0	0	16.5-ms 50% duty cycle start/stop period
–	–	–	0	1	0	0	1	23.9-ms 50% duty cycle start/stop period
–	–	–	0	1	0	1	0	31.4-ms 50% duty cycle start/stop period
–	–	–	0	1	0	1	1	40.4-ms 50% duty cycle start/stop period
–	–	–	0	1	1	0	0	53.9-ms 50% duty cycle start/stop period
–	–	–	0	1	1	0	1	70.3-ms 50% duty cycle start/stop period
–	–	–	0	1	1	1	0	94.2-ms 50% duty cycle start/stop period
–	–	–	0	1	1	1	1	125.7-ms 50% duty cycle start/stop period ⁽¹⁾
–	–	–	1	0	0	0	0	164.6-ms 50% duty cycle start/stop period
–	–	–	1	0	0	0	1	239.4-ms 50% duty cycle start/stop period
–	–	–	1	0	0	1	0	314.2-ms 50% duty cycle start/stop period
–	–	–	1	0	0	1	1	403.9-ms 50% duty cycle start/stop period
–	–	–	1	0	1	0	0	538.6-ms 50% duty cycle start/stop period
–	–	–	1	0	1	0	1	703.1-ms 50% duty cycle start/stop period
–	–	–	1	0	1	1	0	942.5-ms 50% duty cycle start/stop period
–	–	–	1	0	1	1	1	1256.6-ms 50% duty cycle start/stop period
–	–	–	1	1	0	0	0	1728.1-ms 50% duty cycle start/stop period
–	–	–	1	1	0	0	1	2513.6-ms 50% duty cycle start/stop period
–	–	–	1	1	0	1	0	3299.1-ms 50% duty cycle start/stop period
–	–	–	1	1	0	1	1	4241.7-ms 50% duty cycle start/stop period
–	–	–	1	1	1	0	0	5655.6-ms 50% duty cycle start/stop period
–	–	–	1	1	1	0	1	7383.7-ms 50% duty cycle start/stop period
–	–	–	1	1	1	1	0	9897.3-ms 50% duty cycle start/stop period
–	–	–	1	1	1	1	1	13,196.4-ms 50% duty cycle start/stop period

(1) Default values are in **bold**.

9.6.14 Oscillator Trim Register (0x1B)

The TAS5731M PWM processor contains an internal oscillator to support autodetect of I²S clock rates. This reduces system cost because an external reference is not required. Currently, TI recommends a reference resistor value of 18.2 kΩ (1%). This must be connected between OSC_RES and DVSSO.

Writing 0x00 to register 0x1B enables the trim that was programmed at the factory.

NOTE

Trim must always be run following reset of the device.

Table 17. Oscillator Trim Register (0x1B)

D7	D6	D5	D4	D3	D2	D1	D0	FUNCTION
0	–	–	–	–	–	–	–	Reserved ⁽¹⁾
–	0	–	–	–	–	–	–	Oscillator trim not done (read-only) ⁽¹⁾
–	1	–	–	–	–	–	–	Oscillator trim done (read only)
–	–	0	0	0	0	–	–	Reserved ⁽¹⁾
–	–	–	–	–	–	0	–	Select factory trim (Write a 0 to select factory trim; default is 1.)
–	–	–	–	–	–	1	–	Factory trim disabled ⁽¹⁾
–	–	–	–	–	–	–	0	Reserved ⁽¹⁾

(1) Default values are in **bold**.

9.6.15 BKND_ERR Register (0x1C)

When a back-end error signal is received from the internal power stage, the power stage is reset stopping all PWM activity. Subsequently, the modulator waits approximately for the time listed in [Table 18](#) before attempting to re-start the power stage.

Table 18. BKND_ERR Register (0x1C)⁽¹⁾

D7	D6	D5	D4	D3	D2	D1	D0	FUNCTION
0	0	0	0	0	0	0	X	Reserved
–	–	–	–	0	0	1	0	Set back-end reset period to 299 ms ⁽²⁾
–	–	–	–	0	0	1	1	Set back-end reset period to 449 ms
–	–	–	–	0	1	0	0	Set back-end reset period to 598 ms
–	–	–	–	0	1	0	1	Set back-end reset period to 748 ms
–	–	–	–	0	1	1	0	Set back-end reset period to 898 ms
–	–	–	–	0	1	1	1	Set back-end reset period to 1047 ms
–	–	–	–	1	0	0	0	Set back-end reset period to 1197 ms
–	–	–	–	1	0	0	1	Set back-end reset period to 1346 ms
–	–	–	–	1	0	1	X	Set back-end reset period to 1496 ms
–	–	–	–	1	1	X	X	Set back-end reset period to 1496 ms

(1) This register can be written only with a "non-Reserved" value. Also this register can be written once after the reset.

(2) Default values are in **bold**.

9.6.16 Input Multiplexer Register (0x20)

This register controls the modulation scheme (AD or BD mode) as well as the routing of I²S audio to the internal channels.

Table 19. Input Multiplexer Register (0x20)

D31	D30	D29	D28	D27	D26	D25	D24	FUNCTION
0	0	0	0	0	0	0	0	Reserved ⁽¹⁾
D23	D22	D21	D20	D19	D18	D17	D16	FUNCTION
0	–	–	–	–	–	–	–	Channel-1 AD mode⁽¹⁾
1	–	–	–	–	–	–	–	Channel-1 BD mode
–	0	0	0	–	–	–	–	SDIN-L to channel 1⁽¹⁾
–	0	0	1	–	–	–	–	SDIN-R to channel 1
–	0	1	0	–	–	–	–	Reserved
–	0	1	1	–	–	–	–	Reserved
–	1	0	0	–	–	–	–	Reserved
–	1	0	1	–	–	–	–	Reserved
–	1	1	0	–	–	–	–	Ground (0) to channel 1
–	1	1	1	–	–	–	–	Reserved
–	–	–	–	0	–	–	–	Channel 2 AD mode⁽¹⁾
–	–	–	–	1	–	–	–	Channel 2 BD mode
–	–	–	–	–	0	0	0	SDIN-L to channel 2
–	–	–	–	–	0	0	1	SDIN-R to channel 2⁽¹⁾
–	–	–	–	–	0	1	0	Reserved
–	–	–	–	–	0	1	1	Reserved
–	–	–	–	–	1	0	0	Reserved
–	–	–	–	–	1	0	1	Reserved
–	–	–	–	–	1	1	0	Ground (0) to channel 2
–	–	–	–	–	1	1	1	Reserved
D15	D14	D13	D12	D11	D10	D9	D8	FUNCTION
0	1	1	1	0	1	1	1	Reserved ⁽¹⁾
D7	D6	D5	D4	D3	D2	D1	D0	FUNCTION
0	1	1	1	0	0	1	0	Reserved ⁽¹⁾

(1) Default values are in **bold**.

9.6.17 Channel 4 Source Select Register (0x21)

This register selects the channel 4 source.

Table 20. Subchannel Control Register (0x21)

D31	D30	D29	D28	D27	D26	D25	D24	FUNCTION
0	0	0	0	0	0	0	0	Reserved ⁽¹⁾
D23	D22	D21	D20	D19	D18	D17	D16	FUNCTION
0	0	0	0	0	0	0	0	Reserved ⁽¹⁾
D15	D14	D13	D12	D11	D10	D9	D8	FUNCTION
0	1	0	0	0	0	1	1	Select SDIN path (third path), not available in TAS5731M ⁽¹⁾
–	–	–	–	–	–	–	0	(L + R)/2
–	–	–	–	–	–	0	1	Left-channel post-BQ ⁽¹⁾
D7	D6	D5	D4	D3	D2	D1	D0	FUNCTION
0	0	0	0	0	0	1	1	Reserved ⁽¹⁾

(1) Default values are in **bold**.

9.6.18 PWM Output Mux Register (0x25)

This DAP output mux selects which internal PWM channel is output to the external pins. Any channel can be output to any external output pin.

Bits D21–D20: Selects which PWM channel is output to OUT_A

Bits D17–D16: Selects which PWM channel is output to OUT_B

Bits D13–D12: Selects which PWM channel is output to OUT_C

Bits D09–D08: Selects which PWM channel is output to OUT_D

NOTE

Channels are encoded so that channel 1 = 0x00, channel 2 = 0x01, ..., channel 4 = 0x03.

Table 21. PWM Output Mux Register (0x25)

D31	D30	D29	D28	D27	D26	D25	D24	FUNCTION
0	0	0	0	0	0	0	1	Reserved ⁽¹⁾
D23	D22	D21	D20	D19	D18	D17	D16	FUNCTION
0	0	–	–	–	–	–	–	Reserved ⁽¹⁾
–	–	0	0	–	–	–	–	Multiplex PWM 1 to OUT_A ⁽¹⁾
–	–	0	1	–	–	–	–	Multiplex PWM 2 to OUT_A
–	–	1	0	–	–	–	–	Multiplex PWM 3 to OUT_A
–	–	1	1	–	–	–	–	Multiplex PWM 4 to OUT_A
–	–	–	–	0	0	–	–	Reserved ⁽¹⁾
–	–	–	–	–	–	0	0	Multiplex PWM 1 to OUT_B
–	–	–	–	–	–	0	1	Multiplex PWM 2 to OUT_B
–	–	–	–	–	–	1	0	Multiplex PWM 3 to OUT_B ⁽¹⁾
–	–	–	–	–	–	1	1	Multiplex PWM 4 to OUT_B

(1) Default values are in **bold**.

Table 21. PWM Output Mux Register (0x25) (continued)

D15	D14	D13	D12	D11	D10	D9	D8	FUNCTION
0	0	–	–	–	–	–	–	Reserved ⁽¹⁾
–	–	0	0	–	–	–	–	Multiplex PWM 1 to OUT_C
–	–	0	1	–	–	–	–	Multiplex PWM 2 to OUT_C ⁽¹⁾
–	–	1	0	–	–	–	–	Multiplex PWM 3 to OUT_C
–	–	1	1	–	–	–	–	Multiplex PWM 4 to OUT_C
–	–	–	–	0	0	–	–	Reserved ⁽¹⁾
–	–	–	–	–	–	0	0	Multiplex PWM 1 to OUT_D
–	–	–	–	–	–	0	1	Multiplex PWM 2 to OUT_D
–	–	–	–	–	–	1	0	Multiplex PWM 3 to OUT_D
–	–	–	–	–	–	1	1	Multiplex PWM 4 to OUT_D ⁽¹⁾
D7	D6	D5	D4	D3	D2	D1	D0	FUNCTION
0	1	0	0	0	1	0	1	Reserved ⁽¹⁾

9.6.19 DRC Control Register (0x46)

Each DRC can be enabled independently using the DRC control register. The DRCs are disabled by default.

Table 22. DRC Control Register (0x46)

D31	D30	D29	D28	D27	D26	D25	D24	FUNCTION
0	0	0	0	0	0	0	0	Reserved ⁽¹⁾
D23	D22	D21	D20	D19	D18	D17	D16	FUNCTION
0	0	0	0	0	0	0	0	Reserved ⁽¹⁾
D15	D14	D13	D12	D11	D10	D9	D8	FUNCTION
0	0	0	0	0	0	0	0	Reserved ⁽¹⁾
D7	D6	D5	D4	D3	D2	D1	D0	FUNCTION
0	0	–	–	–	–	–	–	Reserved ⁽¹⁾
–	–	0	–	–	–	–	–	Disable complementary (1 - H) low-pass filter generation
–	–	1	–	–	–	–	–	Enable complementary (1 - H) low-pass filter generation
–	–	–	0	–	–	–	–	
–	–	–	1	–	–	–	–	
				0	0			Reserved ⁽¹⁾
–	–	–	–	–	–	0	–	DRC2 turned OFF ⁽¹⁾
–	–	–	–	–	–	1	–	DRC2 turned ON
–	–	–	–	–	–	–	0	DRC1 turned OFF ⁽¹⁾
–	–	–	–	–	–	–	1	DRC1 turned ON

(1) Default values are in **bold**.

9.6.20 Bank Switch and EQ Control Register (0x50)
Table 23. Bank Switching Command Register (0x50)

D31	D30	D29	D28	D27	D26	D25	D24	FUNCTION
0	–	–	–	–	–	–	–	32 kHz, does not use bank 3⁽¹⁾
1	–	–	–	–	–	–	–	32 kHz, uses bank 3
–	0	–	–	–	–	–	–	Reserved⁽¹⁾
–	–	0	–	–	–	–	–	Reserved⁽¹⁾
–	–	–	0	–	–	–	–	44.1/48 kHz, does not use bank 3⁽¹⁾
–	–	–	1	–	–	–	–	44.1/48 kHz, uses bank 3
–	–	–	–	0	–	–	–	16 kHz, does not use bank 3
–	–	–	–	1	–	–	–	16 kHz, uses bank 3⁽¹⁾
–	–	–	–	–	0	–	–	22.025/24 kHz, does not use bank 3
–	–	–	–	–	1	–	–	22.025/24 kHz, uses bank 3⁽¹⁾
–	–	–	–	–	–	0	–	8 kHz, does not use bank 3
–	–	–	–	–	–	1	–	8 kHz, uses bank 3⁽¹⁾
–	–	–	–	–	–	–	0	11.025 kHz/12, does not use bank 3
–	–	–	–	–	–	–	1	11.025/12 kHz, uses bank 3⁽¹⁾
D23	D22	D21	D20	D19	D18	D17	D16	FUNCTION
0	–	–	–	–	–	–	–	32 kHz, does not use bank 2⁽¹⁾
1	–	–	–	–	–	–	–	32 kHz, uses bank 2
–	1	–	–	–	–	–	–	Reserved⁽¹⁾
–	–	1	–	–	–	–	–	Reserved⁽¹⁾
–	–	–	0	–	–	–	–	44.1/48 kHz, does not use bank 2
–	–	–	1	–	–	–	–	44.1/48 kHz, uses bank 2⁽¹⁾
–	–	–	–	0	–	–	–	16 kHz, does not use bank 2⁽¹⁾
–	–	–	–	1	–	–	–	16 kHz, uses bank 2
–	–	–	–	–	0	–	–	22.025/24 kHz, does not use bank 2⁽¹⁾
–	–	–	–	–	1	–	–	22.025/24 kHz, uses bank 2
–	–	–	–	–	–	0	–	8 kHz, does not use bank 2⁽¹⁾
–	–	–	–	–	–	1	–	8 kHz, uses bank 2
–	–	–	–	–	–	–	0	11.025/12 kHz, does not use bank 2⁽¹⁾
–	–	–	–	–	–	–	1	11.025/12 kHz, uses bank 2
D15	D14	D13	D12	D11	D10	D9	D8	FUNCTION
0	–	–	–	–	–	–	–	32 kHz, does not use bank 1
1	–	–	–	–	–	–	–	32 kHz, uses bank 1⁽¹⁾
–	0	–	–	–	–	–	–	Reserved⁽¹⁾
–	–	0	–	–	–	–	–	Reserved⁽¹⁾
–	–	–	0	–	–	–	–	44.1/48 kHz, does not use bank 1⁽¹⁾
–	–	–	1	–	–	–	–	44.1/48 kHz, uses bank 1
–	–	–	–	0	–	–	–	16 kHz, does not use bank 1⁽¹⁾
–	–	–	–	1	–	–	–	16 kHz, uses bank 1
–	–	–	–	–	0	–	–	22.025/24 kHz, does not use bank 1⁽¹⁾
–	–	–	–	–	1	–	–	22.025/24 kHz, uses bank 1
–	–	–	–	–	–	0	–	8 kHz, does not use bank 1⁽¹⁾
–	–	–	–	–	–	1	–	8 kHz, uses bank 1
–	–	–	–	–	–	–	0	11.025/12 kHz, does not use bank 1⁽¹⁾
–	–	–	–	–	–	–	1	11.025/12 kHz, uses bank 1

(1) Default values are in **bold**.

Table 23. Bank Switching Command Register (0x50) (continued)

D7	D6	D5	D4	D3	D2	D1	D0	FUNCTION
0								EQ ON
1	–	–	–	–	–	–	–	EQ OFF (bypass BQ 0-7 of channels 1 and 2)
–	0	–	–	–	–	–	–	Reserved ⁽¹⁾
–	–	0	–	–	–	–	–	Ignore bank-mapping in bits D31–D8. Use default mapping. ⁽¹⁾
		1						Use bank-mapping in bits D31–D8.
–	–	–	0	–	–	–	–	L and R can be written independently. ⁽¹⁾
–	–	–	1	–	–	–	–	L and R are ganged for EQ biquads; a write to left-channel BQ is also written to right-channel BQ. (0x29–0x2F is ganged to 0x30–0x36. Also 0x58–0x59 is ganged to 0x5C–0x5D)
–	–	–	–	0	–	–	–	Reserved ⁽¹⁾
–	–	–	–	–	0	0	0	No bank switching. All updates to DAP ⁽¹⁾
–	–	–	–	–	0	0	1	Configure bank 1 (32 kHz by default)
–	–	–	–	–	0	1	0	Configure bank 2 (44.1/48 kHz by default)
–	–	–	–	–	0	1	1	Configure bank 3 (other sample rates by default)
–	–	–	–	–	1	0	0	Automatic bank selection
–	–	–	–	–	1	0	1	Reserved
–	–	–	–	–	1	1	X	Reserved

10 Application and Implementation

NOTE

Information in the following applications sections is not part of the TI component specification, and TI does not warrant its accuracy or completeness. TI's customers are responsible for determining suitability of components for their purposes. Customers should validate and test their design implementation to confirm system functionality.

10.1 Application Information

[Figure 68](#), [Figure 71](#), and [Figure 72](#) highlight the required external components and system level connections for proper operation of the device in several popular use cases.

Each of these configurations can be realized using the Evaluation Modules (EVMs) for the device. These flexible modules allow full evaluation of the device in the most common modes of operation. Any design variation can be supported by TI through schematic and layout reviews. Visit <http://e2e.ti.com> for design assistance and join the audio amplifier discussion forum for additional information.

10.2 Typical Applications

10.2.1 Stereo Bridge Tied Load Application

A stereo system generally refers to a system in which there are two full range speakers without a separate amplifier path for the speakers that reproduce the low-frequency content. In this system, two channels are presented to the amplifier via the digital input signal. These two channels are amplified and then sent to two separate speakers.

Most commonly, the two channels are a pair of signals called a stereo pair, with one channel containing the audio for the left channel and the other channel containing the audio for the right channel.

The Stereo BTL Configuration with Headphone and Line Driver Amplifier application is shown in [Figure 68](#).

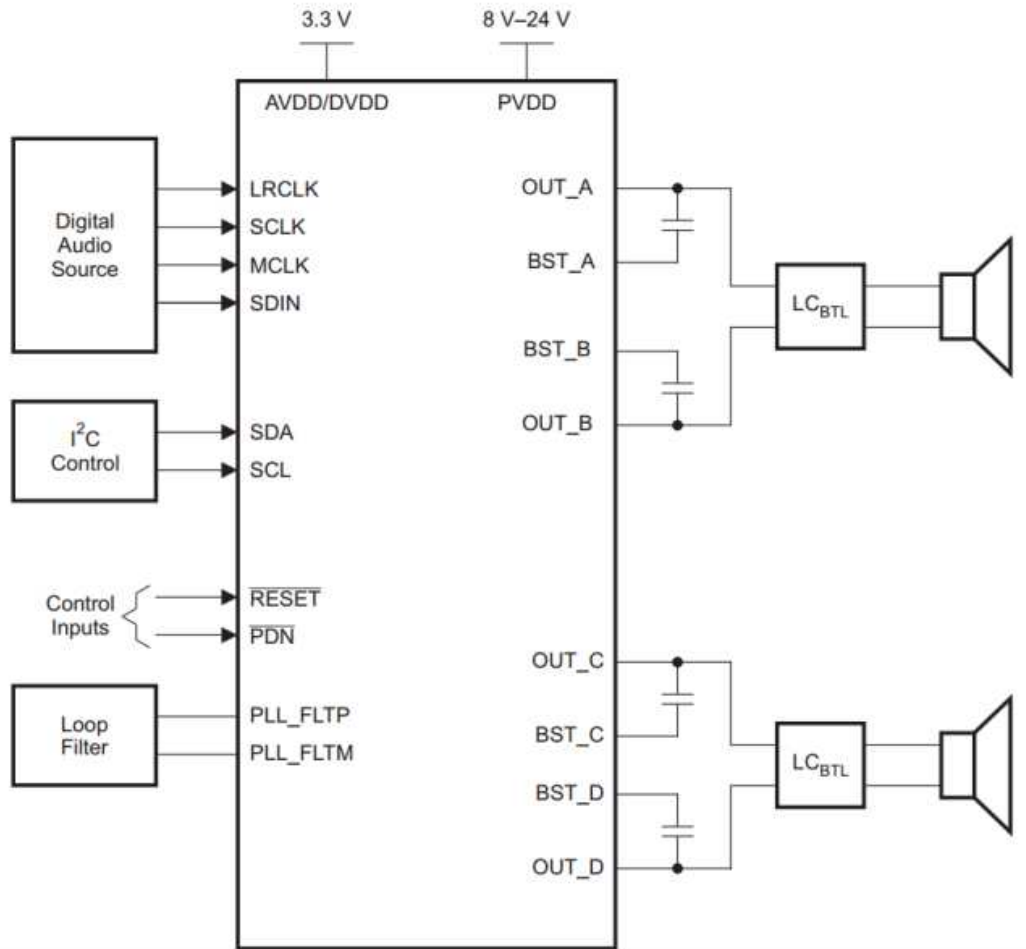
Typical Applications (continued)

Figure 68. Stereo Bridge Tied Load Application
10.2.1.1 Design Requirements
Table 24. Design Requirements

PARAMETER	EXAMPLE
Low Power Supply	3.3 V
High Power Supply	8 V to 24 V
Host Processor	I ² S Compliant Master
	I ² C Compliant Master
	GPIO Control
Output Filters	Inductor-Capacitor Low Pass Filter
Speaker	4 Ω minimum

10.2.1.2 Detailed Design Procedure

10.2.1.2.1 Component Selection and Hardware Connections

The typical connections required for proper operation of the device can be found in the *TAS5731EVM User's Guide* (SLOU331). The device was tested with this list of components; deviation from this list of typical application components, unless recommended by this document, may produce unwanted results, which could range from degradation of audio performance to destructive failure of the device.

10.2.1.2.2 I²C Pullup Resistors

Customary pullup resistors are required on the SCL and SDA signal lines. They are not shown in the Typical Application Circuits, because they are shared by all of the devices on the I²C bus and are considered to be part of the associated passive components for the System Processor. These resistor values must be chosen per the guidance provided in the I²C Specification.

10.2.1.2.3 Digital I/O Connectivity

The digital I/O lines of the TAS5731M are described in previous sections. As discussed, whenever a static digital pin (that is a pin that is hardwired to be HIGH or LOW) is required to be pulled HIGH, it must be connected to DVDD through a pullup resistor to control the slew rate of the voltage presented to the digital I/O pins. It is not, however, necessary to have a separate pullup resistor for each static digital I/O line. Instead, a single resistor can be used to tie all static I/O lines HIGH to reduce BOM count.

10.2.1.2.4 Recommended Start-Up and Shutdown Procedures

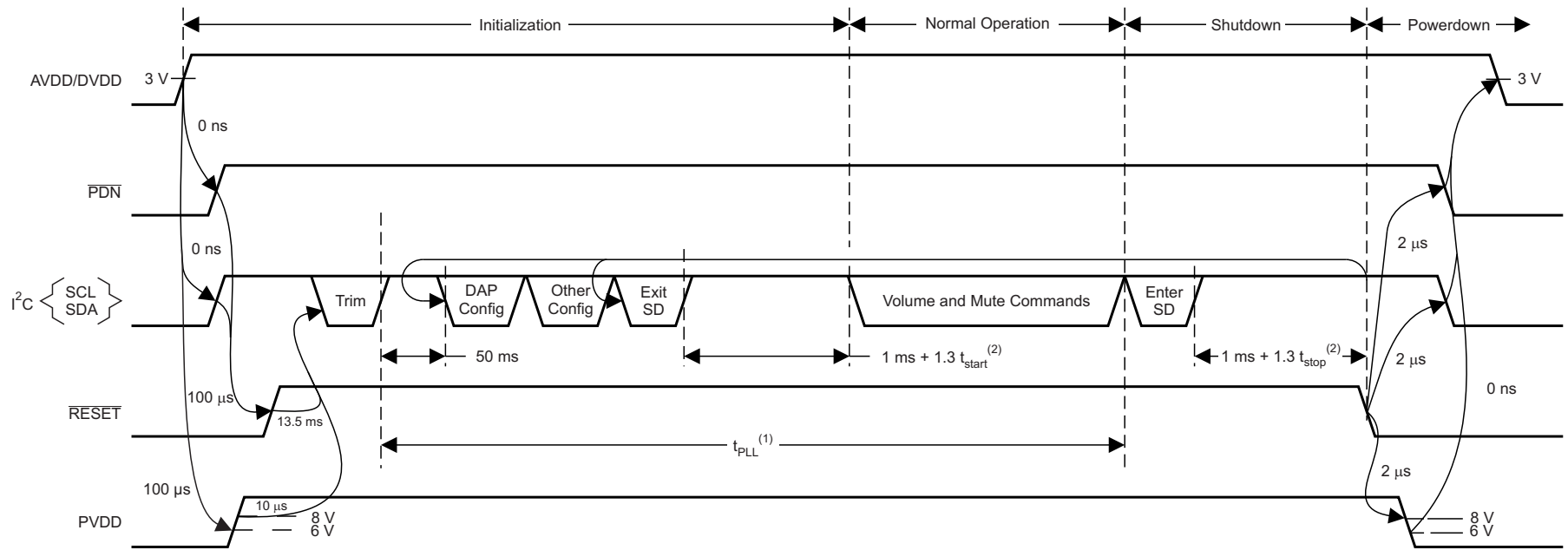

(1) t_{PLL} has to be greater than $240\text{ ms} + 1.3 t_{start}$.
 This constraint only applies to the first trim command following AVDD/DVDD power-up.
 It does not apply to trim commands following subsequent resets.

(2) t_{start}/t_{stop} = PWM start/stop time as defined in register 0X1A

T0419-06

Figure 69. Recommended Command Sequence

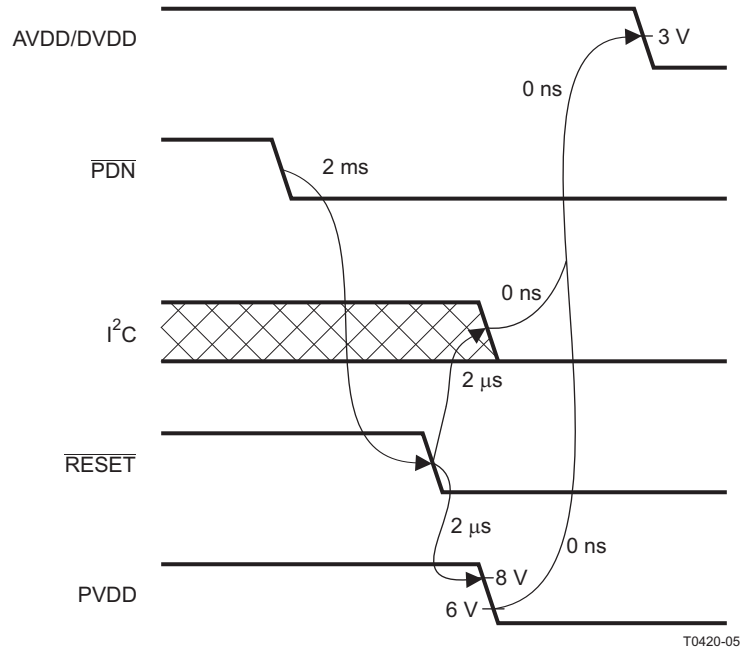

Figure 70. Power-Loss Sequence

10.2.1.2.4.1 Initialization Sequence

Use the following sequence to power up and initialize the device:

1. Hold all digital inputs low and ramp up AVDD/DVDD to at least 3 V.
2. Initialize digital inputs and PVDD supply as follows:
 - Drive $\overline{\text{RESET}} = 0$, $\overline{\text{PDN}} = 1$, and other digital inputs to their desired state while ensuring that all are never more than 2.5 V above AVDD/DVDD. Wait at least 100 μs , drive $\overline{\text{RESET}} = 1$, and wait at least another 13.5 ms.
 - Ramp up PVDD to at least 8 V while ensuring that it remains below 6 V for at least 100 μs after AVDD/DVDD reaches 3 V. Then wait at least another 10 μs .
3. Trim oscillator (write 0x00 to register 0x1B) and wait at least 50 ms.
4. Configure the DAP via I²C, see *TAS5731EVM Evaluation Module User's Guide* (SLOU331) for typical values.
5. Configure remaining registers.
6. Exit shutdown (sequence defined in [Shutdown Sequence](#)).

10.2.1.2.4.2 Normal Operation

The following are the only events supported during normal operation:

1. Writes to master/channel volume registers
2. Writes to soft-mute register
3. Enter and exit shutdown (sequence defined in [Shutdown Sequence](#))

NOTE

Event 3 is not supported for $240 \text{ ms} + 1.3 \times t_{\text{start}}$ after trim following AVDD/DVDD power-up ramp (where t_{start} is specified by register 0x1A).

10.2.1.2.4.3 Shutdown Sequence

Enter:

1. Write 0x40 to register 0x05.
2. Wait at least $1\text{ ms} + 1.3 \times t_{\text{stop}}$ (where t_{stop} is specified by register 0x1A).
3. If desired, reconfigure by returning to step 4 of initialization sequence.

Exit:

1. Write 0x00 to register 0x05 (exit shutdown command may not be serviced for as much as 240 ms after trim following AVDD/DVDD power-up ramp).
2. Wait at least $1\text{ ms} + 1.3 \times t_{\text{start}}$ (where t_{start} is specified by register 0x1A).
3. Proceed with normal operation.

10.2.1.2.4.4 Power-Down Sequence

Use the following sequence to power down the device and its supplies:

1. If time permits, enter shutdown (sequence defined in [Shutdown Sequence](#)); else, in case of sudden power loss, assert $\overline{\text{PDN}} = 0$ and wait at least 2 ms.
2. Assert $\overline{\text{RESET}} = 0$.
3. Drive digital inputs low and ramp down PVDD supply as follows:
 - Drive all digital inputs low after $\overline{\text{RESET}}$ has been low for at least 2 μs .
 - Ramp down PVDD while ensuring that it remains above 8 V until $\overline{\text{RESET}}$ has been low for at least 2 μs .
4. Ramp down AVDD/DVDD while ensuring that it remains above 3 V until PVDD is below 6 V and that it is never more than 2.5 V below the digital inputs.

10.2.1.3 Application Curves

Table 25. Relevant Performance Curves

CURVE TITLE	FIGURE
Output Power vs Supply Voltage (2.0 BTL Mode) With 4 ω Load on Typical 2 Layer PCB Device May Be Thermally Limited Above 20 V	Figure 18
Total Harmonic Distortion + Noise vs Output Power (2.0 BTL Mode)	Figure 19
Total Harmonic Distortion + Noise vs Output Power (2.0 BTL Mode)	Figure 20
Total Harmonic Distortion + Noise vs Output Power (2.0 BTL Mode)	Figure 21
Total Harmonic Distortion vs Frequency (2.0 BTL Mode)	Figure 22
Total Harmonic Distortion vs Frequency (2.0 BTL Mode)	Figure 23
Total Harmonic Distortion vs Frequency (2.0 BTL Mode)	Figure 24
Efficiency vs Output Power (2.0 BTL Mode)	Figure 25
Crosstalk vs Frequency (2.0 BTL Mode)	Figure 26
Crosstalk vs Frequency (2.0 BTL Mode)	Figure 27
Crosstalk vs Frequency (2.0 BTL Mode)	Figure 28
Crosstalk vs Frequency (2.0 BTL Mode)	Figure 29
Power vs Supply Voltage (2.0 BTL Mode)	Figure 30
Idle Channel Noise vs Supply Voltage (2.0 BTL Mode)	Figure 31

10.2.2 Mono Parallel Bridge Tied Load Application

A mono system refers to a system in which the amplifier is used to drive a single loudspeaker. Parallel Bridge Tied Load (PBTTL) indicates that the two full-bridge channels of the device are placed in parallel and drive the loudspeaker simultaneously using an identical audio signal. The primary benefit of operating the TAS5731M device in PBTTL operation is to reduce the power dissipation and increase the current sourcing capabilities of the amplifier output. In this mode of operation, the current limit of the audio amplifier is approximately doubled while the on-resistance is approximately halved.

The loudspeaker can be a full-range transducer or one that only reproduces the low-frequency content of an audio signal, as in the case of a powered subwoofer. Often in this use case, two stereo signals are mixed together and sent through a low-pass filter in order to create a single audio signal which contains the low frequency information of the two channels.

The Mono Parallel Bridge Tied Load application is shown in [Figure 71](#).

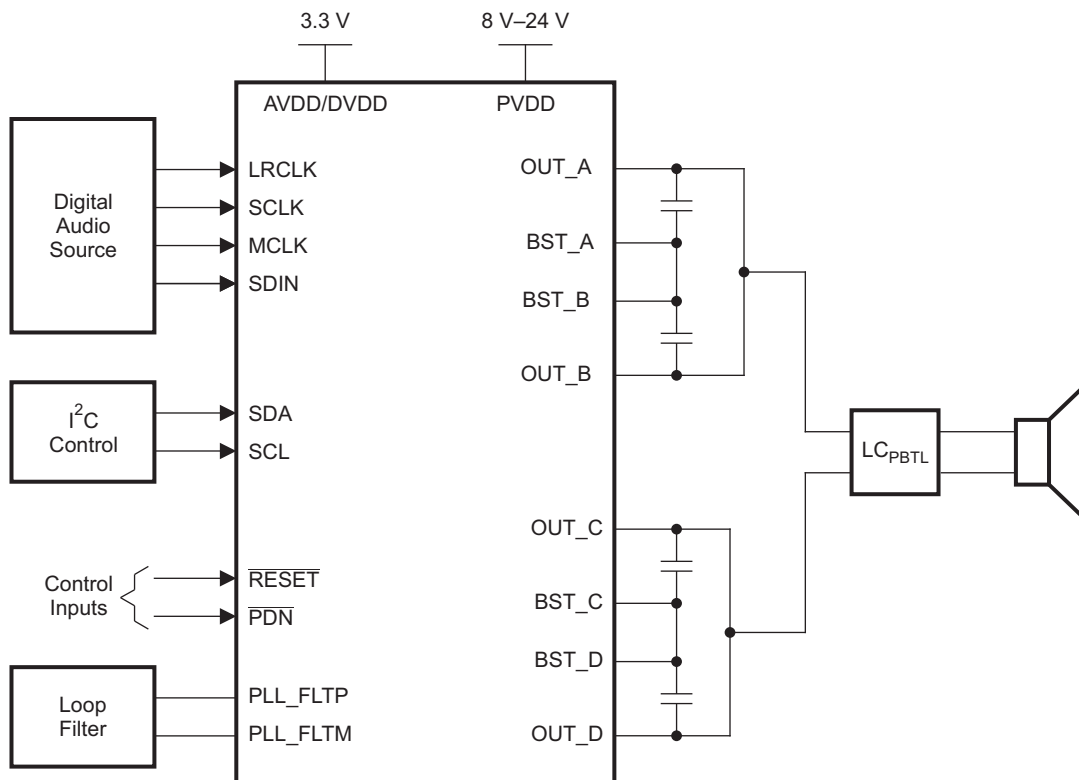

B0264-26

Figure 71. Mono Parallel Bridge Tied Load Application

10.2.2.1 Design Requirements

Table 26. Design Requirements

PARAMETER	EXAMPLE
Low Power Supply	3.3 V
High Power Supply	8 V to 24 V
Host Processor	I ² S Compliant Master
	I ² C Compliant Master
	GPIO Control
Output Filters	Inductor-Capacitor Low Pass Filter
Speaker	4 Ω minimum

10.2.2.2 Detailed Design Procedure

Refer to [Detailed Design Procedure](#) for information.

10.2.2.3 Application Curves

Table 27. Relevant Performance Curves

CURVE TITLE	FIGURE
Output Power vs Supply Voltage (PBTL Mode) With 2 ω Load on Typical 2 Layer PCB, Device May Be Thermally Limited Above 20 V	Figure 32
Total Harmonic Distortion + Noise vs Output Power (PBTL Mode)	Figure 33
Total Harmonic Distortion + Noise vs Output Power (PBTL Mode)	Figure 34
Total Harmonic Distortion + Noise vs Output Power (PBTL Mode)	Figure 35
Total Harmonic Distortion vs Frequency (PBTL Mode)	Figure 36
Total Harmonic Distortion vs Frequency (PBTL Mode)	Figure 37
Total Harmonic Distortion vs Frequency (PBTL Mode)	Figure 38
Efficiency vs Output Power (PBTL Mode)	Figure 39
Efficiency vs Output Power (PBTL Mode)	Figure 40
Power vs Supply Voltage (PBTL Mode)	Figure 41
Idle Channel Noise vs Supply Voltage (PBTL Mode)	Figure 42

10.2.3 2.1 Application

A 2.1 system generally refers to a system in which there are two full range speakers with a separate amplifier path for the speakers which reproduce the low-frequency content. In this system, two channels are presented to the amplifier via the digital input signal, these are driven into two single-ended speakers and are mixed into a third channel, conditioned to stream low-frequency content into a differentially connected speaker.

The 2.1 application is shown in Figure 72.

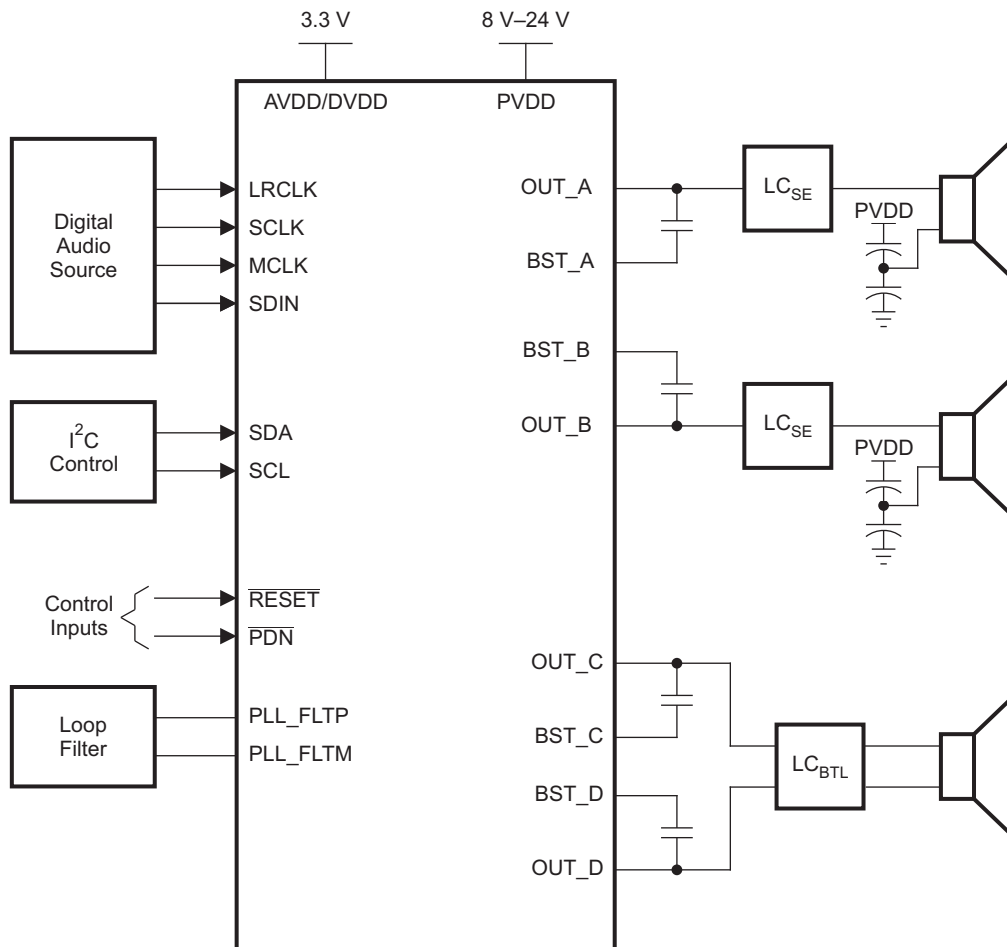

B0264-25

Figure 72. Simplified 2.1 Application Diagram

10.2.3.1 Design Requirements

Table 28. Design Requirements

PARAMETER	EXAMPLE
Low Power Supply	3.3 V
High Power Supply	8 V to 24 V
Host Processor	I ² S Compliant Master
	I ² C Compliant Master
	GPIO Control
Output Filters	Inductor-Capacitor Low Pass Filter
Speaker	4 Ω (BTL), 2 Ω (SE) minimum

10.2.3.2 Detailed Design Procedure

Refer to [Detailed Design Procedure](#) for information.

10.2.3.3 Application Curves

Table 29. Relevant Performance Curves

CURVE TITLE	FIGURE
Output Power vs Supply Voltage (2.1 SE Mode) With 2 × 4 ω + 4 ω Load on Typical 2 Layer PCB Device May Be Thermally Limited Above 20 V	Figure 5
Total Harmonic Distortion + Noise vs Output Power (2.1 SE Mode)	Figure 6
Total Harmonic Distortion + Noise vs Output Power (2.1 SE Mode)	Figure 7
Total Harmonic Distortion + Noise vs Output Power (2.1 SE Mode)	Figure 8
Total Harmonic Distortion + Noise vs Frequency (2.1 SE Mode)	Figure 9
Total Harmonic Distortion + Noise vs Frequency (2.1 SE Mode)	Figure 10
Total Harmonic Distortion + Noise vs Frequency (2.1 SE Mode)	Figure 11
Efficiency vs Total Output Power (2.1 SE Mode)	Figure 12
Efficiency vs Total Output Power (2.1 SE Mode)	Figure 13
Crosstalk vs Frequency (2.1 SE Mode)	Figure 14
Crosstalk vs Frequency (2.1 SE Mode)	Figure 15
Crosstalk vs Frequency (2.1 SE Mode)	Figure 16
Crosstalk vs Frequency (2.1 SE Mode)	Figure 17

11 Power Supply Recommendations

The TAS5731M requires two power supplies; a low voltage 3.3 V nominal for the pins DVDD, AVDD, and DRVDD and a high power supply, 8 V to 24 V for the pin PVDD. There is no requirement for power up sequencing of low and high power supplies, however is recommended to put the PDN pin to low before removing the low voltage power supplies in order to protect the outputs.

11.1 DVDD and AVDD Supplies

The AVDD Supply is used to power the analog internal circuit of the device, and needs a well regulated and filtered 3.3-V supply voltage. The DVDD Supply is used to power the digital circuitry. DVDD needs a well regulated and filtered 3.3-V supply voltage.

11.2 PVDD Power Supply

The TAS5731M class-D audio amplifier requires adequate power supply decoupling to ensure the output total harmonic distortion (THD) and noise is as low as possible. A good low equivalent-series-resistance (ESR) ceramic capacitor, typically 1 μF , placed as close as possible to the device PVDD leads works best. For filtering lower frequency noise signals, a 10 μF or greater capacitor placed near the audio power amplifier is recommended.

12 Layout

12.1 Layout Guidelines

Class-D switching edges are fast and switched currents are high so it is necessary to take care when planning the layout of the printed circuit board. The following suggestions will help to meet audio, thermal and EMC requirements.

- TAS5731M uses the PCB for heat sinking therefore the PowerPAD needs to be soldered to the PCB and adequate copper area and copper vias connecting the top, bottom and internal layers must be used.
- Decoupling capacitors: the high-frequency decoupling capacitors must be placed as close to the supply pins as possible; on the TAS5731M a 1- μF high-quality ceramic capacitor is used. Large (10 μF or greater) bulk power supply decoupling capacitors must be placed near the TAS5731M on the PVDD supplies.
- Keep the current loop from each of the outputs through the output inductor and the small filter cap and back to GND as small and tight as possible. The size of this current loop determines its effectiveness as an antenna.
- Grounding: A big common GND plane is recommended. The PVDD decoupling capacitors must connect to GND. The TAS5731M PowerPAD must be connected to GND.
- Output filter: remember to select inductors that can handle the high short circuit current of the device. The LC filter must be placed close to the outputs.

The EVM product folder ([TAS5731EVM](#)) and User's Guide ([SLOU331](#)) available on [www.ti.com](#) show schematic, bill of material, gerber files, and more detailed layout plots.

12.2 Layout Examples

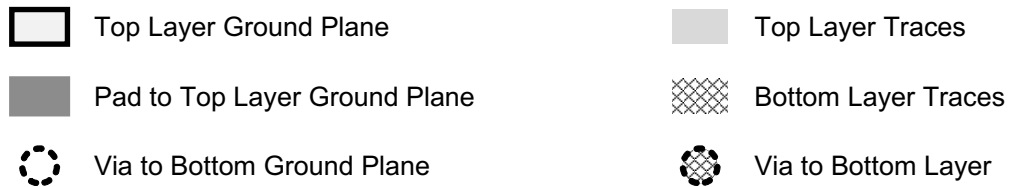
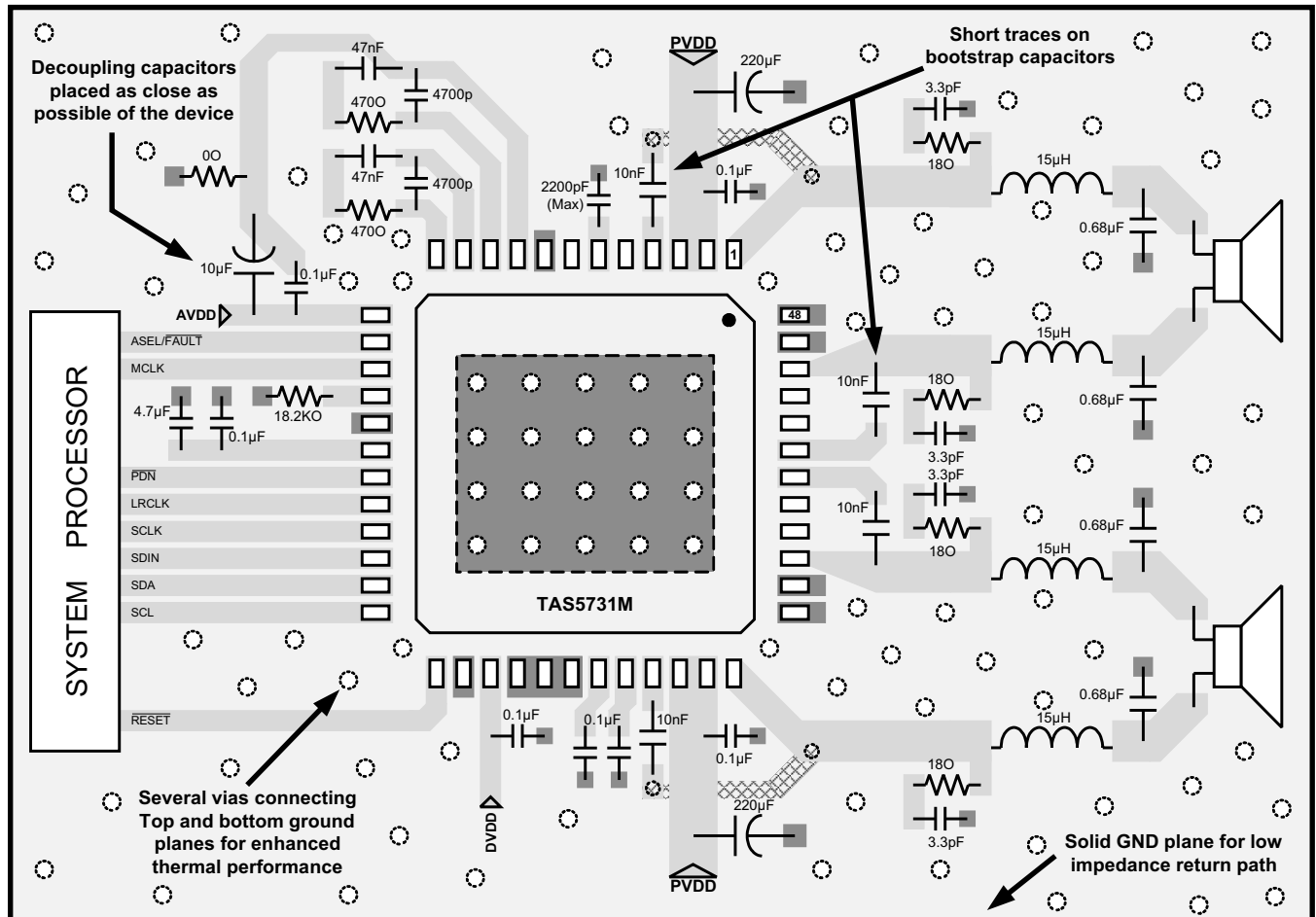
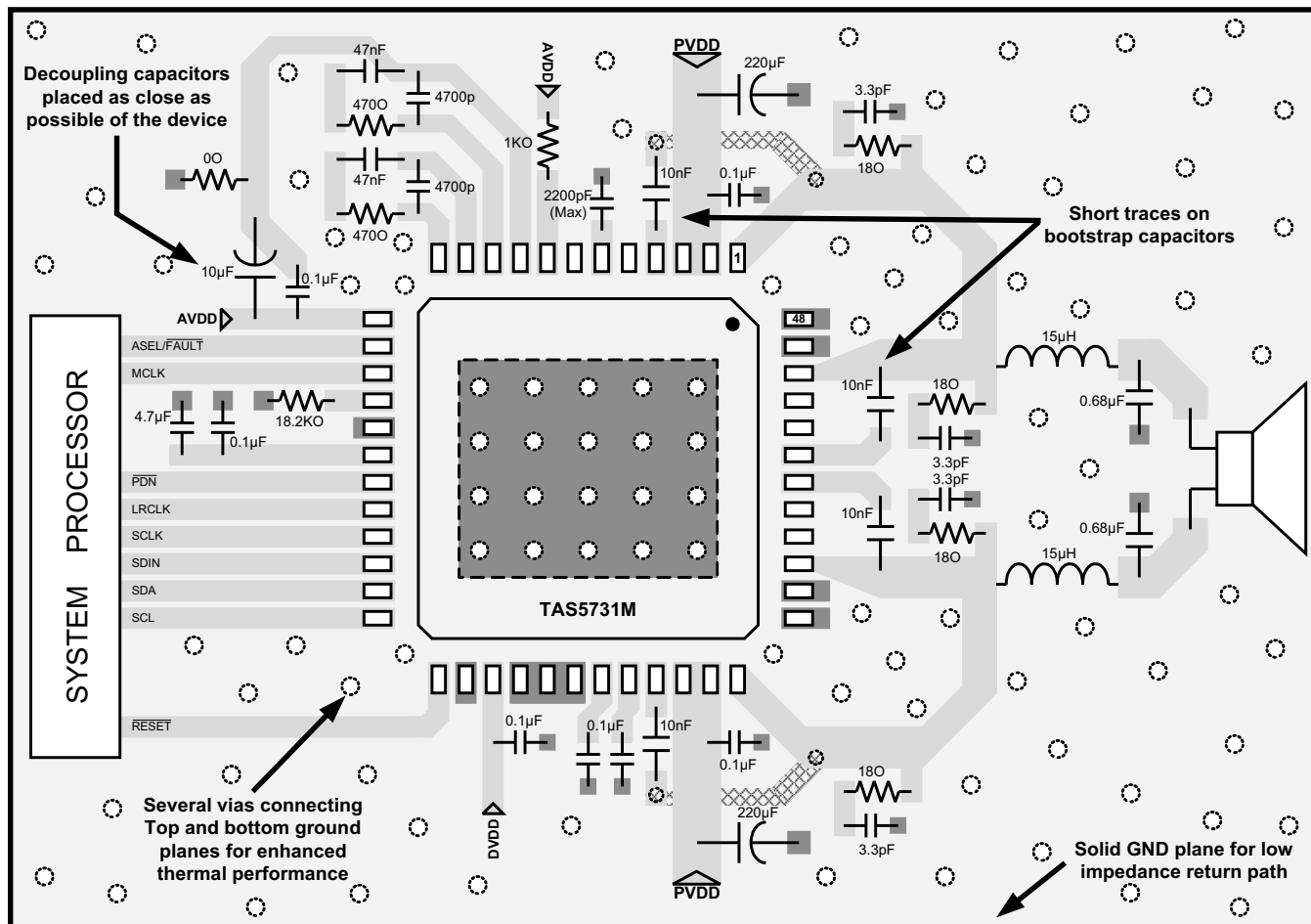

Figure 73. Stereo PBTB Mode

Layout Examples (continued)



- Top Layer Ground Plane
- Top Layer Traces
- Pad to Top Layer Ground Plane
- Bottom Layer Traces
- Via to Bottom Ground Plane
- Via to Bottom Layer

Figure 74. Mono PBTL Mode

TAS5731M

SLOS838C –JULY 2013–REVISED AUGUST 2015

www.ti.com

Layout Examples (continued)

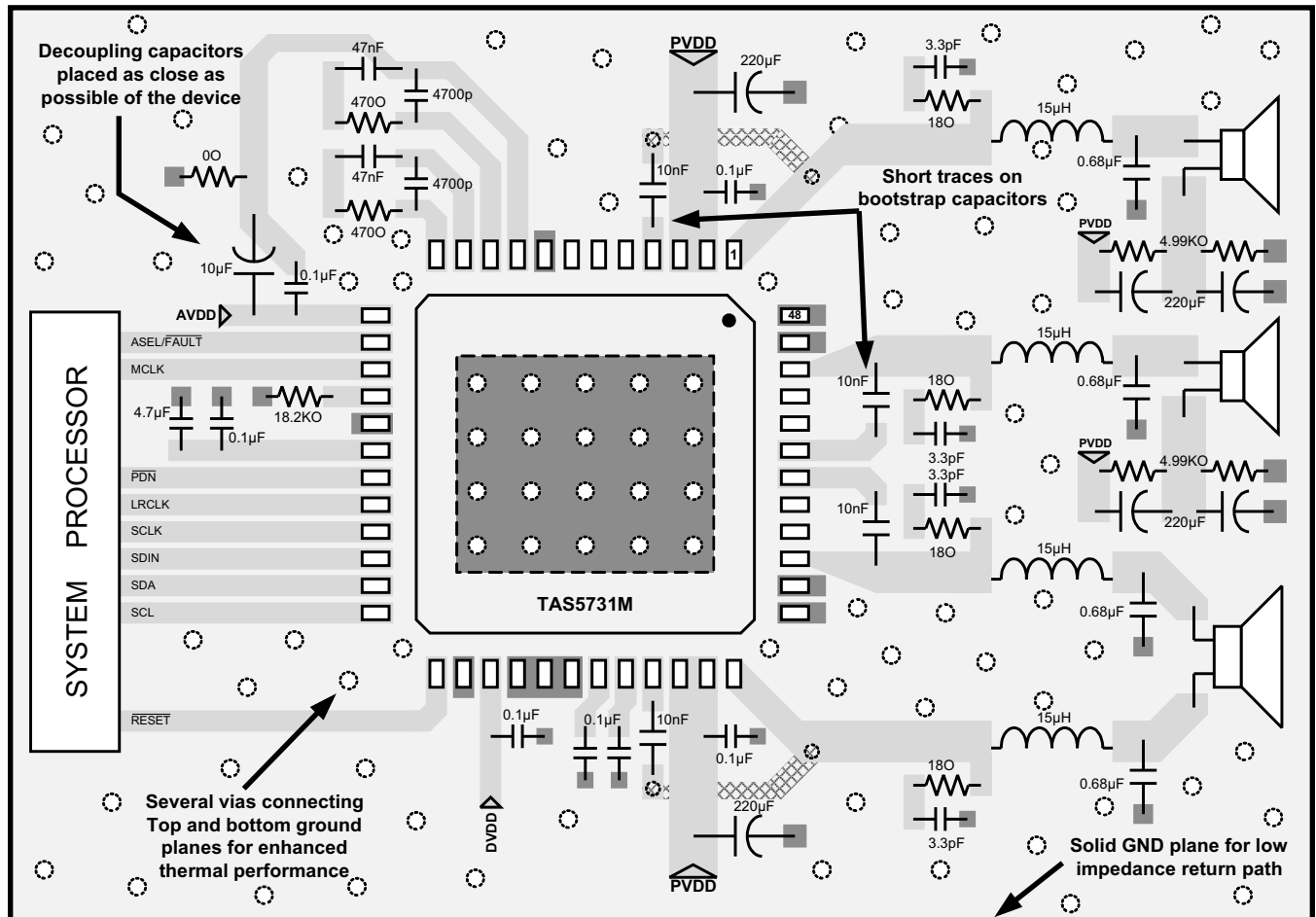

- Top Layer Ground Plane
- Pad to Top Layer Ground Plane
- Bottom Layer Traces
- Via to Bottom Ground Plane
- Via to Bottom Layer
- Top Layer Traces

Figure 75. 2.1 Mode

13 Device and Documentation Support

13.1 Device Support

13.1.1 Third-Party Products Disclaimer

TI'S PUBLICATION OF INFORMATION REGARDING THIRD-PARTY PRODUCTS OR SERVICES DOES NOT CONSTITUTE AN ENDORSEMENT REGARDING THE SUITABILITY OF SUCH PRODUCTS OR SERVICES OR A WARRANTY, REPRESENTATION OR ENDORSEMENT OF SUCH PRODUCTS OR SERVICES, EITHER ALONE OR IN COMBINATION WITH ANY TI PRODUCT OR SERVICE.

13.1.2 Development Support

TAS570X GDE Software Setup development tool documentation ([SLOC124](#))

13.2 Documentation Support

EVM product folder ([TAS5731EVM](#))

13.2.1 Related Documentation

TAS5731 EVM User's Guide ([SLOU331](#))

13.3 Community Resources

The following links connect to TI community resources. Linked contents are provided "AS IS" by the respective contributors. They do not constitute TI specifications and do not necessarily reflect TI's views; see TI's [Terms of Use](#).

TI E2E™ Online Community *TI's Engineer-to-Engineer (E2E) Community*. Created to foster collaboration among engineers. At [e2e.ti.com](#), you can ask questions, share knowledge, explore ideas and help solve problems with fellow engineers.

Design Support *TI's Design Support* Quickly find helpful E2E forums along with design support tools and contact information for technical support.

13.4 Trademarks

PowerPAD, E2E are trademarks of Texas Instruments.
All other trademarks are the property of their respective owners.

13.5 Electrostatic Discharge Caution



These devices have limited built-in ESD protection. The leads should be shorted together or the device placed in conductive foam during storage or handling to prevent electrostatic damage to the MOS gates.

13.6 Glossary

[SLYZ022](#) — *TI Glossary*.

This glossary lists and explains terms, acronyms, and definitions.

14 Mechanical, Packaging, and Orderable Information

The following pages include mechanical, packaging, and orderable information. This information is the most current data available for the designated devices. This data is subject to change without notice and revision of this document. For browser-based versions of this data sheet, refer to the left-hand navigation.

PACKAGING INFORMATION

Orderable Device	Status (1)	Package Type	Package Drawing	Pins	Package Qty	Eco Plan (2)	Lead/Ball Finish (6)	MSL Peak Temp (3)	Op Temp (°C)	Device Marking (4/5)	Samples
TAS5731MPHP	ACTIVE	HTQFP	PHP	48	250	Green (RoHS & no Sb/Br)	CU NIPDAU	Level-3-260C-168 HR	-40 to 85	TAS5731M	Samples
TAS5731MPHPR	ACTIVE	HTQFP	PHP	48	1000	Green (RoHS & no Sb/Br)	CU NIPDAU	Level-3-260C-168 HR	-40 to 85	TAS5731M	Samples

(1) The marketing status values are defined as follows:

ACTIVE: Product device recommended for new designs.

LIFEBUY: TI has announced that the device will be discontinued, and a lifetime-buy period is in effect.

NRND: Not recommended for new designs. Device is in production to support existing customers, but TI does not recommend using this part in a new design.

PREVIEW: Device has been announced but is not in production. Samples may or may not be available.

OBSOLETE: TI has discontinued the production of the device.

(2) Eco Plan - The planned eco-friendly classification: Pb-Free (RoHS), Pb-Free (RoHS Exempt), or Green (RoHS & no Sb/Br) - please check <http://www.ti.com/productcontent> for the latest availability information and additional product content details.

TBD: The Pb-Free/Green conversion plan has not been defined.

Pb-Free (RoHS): TI's terms "Lead-Free" or "Pb-Free" mean semiconductor products that are compatible with the current RoHS requirements for all 6 substances, including the requirement that lead not exceed 0.1% by weight in homogeneous materials. Where designed to be soldered at high temperatures, TI Pb-Free products are suitable for use in specified lead-free processes.

Pb-Free (RoHS Exempt): This component has a RoHS exemption for either 1) lead-based flip-chip solder bumps used between the die and package, or 2) lead-based die adhesive used between the die and leadframe. The component is otherwise considered Pb-Free (RoHS compatible) as defined above.

Green (RoHS & no Sb/Br): TI defines "Green" to mean Pb-Free (RoHS compatible), and free of Bromine (Br) and Antimony (Sb) based flame retardants (Br or Sb do not exceed 0.1% by weight in homogeneous material)

(3) MSL, Peak Temp. - The Moisture Sensitivity Level rating according to the JEDEC industry standard classifications, and peak solder temperature.

(4) There may be additional marking, which relates to the logo, the lot trace code information, or the environmental category on the device.

(5) Multiple Device Markings will be inside parentheses. Only one Device Marking contained in parentheses and separated by a "~" will appear on a device. If a line is indented then it is a continuation of the previous line and the two combined represent the entire Device Marking for that device.

(6) Lead/Ball Finish - Orderable Devices may have multiple material finish options. Finish options are separated by a vertical ruled line. Lead/Ball Finish values may wrap to two lines if the finish value exceeds the maximum column width.

Important Information and Disclaimer: The information provided on this page represents TI's knowledge and belief as of the date that it is provided. TI bases its knowledge and belief on information provided by third parties, and makes no representation or warranty as to the accuracy of such information. Efforts are underway to better integrate information from third parties. TI has taken and continues to take reasonable steps to provide representative and accurate information but may not have conducted destructive testing or chemical analysis on incoming materials and chemicals. TI and TI suppliers consider certain information to be proprietary, and thus CAS numbers and other limited information may not be available for release.

In no event shall TI's liability arising out of such information exceed the total purchase price of the TI part(s) at issue in this document sold by TI to Customer on an annual basis.

TAPE AND REEL INFORMATION

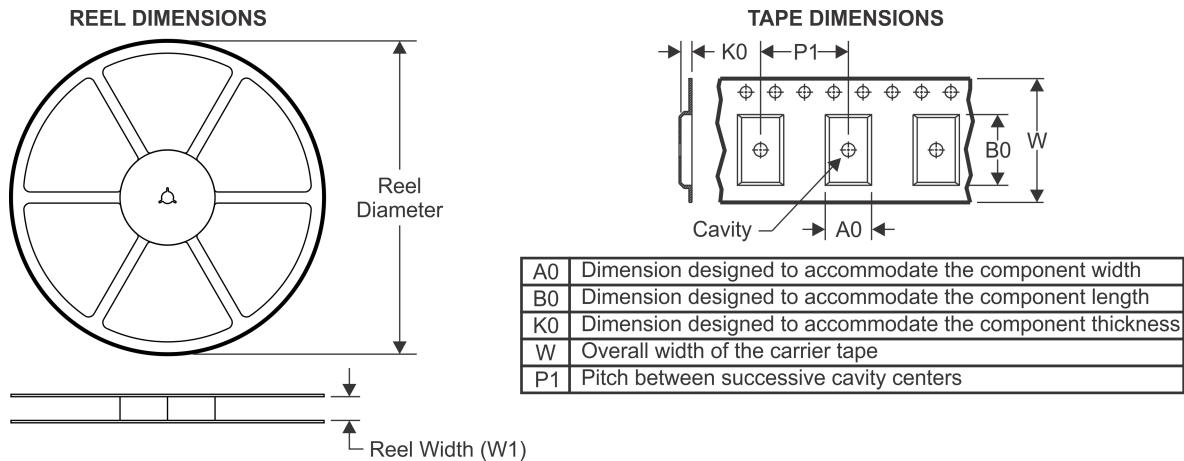

QUADRANT ASSIGNMENTS FOR PIN 1 ORIENTATION IN TAPE

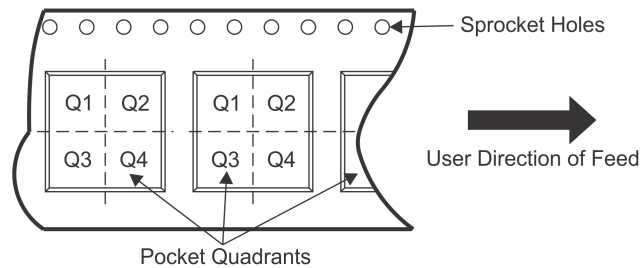

*All dimensions are nominal

Device	Package Type	Package Drawing	Pins	SPQ	Reel Diameter (mm)	Reel Width W1 (mm)	A0 (mm)	B0 (mm)	K0 (mm)	P1 (mm)	W (mm)	Pin1 Quadrant
TAS5731MPHPR	HTQFP	PHP	48	1000	330.0	16.4	9.6	9.6	1.5	12.0	16.0	Q2

TAPE AND REEL BOX DIMENSIONS

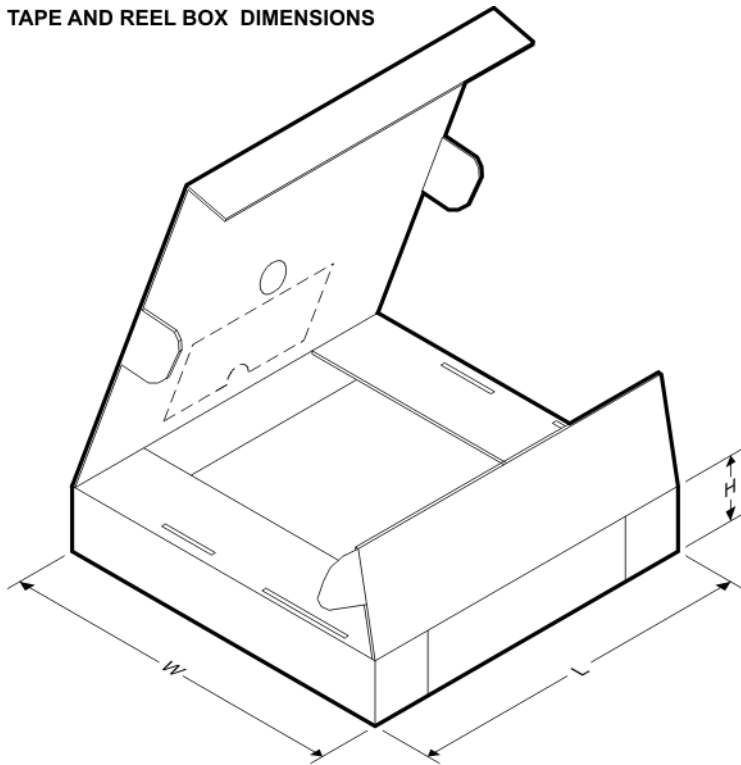

*All dimensions are nominal

Device	Package Type	Package Drawing	Pins	SPQ	Length (mm)	Width (mm)	Height (mm)
TAS5731MPPR	HTQFP	PHP	48	1000	367.0	367.0	38.0

PHP (S-PQFP-G48)

PowerPAD™ PLASTIC QUAD FLATPACK

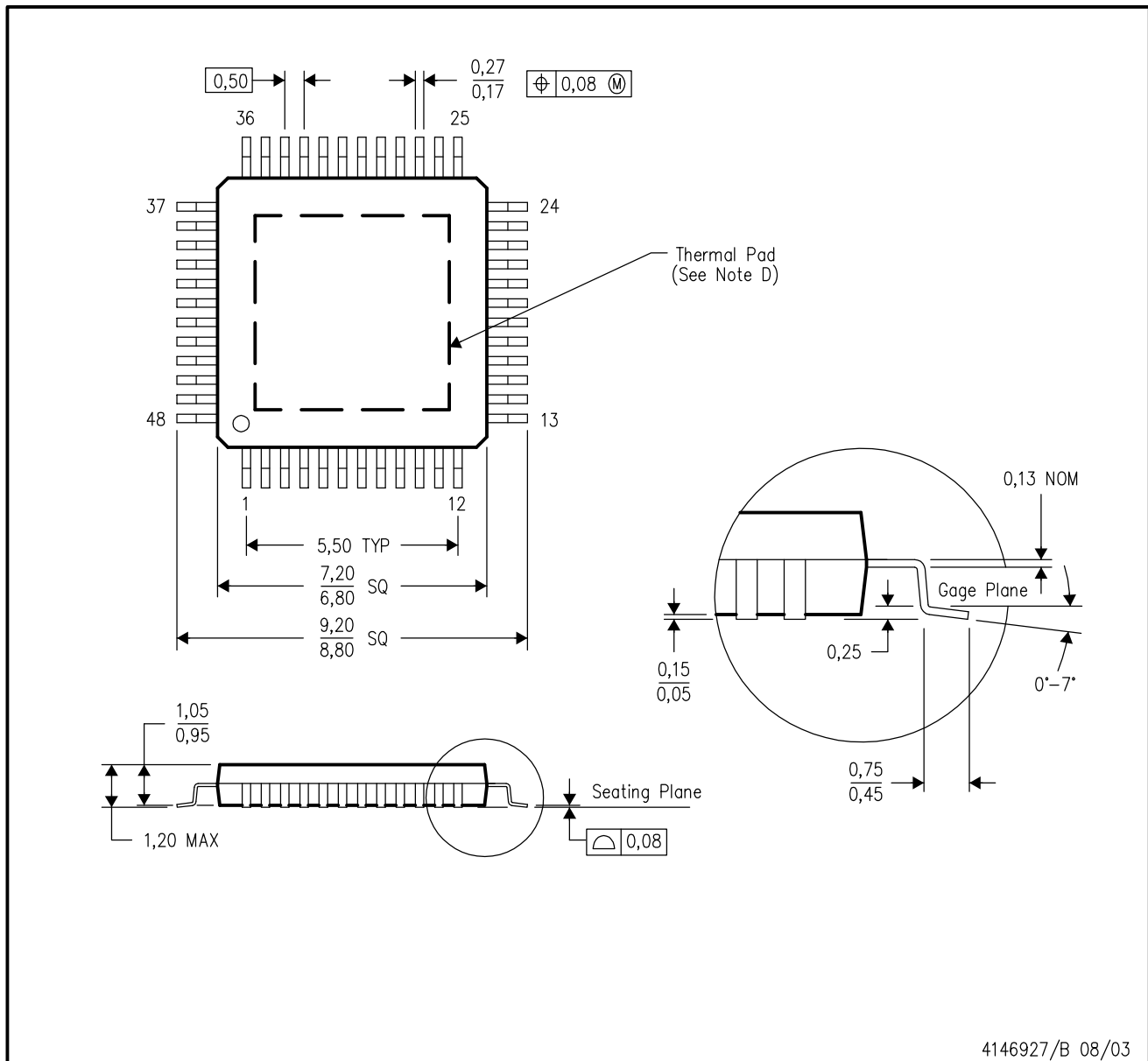

- NOTES:
- All linear dimensions are in millimeters.
 - This drawing is subject to change without notice.
 - Body dimensions do not include mold flash or protrusion.
 - This package is designed to be soldered to a thermal pad on the board. Refer to Technical Brief, PowerPad Thermally Enhanced Package, Texas Instruments Literature No. SLMA002 for information regarding recommended board layout. This document is available at www.ti.com <<http://www.ti.com>>.
 - Falls within JEDEC MS-026

PowerPAD is a trademark of Texas Instruments.

THERMAL PAD MECHANICAL DATA

PHP (S-PQFP-G48)

PowerPAD™ PLASTIC QUAD FLATPACK

THERMAL INFORMATION

This PowerPAD™ package incorporates an exposed thermal pad that is designed to be attached to a printed circuit board (PCB). The thermal pad must be soldered directly to the PCB. After soldering, the PCB can be used as a heatsink. In addition, through the use of thermal vias, the thermal pad can be attached directly to the appropriate copper plane shown in the electrical schematic for the device, or alternatively, can be attached to a special heatsink structure designed into the PCB. This design optimizes the heat transfer from the integrated circuit (IC).

For additional information on the PowerPAD package and how to take advantage of its heat dissipating abilities, refer to Technical Brief, PowerPAD Thermally Enhanced Package, Texas Instruments Literature No. SLMA002 and Application Brief, PowerPAD Made Easy, Texas Instruments Literature No. SLMA004. Both documents are available at www.ti.com.

The exposed thermal pad dimensions for this package are shown in the following illustration.

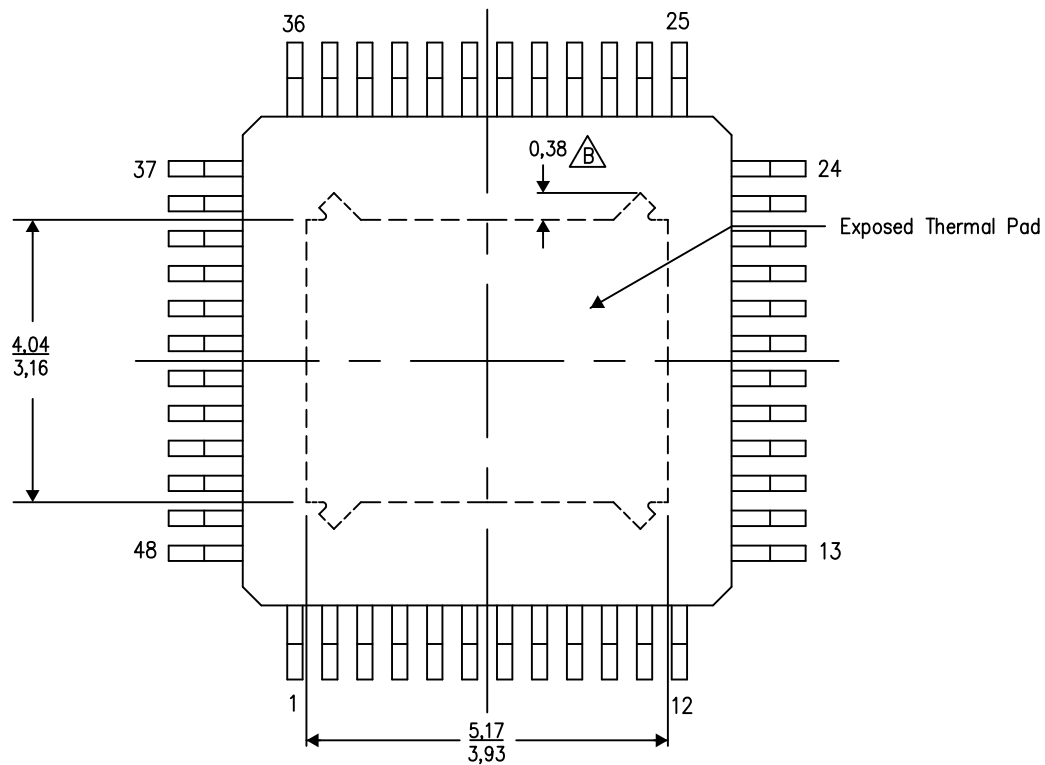

Top View

Exposed Thermal Pad Dimensions

4206329-9/P 03/15

NOTE: A. All linear dimensions are in millimeters

$\triangle B$ Tie strap features may not be present.

PowerPAD is a trademark of Texas Instruments

PHP (S-PQFP-G48)

PowerPAD™ PLASTIC QUAD FLATPACK

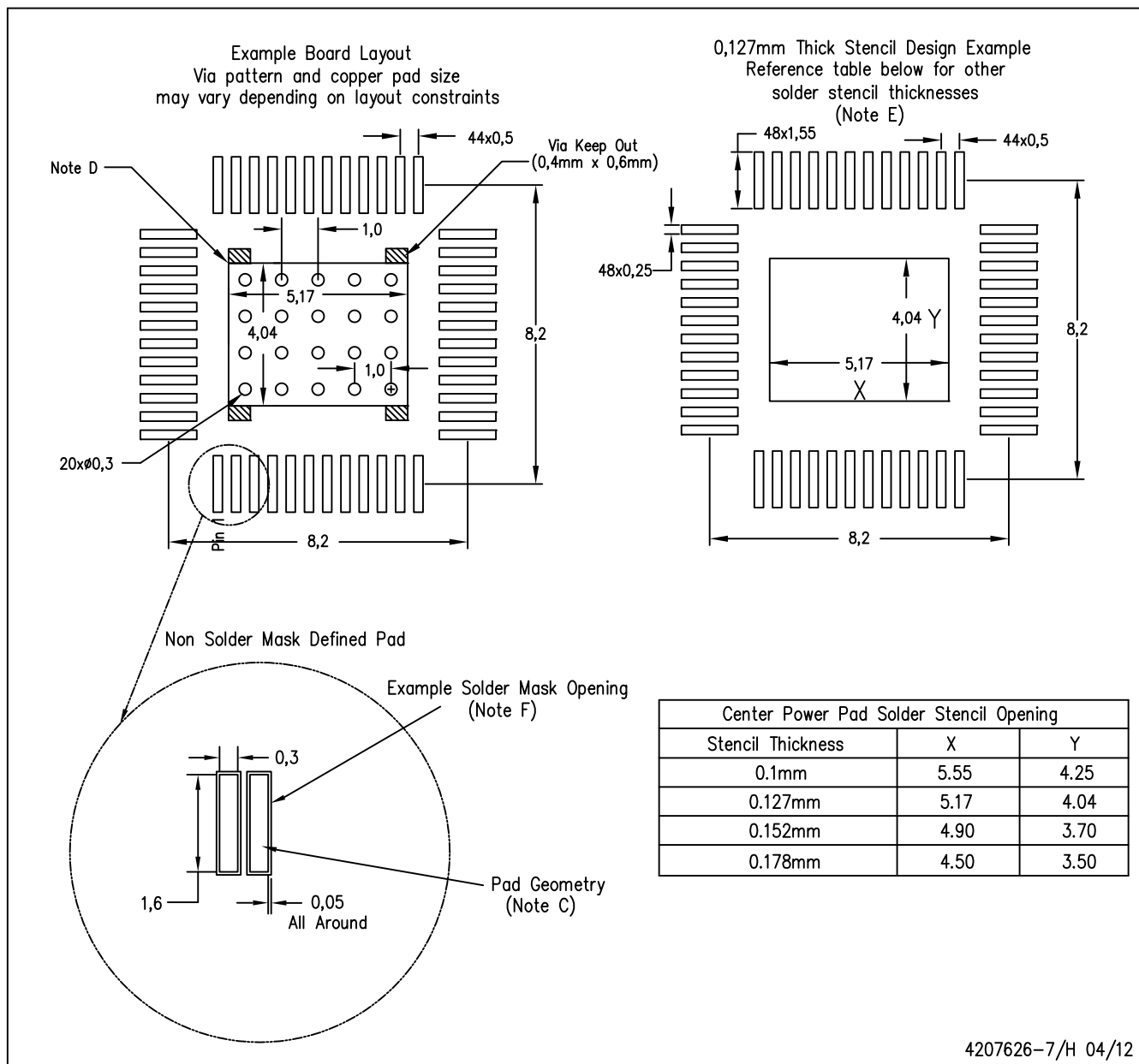

4207626-7/H 04/12

- NOTES:
- A. All linear dimensions are in millimeters.
 - B. This drawing is subject to change without notice.
 - C. Publication IPC-7351 is recommended for alternate designs.
 - D. This package is designed to be soldered to a thermal pad on the board. Refer to Technical Brief, PowerPAD Thermally Enhanced Package, Texas Instruments Literature No. SLMA002, SLMA004, and also the Product Data Sheets for specific thermal information, via requirements, and recommended board layout. These documents are available at www.ti.com <<http://www.ti.com>>.
 - E. Laser cutting apertures with trapezoidal walls and also rounding corners will offer better paste release. Customers should contact their board assembly site for stencil design recommendations. Refer to IPC 7525 for stencil design considerations.
 - F. Customers should contact their board fabrication site for recommended solder mask tolerances and via tenting options for vias placed in the thermal pad.

PowerPAD is a trademark of Texas Instruments

IMPORTANT NOTICE

Texas Instruments Incorporated and its subsidiaries (TI) reserve the right to make corrections, enhancements, improvements and other changes to its semiconductor products and services per JESD46, latest issue, and to discontinue any product or service per JESD48, latest issue. Buyers should obtain the latest relevant information before placing orders and should verify that such information is current and complete. All semiconductor products (also referred to herein as "components") are sold subject to TI's terms and conditions of sale supplied at the time of order acknowledgment.

TI warrants performance of its components to the specifications applicable at the time of sale, in accordance with the warranty in TI's terms and conditions of sale of semiconductor products. Testing and other quality control techniques are used to the extent TI deems necessary to support this warranty. Except where mandated by applicable law, testing of all parameters of each component is not necessarily performed.

TI assumes no liability for applications assistance or the design of Buyers' products. Buyers are responsible for their products and applications using TI components. To minimize the risks associated with Buyers' products and applications, Buyers should provide adequate design and operating safeguards.

TI does not warrant or represent that any license, either express or implied, is granted under any patent right, copyright, mask work right, or other intellectual property right relating to any combination, machine, or process in which TI components or services are used. Information published by TI regarding third-party products or services does not constitute a license to use such products or services or a warranty or endorsement thereof. Use of such information may require a license from a third party under the patents or other intellectual property of the third party, or a license from TI under the patents or other intellectual property of TI.

Reproduction of significant portions of TI information in TI data books or data sheets is permissible only if reproduction is without alteration and is accompanied by all associated warranties, conditions, limitations, and notices. TI is not responsible or liable for such altered documentation. Information of third parties may be subject to additional restrictions.

Resale of TI components or services with statements different from or beyond the parameters stated by TI for that component or service voids all express and any implied warranties for the associated TI component or service and is an unfair and deceptive business practice. TI is not responsible or liable for any such statements.

Buyer acknowledges and agrees that it is solely responsible for compliance with all legal, regulatory and safety-related requirements concerning its products, and any use of TI components in its applications, notwithstanding any applications-related information or support that may be provided by TI. Buyer represents and agrees that it has all the necessary expertise to create and implement safeguards which anticipate dangerous consequences of failures, monitor failures and their consequences, lessen the likelihood of failures that might cause harm and take appropriate remedial actions. Buyer will fully indemnify TI and its representatives against any damages arising out of the use of any TI components in safety-critical applications.

In some cases, TI components may be promoted specifically to facilitate safety-related applications. With such components, TI's goal is to help enable customers to design and create their own end-product solutions that meet applicable functional safety standards and requirements. Nonetheless, such components are subject to these terms.

No TI components are authorized for use in FDA Class III (or similar life-critical medical equipment) unless authorized officers of the parties have executed a special agreement specifically governing such use.

Only those TI components which TI has specifically designated as military grade or "enhanced plastic" are designed and intended for use in military/aerospace applications or environments. Buyer acknowledges and agrees that any military or aerospace use of TI components which have **not** been so designated is solely at the Buyer's risk, and that Buyer is solely responsible for compliance with all legal and regulatory requirements in connection with such use.

TI has specifically designated certain components as meeting ISO/TS16949 requirements, mainly for automotive use. In any case of use of non-designated products, TI will not be responsible for any failure to meet ISO/TS16949.

Products

Audio	www.ti.com/audio
Amplifiers	amplifier.ti.com
Data Converters	dataconverter.ti.com
DLP® Products	www.dlp.com
DSP	dsp.ti.com
Clocks and Timers	www.ti.com/clocks
Interface	interface.ti.com
Logic	logic.ti.com
Power Mgmt	power.ti.com
Microcontrollers	microcontroller.ti.com
RFID	www.ti-rfid.com
OMAP Applications Processors	www.ti.com/omap
Wireless Connectivity	www.ti.com/wirelessconnectivity

Applications

Automotive and Transportation	www.ti.com/automotive
Communications and Telecom	www.ti.com/communications
Computers and Peripherals	www.ti.com/computers
Consumer Electronics	www.ti.com/consumer-apps
Energy and Lighting	www.ti.com/energy
Industrial	www.ti.com/industrial
Medical	www.ti.com/medical
Security	www.ti.com/security
Space, Avionics and Defense	www.ti.com/space-avionics-defense
Video and Imaging	www.ti.com/video

TI E2E Community

e2e.ti.com