

# TCA6416 Low-Voltage 16-Bit I<sup>2</sup>C and SMBus I/O Expander With Interrupt Output, Reset, and Configuration Registers

*Not Recommended for New Designs*

## 1 Features

- Operating Power-Supply Voltage Range of 1.65 V to 5.5 V
- Allows Bidirectional Voltage-Level Translation and GPIO Expansion Between:
  - 1.8-V SCL/SDA and 1.8-V, 2.5-V, 3.3-V, or 5-V P Port
  - 2.5-V SCL/SDA and 1.8-V, 2.5-V, 3.3-V, or 5-V P Port
  - 3.3-V SCL/SDA and 1.8-V, 2.5-V, 3.3-V, or 5-V P Port
  - 5-V SCL/SDA and 1.8-V, 2.5-V, 3.3-V, or 5-V P Port
- I<sup>2</sup>C to Parallel Port Expander
- Low Standby Current Consumption of 1  $\mu$ A
- Schmitt-Trigger Action Allows Slow Input Transition and Better Switching Noise Immunity at the SCL and SDA Inputs
  - $V_{hys} = 0.18$  V Typ at 1.8 V
  - $V_{hys} = 0.25$  V Typ at 2.5 V
  - $V_{hys} = 0.33$  V Typ at 3.3 V
  - $V_{hys} = 0.5$  V Typ at 5 V
- 5-V Tolerant I/O Ports
- Active-Low Reset ( $\overline{\text{RESET}}$ ) Input
- Open-Drain Active-Low Interrupt ( $\overline{\text{INT}}$ ) Output
- 400-kHz Fast I<sup>2</sup>C Bus
- Input/Output Configuration Register

- Polarity Inversion Register
- Internal Power-On Reset
- Power Up With All Channels Configured as Inputs
- No Glitch On Power Up
- Noise Filter on SCL/SDA Inputs
- Latched Outputs With High-Current Drive Maximum Capability for Directly Driving LEDs
- Latch-Up Performance Exceeds 100 mA Per JESD 78, Class II
- ESD Protection Exceeds JESD 22
  - 2000-V Human-Body Model (A114-A)
  - 200-V Machine Model (A115-A)
  - 1000-V Charged-Device Model (C101)

## 2 Description

This 16-bit I/O expander for the two-line bidirectional bus (I<sup>2</sup>C) is designed to provide general-purpose remote I/O expansion for most microcontroller families via the I<sup>2</sup>C interface [serial clock (SCL) and serial data (SDA)].

### Device Information<sup>(1)</sup>

PART NUMBER	PACKAGE	BODY SIZE (NOM)
TCA6416	TSSOP (24)	7.80 mm x 4.40 mm
	WQFN (24)	4.00 mm x 4.00 mm
	BGA (24)	3.00 mm x 3.00 mm

(1) For all available packages, see the orderable addendum at the end of the datasheet.

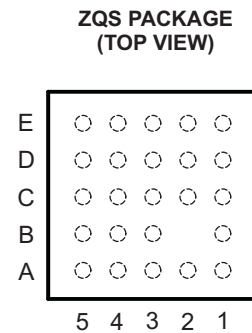
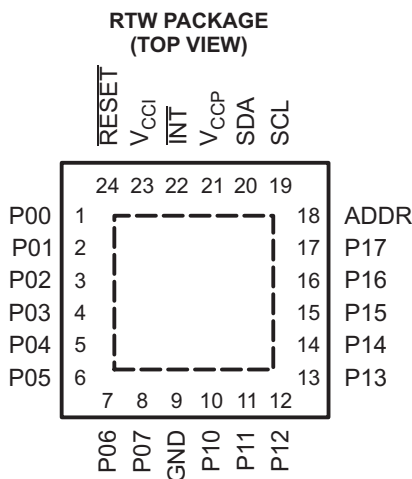
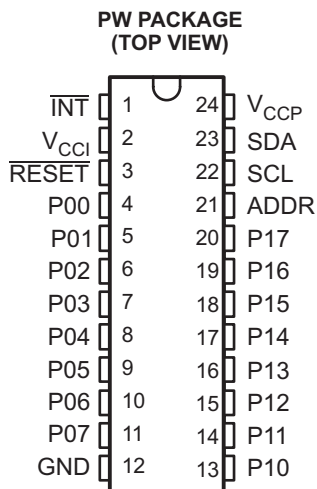

## Table of Contents

<b>1 Features</b> .....	<b>1</b>	<b>7 Parameter Measurement Information</b> .....	<b>11</b>
<b>2 Description</b> .....	<b>1</b>	<b>8 Detailed Description</b> .....	<b>15</b>
<b>3 Revision History</b> .....	<b>2</b>	8.1 Functional Block Diagram .....	<b>15</b>
<b>4 Description (Continued)</b> .....	<b>3</b>	8.2 Device Functional Modes.....	<b>17</b>
<b>5 Pin Configuration And Functions</b> .....	<b>4</b>	8.3 Programming.....	<b>19</b>
<b>6 Specifications</b> .....	<b>5</b>	<b>9 Application And Implementation</b> .....	<b>25</b>
6.1 Absolute Maximum Ratings .....	<b>5</b>	9.1 Typical Application .....	<b>25</b>
6.2 Handling Ratings .....	<b>5</b>	<b>10 Power Supply Recommendations</b> .....	<b>27</b>
6.3 Recommended Operating Conditions.....	<b>5</b>	10.1 Power-On Reset Requirements .....	<b>27</b>
6.4 Electrical Characteristics.....	<b>6</b>	<b>11 Device and Documentation Support</b> .....	<b>29</b>
6.5 I <sup>2</sup> C Interface Timing Requirements.....	<b>7</b>	11.1 Trademarks .....	<b>29</b>
6.6 Reset Timing Requirements .....	<b>7</b>	11.2 Electrostatic Discharge Caution.....	<b>29</b>
6.7 Switching Characteristics .....	<b>7</b>	11.3 Glossary.....	<b>29</b>
6.8 Typical Characteristics.....	<b>8</b>	<b>12 Mechanical, Packaging, and Orderable Information</b> .....	<b>29</b>

## 3 Revision History

Changes from Revision A (February 2009) to Revision B	Page
• Added <b>RESET</b> Errata section .....	<b>17</b>
• Added Interrupt Errata section .....	<b>18</b>

## 4 Description (Continued)

The major benefit of this device is its wide  $V_{CC}$  range. It can operate from 1.65 V to 5.5 V on the P-port side and on the SDA/SCL side. This allows the TCA6416 to interface with next-generation microprocessors and microcontrollers on the SDA/SCL side, where supply levels are dropping down to conserve power. In contrast to the dropping power supplies of microprocessors and microcontrollers, some PCB components, such as LEDs, remain at a 5-V power supply.

The bidirectional voltage level translation in the TCA6416 is provided through  $V_{CCI}$ .  $V_{CCI}$  should be connected to the  $V_{CC}$  of the external SCL/SDA lines. This indicates the  $V_{CC}$  level of the I<sup>2</sup>C bus to the TCA6416. The voltage level on the P-port of the TCA6416 is determined by the  $V_{CCP}$ .

The TCA6416 consists of two 8-bit Configuration (input or output selection), Input, Output, and Polarity Inversion (active high) registers. At power on, the I/Os are configured as inputs. However, the system master can enable the I/Os as either inputs or outputs by writing to the I/O configuration bits. The data for each input or output is kept in the corresponding input or output register. The polarity of the Input Port register can be inverted with the Polarity Inversion register. All registers can be read by the system master.

The system master can reset the TCA6416 in the event of a timeout or other improper operation by asserting a low in the  $\overline{RESET}$  input. The power-on reset puts the registers in their default state and initializes the I<sup>2</sup>C/SMBus state machine. The  $\overline{RESET}$  pin causes the same reset/initialization to occur without depowering the part.

The TCA6416 open-drain interrupt ( $\overline{INT}$ ) output is activated when any input state differs from its corresponding Input Port register state and is used to indicate to the system master that an input state has changed.

$\overline{INT}$  can be connected to the interrupt input of a microcontroller. By sending an interrupt signal on this line, the remote I/O can inform the microcontroller if there is incoming data on its ports without having to communicate via the I<sup>2</sup>C bus. Thus, the TCA6416 can remain a simple slave device.

The device P-port outputs have high-current sink capabilities for directly driving LEDs while consuming low device current.

One hardware pin (ADDR) can be used to program and vary the fixed I<sup>2</sup>C address and allow up to two devices to share the same I<sup>2</sup>C bus or SMBus.

## 5 Pin Configuration And Functions

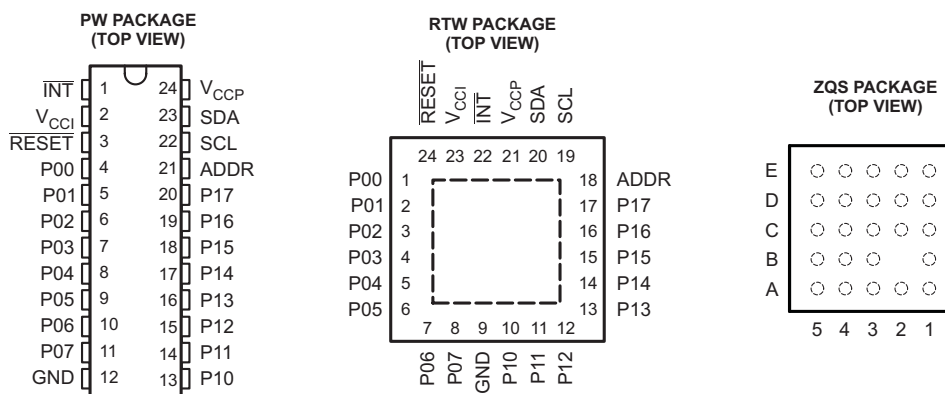

### Pin Functions

NAME	PIN NO.			DESCRIPTION
	TSSOP (PW)	QFN (RTW)	BGA (ZQS)	
$\overline{\text{INT}}$	1	22	A3	Interrupt output. Connect to $V_{\text{CCI}}$ or $V_{\text{CCP}}$ through a pullup resistor.
$V_{\text{CCI}}$	2	23	B3	Supply voltage of I <sup>2</sup> C bus. Connect directly to the $V_{\text{CC}}$ of the external I <sup>2</sup> C master. Provides voltage-level translation.
$\overline{\text{RESET}}$	3	24	A2	Active-low reset input. Connect to $V_{\text{CCP}}$ through a pullup resistor, if no active connection is used.
P00	4	1	A1	P-port input/output (push-pull design structure). At power on, P00 is configured as an input.
P01	5	2	C3	P-port input/output (push-pull design structure). At power on, P01 is configured as an input.
P02	6	3	B1	P-port input/output (push-pull design structure). At power on, P02 is configured as an input.
P03	7	4	C1	P-port input/output (push-pull design structure). At power on, P03 is configured as an input.
P04	8	5	C2	P-port input/output (push-pull design structure). At power on, P04 is configured as an input.
P05	9	6	D1	P-port input/output (push-pull design structure). At power on, P05 is configured as an input.
P06	10	7	E1	P-port input/output (push-pull design structure). At power on, P06 is configured as an input.
P07	11	8	D2	P-port input/output (push-pull design structure). At power on, P07 is configured as an input.
GND	12	9	E2	Ground
P10	13	10	E3	P-port input/output (push-pull design structure). At power on, P10 is configured as an input.
P11	14	11	E4	P-port input/output (push-pull design structure). At power on, P11 is configured as an input.
P12	15	12	D3	P-port input/output (push-pull design structure). At power on, P12 is configured as an input.
P13	16	13	E5	P-port input/output (push-pull design structure). At power on, P13 is configured as an input.
P14	17	14	D4	P-port input/output (push-pull design structure). At power on, P14 is configured as an input.
P15	18	15	D5	P-port input/output (push-pull design structure). At power on, P15 is configured as an input.
P16	19	16	C5	P-port input/output (push-pull design structure). At power on, P16 is configured as an input.
P17	20	17	C4	P-port input/output (push-pull design structure). At power on, P17 is configured as an input.
ADDR	21	18	B5	Address input. Connect directly to $V_{\text{CCP}}$ or ground.
SCL	22	19	A5	Serial clock bus. Connect to $V_{\text{CCI}}$ through a pullup resistor.
SDA	23	20	A4	Serial data bus. Connect to $V_{\text{CCI}}$ through a pullup resistor.
$V_{\text{CCP}}$	24	21	B4	Supply voltage of TCA6416 for P port

## 6 Specifications

### 6.1 Absolute Maximum Ratings<sup>(1)</sup>

over operating free-air temperature range (unless otherwise noted)

				MIN	MAX	UNIT
V <sub>CCI</sub>	Supply voltage range			-0.5	6.5	V
V <sub>CCP</sub>	Supply voltage range			-0.5	6.5	V
V <sub>I</sub>	Input voltage range <sup>(2)</sup>			-0.5	6.5	V
V <sub>O</sub>	Output voltage range <sup>(2)</sup>			-0.5	6.5	V
I <sub>IK</sub>	Input clamp current	ADDR, $\overline{\text{RESET}}$ , SCL	V <sub>I</sub> < 0			±20 mA
I <sub>OK</sub>	Output clamp current	$\overline{\text{INT}}$	V <sub>O</sub> < 0			±20 mA
I <sub>IOK</sub>	Input/output clamp current	P port	V <sub>O</sub> < 0 or V <sub>O</sub> > V <sub>CCP</sub>			±20 mA
		SDA	V <sub>O</sub> < 0 or V <sub>O</sub> > V <sub>CCI</sub>			
I <sub>OL</sub>	Continuous output low current	P port	V <sub>O</sub> = 0 to V <sub>CCP</sub>			25 mA
		SDA, $\overline{\text{INT}}$	V <sub>O</sub> = 0 to V <sub>CCI</sub>			
I <sub>OH</sub>	Continuous output high current	P port	V <sub>O</sub> = 0 to V <sub>CCP</sub>			25 mA
I <sub>CC</sub>	Continuous current through GND					200 mA
	Continuous current through V <sub>CCP</sub>					160 mA
	Continuous current through V <sub>CCI</sub>					10 mA

- (1) Stresses beyond those listed under *Absolute Maximum Ratings* may cause permanent damage to the device. These are stress ratings only, and functional operation of the device at these or any other conditions beyond those indicated under *Recommended Operating Conditions* is not implied. Exposure to absolute-maximum-rated conditions for extended periods may affect device reliability.
- (2) The input negative-voltage and output voltage ratings may be exceeded if the input and output current ratings are observed.

### 6.2 Handling Ratings

				MIN	MAX	UNIT
T <sub>stg</sub>	Storage temperature range			-65	150	°C
V <sub>(ESD)</sub>	Electrostatic discharge	Human body model (HBM), per ANSI/ESDA/JEDEC JS-001, all pins <sup>(1)</sup>		0	2000	V
		Charged device model (CDM), per JEDEC specification JESD22-C101, all pins <sup>(2)</sup>		0	1000	

- (1) JEDEC document JEP155 states that 500-V HBM allows safe manufacturing with a standard ESD control process.
- (2) JEDEC document JEP157 states that 250-V CDM allows safe manufacturing with a standard ESD control process.

### 6.3 Recommended Operating Conditions

				MIN	MAX	UNIT
V <sub>CCI</sub>	Supply voltage			1.65	5.5	V
V <sub>CCP</sub>	Supply voltage			1.65	5.5	
V <sub>IH</sub>	High-level input voltage	SCL, SDA		0.7 × V <sub>CCI</sub>	5.5	V
		ADDR, P17–P00, $\overline{\text{RESET}}$		0.7 × V <sub>CCP</sub>	5.5	
V <sub>IL</sub>	Low-level input voltage	SCL, SDA		-0.5	0.3 × V <sub>CCI</sub>	V
		ADDR, P17–P00, $\overline{\text{RESET}}$		-0.5	0.3 × V <sub>CCP</sub>	
I <sub>OH</sub>	High-level output current	P17–P00				10 mA
I <sub>OL</sub>	Low-level output current	P17–P00				25 mA
T <sub>A</sub>	Operating free-air temperature			-40	85	°C
θ <sub>JA</sub>	Package thermal impedance <sup>(1)</sup>		PW package			88 °C/W
			RTW package			66 °C/W
			ZQS package			171.6 °C/W

- (1) The package thermal impedance is calculated in accordance with JESD 51-7.

TCA6416

SCPS153B –DECEMBER 2007–REVISED JUNE 2014

www.ti.com

### 6.4 Electrical Characteristics

over recommended operating free-air temperature range,  $V_{CC1} = 1.65\text{ V to }5.5\text{ V}$  (unless otherwise noted)

PARAMETER		TEST CONDITIONS	$V_{CCP}$	MIN	TYP <sup>(1)</sup>	MAX	UNIT
$V_{IK}$	Input diode clamp voltage	$I_I = -18\text{ mA}$	1.65 V to 5.5 V	-1.2			V
$V_{POR}$	Power-on reset voltage	$V_I = V_{CCP}$ or GND, $I_O = 0$	1.65 V to 5.5 V		1	1.4	V
$V_{OH}$	P-port high-level output voltage	$I_{OH} = -8\text{ mA}$	1.65 V	1.2			V
			2.3 V	1.8			
			3 V	2.6			
			4.5 V	4.1			
		$I_{OH} = -10\text{ mA}$	1.65 V	1			
			2.3 V	1.7			
			3 V	2.5			
			4.5 V	4.0			
$V_{OL}$	P-port low-level output voltage	$I_{OL} = 8\text{ mA}$	1.65 V			0.45	V
			2.3 V			0.25	
			3 V			0.25	
			4.5 V			0.23	
		$I_{OL} = 10\text{ mA}$	1.65 V			0.6	
			2.3 V			0.3	
			3 V			0.25	
			4.5 V			0.24	
$I_{OL}$	SDA	$V_{OL} = 0.4\text{ V}$	1.65 V to 5.5 V	3			mA
	$\overline{INT}$	$V_{OL} = 0.4\text{ V}$	1.65 V to 5.5 V	3	15		
$I_I$	SCL, SDA	$V_I = V_{CC1}$ or GND	1.65 V to 5.5 V			$\pm 0.1$	$\mu\text{A}$
	ADDR, $\overline{RESET}$	$V_I = V_{CCP}$ or GND				$\pm 0.1$	
$I_{IH}$	P port	$V_I = V_{CCP}$	1.65 V to 5.5 V			1	$\mu\text{A}$
$I_{IL}$	P port	$V_I = \text{GND}$				1	
$I_{CC}$ ( $I_{CC1} + I_{CCP}$ )	SDA, P port, ADDR, $\overline{RESET}$	$V_I$ on SDA = $V_{CC1}$ or GND, $V_I$ on P port, ADDR and $\overline{RESET} = V_{CCP}$ , $I_O = 0$ , I/O = inputs, $f_{SCL} = 400\text{ kHz}$	1.65 V to 5.5 V		7.8	30	$\mu\text{A}$
	SDA, P port, ADDR, $\overline{RESET}$	$V_I$ on SDA = $V_{CC1}$ or GND, $V_I$ on P port, ADDR and $\overline{RESET} = V_{CCP}$ , $I_O = 0$ , I/O = inputs, $f_{SCL} = 100\text{ kHz}$	1.65 V to 5.5 V		1.7	10	
	SCL, SDA, P port, ADDR, $\overline{RESET}$	$V_I$ on SCL and SDA = $V_{CC1}$ or GND, $V_I$ on P port, ADDR and $\overline{RESET} = V_{CCP}$ , $I_O = 0$ , I/O = inputs, $f_{SCL} = 0$	1.65 V to 5.5 V		0.1	2	
$\Delta I_{CC1}$ $\Delta I_{CCP}$	SCL, SDA	One input at $V_{CC1} - 0.6\text{ V}$ , Other inputs at $V_{CC1}$ or GND	1.65 V to 5.5 V			25	$\mu\text{A}$
	P port, ADDR, $\overline{RESET}$	One input at $V_{CCP} - 0.6\text{ V}$ , Other inputs at $V_{CCP}$ or GND				60	
$C_I$	SCL	$V_I = V_{CC1}$ or GND	1.65 V to 5.5 V		6	7	pF
$C_{IO}$	SDA	$V_{IO} = V_{CC1}$ or GND	1.65 V to 5.5 V		7	8	pF
	P port	$V_{IO} = V_{CCP}$ or GND			7.5	8.5	

(1) Except for  $I_{CC}$ , all typical values are at nominal supply voltage (1.8-V, 2.5-V, 3.3-V, or 5-V  $V_{CC}$ ) and  $T_A = 25^\circ\text{C}$ . For  $I_{CC}$ , the typical values are at  $V_{CCP} = V_{CC1} = 3.3\text{ V}$  and  $T_A = 25^\circ\text{C}$ .

## 6.5 I<sup>2</sup>C Interface Timing Requirements

over recommended operating free-air temperature range (unless otherwise noted) (see [Figure 14](#))

		STANDARD MODE I <sup>2</sup> C BUS		FAST MODE I <sup>2</sup> C BUS		UNIT
		MIN	MAX	MIN	MAX	
t <sub>scl</sub>	I <sup>2</sup> C clock frequency	0	100	0	400	kHz
t <sub>sch</sub>	I <sup>2</sup> C clock high time	4		0.6		μs
t <sub>scl</sub>	I <sup>2</sup> C clock low time	4.7		1.3		μs
t <sub>sp</sub>	I <sup>2</sup> C spike time	0	50	0	50	ns
t <sub>sds</sub>	I <sup>2</sup> C serial data setup time	250		100		ns
t <sub>sdh</sub>	I <sup>2</sup> C serial data hold time	0		0		ns
t <sub>icr</sub>	I <sup>2</sup> C input rise time		1000	20 + 0.1C <sub>b</sub> <sup>(1)</sup>	300	ns
t <sub>icf</sub>	I <sup>2</sup> C input fall time		300	20 + 0.1C <sub>b</sub> <sup>(1)</sup>	300	ns
t <sub>ocf</sub>	I <sup>2</sup> C output fall time; 10 pF to 400 pF bus		300	20 + 0.1C <sub>b</sub> <sup>(1)</sup>	300	μs
t <sub>buf</sub>	I <sup>2</sup> C bus free time between Stop and Start	4.7		1.3		μs
t <sub>sts</sub>	I <sup>2</sup> C Start or repeater Start condition setup time	4.7		0.6		μs
t <sub>sth</sub>	I <sup>2</sup> C Start or repeater Start condition hold time	4		0.6		μs
t <sub>sps</sub>	I <sup>2</sup> C Stop condition setup time	4		0.6		μs
t <sub>vd(data)</sub>	Valid data time; SCL low to SDA output valid		1		1	μs
t <sub>vd(ack)</sub>	Valid data time of ACK condition; ACK signal from SCL low to SDA (out) low		1		1	μs

(1) C<sub>b</sub> = total capacitance of one bus line in pF

## 6.6 Reset Timing Requirements

over recommended operating free-air temperature range (unless otherwise noted) (see [Figure 17](#))

		STANDARD MODE I <sup>2</sup> C BUS		FAST MODE I <sup>2</sup> C BUS		UNIT
		MIN	MAX	MIN	MAX	
t <sub>W</sub>	Reset pulse duration	4		4		ns
t <sub>REC</sub>	Reset recovery time	0		0		ns
t <sub>RESET</sub>	Time to reset <sup>(1)</sup>	600		600		ns

(1) Minimum time for SDA to become high or minimum time to wait before doing a START

## 6.7 Switching Characteristics

over recommended operating free-air temperature range, C<sub>L</sub> ≤ 100 pF (unless otherwise noted) (see [Figure 14](#))

PARAMETER	FROM	TO	STANDARD MODE I <sup>2</sup> C BUS		FAST MODE I <sup>2</sup> C BUS		UNIT
			MIN	MAX	MIN	MAX	
t <sub>IV</sub>	Interrupt valid time	P port		4		4	μs
t <sub>IR</sub>	Interrupt reset delay time	SCL		4		4	μs
t <sub>PV</sub>	Output data valid	SCL		400		400	ns
t <sub>PS</sub>	Input data setup time	P port	0		0		ns
t <sub>PH</sub>	Input data hold time	P port	300		300		ns

TCA6416

SCPS153B – DECEMBER 2007 – REVISED JUNE 2014

www.ti.com

### 6.8 Typical Characteristics

T<sub>A</sub> = 25°C (unless otherwise noted)

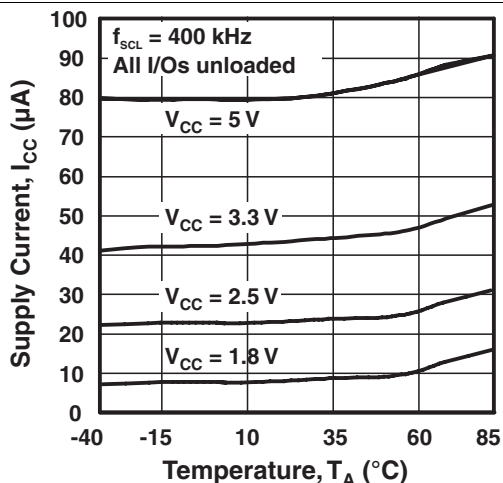

Figure 1. Supply Current vs Temperature

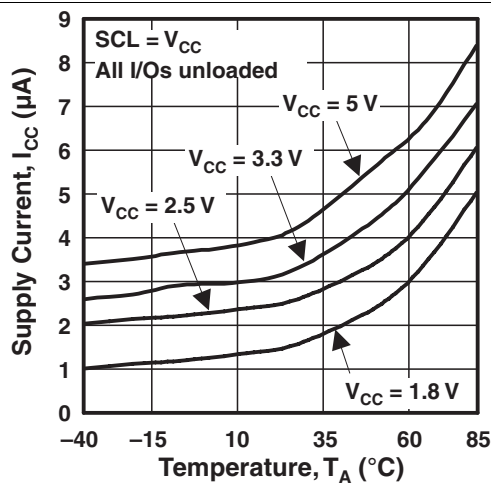

Figure 2. Standby Supply Current vs Temperature

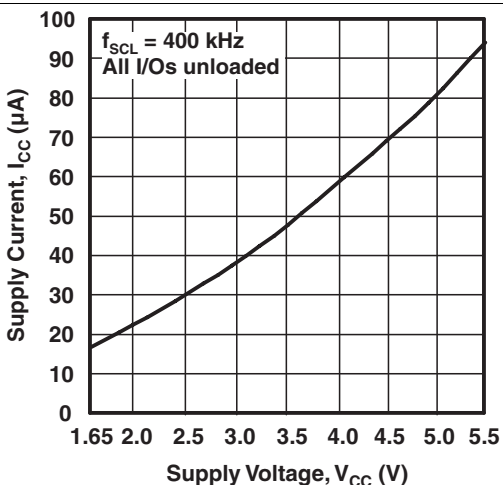

Figure 3. Supply Current vs Supply Voltage

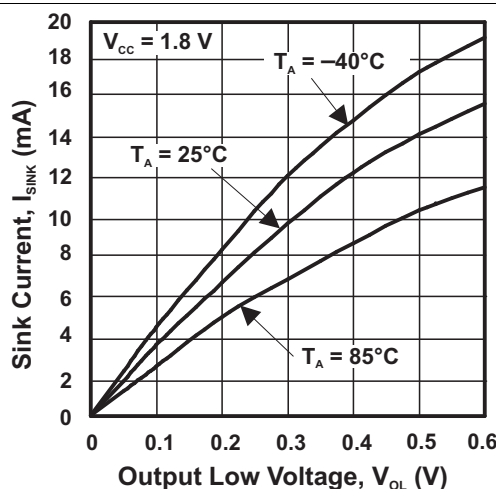

Figure 4. I/O Sink Current vs Output Low Voltage

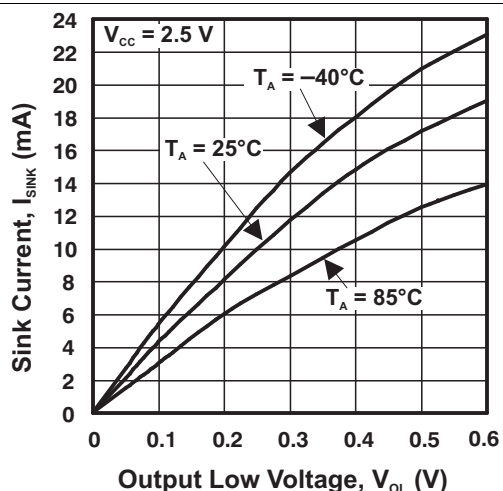

Figure 5. I/O Sink Current vs Output Low Voltage

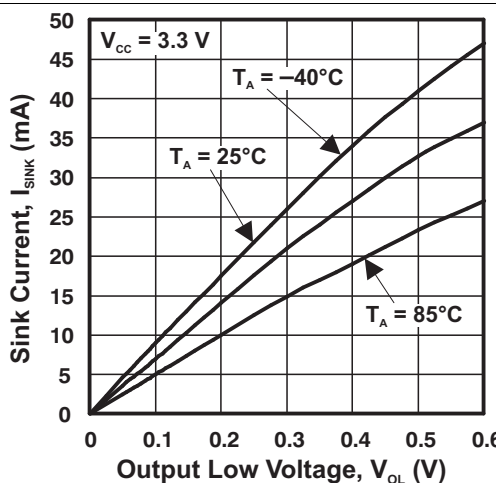

Figure 6. I/O Sink Current vs Output Low Voltage

Typical Characteristics (continued)

T<sub>A</sub> = 25°C (unless otherwise noted)

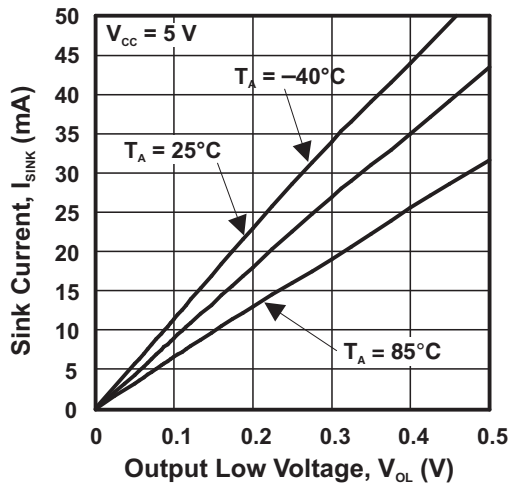

Figure 7. I/O Sink Current vs Output Low Voltage

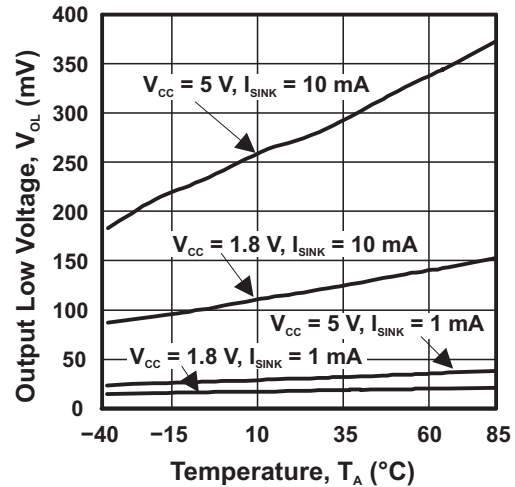

Figure 8. I/O Low Voltage vs Temperature

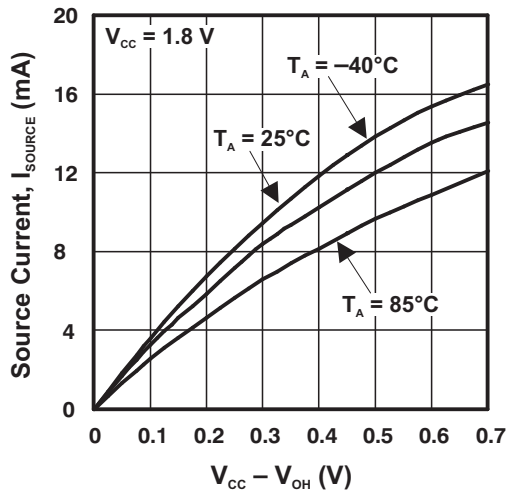

Figure 9. I/O Source Current vs Output High Voltage

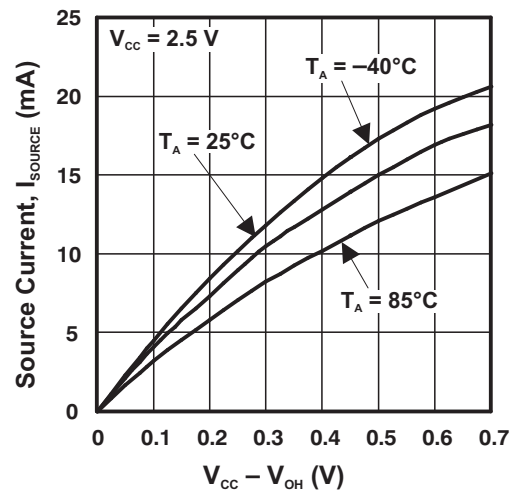

Figure 10. I/O Source Current vs Output High Voltage

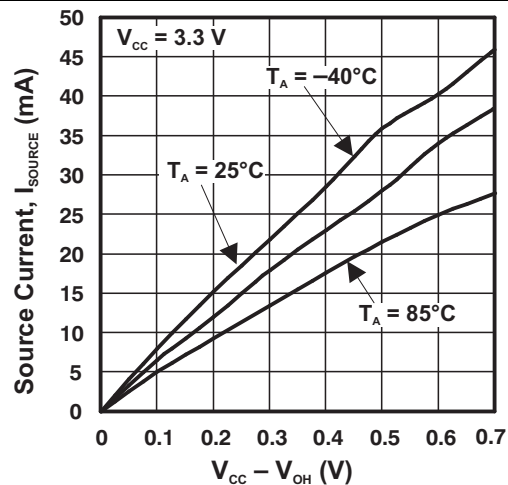

Figure 11. I/O Source Current vs Output High Voltage

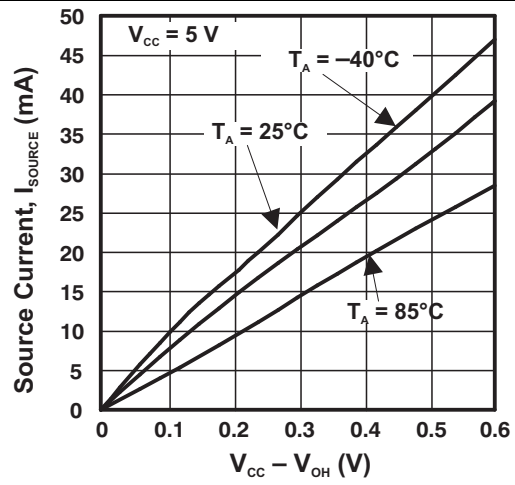

Figure 12. I/O Source Current vs Output High Voltage

TCA6416

SCPS153B –DECEMBER 2007–REVISED JUNE 2014

www.ti.com

Typical Characteristics (continued)

$T_A = 25^\circ\text{C}$  (unless otherwise noted)

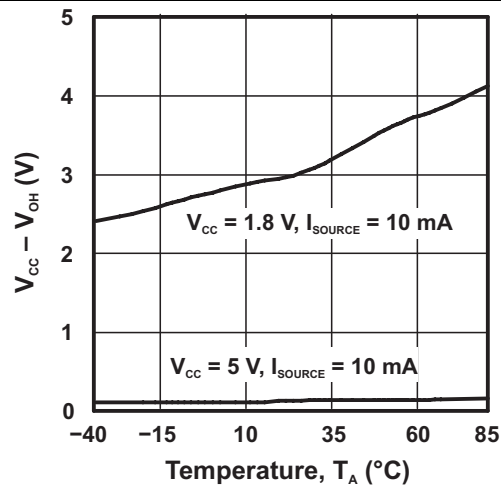
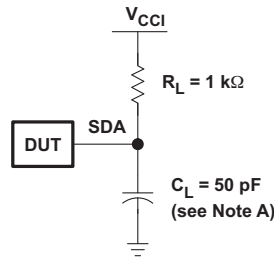
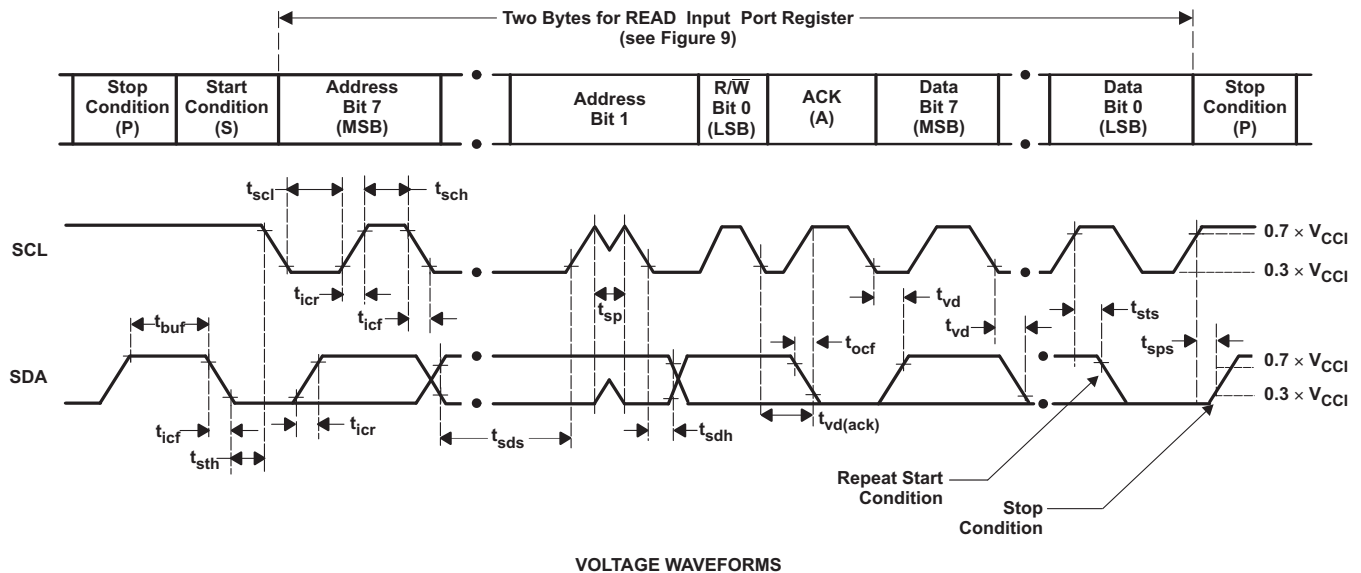

Figure 13. I/O High Voltage vs Temperature

## 7 Parameter Measurement Information



SDA LOAD CONFIGURATION



VOLTAGE WAVEFORMS

BYTE	DESCRIPTION
1	I <sup>2</sup> C address
2	Input register port data

- A.  $C_L$  includes probe and jig capacitance.  $t_{ocf}$  is measured with  $C_L$  of 10 pF or 400 pF.
- B. All inputs are supplied by generators having the following characteristics:  $PRR \leq 10$  MHz,  $Z_O = 50 \Omega$ ,  $t_r/t_f \leq 30$  ns.
- C. All parameters and waveforms are not applicable to all devices.

Figure 14. I<sup>2</sup>C Interface Load Circuit And Voltage Waveforms

Parameter Measurement Information (continued)

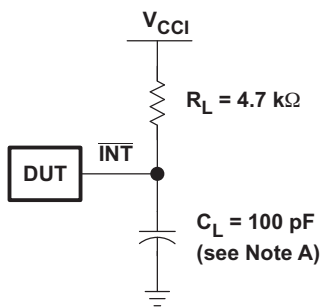

INTERRUPT LOAD CONFIGURATION

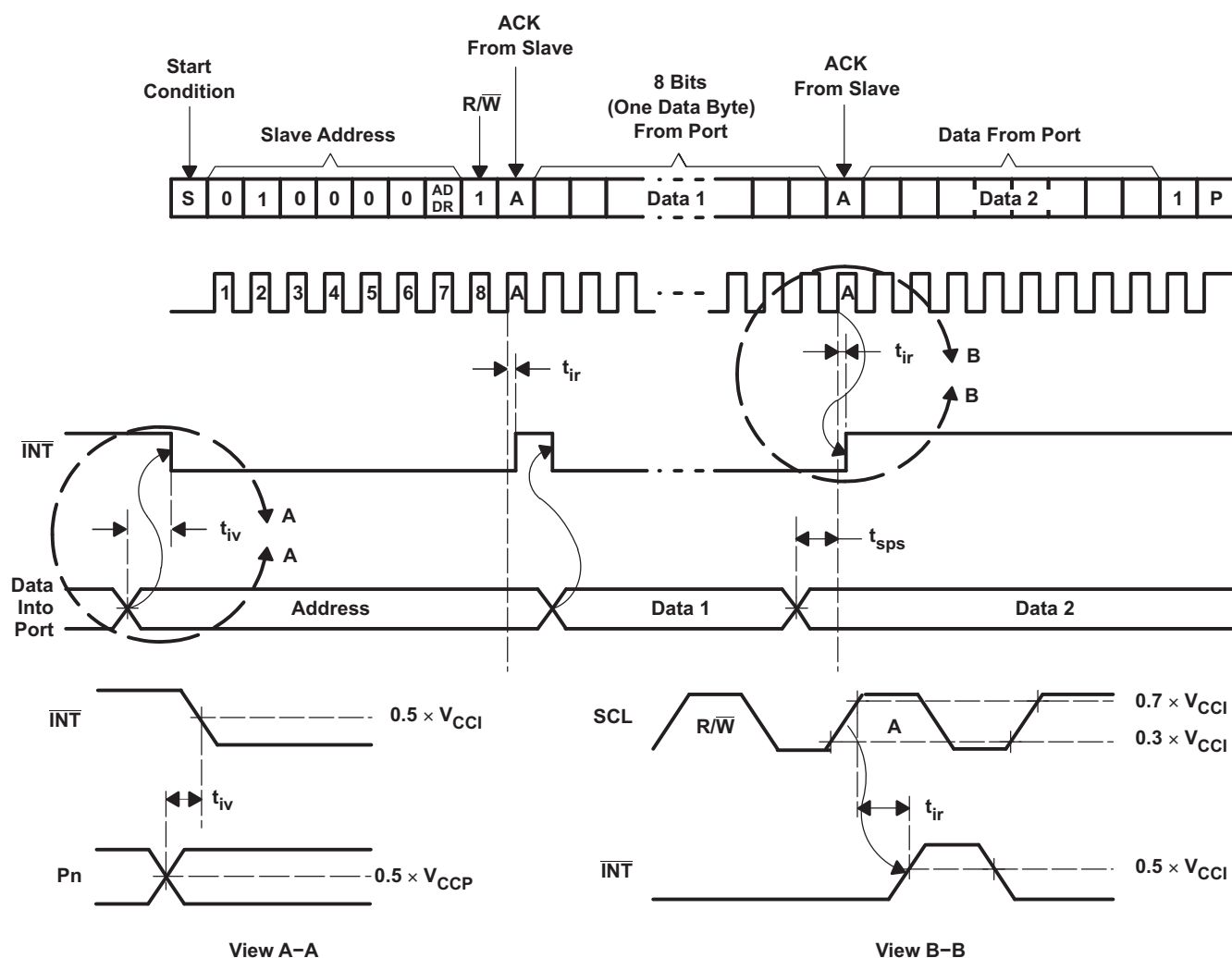

- A.  $C_L$  includes probe and jig capacitance.
- B. All inputs are supplied by generators having the following characteristics:  $PRR \leq 10$  MHz,  $Z_O = 50 \Omega$ ,  $t_r/t_f \leq 30$  ns.
- C. All parameters and waveforms are not applicable to all devices.

Figure 15. Interrupt Load Circuit And Voltage Waveforms

Parameter Measurement Information (continued)

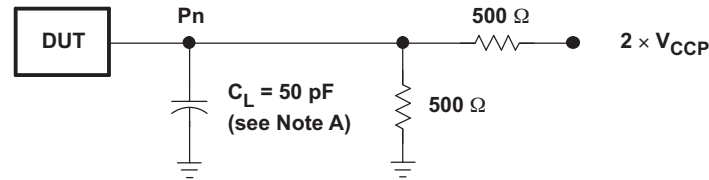

P-PORT LOAD CONFIGURATION

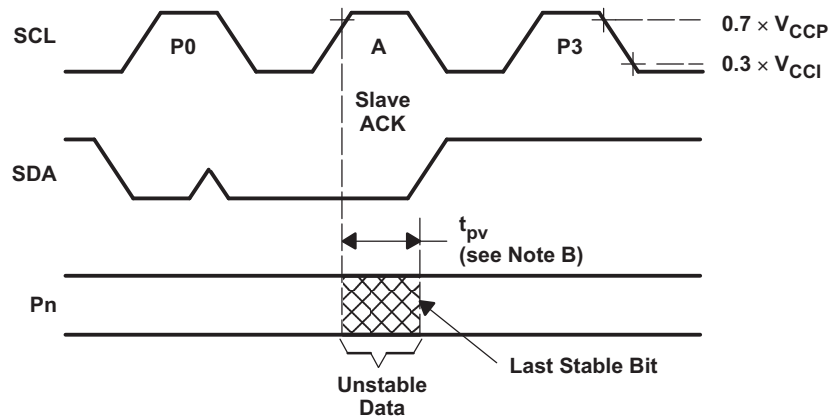

WRITE MODE ( $R/\bar{W} = 0$ )

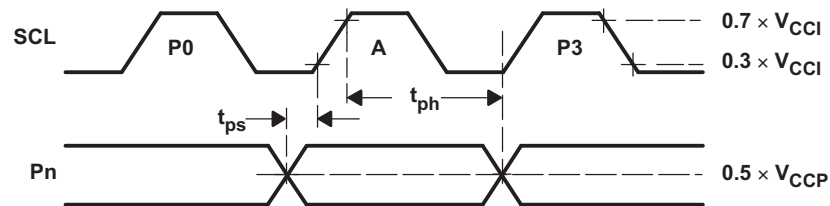

READ MODE ( $R/\bar{W} = 1$ )

- A.  $C_L$  includes probe and jig capacitance.
- B.  $t_{pv}$  is measured from  $0.7 \times V_{CC}$  on SCL to 50% I/O ( $P_n$ ) output.
- C. All inputs are supplied by generators having the following characteristics:  $PRR \leq 10$  MHz,  $Z_O = 50 \Omega$ ,  $t_r/t_f \leq 30$  ns.
- D. The outputs are measured one at a time, with one transition per measurement.
- E. All parameters and waveforms are not applicable to all devices.

Figure 16. P Port Load Circuit And Timing Waveforms

Parameter Measurement Information (continued)

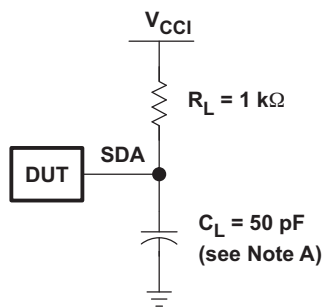

SDA LOAD CONFIGURATION

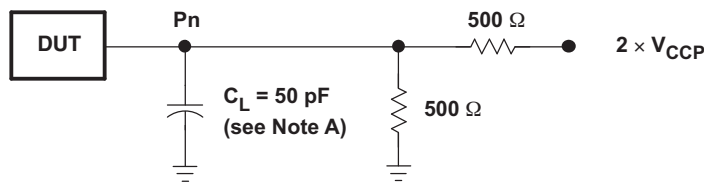

P-PORT LOAD CONFIGURATION

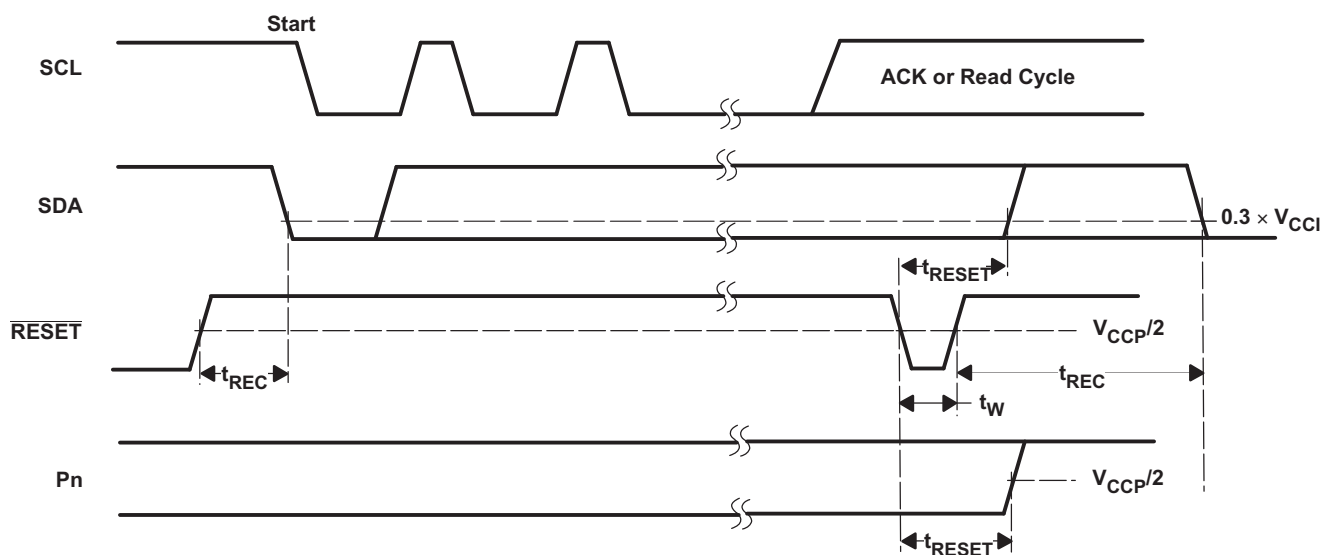

- A.  $C_L$  includes probe and jig capacitance.
- B. All inputs are supplied by generators having the following characteristics:  $PRR \leq 10\text{ MHz}$ ,  $Z_O = 50\ \Omega$ ,  $t_r/t_f \leq 30\text{ ns}$ .
- C. The outputs are measured one at a time, with one transition per measurement.
- D. I/Os are configured as inputs.
- E. All parameters and waveforms are not applicable to all devices.

Figure 17. Reset Load Circuits And Voltage Waveforms

## 8 Detailed Description

### 8.1 Functional Block Diagram

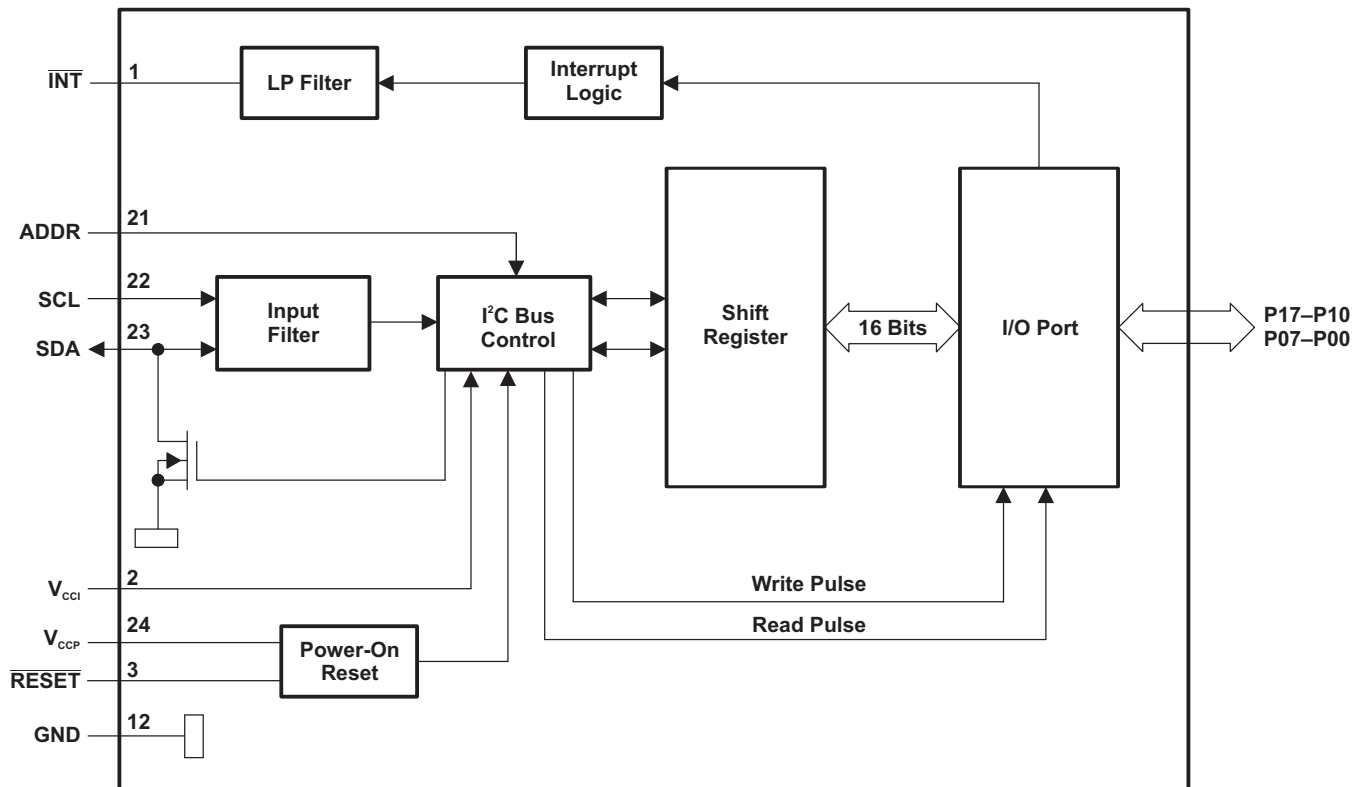

- A. All I/Os are set to inputs at reset.
- B. Pin numbers shown are for the PW package.

Figure 18. Logic Diagram (Positive Logic)

Functional Block Diagram (continued)

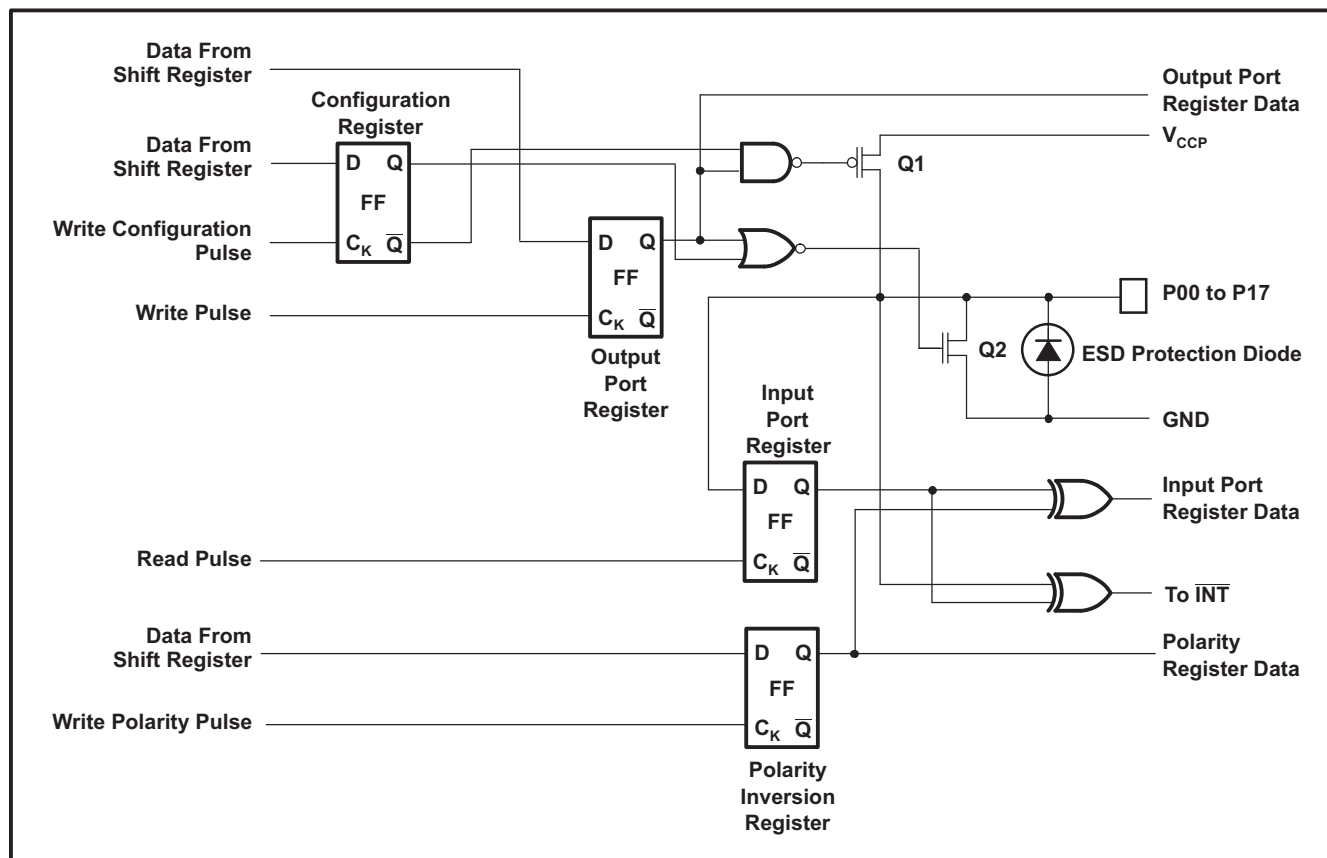

A. On power up or reset, all registers return to default values.

Figure 19. Simplified Schematic Of P0 To P17

## 8.2 Device Functional Modes

### 8.2.1 Voltage Translation

Table 1 shows how to set up  $V_{CC}$  levels for the necessary voltage translation between the I<sup>2</sup>C bus and the TCA6416.

**Table 1. Voltage Translation**

$V_{CCI}$ (SDA AND SCL OF I <sup>2</sup> C MASTER) (V)	$V_{CCP}$ (P PORT) (V)
1.8	1.8
1.8	2.5
1.8	3.3
1.8	5
2.5	1.8
2.5	2.5
2.5	3.3
2.5	5
3.3	1.8
3.3	2.5
3.3	3.3
3.3	5
5	1.8
5	2.5
5	3.3
5	5

### 8.2.2 Reset Input ( $\overline{\text{RESET}}$ )

The  $\overline{\text{RESET}}$  input can be asserted to initialize the system while keeping the  $V_{CCP}$  at its operating level. A reset can be accomplished by holding the  $\overline{\text{RESET}}$  pin low for a minimum of  $t_W$ . The TCA6416 registers and I<sup>2</sup>C/SMBus state machine are changed to their default state once  $\overline{\text{RESET}}$  is low (0). When  $\overline{\text{RESET}}$  is high (1), the I/O levels at the P port can be changed externally or through the master. This input requires a pullup resistor to  $V_{CCP}$ , if no active connection is used.

#### 8.2.2.1 $\overline{\text{RESET}}$ Errata

If  $\overline{\text{RESET}}$  voltage set higher than VCC, current will flow from  $\overline{\text{RESET}}$  pin to VCC pin.

#### System Impact

VCC will be pulled above its regular voltage level

#### System Workaround

Design such that  $\overline{\text{RESET}}$  voltage is same or lower than VCC

### 8.2.3 Power-On Reset

When power (from 0 V) is applied to  $V_{CCP}$ , an internal power-on reset holds the TCA6416 in a reset condition until  $V_{CCP}$  has reached  $V_{POR}$ . At that time, the reset condition is released, and the TCA6416 registers and I<sup>2</sup>C/SMBus state machine initializes to their default states. After that,  $V_{CCP}$  must be lowered to below 0.2 V and back up to the operating voltage for a power-reset cycle.

**TCA6416**

SCPS153B – DECEMBER 2007 – REVISED JUNE 2014

www.ti.com

**8.2.4 I/O Port**

When an I/O is configured as an input, FETs Q1 and Q2 (in Figure 19) are off, which creates a high-impedance input. The input voltage may be raised above  $V_{CC}$  to a maximum of 5.5 V.

If the I/O is configured as an output, Q1 or Q2 is enabled, depending on the state of the output port register. In this case, there are low-impedance paths between the I/O pin and either  $V_{CC}$  or GND. The external voltage applied to this I/O pin should not exceed the recommended levels for proper operation.

**8.2.5 Interrupt ( $\overline{\text{INT}}$ ) Output**

An interrupt is generated by any rising or falling edge of the port inputs in the input mode. After time  $t_{iv}$ , the signal  $\overline{\text{INT}}$  is valid. Resetting the interrupt circuit is achieved when data on the port is changed to the original setting, data is read from the port that generated the interrupt or in a stop event. Resetting occurs in the read mode at the acknowledge (ACK) or not acknowledge (NACK) bit after the rising edge of the SCL signal. Interrupts that occur during the ACK or NACK clock pulse can be lost (or be very short) due to the resetting of the interrupt during this pulse. Each change of the I/Os after resetting is detected and is transmitted as  $\overline{\text{INT}}$ .

Reading from or writing to another device does not affect the interrupt circuit, and a pin configured as an output cannot cause an interrupt. Changing an I/O from an output to an input may cause a false interrupt to occur, if the state of the pin does not match the contents of the Input Port register.

In the TCA6416, an interrupt is not immediately generated by any rising or falling edge of port inputs in input mode after issuing any I<sup>2</sup>C commands (read or write). In order to capture the  $\overline{\text{INT}}$  in the TCA6416, the user needs to add one more SCL clock pulse after a Stop signal.

The  $\overline{\text{INT}}$  output has an open-drain structure and requires a pullup resistor to  $V_{CCP}$  or  $V_{CCI}$  depending on the application. If the  $\overline{\text{INT}}$  signal is connected back to the processor that provides the SCL signal to the TCA6416, then the  $\overline{\text{INT}}$  pin has to be connected to  $V_{CCI}$ . If not, the INT pin can be connected to  $V_{CCP}$ .

**8.2.5.1 Interrupt Errata**

The INT will be improperly de-asserted if the following two conditions occur:

1. The last I<sup>2</sup>C command byte (register pointer) written to the device was 00h.

**NOTE**

This generally means the last operation with the device was a Read of the input register. However, the command byte may have been written with 00h without ever going on to read the input register. After reading from the device, if no other command byte written, it will remain 00h.

2. Any other slave device on the I<sup>2</sup>C bus acknowledges an address byte with the R/W bit set high

**System Impact**

Can cause improper interrupt handling as the Master will see the interrupt as being cleared.

**System Workaround**

Minor software change: User must change command byte to something besides 00h after a Read operation to the TCA6416 device or before reading from another slave device.

**NOTE**

Software change will be compatible with other versions (competition and TI redesigns) of this device.

## 8.3 Programming

### 8.3.1 I<sup>2</sup>C Interface

The bidirectional I<sup>2</sup>C bus consists of the serial clock (SCL) and serial data (SDA) lines. Both lines must be connected to a positive supply through a pullup resistor when connected to the output stages of a device. Data transfer may be initiated only when the bus is not busy.

I<sup>2</sup>C communication with this device is initiated by a master sending a Start condition, a high-to-low transition on the SDA input/output, while the SCL input is high (see Figure 20). After the Start condition, the device address byte is sent, most significant bit (MSB) first, including the data direction bit (R/W).

After receiving the valid address byte, this device responds with an acknowledge (ACK), a low on the SDA input/output during the high of the ACK-related clock pulse. The address (ADDR) input of the slave device must not be changed between the Start and the Stop conditions.

On the I<sup>2</sup>C bus, only one data bit is transferred during each clock pulse. The data on the SDA line must remain stable during the high pulse of the clock period, as changes in the data line at this time are interpreted as control commands (Start or Stop) (see Figure 21).

A Stop condition, a low-to-high transition on the SDA input/output while the SCL input is high, is sent by the master (see Figure 20).

Any number of data bytes can be transferred from the transmitter to receiver between the Start and the Stop conditions. Each byte of eight bits is followed by one ACK bit. The transmitter must release the SDA line before the receiver can send an ACK bit. The device that acknowledges must pull down the SDA line during the ACK clock pulse, so that the SDA line is stable low during the high pulse of the ACK-related clock period (see Figure 22). When a slave receiver is addressed, it must generate an ACK after each byte is received. Similarly, the master must generate an ACK after each byte that it receives from the slave transmitter. Setup and hold times must be met to ensure proper operation.

A master receiver signals an end of data to the slave transmitter by not generating an acknowledge (NACK) after the last byte has been clocked out of the slave. This is done by the master receiver by holding the SDA line high. In this event, the transmitter must release the data line to enable the master to generate a Stop condition.

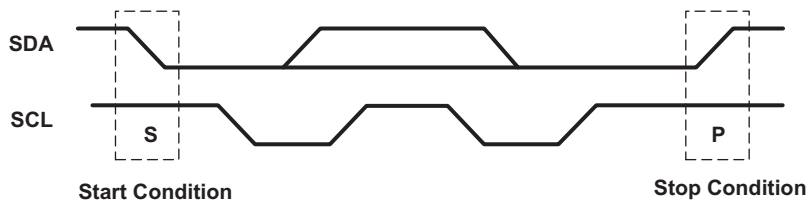

Figure 20. Definition Of Start And Stop Conditions

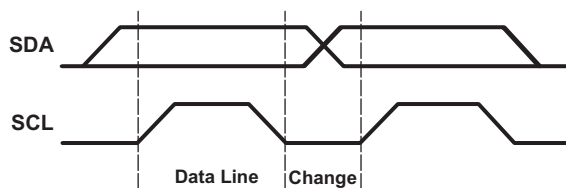

Figure 21. Bit Transfer

TCA6416

SCPS153B –DECEMBER 2007–REVISED JUNE 2014

www.ti.com

Programming (continued)

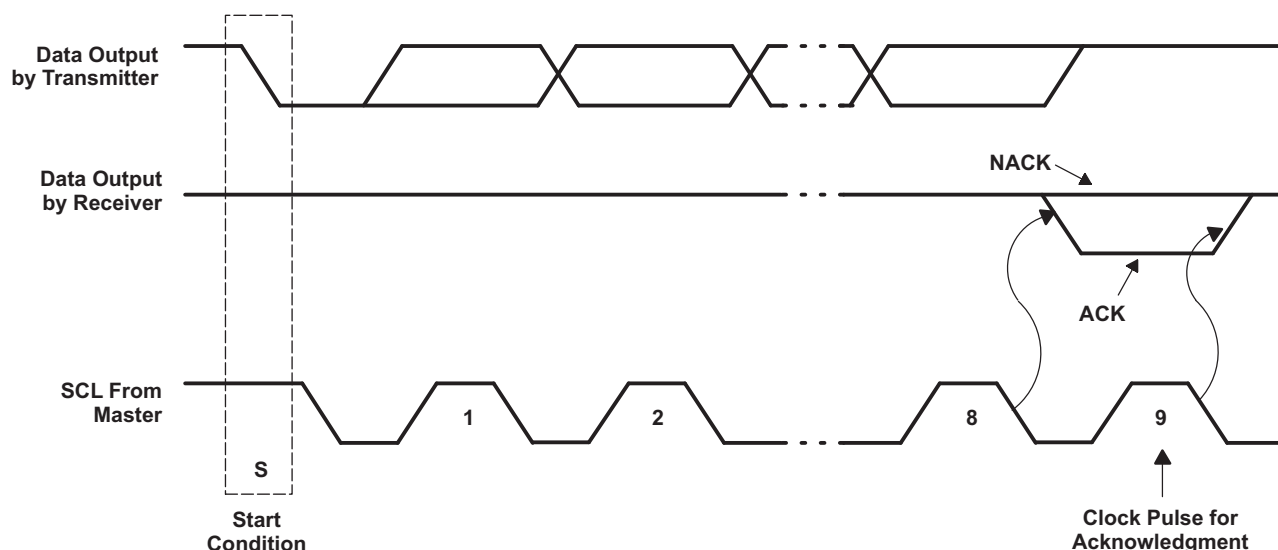

Figure 22. Acknowledgment On The I<sup>2</sup>C Bus

8.3.2 Register Map

Table 2. Interface Definition

BYTE	BIT							
	7 (MSB)	6	5	4	3	2	1	0 (LSB)
I <sup>2</sup> C slave address	L	H	L	L	L	L	ADDR	R/W
I/O data bus	P07	P06	P05	P04	P03	P02	P01	P00
	P17	P16	P15	P14	P13	P12	P11	P10

8.3.2.1 Device Address

The address of the TCA6416 is shown in Figure 23.

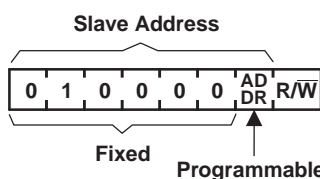

Figure 23. Tca6416 Address

Table 3. Address Reference

ADDR	I <sup>2</sup> C BUS SLAVE ADDRESS
L	32 (decimal), 20 (hexadecimal)
H	33 (decimal), 21 (hexadecimal)

The last bit of the slave address defines the operation (read or write) to be performed. A high (1) selects a read operation, while a low (0) selects a write operation.

### 8.3.2.2 Control Register And Command Byte

Following the successful acknowledgment of the address byte, the bus master sends a command byte, which is stored in the control register in the TCA6416. Three bits of this data byte state the operation (read or write) and the internal registers (input, output, polarity inversion, or configuration) that will be affected. This register can be written or read through the I<sup>2</sup>C bus. The command byte is sent only during a write transmission.

Once a new command has been sent, the register that was addressed continues to be accessed by reads until a new command byte has been sent.

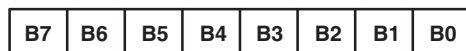

**Figure 24. Control Register Bits**

**Table 4. Command Byte**

CONTROL REGISTER BITS								COMMAND BYTE (HEX)	REGISTER	PROTOCOL	POWER-UP DEFAULT
B7	B6	B5	B4	B3	B2	B1	B0				
0	0	0	0	0	0	0	0	00	Input Port 0	Read byte	xxxx xxxx <sup>(1)</sup>
0	0	0	0	0	0	0	1	01	Input Port 1	Read byte	xxxx xxxx
0	0	0	0	0	0	1	0	02	Output Port 0	Read/write byte	1111 1111
0	0	0	0	0	0	1	1	03	Output Port 1	Read/write byte	1111 1111
0	0	0	0	0	1	0	0	04	Polarity Inversion Port 0	Read/write byte	0000 0000
0	0	0	0	0	1	0	1	05	Polarity Inversion Port 1	Read/write byte	0000 0000
0	0	0	0	0	1	1	0	06	Configuration Port 0	Read/write byte	1111 1111
0	0	0	0	0	1	1	1	07	Configuration Port 1	Read/write byte	1111 1111

(1) Undefined

### 8.3.2.3 Register Descriptions

The Input Port registers (registers 0 and 1) reflect the incoming logic levels of the pins, regardless of whether the pin is defined as an input or an output by the Configuration register. They act only on read operation. Writes to these registers have no effect. The default value (X) is determined by the externally applied logic level. Before a read operation, a write transmission is sent with the command byte to indicate to the I<sup>2</sup>C device that the Input Port register will be accessed next.

**Table 5. Registers 0 And 1 (Input Port Registers)**

<b>BIT</b>	I-07	I-06	I-05	I-04	I-03	I-02	I-01	I-00
<b>DEFAULT</b>	X	X	X	X	X	X	X	X
<b>BIT</b>	I-17	I-16	I-15	I-14	I-13	I-12	I-11	I-10
<b>DEFAULT</b>	X	X	X	X	X	X	X	X

The Output Port registers (registers 2 and 3) shows\ the outgoing logic levels of the pins defined as outputs by the Configuration register. Bit values in these registers have no effect on pins defined as inputs. In turn, reads from these registers reflect the value that is in the flip-flop controlling the output selection, NOT the actual pin value.

**Table 6. Registers 2 And 3 (Output Port Registers)**

<b>BIT</b>	O-07	O-06	O-05	O-04	O-03	O-02	O-01	O-00
<b>DEFAULT</b>	1	1	1	1	1	1	1	1
<b>BIT</b>	O-17	O-16	O-15	O-14	O-13	O-12	O-11	O-10
<b>DEFAULT</b>	1	1	1	1	1	1	1	1

The Polarity Inversion registers (register 4 and 5) allow polarity inversion of pins defined as inputs by the Configuration register. If a bit in these registers is set (written with 1), the corresponding port pin's polarity is inverted. If a bit in these registers is cleared (written with a 0), the corresponding port pin's original polarity is retained.

**Table 7. Registers 4 And 5 (Polarity Inversion Registers)**

<b>BIT</b>	P-07	P-06	P-05	P-04	P-03	P-02	P-01	P-00
<b>DEFAULT</b>	0	0	0	0	0	0	0	0
<b>BIT</b>	P-17	P-16	P-15	P-14	P-13	P-12	P-11	P-10
<b>DEFAULT</b>	0	0	0	0	0	0	0	0

The Configuration registers (registers 6 and 7) configure the direction of the I/O pins. If a bit in these registers is set to 1, the corresponding port pin is enabled as an input with a high-impedance output driver. If a bit in these registers is cleared to 0, the corresponding port pin is enabled as an output.

**Table 8. Registers 6 And 7 (Configuration Registers)**

<b>BIT</b>	C-07	C-06	C-05	C-04	C-03	C-02	C-01	C-00
<b>DEFAULT</b>	1	1	1	1	1	1	1	1
<b>BIT</b>	C-17	C-16	C-15	C-14	C-13	C-12	C-11	C-10
<b>DEFAULT</b>	1	1	1	1	1	1	1	1

### 8.3.2.4 Bus Transactions

Data is exchanged between the master and TCA6416 through write and read commands.

#### 8.3.2.4.1 Writes

Data is transmitted to the TCA6416 by sending the device address and setting the least-significant bit (LSB) to a logic 0 (see Figure 23 for device address). The command byte is sent after the address and determines which register receives the data that follows the command byte. There is no limitation on the number of data bytes sent in one write transmission.

The eight registers within the TCA6416 are configured to operate as four register pairs. The four pairs are input ports, output ports, polarity inversion ports and configuration ports. After sending data to one register, the next data byte is sent to the other register in the pair (see Figure 25 and Figure 26). For example, if the first byte is sent to Output Port 1 (register 3), the next byte is stored in Output Port 0 (register 2).

There is no limitation on the number of data bytes sent in one write transmission. In this way, each 8-bit register can be updated independently of the other registers.

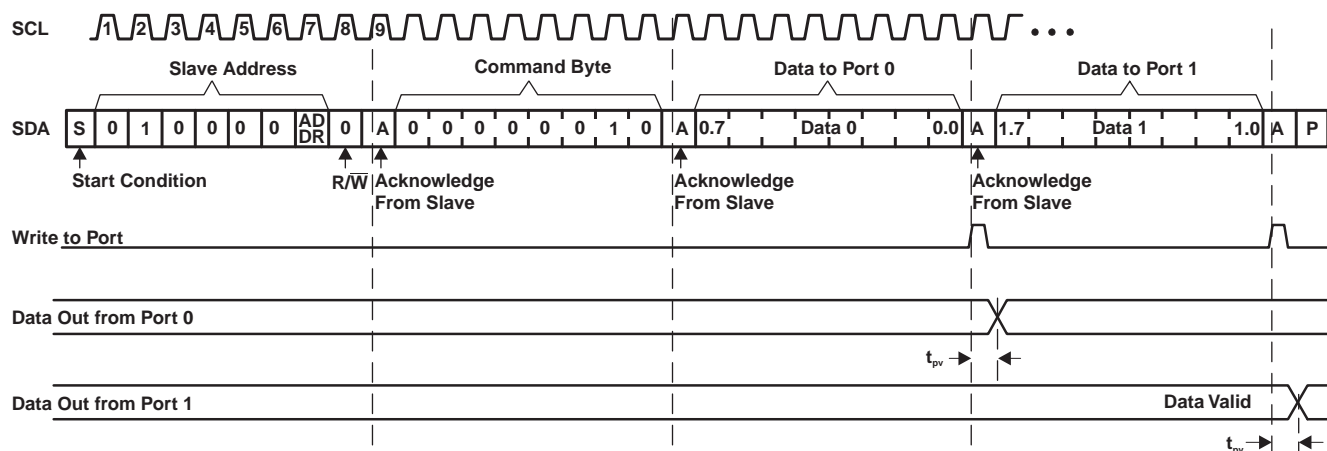

Figure 25. Write To Output Port Register

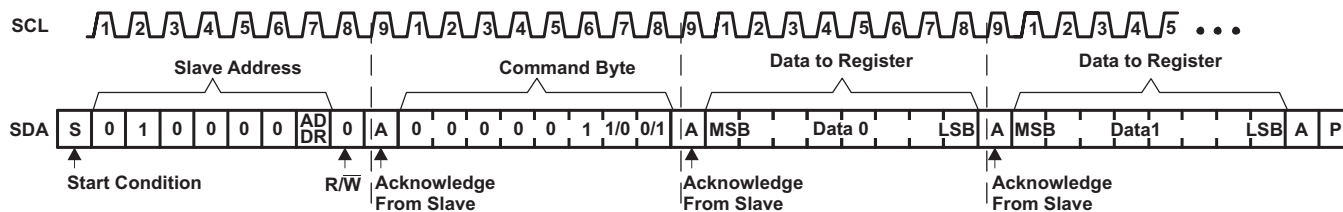

Figure 26. Write To Configuration Or Polarity Inversion Registers

TCA6416

SCPS153B –DECEMBER 2007–REVISED JUNE 2014

www.ti.com

8.3.2.4.2 Reads

The bus master first must send the TCA6416 address with the LSB set to a logic 0 (see Figure 23 for device address). The command byte is sent after the address and determines which register is accessed.

After a restart, the device address is sent again but, this time, the LSB is set to a logic 1. Data from the register defined by the command byte then is sent by the TCA6416 (see Figure 27 and Figure 28).

After a restart, the value of the register defined by the command byte matches the register being accessed when the restart occurred. For example, if the command byte references Input Port 1 before the restart, and the restart occurs when Input Port 0 is being read, the stored command byte changes to reference Input Port 0. The original command byte is forgotten. If a subsequent restart occurs, Input Port 0 is read first. Data is clocked into the register on the rising edge of the ACK clock pulse. After the first byte is read, additional bytes may be read, but the data now reflects the information in the other register in the pair. For example, if Input Port 1 is read, the next byte read is Input Port 0.

Data is clocked into the register on the rising edge of the ACK clock pulse. There is no limitation on the number of data bytes received in one read transmission, but when the final byte is received, the bus master must not acknowledge the data.

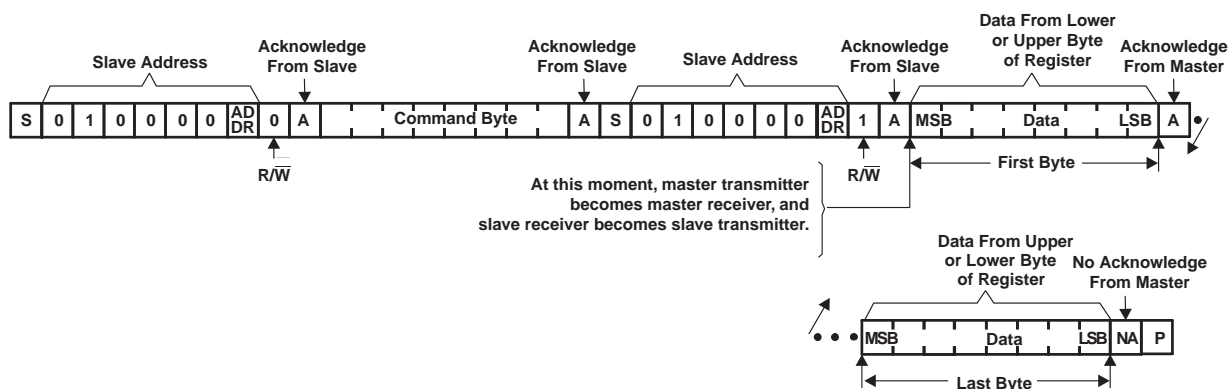
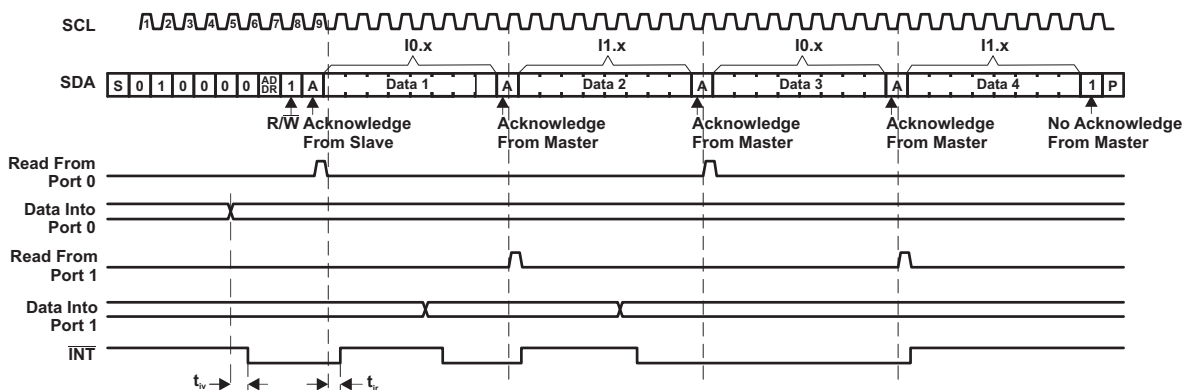

Figure 27. Read From Register



- A. Transfer of data can be stopped at any time by a Stop condition. When this occurs, data present at the latest acknowledge phase is valid (output mode). It is assumed that the command byte previously has been set to 00 (read Input Port register).
- B. This figure eliminates the command byte transfer, a restart, and slave address call between the initial slave address call and actual data transfer from P port (see Figure 27).

Figure 28. Read Input Port Register

## 9 Application And Implementation

### 9.1 Typical Application

Figure 29 shows an application in which the TCA6416 can be used.

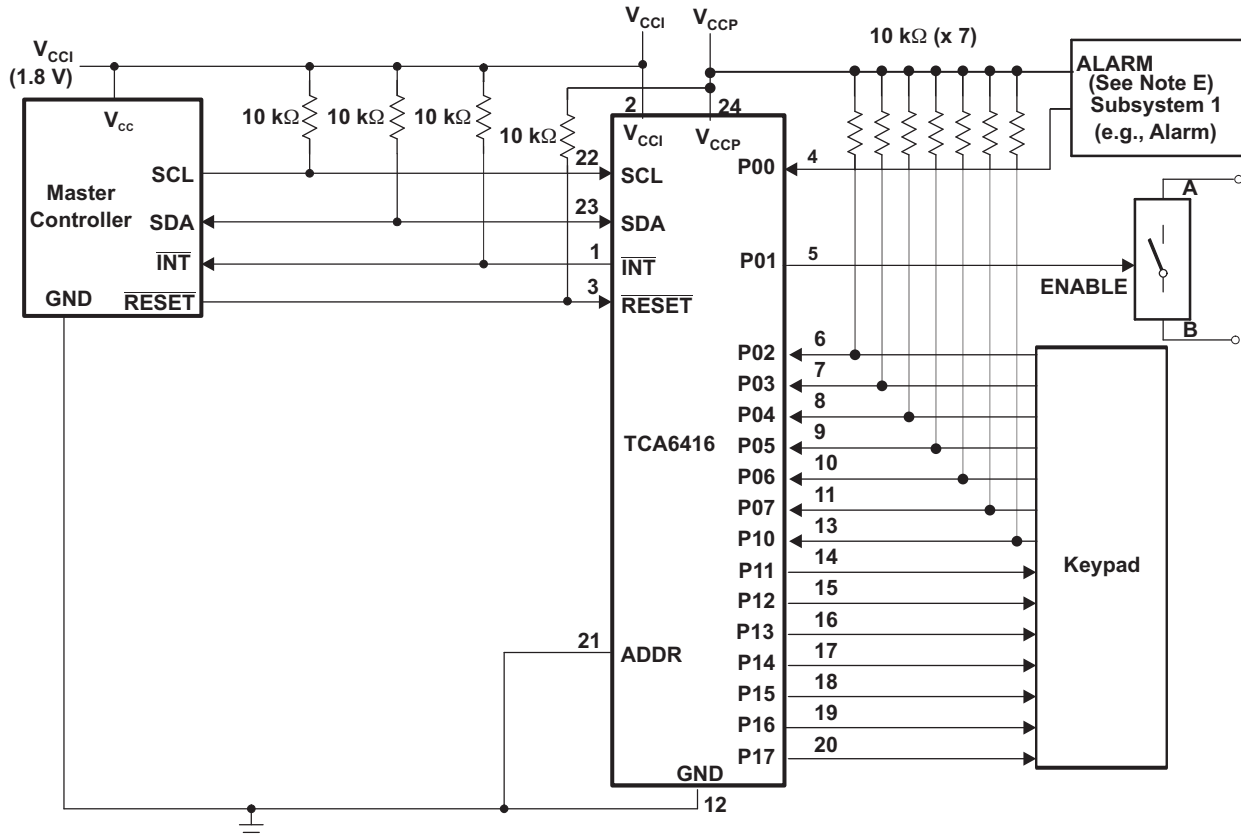

- Device address configured as 0100000 for this example.
- P00 and P02–P10 are configured as inputs.
- P01 and P11–P17 are configured as outputs.
- Pin numbers shown are for the PW package.
- Resistors are required for inputs (on P port) that may float. If a driver to an input will never let the input float, a resistor is not needed. Outputs (in the P port) do not need pullup resistors.

Figure 29. Typical Application

## Typical Application (continued)

### 9.1.1 Detailed Design Procedure

#### 9.1.1.1 Minimizing $I_{CC}$ When I/Os Control Leds

When the I/Os are used to control LEDs, normally they are connected to  $V_{CC}$  through a resistor as shown in Figure 29. The LED acts as a diode so, when the LED is off, the I/O  $V_{IN}$  is about 1.2 V less than  $V_{CC}$ . The  $\Delta I_{CC}$  parameter in Electrical Characteristics shows how  $I_{CC}$  increases as  $V_{IN}$  becomes lower than  $V_{CC}$ . Designs that must minimize current consumption, such as battery power applications, should consider maintaining the I/O pins greater than or equal to  $V_{CC}$  when the LED is off.

Figure 30 shows a high-value resistor in parallel with the LED. Figure 31 shows  $V_{CC}$  less than the LED supply voltage by at least 1.2 V. Both of these methods maintain the I/O  $V_{IN}$  at or above  $V_{CC}$  and prevent additional supply current consumption when the LED is off.

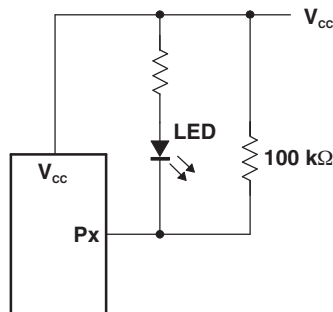

Figure 30. High-Value Resistor In Parallel With The Led

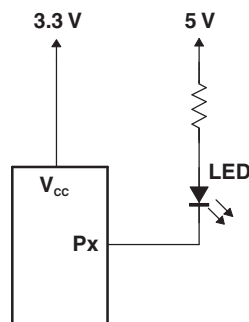

Figure 31. Device Supplied By A Low Voltage

## 10 Power Supply Recommendations

### 10.1 Power-On Reset Requirements

In the event of a glitch or data corruption, TCA6416 can be reset to its default conditions by using the power-on reset feature. Power-on reset requires that the device go through a power cycle to be completely reset. This reset also happens when the device is powered on for the first time in an application.

The two types of power-on reset are shown in [Figure 32](#) and [Figure 33](#).

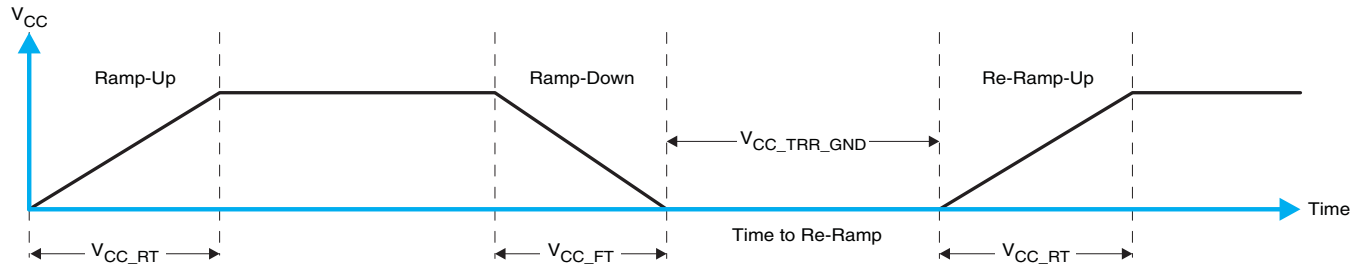

**Figure 32.  $V_{CC}$  Is Lowered Below 0.2 V Or 0 V And Then Ramped Up To  $V_{CC}$**

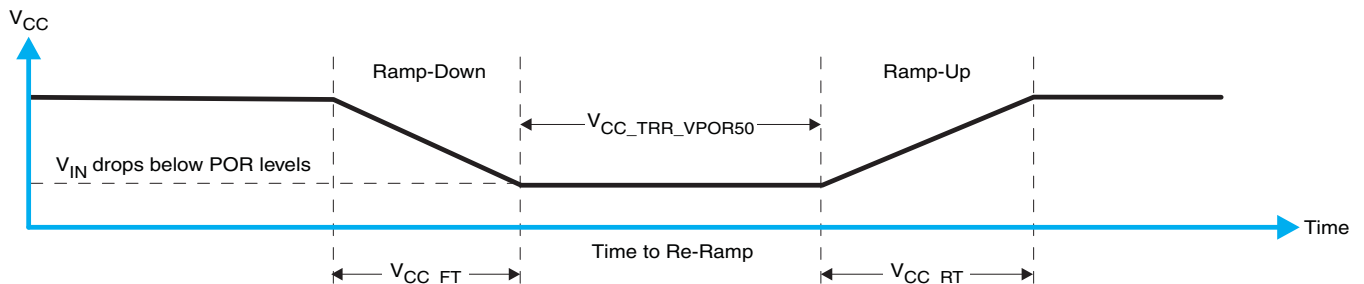

**Figure 33.  $V_{CC}$  Is Lowered Below The Por Threshold, Then Ramped Back Up To  $V_{CC}$**

[Table 9](#) specifies the performance of the power-on reset feature for TCA6416 for both types of power-on reset.

**Table 9. Recommended Supply Sequencing And Ramp Rates<sup>(1)</sup>**

PARAMETER			MIN	TYP	MAX	UNIT
$V_{CC\_FT}$	Fall rate	See <a href="#">Figure 32</a>	1		100	ms
$V_{CC\_RT}$	Rise rate	See <a href="#">Figure 32</a>	0.01		100	ms
$V_{CC\_TRR\_GND}$	Time to re-ramp (when $V_{CC}$ drops to GND)	See <a href="#">Figure 32</a>	0.001			ms
$V_{CC\_TRR\_VPOR50}$	Time to re-ramp (when $V_{CC}$ drops to $V_{POR\_MIN} - 50$ mV)	See <a href="#">Figure 33</a>	0.001			ms
$V_{CC\_GH}$	Level that $V_{CCP}$ can glitch down to, but not cause a functional disruption when $V_{CCX\_GW} = 1$ $\mu$ s	See <a href="#">Figure 34</a>			1.2	V
$V_{CC\_GW}$	Glitch width that will not cause a functional disruption when $V_{CCX\_GH} = 0.5 \times V_{CCx}$	See <a href="#">Figure 34</a>				$\mu$ s
$V_{PORF}$	Voltage trip point of POR on falling $V_{CC}$		0.767		1.144	V
$V_{PORR}$	Voltage trip point of POR on rising $V_{CC}$		1.033		1.428	V

(1)  $T_A = -40^\circ\text{C}$  to  $85^\circ\text{C}$  (unless otherwise noted)

TCA6416

SCPS153B – DECEMBER 2007 – REVISED JUNE 2014

www.ti.com

Glitches in the power supply can also affect the power-on reset performance of this device. The glitch width ( $V_{CC\_GW}$ ) and height ( $V_{CC\_GH}$ ) are dependent on each other. The bypass capacitance, source impedance, and device impedance are factors that affect power-on reset performance. Figure 34 and Table 9 provide more information on how to measure these specifications.

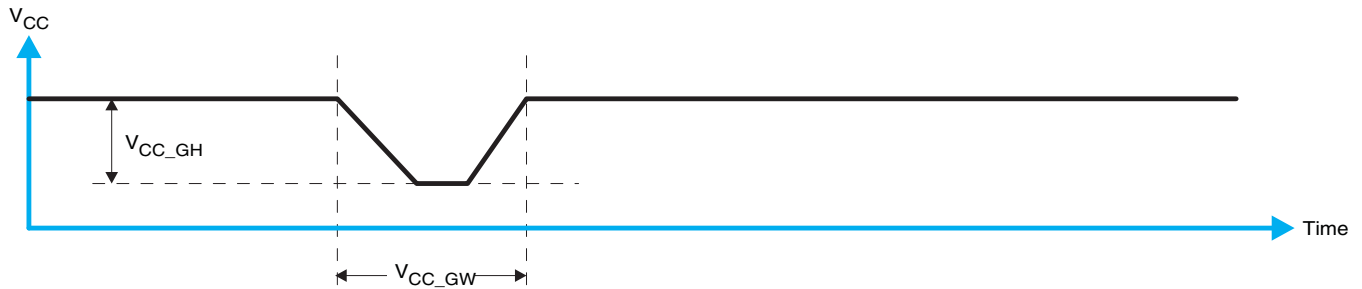

Figure 34. Glitch Width And Glitch Height

$V_{POR}$  is critical to the power-on reset.  $V_{POR}$  is the voltage level at which the reset condition is released and all the registers and the I<sup>2</sup>C/SMBus state machine are initialized to their default states. The value of  $V_{POR}$  differs based on the  $V_{CC}$  being lowered to or from 0. Figure 35 and Table 9 provide more details on this specification.

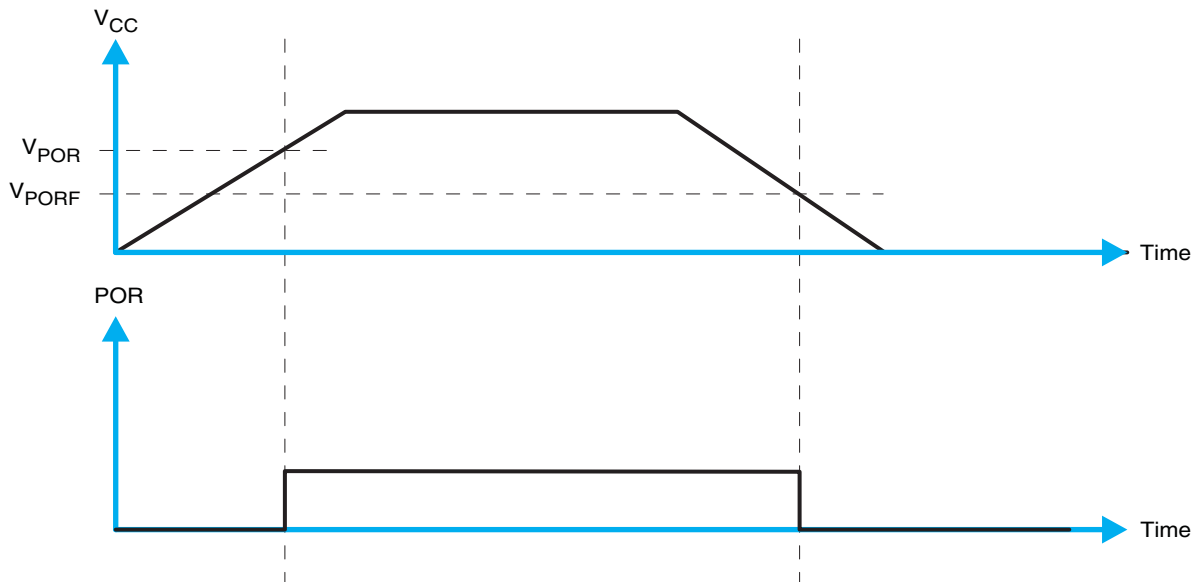

Figure 35.  $V_{POR}$

## 11 Device and Documentation Support

### 11.1 Trademarks

All trademarks are the property of their respective owners.

### 11.2 Electrostatic Discharge Caution



These devices have limited built-in ESD protection. The leads should be shorted together or the device placed in conductive foam during storage or handling to prevent electrostatic damage to the MOS gates.

### 11.3 Glossary

[SLYZ022](#) — *TI Glossary*.

This glossary lists and explains terms, acronyms, and definitions.

## 12 Mechanical, Packaging, and Orderable Information

The following pages include mechanical, packaging, and orderable information. This information is the most current data available for the designated devices. This data is subject to change without notice and revision of this document. For browser-based versions of this data sheet, refer to the left-hand navigation.

**PACKAGING INFORMATION**

Orderable Device	Status (1)	Package Type	Package Drawing	Pins	Package Qty	Eco Plan (2)	Lead/Ball Finish (6)	MSL Peak Temp (3)	Op Temp (°C)	Device Marking (4/5)	Samples
TCA6416PW	NRND	TSSOP	PW	24	60	Green (RoHS & no Sb/Br)	CU NIPDAU	Level-1-260C-UNLIM	-40 to 85	PH416	
TCA6416PWG4	NRND	TSSOP	PW	24	60	Green (RoHS & no Sb/Br)	CU NIPDAU	Level-1-260C-UNLIM	-40 to 85	PH416	
TCA6416PWR	NRND	TSSOP	PW	24	2000	Green (RoHS & no Sb/Br)	CU NIPDAU	Level-1-260C-UNLIM	-40 to 85	PH416	
TCA6416PWT	NRND	TSSOP	PW	24	250	Green (RoHS & no Sb/Br)	CU NIPDAU	Level-1-260C-UNLIM	-40 to 85	PH416	
TCA6416RTWR	NRND	WQFN	RTW	24	3000	Green (RoHS & no Sb/Br)	CU NIPDAU	Level-2-260C-1 YEAR	-40 to 85	PH416	
TCA6416RTWT	NRND	WQFN	RTW	24	250	Green (RoHS & no Sb/Br)	CU NIPDAU	Level-2-260C-1 YEAR	-40 to 85	PH416	
TCA6416ZQSR	NRND	BGA MICROSTAR JUNIOR	ZQS	24	2500	Green (RoHS & no Sb/Br)	SNAGCU	Level-1-260C-UNLIM	-40 to 85	PH416	

(1) The marketing status values are defined as follows:

**ACTIVE:** Product device recommended for new designs.

**LIFEBUY:** TI has announced that the device will be discontinued, and a lifetime-buy period is in effect.

**NRND:** Not recommended for new designs. Device is in production to support existing customers, but TI does not recommend using this part in a new design.

**PREVIEW:** Device has been announced but is not in production. Samples may or may not be available.

**OBSOLETE:** TI has discontinued the production of the device.

(2) Eco Plan - The planned eco-friendly classification: Pb-Free (RoHS), Pb-Free (RoHS Exempt), or Green (RoHS & no Sb/Br) - please check <http://www.ti.com/productcontent> for the latest availability information and additional product content details.

**TBD:** The Pb-Free/Green conversion plan has not been defined.

**Pb-Free (RoHS):** TI's terms "Lead-Free" or "Pb-Free" mean semiconductor products that are compatible with the current RoHS requirements for all 6 substances, including the requirement that lead not exceed 0.1% by weight in homogeneous materials. Where designed to be soldered at high temperatures, TI Pb-Free products are suitable for use in specified lead-free processes.

**Pb-Free (RoHS Exempt):** This component has a RoHS exemption for either 1) lead-based flip-chip solder bumps used between the die and package, or 2) lead-based die adhesive used between the die and leadframe. The component is otherwise considered Pb-Free (RoHS compatible) as defined above.

**Green (RoHS & no Sb/Br):** TI defines "Green" to mean Pb-Free (RoHS compatible), and free of Bromine (Br) and Antimony (Sb) based flame retardants (Br or Sb do not exceed 0.1% by weight in homogeneous material)

(3) MSL, Peak Temp. - The Moisture Sensitivity Level rating according to the JEDEC industry standard classifications, and peak solder temperature.

(4) There may be additional marking, which relates to the logo, the lot trace code information, or the environmental category on the device.

<sup>(5)</sup> Multiple Device Markings will be inside parentheses. Only one Device Marking contained in parentheses and separated by a "~" will appear on a device. If a line is indented then it is a continuation of the previous line and the two combined represent the entire Device Marking for that device.

<sup>(6)</sup> Lead/Ball Finish - Orderable Devices may have multiple material finish options. Finish options are separated by a vertical ruled line. Lead/Ball Finish values may wrap to two lines if the finish value exceeds the maximum column width.

**Important Information and Disclaimer:** The information provided on this page represents TI's knowledge and belief as of the date that it is provided. TI bases its knowledge and belief on information provided by third parties, and makes no representation or warranty as to the accuracy of such information. Efforts are underway to better integrate information from third parties. TI has taken and continues to take reasonable steps to provide representative and accurate information but may not have conducted destructive testing or chemical analysis on incoming materials and chemicals. TI and TI suppliers consider certain information to be proprietary, and thus CAS numbers and other limited information may not be available for release.

In no event shall TI's liability arising out of such information exceed the total purchase price of the TI part(s) at issue in this document sold by TI to Customer on an annual basis.

## TAPE AND REEL INFORMATION



### QUADRANT ASSIGNMENTS FOR PIN 1 ORIENTATION IN TAPE



\*All dimensions are nominal

Device	Package Type	Package Drawing	Pins	SPQ	Reel Diameter (mm)	Reel Width W1 (mm)	A0 (mm)	B0 (mm)	K0 (mm)	P1 (mm)	W (mm)	Pin1 Quadrant
TCA6416PWR	TSSOP	PW	24	2000	330.0	16.4	6.95	8.3	1.6	8.0	16.0	Q1
TCA6416PWT	TSSOP	PW	24	250	330.0	16.4	6.95	8.3	1.6	8.0	16.0	Q1
TCA6416RTWR	WQFN	RTW	24	3000	330.0	12.4	4.25	4.25	1.15	8.0	12.0	Q2
TCA6416RTWT	WQFN	RTW	24	250	180.0	12.4	4.25	4.25	1.15	8.0	12.0	Q2
TCA6416ZQSR	BGA MICROSTAR JUNIOR	ZQS	24	2500	330.0	12.4	3.3	3.3	1.6	8.0	12.0	Q1

**TAPE AND REEL BOX DIMENSIONS**

\*All dimensions are nominal

Device	Package Type	Package Drawing	Pins	SPQ	Length (mm)	Width (mm)	Height (mm)
TCA6416PWR	TSSOP	PW	24	2000	367.0	367.0	38.0
TCA6416PWT	TSSOP	PW	24	250	367.0	367.0	38.0
TCA6416RTWR	WQFN	RTW	24	3000	367.0	367.0	35.0
TCA6416RTWT	WQFN	RTW	24	250	210.0	185.0	35.0
TCA6416ZQSR	BGA MICROSTAR JUNIOR	ZQS	24	2500	338.1	338.1	20.6

ZQS (S-PBGA-N24)

PLASTIC BALL GRID ARRAY

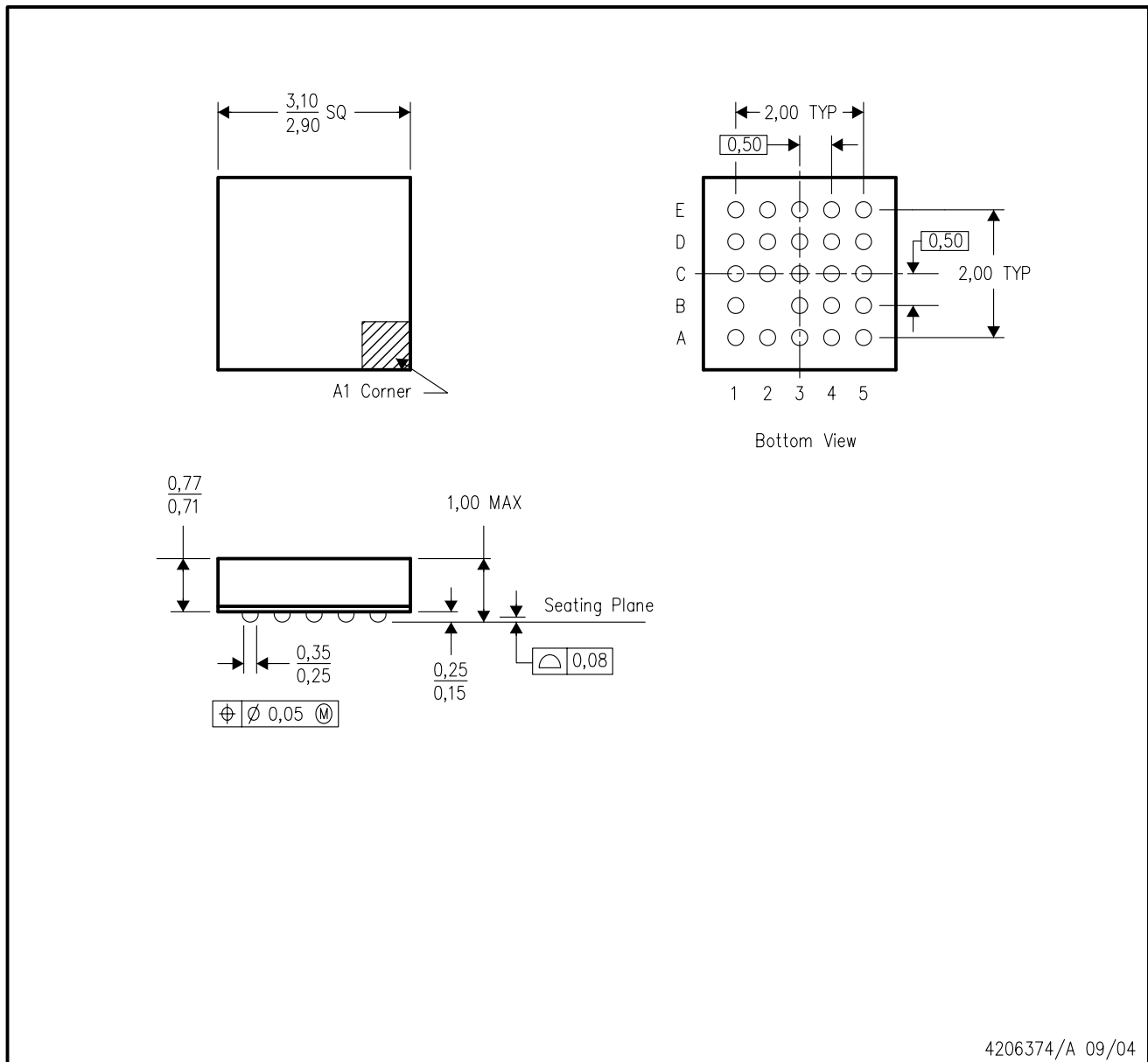



- NOTES:
- A. All linear dimensions are in millimeters.
  - B. This drawing is subject to change without notice.
  - C. Falls within JEDEC MO-225
  - D. This package is lead-free.

PW (R-PDSO-G24)

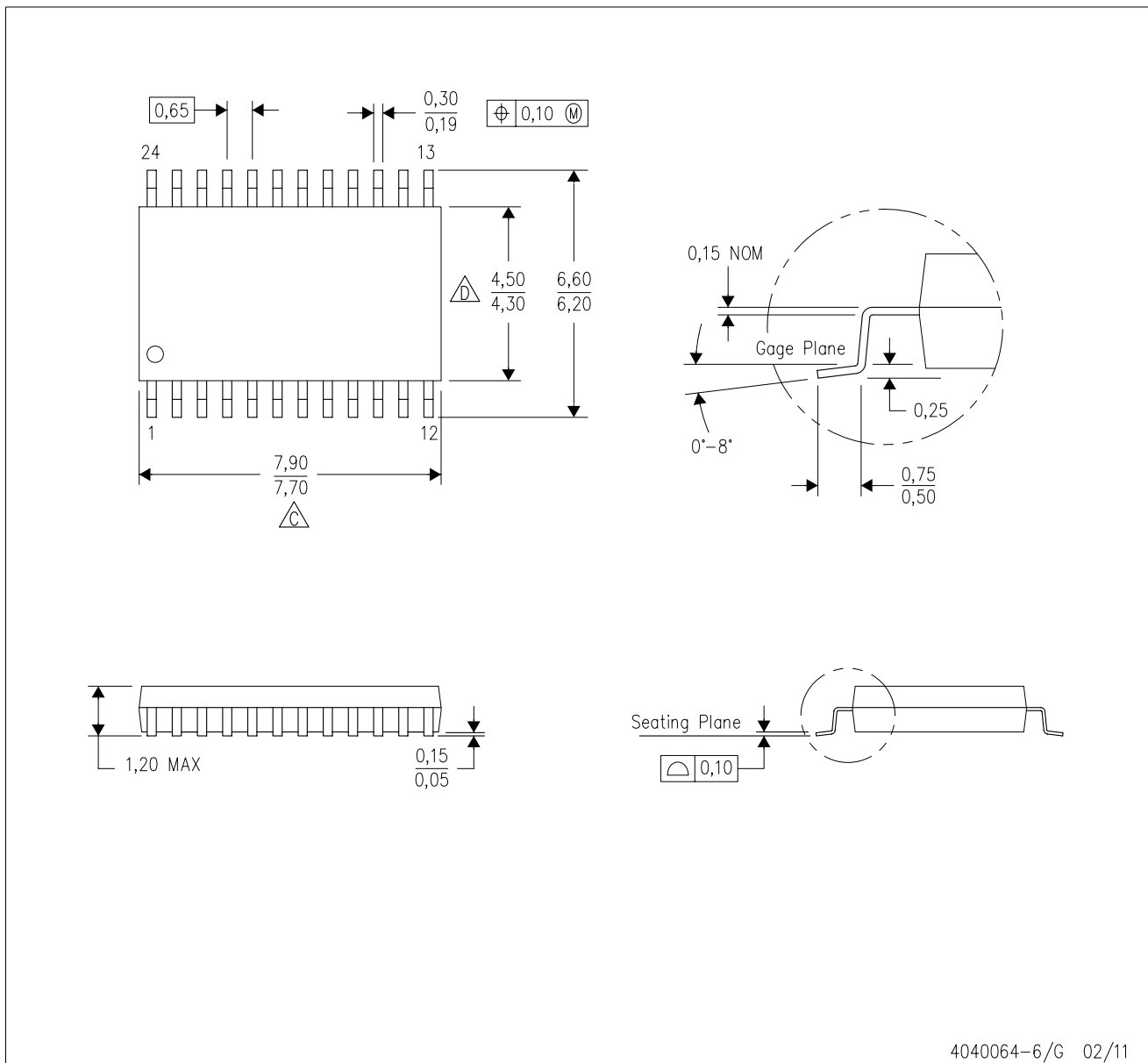
PLASTIC SMALL OUTLINE



4040064-6/G 02/11

- NOTES:
- A. All linear dimensions are in millimeters. Dimensioning and tolerancing per ASME Y14.5M-1994.
  - B. This drawing is subject to change without notice.
  -  C. Body length does not include mold flash, protrusions, or gate burrs. Mold flash, protrusions, or gate burrs shall not exceed 0,15 each side.
  -  D. Body width does not include interlead flash. Interlead flash shall not exceed 0,25 each side.
  - E. Falls within JEDEC MO-153

PW (R-PDSO-G24)

PLASTIC SMALL OUTLINE

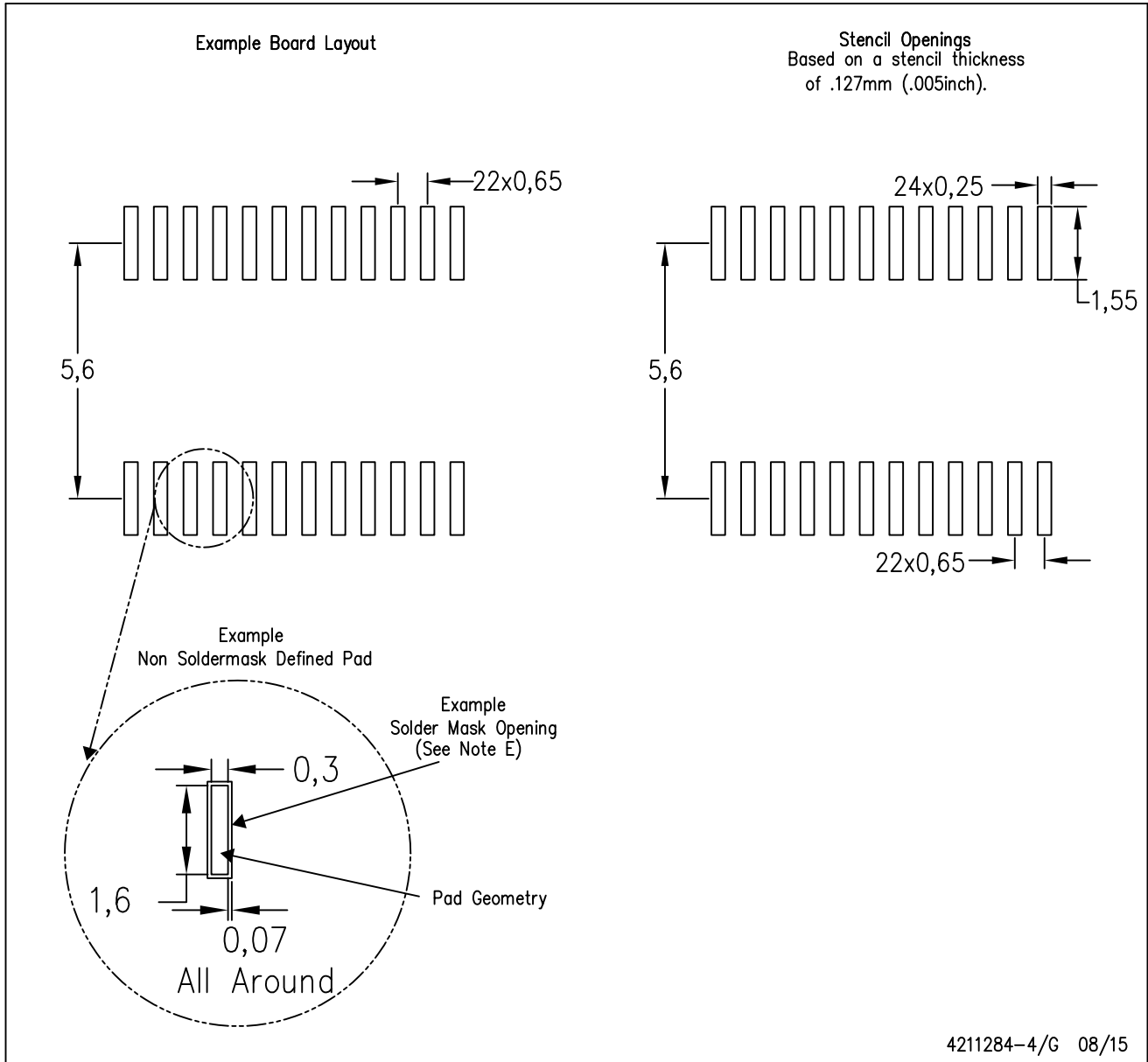

4211284-4/G 08/15

- NOTES:
- A. All linear dimensions are in millimeters.
  - B. This drawing is subject to change without notice.
  - C. Publication IPC-7351 is recommended for alternate design.
  - D. Laser cutting apertures with trapezoidal walls and also rounding corners will offer better paste release. Customers should contact their board assembly site for stencil design recommendations. Refer to IPC-7525 for other stencil recommendations.
  - E. Customers should contact their board fabrication site for solder mask tolerances between and around signal pads.

RTW (S-PWQFN-N24)

PLASTIC QUAD FLATPACK NO-LEAD

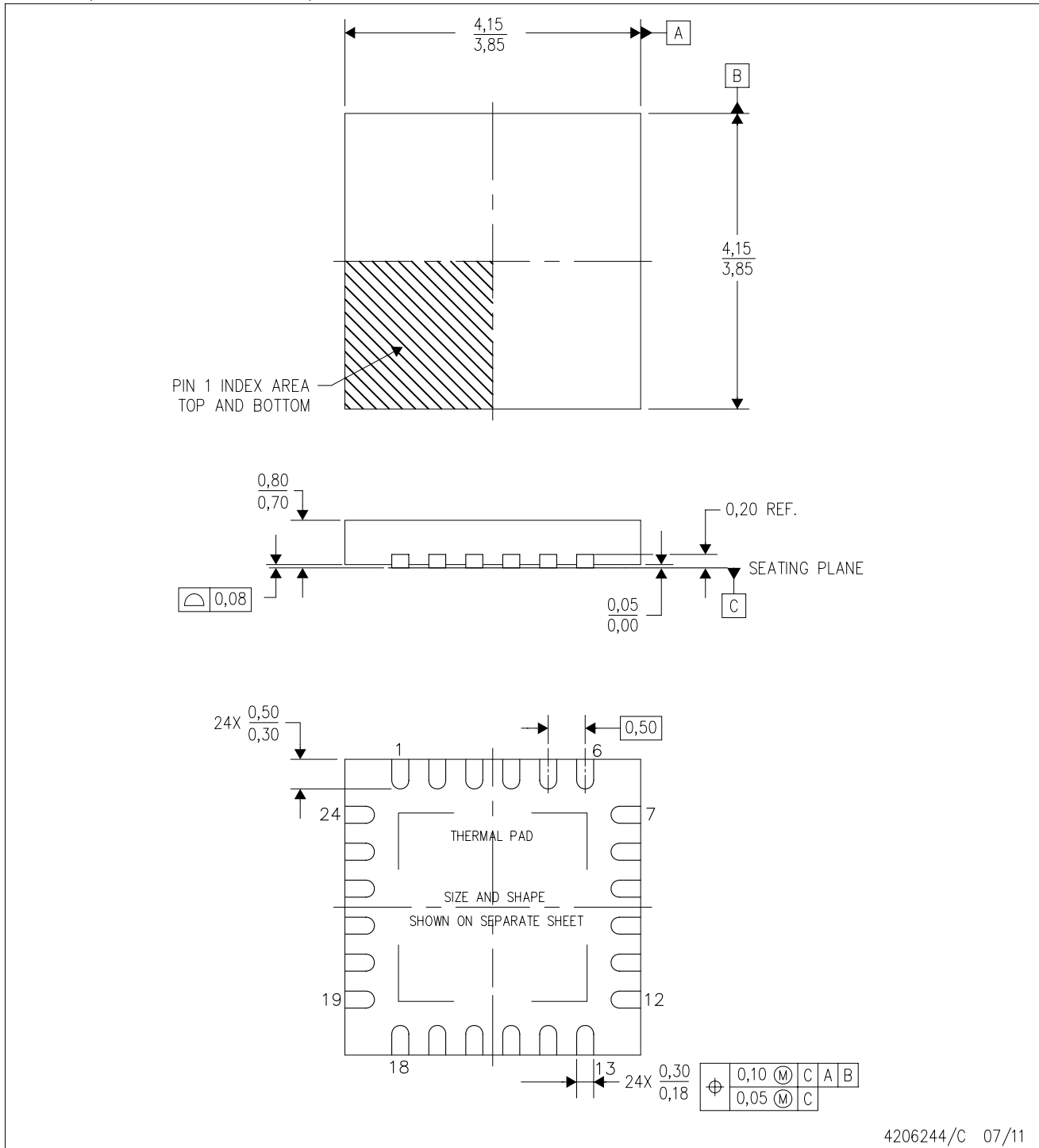

4206244/C 07/11

- NOTES:
- All linear dimensions are in millimeters. Dimensioning and tolerancing per ASME Y14.5M-1994.
  - This drawing is subject to change without notice.
  - Quad Flatpack, No-Leads (QFN) package configuration.
  - The package thermal pad must be soldered to the board for thermal and mechanical performance.
  - See the additional figure in the Product Data Sheet for details regarding the exposed thermal pad features and dimensions.
  - Falls within JEDEC MO-220.

THERMAL INFORMATION

This package incorporates an exposed thermal pad that is designed to be attached directly to an external heatsink. The thermal pad must be soldered directly to the printed circuit board (PCB). After soldering, the PCB can be used as a heatsink. In addition, through the use of thermal vias, the thermal pad can be attached directly to the appropriate copper plane shown in the electrical schematic for the device, or alternatively, can be attached to a special heatsink structure designed into the PCB. This design optimizes the heat transfer from the integrated circuit (IC).

For information on the Quad Flatpack No-Lead (QFN) package and its advantages, refer to Application Report, QFN/SON PCB Attachment, Texas Instruments Literature No. SLUA271. This document is available at [www.ti.com](http://www.ti.com).

The exposed thermal pad dimensions for this package are shown in the following illustration.

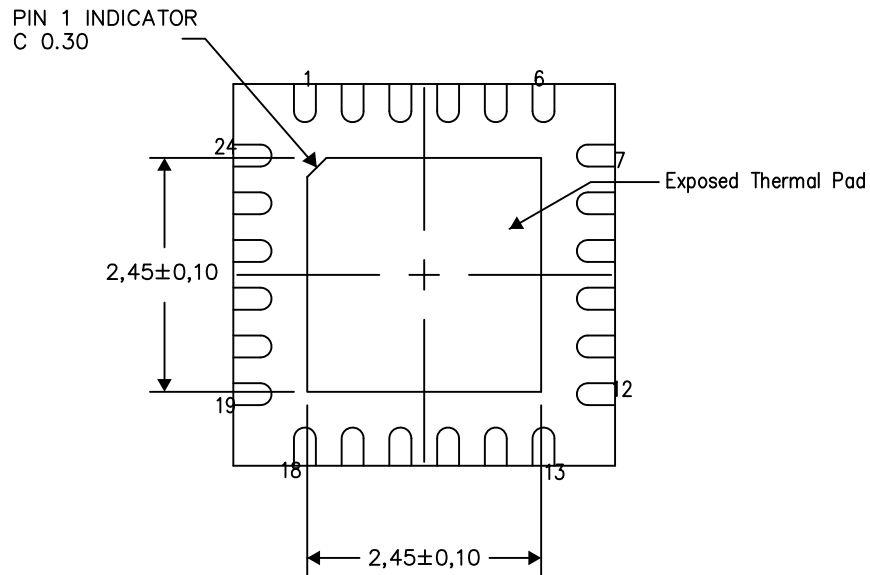

Bottom View  
Exposed Thermal Pad Dimensions

4206249-3/P 05/15

NOTES: A. All linear dimensions are in millimeters

RTW (S-PWQFN-N24)

PLASTIC QUAD FLATPACK NO-LEAD

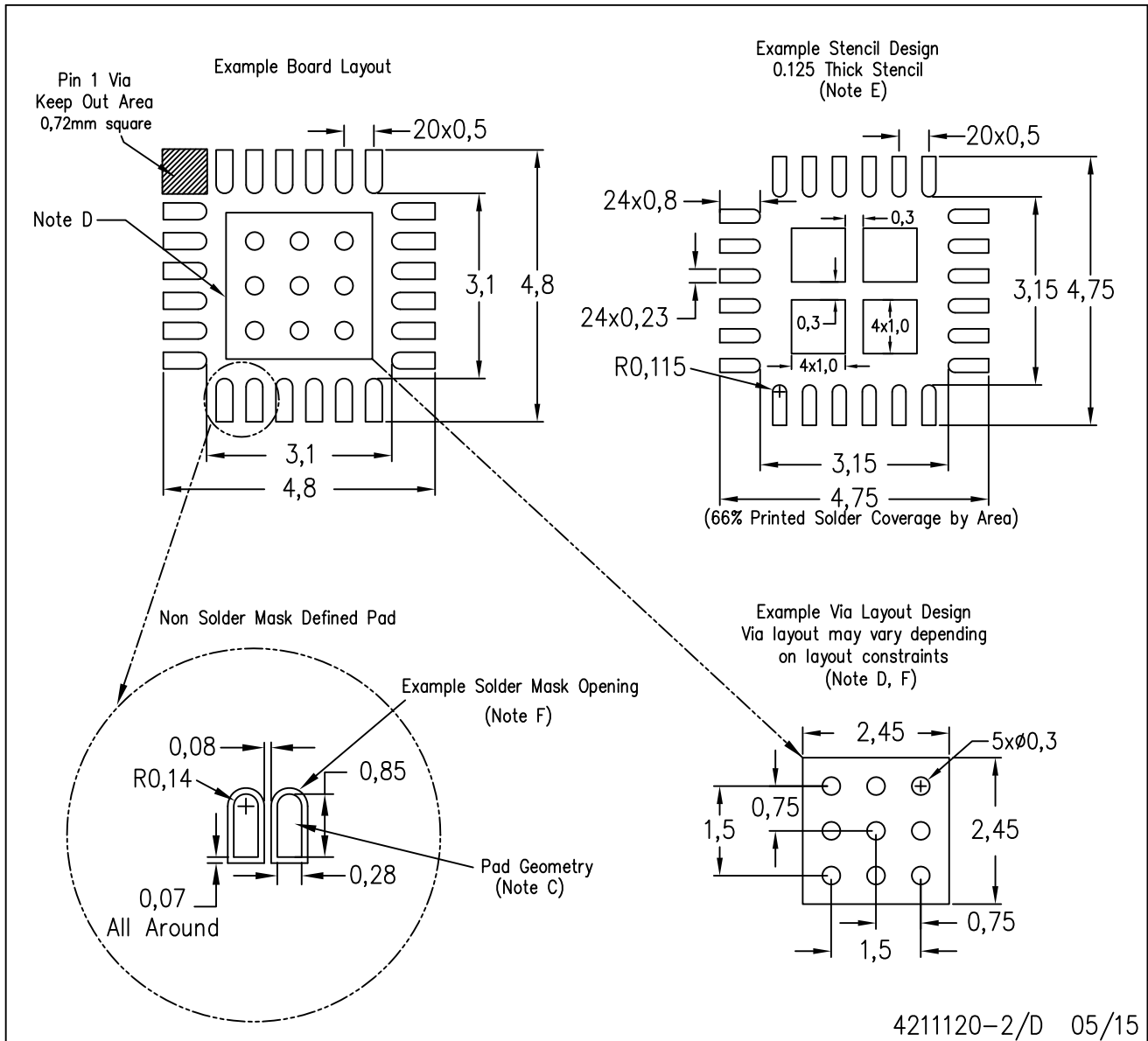

- NOTES:
- All linear dimensions are in millimeters.
  - This drawing is subject to change without notice.
  - Publication IPC-7351 is recommended for alternate designs.
  - This package is designed to be soldered to a thermal pad on the board. Refer to Application Note, Quad Flat-Pack Packages, Texas Instruments Literature No. SLUA271, and also the Product Data Sheets for specific thermal information, via requirements, and recommended board layout. These documents are available at [www.ti.com](http://www.ti.com) <<http://www.ti.com>>.
  - Laser cutting apertures with trapezoidal walls and also rounding corners will offer better paste release. Customers should contact their board assembly site for stencil design recommendations. Refer to IPC 7525 for stencil design considerations.
  - Customers should contact their board fabrication site for recommended solder mask tolerances and via tenting recommendations for vias placed in the thermal pad.

## IMPORTANT NOTICE

Texas Instruments Incorporated and its subsidiaries (TI) reserve the right to make corrections, enhancements, improvements and other changes to its semiconductor products and services per JESD46, latest issue, and to discontinue any product or service per JESD48, latest issue. Buyers should obtain the latest relevant information before placing orders and should verify that such information is current and complete. All semiconductor products (also referred to herein as "components") are sold subject to TI's terms and conditions of sale supplied at the time of order acknowledgment.

TI warrants performance of its components to the specifications applicable at the time of sale, in accordance with the warranty in TI's terms and conditions of sale of semiconductor products. Testing and other quality control techniques are used to the extent TI deems necessary to support this warranty. Except where mandated by applicable law, testing of all parameters of each component is not necessarily performed.

TI assumes no liability for applications assistance or the design of Buyers' products. Buyers are responsible for their products and applications using TI components. To minimize the risks associated with Buyers' products and applications, Buyers should provide adequate design and operating safeguards.

TI does not warrant or represent that any license, either express or implied, is granted under any patent right, copyright, mask work right, or other intellectual property right relating to any combination, machine, or process in which TI components or services are used. Information published by TI regarding third-party products or services does not constitute a license to use such products or services or a warranty or endorsement thereof. Use of such information may require a license from a third party under the patents or other intellectual property of the third party, or a license from TI under the patents or other intellectual property of TI.

Reproduction of significant portions of TI information in TI data books or data sheets is permissible only if reproduction is without alteration and is accompanied by all associated warranties, conditions, limitations, and notices. TI is not responsible or liable for such altered documentation. Information of third parties may be subject to additional restrictions.

Resale of TI components or services with statements different from or beyond the parameters stated by TI for that component or service voids all express and any implied warranties for the associated TI component or service and is an unfair and deceptive business practice. TI is not responsible or liable for any such statements.

Buyer acknowledges and agrees that it is solely responsible for compliance with all legal, regulatory and safety-related requirements concerning its products, and any use of TI components in its applications, notwithstanding any applications-related information or support that may be provided by TI. Buyer represents and agrees that it has all the necessary expertise to create and implement safeguards which anticipate dangerous consequences of failures, monitor failures and their consequences, lessen the likelihood of failures that might cause harm and take appropriate remedial actions. Buyer will fully indemnify TI and its representatives against any damages arising out of the use of any TI components in safety-critical applications.

In some cases, TI components may be promoted specifically to facilitate safety-related applications. With such components, TI's goal is to help enable customers to design and create their own end-product solutions that meet applicable functional safety standards and requirements. Nonetheless, such components are subject to these terms.

No TI components are authorized for use in FDA Class III (or similar life-critical medical equipment) unless authorized officers of the parties have executed a special agreement specifically governing such use.

Only those TI components which TI has specifically designated as military grade or "enhanced plastic" are designed and intended for use in military/aerospace applications or environments. Buyer acknowledges and agrees that any military or aerospace use of TI components which have **not** been so designated is solely at the Buyer's risk, and that Buyer is solely responsible for compliance with all legal and regulatory requirements in connection with such use.

TI has specifically designated certain components as meeting ISO/TS16949 requirements, mainly for automotive use. In any case of use of non-designated products, TI will not be responsible for any failure to meet ISO/TS16949.

### Products

Audio	<a href="http://www.ti.com/audio">www.ti.com/audio</a>
Amplifiers	<a href="http://amplifier.ti.com">amplifier.ti.com</a>
Data Converters	<a href="http://dataconverter.ti.com">dataconverter.ti.com</a>
DLP® Products	<a href="http://www.dlp.com">www.dlp.com</a>
DSP	<a href="http://dsp.ti.com">dsp.ti.com</a>
Clocks and Timers	<a href="http://www.ti.com/clocks">www.ti.com/clocks</a>
Interface	<a href="http://interface.ti.com">interface.ti.com</a>
Logic	<a href="http://logic.ti.com">logic.ti.com</a>
Power Mgmt	<a href="http://power.ti.com">power.ti.com</a>
Microcontrollers	<a href="http://microcontroller.ti.com">microcontroller.ti.com</a>
RFID	<a href="http://www.ti-rfid.com">www.ti-rfid.com</a>
OMAP Applications Processors	<a href="http://www.ti.com/omap">www.ti.com/omap</a>
Wireless Connectivity	<a href="http://www.ti.com/wirelessconnectivity">www.ti.com/wirelessconnectivity</a>

### Applications

Automotive and Transportation	<a href="http://www.ti.com/automotive">www.ti.com/automotive</a>
Communications and Telecom	<a href="http://www.ti.com/communications">www.ti.com/communications</a>
Computers and Peripherals	<a href="http://www.ti.com/computers">www.ti.com/computers</a>
Consumer Electronics	<a href="http://www.ti.com/consumer-apps">www.ti.com/consumer-apps</a>
Energy and Lighting	<a href="http://www.ti.com/energy">www.ti.com/energy</a>
Industrial	<a href="http://www.ti.com/industrial">www.ti.com/industrial</a>
Medical	<a href="http://www.ti.com/medical">www.ti.com/medical</a>
Security	<a href="http://www.ti.com/security">www.ti.com/security</a>
Space, Avionics and Defense	<a href="http://www.ti.com/space-avionics-defense">www.ti.com/space-avionics-defense</a>
Video and Imaging	<a href="http://www.ti.com/video">www.ti.com/video</a>

### TI E2E Community

[e2e.ti.com](http://e2e.ti.com)