

# TCA9406 2-Bit Bidirectional 1-MHz, I<sup>2</sup>C Bus and SMBus Voltage-Level Translator With 8-kV HBM ESD

## 1 Features

- 2-Bit Bidirectional Translator for SDA and SCL Lines in I<sup>2</sup>C Applications
- Provides Bidirectional Voltage Translation With No Direction Pin
- High-Impedance Output SCL\_A, SDA\_A, SCL\_B, SDA\_B Pins When OE = Low or V<sub>CC</sub> = 0 V
- Internal 10-kΩ Pullup Resistor on All SDA and SCL Pins
- 1.65 V to 3.6 V on A port and 2.3 V to 5.5 V on B port (V<sub>CCA</sub> ≤ V<sub>CCB</sub>)
- V<sub>CC</sub> Isolation Feature: If Either V<sub>CC</sub> Input Is at GND, Both Ports Are in the High-Impedance State
- No Power-Supply Sequencing Required: Either V<sub>CCA</sub> or V<sub>CCB</sub> Can Be Ramped First
- Low I<sub>off</sub> of 2 μA When Either V<sub>CCA</sub> or V<sub>CCB</sub> = 0 V
- OE Input Can Be Tied Directly to V<sub>CCA</sub> Or Controlled By GPIO
- Latch-Up Performance Exceeds 100 mA Per JESD 78, Class II
- ESD Protection Exceeds JESD 22
  - A Port
    - 2500-V Human-Body Model (A114-B)
    - 250-V Machine Model (A115-A)
    - 1500-V Charged-Device Model (C101)
  - B Port
    - 8-kV Human-Body Model (A114-B)
    - 250-V Machine Model (A115-A)
    - 1500-V Charged-Device Model (C101)

## 2 Applications

- I<sup>2</sup>C/SMBus
- UART
- GPIO

## 3 Description

The TCA9406 is a 2-bit bidirectional I<sup>2</sup>C and SMBus voltage-level translator with an output enable (OE) input. It is operational from 1.65 V to 3.6 V on the A-side, referenced to V<sub>CCA</sub>, and from 2.3 V to 5.5 V on the B-side, referenced to V<sub>CCB</sub>. This allows the device to interface between lower and higher logic signal levels at any of the typical 1.8-V, 2.5-V, 3.3-V, and 5-V supply rails.

The OE input pin is referenced to V<sub>CCA</sub>, can be tied directly to V<sub>CCA</sub>, but it is also 5.5-V tolerant. The OE pin can also be controlled and set to a logic low to place all the SCL and SDA pins in a high-impedance state, which significantly reduces the quiescent current consumption.

Under normal I<sup>2</sup>C and SMBus operation or other open-drain configurations, the TCA9406 can support up to 2Mbps; therefore, it is compatible with standard I<sup>2</sup>C speeds where the frequency of SCL is 100 kHz (Standard-mode), 400 kHz (Fast-mode), or 1 MHz (Fast-mode Plus). The device can also be used as a general purpose level translator, and when the A- and B-side ports are both driven with push-pull devices the TCA9406 can support up to 24 Mbps.

The TCA9406 features internal 10-kΩ pullup resistors on SCL\_A, SDA\_A, SCL\_B, and SDA\_B. Additional external pullup resistors can be added to the bus to reduce the total pullup resistance and speed up rising edges.

### Device Information<sup>(1)</sup>

PART NUMBER	PACKAGE	BODY SIZE (NOM)
TCA9406	SM8 (8)	2.95 mm × 2.80 mm
	US8 (8)	2.30 mm × 2.00 mm
	DSBGA (8)	1.90 mm × 0.90 mm

(1) For all available packages, see the orderable addendum at the end of the datasheet.

Typical Application Block Diagram for TCA9406

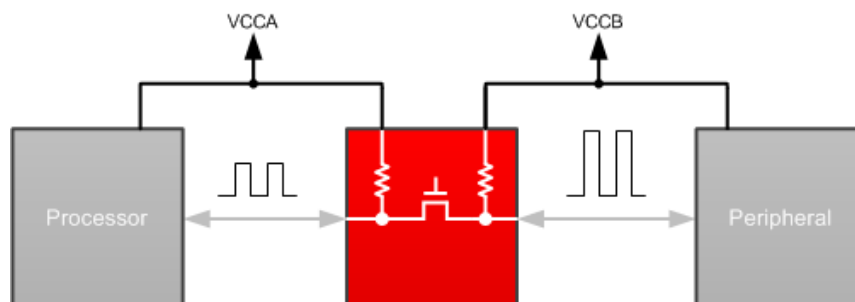

## Table of Contents

<b>1 Features</b> .....	<b>1</b>	<b>7 Parameter Measurement Information</b> .....	<b>12</b>
<b>2 Applications</b> .....	<b>1</b>	<b>8 Detailed Description</b> .....	<b>13</b>
<b>3 Description</b> .....	<b>1</b>	8.1 Overview .....	13
<b>4 Revision History</b> .....	<b>2</b>	8.2 Functional Block Diagram .....	13
<b>5 Pin Configuration and Functions</b> .....	<b>3</b>	8.3 Feature Description .....	13
<b>6 Specifications</b> .....	<b>4</b>	8.4 Device Functional Modes .....	15
6.1 Absolute Maximum Ratings .....	4	<b>9 Application and Implementation</b> .....	<b>16</b>
6.2 ESD Ratings .....	4	9.1 Application Information .....	16
6.3 Recommended Operating Conditions .....	5	9.2 Typical Application .....	16
6.4 Thermal Information .....	5	<b>10 Power Supply Recommendations</b> .....	<b>18</b>
6.5 Electrical Characteristics .....	6	<b>11 Layout</b> .....	<b>18</b>
6.6 Timing Requirements ( $V_{CCA} = 1.8\text{ V} \pm 0.15\text{ V}$ ) .....	7	11.1 Layout Guidelines .....	18
6.7 Timing Requirements ( $V_{CCA} = 2.5\text{ V} \pm 0.2\text{ V}$ ) .....	7	11.2 Layout Example .....	18
6.8 Timing Requirements ( $V_{CCA} = 3.3\text{ V} \pm 0.3\text{ V}$ ) .....	7	<b>12 Device and Documentation Support</b> .....	<b>19</b>
6.9 Switching Characteristics ( $V_{CCA} = 1.8\text{ V} \pm 0.15\text{ V}$ ) ...	8	12.1 Trademarks .....	19
6.10 Switching Characteristics ( $V_{CCA} = 2.5\text{ V} \pm 0.2\text{ V}$ ) ...	9	12.2 Electrostatic Discharge Caution .....	19
6.11 Switching Characteristics ( $V_{CCA} = 3.3\text{ V} \pm 0.3\text{ V}$ ) ..	10	12.3 Glossary .....	19
6.12 Typical Characteristics .....	11	<b>13 Mechanical, Packaging, and Orderable Information</b> .....	<b>19</b>

## 4 Revision History

NOTE: Page numbers for previous revisions may differ from page numbers in the current version.

### Changes from Revision B (June 2013) to Revision C

Page

- Added *Pin Configuration and Functions* section, *ESD Ratings* table, *Feature Description* section, *Device Functional Modes*, *Application and Implementation* section, *Power Supply Recommendations* section, *Layout* section, *Device and Documentation Support* section, and *Mechanical, Packaging, and Orderable Information* section ..... **1**

### Changes from Revision A (February 2013) to Revision B

Page

- Removed ordering information table, information now located in POA ..... **1**

## 5 Pin Configuration and Functions

**8-PIN SM8 OR US8  
(TOP VIEW)**

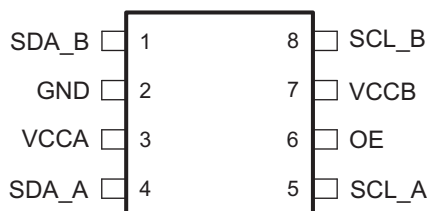

**8-PIN DSBGA  
(BOTTOM VIEW)**

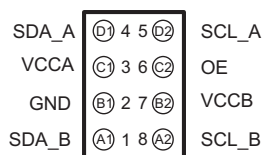

### Pin Functions

PIN			TYPE	DESCRIPTION
NAME	DCT, DCU	YZP		
SDA_B	1	A1	I/O	Input/output B. Referenced to $V_{CCB}$ .
GND	2	B1	GND	Ground
VCCA	3	C1	Power	A-port supply voltage. $1.65\text{ V} \leq V_{CCA} \leq 3.6\text{ V}$ and $V_{CCA} \leq V_{CCB}$
SDA_A	4	D1	I/O	Input/output A. Referenced to $V_{CCA}$ .
SCL_A	5	D2	I/O	Input/output A. Referenced to $V_{CCA}$ .
OE	6	C2	Input	Output enable (active High). Pull OE low to place all outputs in 3-state mode. Referenced to $V_{CCA}$ .
VCCB	7	B2	Power	B-port supply voltage. $2.3\text{ V} \leq V_{CCB} \leq 5.5\text{ V}$
SCL_B	8	A2	I/O	Input/output B. Referenced to $V_{CCB}$ .

## 6 Specifications

### 6.1 Absolute Maximum Ratings<sup>(1)</sup>

over recommended operating free-air temperature range (unless otherwise noted)

		MIN	MAX	UNIT	
V <sub>CCA</sub>	Supply voltage range	-0.5	4.6	V	
V <sub>CCB</sub>	Supply voltage range	-0.5	6.5	V	
V <sub>I</sub>	Input voltage range <sup>(2)</sup>	A port	-0.5	4.6	V
		B port	-0.5	6.5	
V <sub>O</sub>	Voltage range applied to any output in the high-impedance or power-off state <sup>(2)</sup>	A port	-0.5	4.6	V
		B port	-0.5	6.5	
V <sub>O</sub>	Voltage range applied to any output in the high or low state <sup>(2)(3)</sup>	A port	-0.5	V <sub>CCA</sub> + 0.5	V
		B port	-0.5	V <sub>CCB</sub> + 0.5	
I <sub>IK</sub>	Input clamp current	V <sub>I</sub> < 0	-50	mA	
I <sub>OK</sub>	Output clamp current	V <sub>O</sub> < 0	-50	mA	
I <sub>O</sub>	Continuous output current		±50	mA	
	Continuous current through V <sub>CCA</sub> , V <sub>CCB</sub> , or GND		±100	mA	
T <sub>stg</sub>	Storage temperature	-65	150	°C	

- (1) Stresses beyond those listed under *Absolute Maximum Ratings* may cause permanent damage to the device. These are stress ratings only, and functional operation of the device at these or any other conditions beyond those indicated under *Recommended Operating Conditions* is not implied. Exposure to absolute-maximum-rated conditions for extended periods may affect device reliability.
- (2) The input and output negative-voltage ratings may be exceeded if the input and output current ratings are observed.
- (3) The value of V<sub>CCA</sub> and V<sub>CCB</sub> are provided in the recommended operating conditions table.

### 6.2 ESD Ratings

		VALUE	UNIT	
V <sub>(ESD)</sub>	Electrostatic discharge	Human-body model (HBM), per ANSI/ESDA/JEDEC JS-001 <sup>(1)</sup>	±2500	V
		A-Port	±8000	
	Charged-device model (CDM), per JEDEC specification JESD22-C101 <sup>(2)</sup>	±1500		
	B-Port	±250		
	Machine model (MM), A115-A	±250		

- (1) JEDEC document JEP155 states that 500-V HBM allows safe manufacturing with a standard ESD control process.
- (2) JEDEC document JEP157 states that 250-V CDM allows safe manufacturing with a standard ESD control process.

### 6.3 Recommended Operating Conditions

$V_{CCI}$  is the supply voltage associated with the input port.  $V_{CCO}$  is the supply voltage associated with the output port.

		$V_{CCA}$	$V_{CCB}$	MIN	MAX	UNIT	
$V_{CCA}$	Supply voltage <sup>(1)</sup>			1.65	3.6	V	
$V_{CCB}$	Supply voltage			2.3	5.5	V	
$V_{IH}$	High-level input voltage	A-port I/Os	1.65 V to 1.95 V 2.3 V to 3.6 V	2.3 V to 5.5 V	$V_{CCI} - 0.2$	$V_{CCI}$	V
					$V_{CCI} - 0.4$	$V_{CCI}$	
		B-port I/Os OE input	1.65 V to 3.6 V	2.3 V to 5.5 V	$V_{CCI} - 0.4$ $V_{CCA} \times 0.65$	$V_{CCI}$ 5.5	
$V_{IL}$ <sup>(2)</sup>	Low-level input voltage	A-port I/Os	1.65 V to 3.6 V	2.3 V to 5.5 V	0	0.15	V
		B-port I/Os			0	0.15	
		OE input			0	$V_{CCA} \times 0.35$	
$\Delta t/\Delta v$	Input transition rise or fall rate	A-port I/Os, push-pull driving	1.65 V to 3.6 V	2.3 V to 5.5 V		10	ns/V
		B-port I/Os, push-pull driving				10	
		Control input				10	
$T_A$	Operating free-air temperature				-40	85	°C

(1)  $V_{CCA}$  must be less than or equal to  $V_{CCB}$  (except during power-on transient time), and  $V_{CCA}$  must not exceed 3.6 V.

(2) The maximum  $V_{IL}$  value is provided to ensure that a valid  $V_{OL}$  is maintained. The  $V_{OL}$  value is  $V_{IL}$  plus the voltage drop across the pass-gate transistor.

### 6.4 Thermal Information

THERMAL METRIC <sup>(1)</sup>		TCA9406			UNIT
		DCT	DCU	YZP	
		8 PINS	8 PINS	8 PINS	
$R_{\theta JA}$	Junction-to-ambient thermal resistance	182.6	199.1	105.8	°C/W
$R_{\theta JC(top)}$	Junction-to-case (top) thermal resistance	113.3	72.4	1.6	
$R_{\theta JB}$	Junction-to-board thermal resistance	94.9	77.8	10.8	
$\Psi_{JT}$	Junction-to-top characterization parameter	39.4	6.2	3.1	
$\Psi_{JB}$	Junction-to-board characterization parameter	93.9	77.4	10.8	

(1) For more information about traditional and new thermal metrics, see the *IC Package Thermal Metrics* application report, [SPRA953](#).

## 6.5 Electrical Characteristics<sup>(1)(2)(3)</sup>

over recommended operating free-air temperature range (unless otherwise noted)

PARAMETER	TEST CONDITIONS	V <sub>CCA</sub>	V <sub>CCB</sub>	T <sub>A</sub> = 25°C			–40°C to 85°C		UNIT
				MIN	TYP	MAX	MIN	MAX	
V <sub>OHA</sub>	I <sub>OH</sub> = –20 μA, V <sub>IB</sub> ≥ V <sub>CCB</sub> – 0.4 V	1.65 V to 3.6 V	2.3 V to 5.5 V				V <sub>CCA</sub> × 0.67		V
V <sub>OLA</sub>	I <sub>OL</sub> = 1 mA, V <sub>IB</sub> ≤ 0.15 V	1.65 V to 3.6 V	2.3 V to 5.5 V				0.4		V
V <sub>OHB</sub>	I <sub>OH</sub> = –20 μA, V <sub>IA</sub> ≥ V <sub>CCA</sub> – 0.2 V	1.65 V to 3.6 V	2.3 V to 5.5 V				V <sub>CCB</sub> × 0.67		V
V <sub>OLB</sub>	I <sub>OL</sub> = 1 mA, V <sub>IA</sub> ≤ 0.15 V	1.65 V to 3.6 V	2.3 V to 5.5 V				0.4		V
I <sub>I</sub>	OE	1.65 V to 3.6 V	2.3 V to 5.5 V			±1	±2		μA
I <sub>off</sub>	A port	0 V	0 V to 5.5 V			±1	±2		μA
	B port	0 to 3.6 V	0 V			±1	±2		μA
I <sub>OZ</sub>	A or B port	1.65 V to 3.6 V	2.3 V to 5.5 V			±1	±2		μA
I <sub>CCA</sub>	V <sub>I</sub> = V <sub>O</sub> = open, I <sub>O</sub> = 0	1.65 V to V <sub>CCB</sub>	2.3 V to 5.5 V				2.4		μA
		3.6 V	0 V				2.2		
		0 V	5.5 V				–1		
I <sub>CCB</sub>	V <sub>I</sub> = V <sub>O</sub> = open, I <sub>O</sub> = 0	1.65 V to V <sub>CCB</sub>	2.3 V to 5.5 V				12		μA
		3.6 V	0 V				–1		
		0 V	5.5 V				1		
I <sub>CCA</sub> + I <sub>CCB</sub>	V <sub>I</sub> = V <sub>CCI</sub> or GND, I <sub>O</sub> = 0	1.65 V to V <sub>CCB</sub>	2.3 V to 5.5 V				14.4		μA
C <sub>I</sub>	OE	3.3 V	3.3 V		2.5		3.5		pF
C <sub>IO</sub>	A or B port	3.3 V	3.3 V		10				pF
	A port				5		6		
	B port				6		7.5		

(1) V<sub>CCI</sub> is the V<sub>CC</sub> associated with the input port.

(2) V<sub>CCO</sub> is the V<sub>CC</sub> associated with the output port.

(3) V<sub>CCA</sub> must be less than or equal to V<sub>CCB</sub>, and V<sub>CCA</sub> must not exceed 3.6 V.

### 6.6 Timing Requirements ( $V_{CCA} = 1.8 \text{ V} \pm 0.15 \text{ V}$ )

over recommended operating free-air temperature range (unless otherwise noted)

			$V_{CCB} = 2.5 \text{ V} \pm 0.2 \text{ V}$		$V_{CC} = 3.3 \text{ V} \pm 0.3 \text{ V}$		$V_{CC} = 5 \text{ V} \pm 0.5 \text{ V}$		UNIT
			MIN	MAX	MIN	MAX	MIN	MAX	
Data rate	Push-pull driving		21		22		24		Mbps
	Open-drain driving		2		2		2		
$t_w$	Pulse duration	Push-pull driving	47		45		41		ns
		Open-drain driving	500		500		500		

### 6.7 Timing Requirements ( $V_{CCA} = 2.5 \text{ V} \pm 0.2 \text{ V}$ )

over recommended operating free-air temperature range (unless otherwise noted)

			$V_{CCB} = 2.5 \text{ V} \pm 0.2 \text{ V}$		$V_{CC} = 3.3 \text{ V} \pm 0.3 \text{ V}$		$V_{CC} = 5 \text{ V} \pm 0.5 \text{ V}$		UNIT
			MIN	MAX	MIN	MAX	MIN	MAX	
Data rate	Push-pull driving		20		22		24		Mbps
	Open-drain driving		2		2		2		
$t_w$	Pulse duration	Push-pull driving	50		45		41		ns
		Open-drain driving	500		500		500		

### 6.8 Timing Requirements ( $V_{CCA} = 3.3 \text{ V} \pm 0.3 \text{ V}$ )

over recommended operating free-air temperature range (unless otherwise noted)

			$V_{CC} = 3.3 \text{ V} \pm 0.3 \text{ V}$		$V_{CC} = 5 \text{ V} \pm 0.5 \text{ V}$		UNIT
			MIN	MAX	MIN	MAX	
Data rate	Push-pull driving		23		24		Mbps
	Open-drain driving		2		2		
$t_w$	Pulse duration	Push-pull driving	43		41		ns
		Open-drain driving	500		500		

## 6.9 Switching Characteristics ( $V_{CCA} = 1.8 \text{ V} \pm 0.15 \text{ V}$ )

over recommended operating free-air temperature range (unless otherwise noted)

PARAMETER	FROM (INPUT)	TO (OUTPUT)	TEST CONDITIONS	$V_{CCB} = 2.5 \text{ V} \pm 0.2 \text{ V}$		$V_{CCB} = 3.3 \text{ V} \pm 0.3 \text{ V}$		$V_{CCB} = 5 \text{ V} \pm 0.5 \text{ V}$		UNIT
				MIN	MAX	MIN	MAX	MIN	MAX	
$t_{PHL}$	A	B	Push-pull driving		5.3		5.4		6.8	ns
			Open-drain driving	2.3	8.8	2.4	9.6	2.6	10	
$t_{PLH}$			Push-pull driving		6.8		7.1		7.5	
			Open-drain driving	45	260	36	208	27	198	
$t_{PHL}$	B	A	Push-pull driving		4.4		4.5		4.7	ns
			Open-drain driving	1.9	5.3	1.1	4.4	1.2	4	
$t_{PLH}$			Push-pull driving		5.3		4.5		0.5	
			Open-drain driving	45	175	36	140	27	102	
$t_{en}$	OE	A or B			200		200		200	ns
$t_{dis}$	OE	A or B			50		40		35	ns
$t_{rA}$	A-port rise time		Push-pull driving	3.2	9.5	2.3	9.3	2	7.6	ns
			Open-drain driving	38	165	30	132	22	95	
$t_{rB}$	B-port rise time		Push-pull driving	4	10.8	2.7	9.1	2.7	7.6	ns
			Open-drain driving	34	145	23	106	10	58	
$t_{fA}$	A-port fall time		Push-pull driving	2	5.9	1.9	6	1.7	13.3	ns
			Open-drain driving	4.4	6.9	4.3	6.4	4.2	6.1	
$t_{fB}$	B-port fall time		Push-pull driving	2.9	13.8	2.8	16.2	2.8	16.2	ns
			Open-drain driving	6.9	13.8	7.5	16.2	7	16.2	
$t_{SK(O)}$	Channel-to-channel skew				0.7		0.7		0.7	ns
Max data rate			Push-pull driving		21		22		24	Mbps
			Open-drain driving		2		2		2	

## 6.10 Switching Characteristics ( $V_{CCA} = 2.5 \text{ V} \pm 0.2 \text{ V}$ )

over recommended operating free-air temperature range (unless otherwise noted)

PARAMETER	FROM (INPUT)	TO (OUTPUT)	TEST CONDITIONS	$V_{CCB} = 2.5 \text{ V} \pm 0.2 \text{ V}$		$V_{CCB} = 3.3 \text{ V} \pm 0.3 \text{ V}$		$V_{CCB} = 5 \text{ V} \pm 0.5 \text{ V}$		UNIT
				MIN	MAX	MIN	MAX	MIN	MAX	
$t_{PHL}$	A	B	Push-pull driving	3.2		3.7		3.8		ns
			Open-drain driving	1.7	6.3	2	6	2.1	5.8	
$t_{PLH}$			Push-pull driving	3.5		4.1		4.4		
			Open-drain driving	43	250	36	206	27	190	
$t_{PHL}$	B	A	Push-pull driving	3		3.6		4.3		ns
			Open-drain driving	1.8	4.7	2.6	4.2	1.2	4	
$t_{PLH}$			Push-pull driving	2.5		1.6		1		
			Open-drain driving	44	170	37	140	27	103	
$t_{en}$	OE	A or B		200		200		200		ns
$t_{dis}$	OE	A or B		50		40		35		ns
$t_{rA}$	A-port rise time		Push-pull driving	2.8	7.4	2.6	6.6	1.8	5.6	ns
			Open-drain driving	34	149	28	121	24	89	
$t_{rB}$	B-port rise time		Push-pull driving	3.2	8.3	2.9	7.2	2.4	6.1	ns
			Open-drain driving	35	151	24	112	12	64	
$t_{fA}$	A-port fall time		Push-pull driving	1.9	5.7	1.9	5.5	1.8	5.3	ns
			Open-drain driving	4.4	6.9	4.3	6.2	4.2	5.8	
$t_{fB}$	B-port fall time		Push-pull driving	2.2	7.8	2.4	6.7	2.6	6.6	ns
			Open-drain driving	5.1	8.8	5.4	9.4	5.4	10.4	
$t_{SK(O)}$	Channel-to-channel skew			0.7		0.7		0.7		ns
Max data rate			Push-pull driving	20		22		24		Mbps
			Open-drain driving	2		2		2		

## 6.11 Switching Characteristics ( $V_{CCA} = 3.3 \text{ V} \pm 0.3 \text{ V}$ )

over recommended operating free-air temperature range (unless otherwise noted)

PARAMETER	FROM (INPUT)	TO (OUTPUT)	TEST CONDITIONS	$V_{CCB} = 3.3 \text{ V} \pm 0.3 \text{ V}$		$V_{CCB} = 5 \text{ V} \pm 0.5 \text{ V}$		UNIT
				MIN	MAX	MIN	MAX	
$t_{PHL}$	A	B	Push-pull driving	2.4		3.1		ns
			Open-drain driving	1.3	4.2	1.4	4.6	
$t_{PLH}$			Push-pull driving	4.2		4.4		
			Open-drain driving	36	204	28	165	
$t_{PHL}$	B	A	Push-pull driving	2.5		3.3		ns
			Open-drain driving	1	124	1	97	
$t_{PLH}$			Push-pull driving	2.5		2.6		
			Open-drain driving	3	139	3	105	
$t_{en}$	OE	A or B		200		200		ns
$t_{dis}$	OE	A or B		40		35		ns
$t_{rA}$	A-port rise time		Push-pull driving	2.3	5.6	1.9	4.8	ns
			Open-drain driving	25	116	19	85	
$t_{rB}$	B-port rise time		Push-pull driving	2.5	6.4	2.1	7.4	ns
			Open-drain driving	26	116	14	72	
$t_{fA}$	A-port fall time		Push-pull driving	2	5.4	1.9	5	ns
			Open-drain driving	4.3	6.1	4.2	5.7	
$t_{fB}$	B-port fall time		Push-pull driving	2.3	7.4	2.4	7.6	ns
			Open-drain driving	5	7.6	4.8	8.3	
$t_{SK(O)}$	Channel-to-channel skew			0.7		0.7		ns
Max data rate			Push-pull driving	23		24		Mbps
			Open-drain driving	2		2		

## 6.12 Typical Characteristics

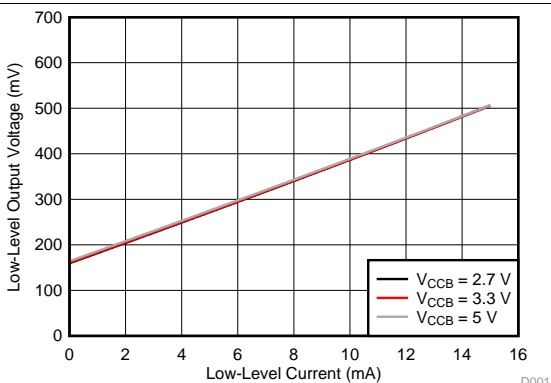

Figure 1. Low-Level Output Voltage ( $V_{OL(Bx)}$ ) vs Low-Level Current ( $I_{OL(Bx)}$ )

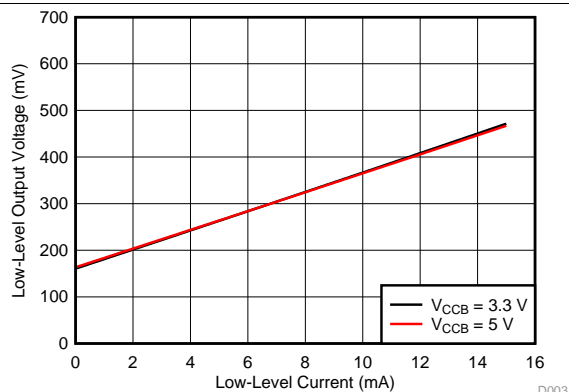

Figure 2. Low-Level Output Voltage ( $V_{OL(Bx)}$ ) vs Low-Level Current ( $I_{OL(Bx)}$ )

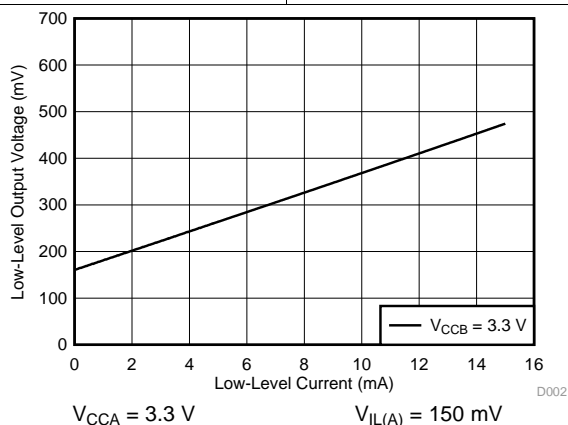
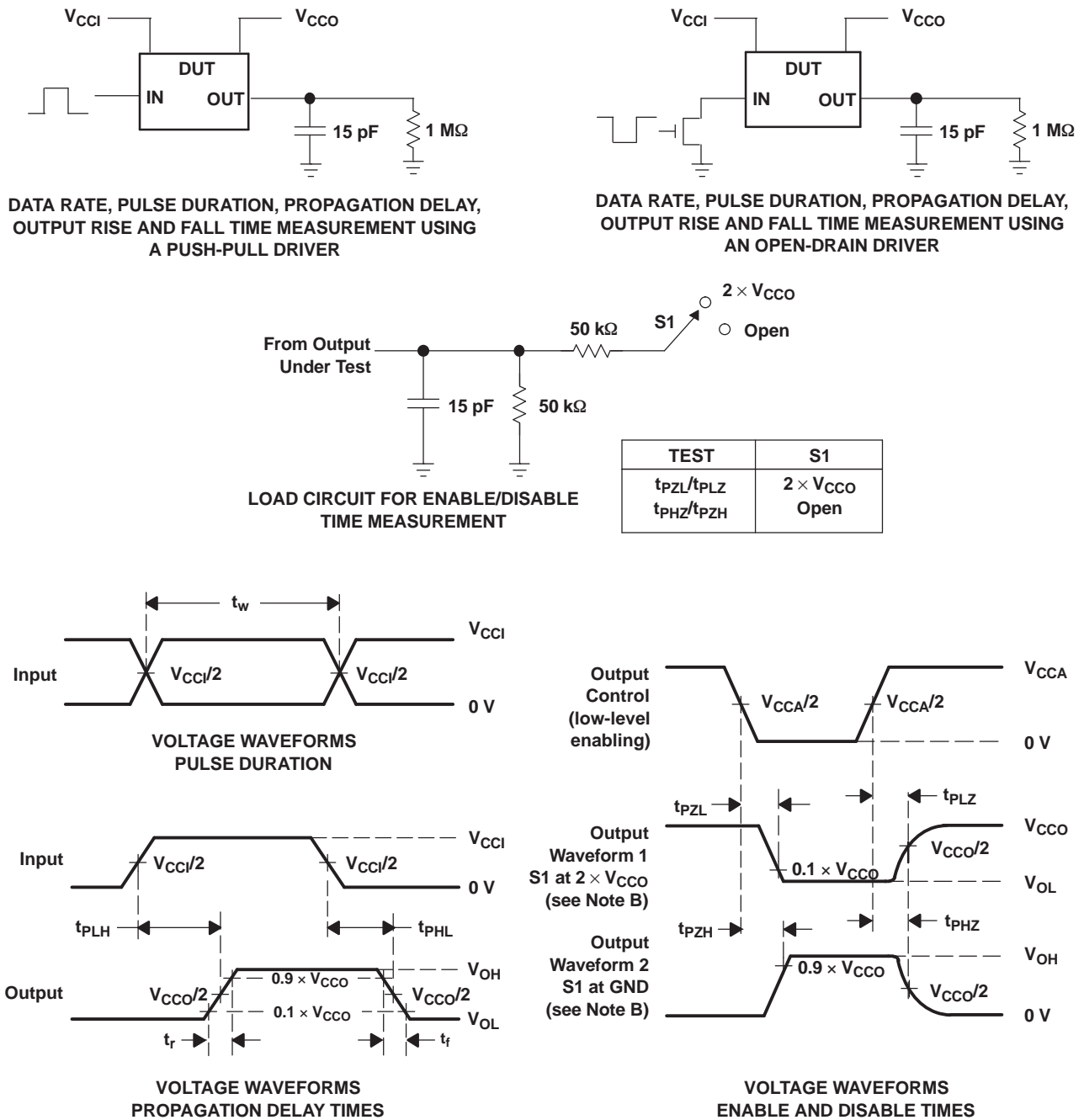

Figure 3. Low-Level Output Voltage ( $V_{OL(Bx)}$ ) vs Low-Level Current ( $I_{OL(Bx)}$ )

## 7 Parameter Measurement Information



- A.  $C_L$  includes probe and jig capacitance.
- B. Waveform 1 is for an output with internal conditions such that the output is low, except when disabled by the output control. Waveform 2 is for an output with internal conditions such that the output is high, except when disabled by the output control.
- C. All input pulses are supplied by generators having the following characteristics:  $PRR \leq 10$  MHz,  $Z_O = 50 \Omega$ ,  $dv/dt \geq 1$  V/ns.
- D. The outputs are measured one at a time, with one transition per measurement.
- E.  $t_{PLZ}$  and  $t_{PHZ}$  are the same as  $t_{dis}$ .
- F.  $t_{PZL}$  and  $t_{PZH}$  are the same as  $t_{en}$ .
- G.  $t_{PLH}$  and  $t_{PHL}$  are the same as  $t_{pd}$ .
- H.  $V_{CCI}$  is the  $V_{CC}$  associated with the input port.
- I.  $V_{CCO}$  is the  $V_{CC}$  associated with the output port.
- J. All parameters and waveforms are not applicable to all devices.

**Figure 4. Load Circuit and Voltage Waveforms**

## 8 Detailed Description

### 8.1 Overview

The TCA9406 device is a directionless voltage-level translator specifically designed for translating logic voltage levels. The A port is able to accept I/O voltages ranging from 1.65 V to 3.6 V, while the B port can accept I/O voltages from 2.3 V to 5.5 V. The device is a pass-gate architecture with edge-rate accelerators (one-shots) to improve the overall data rate. 10-k $\Omega$  pullup resistors, commonly used in open-drain applications, have been conveniently integrated so that an external resistor is not needed. While this device is designed for open-drain applications which makes it ideal for I<sup>2</sup>C and SMBus applications, the device can also translate push-pull CMOS logic outputs.

### 8.2 Functional Block Diagram

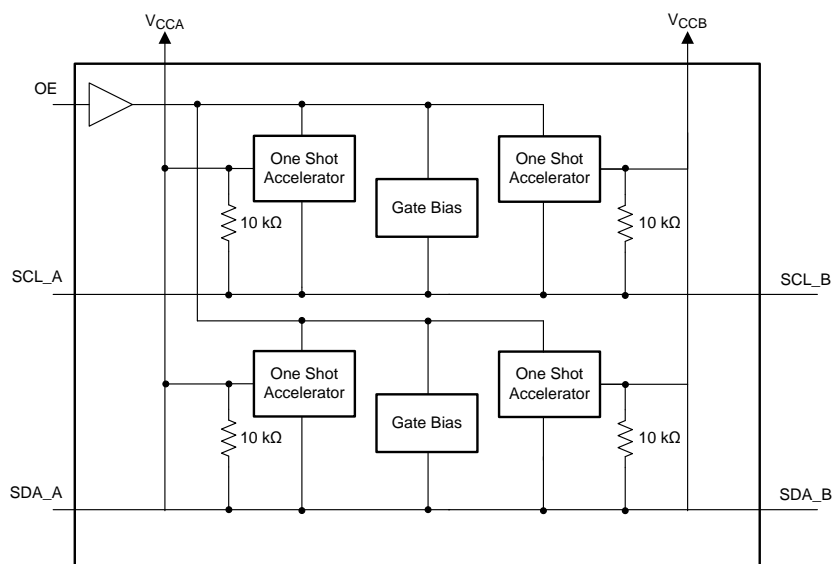

### 8.3 Feature Description

#### 8.3.1 Architecture

The TCA9406 architecture (see Figure 5) is an auto-direction-sensing based translator that does not require a direction-control signal to control the direction of data flow from A to B or from B to A.

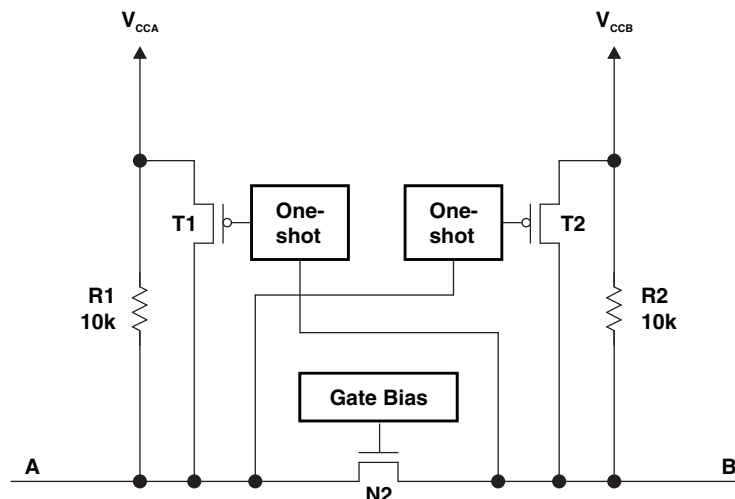

Figure 5. Architecture of a TCA9406 Cell

## Feature Description (continued)

These two bidirectional channels independently determine the direction of data flow without a direction-control signal. Each I/O pin is automatically reconfigured as either an input or an output, which is how this auto-direction feature is realized.

The TCA9406 is part of TI's "Switch" type voltage translator family and employs two key circuits to enable this voltage translation:

- 1) An N-channel pass-gate transistor topology that ties the A-port to the B-port  
and
- 2) Output one-shot (O.S.) edge-rate accelerator circuitry to detect and accelerate rising edges on the A or B ports

For bidirectional voltage translation, pullup resistors are included on the device for dc current sourcing capability. The  $V_{GATE}$  gate bias of the N-channel pass transistor is set at approximately one threshold voltage ( $V_T$ ) above the  $V_{CC}$  level of the low-voltage side. Data can flow in either direction without guidance from a control signal.

The O.S. rising-edge rate accelerator circuitry speeds up the output slew rate by monitoring the input edge for transitions, helping maintain the data rate through the device. During a low-to-high signal rising edge, the O.S. circuits turn on the PMOS transistors (T1, T2) to increase the current drive capability of the driver for approximately 30 ns or 95% of the input edge, whichever occurs first. This edge-rate acceleration provides high ac drive by bypassing the internal 10-k $\Omega$  pullup resistors during the low-to-high transition to speed up the signal. The output resistance of the driver is decreased to approximately 50  $\Omega$  to 70  $\Omega$  during this acceleration phase. To minimize dynamic  $I_{CC}$  and the possibility of signal contention, the user should wait for the O.S. circuit to turn off before applying a signal in the opposite direction. The worst-case duration is equal to the minimum pulse-width number provided in the [Timing Requirements](#) section of this data sheet.

### 8.3.2 Input Driver Requirements

The continuous dc-current "sinking" capability is determined by the external system-level open-drain (or push-pull) drivers that are interfaced to the TCA9406 I/O pins. Since the high bandwidth of these bidirectional I/O circuits is used to facilitate this fast change from an input to an output and an output to an input, they have a modest dc-current "sourcing" capability of hundreds of micro-Amps, as determined by the internal 10-k $\Omega$  pullup resistors.

The fall time ( $t_{fA}$ ,  $t_{fB}$ ) of a signal depends on the edge-rate and output impedance of the external device driving TCA9406 data I/Os, as well as the capacitive loading on the data lines.

Similarly, the  $t_{pHL}$  and max data rates also depend on the output impedance of the external driver. The values for  $t_{fA}$ ,  $t_{fB}$ ,  $t_{pHL}$ , and maximum data rates in the data sheet assume that the output impedance of the external driver is less than 50  $\Omega$ .

### 8.3.3 Output Load Considerations

TI recommends careful PCB layout practices with short PCB trace lengths to avoid excessive capacitive loading and to ensure that proper O.S. triggering takes place. PCB signal trace-lengths should be kept short enough such that the round trip delay of any reflection is less than the one-shot duration. This improves signal integrity by ensuring that any reflection sees a low impedance at the driver. The O.S. circuits have been designed to stay on for approximately 30 ns. The maximum capacitance of the lumped load that can be driven also depends directly on the one-shot duration. With very heavy capacitive loads, the one-shot can time-out before the signal is driven fully to the positive rail. The O.S. duration has been set to best optimize trade-offs between dynamic ICC, load driving capability, and maximum bit-rate considerations. Both PCB trace length and connectors add to the capacitance that the TCA9406 output sees, so it is recommended that this lumped-load capacitance be considered to avoid O.S. re-triggering, bus contention, output signal oscillations, or other adverse system-level affects.

### 8.3.4 Enable and Disable

The TCA9406 has an OE input that is used to disable the device by setting OE low, which places all I/Os in the Hi-Z state. The disable time ( $t_{dis}$ ) indicates the delay between the time when OE goes low and when the outputs are disabled (Hi-Z). The enable time ( $t_{en}$ ) indicates the amount of time the user must allow for the one-shot circuitry to become operational after OE is taken high.

## Feature Description (continued)

### 8.3.5 Pullup or Pulldown Resistors on I/O Lines

Each A-port I/O has an internal 10-k $\Omega$  pullup resistor to  $V_{CCA}$ , and each B-port I/O has an internal 10-k $\Omega$  pullup resistor to  $V_{CCB}$ . If a smaller value of pullup resistor is required, an external resistor must be added from the I/O to  $V_{CCA}$  or  $V_{CCB}$  (in parallel with the internal 10-k $\Omega$  resistors). Adding lower value pullup resistors will effect  $V_{OL}$  levels, however. The internal pullups of the TCA9406 are disabled when the OE pin is low.

### 8.4 Device Functional Modes

The TCA9406 device has two functional modes, enabled and disabled. To disable the device set the OE input low, which places all I/Os in a high impedance state. Setting the OE input high will enable the device.

## 9 Application and Implementation

### NOTE

Information in the following applications sections is not part of the TI component specification, and TI does not warrant its accuracy or completeness. TI's customers are responsible for determining suitability of components for their purposes. Customers should validate and test their design implementation to confirm system functionality.

### 9.1 Application Information

The TCA9406 can be used to bridge the digital-switching compatibility gap between two voltage nodes to successfully interface logic threshold levels found in electronic systems. It should be used in a point-to-point topology for interfacing devices or systems operating at different interface voltages with one another. Its primary target application use is for interfacing with open-drain drivers on the data I/Os such as I<sup>2</sup>C or SMBus, where the data is bidirectional and no control signal is available.

### 9.2 Typical Application

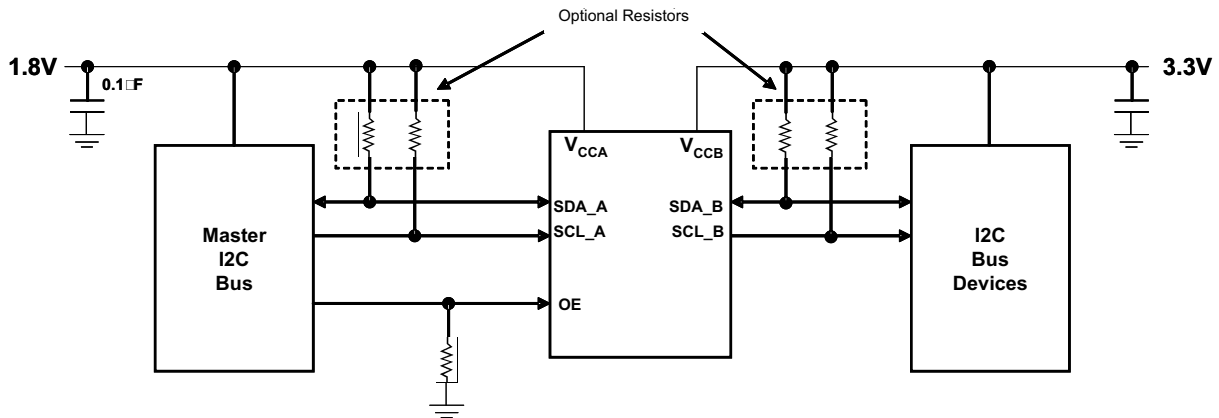

**Design Notes:**  
OE can be tied directly to 1.8V ( $V_{CCA}$ ) to always be in ENABLE mode.

**Figure 6. Typical Application Circuit**

#### 9.2.1 Design Requirements

For this design example, use the parameters listed in [Table 1](#). And make sure the  $V_{CCA} \leq V_{CCB}$ .

**Table 1. Design Parameters**

DESIGN PARAMETER	EXAMPLE VALUE
Input voltage range	1.65 to 3.6 V
Output voltage range	2.3 to 5.5 V

#### 9.2.2 Detailed Design Procedure

To begin the design process, determine the following:

- Input voltage range
  - Use the supply voltage of the device that is driving the TCA9406 device to determine the input voltage range. For a valid logic high the value must exceed the  $V_{IH}$  of the input port. For a valid logic low the value must be less than the  $V_{IL}$  of the input port.
- Output voltage range
  - Use the supply voltage of the device that the TCA9406 device is driving to determine the output voltage range.

- The TCA9406 device has 10-k $\Omega$  internal pullup resistors. External pullup resistors can be added to reduce the total RC of a signal trace if necessary.
- An external pull down resistor decreases the output  $V_{OH}$  and  $V_{OL}$ . Use the following equation to calculate the  $V_{OH}$  as a result of an external pull down resistor.

$$V_{OH} = V_{CCx} \times R_{PD} / (R_{PD} + 10 \text{ k}\Omega)$$

Where:

- $V_{CCx}$  is the supply voltage on either  $V_{CCA}$  or  $V_{CCB}$
- $R_{PD}$  is the value of the external pull down resistor

### 9.2.3 Application Curve

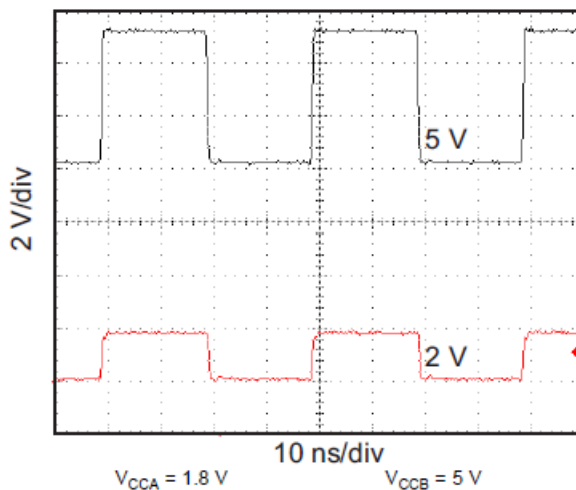

Figure 7. Level-Translation of a 2.5-MHz Signal

## 10 Power Supply Recommendations

During operation, ensure that  $V_{CCA} \leq V_{CCB}$  at all times. The sequencing of each power supply will not damage the device during the power up operation, so either power supply can be ramped up first. The output-enable (OE) input circuit is designed so that it is supplied by  $V_{CCA}$  and when the (OE) input is low, all outputs are placed in the high-impedance state. To ensure the high-impedance state of the outputs during power up or power down, the OE input pin must be tied to GND through a pull-down resistor and must not be enabled until  $V_{CCA}$  and  $V_{CCB}$  are fully ramped and stable. The minimum value of the pull-down resistor to ground is determined by the current-sourcing capability of the driver.

## 11 Layout

### 11.1 Layout Guidelines

To ensure reliability of the device, the following common printed-circuit board layout guidelines are recommended:

- Bypass capacitors should be used on power supplies and should be placed as close as possible to the  $V_{CCA}$ ,  $V_{CCB}$  pin, and  $G_{ND}$  pin.
- Short trace lengths should be used to avoid excessive loading.
- PCB signal trace-lengths must be kept short enough so that the round-trip delay of any reflection is less than the one-shot duration, approximately 30 ns, ensuring that any reflection encounters low impedance at the source driver.

### 11.2 Layout Example

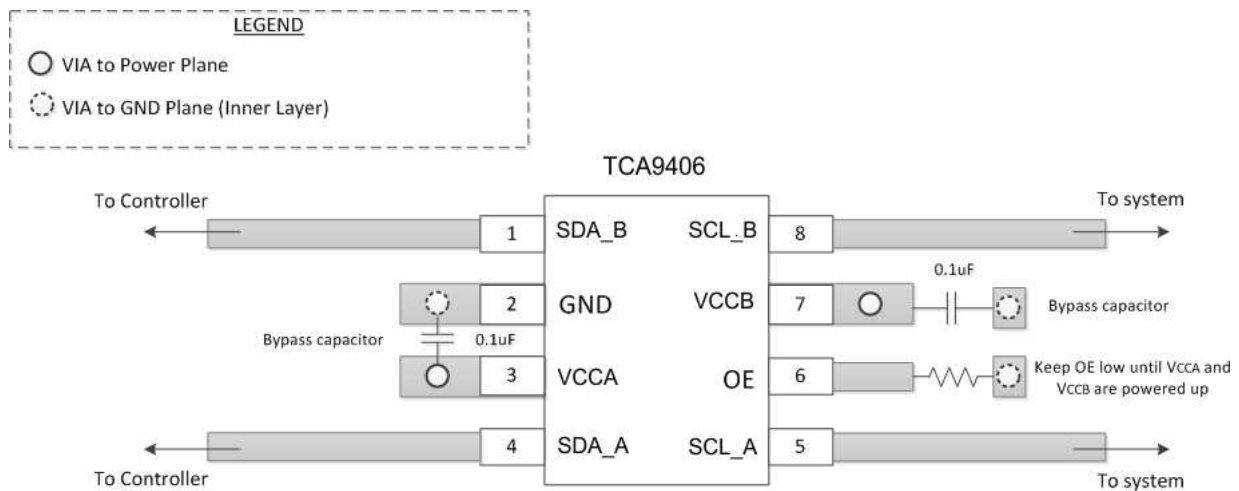

Figure 8. TCA9406 Layout Example

## 12 Device and Documentation Support

### 12.1 Trademarks

All trademarks are the property of their respective owners.

### 12.2 Electrostatic Discharge Caution



These devices have limited built-in ESD protection. The leads should be shorted together or the device placed in conductive foam during storage or handling to prevent electrostatic damage to the MOS gates.

### 12.3 Glossary

[SLYZ022](#) — *TI Glossary*.

This glossary lists and explains terms, acronyms, and definitions.

## 13 Mechanical, Packaging, and Orderable Information

The following pages include mechanical, packaging, and orderable information. This information is the most current data available for the designated devices. This data is subject to change without notice and revision of this document. For browser-based versions of this data sheet, refer to the left-hand navigation.

## PACKAGING INFORMATION

Orderable Device	Status (1)	Package Type	Package Drawing	Pins	Package Qty	Eco Plan (2)	Lead/Ball Finish (6)	MSL Peak Temp (3)	Op Temp (°C)	Device Marking (4/5)	Samples
TCA9406DCTR	ACTIVE	SM8	DCT	8	3000	Green (RoHS & no Sb/Br)	CU NIPDAU	Level-1-260C-UNLIM	-40 to 85	NF9 Z	<a href="#">Samples</a>
TCA9406DCUR	ACTIVE	VSSOP	DCU	8	3000	Green (RoHS & no Sb/Br)	CU NIPDAU   CU SN	Level-1-260C-UNLIM	-40 to 85	(F9 ~ NF9R) NZ	<a href="#">Samples</a>
TCA9406YZPR	ACTIVE	DSBGA	YZP	8	3000	Green (RoHS & no Sb/Br)	SNAGCU	Level-1-260C-UNLIM	-40 to 85	7W	<a href="#">Samples</a>

(1) The marketing status values are defined as follows:

**ACTIVE:** Product device recommended for new designs.

**LIFEBUY:** TI has announced that the device will be discontinued, and a lifetime-buy period is in effect.

**NRND:** Not recommended for new designs. Device is in production to support existing customers, but TI does not recommend using this part in a new design.

**PREVIEW:** Device has been announced but is not in production. Samples may or may not be available.

**OBSOLETE:** TI has discontinued the production of the device.

(2) Eco Plan - The planned eco-friendly classification: Pb-Free (RoHS), Pb-Free (RoHS Exempt), or Green (RoHS & no Sb/Br) - please check <http://www.ti.com/productcontent> for the latest availability information and additional product content details.

**TBD:** The Pb-Free/Green conversion plan has not been defined.

**Pb-Free (RoHS):** TI's terms "Lead-Free" or "Pb-Free" mean semiconductor products that are compatible with the current RoHS requirements for all 6 substances, including the requirement that lead not exceed 0.1% by weight in homogeneous materials. Where designed to be soldered at high temperatures, TI Pb-Free products are suitable for use in specified lead-free processes.

**Pb-Free (RoHS Exempt):** This component has a RoHS exemption for either 1) lead-based flip-chip solder bumps used between the die and package, or 2) lead-based die adhesive used between the die and leadframe. The component is otherwise considered Pb-Free (RoHS compatible) as defined above.

**Green (RoHS & no Sb/Br):** TI defines "Green" to mean Pb-Free (RoHS compatible), and free of Bromine (Br) and Antimony (Sb) based flame retardants (Br or Sb do not exceed 0.1% by weight in homogeneous material)

(3) MSL, Peak Temp. - The Moisture Sensitivity Level rating according to the JEDEC industry standard classifications, and peak solder temperature.

(4) There may be additional marking, which relates to the logo, the lot trace code information, or the environmental category on the device.

(5) Multiple Device Markings will be inside parentheses. Only one Device Marking contained in parentheses and separated by a "~" will appear on a device. If a line is indented then it is a continuation of the previous line and the two combined represent the entire Device Marking for that device.

(6) Lead/Ball Finish - Orderable Devices may have multiple material finish options. Finish options are separated by a vertical ruled line. Lead/Ball Finish values may wrap to two lines if the finish value exceeds the maximum column width.

**Important Information and Disclaimer:** The information provided on this page represents TI's knowledge and belief as of the date that it is provided. TI bases its knowledge and belief on information provided by third parties, and makes no representation or warranty as to the accuracy of such information. Efforts are underway to better integrate information from third parties. TI has taken and

# PACKAGE OPTION ADDENDUM

17-Aug-2015

---

continues to take reasonable steps to provide representative and accurate information but may not have conducted destructive testing or chemical analysis on incoming materials and chemicals. TI and TI suppliers consider certain information to be proprietary, and thus CAS numbers and other limited information may not be available for release.

In no event shall TI's liability arising out of such information exceed the total purchase price of the TI part(s) at issue in this document sold by TI to Customer on an annual basis.

## TAPE AND REEL INFORMATION

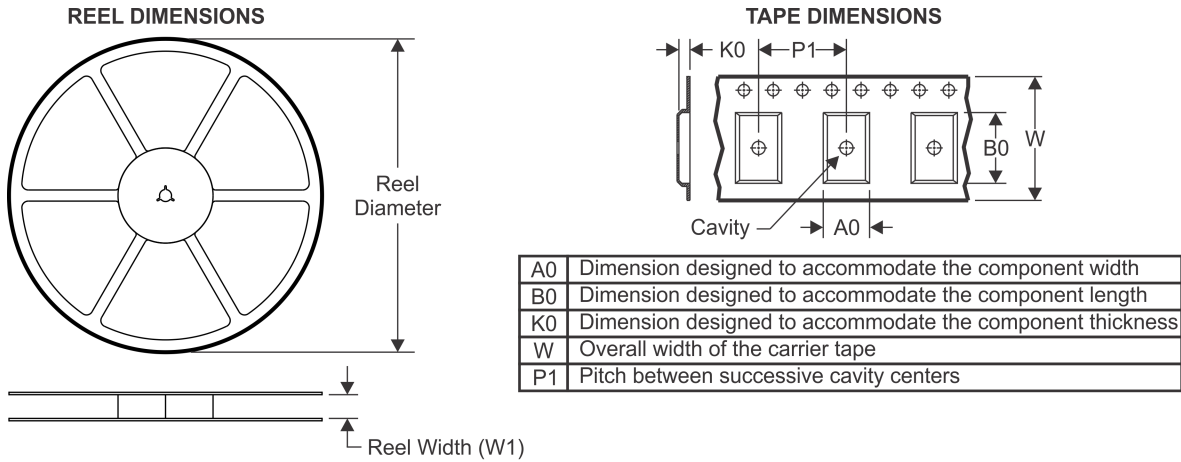

### QUADRANT ASSIGNMENTS FOR PIN 1 ORIENTATION IN TAPE

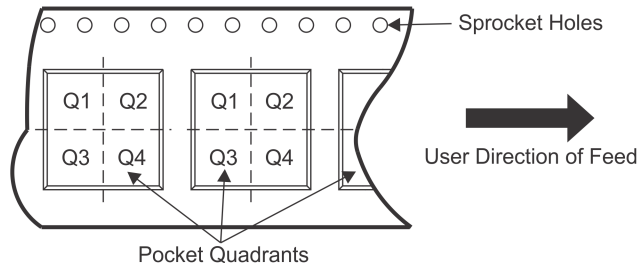

\*All dimensions are nominal

Device	Package Type	Package Drawing	Pins	SPQ	Reel Diameter (mm)	Reel Width W1 (mm)	A0 (mm)	B0 (mm)	K0 (mm)	P1 (mm)	W (mm)	Pin1 Quadrant
TCA9406DCTR	SM8	DCT	8	3000	180.0	13.0	3.35	4.5	1.55	4.0	12.0	Q3
TCA9406DCUR	VSSOP	DCU	8	3000	180.0	8.4	2.25	3.35	1.05	4.0	8.0	Q3
TCA9406YZPR	DSBGA	YZP	8	3000	180.0	8.4	1.11	2.1	0.56	4.0	8.0	Q1

## TAPE AND REEL BOX DIMENSIONS

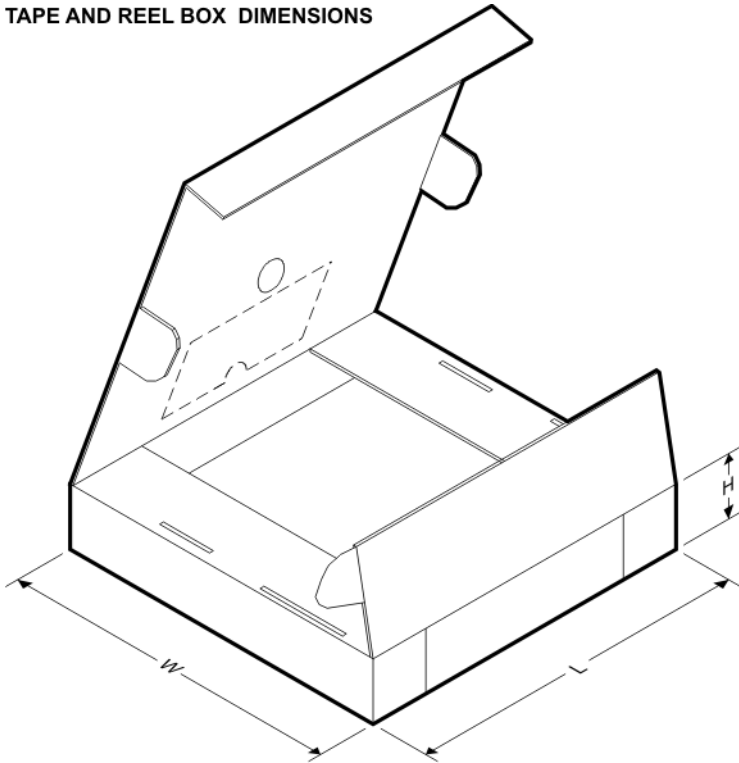

\*All dimensions are nominal

Device	Package Type	Package Drawing	Pins	SPQ	Length (mm)	Width (mm)	Height (mm)
TCA9406DCTR	SM8	DCT	8	3000	182.0	182.0	20.0
TCA9406DCUR	VSSOP	DCU	8	3000	202.0	201.0	28.0
TCA9406YZPR	DSBGA	YZP	8	3000	182.0	182.0	20.0

DCT (R-PDSO-G8)

PLASTIC SMALL-OUTLINE PACKAGE

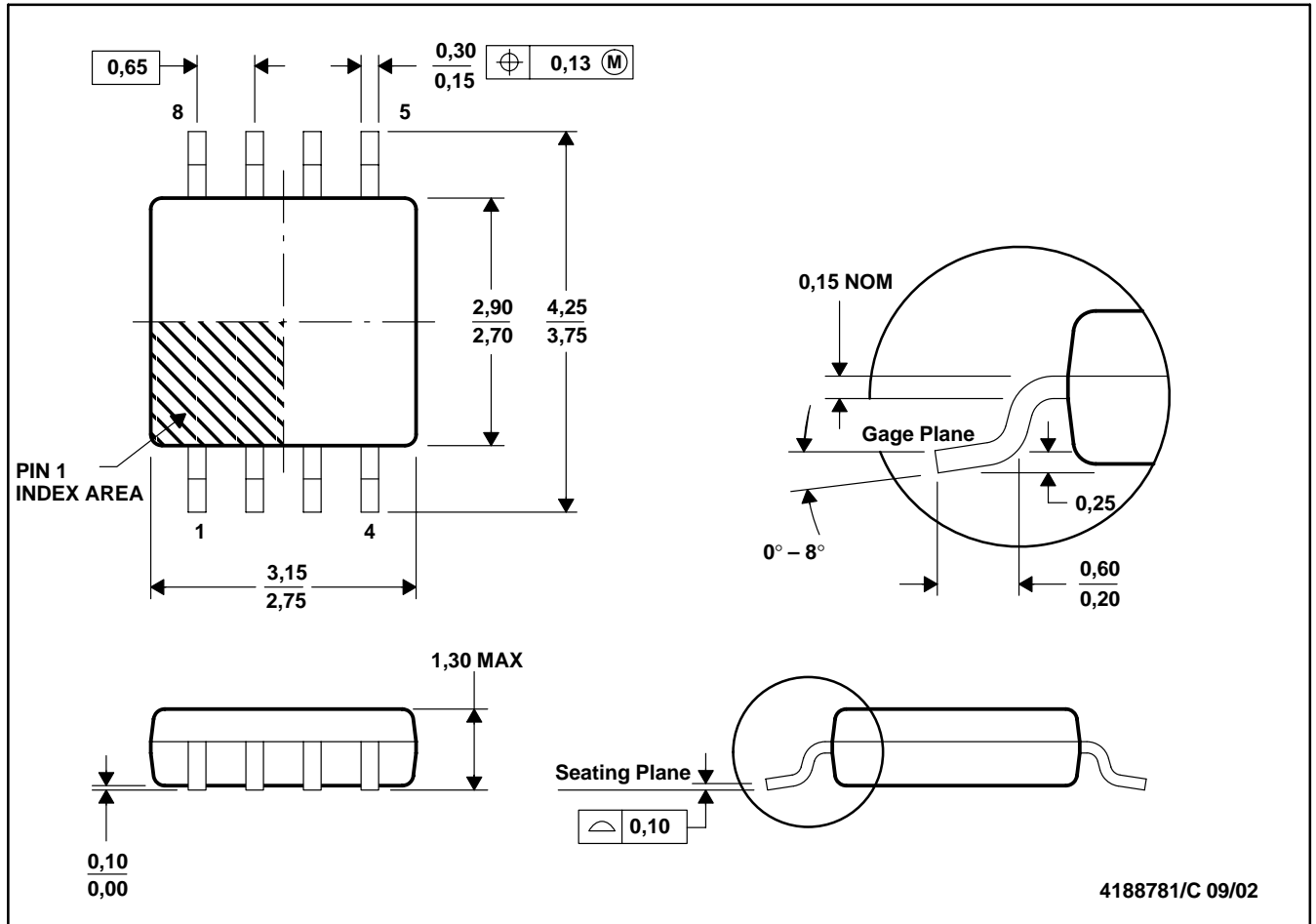

4188781/C 09/02

- NOTES:
- A. All linear dimensions are in millimeters.
  - B. This drawing is subject to change without notice.
  - C. Body dimensions do not include mold flash or protrusion.
  - D. Falls within JEDEC MO-187 variation DA.

DCT (R-PDSO-G8)

PLASTIC SMALL OUTLINE

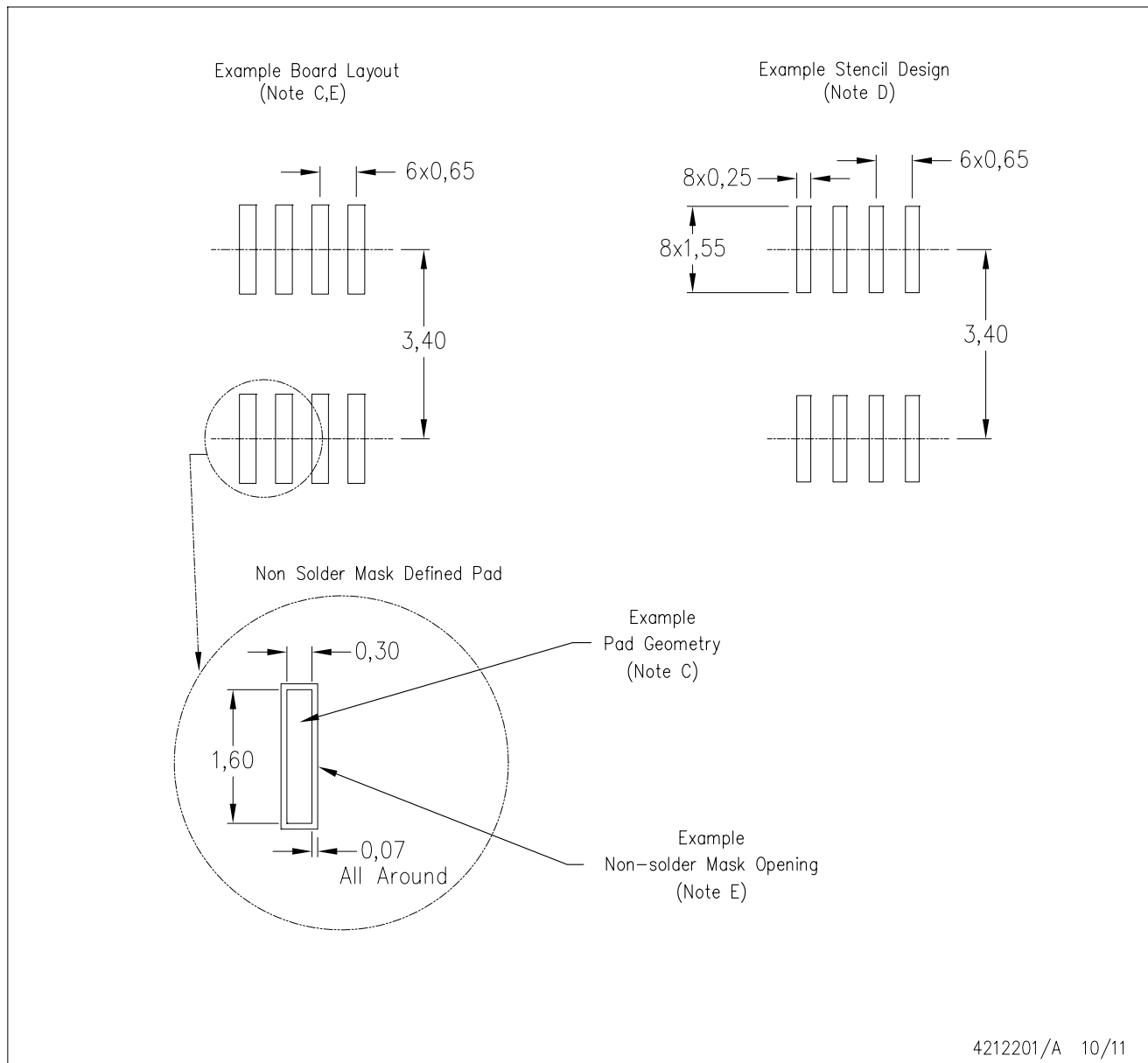

- NOTES:
- A. All linear dimensions are in millimeters.
  - B. This drawing is subject to change without notice.
  - C. Publication IPC-7351 is recommended for alternate designs.
  - D. Laser cutting apertures with trapezoidal walls and also rounding corners will offer better paste release. Customers should contact their board assembly site for stencil design recommendations. Refer to IPC-7525.
  - E. Customers should contact their board fabrication site for solder mask tolerances between and around signal pads.



DCU (S-PDSO-G8)

PLASTIC SMALL OUTLINE PACKAGE (DIE DOWN)

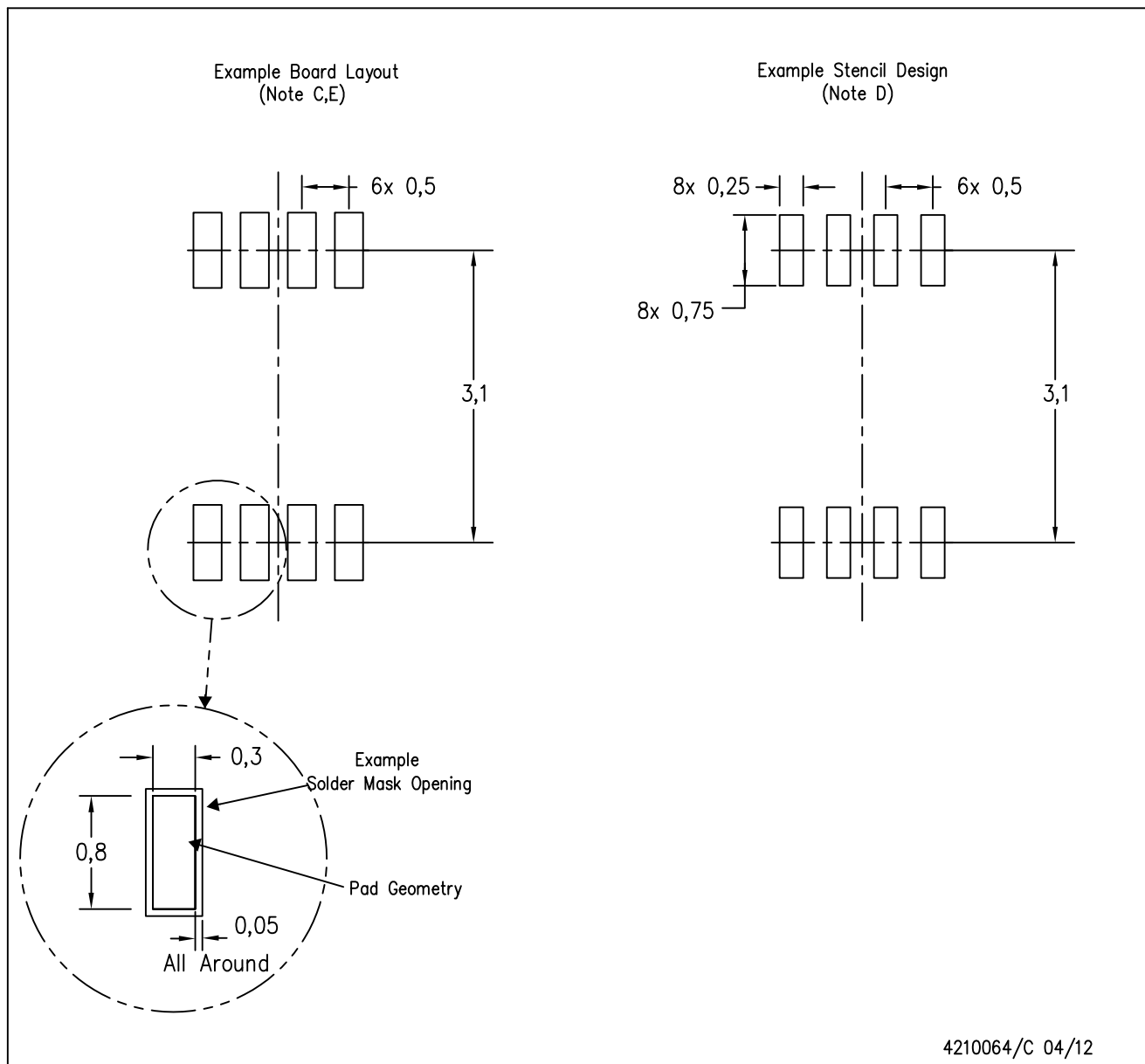

- NOTES:
- A. All linear dimensions are in millimeters.
  - B. This drawing is subject to change without notice.
  - C. Publication IPC-7351 is recommended for alternate designs.
  - D. Laser cutting apertures with trapezoidal walls and also rounding corners will offer better paste release. Customers should contact their board assembly site for stencil design recommendations. Refer to IPC-7525 for other stencil recommendations.
  - E. Customers should contact their board fabrication site for solder mask tolerances between and around signal pads.

YZP (R-XBGA-N8)

DIE-SIZE BALL GRID ARRAY

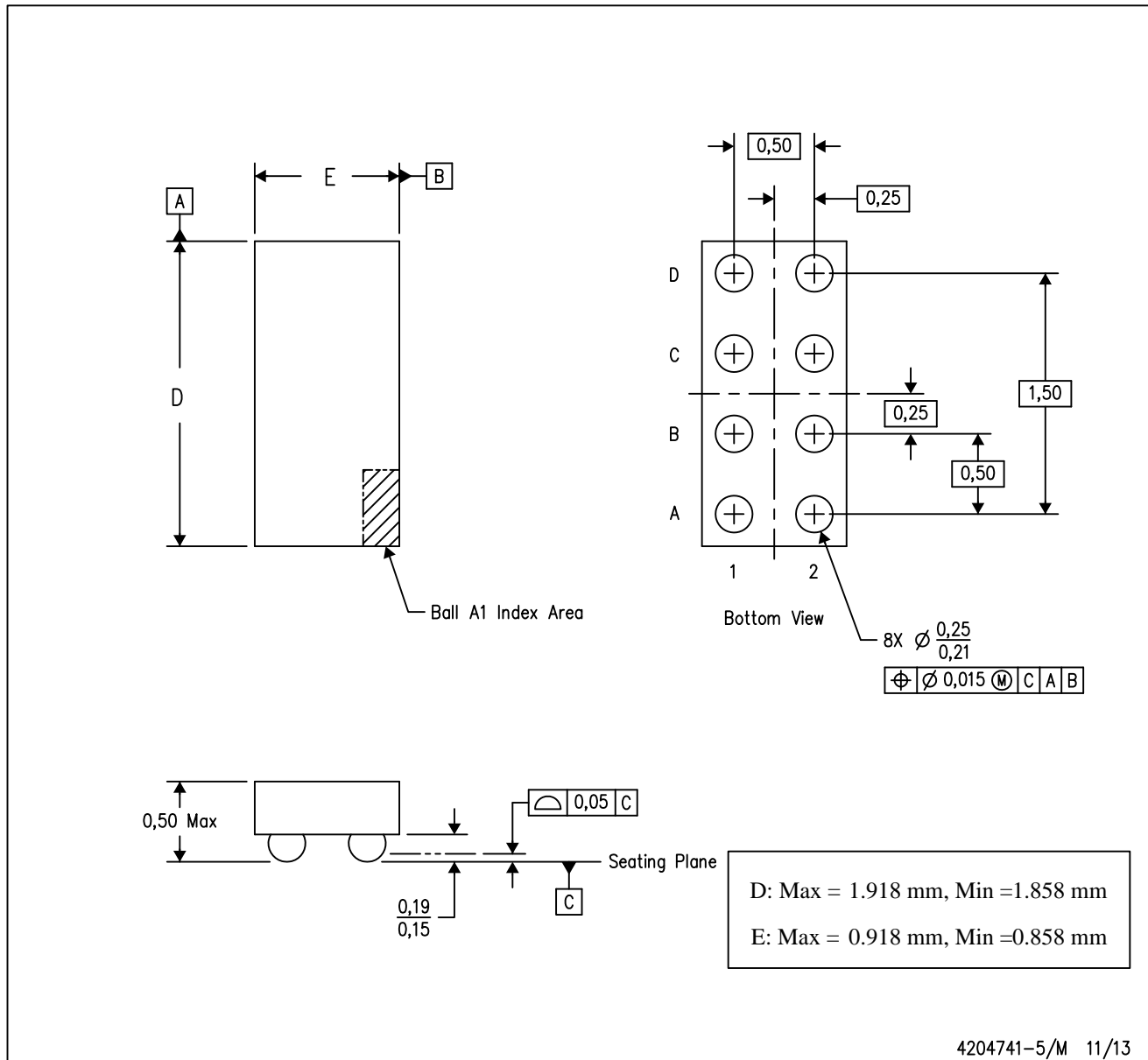

- NOTES:
- A. All linear dimensions are in millimeters. Dimensioning and tolerancing per ASME Y14.5M-1994.
  - B. This drawing is subject to change without notice.
  - C. NanoFree™ package configuration.