

WIDEBAND, LOW-NOISE, LOW-DISTORTION, FULLY-DIFFERENTIAL AMPLIFIER

Check for Samples: [THS4511](#)

FEATURES

- Fully-Differential Architecture
- Common-Mode Input Range Includes the Negative Rail
- Unity-Gain Stable
- Bandwidth: 1.6 GHz (Gain = 0 dB)
- Slew Rate: 4900 V/ μ s
- 1% Settling Time: 3.3 ns
- HD₂: –72 dBc at 70 MHz
- HD₃: –87 dBc at 70 MHz
- OIP₂: 76 dBm at 70 MHz
- OIP₃: 42 dBm at 70 MHz
- Input Voltage Noise: 2 nV/ $\sqrt{\text{Hz}}$ ($f > 10$ MHz)
- Noise Figure: 21.8 dB (50- Ω System, G = 6 dB)
- Output Common-Mode Control
- 5-V Power-Supply Current: 39.2 mA
- Power-Down Capability: 0.65 mA

APPLICATIONS

- 5-V Data-Acquisition Systems
- High Linearity ADC Amplifiers
- Wireless Communication
- Medical Imaging
- Test and Measurement

RELATED PRODUCTS

DEVICE	MIN. GAIN	COMMON-MODE RANGE OF INPUT ⁽¹⁾
THS4508	6 dB	–0.3 V to 2.3 V
THS4509	6 dB	0.75 V to 4.25 V
THS4511	0 dB	–0.3 V to 2.3 V
THS4513	0 dB	0.75 V to 4.25 V

1. Assumes a 5-V single-ended power supply.

DESCRIPTION

The THS4511 is a wideband, fully-differential operational amplifier designed for single-supply 5-V data-acquisition systems. It has very low noise at 2 nV/ $\sqrt{\text{Hz}}$, and extremely low harmonic distortion of –72 dBc HD₂ and –87 dBc HD₃ at 70 MHz with 2 V_{PP}, G = 0 dB, and 200- Ω load. Slew rate is very high at 4900 V/ μ s and with settling time of 3.3 ns to 1% (2 V step) it is ideal for pulsed applications. It is designed for minimum gain of 0 dB.

To allow for dc coupling to analog-to-digital converters (ADCs), its unique output common-mode control circuit maintains the output common-mode voltage within 5-mV offset (typical) from the set voltage, when set within ± 0.5 V of midsupply. The common-mode set point is set to midsupply by internal circuitry, which may be over-driven from an external source.

The THS4511 is a high-performance amplifier that has been optimized for use in 5-V single-supply data acquisition systems. The output has been optimized for best performance with its common-mode voltages set to midsupply, and the input has been optimized for performance over a wide range of common-mode input voltages. High performance at a low power-supply voltage enables single-supply 5-V data-acquisition systems while minimizing component count.

The THS4511 is offered in a quad, 16-pin leadless QFN package (RGT), and is characterized for operation over the full industrial temperature range from –40°C to +85°C.

Video Buffer, Single-Ended to Differential

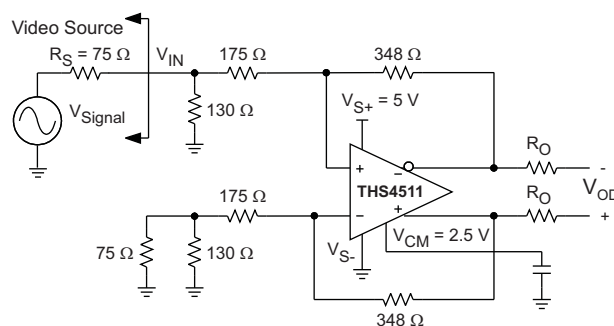

Please be aware that an important notice concerning availability, standard warranty, and use in critical applications of Texas Instruments semiconductor products and disclaimers thereto appears at the end of this data sheet.

PowerPAD is a trademark of Texas Instruments Incorporated.



This integrated circuit can be damaged by ESD. Texas Instruments recommends that all integrated circuits be handled with appropriate precautions. Failure to observe proper handling and installation procedures can cause damage.

ESD damage can range from subtle performance degradation to complete device failure. Precision integrated circuits may be more susceptible to damage because very small parametric changes could cause the device not to meet its published specifications.

ABSOLUTE MAXIMUM RATINGS⁽¹⁾

Over operating free-air temperature range, unless otherwise noted.

			UNIT
V _{SS}	Supply voltage	V _{S-} to V _{S+}	5.5 V
V _I	Input voltage		±V _S
V _{ID}	Differential input voltage		4 V
I _O	Output current		200 mA
Continuous power dissipation			See Dissipation Ratings Table
T _J	Maximum junction temperature ⁽²⁾		+150°C
T _J	Maximum junction temperature, continuous operation, long term reliability ⁽³⁾		+125°C
T _A	Operating free-air temperature range		–40°C to +85°C
T _{STG}	Storage temperature range		–65°C to +150°C
ESD ratings	HBM		2000 V
	CDM		1500 V
	MM		100 V

- (1) Stresses above these ratings may cause permanent damage. Exposure to absolute maximum conditions for extended periods may degrade device reliability. These are stress ratings only, and functional operation of the device at these or any other conditions beyond those specified is not implied.
- (2) The absolute maximum temperature under any condition is limited by the constraints of the silicon process.
- (3) The maximum junction temperature for continuous operation is limited by the package constraints. Operation above this temperature may result in reduced reliability and/or lifetime of the device. The THS4511 incorporates a (QFN) exposed thermal pad on the underside of the chip. This acts as a heatsink and must be connected to a thermally-dissipative plane for proper power dissipation. Failure to do so may result in exceeding the maximum junction temperature which could permanently damage the device. See TI technical brief [SLMA002](#) and [SLMA004](#) for more information about using the QFN thermally-enhanced package.

DISSIPATION RATINGS TABLE

PACKAGE ⁽¹⁾	θ _{JC}	θ _{JA}	POWER RATING	
			T _A ≤ +25°C	T _A = +85°C
RGT (16)	2.4°C/W	39.5°C/W	2.3 W	225 mW

- (1) For the most current package and ordering information, see the Package Option Addendum at the end of this document, or see the TI web site at www.ti.com.

DEVICE INFORMATION

**RGT PACKAGE
16-PIN LEADLESS QFN
(TOP VIEW)**

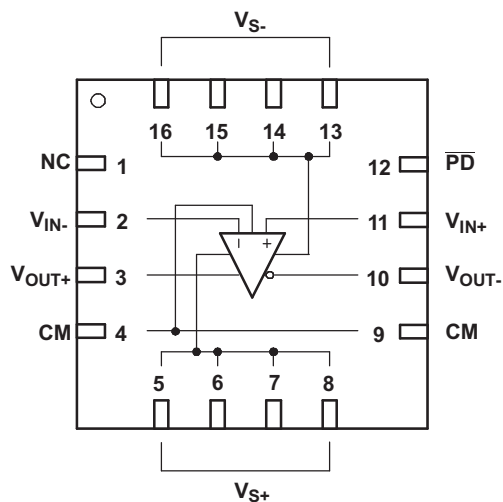

TERMINAL FUNCTIONS

TERMINAL (RGT PACKAGE)		DESCRIPTION
NO.	NAME	
1	NC	No internal connection
2	V_{IN-}	Inverting amplifier input
3	V_{OUT+}	Noninverting amplifier output
4, 9	CM	Common-mode voltage input
5-8	V_{S+}	Positive amplifier power supply input
10	V_{OUT-}	Inverted amplifier output
11	V_{IN+}	Noninverting amplifier input
12	\overline{PD}	Power-down; \overline{PD} = logic low puts part into low power mode, \overline{PD} = logic high or open for normal operation
13-16	V_{S-}	Negative amplifier power-supply input

ELECTRICAL CHARACTERISTICS: $V_{S+} - V_{S-} = 5\text{ V}$

Test conditions unless otherwise noted: $V_{S+} = 5\text{ V}$, $V_{S-} = 0\text{ V}$, $G = 0\text{ dB}$, $CM = \text{open}$, $V_O = 2\text{ V}_{PP}$, $R_F = 349\ \Omega$, $R_L = 200\ \Omega$ differential, $T = +25^\circ\text{C}$ single-ended input, differential output, input referenced to ground, and output referenced to midsupply.

PARAMETER	TEST CONDITIONS		THS4511			UNITS	TEST LEVEL ⁽¹⁾
			MIN	TYP	MAX		
AC PERFORMANCE (see Figure 38)							
Small-Signal Bandwidth	$G = 0\text{ dB}$, $V_O = 100\text{ mV}_{PP}$			1.6		GHz	C
	$G = 6\text{ dB}$, $V_O = 100\text{ mV}_{PP}$			1.4			
Gain-Bandwidth Product				2		GHz	
Bandwidth for 0.1-dB flatness	$G = 0\text{ dB}$, $V_O = 2\text{ V}_{PP}$			160		MHz	
	$G = 6\text{ dB}$, $V_O = 2\text{ V}_{PP}$			620			
Large-Signal Bandwidth	$G = 10\text{ dB}$, $V_O = 2\text{ V}_{PP}$			1.35		GHz	
Slew Rate (Differential)				4900		V/ μs	
Rise Time	$V_O = 2\text{-V Step}$			0.5		ns	
Fall Time				0.5		ns	
Settling Time to 1%				3.3		ns	
Settling Time to 0.1%				16		ns	
2 nd Order Harmonic Distortion	$f = 10\text{ MHz}$			-117		dBc	
	$f = 50\text{ MHz}$			-80			
	$f = 100\text{ MHz}$			-64			
3 rd Order Harmonic Distortion	$f = 10\text{ MHz}$			-106		dBc	
	$f = 50\text{ MHz}$			-92			
	$f = 100\text{ MHz}$			-80			
2 nd Order Intermodulation Distortion	200-kHz tone spacing, $R_L = 100\ \Omega$	$f_C = 70\text{ MHz}$		-78		dBc	
		$f_C = 140\text{ MHz}$		-56			
3 rd Order Intermodulation Distortion		$f_C = 70\text{ MHz}$		-88		dBc	
		$f_C = 140\text{ MHz}$		-71.4			
2 nd Order Output Intercept Point	200-kHz tone spacing, $R_L = 100\ \Omega$	$f_C = 70\text{ MHz}$		76.3		dBm	
		$f_C = 140\text{ MHz}$		53.4			
3 rd Order Output Intercept Point		$f_C = 70\text{ MHz}$		42		dBm	
		$f_C = 140\text{ MHz}$		34			
1-dB Compression Point ⁽²⁾	$f_C = 70\text{ MHz}$			12.2		dBm	
	$f_C = 140\text{ MHz}$			10.8			
Noise Figure	50- Ω system, 10 MHz			21.8		dB	
Input Voltage Noise	$f > 10\text{ MHz}$			2		nV/ $\sqrt{\text{Hz}}$	
Input Current Noise	$f > 10\text{ MHz}$			1.5		pA/ $\sqrt{\text{Hz}}$	
DC PERFORMANCE							
Open-Loop Voltage Gain (A_{OL})				63		dB	C
Input Offset Voltage	$T_A = +25^\circ\text{C}$			1	4	mV	A
	$T_A = -40^\circ\text{C to } +85^\circ\text{C}$			1	5		
Average Offset Voltage Drift				2.3		$\mu\text{V}/^\circ\text{C}$	B
Input Bias Current	$T_A = +25^\circ\text{C}$		1.75	8	15.5	μA	A
	$T_A = -40^\circ\text{C to } +85^\circ\text{C}$			8	18.5		
Average Bias Current Drift				20		nA/ $^\circ\text{C}$	B
Input Offset Current	$T_A = +25^\circ\text{C}$			0.5	3.6	μA	A
	$T_A = -40^\circ\text{C to } +85^\circ\text{C}$			0.5	7		
Average Offset Current Drift				7		nA/ $^\circ\text{C}$	B

- (1) Test levels: (A) 100% tested at +25°C. Over-temperature limits by characterization and simulation. (B) Limits set by characterization and simulation. (C) Typical value only for information.
- (2) The 1-dB compression point is measured at the load with 50- Ω double termination. Add 3 dB to refer to amplifier output.

ELECTRICAL CHARACTERISTICS: $V_{S+} - V_{S-} = 5\text{ V}$ (continued)

Test conditions unless otherwise noted: $V_{S+} = 5\text{ V}$, $V_{S-} = 0\text{ V}$, $G = 0\text{ dB}$, $CM = \text{open}$, $V_O = 2\text{ V}_{PP}$, $R_F = 349\ \Omega$, $R_L = 200\ \Omega$ differential, $T = +25^\circ\text{C}$ single-ended input, differential output, input referenced to ground, and output referenced to midsupply.

PARAMETER	TEST CONDITIONS	THS4511			UNITS	TEST LEVEL ⁽¹⁾	
		MIN	TYP	MAX			
INPUT							
Common-Mode Input Range High			2.3		V	B	
Common-Mode Input Range Low			-0.3				
Common-Mode Rejection Ratio			90		dB		
Differential Input Impedance			18.2 1.62		M Ω pF	C	
Common-Mode Input Impedance			4.0 1.73				
OUTPUT							
Maximum Output Voltage High	Each output with 100 Ω to midsupply	$T_A = +25^\circ\text{C}$	3.7	3.8	V	A	
		$T_A = -40^\circ\text{C}$ to $+85^\circ\text{C}$	3.6	3.8			
Minimum Output Voltage Low		$T_A = +25^\circ\text{C}$		1.2			1.3
		$T_A = -40^\circ\text{C}$ to $+85^\circ\text{C}$		1.2			1.4
Differential Output Voltage Swing	$T_A = +25^\circ\text{C}$	4.8	5.2		V	A	
	$T_A = -40^\circ\text{C}$ to $+85^\circ\text{C}$	4.4	5.2				
Differential Output Current Drive	$R_L = 10\ \Omega$		96		mA	C	
Output Balance Error	$V_O = 100\text{ mV}$, $f = 1\text{ MHz}$		-52		dB	C	
Closed-Loop Output Impedance	$f = 1\text{ MHz}$		0.3		Ω	C	
OUTPUT COMMON-MODE VOLTAGE CONTROL							
Small-Signal Bandwidth			250		MHz	C	
Slew Rate			110		V/ μs		
Gain			1		V/V		
Output Common-Mode Offset from CM Input	$1.25\text{ V} < CM < 3.5\text{ V}$		5		mV		
CM Input Bias Current	$1.25\text{ V} < CM < 3.5\text{ V}$		± 40		μA		
CM Input Voltage Range			1.25 to 3.75		V		
CM Input Impedance			32 1.5		k Ω pF		
CM Default Voltage	CM pins floating		2.5		V		
POWER SUPPLY							
Specified Operating Voltage		3.75 ⁽³⁾	5	5.25	V	C	
Maximum Quiescent Current	$T_A = +25^\circ\text{C}$		39.2	42.5	mA	A	
	$T_A = -40^\circ\text{C}$ to $+85^\circ\text{C}$		39.2	43.5			
Minimum Quiescent Current	$T_A = +25^\circ\text{C}$	35.9	39.2		mA	A	
	$T_A = -40^\circ\text{C}$ to $+85^\circ\text{C}$	35	39.2				
Power-Supply Rejection ($\pm\text{PSRR}$)	To differential output		90		dB	C	
POWER-DOWN							
Referenced to V_{S-}							
Enable Voltage Threshold	Device assured <i>on</i> above 2.1 V		> 2.1		V	C	
Disable Voltage Threshold	Device assured <i>off</i> below 0.7 V		< 0.7				
Power-Down Quiescent Current	$T_A = +25^\circ\text{C}$		0.65	0.9	mA	A	
	$T_A = -40^\circ\text{C}$ to $+85^\circ\text{C}$		0.65	1			
Input Bias Current	$\overline{PD} = V_{S-}$		100		μA	C	
Input Impedance			50 2		k Ω pF		
Turn-On Time Delay	Measured to output on		55		ns		
Turn-Off Time Delay	Measured to output off		10		μs		

(3) See the [Application Information](#) section of this data sheet for device operation with full supply voltages less than 5 V.

TYPICAL CHARACTERISTICS

Small-Signal Frequency Response	G = 0 dB, $V_{OD} = 100 \text{ mV}_{PP}$		Figure 1
	G = 6 dB, $V_{OD} = 100 \text{ mV}_{PP}$		Figure 2
Large-Signal Frequency Response	G = 0 dB, $V_{OD} = 2 \text{ V}_{PP}$		Figure 3
	G = 6 dB, $V_{OD} = 2 \text{ V}_{PP}$		Figure 4
Harmonic Distortion	HD ₂ , G = 0 dB, $V_{OD} = 2 \text{ V}_{PP}$	vs Frequency	Figure 5
	HD ₃ , G = 0 dB, $V_{OD} = 2 \text{ V}_{PP}$	vs Frequency	Figure 6
	HD ₂ , G = 6 dB, $V_{OD} = 2 \text{ V}_{PP}$	vs Frequency	Figure 7
	HD ₃ , G = 6 dB, $V_{OD} = 2 \text{ V}_{PP}$	vs Frequency	Figure 8
	HD ₂ , G = 0 dB	vs Output Voltage	Figure 9
	HD ₃ , G = 0 dB	vs Output Voltage	Figure 10
	HD ₂ , G = 0 dB	vs CM Output Voltage	Figure 11
	HD ₃ , G = 0 dB	vs CM Output Voltage	Figure 12
Intermodulation Distortion	IMD ₂ , G = 0 dB	vs Frequency	Figure 13
	IMD ₃ , G = 0 dB	vs Frequency	Figure 14
Output Intercept Point	OIP ₂	vs Frequency	Figure 15
	OIP ₃	vs Frequency	Figure 16
S-Parameters		vs Frequency	Figure 17
Transition Rate		vs Output Voltage	Figure 18
Transient Response			Figure 19
Settling Time			Figure 20
Rejection Ratio		vs Frequency	Figure 21
Output Impedance		vs Frequency	Figure 22
Overdrive Recovery			Figure 23
Differential Output Voltage		Load Resistance	Figure 24
Turn-Off Time			Figure 25
Turn-On Time			Figure 26
Input Offset Voltage		vs Input Common-Mode Voltage	Figure 27
Open-Loop Gain and Phase		vs Frequency	Figure 28
Input-Referred Noise		vs Frequency	Figure 29
Noise Figure		vs Frequency	Figure 30
Quiescent Current		vs Supply Voltage	Figure 31
Output Balance Error		vs Frequency	Figure 32
CM Input Impedance		vs Frequency	Figure 33
CM Small-Signal Frequency Response			Figure 34
CM Input Bias Current		vs CM Input Voltage	Figure 35
Differential Output Offset Voltage		vs CM Input Voltage	Figure 36
Output Common-Mode Offset		vs CM Input Voltage	Figure 37

TYPICAL CHARACTERISTICS: $V_{S+} - V_{S-} = 5\text{ V}$

Test conditions unless otherwise noted: $V_{S+} = 5\text{ V}$, $V_{S-} = 0\text{ V}$, $G = 0\text{ dB}$, $CM = \text{open}$, $V_O = 2\text{ V}_{PP}$, $R_F = 349\ \Omega$, $R_L = 200\ \Omega$ differential, single-ended input, input referenced to ground, and output referenced to midrail.

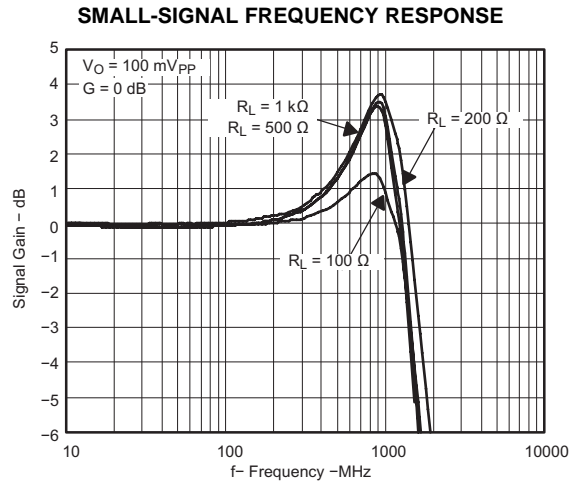

Figure 1.

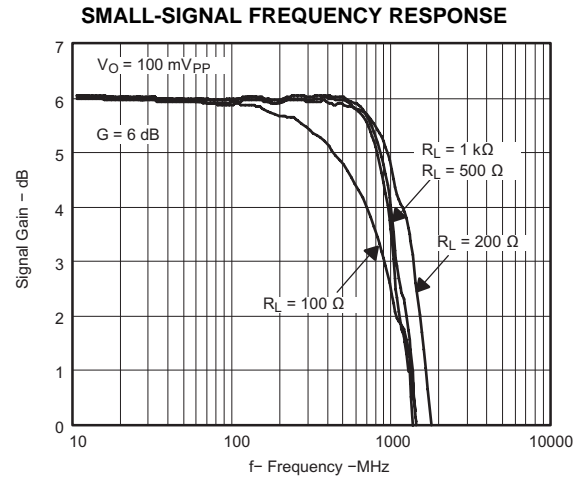

Figure 2.

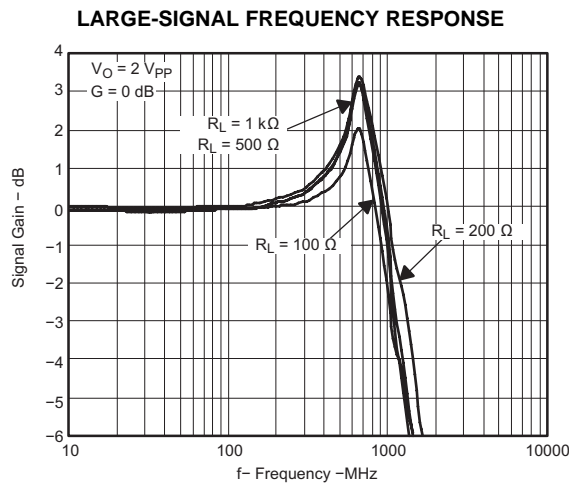

Figure 3.

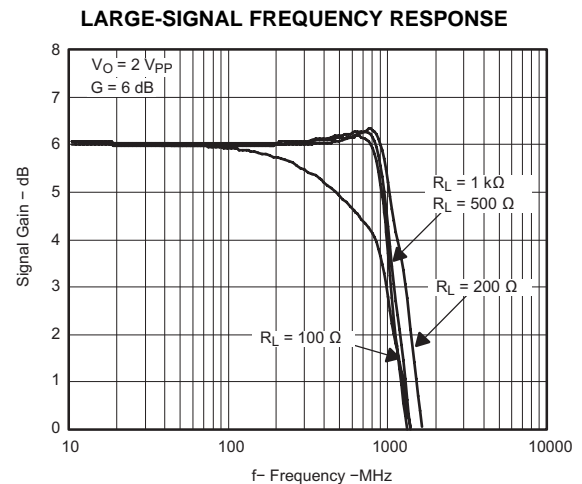

Figure 4.

TYPICAL CHARACTERISTICS: $V_{S+} - V_{S-} = 5\text{ V}$ (continued)

Test conditions unless otherwise noted: $V_{S+} = 5\text{ V}$, $V_{S-} = 0\text{ V}$, $G = 0\text{ dB}$, CM = open, $V_O = 2\text{ V}_{PP}$, $R_F = 349\ \Omega$, $R_L = 200\ \Omega$ differential, single-ended input, input referenced to ground, and output referenced to midrail.

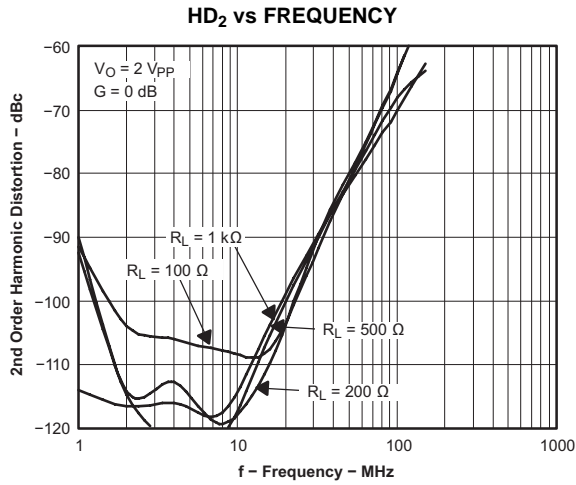

Figure 5.

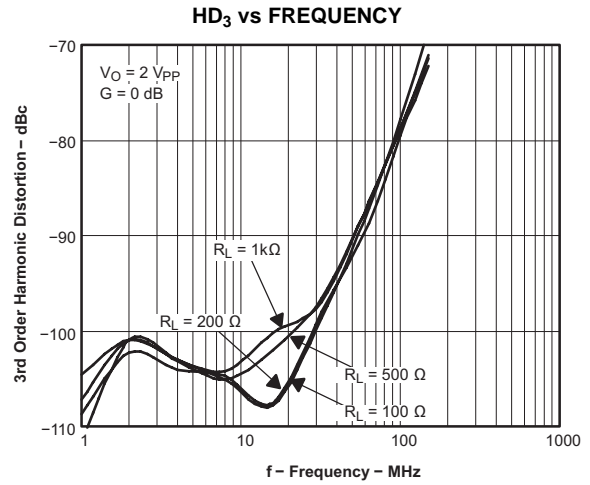

Figure 6.

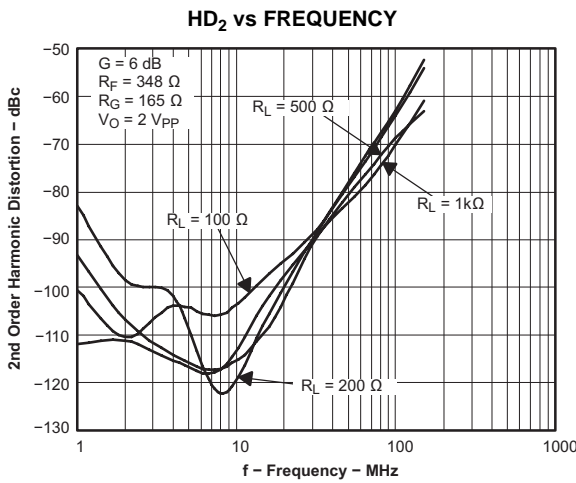

Figure 7.

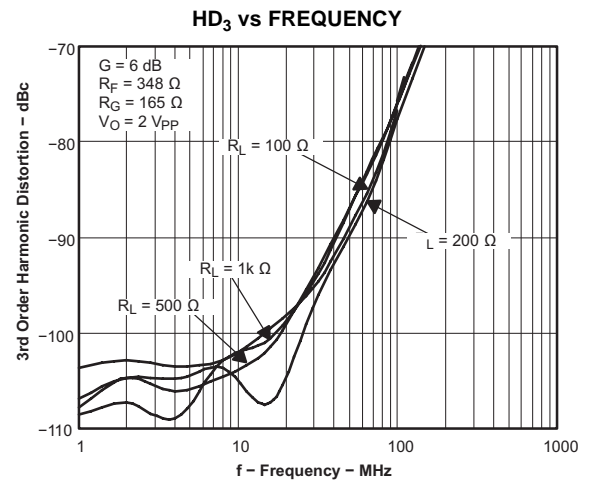

Figure 8.

TYPICAL CHARACTERISTICS: $V_{S+} - V_{S-} = 5\text{ V}$ (continued)

Test conditions unless otherwise noted: $V_{S+} = 5\text{ V}$, $V_{S-} = 0\text{ V}$, $G = 0\text{ dB}$, $\text{CM} = \text{open}$, $V_O = 2\text{ V}_{PP}$, $R_F = 349\ \Omega$, $R_L = 200\ \Omega$ differential, single-ended input, input referenced to ground, and output referenced to midrail.

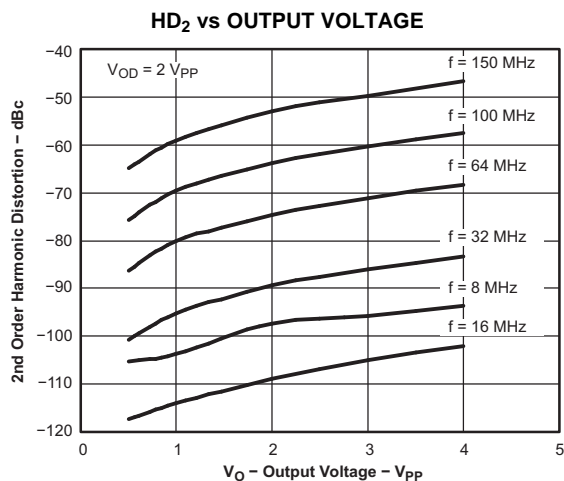

Figure 9.

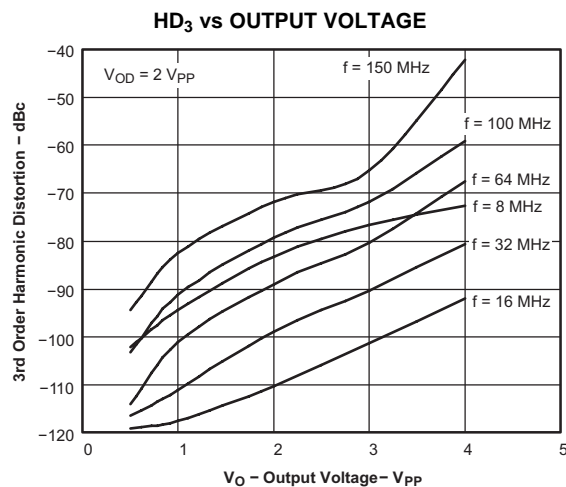

Figure 10.

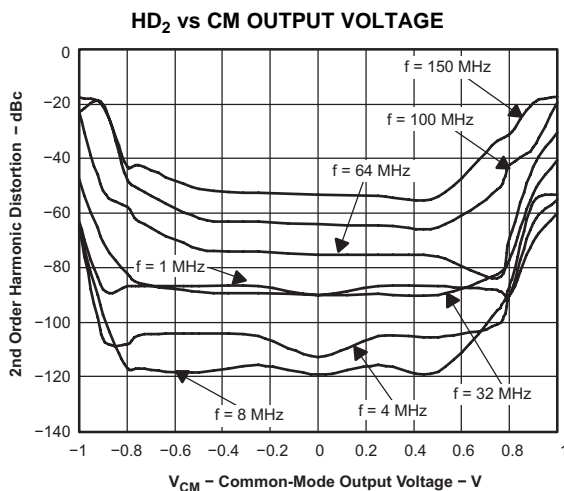

Figure 11.

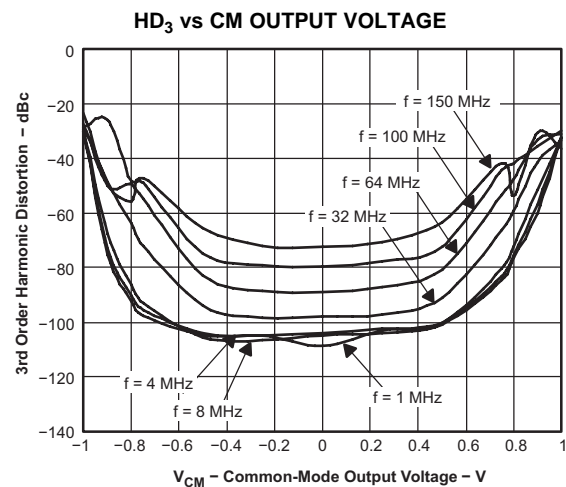
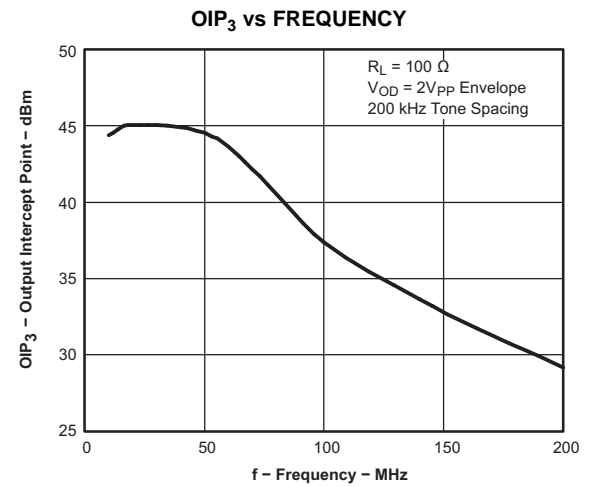
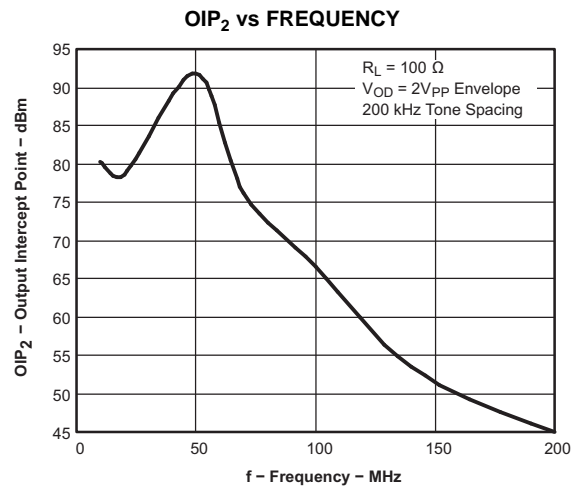
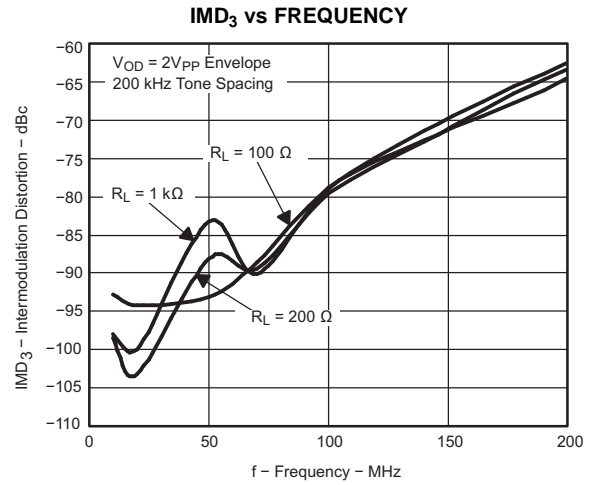
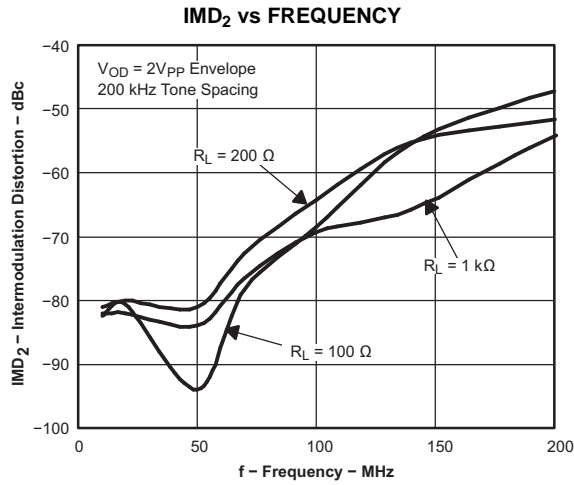

Figure 12.

TYPICAL CHARACTERISTICS: $V_{S+} - V_{S-} = 5\text{ V}$ (continued)

Test conditions unless otherwise noted: $V_{S+} = 5\text{ V}$, $V_{S-} = 0\text{ V}$, $G = 0\text{ dB}$, $CM = \text{open}$, $V_O = 2\text{ V}_{PP}$, $R_F = 349\ \Omega$, $R_L = 200\ \Omega$ differential, single-ended input, input referenced to ground, and output referenced to midrail.



TYPICAL CHARACTERISTICS: $V_{S+} - V_{S-} = 5\text{ V}$ (continued)

Test conditions unless otherwise noted: $V_{S+} = 5\text{ V}$, $V_{S-} = 0\text{ V}$, $G = 0\text{ dB}$, $CM = \text{open}$, $V_O = 2\text{ V}_{PP}$, $R_F = 349\ \Omega$, $R_L = 200\ \Omega$ differential, single-ended input, input referenced to ground, and output referenced to midrail.

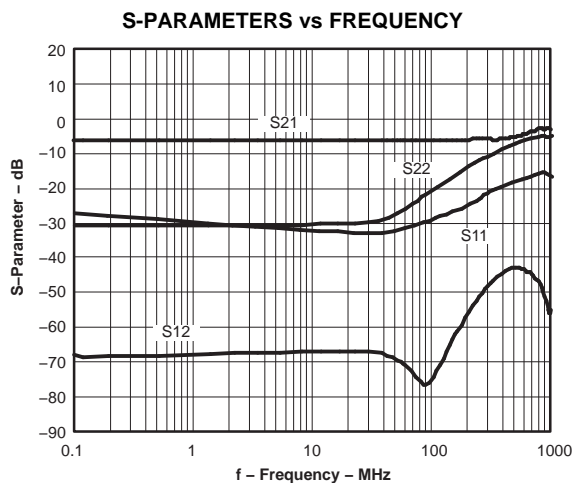

Figure 17.

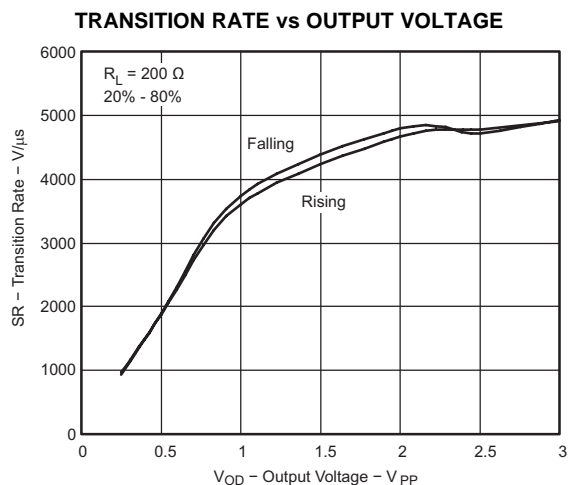

Figure 18.

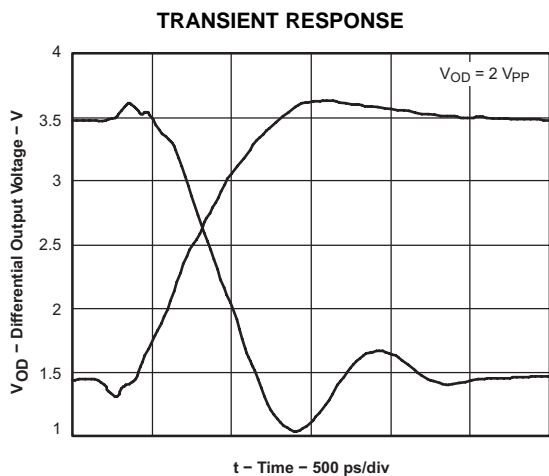

Figure 19.

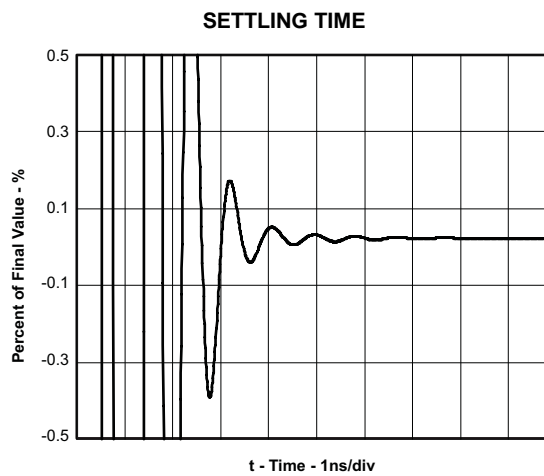

Figure 20.

TYPICAL CHARACTERISTICS: $V_{S+} - V_{S-} = 5\text{ V}$ (continued)

Test conditions unless otherwise noted: $V_{S+} = 5\text{ V}$, $V_{S-} = 0\text{ V}$, $G = 0\text{ dB}$, $\text{CM} = \text{open}$, $V_O = 2\text{ V}_{PP}$, $R_F = 349\ \Omega$, $R_L = 200\ \Omega$ differential, single-ended input, input referenced to ground, and output referenced to midrail.

REJECTION RATIOS vs FREQUENCY

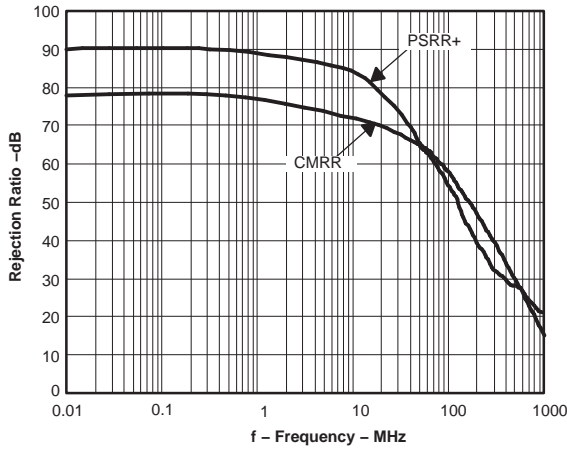

Figure 21.

OUTPUT IMPEDANCE vs FREQUENCY

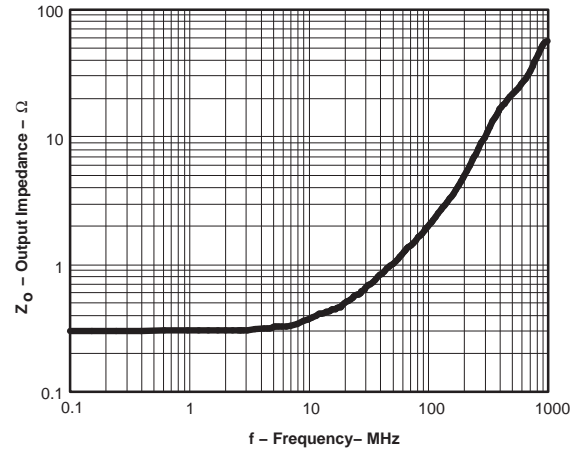

Figure 22.

OVERDRIVE RECOVERY

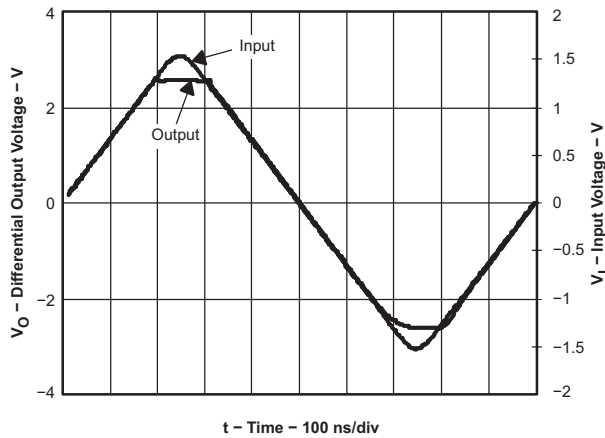

Figure 23.

DIFFERENTIAL OUTPUT VOLTAGE vs LOAD RESISTANCE

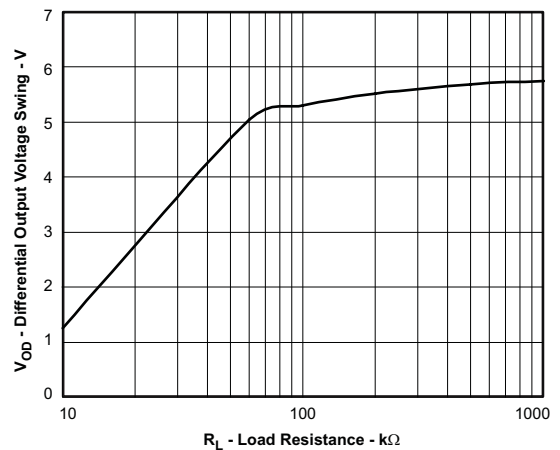

Figure 24.

TYPICAL CHARACTERISTICS: $V_{S+} - V_{S-} = 5\text{ V}$ (continued)

Test conditions unless otherwise noted: $V_{S+} = 5\text{ V}$, $V_{S-} = 0\text{ V}$, $G = 0\text{ dB}$, $CM = \text{open}$, $V_O = 2\text{ V}_{PP}$, $R_F = 349\ \Omega$, $R_L = 200\ \Omega$ differential, single-ended input, input referenced to ground, and output referenced to midrail.

TURN-OFF TIME

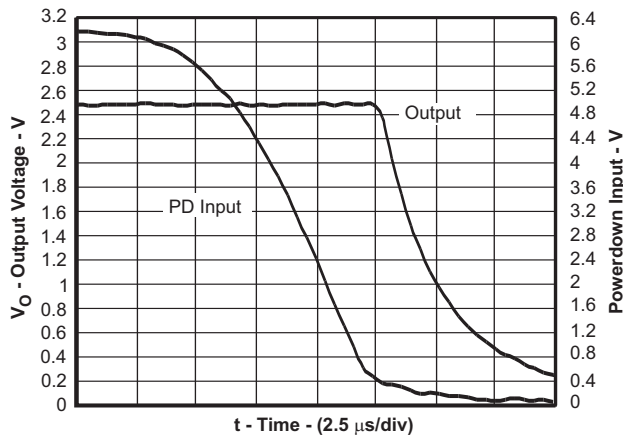

Figure 25.

TURN-ON TIME

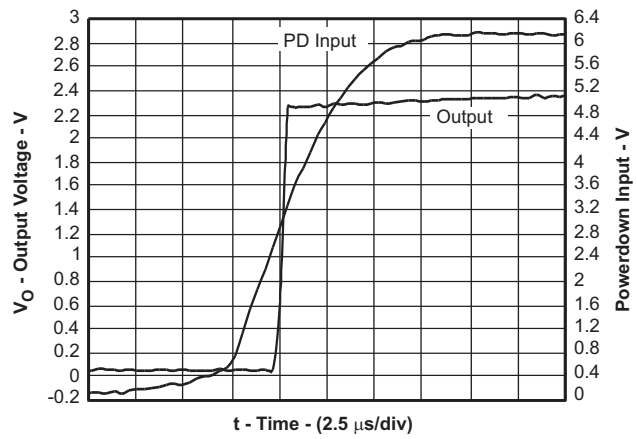

Figure 26.

INPUT OFFSET VOLTAGE vs INPUT COMMON-MODE VOLTAGE

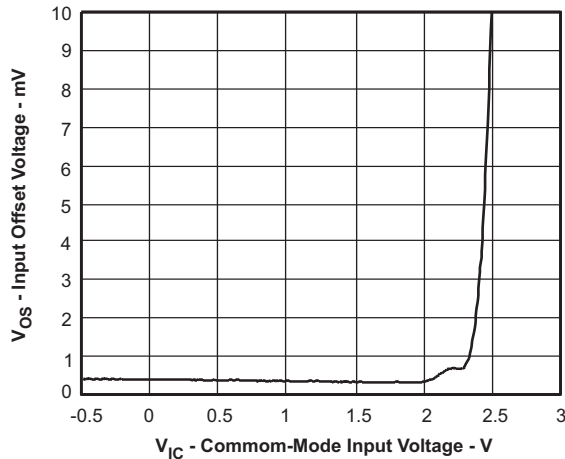

Figure 27.

OPEN-LOOP GAIN AND PHASE vs FREQUENCY

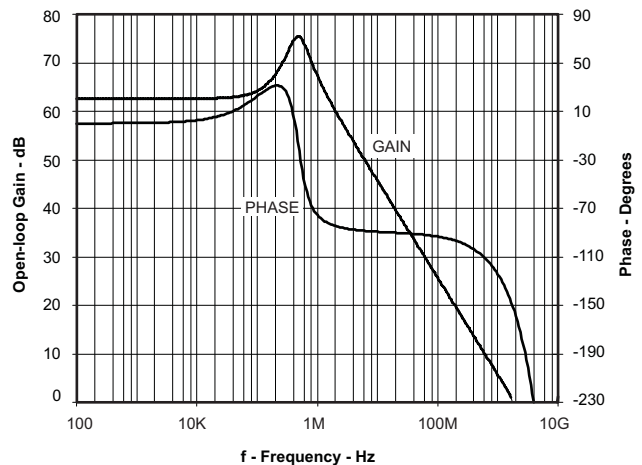

Figure 28.

TYPICAL CHARACTERISTICS: $V_{S+} - V_{S-} = 5\text{ V}$ (continued)

Test conditions unless otherwise noted: $V_{S+} = 5\text{ V}$, $V_{S-} = 0\text{ V}$, $G = 0\text{ dB}$, $CM = \text{open}$, $V_O = 2\text{ V}_{PP}$, $R_F = 349\ \Omega$, $R_L = 200\ \Omega$ differential, single-ended input, input referenced to ground, and output referenced to midrail.

INPUT-REFERRED NOISE vs FREQUENCY

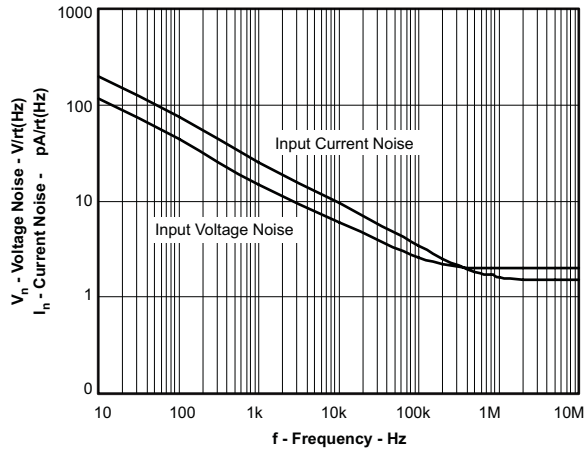

Figure 29.

NOISE FIGURE vs FREQUENCY

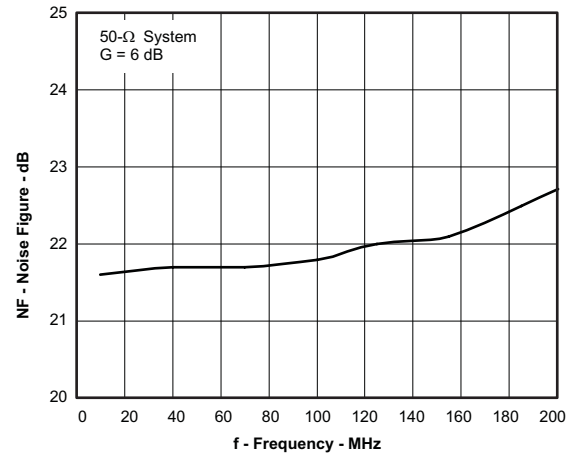

Figure 30.

QUIESCENT CURRENT vs SUPPLY VOLTAGE

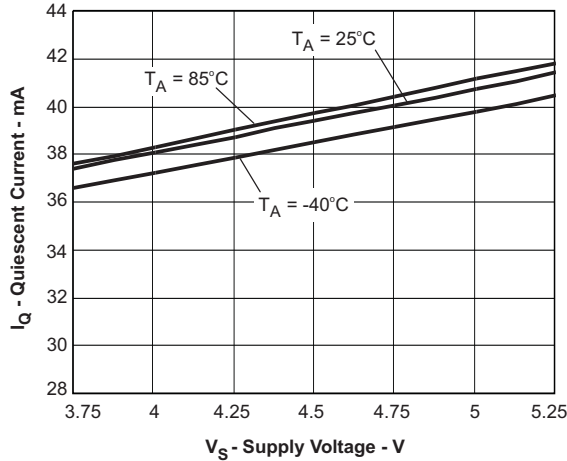

Figure 31.

OUTPUT BALANCE ERROR vs FREQUENCY

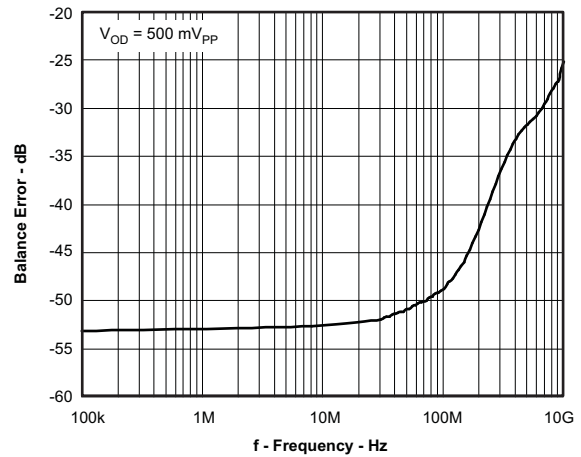

Figure 32.

TYPICAL CHARACTERISTICS: $V_{S+} - V_{S-} = 5\text{ V}$ (continued)

Test conditions unless otherwise noted: $V_{S+} = 5\text{ V}$, $V_{S-} = 0\text{ V}$, $G = 0\text{ dB}$, $CM = \text{open}$, $V_O = 2\text{ V}_{PP}$, $R_F = 349\ \Omega$, $R_L = 200\ \Omega$ differential, single-ended input, input referenced to ground, and output referenced to midrail.

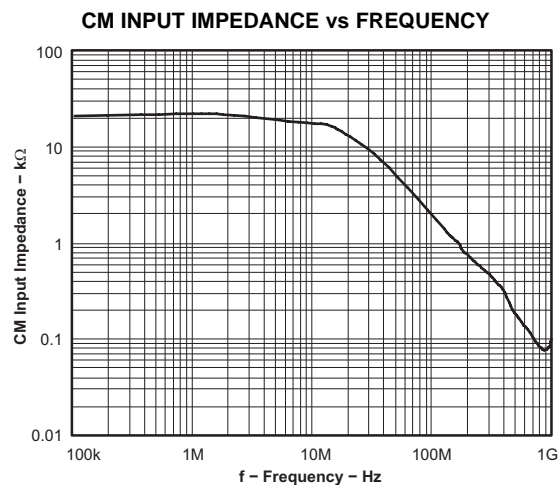

Figure 33.

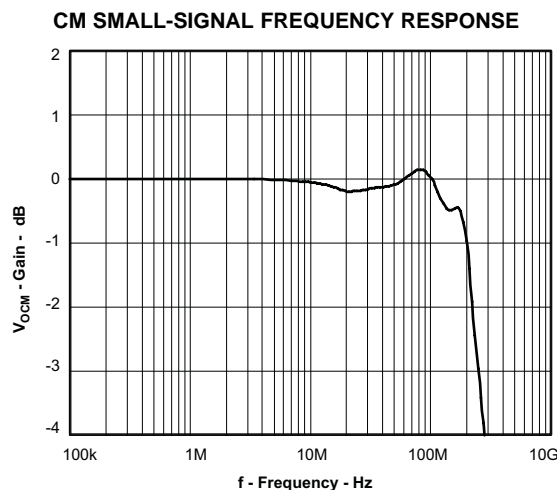

Figure 34.

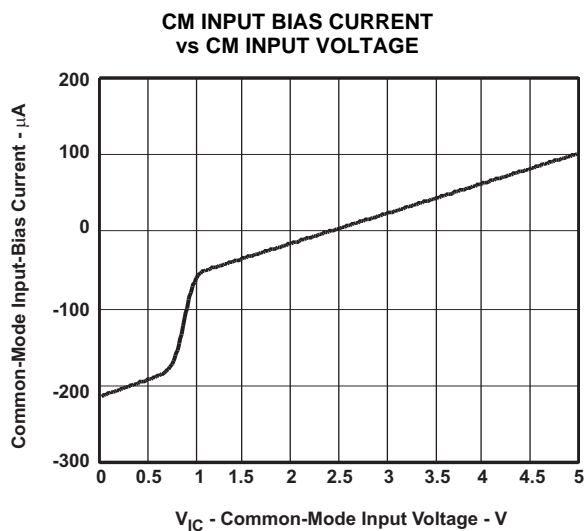

Figure 35.

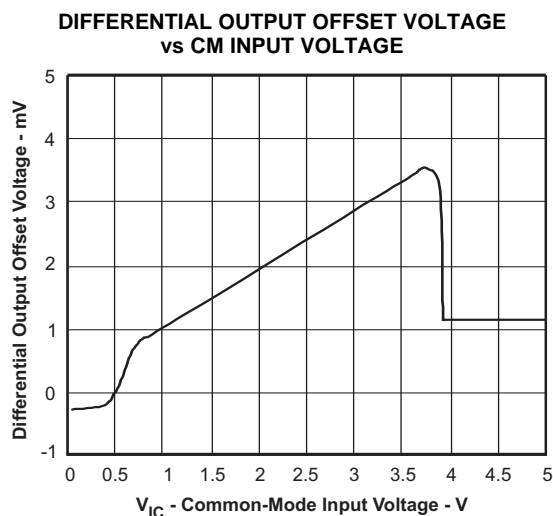

Figure 36.

TYPICAL CHARACTERISTICS: $V_{S+} - V_{S-} = 5\text{ V}$ (continued)

Test conditions unless otherwise noted: $V_{S+} = 5\text{ V}$, $V_{S-} = 0\text{ V}$, $G = 0\text{ dB}$, $\text{CM} = \text{open}$, $V_O = 2\text{ V}_{PP}$, $R_F = 349\ \Omega$, $R_L = 200\ \Omega$ differential, single-ended input, input referenced to ground, and output referenced to midrail.

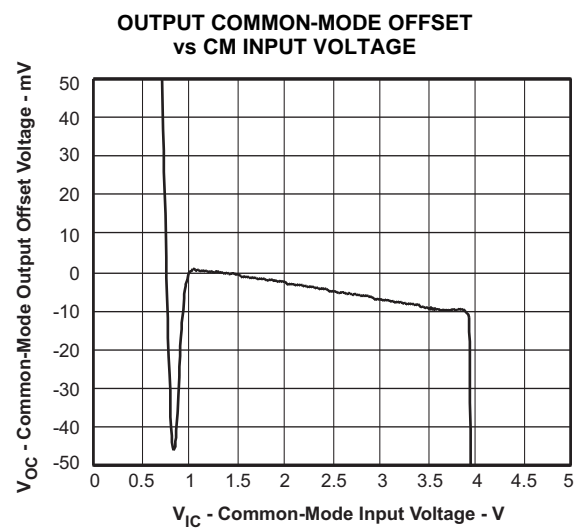

Figure 37.

TEST CIRCUITS

The THS4511 is tested with the following test circuits built on the evaluation module (EVM). For simplicity, the power-supply decoupling is not shown—see [Layout](#) in the [Application Information](#) section for recommendations. Depending on the test conditions, component values are changed per the following tables, or as otherwise noted. The signal generators used are ac-coupled 50-Ω sources, and a 0.22-μF capacitor and 49.9-Ω resistor to ground are inserted across R_{IT} on the alternate input to balance the circuit.

Table 1. Gain Component Values

GAIN	R_F	R_G	R_{IT}
0 dB	348 Ω	340 Ω	56.2 Ω
6 dB	348 Ω	165 Ω	61.9 Ω

Note the gain setting includes 50-Ω source impedance. Components are chosen to achieve gain and 50-Ω input termination.

Table 2. Load Component Values

R_L	R_O	R_{OT}	ATTEN.
100 Ω	25 Ω	Open	6 dB
200 Ω	86.6 Ω	69.8 Ω	16.8 dB
499 Ω	237 Ω	56.2 Ω	25.5 dB
1 kΩ	487 Ω	52.3 Ω	31.8 dB

Note the total load includes 50-Ω termination by the test equipment. Components are chosen to achieve load and 50-Ω line termination through a 1:1 transformer.

Due to the voltage divider on the output formed by the load component values, the amplifier output is attenuated. The column *Atten* in [Table 2](#) shows the attenuation expected from the resistor divider. When using a transformer at the output as shown in [Figure 39](#), the signal will see slightly more loss, and these numbers will be approximate.

Frequency Response

The circuit shown in [Figure 38](#) is used to measure the frequency response of the circuit.

A network analyzer is used as the signal source and as the measurement device. The output impedance of the network analyzer is 50 Ω. R_{IT} and R_G are chosen to impedance match to 50 Ω, and to maintain the proper gain. To balance the amplifier, a 0.22-μF capacitor and 49.9-Ω resistor to ground are inserted across R_{IT} on the alternate input.

The output is probed using a high-impedance differential probe across the 100-Ω resistor. The gain is referred to the amplifier output by adding back the 6-dB loss due to the voltage divider on the output.

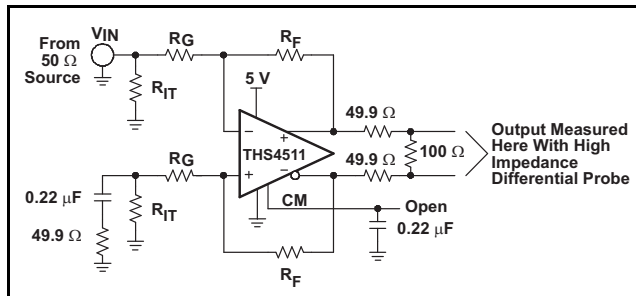

Figure 38. Frequency Response Test Circuit

Distortion and 1-dB Compression

The circuit shown in [Figure 39](#) is used to measure harmonic distortion, intermodulation distortion, and 1-dB compression point of the amplifier.

A signal generator is used as the signal source and the output is measured with a spectrum analyzer. The output impedance of the signal generator is 50 Ω. R_{IT} and R_G are chosen to impedance-match to 50 Ω, and to maintain the proper gain. To balance the amplifier, a 0.22-μF capacitor and 49.9-Ω resistor to ground are inserted across R_{IT} on the alternate input.

A low-pass filter is inserted in series with the input to reduce harmonics generated at the signal source. The level of the fundamental is measured, then a high-pass filter is inserted at the output to reduce the fundamental so that it does not generate distortion in the input of the spectrum analyzer.

The transformer used in the output to convert the signal from differential to single ended is an ADT1-1WT. It limits the frequency response of the circuit so that measurements cannot be made below approximately 1 MHz.

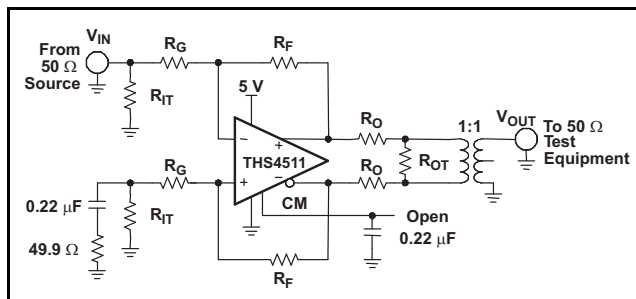

Figure 39. Distortion Test Circuit

The 1-dB compression point is measured with a spectrum analyzer with 50-Ω double termination or 100-Ω termination as shown in [Table 2](#). The input power is increased until the output is 1 dB lower than expected. The number reported in the table data is the power delivered to the spectrum analyzer input. Add 3 dB to refer to the amplifier output.

S-Parameter, Slew Rate, Transient Response, Settling Time, Output Impedance, Overdrive, Output Voltage, and Turn-On/Off Time

The circuit shown in Figure 40 is used to measure s-parameters, slew rate, transient response, settling time, output impedance, overdrive recovery, output voltage swing, and turn-on/turn-off times of the amplifier. For output impedance, the signal is injected at V_{OUT} with V_{IN} left open and the drop across the 49.9-Ω resistor is used to calculate the impedance seen looking into the amplifier output.

Because S_{21} is measured single-ended at the load with 50-Ω double termination, add 12 dB to refer to the amplifier output as a differential signal.

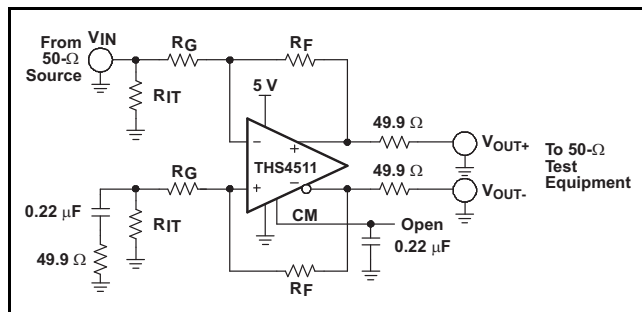

Figure 40. S-Parameter, SR, Transient Response, Settling Time, Z_O , Overdrive Recovery, V_{OUT} Swing, and Turn-On/Off Test Circuit

CM Input

The circuit shown in Figure 41 is used to measure the frequency response and input impedance of the CM input. Frequency response is measured single-ended at V_{OUT+} or V_{OUT-} with the input injected at V_{IN} , $R_{CM} = 0 \Omega$, and $R_{CMT} = 49.9 \Omega$. The input impedance is measured with $R_{CM} = 49.9 \Omega$ with $R_{CMT} = \text{open}$, and calculated by measuring the voltage drop across R_{CM} to determine the input current.

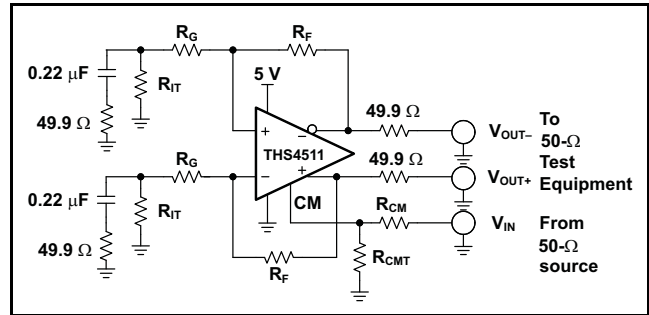

Figure 41. CM Input Test Circuit

CMRR and PSRR

The circuit shown in Figure 42 is used to measure the CMRR and PSRR of V_{S+} and V_{S-} . The input is switched appropriately to match the test being performed.

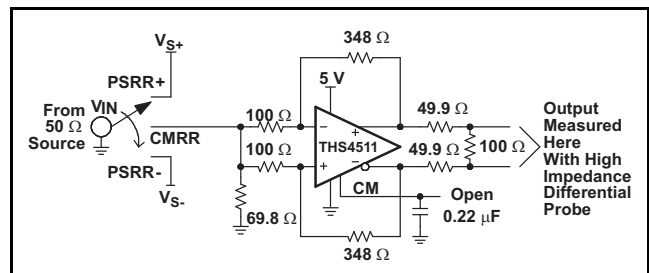

Figure 42. CMRR and PSRR Test Circuit

APPLICATION INFORMATION

APPLICATIONS

The following circuits show application information for the THS4511. For simplicity, power-supply decoupling capacitors are not shown in these diagrams. For more detail on the use and operation of fully-differential operational amplifiers refer to application report *Fully-Differential Amplifiers* (SLOA054).

Differential Input to Differential Output Amplifier

The THS4511 is a fully-differential operational amplifier, and can be used to amplify differential input signals to differential output signals. A basic block diagram of the circuit is shown in [Figure 43](#) (CM input not shown). The gain of the circuit is set by R_F divided by R_G .

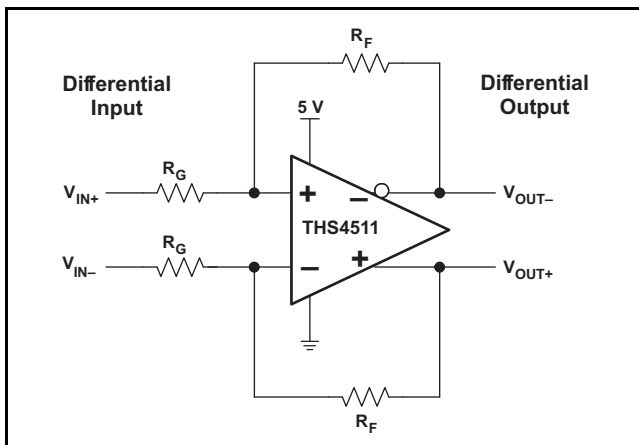

Figure 43. Differential Input to Differential Output Amplifier

Depending on the source and load, input and output termination can be accomplished by adding R_{IT} and R_O .

Single-Ended Input to Differential Output Amplifier

The THS4511 can be used to amplify and convert single-ended input signals to differential output signals. A basic block diagram of the circuit is shown in [Figure 44](#) (CM input not shown). The gain of the circuit is again set by R_F divided by R_G .

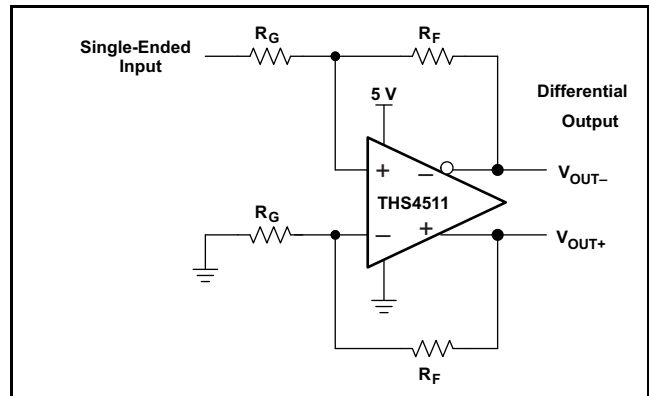

Figure 44. Single-Ended Input to Differential Output Amplifier

Input Common-Mode Voltage Range

The input common-mode voltage of a fully-differential operational amplifier is the voltage at the (+) and (-) input pins of the operational amplifier.

It is important to not violate the input common-mode voltage range (V_{ICR}) of the operational amplifier. Assuming the operational amplifier is in linear operation the voltage across the input pins is only a few millivolts at most. So finding the voltage at one input pin determines the input common-mode voltage of the operational amplifier.

Treating the negative input as a summing node, the voltage is given by [Equation 1](#):

$$V_{IC} = \left(V_{OUT+} \times \frac{R_G}{R_G + R_F} \right) + \left(V_{IN-} \times \frac{R_F}{R_G + R_F} \right) \quad (1)$$

To determine the V_{ICR} of the operational amplifier, the voltage at the negative input is evaluated at the extremes of V_{OUT+} .

As the gain of the operational amplifier increases, the input common-mode voltage becomes closer and closer to the input common-mode voltage of the source.

Setting the Output Common-Mode Voltage

The output common-mode voltage is set by the voltage at the CM pin(s). The internal common-mode control circuit maintains the output common-mode voltage within 5-mV offset (typical) from the set voltage, when set within 0.5 V of midsupply. If left unconnected, the common-mode set point is set to midsupply by internal circuitry, which may be overdriven from an external source. Figure 45 is representative of the CM input. The internal CM circuit has about 700 MHz of –3-dB bandwidth, which is required for best performance, but it is intended to be a dc-bias input pin. Bypass capacitors are recommended on this pin to reduce noise at the output. The external current required to overdrive the internal resistor divider is given by Equation 2:

$$I_{EXT} = \frac{2V_{CM} - (V_{S+} - V_{S-})}{50\text{ k}\Omega} \quad (2)$$

where V_{CM} is the voltage applied to the CM pin, and V_{S+} ranges from 3.75 V to 5 V, and V_{S-} is 0 V (ground).

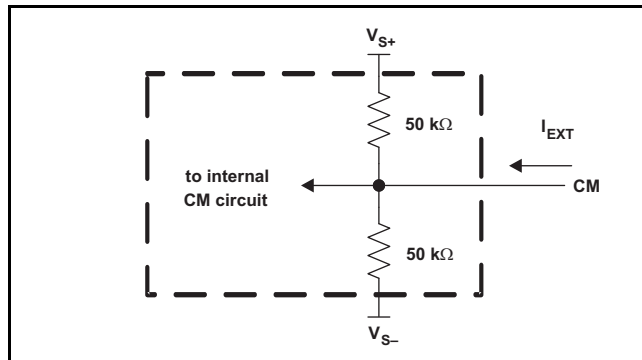

Figure 45. CM Input Circuit

Device Operation with Single Power Supplies Less than 5 V

The THS4511 is optimized to work in systems using 5-V single supplies, and the characterization data presented in this data sheet were taken with 5-V single-supply inputs. For ac-coupled systems or dc-coupled systems operating with supplies less than 5 V and greater than 3.75 V, the amplifier input common-mode range is maximized by adding pull-down resistors at the device inputs. The pull-down resistors provide additional loading at the input, and lower the common-mode voltage that is fed back into the device input through resistor R_F . Figure 46 shows the circuit configuration for this mode of operation where R_{PD} is added to the dc-coupled circuit to avoid violating the V_{ICR} of the

operational amplifier. Note R_S and R_{IT} are added to the alternate input from the signal input to balance the amplifier. One resistor that is equal to the combined value $R_I = R_G + R_S \parallel R_{IT}$ can be placed at the alternate input.

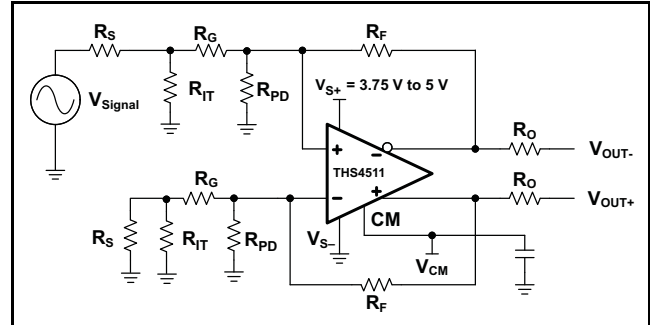

Figure 46. THS4511 DC-Coupled Single-Source Supply Range From 3.75 V to 5 V With R_{PD} Used To Set V_{IC}

Note that in Figure 46, the source is referenced to ground, as is the input termination resistor R_{IT} . The proper value of resistance to add can be calculated from Equation 3:

$$R_{PD} = \frac{1}{\frac{1}{R_F} \left[\frac{1.6}{\frac{V_{S+}}{2} - 1.6} \right] - \frac{1}{R_I}} \quad (3)$$

where $R_I = R_G + R_S \parallel R_{IT}$.

V_{S+} is the power-supply voltage, R_F is the feedback resistance, R_G is the gain-setting resistance, R_S is the signal source resistance, and R_{IT} is the termination resistance.

Table 3 is a modification of Table 1 to add the proper values with R_{PD} assuming $V_{S+} = 3.75$ V, a dc-coupled 50-Ω source impedance, and setting the output common-mode voltage to midsupply.

Table 3. R_{PD} Values for Various Gains, $V_{S+} = 3.75$ V, DC-coupled Signal Source

GAIN	R_F	R_G	R_{IT}	R_{PD}
0 dB	348 Ω	340 Ω	56.2 Ω	422 Ω
6 dB	348 Ω	169 Ω	64.9 Ω	86.6 Ω

If the signal originates from an ac-coupled 50-Ω source (see Figure 47), the equivalent dc-source resistance is an open circuit and $R_I = R_G + R_{IT}$. Table 4 is a modification of Table 1 to add the proper values with R_{PD} assuming $V_{S+} = 3.75$ V, an ac-coupled 50-Ω source impedance, and setting the output common-mode voltage to midsupply.

Table 4. R_{PD} Values for Various Gains, $V_{S+} = 3.75$ V, AC-Coupled Signal Source

GAIN	R_F	R_G	R_{IT}	R_{PD}
0 dB	348 Ω	340 Ω	56.2 Ω	390 Ω
6 dB	348 Ω	169 Ω	64.9 Ω	80.6 Ω

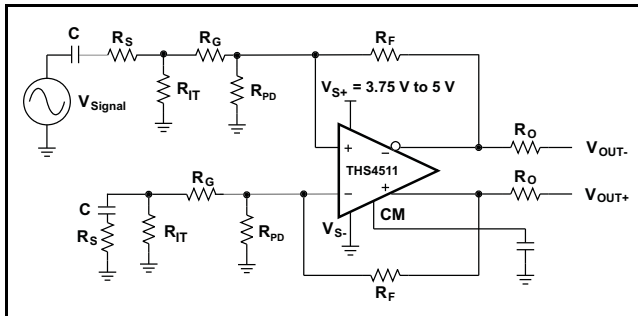

Figure 47. THS4511 AC-Coupled Single-Source Supply Range From 3.75 V to 5 V With R_{PD} Used To Set V_{IC}

Video Buffer

Figure 48 shows a possible application of the THS4508 as a dc-coupled video buffer with a gain of 2. Figure 49 shows a plot of the Y' signal originating from an HDTV 720p video system. The input signal includes a 3-level sync (minimum level at -0.3 V) and the portion of a video signal with maximum amplitude of 0.7 V. Although the buffer draws its power from a 5-V single-ended power supply, internal level shifters allow the buffer to support input signals which are as much as -0.3 V below ground. This allows maximum design flexibility while maintaining a minimum parts count. Figure 50 shows the differential output of the buffer. Note that the dc-coupled amplifier can introduce a dc offset on a signal applied at its input.

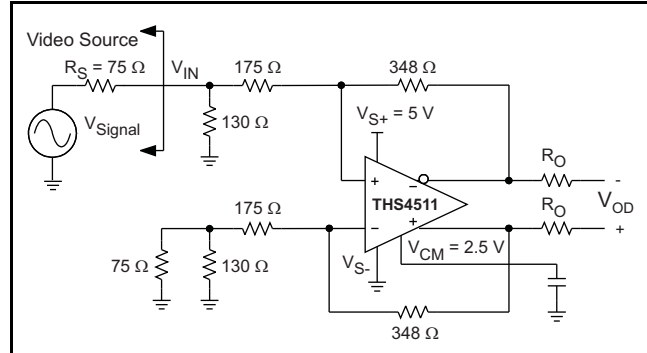

Figure 48. Single-Supply Video Buffer, Gain = 2

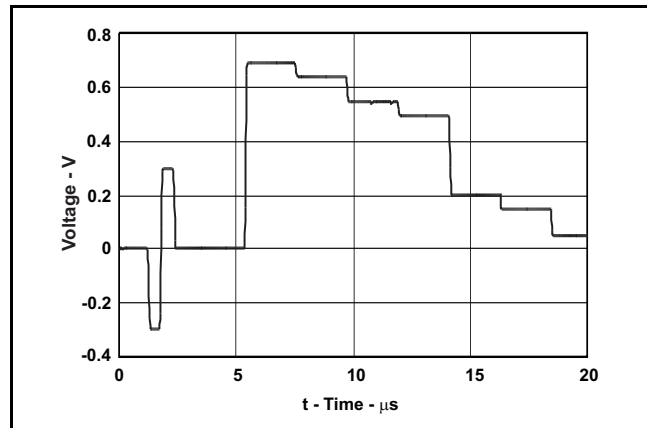

Figure 49. Y' Signal with 3-Level Sync and Video Signal

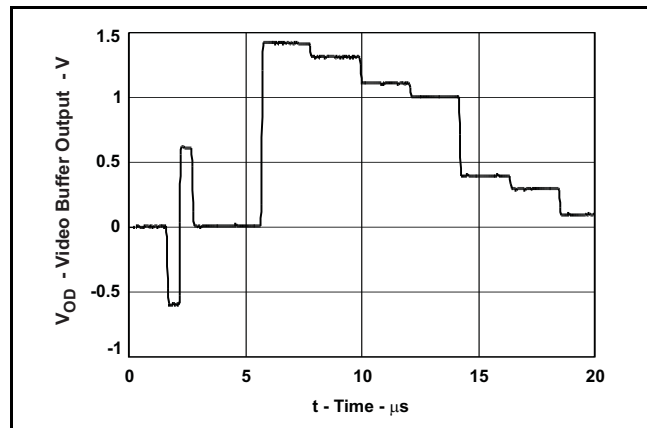

Figure 50. Video Buffer Differential Output Signal

THS4511 and ADS5500 Combined Performance

The THS4511 is designed to be a high-performance drive amplifier for high-performance data converters like the ADS5500 14-bit 125-MSPS ADC. Figure 51 shows a circuit combining the two devices. The THS4511 amplifier circuit provides 0 dB of gain, and converts the single-ended input signal to a differential output signal. The default common-mode output of the THS4511 (2.5 V) is not compatible with the required common-mode input of the ADS5500 (1.55 V), so dc-blocking capacitors are added (0.22 μ F). Note that a biasing circuit (not shown in Figure 51) is needed to provide the required common-mode, dc-input for the ADS5500. The 100- Ω resistors and 2.7-pF capacitor between the THS4511 outputs and ADS5500 inputs along with the input capacitance of the ADS5500 limit the bandwidth of the signal to 115 MHz (-3 dB). For testing, a signal generator is used for the signal source. The generator is an ac-coupled 50- Ω source. A band-pass filter is inserted in series with the input to reduce harmonics and noise from the signal source. Input termination is accomplished via the 69.8- Ω resistor and 0.22- μ F capacitor to ground in conjunction with the input impedance of the amplifier circuit. A 0.22- μ F capacitor and 49.9- Ω resistor is inserted to ground across the 69.8- Ω resistor and 0.22- μ F capacitor on the alternate input to balance the circuit. Gain is a function of the source impedance, termination, and 348- Ω feedback resistor. See Table 1 for component values to set proper 50- Ω termination for other common gains.

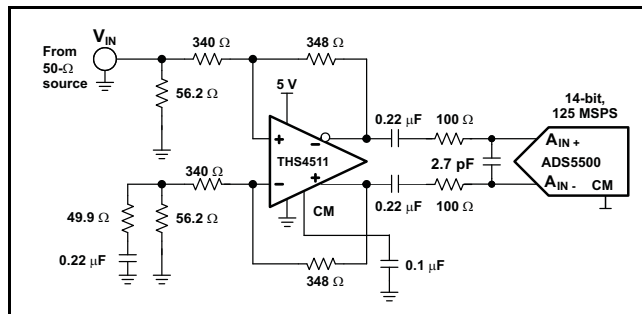

Figure 51. THS4511 and ADS5500 Circuit

THS4511 and ADS5424 Combined Performance

Figure 52 shows the THS4511 driving the ADS5424 ADC.

As before, the THS4511 amplifier provides 0 dB of gain, converts the single-ended input to differential, and sets the proper input common-mode voltage to the ADS5424. Input termination and circuit testing is the same as described above for the THS4511 and ADS5500 circuit.

The 225- Ω resistors and 2.7-pF capacitor between the THS4511 outputs and ADS5424 inputs (along with the input capacitance of the ADC) limit the bandwidth of the signal to about 100 MHz (-3 dB).

When the THS4511 is operated from a single power supply with $V_{S+} = 5$ V and $V_{S-} =$ ground, the 2.5-V output common-mode voltage is compatible with the recommended value of the ADS5424 input common-mode voltage (2.4 V).

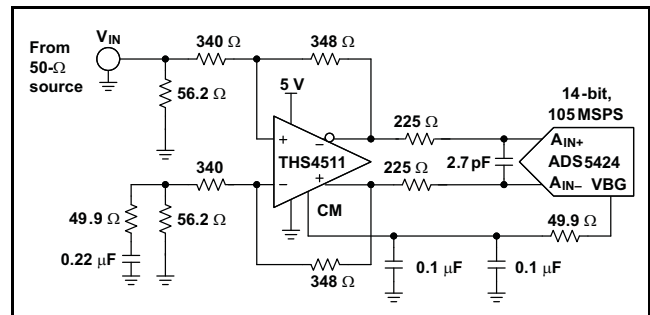

Figure 52. THS4511 and ADS5424 Circuit

Layout Recommendations

It is recommended to follow the layout of the external components near the amplifier, ground plane construction, and power routing of the EVM as closely as possible. General guidelines are:

1. Signal routing should be direct and as short as possible into and out of the operational amplifier circuit.
2. The feedback path should be short and direct; avoid vias.
3. Ground or power planes should be removed from directly under the amplifier input and output pins.
4. An output resistor is recommended on each output, as near to the output pin as possible.
5. Two 10- μ F and two 0.1- μ F power-supply decoupling capacitors should be placed as near to the power-supply pins as possible.
6. Two 0.1- μ F capacitors should be placed between the CM input pins and ground. This configuration limits noise coupled into the pins. One each should be placed to ground near pin 4 and pin 9.
7. It is recommended to split the ground plane on layer 2 (L2) as shown below and to use a solid ground on layer 3 (L3). A single-point connection should be used between each split section on L2 and L3.
8. A single-point connection to ground on L2 is recommended for the input termination resistors R1 and R2. This configuration should be applied to the input gain resistors if termination is not used.
9. The recommended printed circuit board (PCB) footprint for the THS4511 is shown in [Figure 54](#).

PowerPAD™ DESIGN CONSIDERATIONS

The THS4511 is available in a thermally-enhanced PowerPAD family of packages. These packages are constructed using a downset leadframe on which the die is mounted (see [Figure 53a](#) and [Figure 53b](#)). This arrangement results in the lead frame being exposed

as a thermal pad on the underside of the package (see [Figure 53c](#)). Because this thermal pad has direct thermal contact with the die, excellent thermal performance can be achieved by providing a good thermal path away from the thermal pad.

Note that the THS4511 has no electrical connection between the PowerPAD and circuitry on the die. Connecting the PowerPAD to any potential voltage between V_{S+} and V_{S-} is acceptable. It is most important that it be connected for maximum heat dissipation.

The PowerPAD package allows both assembly and thermal management in one manufacturing operation.

During the surface-mount solder operation (when the leads are being soldered), the thermal pad can also be soldered to a copper area underneath the package. Through the use of thermal paths within this copper area, heat can be conducted away from the package into either a ground plane or other heat dissipating device.

The PowerPAD package represents a breakthrough in combining the small area and ease of assembly of surface-mount with the heretofore awkward mechanical methods of heatsinking.

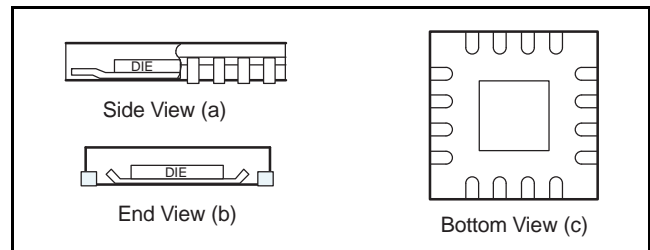

Figure 53. Views of Thermally-Enhanced Package

Table 5. THS4511RGT EVM Bill of Materials

ITEM	DESCRIPTION	SMD SIZE	REFERENCE DESIGNATOR	PCB QTY	MANUFACTURER PART NUMBER ⁽¹⁾
1	CAP, 10.0 μ F, Ceramic, X5R, 6.3V	0805	C3, C5	2	(AVX) 08056D106KAT2A
2	CAP, 0.1 μ F, Ceramic, X5R, 10V	0402	C11-C14	4	(AVX) 0402ZD104KAT2A
3	CAP, 0.22 μ F, Ceramic, X5R, 6.3V	0402	C15	1	(AVX) 04026D224KAT2A
4	OPEN	0402	C1, C2, C7-C10	6	
5	OPEN	0402	R9, R10	2	
6	Resistor, 49.9 Ω , 1/16W, 1%	0402	R12	1	(KOA) RK73H1ETTP49R9F
7	Resistor, 56.2 Ω , 1/16W, 1%	0402	R1, R2		(KOA) RK73H1ETTP56R2F
8	Resistor, 69.8 Ω , 1/16W, 1%	0402	R11	3	(KOA) RK73H1ETTP69R8F
9	Resistor, 86.6 Ω , 1/16W, 1%	0402	R7, R8	2	(KOA) RK73H1ETTP86R6F
10	Resistor, 340 Ω , 1/16W, 1%	0402	R3, R4	2	(KOA) RK73H1ETTP3400F
11	Resistor, 348 Ω , 1/16W, 1%	0402	R5, R6	2	(KOA) RK73H1ETTP3480F
12	Resistor, 0 Ω , 5%	0805	C4, C6	2	(KOA) RK73Z2ATTD
13	Transformer, RF		T1	1	(MINI-CIRCUITS) ADT1-1WT
14	Jack, banana receptance, 0.25" diameter hole		J5, J6	2	(HH SMITH) 101
15	OPEN		J1, J7, J8	3	
16	Connector, edge, SMA PCB Jack		J2, J3	2	(JOHNSON) 142-0701-801
17	Test point, Red		TP1, TP2, TP3	3	(KEYSTONE) 5000
18	IC, THS4511		U1	1	(TI) THS4511RGT
19	Standoff, 4-40 HEX, 0.625" length			4	(KEYSTONE) 1808
20	SCREW, PHILLIPS, 4-40, 0.250"			4	SHR-0440-016-SN
21	Printed circuit board			1	(TI) EDGE# 6475513

(1) The manufacturer's part numbers were used for test purposes only.

EVM WARNINGS AND RESTRICTIONS

It is important to operate this EVM within the input and output voltage ranges as specified in the table provided below.

INPUT RANGE, V_{S+} TO V_{S-}	3.0 V TO 6.0 V
Input Range, V_I	3.0 V to 6.0 V NOT TO EXCEED V_{S+} or V_{S-}
Output Range, V_O	3.0 V to 6.0 V NOT TO EXCEED V_{S+} or V_{S-}

Exceeding the specified input range may cause unexpected operation and/or irreversible damage to the EVM. If there are questions concerning the input range, please contact a TI field representative prior to connecting the input power.

Applying loads outside of the specified output range may result in unintended operation and/or possible permanent damage to the EVM. Please consult the product data sheet or EVM user's guide (if user's guide is available) prior to connecting any load to the EVM output. If there is uncertainty as to the load specification, please contact a TI field representative.

During normal operation, some circuit components may have case temperatures greater than +30°C. The EVM is designed to operate properly with certain components above +50°C as long as the input and output ranges are maintained. These components include but are not limited to linear regulators, switching transistors, pass transistors, and current sense resistors. These types of devices can be identified using the EVM schematic located in the material provided. When placing measurement probes near these devices during operation, please be aware that these devices may be very warm to the touch.



Mailing Address: Texas Instruments Post Office Box 655303 Dallas, Texas 75265

REVISION HISTORY

NOTE: Page numbers for previous revisions may differ from page numbers in the current version.

Changes from Revision D (May 2007) to Revision E	Page
• Updated document format to match current standards	1
• Deleted title and conditions of Typical Conditions table of graphs	6
• Added title and conditions to Typical Characteristics plots	7
• Changed item 9 in the <i>Layout Recommendations</i> section	23
• Added <i>PowerPAD Design Considerations</i> section	23
• Added <i>PowerPAD PCB Layout Considerations</i> section	24
• Moved Figure 54 and associated paragraph to <i>PowerPAD PCB Layout Considerations</i> section	24

PACKAGING INFORMATION

Orderable Device	Status (1)	Package Type	Package Drawing	Pins	Package Qty	Eco Plan (2)	Lead/Ball Finish (6)	MSL Peak Temp (3)	Op Temp (°C)	Device Marking (4/5)	Samples
THS4511RGTR	OBSOLETE	QFN	RGT	16		TBD	Call TI	Call TI	-40 to 85		
THS4511RGTRG4	OBSOLETE	QFN	RGT	16		TBD	Call TI	Call TI	-40 to 85		
THS4511RGTT	ACTIVE	QFN	RGT	16	250	Green (RoHS & no Sb/Br)	CU NIPDAU	Level-2-260C-1 YEAR	-40 to 85	4511	
THS4511RGTTG4	ACTIVE	QFN	RGT	16	250	Green (RoHS & no Sb/Br)	CU NIPDAU	Level-2-260C-1 YEAR	-40 to 85	4511	

(1) The marketing status values are defined as follows:

ACTIVE: Product device recommended for new designs.

LIFEBUY: TI has announced that the device will be discontinued, and a lifetime-buy period is in effect.

NRND: Not recommended for new designs. Device is in production to support existing customers, but TI does not recommend using this part in a new design.

PREVIEW: Device has been announced but is not in production. Samples may or may not be available.

OBSOLETE: TI has discontinued the production of the device.

(2) Eco Plan - The planned eco-friendly classification: Pb-Free (RoHS), Pb-Free (RoHS Exempt), or Green (RoHS & no Sb/Br) - please check <http://www.ti.com/productcontent> for the latest availability information and additional product content details.

TBD: The Pb-Free/Green conversion plan has not been defined.

Pb-Free (RoHS): TI's terms "Lead-Free" or "Pb-Free" mean semiconductor products that are compatible with the current RoHS requirements for all 6 substances, including the requirement that lead not exceed 0.1% by weight in homogeneous materials. Where designed to be soldered at high temperatures, TI Pb-Free products are suitable for use in specified lead-free processes.

Pb-Free (RoHS Exempt): This component has a RoHS exemption for either 1) lead-based flip-chip solder bumps used between the die and package, or 2) lead-based die adhesive used between the die and leadframe. The component is otherwise considered Pb-Free (RoHS compatible) as defined above.

Green (RoHS & no Sb/Br): TI defines "Green" to mean Pb-Free (RoHS compatible), and free of Bromine (Br) and Antimony (Sb) based flame retardants (Br or Sb do not exceed 0.1% by weight in homogeneous material)

(3) MSL, Peak Temp. - The Moisture Sensitivity Level rating according to the JEDEC industry standard classifications, and peak solder temperature.

(4) There may be additional marking, which relates to the logo, the lot trace code information, or the environmental category on the device.

(5) Multiple Device Markings will be inside parentheses. Only one Device Marking contained in parentheses and separated by a "~" will appear on a device. If a line is indented then it is a continuation of the previous line and the two combined represent the entire Device Marking for that device.

(6) Lead/Ball Finish - Orderable Devices may have multiple material finish options. Finish options are separated by a vertical ruled line. Lead/Ball Finish values may wrap to two lines if the finish value exceeds the maximum column width.

Important Information and Disclaimer: The information provided on this page represents TI's knowledge and belief as of the date that it is provided. TI bases its knowledge and belief on information provided by third parties, and makes no representation or warranty as to the accuracy of such information. Efforts are underway to better integrate information from third parties. TI has taken and

continues to take reasonable steps to provide representative and accurate information but may not have conducted destructive testing or chemical analysis on incoming materials and chemicals. TI and TI suppliers consider certain information to be proprietary, and thus CAS numbers and other limited information may not be available for release.

In no event shall TI's liability arising out of such information exceed the total purchase price of the TI part(s) at issue in this document sold by TI to Customer on an annual basis.

OTHER QUALIFIED VERSIONS OF THS4511 :

- Space: [THS4511-SP](#)

NOTE: Qualified Version Definitions:

- Space - Radiation tolerant, ceramic packaging and qualified for use in Space-based application

TAPE AND REEL INFORMATION

REEL DIMENSIONS

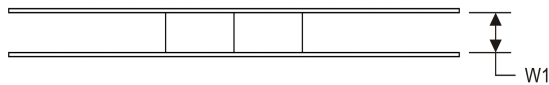
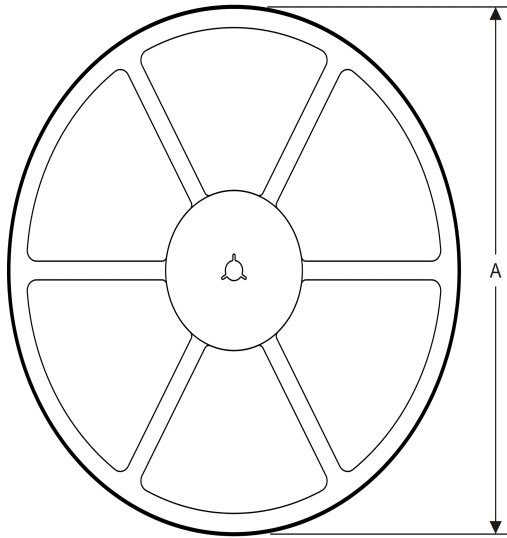

TAPE DIMENSIONS

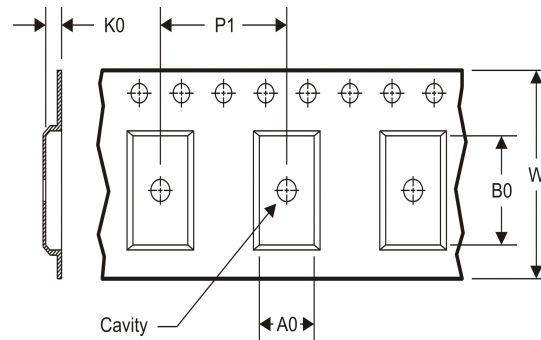

A0	Dimension designed to accommodate the component width
B0	Dimension designed to accommodate the component length
K0	Dimension designed to accommodate the component thickness
W	Overall width of the carrier tape
P1	Pitch between successive cavity centers

TAPE AND REEL INFORMATION

*All dimensions are nominal

Device	Package Type	Package Drawing	Pins	SPQ	Reel Diameter (mm)	Reel Width W1 (mm)	A0 (mm)	B0 (mm)	K0 (mm)	P1 (mm)	W (mm)	Pin1 Quadrant
THS4511RGTT	QFN	RGT	16	250	180.0	12.4	3.3	3.3	1.1	8.0	12.0	Q2

TAPE AND REEL BOX DIMENSIONS



*All dimensions are nominal

Device	Package Type	Package Drawing	Pins	SPQ	Length (mm)	Width (mm)	Height (mm)
THS4511RGTT	QFN	RGT	16	250	210.0	185.0	35.0

RGT (S-PVQFN-N16)

PLASTIC QUAD FLATPACK NO-LEAD

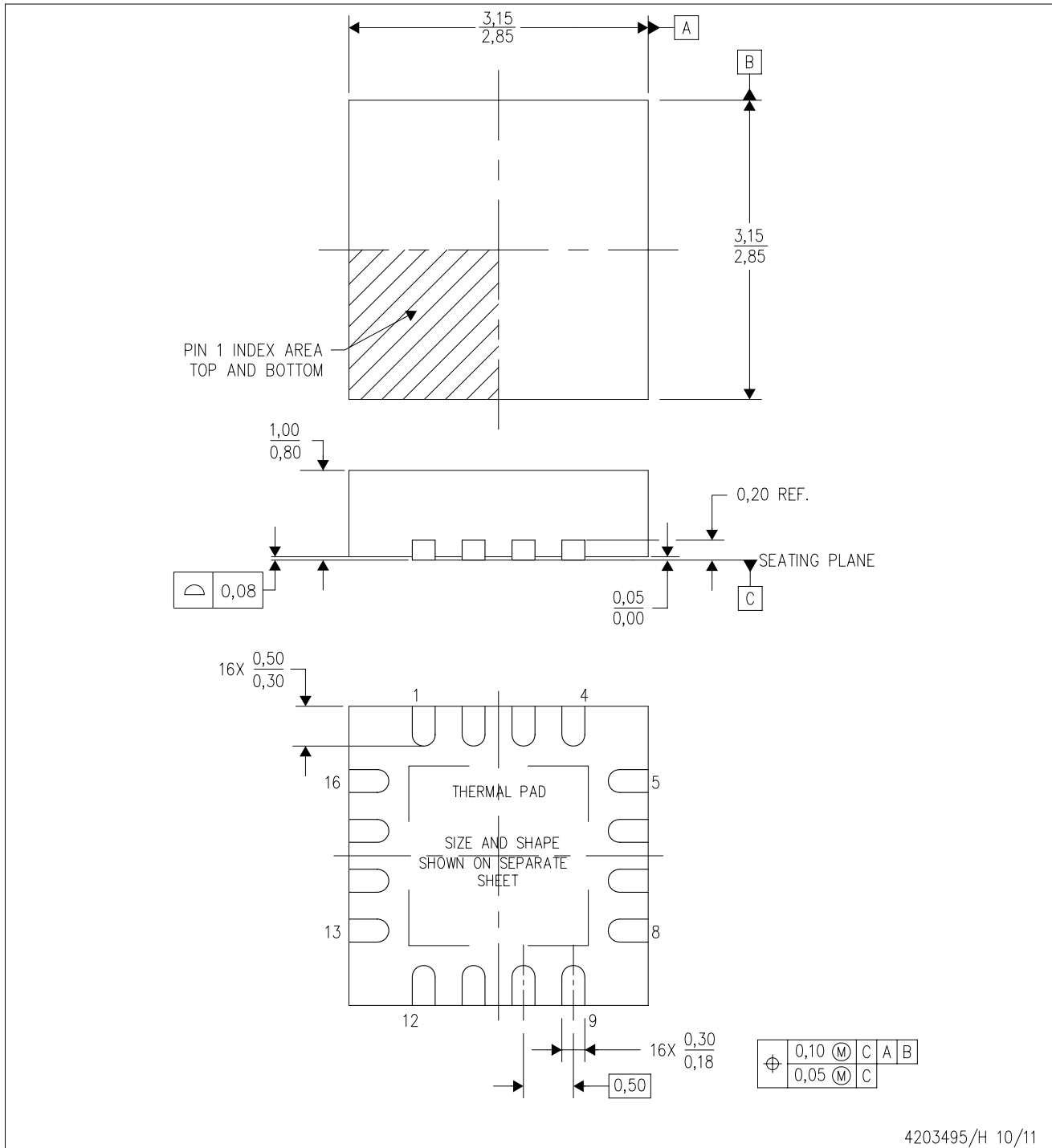

4203495/H 10/11

- NOTES:
- All linear dimensions are in millimeters. Dimensioning and tolerancing per ASME Y14.5M-1994.
 - This drawing is subject to change without notice.
 - Quad Flatpack, No-leads (QFN) package configuration.
 - The package thermal pad must be soldered to the board for thermal and mechanical performance.
 - See the additional figure in the Product Data Sheet for details regarding the exposed thermal pad features and dimensions.
 - Falls within JEDEC MO-220.

THERMAL PAD MECHANICAL DATA

RGT (S-PVQFN-N16)

PLASTIC QUAD FLATPACK NO-LEAD

THERMAL INFORMATION

This package incorporates an exposed thermal pad that is designed to be attached directly to an external heatsink. The thermal pad must be soldered directly to the printed circuit board (PCB). After soldering, the PCB can be used as a heatsink. In addition, through the use of thermal vias, the thermal pad can be attached directly to the appropriate copper plane shown in the electrical schematic for the device, or alternatively, can be attached to a special heatsink structure designed into the PCB. This design optimizes the heat transfer from the integrated circuit (IC).

For information on the Quad Flatpack No-Lead (QFN) package and its advantages, refer to Application Report, QFN/SON PCB Attachment, Texas Instruments Literature No. SLUA271. This document is available at www.ti.com.

The exposed thermal pad dimensions for this package are shown in the following illustration.

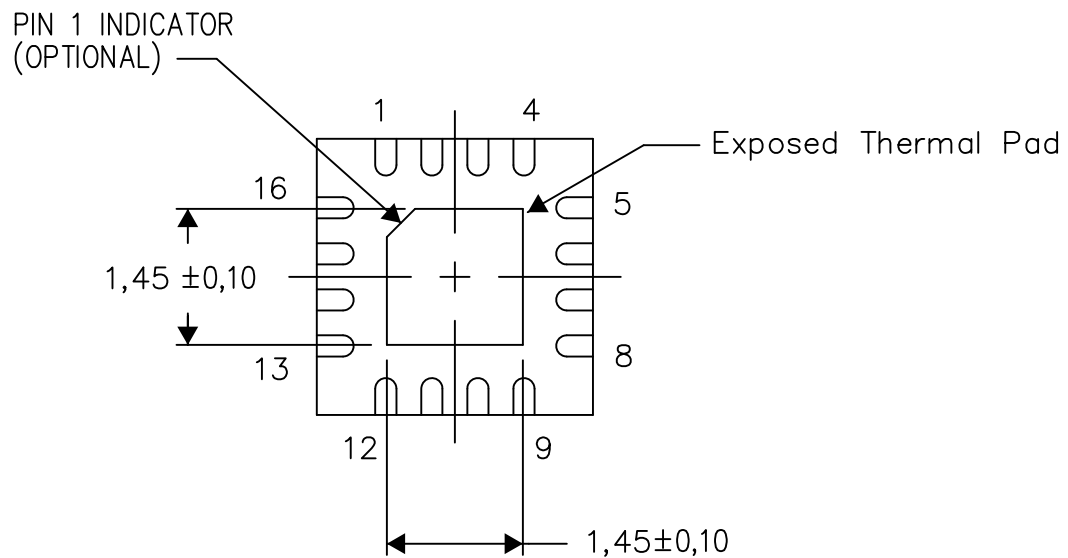

Bottom View

Exposed Thermal Pad Dimensions

4206349-2/Y 06/15

NOTE: All linear dimensions are in millimeters

RGT (S-PVQFN-N16)

PLASTIC QUAD FLATPACK NO-LEAD

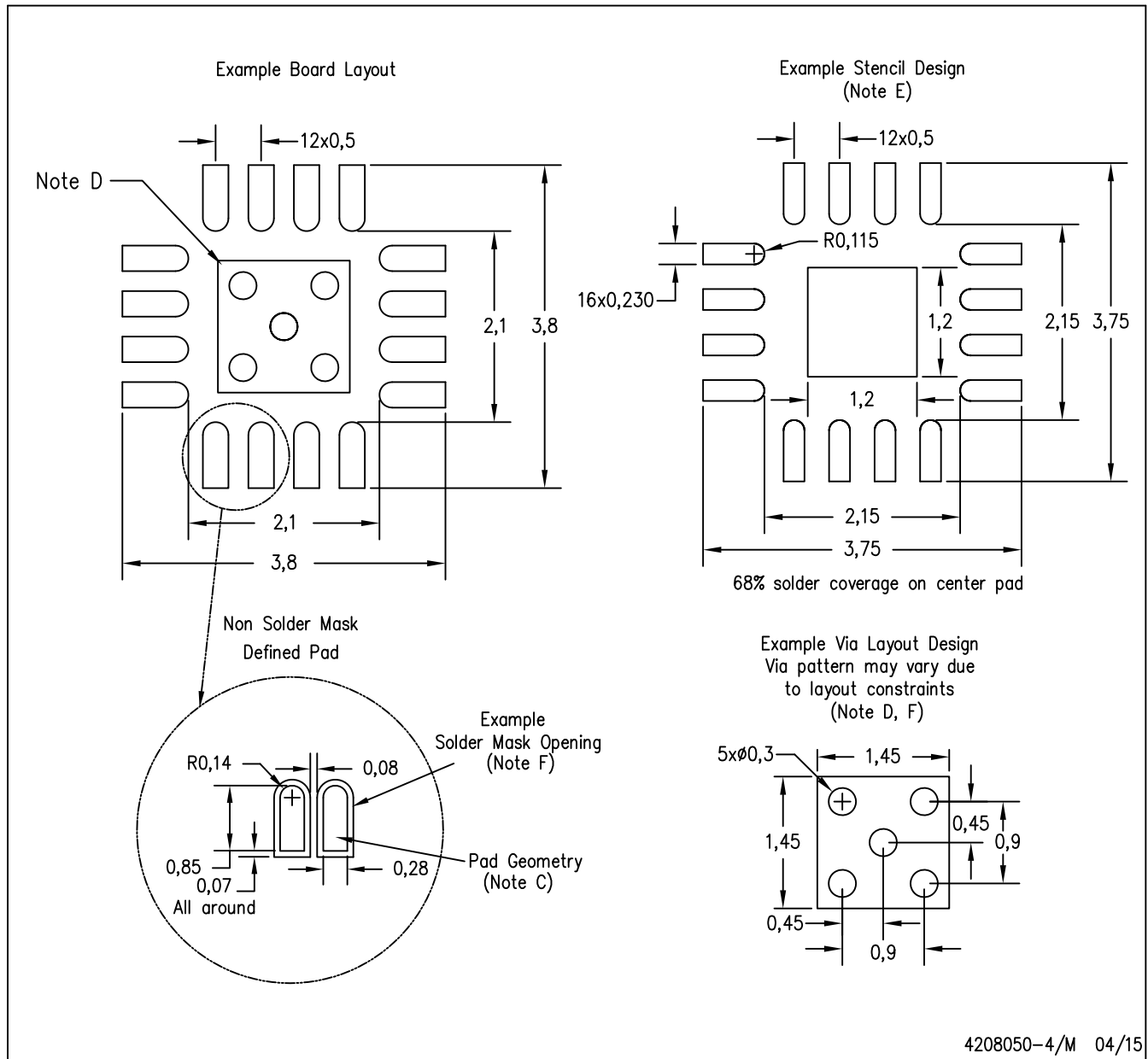

- NOTES:
- A. All linear dimensions are in millimeters.
 - B. This drawing is subject to change without notice.
 - C. Publication IPC-7351 is recommended for alternate designs.
 - D. This package is designed to be soldered to a thermal pad on the board. Refer to Application Note, QFN/SON PCB Attachment, Texas Instruments Literature No. SLUA271, and also the Product Data Sheets for specific thermal information, via requirements, and recommended board layout. These documents are available at www.ti.com <<http://www.ti.com>>.
 - E. Laser cutting apertures with trapezoidal walls and also rounding corners will offer better paste release. Customers should contact their board assembly site for stencil design recommendations. Refer to IPC 7525 for stencil design considerations.
 - F. Customers should contact their board fabrication site for minimum solder mask web tolerances between signal pads.

IMPORTANT NOTICE

Texas Instruments Incorporated and its subsidiaries (TI) reserve the right to make corrections, enhancements, improvements and other changes to its semiconductor products and services per JESD46, latest issue, and to discontinue any product or service per JESD48, latest issue. Buyers should obtain the latest relevant information before placing orders and should verify that such information is current and complete. All semiconductor products (also referred to herein as "components") are sold subject to TI's terms and conditions of sale supplied at the time of order acknowledgment.

TI warrants performance of its components to the specifications applicable at the time of sale, in accordance with the warranty in TI's terms and conditions of sale of semiconductor products. Testing and other quality control techniques are used to the extent TI deems necessary to support this warranty. Except where mandated by applicable law, testing of all parameters of each component is not necessarily performed.

TI assumes no liability for applications assistance or the design of Buyers' products. Buyers are responsible for their products and applications using TI components. To minimize the risks associated with Buyers' products and applications, Buyers should provide adequate design and operating safeguards.

TI does not warrant or represent that any license, either express or implied, is granted under any patent right, copyright, mask work right, or other intellectual property right relating to any combination, machine, or process in which TI components or services are used. Information published by TI regarding third-party products or services does not constitute a license to use such products or services or a warranty or endorsement thereof. Use of such information may require a license from a third party under the patents or other intellectual property of the third party, or a license from TI under the patents or other intellectual property of TI.

Reproduction of significant portions of TI information in TI data books or data sheets is permissible only if reproduction is without alteration and is accompanied by all associated warranties, conditions, limitations, and notices. TI is not responsible or liable for such altered documentation. Information of third parties may be subject to additional restrictions.

Resale of TI components or services with statements different from or beyond the parameters stated by TI for that component or service voids all express and any implied warranties for the associated TI component or service and is an unfair and deceptive business practice. TI is not responsible or liable for any such statements.

Buyer acknowledges and agrees that it is solely responsible for compliance with all legal, regulatory and safety-related requirements concerning its products, and any use of TI components in its applications, notwithstanding any applications-related information or support that may be provided by TI. Buyer represents and agrees that it has all the necessary expertise to create and implement safeguards which anticipate dangerous consequences of failures, monitor failures and their consequences, lessen the likelihood of failures that might cause harm and take appropriate remedial actions. Buyer will fully indemnify TI and its representatives against any damages arising out of the use of any TI components in safety-critical applications.

In some cases, TI components may be promoted specifically to facilitate safety-related applications. With such components, TI's goal is to help enable customers to design and create their own end-product solutions that meet applicable functional safety standards and requirements. Nonetheless, such components are subject to these terms.

No TI components are authorized for use in FDA Class III (or similar life-critical medical equipment) unless authorized officers of the parties have executed a special agreement specifically governing such use.

Only those TI components which TI has specifically designated as military grade or "enhanced plastic" are designed and intended for use in military/aerospace applications or environments. Buyer acknowledges and agrees that any military or aerospace use of TI components which have **not** been so designated is solely at the Buyer's risk, and that Buyer is solely responsible for compliance with all legal and regulatory requirements in connection with such use.

TI has specifically designated certain components as meeting ISO/TS16949 requirements, mainly for automotive use. In any case of use of non-designated products, TI will not be responsible for any failure to meet ISO/TS16949.

Products

Audio	www.ti.com/audio
Amplifiers	amplifier.ti.com
Data Converters	dataconverter.ti.com
DLP® Products	www.dlp.com
DSP	dsp.ti.com
Clocks and Timers	www.ti.com/clocks
Interface	interface.ti.com
Logic	logic.ti.com
Power Mgmt	power.ti.com
Microcontrollers	microcontroller.ti.com
RFID	www.ti-rfid.com
OMAP Applications Processors	www.ti.com/omap
Wireless Connectivity	www.ti.com/wirelessconnectivity

Applications

Automotive and Transportation	www.ti.com/automotive
Communications and Telecom	www.ti.com/communications
Computers and Peripherals	www.ti.com/computers
Consumer Electronics	www.ti.com/consumer-apps
Energy and Lighting	www.ti.com/energy
Industrial	www.ti.com/industrial
Medical	www.ti.com/medical
Security	www.ti.com/security
Space, Avionics and Defense	www.ti.com/space-avionics-defense
Video and Imaging	www.ti.com/video

TI E2E Community

e2e.ti.com