

TL4242-Q1 Adjustable LED Driver

1 Features

- Qualified for Automotive Applications
- AEC-Q100 Test Guidance With the Following Results:
 - Device Temperature Grade 2: –40°C to 105°C Ambient Operating Temperature Range for QFN package
 - Device Temperature Grade 1: –40°C to 125°C Ambient Operating Temperature Range for SFM package
 - Device HBM ESD Classification Level H1C
 - Device CDM ESD Classification Level C3B
- Adjustable Constant Current up to 500 mA ($\pm 5\%$)
- Wide Input-Voltage Range up to 42 V
- Low Dropout Voltage
- Open-Load Detection
- Overtemperature Protection
- Short-Circuit Proof
- Reverse-Polarity Proof

2 Applications

Automotive LED Lighting Applications Including:

- Rear Light
- Daytime Running Light
- Fog Light
- Position Light
- Interior Light
- Stop or Tail Light

3 Description

The TL4242-Q1 is an integrated adjustable constant-current source, driving loads up to 500 mA. One can adjust the output current level through an external resistor. The device design is for supplying high-power LEDs (for example, OSRAM Dragon LA W57B) under the severe conditions of automotive applications, resulting in constant brightness and extended LED lifetime. The device comes in the DRJ (QFN) package. Protection circuits prevent damage to the device in case of overload, short-circuit, reverse polarity, and overheat. The device provides the connected LEDs protection against reverse polarity as well as excess voltages up to 45 V.

The integrated PWM input of the TL4242-Q1 permits LED brightness regulation by pulse-width modulation (PWM). The high-input impedance of the PWM input allows operating the LED driver as a protected high-side switch.

Device Information⁽¹⁾

PART NUMBER	PACKAGE	BODY SIZE (NOM)
TL4242-Q1	TO-263 (7)	10.00 mm x 9.25 mm
	WSO8 (8)	4.00 mm x 4.00 mm

(1) For all available packages, see the orderable addendum at the end of the data sheet.

Typical Application Schematic

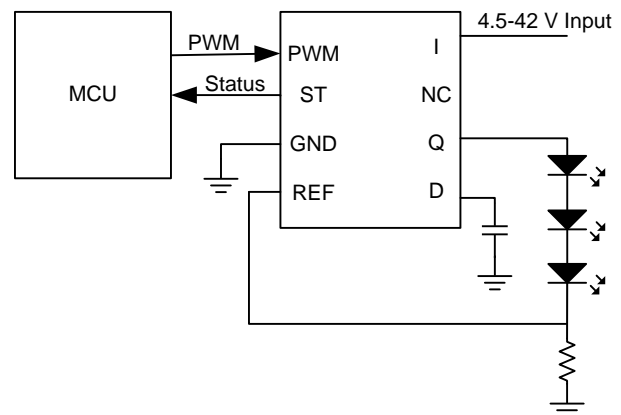

Table of Contents

1 Features	1	7.3 Feature Description	7
2 Applications	1	7.4 Device Functional Modes	8
3 Description	1	8 Application and Implementation	9
4 Revision History	2	8.1 Application Information	9
5 Pin Configuration and Functions	3	8.2 Typical Applications	9
6 Specifications	4	9 Power Supply Recommendations	13
6.1 Absolute Maximum Ratings	4	10 Layout	13
6.2 ESD Ratings	4	10.1 Layout Guidelines	13
6.3 Recommended Operating Conditions	4	10.2 Layout Example	13
6.4 Thermal Information	4	10.3 Thermal Considerations	13
6.5 Electrical Characteristics	5	11 Device and Documentation Support	14
6.6 Typical Characteristics	6	11.1 Trademarks	14
7 Detailed Description	7	11.2 Electrostatic Discharge Caution	14
7.1 Overview	7	11.3 Glossary	14
7.2 Functional Block Diagram	7	12 Mechanical, Packaging, and Orderable Information	14

4 Revision History

Changes from Revision E (July 2013) to Revision F	Page
<ul style="list-style-type: none"> Added <i>Pin Configuration and Functions</i> section, <i>ESD Ratings</i> table, <i>Feature Description</i> section, <i>Device Functional Modes</i>, <i>Application and Implementation</i> section, <i>Power Supply Recommendations</i> section, <i>Layout</i> section, <i>Device and Documentation Support</i> section, and <i>Mechanical, Packaging, and Orderable Information</i> section 	1
<hr/>	
Changes from Revision D (May 2013) to Revision E	Page
<ul style="list-style-type: none"> Added new graph to Typical Characteristics 	6
<hr/>	
Changes from Revision C (October 2012) to Revision D	Page
<ul style="list-style-type: none"> Changed minimum storage temperature to –55°C 	4
<hr/>	
Changes from Revision B (September 2012) to Revision C	Page
<ul style="list-style-type: none"> Added Stoplight and Taillight Application section Added Thermal Considerations section Added PCB Design Guideline section 	11 13 13
<hr/>	
Changes from Revision A (August, 2012) to Revision B	Page
<ul style="list-style-type: none"> Manually appended mechanical data, thermal pad data, and package option addendum 	10

5 Pin Configuration and Functions

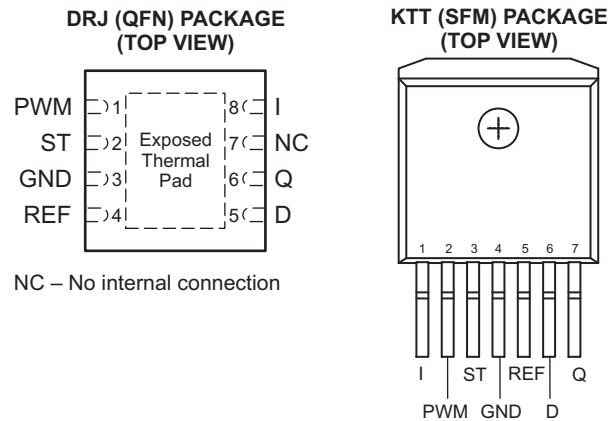

Pin Functions

NAME	PIN		I/O	DESCRIPTION
	NUMBER			
	DRJ	KTT		
D	5	6	I	Status delay. To set status reaction delay, connect to GND with a capacitor. For no delay, leave open.
GND	3	4	–	Ground
I	8	1	I	Input. Connect directly to GND as close as possible to the device with a 100-nF ceramic capacitor.
NC	7	N/A	–	No internal connection
PWM	1	2	I	Pulse-width modulation input. If not used, connect to I.
Q	6	7	O	Output
REF	4	5	I	Reference input. Connect to a shunt resistor.
ST	2	3	O	Status output. Open-collector output. Connect to an external pullup resistor ($R_{PULLUP} \geq 4.7 \text{ k}\Omega$).
Thermal pad	–	–	–	Solder the thermal pad directly to the PCB. Connect to ground or leave floating

6 Specifications

6.1 Absolute Maximum Ratings

over operating free-air temperature range (unless otherwise noted)⁽¹⁾

		MIN	MAX	UNIT
Supply voltage ⁽²⁾ , V_{CC}		-42	45	V
Input voltage, V_I	D	-0.3	7	V
	PWM	-40	40	V
	REF	-1	16	V
Output voltage, V_O	Q	-1	41	V
	ST	-0.3	40	V
Output current, I_O	PWM		±1	mA
	REF		±2	mA
	ST		±5	mA
Virtual-junction temperature, T_J		-40	150	°C
Storage temperature, T_{stg}		-55	150	

- (1) Stresses beyond those listed under *Absolute Maximum Ratings* may cause permanent damage to the device. These are stress ratings only, and functional operation of the device at these or any other conditions beyond those indicated under *Recommended Operating Conditions* is not implied. Exposure to absolute-maximum-rated conditions for extended periods may affect device reliability.
- (2) All voltage values are with respect to the network ground terminal.

6.2 ESD Ratings

			VALUE	UNIT	
$V_{(ESD)}$	Electrostatic discharge	Human body model (HBM), per AEC Q100-002 ⁽¹⁾	±1500	V	
		Charged device model (CDM), per AEC Q100-011	Corner pins (1, 4, 5, and 8)		±1000
			Other pins		±1000
		Machine model (MM) AEC-Q100 Classification Level M3	±200		

- (1) AEC Q100-002 indicates HBM stressing is done in accordance with the ANSI/ESDA/JEDEC JS-001 specification.

6.3 Recommended Operating Conditions

		MIN	MAX	UNIT
V_{CC}	Supply voltage	4.5	42	V
V_{ST}	Status (ST) output voltage		16	V
V_{PWM}	PWM voltage	0	40	V
C_D	Status delay (D) capacitance	0	2.2	µF
R_{REF}	Reference (REF) resistor	0	10	Ω
T_A	Operating free-air temperature, QFN	-40	105	°C
T_A	Operating free-air temperature, SFM	-40	125	°C

6.4 Thermal Information

THERMAL METRIC ⁽¹⁾		TL4242-Q1		UNIT
		DRJ	KTT	
		8 PINS	7 PINS	
$R_{\theta JA}$	Junction-to-ambient thermal resistance	39	31.6	°C/W
$R_{\theta Jctop}$	Junction-to-case (top) thermal resistance	31.5	34.7	
$R_{\theta JB}$	Junction-to-board thermal resistance	15.5	8.2	
ψ_{JT}	Junction-to-top characterization parameter	0.3	0.7	
ψ_{JB}	Junction-to-board characterization parameter	15.6	8.2	
$R_{\theta Jcbot}$	Junction-to-case (bottom) thermal resistance	1.8	0.7	

- (1) For more information about traditional and new thermal metrics, see the *IC Package Thermal Metrics* application report, SPRA953.

6.5 Electrical Characteristics

over recommended operating free-air temperature range, $V_I = 13.5\text{ V}$, $R_{REF} = 0.47\ \Omega$, $V_{PWM,H}$, $T_A = -40^\circ\text{C}$ to 105°C (QFN), $T_A = -40^\circ\text{C}$ to 125°C (SFM), all voltages with respect to ground (unless otherwise noted)

PARAMETER		TEST CONDITIONS	MIN	TYP	MAX	UNIT
OVERALL DEVICE						
I_{QL}	Supply current	$V_Q = 6.6\text{ V}$		12	22	mA
I_{QOFF}	Supply current, off mode	PWM = L, $T_J < 85^\circ\text{C}$		0.1	2	μA
OUTPUT						
I_Q	Output current	$V_Q - V_{REF}^{(1)} = 6.6\text{ V}$	357	376	395	mA
		$V_Q - V_{REF} = 6.6\text{ V}$, $R_{REF} = 1\ \Omega$	168	177	185	
		$V_Q - V_{REF} = 6.6\text{ V}$, $R_{REF} = 0.39\ \Omega$	431	454	476	
		$V_Q - V_{REF} = 5.4\text{ V}$ to 7.8 V , $V_I = 9\text{ V}$ to 16 V	357	376	395	
I_{Qmax}	Output current limit	$R_{REF} = 0\ \Omega$		600		mA
V_{dr}	Drop voltage	$I_Q = 300\text{ mA}$		0.35	0.7	V
PWM INPUT						
$V_{PWM,H}$	High-level PWM voltage		2.6			V
$V_{PWM,L}$	Low-level PWM voltage				0.7	V
$I_{PWM,H}$	High-level PWM input current	$V_{PWM} = 5\text{ V}$		220	500	μA
$I_{PWM,L}$	Low-level PWM input current	$V_{PWM} = 0\text{ V}$	-1		1	μA
$t_{PWM,ON}$	Delay time, turnon	70% of I_{Qnom} , see Figure 7	0	15	40	μs
$t_{PWM,OFF}$	Delay time, turnoff	30% of I_{Qnom} , see Figure 7	0	15	40	μs
REFERENCE (REF)						
V_{REF}	Reference voltage	$R_{REF} = 0.39\ \Omega$ to $1\ \Omega$	168	177	185	mV
I_{REF}	Reference input current	$V_{REF} = 180\text{ mV}$	-1	0.1	1	μA
STATUS OUTPUT (ST)						
V_{IQL}	Lower status-switching threshold	ST = L	15	25		mV
V_{IQH}	Upper status-switching threshold	ST = H		30	40	mV
V_{STL}	Low-level status voltage	$I_{ST} = 1.5\text{ mA}$			0.4	V
I_{STLK}	Leakage current	$V_{ST} = 5\text{ V}$			5	μA
STATUS DELAY (D)						
t_{STHL}	Delay time, status reaction	$C_D = 47\text{ nF}$, ST H→L	6	10	14	ms
t_{STLH}	Delay time, status release	$C_D = 47\text{ nF}$, ST L→H		10	20	μs

(1) $V_Q - V_{REF}$ equals the forward voltage sum of the connected LEDs (see [Typical Application Schematic](#)).

6.6 Typical Characteristics

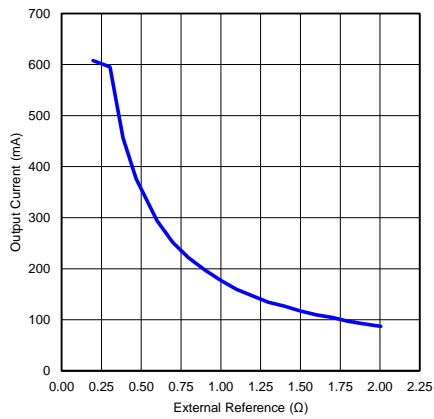

Figure 1. Output Current vs External Resistance

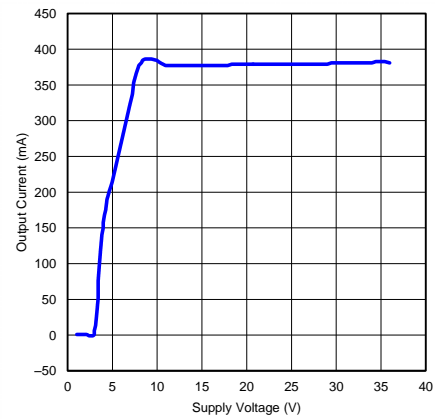

Figure 2. Output Current vs Supply Voltage

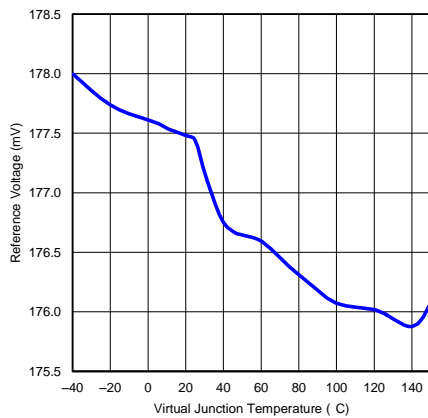

Figure 3. Reference Voltage vs Junction Temperature

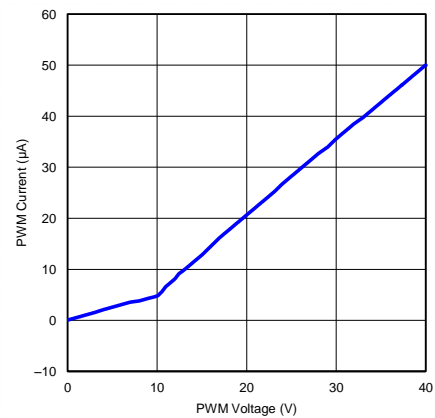

Figure 4. PWM Pin Input Current vs PWM Voltage

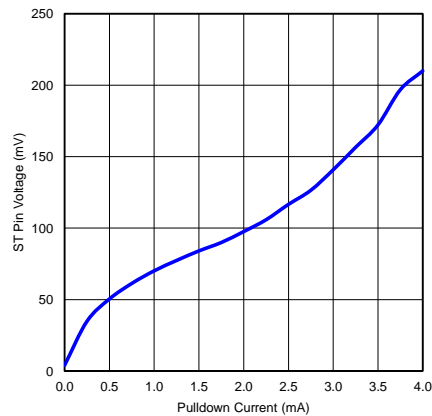

Figure 5. ST Pin Voltage vs ST Pin Pulldown Current

7 Detailed Description

7.1 Overview

The TL4242-Q1 is an integrated adjustable constant-current source, driving loads up to 500 mA. The current can be set by an external resistor. And the load current can be modulated by a PWM input. TL4242-Q1 integrates protections such as open load, overtemperature, and reverse polarity.

7.2 Functional Block Diagram

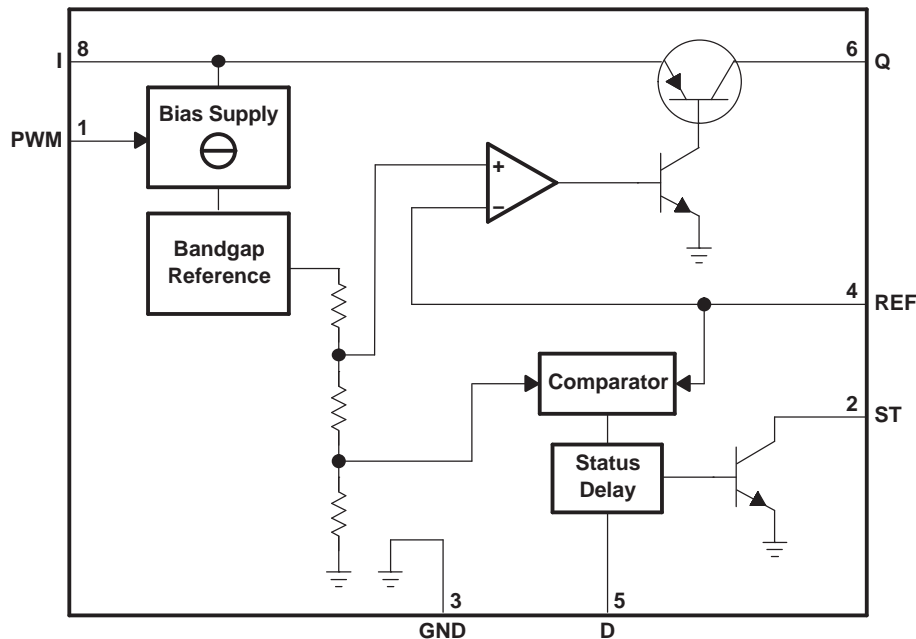

7.3 Feature Description

The TL4242-Q1 is an integrated adjustable constant-current source driving loads up to 500 mA. TL4242-Q1 is qualified for automotive applications. The output current level can be adjusted via an external resistor. Protection circuits prevent damage to the device in case of overload, short-circuit, reverse polarity, and overheat. The connected LEDs are protected against reverse polarity as well as over voltages up to 45 V. The integrated PWM input of the TL4242-Q1 permits LED brightness regulation by pulse-width modulation. Due to the high input impedance of the PWM input, the LED driver can be operated as a protected high-side switch.

The external shunt resistor in the ground path of the connected LEDs senses the LED current. A regulation loop holds the voltage drop at the shunt resistor at a constant level of 177 mV (typical). The selection of the shunt resistance, R_{REF} , sets the constant-current level. Calculate the typical output current using [Equation 1](#):

$$I_{Q,typ} = \frac{V_{REF}}{R_{REF}} \quad (1)$$

where V_{REF} is the reference voltage (typically 177 mV) (see [Electrical Characteristics](#)). The equation applies for $R_{REF} = 0.39 \Omega$ to 10Ω .

The output current is shown as a function of the reference resistance in [Equation 1](#). With the PWM input, one can regulate the LED brightness through the duty cycle. Also, PWM = L sets the TL4242-Q1 in sleep mode, resulting in a very low current consumption of $< 1 \mu A$ (typical). The high impedance of the PWM input (see [Figure 4](#)) permits the use of the PWM pin as an enable input.

7.4 Device Functional Modes

7.4.1 Pulse-Width Modulation (PWM)

In general applications, PWM can be used to control TL4242 as a high-side driver. High level enables the device. Low level disables the device. In LED lighting, PWM input provides a convenient way to control the brightness of the LED load. Due to the high-input impedance of the PWM input, the LED driver can be operated as a protected high-side switch.

7.4.2 Status Output (ST)

Open-collector output. Connect to an external pullup resistor ($R_{PULLUP} \geq 4.7 \text{ k}\Omega$). It provides information of open load, overtemperature protection.

7.4.3 Reference (REF)

REF is used to set load current. In applications, the load current is sensed by a resistor in series with the load. The voltage on the REF pin is regulated at 177 mV during normal operation. Therefore, the current of the load is determined by V_{REF}/R_{SENSE} .

8 Application and Implementation

NOTE

Information in the following applications sections is not part of the TI component specification, and TI does not warrant its accuracy or completeness. TI's customers are responsible for determining suitability of components for their purposes. Customers should validate and test their design implementation to confirm system functionality.

8.1 Application Information

The TL4242-Q1 is usually used in the automotive lighting applications. A microcontroller is usually used to generate PWM waveform to dimming the LED.

8.2 Typical Applications

8.2.1 Application Circuit

Figure 6 shows a typical application with the TL4242-Q1 LED driver. A supply current adjusted by the R_{REF} resistor drives the three LEDs, preventing brightness variations due to forward voltage spread of the LEDs. An appropriate duty cycle applied to the PWM pin can compensate through software for the luminosity spread arising from the LED production process. Therefore, it is not necessary to select LEDs for forward voltage or luminosity classes. The minimum supply voltage calculates the sum of the LED forward voltages, the TL4242-Q1 drop voltage (maximum 0.7 V at an LED current of 300 mA), and the maximum voltage drop at the shunt resistor R_{REF} of 185 mV.

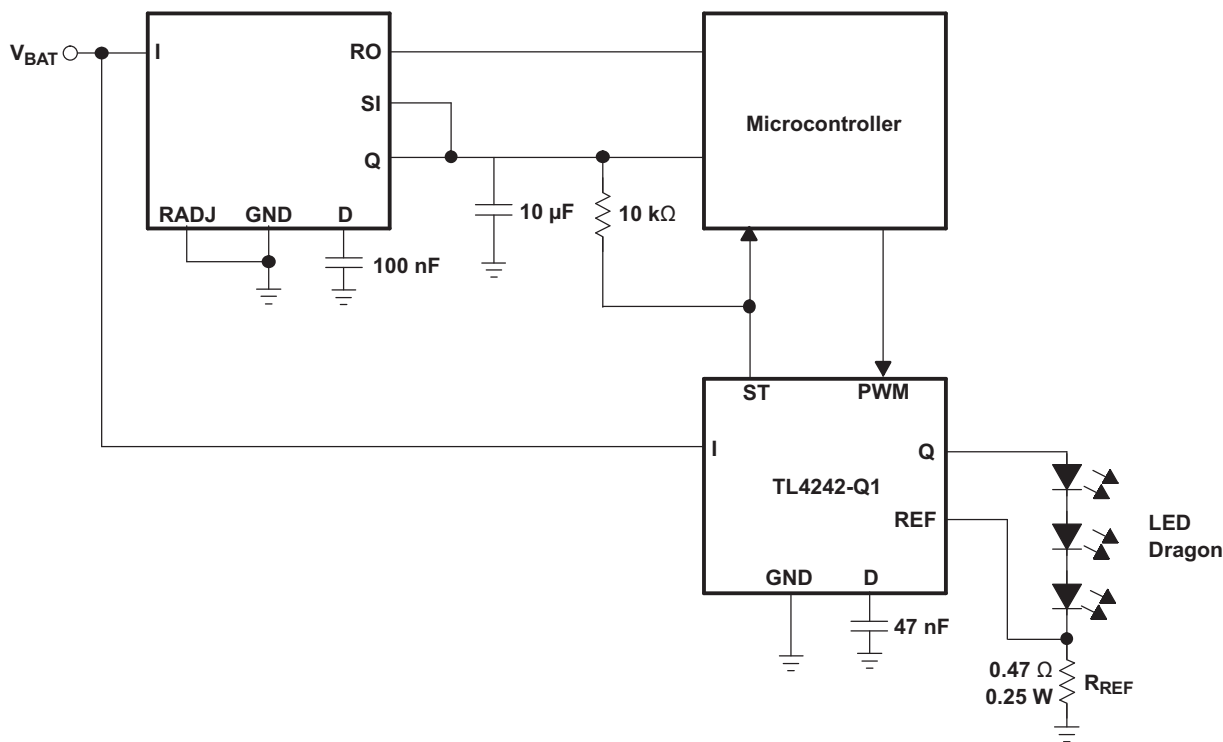

Figure 6. Application Circuit

8.2.1.1 Design Requirements

DESIGN PARAMETER	EXAMPLE VALUE
R_{REF}	0.47 Ω

8.2.1.2 Detailed Design Procedure

The status output of the LED driver (ST) detects an open-load condition, enabling supervision of correct LED operation. A voltage drop at the shunt resistor (R_{REF}) below 25 mV (typical) detects an LED failure. In this case, the status output pin (ST) goes low after a delay time adjustable by an optional capacitor connected to pin D.

Figure 7 shows the functionality and timing of ST and PWM. One can adjust the status delay through the capacitor connected to pin D. Delay time scales linearly with the capacitance, C_D :

$$t_{STHL,typ} = \frac{C_D}{47 \text{ nF}} \times 10 \text{ ms}$$

$$t_{STHL,typ} = \frac{C_D}{47 \text{ nF}} \times 10 \text{ }\mu\text{s}$$

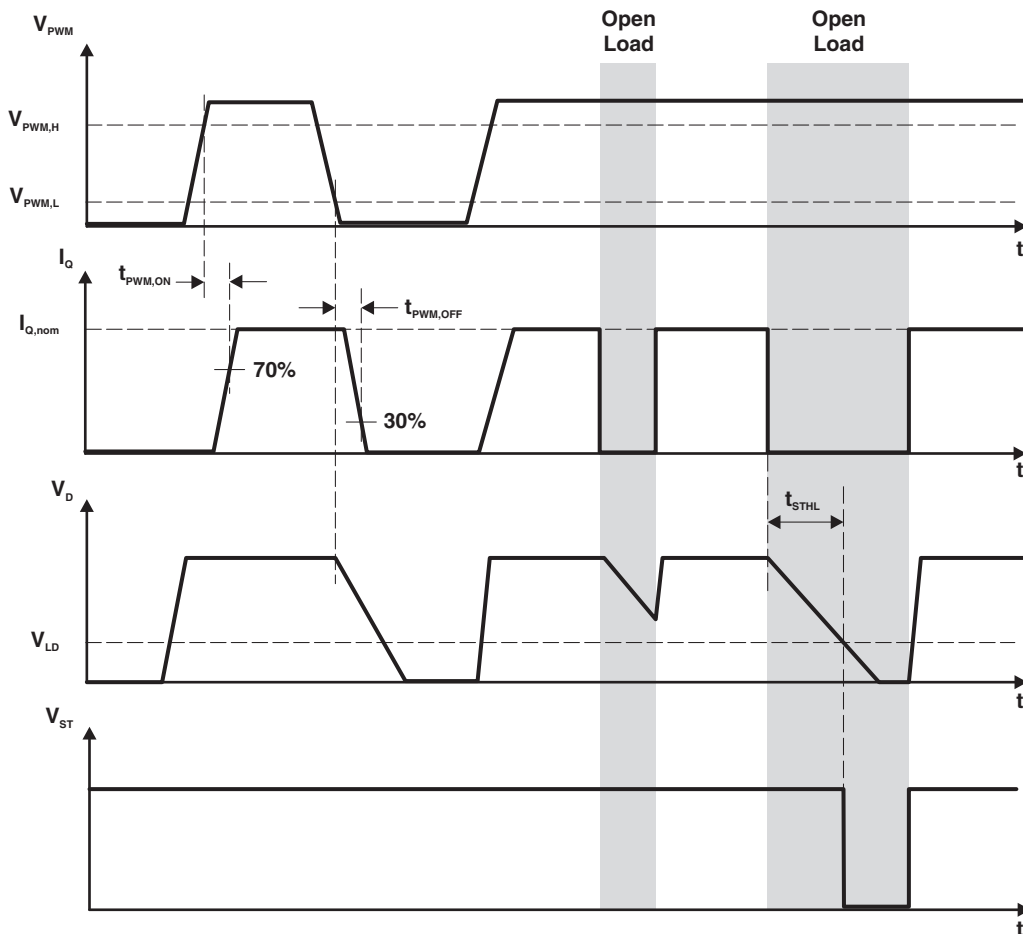

Figure 7. Function and Timing Diagram

8.2.1.3 Application Curves

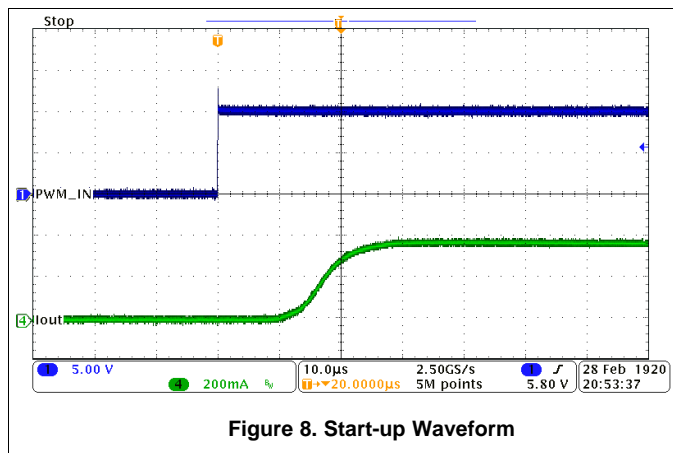

Figure 8. Start-up Waveform

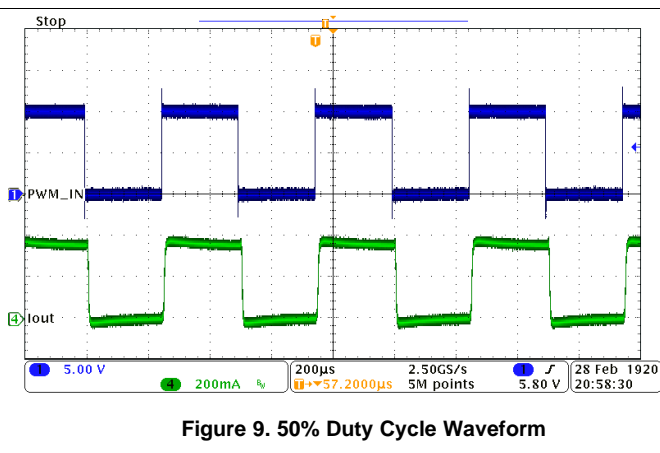

Figure 9. 50% Duty Cycle Waveform

8.2.2 Stoplight and Taillight Application

For many automobiles, the same set of LEDs illuminates both taillights and stoplights. Thus, the LEDs must operate at two different brightness levels, full brightness for the stoplight and 10% to 25% brightness for the taillight. The easiest way to achieve the different brightness is dimming by pulse-width modulation (PWM), which holds the color spectrum of the LED over its whole brightness range. The maximum current that passes through the LED is programmable by sense resistor R_{REF} .

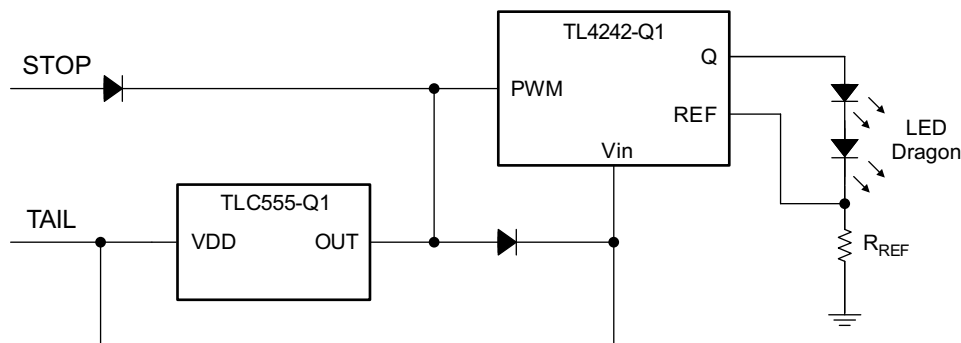

Figure 10. Stoplight and Taillight Application Circuit

8.2.2.1 Design Requirements

DESIGN PARAMETER	EXAMPLE VALUE
R_{REF}	1 Ω

8.2.2.2 Detailed Design Procedure

Obtain the maximum current, I_{Qmax} , that passes through the LEDs by Equation 2:

$$I_{Qmax} = \frac{V_{REF}}{R_{REF}} \tag{2}$$

For example, if R_{REF} equals 1 Ω , as V_{REF} is a fixed value range from 168 mV to 185 mV, I_{Qmax} should be 168 mA to 185 mA.

Figure 10 shows the application circuit of the stoplight and taillight including an automotive-qualified timer, TLC555-Q1, the duty cycle of which is programmable by two external resistors. One can see that driving the STOP signal high pulls the PWM pin constantly high, creating 100% duty cycle. Thus the LEDs operate at full brightness. When the TAIL signal is high, the LEDs operate at 25% brightness because the TLC555-Q1 timer is programmed at a fixed duty cycle of 25%.

8.2.2.3 Application Curves

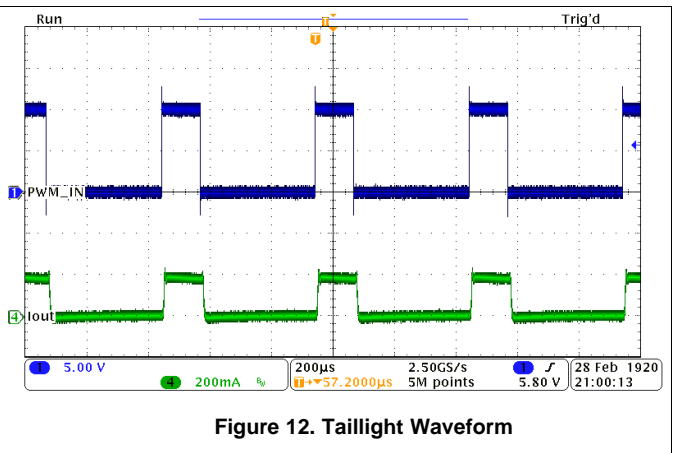
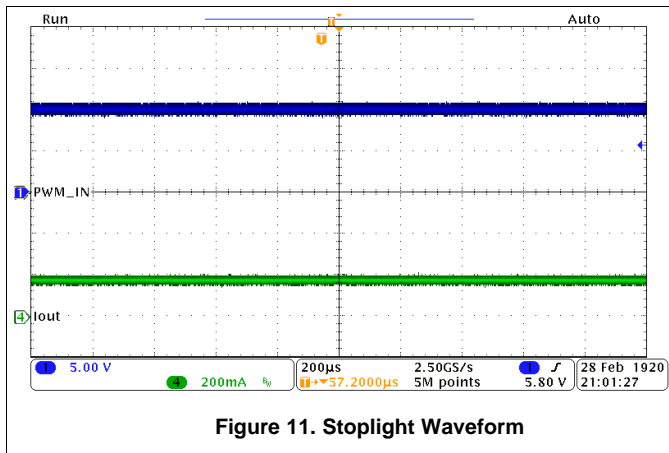

9 Power Supply Recommendations

It is recommended to put a 4.7-μF ceramic capacitor on the input pin. Also a 0.1-μF bypass capacitor can be put at input pin for noise filtering. Input voltage should be between 4.5 V and 42 V.

10 Layout

10.1 Layout Guidelines

In order to prevent thermal shutdown, T_J must be less than 150°C. If the input voltage is very high, the power dissipation might be large. Currently there is the KTT (DDPAK) package which has good thermal impedance, but at the same time, the PCB layout is also very important. Good PCB design can optimize heat transfer, which is absolutely essential for the long-term reliability of the device.

- Maximize the copper coverage on the PCB to increase the thermal conductivity of the board, because the major heat-flow path from the package to the ambient is through the copper on the PCB. Maximum copper is extremely important when there are not any heat sinks attached to the PCB on the other side of the package.
- Add as many thermal vias as possible directly under the package ground pad to optimize the thermal conductivity of the board.
- All thermal vias should be either plated shut or plugged and capped on both sides of the board to prevent solder voids. To ensure reliability and performance, the solder coverage should be at least 85 percent.

10.2 Layout Example

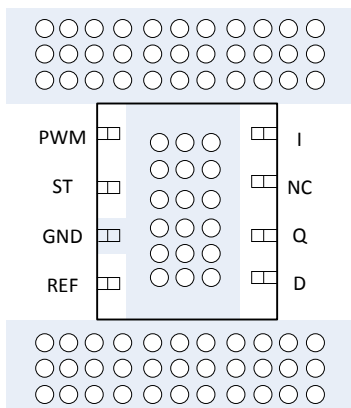

Figure 13. TL4242-Q1 Board Layout Diagram

10.3 Thermal Considerations

This device operates a thermal shutdown (TSD) circuit as a protection from overheating. For continuous normal operation, the junction temperature should not exceed the thermal-shutdown trip point. If the junction temperature exceeds the thermal-shutdown trip point, the output turns off. When the junction temperature falls below the thermal-shutdown trip point, the output turns on again.

Calculate the power dissipated by the device according to [Equation 3](#):

$$P = (V_I - V_O) \times I_O + V_I \times I_Q \quad (3)$$

In the formula, V_I represents the input voltage of the device, V_O stands for the output voltage, and I_O means the output current of LED and I_Q is the quiescent current dissipated by the device. The very small value of I_Q sometimes allows one to neglect it.

After determining the power dissipated by the device, calculate the junction temperature from the ambient temperature and the device thermal impedance.

$$T_J = T_A + R_{\theta JA} \times P$$

11 Device and Documentation Support

11.1 Trademarks

All trademarks are the property of their respective owners.

11.2 Electrostatic Discharge Caution



These devices have limited built-in ESD protection. The leads should be shorted together or the device placed in conductive foam during storage or handling to prevent electrostatic damage to the MOS gates.

11.3 Glossary

[SLYZ022](#) — *TI Glossary*.

This glossary lists and explains terms, acronyms, and definitions.

12 Mechanical, Packaging, and Orderable Information

The following pages include mechanical, packaging, and orderable information. This information is the most current data available for the designated devices. This data is subject to change without notice and revision of this document. For browser-based versions of this data sheet, refer to the left-hand navigation.

PACKAGING INFORMATION

Orderable Device	Status (1)	Package Type	Package Drawing	Pins	Package Qty	Eco Plan (2)	Lead/Ball Finish (6)	MSL Peak Temp (3)	Op Temp (°C)	Device Marking (4/5)	Samples
TL4242QKTRQ1	ACTIVE	DDPAK/ TO-263	KTT	7	500	Green (RoHS & no Sb/Br)	CU SN	Level-3-245C-168 HR	-40 to 125	TL4242Q	Samples
TL4242TDRJRQ1	ACTIVE	SON	DRJ	8	1000	Green (RoHS & no Sb/Br)	CU NIPDAU	Level-3-260C-168 HR	-40 to 105	4242T	Samples

(1) The marketing status values are defined as follows:

ACTIVE: Product device recommended for new designs.

LIFEBUY: TI has announced that the device will be discontinued, and a lifetime-buy period is in effect.

NRND: Not recommended for new designs. Device is in production to support existing customers, but TI does not recommend using this part in a new design.

PREVIEW: Device has been announced but is not in production. Samples may or may not be available.

OBSELETE: TI has discontinued the production of the device.

(2) Eco Plan - The planned eco-friendly classification: Pb-Free (RoHS), Pb-Free (RoHS Exempt), or Green (RoHS & no Sb/Br) - please check <http://www.ti.com/productcontent> for the latest availability information and additional product content details.

TBD: The Pb-Free/Green conversion plan has not been defined.

Pb-Free (RoHS): TI's terms "Lead-Free" or "Pb-Free" mean semiconductor products that are compatible with the current RoHS requirements for all 6 substances, including the requirement that lead not exceed 0.1% by weight in homogeneous materials. Where designed to be soldered at high temperatures, TI Pb-Free products are suitable for use in specified lead-free processes.

Pb-Free (RoHS Exempt): This component has a RoHS exemption for either 1) lead-based flip-chip solder bumps used between the die and package, or 2) lead-based die adhesive used between the die and leadframe. The component is otherwise considered Pb-Free (RoHS compatible) as defined above.

Green (RoHS & no Sb/Br): TI defines "Green" to mean Pb-Free (RoHS compatible), and free of Bromine (Br) and Antimony (Sb) based flame retardants (Br or Sb do not exceed 0.1% by weight in homogeneous material)

(3) MSL, Peak Temp. - The Moisture Sensitivity Level rating according to the JEDEC industry standard classifications, and peak solder temperature.

(4) There may be additional marking, which relates to the logo, the lot trace code information, or the environmental category on the device.

(5) Multiple Device Markings will be inside parentheses. Only one Device Marking contained in parentheses and separated by a "~" will appear on a device. If a line is indented then it is a continuation of the previous line and the two combined represent the entire Device Marking for that device.

(6) Lead/Ball Finish - Orderable Devices may have multiple material finish options. Finish options are separated by a vertical ruled line. Lead/Ball Finish values may wrap to two lines if the finish value exceeds the maximum column width.

Important Information and Disclaimer: The information provided on this page represents TI's knowledge and belief as of the date that it is provided. TI bases its knowledge and belief on information provided by third parties, and makes no representation or warranty as to the accuracy of such information. Efforts are underway to better integrate information from third parties. TI has taken and continues to take reasonable steps to provide representative and accurate information but may not have conducted destructive testing or chemical analysis on incoming materials and chemicals. TI and TI suppliers consider certain information to be proprietary, and thus CAS numbers and other limited information may not be available for release.

In no event shall TI's liability arising out of such information exceed the total purchase price of the TI part(s) at issue in this document sold by TI to Customer on an annual basis.

OTHER QUALIFIED VERSIONS OF TL4242-Q1 :

- Catalog: [TL4242](#)

NOTE: Qualified Version Definitions:

- Catalog - TI's standard catalog product

TAPE AND REEL INFORMATION



QUADRANT ASSIGNMENTS FOR PIN 1 ORIENTATION IN TAPE



*All dimensions are nominal

Device	Package Type	Package Drawing	Pins	SPQ	Reel Diameter (mm)	Reel Width W1 (mm)	A0 (mm)	B0 (mm)	K0 (mm)	P1 (mm)	W (mm)	Pin1 Quadrant
TL4242QKTTRQ1	DDPAK/ TO-263	KTT	7	500	330.0	24.4	10.6	15.8	4.9	16.0	24.0	Q2
TL4242TDRJRQ1	SON	DRJ	8	1000	180.0	12.4	4.25	4.25	1.15	8.0	12.0	Q2

TAPE AND REEL BOX DIMENSIONS

*All dimensions are nominal

Device	Package Type	Package Drawing	Pins	SPQ	Length (mm)	Width (mm)	Height (mm)
TL4242QKTTTRQ1	DDPAK/TO-263	KTT	7	500	340.0	340.0	38.0
TL4242TDRJRQ1	SON	DRJ	8	1000	210.0	185.0	35.0

DRJ (S-PWSON-N8)

PLASTIC SMALL OUTLINE NO-LEAD

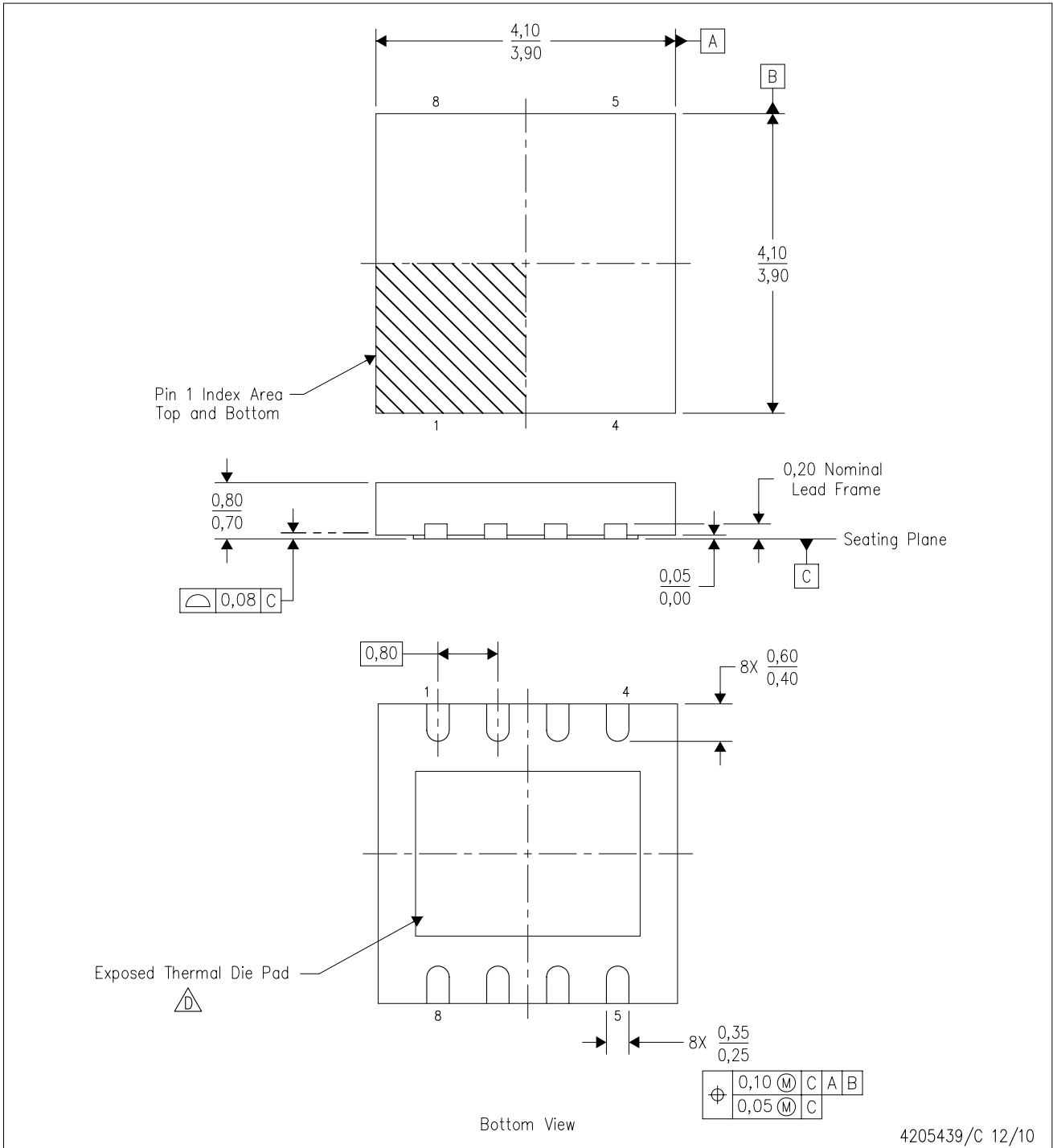

4205439/C 12/10

- NOTES:
- A. All linear dimensions are in millimeters. Dimensioning and tolerancing per ASME Y14.5M-1994.
 - B. This drawing is subject to change without notice.
 - C. SON (Small Outline No-Lead) package configuration.
 - The package thermal pad must be soldered to the board for thermal and mechanical performance. See the Product Data Sheet for details regarding the exposed thermal pad dimensions.
 - E. Package complies to JEDEC MO-229 variation WGGB.

THERMAL PAD MECHANICAL DATA

DRJ (S-PWSON-N8)

PLASTIC SMALL OUTLINE NO-LEAD

THERMAL INFORMATION

This package incorporates an exposed thermal pad that is designed to be attached directly to an external heatsink. The thermal pad must be soldered directly to the printed circuit board (PCB). After soldering, the PCB can be used as a heatsink. In addition, through the use of thermal vias, the thermal pad can be attached directly to the appropriate copper plane shown in the electrical schematic for the device, or alternatively, can be attached to a special heatsink structure designed into the PCB. This design optimizes the heat transfer from the integrated circuit (IC).

For information on the Quad Flatpack No-Lead (QFN) package and its advantages, refer to Application Report, QFN/SON PCB Attachment, Texas Instruments Literature No. SLUA271. This document is available at www.ti.com.

The exposed thermal pad dimensions for this package are shown in the following illustration.

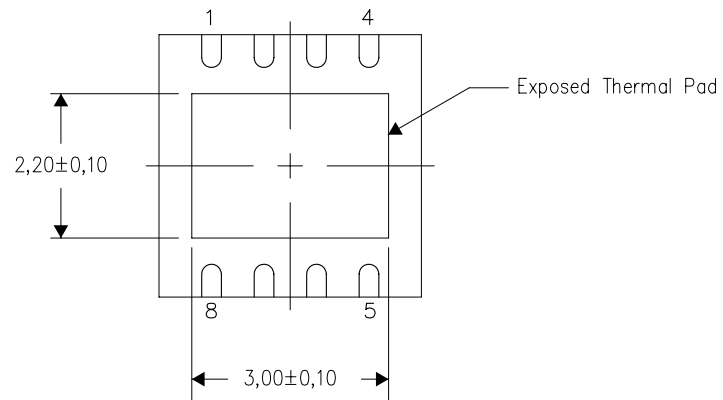

Bottom View

Exposed Thermal Pad Dimensions

4206882/F 01/11

NOTE: All linear dimensions are in millimeters

DRJ (S-PWSON-N8)

SMALL PACKAGE OUTLINE NO-LEAD

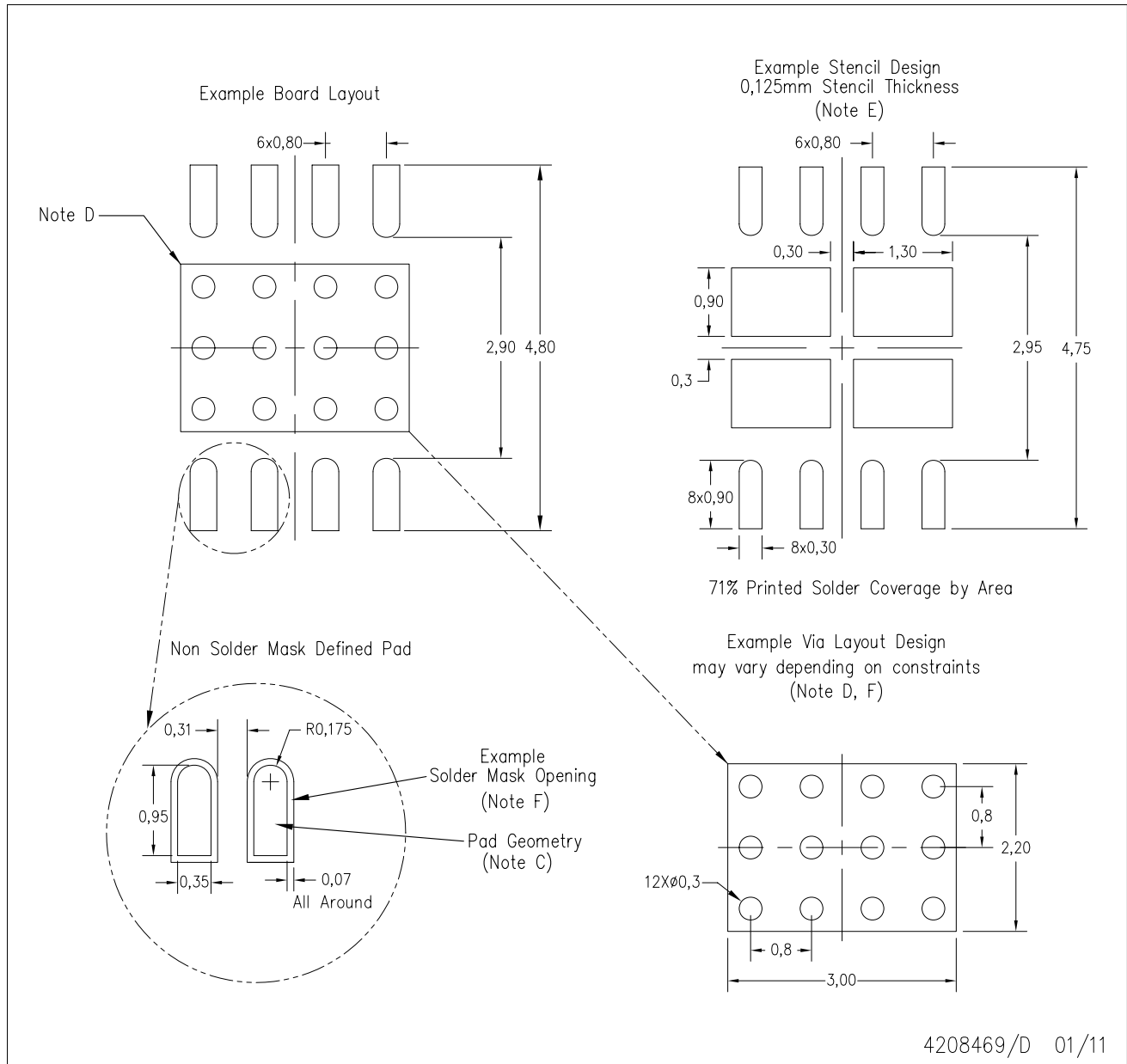

- NOTES:
- A. All linear dimensions are in millimeters.
 - B. This drawing is subject to change without notice.
 - C. Publication IPC-7351 is recommended for alternate designs.
 - D. This package is designed to be soldered to a thermal pad on the board. Refer to Application Note, Quad Flat-Pack Packages, Texas Instruments Literature No. SLUA271, and also the Product Data Sheets for specific thermal information, via requirements, and recommended board layout. These documents are available at www.ti.com <<http://www.ti.com>>.
 - E. Laser cutting apertures with electropolish and also rounding corners will offer better paste release. Customers should contact their board assembly site for stencil design recommendations. Refer to IPC 7525 for stencil design considerations.
 - F. Customers should contact their board fabrication site for solder mask tolerances and vias tenting recommendations for vias placed in the thermal pad.

KTT (R-PSFM-G7)

PLASTIC FLANGE-MOUNT PACKAGE

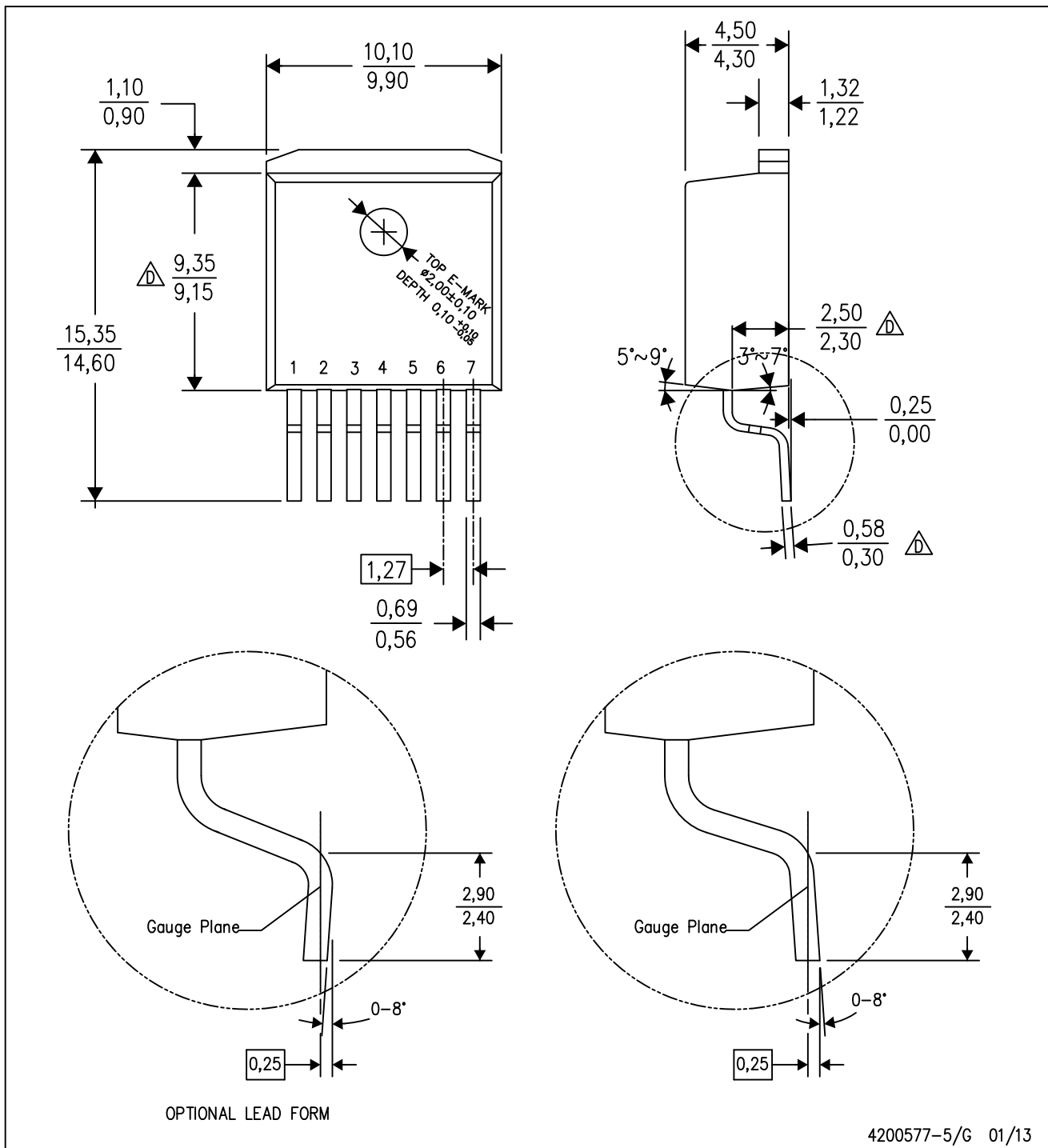

4200577-5/G 01/13

- NOTES:
- All linear dimensions are in millimeters.
 - This drawing is subject to change without notice.
 - Body dimensions do not include mold flash or protrusion. Mold flash or protrusion not to exceed 0,13 per side.
 - Falls within JEDEC TO-263 AB.

KTT (R-PSFM-G7)

PLASTIC FLANGE-MOUNT PACKAGE

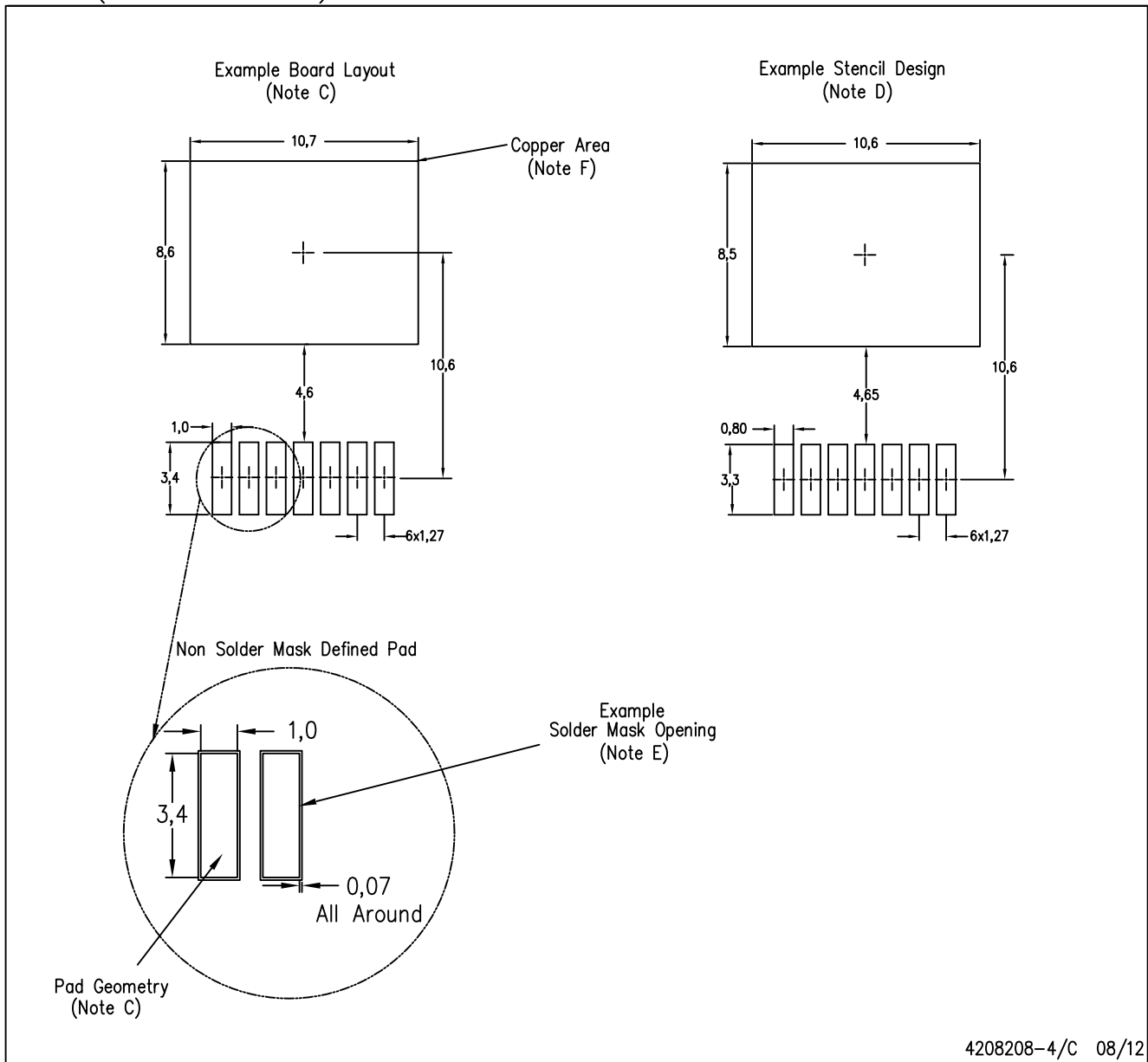

- NOTES:
- All linear dimensions are in millimeters.
 - This drawing is subject to change without notice.
 - Publication IPC-SM-782 is recommended for alternate designs.
 - Laser cutting apertures with trapezoidal walls and also rounding corners will offer better paste release. Customers should contact their board assembly site for stencil design recommendations. Refer to IPC-7525.
 - Customers should contact their board fabrication site for solder mask tolerances between and around signal pads.
 - This package is designed to be soldered to a thermal pad on the board. Refer to the Product Datasheet for specific thermal information, via requirements, and recommended thermal pad size. For thermal pad sizes larger than shown a solder mask defined pad is recommended in order to maintain the solderable pad geometry while increasing copper area.

IMPORTANT NOTICE

Texas Instruments Incorporated and its subsidiaries (TI) reserve the right to make corrections, enhancements, improvements and other changes to its semiconductor products and services per JESD46, latest issue, and to discontinue any product or service per JESD48, latest issue. Buyers should obtain the latest relevant information before placing orders and should verify that such information is current and complete. All semiconductor products (also referred to herein as "components") are sold subject to TI's terms and conditions of sale supplied at the time of order acknowledgment.

TI warrants performance of its components to the specifications applicable at the time of sale, in accordance with the warranty in TI's terms and conditions of sale of semiconductor products. Testing and other quality control techniques are used to the extent TI deems necessary to support this warranty. Except where mandated by applicable law, testing of all parameters of each component is not necessarily performed.

TI assumes no liability for applications assistance or the design of Buyers' products. Buyers are responsible for their products and applications using TI components. To minimize the risks associated with Buyers' products and applications, Buyers should provide adequate design and operating safeguards.

TI does not warrant or represent that any license, either express or implied, is granted under any patent right, copyright, mask work right, or other intellectual property right relating to any combination, machine, or process in which TI components or services are used. Information published by TI regarding third-party products or services does not constitute a license to use such products or services or a warranty or endorsement thereof. Use of such information may require a license from a third party under the patents or other intellectual property of the third party, or a license from TI under the patents or other intellectual property of TI.

Reproduction of significant portions of TI information in TI data books or data sheets is permissible only if reproduction is without alteration and is accompanied by all associated warranties, conditions, limitations, and notices. TI is not responsible or liable for such altered documentation. Information of third parties may be subject to additional restrictions.

Resale of TI components or services with statements different from or beyond the parameters stated by TI for that component or service voids all express and any implied warranties for the associated TI component or service and is an unfair and deceptive business practice. TI is not responsible or liable for any such statements.

Buyer acknowledges and agrees that it is solely responsible for compliance with all legal, regulatory and safety-related requirements concerning its products, and any use of TI components in its applications, notwithstanding any applications-related information or support that may be provided by TI. Buyer represents and agrees that it has all the necessary expertise to create and implement safeguards which anticipate dangerous consequences of failures, monitor failures and their consequences, lessen the likelihood of failures that might cause harm and take appropriate remedial actions. Buyer will fully indemnify TI and its representatives against any damages arising out of the use of any TI components in safety-critical applications.

In some cases, TI components may be promoted specifically to facilitate safety-related applications. With such components, TI's goal is to help enable customers to design and create their own end-product solutions that meet applicable functional safety standards and requirements. Nonetheless, such components are subject to these terms.

No TI components are authorized for use in FDA Class III (or similar life-critical medical equipment) unless authorized officers of the parties have executed a special agreement specifically governing such use.

Only those TI components which TI has specifically designated as military grade or "enhanced plastic" are designed and intended for use in military/aerospace applications or environments. Buyer acknowledges and agrees that any military or aerospace use of TI components which have **not** been so designated is solely at the Buyer's risk, and that Buyer is solely responsible for compliance with all legal and regulatory requirements in connection with such use.

TI has specifically designated certain components as meeting ISO/TS16949 requirements, mainly for automotive use. In any case of use of non-designated products, TI will not be responsible for any failure to meet ISO/TS16949.

Products

Audio	www.ti.com/audio
Amplifiers	amplifier.ti.com
Data Converters	dataconverter.ti.com
DLP® Products	www.dlp.com
DSP	dsp.ti.com
Clocks and Timers	www.ti.com/clocks
Interface	interface.ti.com
Logic	logic.ti.com
Power Mgmt	power.ti.com
Microcontrollers	microcontroller.ti.com
RFID	www.ti-rfid.com
OMAP Applications Processors	www.ti.com/omap
Wireless Connectivity	www.ti.com/wirelessconnectivity

Applications

Automotive and Transportation	www.ti.com/automotive
Communications and Telecom	www.ti.com/communications
Computers and Peripherals	www.ti.com/computers
Consumer Electronics	www.ti.com/consumer-apps
Energy and Lighting	www.ti.com/energy
Industrial	www.ti.com/industrial
Medical	www.ti.com/medical
Security	www.ti.com/security
Space, Avionics and Defense	www.ti.com/space-avionics-defense
Video and Imaging	www.ti.com/video

TI E2E Community

e2e.ti.com