

TLC59208F 8-Bit Fm+ I²C Bus LED Driver

1 Features

- Eight LED Drivers (Each Output Programmable at OFF, ON, Programmable LED Brightness, Programmable Group Dimming/Blinking Mixed With Individual LED Brightness)
- Eight Open-Drain Output Channels
- 256-Step (8-Bit) Linear Programmable Brightness Per LED Output Varying From Fully Off (Default) to Maximum Brightness Using a 97-kHz PWM Signal
- 256-Step Group Brightness Control Allows General Dimming [Using a 190-Hz PWM Signal From Fully Off to Maximum Brightness (Default)]
- 256-Step Group Blinking With Frequency Programmable From 24 Hz to 10.73 s and Duty Cycle From 0% to 99.6%
- 64 Programmable Slave Addresses Using Three Hardware Address Pins
- Four Software Programmable I²C Bus Addresses (One LED Group Call Address and Three LED Sub Call Addresses) Allow Groups of Devices to be Simultaneously Addressed Any Combination (For Example, One Register Used for 'All Call' so That All the TLC59208Fs on the I²C Bus Can be Simultaneously Addressed and the Second Register Used for Three Different Addresses so That One Third of All Devices on the Bus Can be Simultaneously Addressed)
- Software Enable and Disable for I²C Bus Address
- Software Reset Feature (SWRST Call) Allows the Device to be Reset Through the I²C Bus
- Up to 14 Possible Hardware Adjustable Individual I²C Bus Addresses Per Device so That Each Device Can be Programmed
- Up to 64 Possible Hardware Adjustable Individual I²C Bus Addresses Per Device so That Each Device Can be Programmed Individually
- Output State Change Programmable on the Acknowledge or the STOP Command to Update Outputs Byte-by-Byte or All at the Same Time (Default to *Change on STOP*)
- Maximum Output Current: 50 mA
- Maximum Output Voltage: 17 V
- 25-MHz Internal Oscillator Requires no External Components
- 1-MHz Fast-Mode Plus (FM+) Compatible I²C Bus Interface With 30-mA High Drive Capability on SDA Output for Driving High Capacitive Buses
- Internal Power-On Reset

- Noise Filter on SCL/SDA Inputs
- No Glitch on Power Up
- Active-Low Reset ($\overline{\text{RESET}}$)
- Supports Hot Insertion
- Low Standby Current
- 3.3-V or 5-V Supply Voltage
- 5.5-V Tolerant Inputs
- Packages Offered: 16-Pin Thin Shrink Small-Outline Package [TSSOP (PW)], 16-Pin Quad Flatpack No Lead [QFN (RGY)]
- –40°C to 85°C Operation

2 Applications

- Gaming
- Small Signage
- Industrial Equipment

3 Description

The TLC59208F is an I²C bus controlled 8-bit LED driver optimized for red/green/blue/amber (RGBA) color mixing applications. Each LED output has its own 8-bit resolution (256 steps) fixed frequency individual PWM controller that operates at 97 kHz with a duty cycle that is adjustable from 0% to 99.6% to allow the LED to be set to a specific brightness value.

Device Information⁽¹⁾

PART NUMBER	PACKAGE	BODY SIZE (NOM)
TLC59208F	TSSOP (16)	5.00 mm x 4.40 mm
	VQFN (16)	4.00 mm x 3.50 mm

(1) For all available packages, see the orderable addendum at the end of the data sheet.

Application Schematic

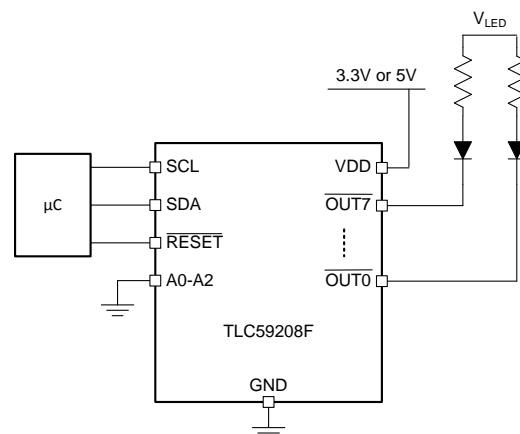

Table of Contents

1 Features 1 2 Applications 1 3 Description 1 4 Revision History 2 5 Description (continued) 3 6 Pin Configuration and Functions 3 7 Specifications 4 7.1 Absolute Maximum Ratings 4 7.2 ESD Ratings..... 4 7.3 Recommended Operating Conditions 5 7.4 Thermal Information 5 7.5 Electrical Characteristics..... 5 7.6 I ² C Interface Timing Requirements..... 6 7.7 Typical Characteristics 8 8 Parameter Measurement Information 8 9 Detailed Description 9 9.1 Overview 9 9.2 Functional Block Diagram 9	9.3 Feature Description..... 9 9.4 Device Functional Modes..... 11 9.5 Programming..... 11 9.6 Register Maps 20 10 Application and Implementation 25 10.1 Application Information..... 25 10.2 Typical Application 25 11 Power Supply Recommendations 26 12 Layout 27 12.1 Layout Guidelines 27 12.2 Layout Example 27 13 Device and Documentation Support 29 13.1 Trademarks 29 13.2 Community Resources..... 29 13.3 Electrostatic Discharge Caution..... 29 13.4 Glossary 29 14 Mechanical, Packaging, and Orderable Information 29
---	---

4 Revision History

NOTE: Page numbers for previous revisions may differ from page numbers in the current version.

Changes from Original (March 2009) to Revision A	Page
<ul style="list-style-type: none"> • Added <i>Pin Configuration and Functions</i> section, <i>ESD Ratings</i> table, <i>Feature Description</i> section, <i>Device Functional Modes</i>, <i>Application and Implementation</i> section, <i>Power Supply Recommendations</i> section, <i>Layout</i> section, <i>Device and Documentation Support</i> section, and <i>Mechanical, Packaging, and Orderable Information</i> section 1 	1

5 Description (continued)

An additional 8-bit resolution (256 steps) group PWM controller has both a fixed frequency of 190 Hz and an adjustable frequency between 24 Hz to once every 10.73 seconds with a duty cycle that is adjustable from 0% to 99.6% that is used to either dim or blink all LEDs with the same value.

Each LED output can be off, on (no PWM control), set at its individual PWM controller value or at both individual and group PWM controller values. The TLC59208F operates with a supply voltage range of 3 V to 5.5 V and the outputs are 17 V tolerant. LEDs can be directly connected to the TLC59208F device outputs.

Software programmable LED Group and three Sub Call I²C bus addresses allow all or defined groups of TLC59208F devices to respond to a common I²C bus address, allowing for example, all the same color LEDs to be turned on or off at the same time or marquee chasing effect, thus minimizing I²C bus commands.

Three hardware address pins allow up to 64 devices on the same bus.

The software reset (SWRST) Call allows the master to perform a reset of the TLC59208F through the I²C bus, identical to the power-on reset (POR) that initializes the registers to their default state causing the outputs to be set high (LED off). This allows an easy and quick way to reconfigure all device registers to the same condition.

6 Pin Configuration and Functions

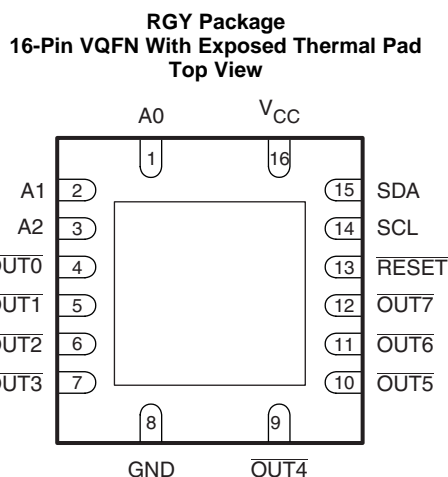
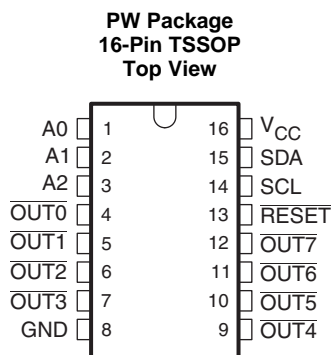

Pin Functions

PIN		I/O ⁽¹⁾	DESCRIPTION
NAME	NO.		
A0	1	I	Address input 0
A1	2	I	Address input 1
A2	3	I	Address input 2
GND	8	—	Ground
OUT0	4	O	Open-drain output 0 to 7, LED ON at low
OUT1	5		
OUT2	6		
OUT3	7		
OUT4	9		
OUT5	10		
OUT6	11		
OUT7	12		
RESET	13	I	Active-low reset input
SCL	14	I	Serial clock input

(1) I = input, O = output

Pin Functions (continued)

PIN		I/O ⁽¹⁾	DESCRIPTION
NAME	NO.		
SDA	15	I/O	Serial data input/output
V _{CC}	16	—	Power supply

7 Specifications

7.1 Absolute Maximum Ratings

 over operating free-air temperature range (unless otherwise noted)⁽¹⁾

		MIN	MAX	UNIT
V _{CC}	Supply voltage	0	7	V
V _I	Input voltage	−0.4	7	V
V _O	Output voltage	−0.5	20	V
I _O	Continuous output current		50	mA
θ _{JA}	Package thermal impedance	PW package ⁽²⁾	108	°C/W
		RGY package ⁽³⁾	39	
P _D	Power Dissipation, T _A = 25 °C, JESD 51-7	PW package	0.90	W
		RGY package	2.08	
T _J	Junction temperature	−40	150	°C
T _{stg}	Storage temperature	−55	150	°C

(1) Stresses beyond those listed under *Absolute Maximum Ratings* may cause permanent damage to the device. These are stress ratings only, which do not imply functional operation of the device at these or any other conditions beyond those indicated under *Recommended Operating Conditions*. Exposure to absolute-maximum-rated conditions for extended periods may affect device reliability.

(2) The package thermal impedance is calculated in accordance with JESD 51-7.

(3) The package thermal impedance is calculated in accordance with JESD 51-5.

7.2 ESD Ratings

		VALUE	UNIT
V _(ESD)	Electrostatic discharge	Human body model (HBM), per ANSI/ESDA/JEDEC JS-001 ⁽¹⁾	±2000
		Charged-device model (CDM), per JEDEC specification JESD22-C101 ⁽²⁾	±500

(1) JEDEC document JEP155 states that 500-V HBM allows safe manufacturing with a standard ESD control process.

(2) JEDEC document JEP157 states that 250-V CDM allows safe manufacturing with a standard ESD control process.

7.3 Recommended Operating Conditions

over operating free-air temperature range (unless otherwise noted)⁽¹⁾

			MIN	MAX	UNIT
V _{CC}	Supply voltage		3	5.5	V
V _{IH}	High-level input voltage	SCL, SDA, $\overline{\text{RESET}}$, A0, A1, A2	0.7 × V _{CC}	5.5	V
V _{IL}	Low-level input voltage	SCL, SDA, $\overline{\text{RESET}}$, A0, A1, A2	0	0.3 × V _{CC}	V
V _O	Output voltage	$\overline{\text{OUT0}}$ to $\overline{\text{OUT7}}$		17	V
I _{OL}	Low-level output current	SDA	V _{CC} = 3 V	20	mA
			V _{CC} = 4.5 V	30	
I _O	Output current	$\overline{\text{OUT0}}$ to $\overline{\text{OUT7}}$		50	mA
T _A	Operating free-air temperature		−40	85	°C

(1) All unused inputs of the device must be held at V_{CC} or GND to ensure proper device operation.

7.4 Thermal Information

THERMAL METRIC ⁽¹⁾		TLC59208F		UNIT
		PW (TSSOP)	RGY (VQFN)	
		16 PINS	16 PINS	
R _{θJA}	Junction-to-ambient thermal resistance	108	39	°C/W

(1) For more information about traditional and new thermal metrics, see the *Semiconductor and IC Package Thermal Metrics* application report, [SPRA953](#).

7.5 Electrical Characteristics

V_{CC} = 3 V to 5.5 V, T_A = −40°C to 85°C (unless otherwise noted)

PARAMETER		TEST CONDITIONS	MIN	TYP ⁽¹⁾	MAX	UNIT
I _I	Input/output leakage current	SCL, SDA, A0, A1, A2, $\overline{\text{RESET}}$ V _I = V _{CC} or GND			±0.3	μA
	Output leakage current	$\overline{\text{OUT0}}$ to $\overline{\text{OUT7}}$ V _O = 17 V, T _J = 25°C			0.5	μA
V _{POR}	Power-on reset voltage			2.5		V
I _{OL}	Low-level output current	SDA	V _{CC} = 3 V, V _{OL} = 0.4 V	20		mA
			V _{CC} = 4.5 V, V _{OL} = 0.4 V	30		
V _{OL}	Low-level output voltage	$\overline{\text{OUT0}}$ to $\overline{\text{OUT7}}$	V _{CC} = 3 V, I _{OL} = 50 mA	108	185	mV
			V _{CC} = 4.5 V, I _{OL} = 50 mA	90	165	
r _{ON}	ON-state resistance	$\overline{\text{OUT0}}$ to $\overline{\text{OUT7}}$	V _{CC} = 3 V, I _{OL} = 50 mA	2	3.75	Ω
			V _{CC} = 4.5 V, I _{OL} = 50 mA	1.8	3.3	
T _{SD}	Thermal shutdown temperature ⁽²⁾		150	175	200	°C
T _{HYS}	Restart hysteresis			15		°C
C _i	Input capacitance	SCL, A0, A1, A2, $\overline{\text{RESET}}$ V _I = V _{CC} or GND		6		pF
C _{io}	Input/output capacitance	SDA V _I = V _{CC} or GND		8		pF
I _{CC}	Supply current	V _{CC} = 3.3 V, $\overline{\text{OUT0}}$ to $\overline{\text{OUT7}}$ = OFF			5	mA
		V _{CC} = 5.5 V, $\overline{\text{OUT0}}$ to $\overline{\text{OUT7}}$ = OFF			8	

(1) All typical values are at T_J = 25°C.

(2) Specified by design, not production tested.

7.6 I²C Interface Timing Requirements

 $T_A = -40^{\circ}\text{C to } 85^{\circ}\text{C}$

		STANDARD-MODE I ² C BUS		FAST-MODE I ² C BUS		FAST-MODE PLUS I ² C BUS		UNIT
		MIN	MAX	MIN	MAX	MIN	MAX	
I²C INTERFACE								
f_{SCL}	SCL clock frequency	0	100	0	400	0	1000	kHz
t_{BUF}	I ² C bus free time between stop and start	4.7		1.3		0.5		μs
$t_{\text{HD;STA}}$	Hold time (repeated) Start condition	4		0.6		0.26		μs
$t_{\text{SU;STA}}$	Set-up time for a repeated Start condition	4.7		0.6		0.26		μs
$t_{\text{SU;STO}}$	Set-up time for Stop condition	4		0.6		0.26		μs
$t_{\text{HD;DAT}}$	Data hold time	0		0		0		ns
$t_{\text{VD;ACK}}$	Data valid acknowledge time ⁽¹⁾	0.3	3.45	0.1	0.9	0.05	0.45	μs
$t_{\text{VD;DAT}}$	Data valid time ⁽²⁾	0.3	3.45	0.1	0.9	0.05	0.45	μs
$t_{\text{SU;DAT}}$	Data set-up time	250		100		50		ns
t_{LOW}	Low period of the SCL clock	4.7		1.3		0.5		μs
t_{HIGH}	High period of the SCL clock	4		0.6		0.26		μs
t_f	Fall time of both SDA and SCL signals ^{(3) (4)}		300	$20+0.1C_b$ ⁽⁵⁾	300		120	ns
t_r	Rise time of both SDA and SCL signals		1000	$20+0.1C_b$ ⁽⁵⁾	300		120	ns
t_{SP}	Pulse width of spikes that must be suppressed by the input filter ⁽⁶⁾		50		50		50	ns
RESET								
t_W	Reset pulse width	10		10		10		ns
t_{REC}	Reset recovery time	0		0		0		ns
t_{RESET}	Time to reset ^{(7) (8)}	400		400		400		ns

(1) $t_{\text{VD;ACK}}$ = time for Acknowledgement signal from SCL low to SDA (out) low.

(2) $t_{\text{VD;DAT}}$ = minimum time for SDA data out to be valid following SCL low.

(3) A master device must internally provide a hold time of at least 300 ns for the SDA signal (refer to the VIL of the SCL signal) in order to bridge the undefined region of SCLs falling edge.

(4) The maximum t_f for the SDA and SCL bus lines is specified at 300 ns. The maximum fall time (t_f) for the SDA output stage is specified at 250 ns. This allows series protection resistors to be connected between the SDA and the SCL pins and the SDA/SCL bus lines without exceeding the maximum specified t_f .

(5) C_b = total capacitance of one bus line in pF.

(6) Input filters on the SDA and SCL inputs suppress noise spikes less than 50 ns

(7) Resetting the device while actively communicating on the bus may cause glitches or errant Stop conditions.

(8) Upon reset, the full delay will be the sum of t_{RESET} and the RC time constant of the SDA bus.

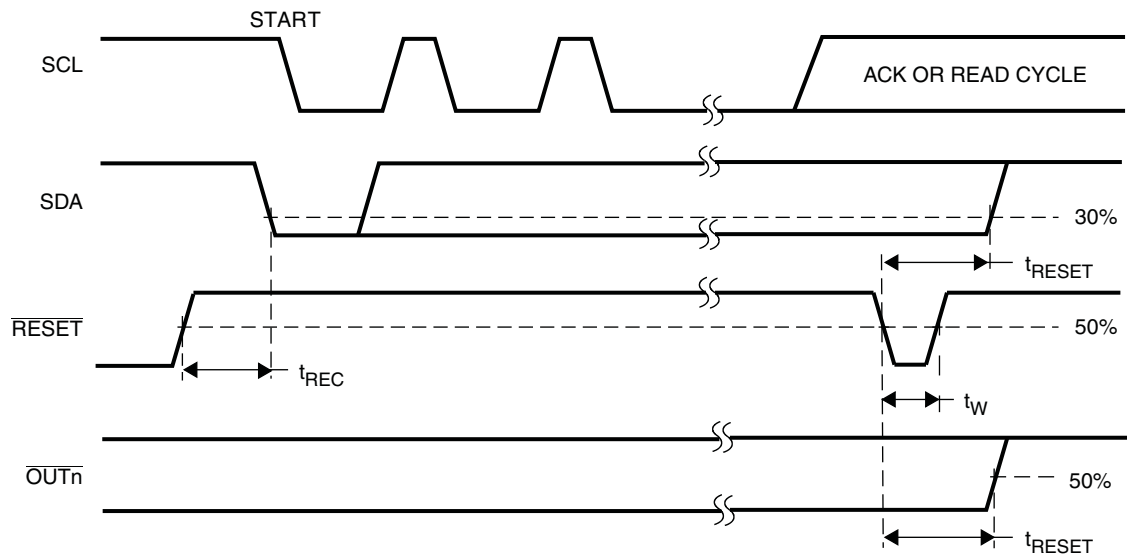

Figure 1. Definition of RESET Timing

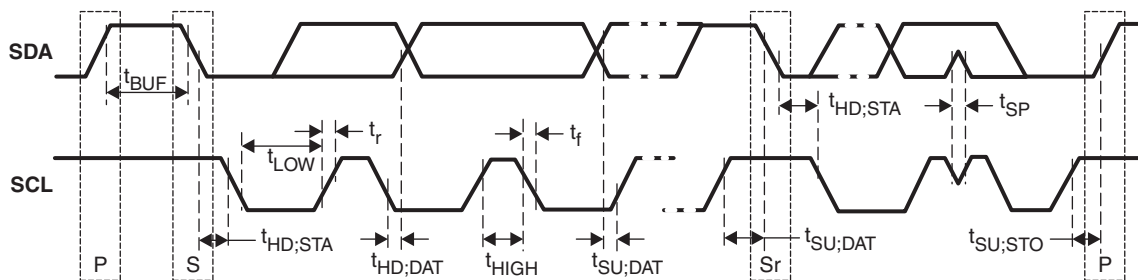
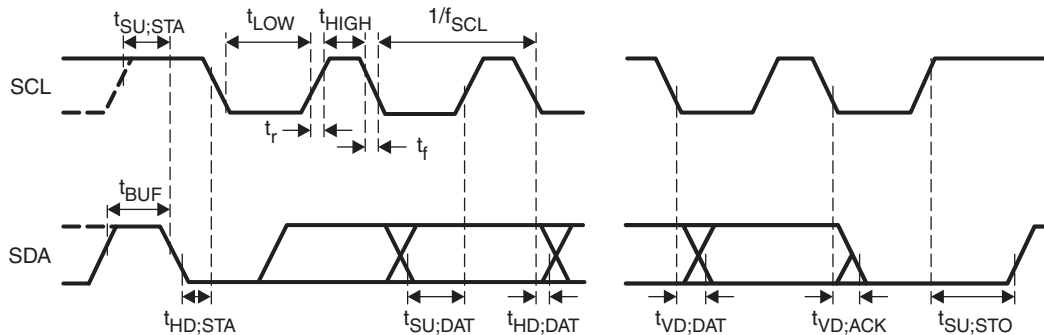

Figure 2. Definition of Timing

Protocol	Start Condition (S)	Bit 7 MSB (A7)	Bit 6 (A6)	Bit 7 (D1)	Bit 8 (D0)	Acknowledge (A)	Stop Condition (P)
----------	---------------------	----------------	------------	------------	------------	-----------------	--------------------



NOTE: Rise and fall times refer to V_{IL} and V_{IH} .

Figure 3. I²C Bus Timing

7.7 Typical Characteristics

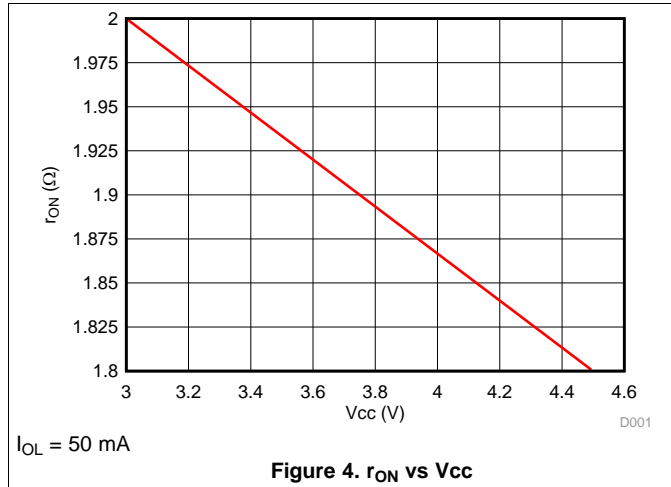

Figure 4. r_{ON} vs V_{CC}

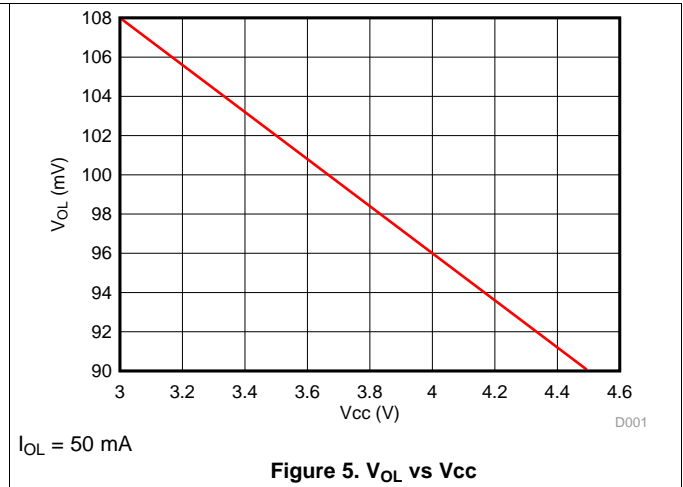
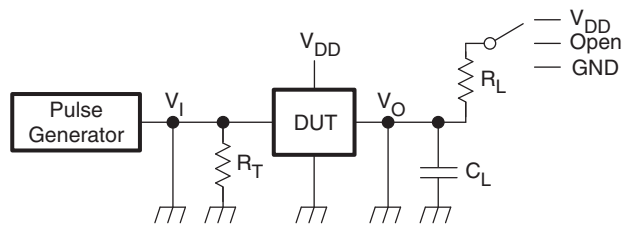

Figure 5. V_{OL} vs V_{CC}

8 Parameter Measurement Information



NOTE: R_L = Load resistance for SDA and SCL; should be >1 k Ω at 3-mA or lower current.
 C_L = Load capacitance; includes jig and probe capacitance.
 R_T = Termination resistance; should be equal to the output impedance (Z_O) of the pulse generator.

Figure 6. Test Circuit for Switching Characteristics

9 Detailed Description

9.1 Overview

The TLC59208F is an I²C bus controlled 8-bit LED driver optimized for red, green, blue, or amber (RGBA) colormixing applications. Each LED output has its own 8-bit resolution (256 steps) fixed frequency individual PWM controller that operates at 97 kHz with a duty cycle adjustable from 0% to 99.6% to allow the LED to be set to a specific brightness value. An additional 8-bit resolution (256 steps) group PWM controller has both a fixed frequency of 190 Hz and an adjustable frequency between 24 Hz to once every 10.73 seconds with a duty cycle adjustable from 0% to 99.6% that can either dim or blink all LEDs with the same value.

Each LED output can be off, on (no PWM control), set at its individual PWM controller value or at both individual and group PWM controller values. The TLC59208F operates with a supply voltage range of 3 V to 5.5 V and the outputs are 17 V tolerant. LEDs can be directly connected to the TLC59208F device outputs.

Software programmable LED group and three sub call I²C bus addresses allow all or defined groups of TLC59208F devices to respond to a common I²C bus address, allowing for example, all the same color LEDs to be turned on or off at the same time or marquee chasing effect, thus minimizing I²C bus commands.

The software reset (SWRST) call allows the master to perform a reset of the TLC59208F through the I²C bus, identical to the power-on reset (POR) that initializes the registers to their default state causing the outputs to be set high (LED off). This allows an easy and quick way to reconfigure all device registers to the same condition.

9.2 Functional Block Diagram

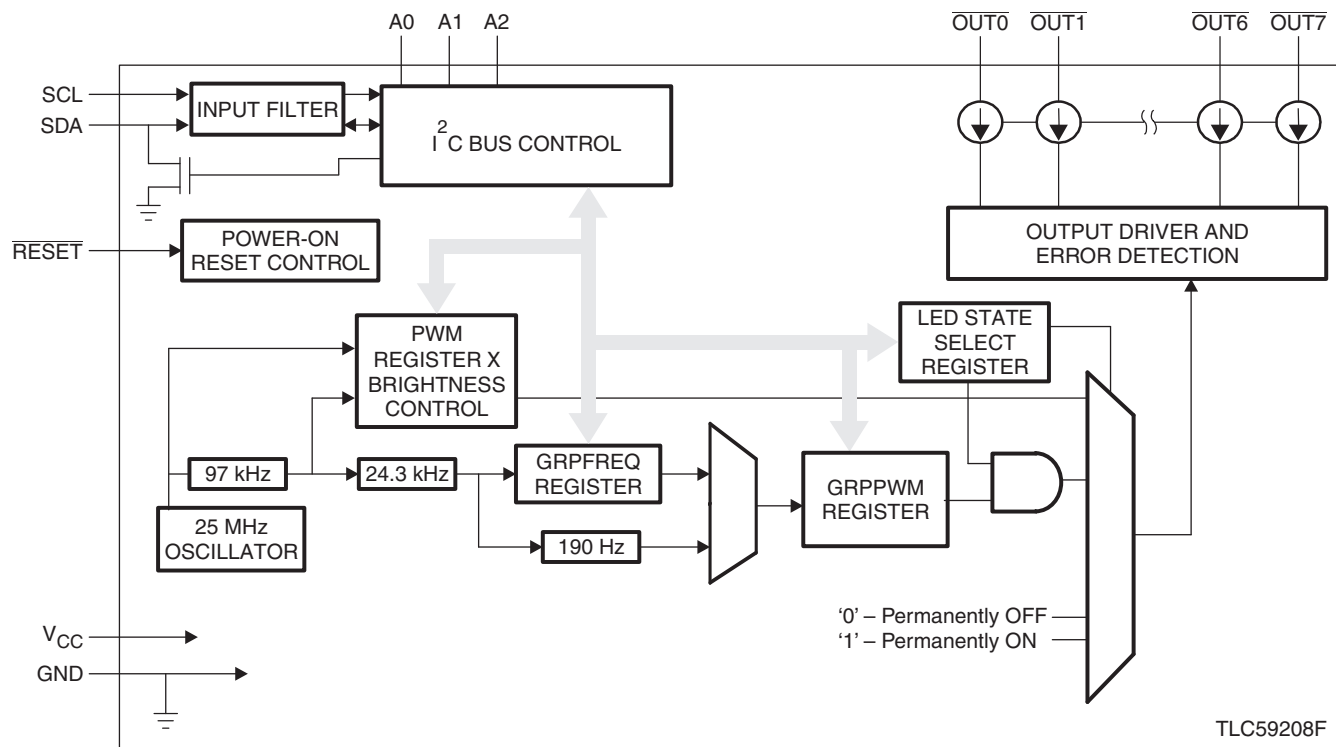

NOTE: Only one PWM shown for clarity.

9.3 Feature Description

9.3.1 Power-On Reset

When power is applied to V_{CC} , an internal power-on reset holds the TLC59208F in a reset condition until V_{CC} has reached V_{POR} . At this point, the reset condition is released and the TLC59208F registers and I²C bus state machine are initialized to their default states causing all the channels to be deselected. Thereafter, V_{CC} must be lowered below 0.2 V to reset the device.

Feature Description (continued)

9.3.2 External Reset

A reset can be accomplished by holding the $\overline{\text{RESET}}$ pin low for a minimum of t_W . The TLC59208F registers and I²C state machine will be held in their default state until the $\overline{\text{RESET}}$ input is once again high.

This input requires a pull-up resistor to V_{CC} if no active connection is used.

9.3.3 Software Reset

The Software Reset Call (SWRST Call) allows all the devices in the I²C bus to be reset to the power-up state value through a specific I²C bus command. To be performed correctly, the I²C bus must be functional and there must be no device hanging the bus.

The SWRST Call function is defined as the following:

1. A Start command is sent by the I²C bus master.
2. The reserved SWRST I²C bus address 1001 111 with the $\overline{\text{R/W}}$ bit set to 0 (write) is sent by the I²C bus master.
3. The TLC59208F device(s) acknowledge(s) after seeing the SWRST Call address 1001 0110 (9Eh) only. If the $\overline{\text{R/W}}$ bit is set to 1 (read), no acknowledge is returned to the I²C bus master.
4. Once the SWRST Call address has been sent and acknowledged, the master sends two bytes with two specific values (SWRST data byte 1 and byte 2):
 - (a) Byte1 = A5h: the TLC59208F acknowledges this value only. If byte 1 is not equal to A5h, the TLC59208F does not acknowledge it.
 - (b) Byte 2 = 5Ah: the TLC59208F acknowledges this value only. If byte 2 is not equal to 5Ah, the TLC59208F does not acknowledge it.

If more than two bytes of data are sent, the TLC59208F does not acknowledge any more.

5. Once the correct two bytes (SWRST data byte 1 and byte 2 only) have been sent and correctly acknowledged, the master sends a Stop command to end the SWRST Call. The TLC59208F then resets to the default value (power-up value) and is ready to be addressed again within the specified bus free time (t_{BUF}).

The I²C bus master may interpret a non-acknowledge from the TLC59208F (at any time) as a SWRST Call Abort. The TLC59208F does not initiate a reset of its registers. This happens only when the format of the Start Call sequence is not correct.

9.3.4 Individual Brightness Control With Group Dimming/Blinking

A 97-kHz fixed frequency signal with programmable duty cycle (8 bits, 256 steps) is used to control individually the brightness for each LED.

On top of this signal, one of the following signals can be superimposed (this signal can be applied to the 4 LED outputs):

- A lower 190-Hz fixed frequency signal with programmable duty cycle (8 bits, 256 steps) is used to provide a global brightness control.
- A programmable frequency signal from 24 Hz to 1/10.73 s (8 bits, 256 steps) is used to provide a global blinking control.

Feature Description (continued)

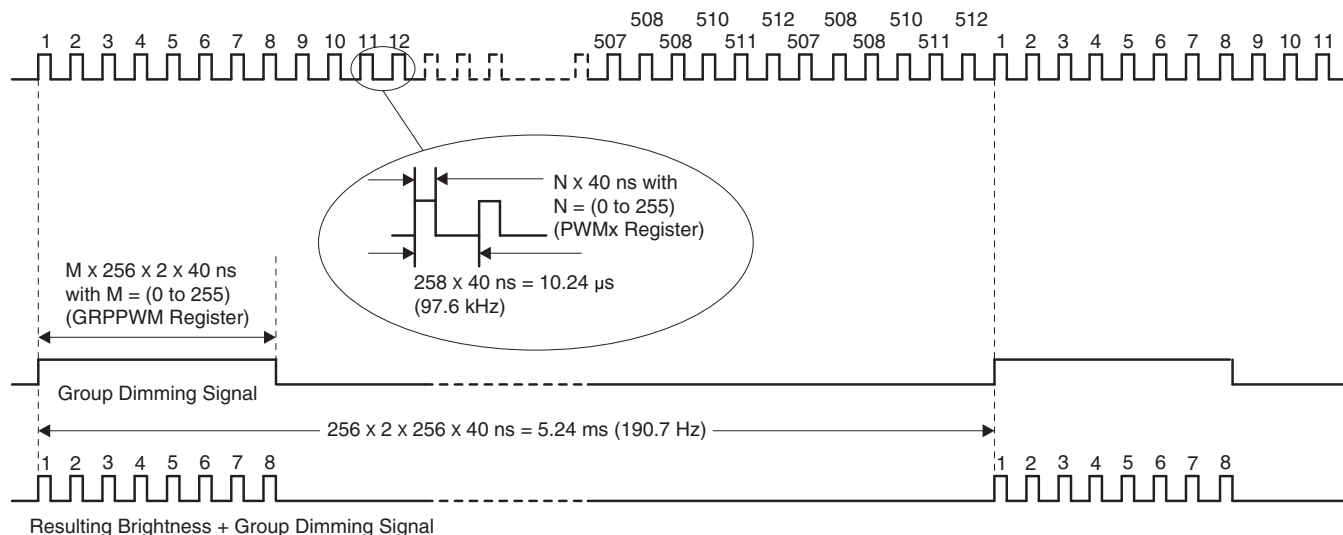

- A. Minimum pulse width for LEDn brightness control is 40 ns.
- B. Minimum pulse width for group dimming is 20.48 μs.
- C. When M = 1 (GRPPWM register value), the resulting LEDn brightness control and group dimming signal will have two pulses of the LED brightness control signal (pulse width = N x 40 ns, with N defined in the PWMx register).
- D. The resulting brightness plus group dimming signal shown above demonstrate a resulting control signal with M = 4 (8 pulses).

Figure 7. Brightness + Group Dimming Signals

9.4 Device Functional Modes

Active Active mode occurs when one or more of the output channels is enabled.

Standby Standby mode occurs when all output channels are disabled. Standby mode may be entered either through I2C command or by pulling the RESET pin low.

9.5 Programming

9.5.1 Characteristics of the I²C Bus

The I²C bus is for two-way two-line communication between different devices or modules. The two lines are a serial data line (SDA) and a serial clock line (SCL). Both lines must be connected to a positive supply via a pullup resistor when connected to the output stages of a device. Data transfer may be initiated only when the bus is not busy.

9.5.1.1 Bit Transfer

One data bit is transferred during each clock pulse. The data on the SDA line must remain stable during the high period of the clock pulse as changes in the data line at this time will be interpreted as control signals (see Figure 8).

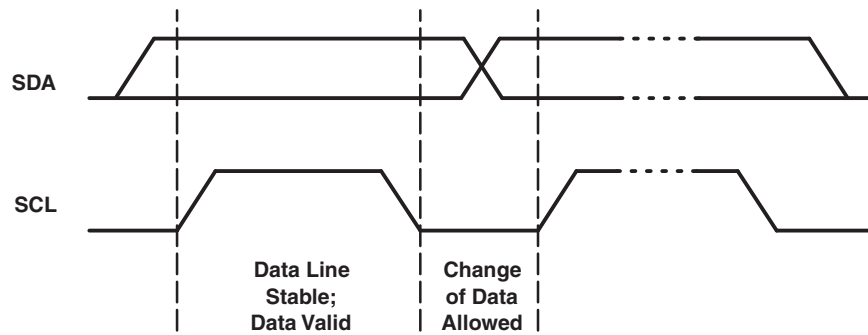
Programming (continued)

Figure 8. Bit Transfer
9.5.1.2 Start and Stop Conditions

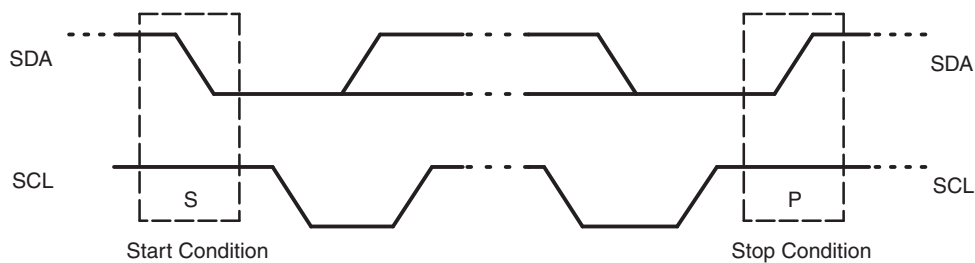
Both data and clock lines remain high when the bus is not busy. A high-to-low transition of the data line while the clock is high is defined as the Start condition (S). A low-to-high transition of the data line while the clock is high is defined as the Stop condition (P) (see [Figure 9](#)).

Figure 9. Start and Stop Conditions

Programming (continued)

9.5.2 System Configuration

A device generating a message is a transmitter; a device receiving is the receiver. The device that controls the message is the master and the devices which are controlled by the master are the slaves (see Figure 10).

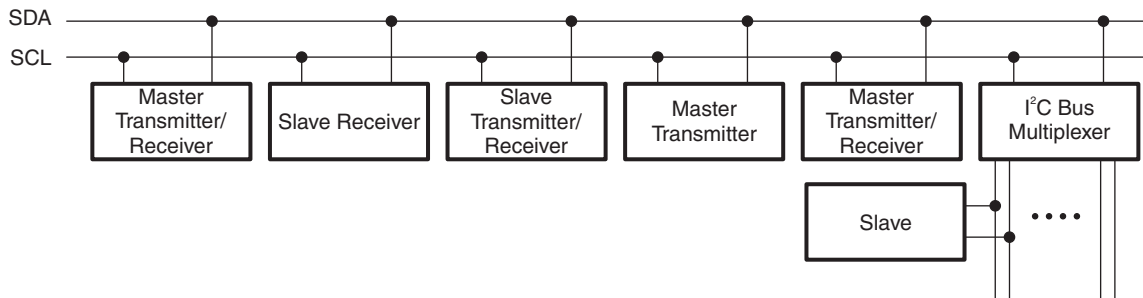

Figure 10. System Configuration

9.5.3 Acknowledge

The number of data bytes transferred between the Start and the Stop conditions from transmitter to receiver is not limited. Each byte of eight bits is followed by one acknowledge bit. The acknowledge bit is a high level put on the bus by the transmitter, whereas the master generates an extra acknowledge related clock pulse.

A slave receiver which is addressed must generate an acknowledge after the reception of each byte. Also a master must generate an acknowledge after the reception of each byte that has been clocked out of the slave transmitter. The device that acknowledges has to pull down the SDA line during the acknowledge related clock pulse, so that the SDA line is stable low during the high period of the acknowledge related clock pulse; set-up time and hold time must be taken into account.

A master receiver must signal an end of data to the transmitter by not generating an acknowledge on the last byte that has been clocked out of the slave. In this event, the transmitter must leave the data line high to enable the master to generate a Stop condition.

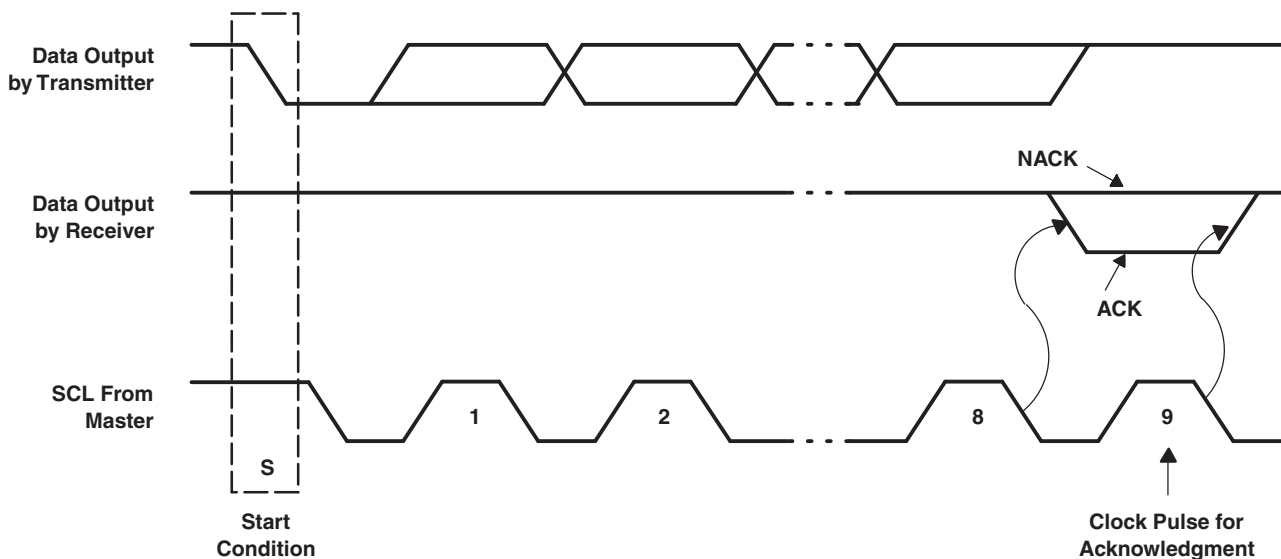

Figure 11. Acknowledge on I²C Bus

Programming (continued)

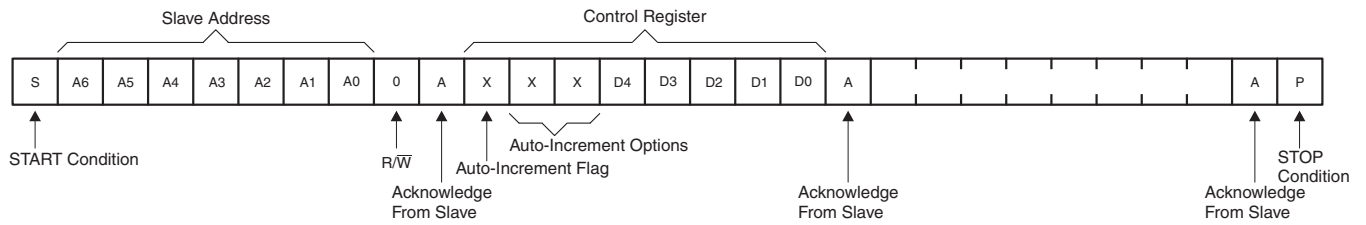

Figure 12. Write to a Specific Register

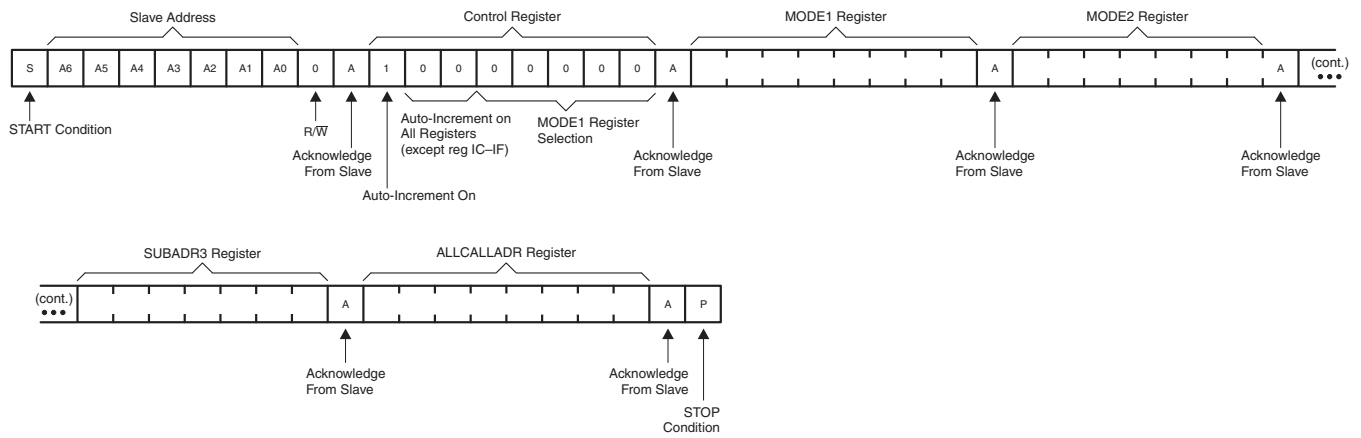

Figure 13. Write to All Registers Using Auto-Increment

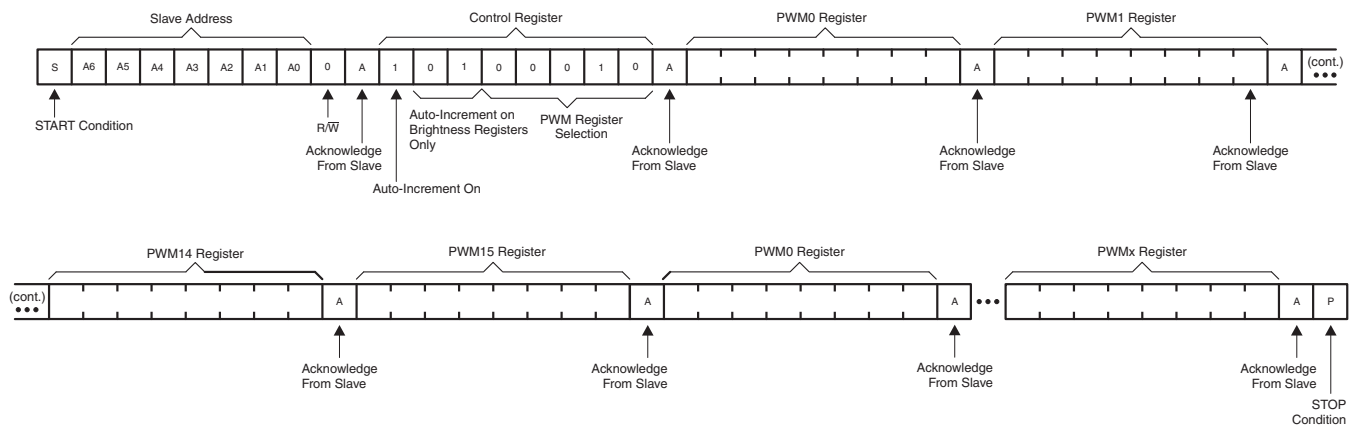

Figure 14. Multiple Writes to Individual Brightness Registers Only Using the Auto-Increment Feature

Programming (continued)

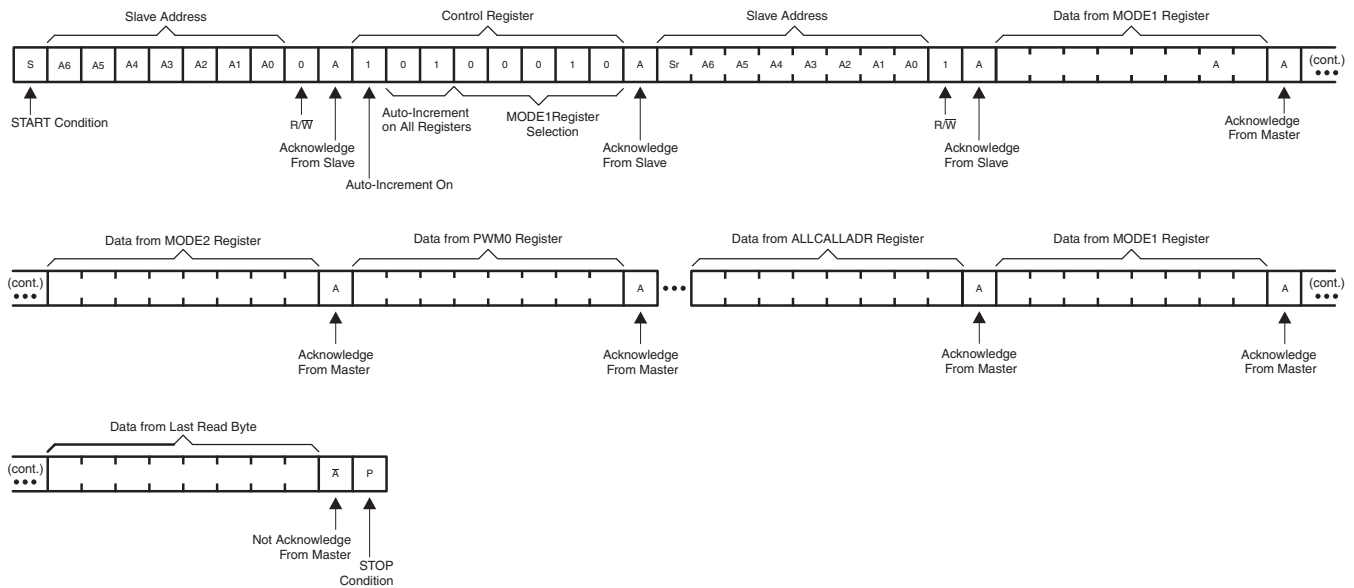
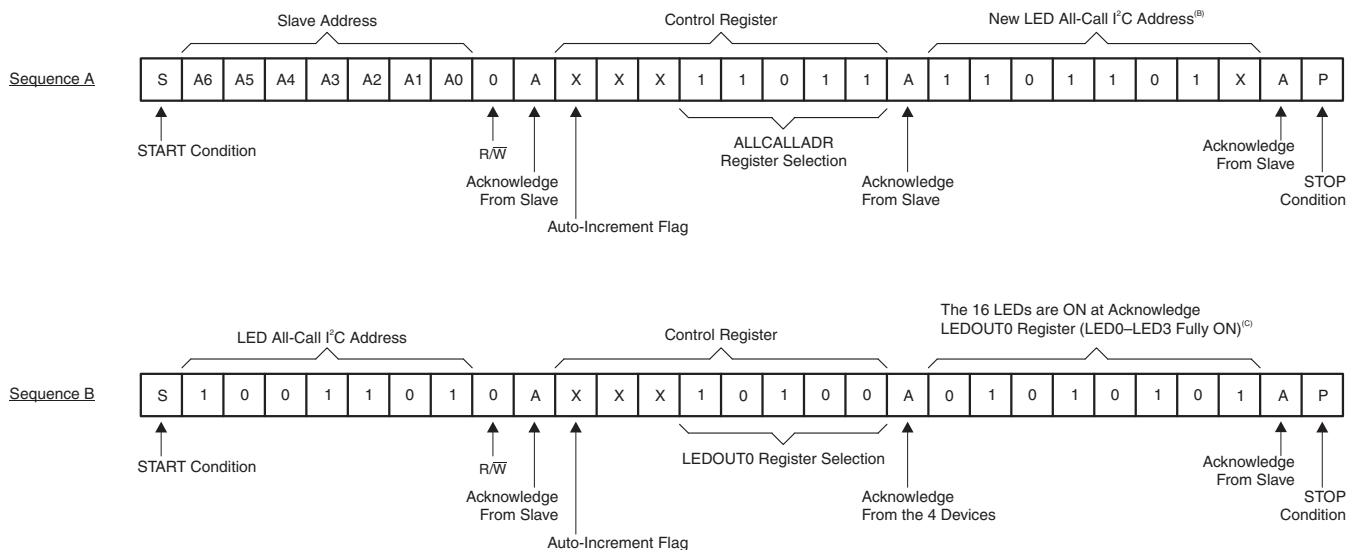

Figure 15. Read All Registers With the Auto-Increment Feature



- A. In this example, several TLC59208Fs are used with the same sequence sent to each.
- B. ALLCALL bit in MODE1 register is equal to 1 for this example.
- C. OCH bit in MODE2 register is equal to 1 for this example.

Figure 16. LED All-Call I²C Bus Address Programming and LED All-Call Sequence Example

9.5.4 Device Address

Following a Start condition, the bus master must output the address of the slave it is accessing.

Programming (continued)

9.5.5 Regular I²C Bus Slave Address

The I²C bus slave address of the TLC59208F is shown in Figure 17. Slave address pins A0, A1, and A2 choose 1 of 64 slave addresses. To conserve power, no internal pullup resistors are incorporated on A0, A1, or A2. Address values, depending on A0, A1, and A2, can be found in Table 1.

NOTE

When using the TLC59208F, reserved I²C bus addresses must be used with caution since they can interfere with the following:

- Reserved for future use I²C bus addresses (0000 011, 1111 101, 1111 110, 1111 111)
- Slave devices that use the 10-bit addressing scheme (1111 0xx)
- High-speed mode master code (0000 1xx)

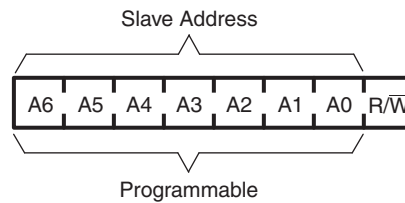

Figure 17. Slave Address

The last bit of the address byte defines the operation to be performed. When set to logic 1, a read operation is selected. When set to logic 0, a write operation is selected.

9.5.5.1 Regular I²C Bus Slave Address

Table 1. TLC59208F Address Map

ADDRESS INPUT			SLAVE ADDRESS							ADDRESS
A2	A1	A0	A6	A5	A4	A3	A2	A1	A0	
GND	SCL	GND	0	0	1	0	0	0	0	20h
GND	SCL	V _{CC}	0	0	1	0	0	0	1	22h
GND	SDA	GND	0	0	1	0	0	1	0	24h
GND	SDA	V _{CC}	0	0	1	0	0	1	1	26h
V _{CC}	SCL	GND	0	0	1	0	1	0	0	28h
V _{CC}	SCL	V _{CC}	0	0	1	0	1	0	1	2Ah
V _{CC}	SDA	GND	0	0	1	0	1	1	0	2Ch
V _{CC}	SDA	V _{CC}	0	0	1	0	1	1	1	2Eh
GND	SCL	SCL	0	0	1	1	0	0	0	30h
GND	SCL	SDA	0	0	1	1	0	0	1	32h
GND	SDA	SCL	0	0	1	1	0	1	0	34h
GND	SDA	SDA	0	0	1	1	0	1	1	36h
V _{CC}	SCL	SCL	0	0	1	1	1	0	0	38h
V _{CC}	SCL	SDA	0	0	1	1	1	0	1	3Ah
V _{CC}	SDA	SCL	0	0	1	1	1	1	0	3Ch
V _{CC}	SDA	SDA	0	0	1	1	1	1	1	3Eh
GND	GND	GND	0	1	0	0	0	0	0	40h
GND	GND	V _{CC}	0	1	0	0	0	0	1	42h
GND	V _{CC}	GND	0	1	0	0	0	1	0	44h
GND	V _{CC}	V _{CC}	0	1	0	0	0	1	1	46h
V _{CC}	GND	GND	0	1	0	0	1	0	0	48h

Programming (continued)
Table 1. TLC59208F Address Map (continued)

ADDRESS INPUT			SLAVE ADDRESS							ADDRESS
A2	A1	A0	A6	A5	A4	A3	A2	A1	A0	
V _{CC}	GND	V _{CC}	0	1	0	0	1	0	1	4Ah
V _{CC}	V _{CC}	GND	0	1	0	0	1	1	0	4Ch
V _{CC}	V _{CC}	V _{CC}	0	1	0	0	1	1	1	4Eh
GND	GND	SCL	0	1	0	1	0	0	0	50h
GND	GND	SDA	0	1	0	1	0	0	1	52h
GND	V _{CC}	SCL	0	1	0	1	0	1	0	54h
GND	V _{CC}	SDA	0	1	0	1	0	1	1	56h
V _{CC}	GND	SCL	0	1	0	1	1	0	0	58h
V _{CC}	GND	SDA	0	1	0	1	1	0	1	5Ah
V _{CC}	V _{CC}	SCL	0	1	0	1	1	1	0	5Ch
V _{CC}	V _{CC}	SDA	0	1	0	1	1	1	1	5Eh
SCL	SCL	GND	1	0	1	0	0	0	0	A0h
SCL	SCL	V _{CC}	1	0	1	0	0	0	1	A2h
SCL	SDA	GND	1	0	1	0	0	1	0	A4h
SCL	SDA	V _{CC}	1	0	1	0	0	1	1	A6h
SDA	SCL	GND	1	0	1	0	1	0	0	A8h
SDA	SCL	V _{CC}	1	0	1	0	1	0	1	AAh
SDA	SDA	GND	1	0	1	0	1	1	0	ACH
SDA	SDA	V _{CC}	1	0	1	0	1	1	1	A Eh
SCL	SCL	SCL	1	0	1	1	0	0	0	B0h
SCL	SCL	SDA	1	0	1	1	0	0	1	B2h
SCL	SDA	SCL	1	0	1	1	0	1	0	B4h
SCL	SDA	SDA	1	0	1	1	0	1	1	B6h
SDA	SCL	SCL	1	0	1	1	1	0	0	B8h
SDA	SCL	SDA	1	0	1	1	1	0	1	BAh
SDA	SDA	SCL	1	0	1	1	1	1	0	BCh
SDA	SDA	SDA	1	0	1	1	1	1	1	BEh
SCL	GND	GND	1	1	0	0	0	0	0	C0h
SCL	GND	V _{CC}	1	1	0	0	0	0	1	C2h
SCL	V _{CC}	GND	1	1	0	0	0	1	0	C4h
SCL	V _{CC}	V _{CC}	1	1	0	0	0	1	1	C6h
SDA	GND	GND	1	1	0	0	1	0	0	C8h
SDA	GND	V _{CC}	1	1	0	0	1	0	1	CAh
SDA	V _{CC}	GND	1	1	0	0	1	1	0	CCh
SDA	V _{CC}	V _{CC}	1	1	0	0	1	1	1	CEh
SCL	GND	SCL	1	1	1	0	0	0	0	E0h
SCL	GND	SDA	1	1	1	0	0	0	1	E2h
SCL	V _{CC}	SCL	1	1	1	0	0	1	0	E4h
SCL	V _{CC}	SDA	1	1	1	0	0	1	1	E6h
SDA	GND	SCL	1	1	1	0	1	0	0	E8h
SDA	GND	SDA	1	1	1	0	1	0	1	E Ah
SDA	V _{CC}	SCL	1	1	1	0	1	1	0	ECh
SDA	V _{CC}	SDA	1	1	1	0	1	1	1	EEh

9.5.6 LED All Call I²C Bus Address

- Default power-up value (ALLCALLADR address register): 90h or 1001 000
- Programmable through I²C bus (volatile programming)
- At power-up, LED All Call I²C bus address is enabled. TLC59208F sends an ACK when 90h (R/W = 0) or 91h (R/W = 1) is sent by the master.

NOTE

The default LED All Call I²C bus address (90h or 1001 000) must not be used as a regular I²C bus slave address since this address is enabled at power-up. All the TLC59208Fs on the I²C bus will acknowledge the address if sent by the I²C bus master.

9.5.7 LED Sub Call I²C Bus Address

- Three different I²C bus addresses can be used
- Default power-up values:
 - SUBADR1 register: 92h or 1001 001
 - SUBADR2 register: 94h or 1001 010
 - SUBADR3 register: 98h or 1001 100
- Programmable through I²C bus (volatile programming)
- At power-up, Sub Call I²C bus address is disabled. TLC59208F does not send an ACK when 92h (R/W = 0) or 93h (R/W = 1) or 94h (R/W = 0) or 95h (R/W = 1) or 98h (R/W = 0) or 99h (R/W = 1) is sent by the master.

NOTE

The default LED Sub Call I²C bus address may be used as a regular I²C bus slave address as long as the SUBADR_x bits are disabled.

9.5.8 Software Reset I²C Bus Address

The address shown in [Figure 18](#) is used when a reset of the TLC59208F needs to be performed by the master. The software reset address (SWRST Call) must be used with R/W = 0. If R/W = 1, the TLC59208F does not acknowledge the SWRST. See [Software Reset](#) for more detail.



Figure 18. Software Reset Address

NOTE

The Software Reset I²C bus address is a reserved address and cannot be used as a regular I²C bus slave address or as an LED All Call or LED Sub Call address.

9.5.9 Control Register

Following the successful acknowledgement of the slave address, LED All Call address or LED Sub Call address, the bus master will send a byte to the TLC59208F, which will be stored in the Control register. The lowest 5 bits are used as a pointer to determine which register will be accessed (D[4:0]). The highest 3 bits are used as Auto-Increment flag and Auto-Increment options (AI[2:0]).

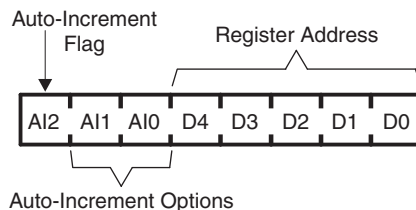

Figure 19. Control Register

When the Auto-Increment flag is set (AI2 = logic 1), the five low order bits of the Control register are automatically incremented after a read or write. This allows the user to program the registers sequentially. Four different types of Auto-Increment are possible, depending on AI1 and AI0 values.

Table 2. Auto-Increment Options⁽¹⁾

AI2	AI1	AI0	DESCRIPTION
0	0	0	No auto-increment
1	0	0	Auto-increment for all registers. D[4:0] roll over to '0 0000' after the last register ('1 0001') is accessed.
1	0	1	Auto-increment for individual brightness registers only. D[4:0] roll over to '0 0010' after the last register ('0 1001') is accessed.
1	1	0	Auto-increment for global control registers only. D[4:0] roll over to '0 1010' after the last register ('0 1011') is accessed.
1	1	1	Auto-increment for individual and global control registers only. D[4:0] roll over to '0 0010' after the last register ('0 1011') is accessed.

(1) Other combinations not shown in Table 2 (AI[2:0] = 001, 010, and 011) are reserved and must not be used for proper device operation.

AI[2:0] = 000 is used when the same register must be accessed several times during a single I²C bus communication, for example, changes the brightness of a single LED. Data is overwritten each time the register is accessed during a write operation.

AI[2:0] = 100 is used when all the registers must be sequentially accessed, for example, power-up programming.

AI[2:0] = 101 is used when the four LED drivers must be individually programmed with different values during the same I²C bus communication, for example, changing color setting to another color setting.

AI[2:0] = 110 is used when the LED drivers must be globally programmed with different settings during the same I²C bus communication, for example, global brightness or blinking change.

AI[2:0] = 111 is used when individually and global changes must be performed during the same I²C bus communication, for example, changing color and global brightness at the same time.

Only the 5 least significant bits D[4:0] are affected by the AI[2:0] bits.

When Control register is written, the register entry point determined by D[4:0] is the first register that will be addressed (read or write operation), and can be anywhere between 0 0000 and 1 0001 (as defined in LINKTOTABLE3). When AI[2] = 1, the Auto-Increment flag is set and the rollover value at which the point where the register increment stops and goes to the next one is determined by AI[2:0]. See for rollover values. For example, if the Control register = 1110 1100 (ECh), then the register addressing sequence will be (in hex):

04 → ... → 11 → 02 → ... → 11 → 02 → ... → 11 as long as the master keeps sending or reading data.

9.6 Register Maps

9.6.1 Register Descriptions

Table 3 describes the registers in the TLC59208F.

Table 3. Register Descriptions

REGISTER NUMBER (HEX)	NAME	ACCESS ⁽¹⁾	DESCRIPTION
00	MODE1	R/W	Mode register 1
01	MODE2	R/W	Mode register 2
02	PWM0	R/W	Brightness control LED0
03	PWM1	R/W	Brightness control LED1
04	PWM2	R/W	Brightness control LED2
05	PWM3	R/W	Brightness control LED3
06	PWM4	R/W	Brightness control LED4
07	PWM5	R/W	Brightness control LED5
08	PWM6	R/W	Brightness control LED6
09	PWM7	R/W	Brightness control LED7
0A	GRPPWM	R/W	Group duty cycle control
0B	GRPFREQ	R/W	Group frequency
0C	LEDOUT0	R/W	LED output state 0
0D	LEDOUT1	R/W	LED output state 1
0E	SUBADR1	R/W	I ² C bus sub-address 1
0F	SUBADR2	R/W	I ² C bus sub-address 2
10	SUBADR3	R/W	I ² C bus sub-address 3
11	ALLCALLADR	R/W	LED all call I ² C bus address

(1) R = read, W = write

9.6.1.1 Mode Register 1 (MODE1)

Table 4 describes Mode Register 1.

Table 4. MODE1 – Mode Register 1 (Address 00h) Bit Description

BIT	SYMBOL	ACCESS ⁽¹⁾	VALUE	DESCRIPTION
7	AI2	R	0 ⁽²⁾	Register auto-increment disabled
			1	Register auto-increment enabled
6	AI1	R	0 ⁽²⁾	Auto-increment bit 1 = 0
			1	Auto-increment bit 1 = 1
5	AI0	R	0 ⁽²⁾	Auto-increment bit 0 = 0
			1	Auto-increment bit 0 = 1
4	SLEEP	R/W	0	Normal mode ⁽³⁾
			1 ⁽²⁾	Low power mode. Oscillator off ⁽⁴⁾ .
3	SUB1	R/W	0 ⁽²⁾	Device does not respond to I ² C bus sub-address 1.
			1	Device responds to I ² C bus sub-address 1.
2	SUB2	R/W	0 ⁽²⁾	Device does not respond to I ² C bus sub-address 2.
			1	Device responds to I ² C bus sub-address 2.

(1) R = read, W = write

(2) Default value

(3) It takes 500 μ s max. for the oscillator to be up and running once SLEEP bit has been set from logic 1 to 0. Timings on LEDn outputs are not guaranteed if PWMx, GRPPWM, or GRPFREQ registers are accessed within the 500 μ s window.

(4) No LED control (on, off, blinking, or dimming) is possible when the oscillator is off. Write to a register cannot be accepted during SLEEP mode. When you change the LED condition, SLEEP bit must be set to logic 0.

Table 4. MODE1 – Mode Register 1 (Address 00h) Bit Description (continued)

BIT	SYMBOL	ACCESS ⁽¹⁾	VALUE	DESCRIPTION
1	SUB3	R/W	0 ⁽²⁾	Device does not respond to I ² C bus sub-address 3.
			1	Device responds to I ² C bus sub-address 3.
0	ALLCALL	R/W	0	Device does not respond to LED All Call I ² C bus address.
			1 ⁽²⁾	Device responds to LED All Call I ² C bus address.

9.6.1.2 Mode Register 2 (MODE2)

Table 5 describes Mode Register 2.

Table 5. MODE2 – Mode Register 2 (Address 01h) Bit Description

BIT	SYMBOL	ACCESS ⁽¹⁾	VALUE	DESCRIPTION
7:6		R	00 ⁽²⁾	Reserved
5	DMBLNK	R/W	0 ⁽³⁾	Group control = dimming
			1	Group control = blinking
4		R	0 ⁽²⁾	Reserved
3	OCH	R/W	0 ⁽²⁾	Outputs change on Stop command ⁽⁴⁾ .
			1	Outputs change on ACK.
2	WDT ENABLE	R/W	0 ⁽²⁾	Disable WDT
			1	Enable WDT
1:0	WDT PERIOD	R/W	00	5 ms
			01	15 ms
			10	25 ms
			11 ⁽²⁾	35 ms

(1) R = read, W = write

(2) Default value

(3) Default value

(4) Change of the outputs at the STOP command allows synchronizing outputs of more than one TLC59208F. Applicable to registers from 02h (PWM0) to 0Dh (LEDOUT) only.

9.6.1.3 Individual Brightness Control Registers (PWM0–PWM7)

Table 6 describes the Individual Brightness Control Registers.

Table 6. PWM0–PWM7 – Individual Brightness Control Registers (Addresses 02h–09h) Bit Description

ADDRESS	REGISTER	BIT	SYMBOL	ACCESS ⁽¹⁾	VALUE	DESCRIPTION
02h	PWM0	7:0	IDC0[7:0]	R/W	0000 0000 ⁽²⁾	PWM0 individual duty cycle
03h	PWM1	7:0	IDC1[7:0]	R/W	0000 0000 ⁽²⁾	PWM1 individual duty cycle
04h	PWM2	7:0	IDC2[7:0]	R/W	0000 0000 ⁽²⁾	PWM2 individual duty cycle
05h	PWM3	7:0	IDC3[7:0]	R/W	0000 0000 ⁽²⁾	PWM3 individual duty cycle
06h	PWM4	7:0	IDC4[7:0]	R/W	0000 0000 ⁽²⁾	PWM4 individual duty cycle
07h	PWM5	7:0	IDC5[7:0]	R/W	0000 0000 ⁽²⁾	PWM5 individual duty cycle
08h	PWM6	7:0	IDC6[7:0]	R/W	0000 0000 ⁽²⁾	PWM6 individual duty cycle
09h	PWM7	7:0	IDC7[7:0]	R/W	0000 0000 ⁽²⁾	PWM7 individual duty cycle

(1) R = read, W = write

(2) Default value

A 97-kHz fixed-frequency signal is used for each output. Duty cycle is controlled through 256 linear steps from 00h (0% duty cycle = LED output off) to FFh (99.6% duty cycle = LED output at maximum brightness). Applicable to LED outputs programmed with LDRx = 10 or 11 (LEDOUT0 and LEDOUT1 registers).

$$\text{duty cycle} = \frac{\text{IDCx}[7:0]}{256}$$

9.6.1.4 Group Duty Cycle Control Register (GRPPWM)

Table 7 describes the Group Duty Cycle Control Register.

Table 7. GRPPWM – Group Duty Cycle Control Register (Address 0Ah) Bit Description

ADDRESS	REGISTER	BIT	SYMBOL	ACCESS ⁽¹⁾	VALUE	DESCRIPTION
0Ah	GRPPWM	7:0	GDC0[7:0]	R/W	1111 1111 ⁽²⁾	GRPPWM register

(1) R = read, W = write

(2) Default value

When DMBLNK bit (MODE2 register) is programmed with logic 0, a 190-Hz fixed frequency signal is superimposed with the 97-kHz individual brightness control signal. GRPPWM is then used as a global brightness control allowing the LED outputs to be dimmed with the same value. The value in GRPFREQ is then a 'Don't care'.

General brightness for the 8 outputs is controlled through 256 linear steps from 00h (0% duty cycle = LED output off) to FFh (99.6% duty cycle = maximum brightness). Applicable to LED outputs programmed with LDRx = 11 (LEDOUT0 and LEDOUT1 registers).

When DMBLNK bit is programmed with logic 1, GRPPWM and GRPFREQ registers define a global blinking pattern, where GRPPWM and GRPFREQ registers define a global blinking pattern, where GRPFREQ contains the blinking period (from 24 Hz to 10.73 s) and GRPPWM the duty cycle (ON/OFF ratio in %).

$$\text{duty cycle} = \frac{\text{GDC}[7:0]}{256}$$

9.6.1.5 Group Frequency Register (GRPFREQ)

Table 7 describes the Group Frequency Register.

Table 8. GRPFREQ – Group Frequency Register (Address 0Bh) Bit Description

ADDRESS	REGISTER	BIT	SYMBOL	ACCESS ⁽¹⁾	VALUE	DESCRIPTION
0Bh	GRPFREQ	7:0	GFRQ[7:0]	R/W	0000 0000 ⁽²⁾	GRPFREQ register

(1) R = read, W = write

(2) Default value

GRPFREQ is used to program the global blinking period when DMBLNK bit (MODE2 register) is equal to 1. Value in this register is a 'Don't care' when DMBLNK = 0. Applicable to LED output programmed with LDRx = 11 (LEDOUT0 and LEDOUT1 registers).

Blinking period is controlled through 256 linear steps from 00h (41 ms, frequency 24 Hz) to FFh (10.73 s).

$$\text{globalblinkingperiod} = \frac{\text{GFRQ}[7:0] + 1}{24} (\text{s})$$

9.6.1.6 LED Driver Output State Registers (LEDOUT0, LEDOUT1)

Table 9 describes the LED Driver Output State Registers.

Table 9. LEDOUT0 and LEDOUT1 – LED Driver Output State Registers (Address 0Ch and 0Dh) Bit Descriptions

ADDRESS	REGISTER	BIT	SYMBOL	ACCESS ⁽¹⁾	VALUE	DESCRIPTION
0Ch	LEDOUT0	7:6	LDR3[1:0]	R/W	00 ⁽²⁾	LED3 output state control
		5:4	LDR2[1:0]		00 ⁽²⁾	LED2 output state control
		3:2	LDR1[1:0]		00 ⁽²⁾	LED1 output state control
		1:0	LDR0[1:0]		00 ⁽²⁾	LED0 output state control

(1) R = read, W = write

(2) Default value

Table 9. LEDOUT0 and LEDOUT1 – LED Driver Output State Registers (Address 0Ch and 0Dh) Bit Descriptions (continued)

ADDRESS	REGISTER	BIT	SYMBOL	ACCESS ⁽¹⁾	VALUE	DESCRIPTION
0Dh	LEDOUT1	7:6	LDR7[1:0]	R/W	00 ⁽²⁾	LED7 output state control
		5:4	LDR6[1:0]		00 ⁽²⁾	LED6 output state control
		3:2	LDR4[1:0]		00 ⁽²⁾	LED5 output state control
		1:0	LDR4[1:0]		00 ⁽²⁾	LED4 output state control

LDRx = 00 : LED driver x is off (default power-up state).

LDRx = 01 : LED driver x is fully on (individual brightness and group dimming/blinking not controlled).

LDRx = 10 : LED driver x is individual brightness can be controlled through its PWMx register.

LDRx = 11 : LED driver x is individual brightness and group dimming/blinking can be controlled through its PWMx register and the GRPPWM registers.

9.6.1.7 I²C Bus Sub-Address Registers 1 to 3 (SUBADR1–SUBADR3)

Table 10 describes the Output Gain Control Register.

Table 10. SUBADR1–SUBADR3 – I²C Bus Sub-Address Registers 1 to 3 (Addresses 0Eh–10h) Bit Descriptions

ADDRESS	REGISTER	BIT	SYMBOL	ACCESS ⁽¹⁾	VALUE	DESCRIPTION
0Eh	SUBADR1	7:1	A1[7:1]	R/W	1001 001 ⁽²⁾	I ² C bus sub-address 1
		0	A1[0]	R	0 ⁽²⁾	Reserved
0Fh	SUBADR2	7:1	A2[7:1]	R/W	1001 010 ⁽²⁾	I ² C bus sub-address 2
		0	A2[0]	R	0 ⁽²⁾	Reserved
10h	SUBADR3	7:1	A3[7:1]	R/W	1001 100 ⁽²⁾	I ² C bus sub-address 3
		0	A3[0]	R	0 ⁽²⁾	Reserved

(1) R = read, W = write

(2) Default value

Sub-addresses are programmable through the I²C bus. Default power-up values are 92h, 94h, 98h and the device(s) will not acknowledge these addresses right after power-up (the corresponding SUBx bit in MODE1 register is equal to 0).

Once sub-addresses have been programmed to their right values, SUBx bits need to be set to 1 in order to have the device acknowledging these addresses (MODE1 register).

Only the 7 MSBs representing the I²C bus sub-address are valid. The LSB in SUBADRx register is a read-only bit (0).

When SUBx is set to 1, the corresponding I²C bus sub-address can be used during either an I²C bus read or write sequence.

9.6.1.8 LED All Call I²C Bus Address Register (ALLCALLADR)

Table 11 describes the LED All Call I²C Bus Address Register.

Table 11. ALLCALLADR – LED All Call I²C Bus Address Register Addresses 11h) Bit Description

ADDRESS	REGISTER	BIT	SYMBOL	ACCESS ⁽¹⁾	VALUE	DESCRIPTION
11h	ALLCALLADR	7:1	AC[7:1]	R/W	1101 000 ⁽²⁾	ALLCALL I ² C bus address
		0	AC[0]	R	0 ⁽²⁾	Reserved

(1) R = read, W = write

(2) Default value

TLC59208F

SCLS715A – MARCH 2009 – REVISED NOVEMBER 2015

www.ti.com

The LED All Call I²C bus address allows all the TLC59208Fs in the bus to be programmed at the same time (ALLCALL bit in register MODE1 must be equal to 1 (power-up default state)). This address is programmable through the I²C-bus and can be used during either an I²C bus read or write sequence. The register address can also be programmed as a Sub Call.

Only the 7 MSBs representing the All Call I²C bus address are valid. The LSB in ALLCALLADR register is a read-only bit (0).

If ALLCALL bit = 0, the device does not acknowledge the address programmed in register ALLCALLADR.

10 Application and Implementation

NOTE

Information in the following applications sections is not part of the TI component specification, and TI does not warrant its accuracy or completeness. TI's customers are responsible for determining suitability of components for their purposes. Customers should validate and test their design implementation to confirm system functionality.

10.1 Application Information

10.1.1 Setting LED Current

The LED current is primarily dependent on the supply voltage, the forward voltage of the LED, and the series resistor (R_{SET}). In many applications the supply voltage and LED forward voltage cannot be adjusted. Hence, R_{SET} is utilized to adjust the LED current. This calculation is discussed in detail in the typical application example.

10.1.2 PWM Brightness Dimming

The perceived brightness of the LEDs can be adjusted by use of PWM dimming. For example, an LED driven at 50% duty cycle will appear less bright than it would at 100% duty cycle. The TLC59208F offers duty cycle control for each individual channel and also offers group duty cycle control. Refer to the Register Map for details regarding programmable duty cycle.

10.2 Typical Application

This application example provides guidance on how to set the LED current using the TLC59208F.

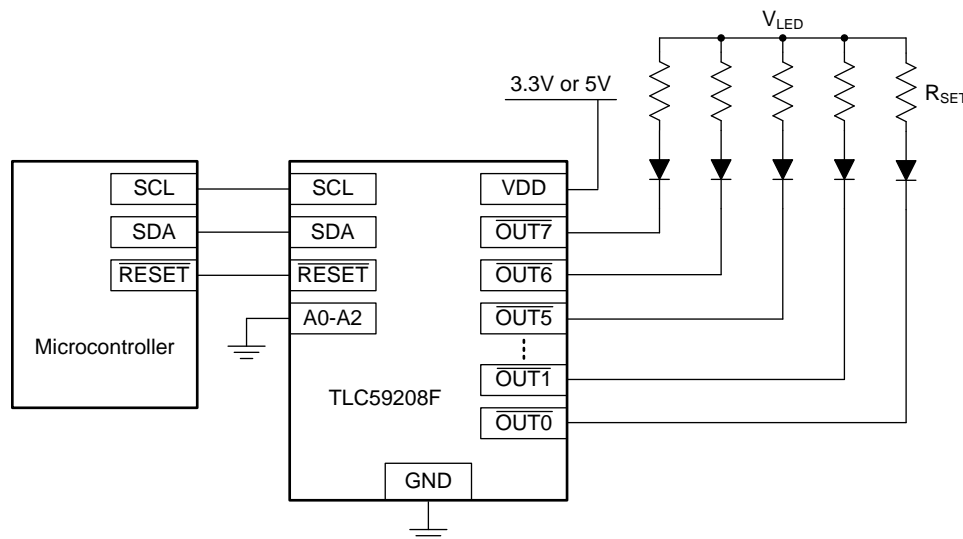

Figure 20. Typical Application

10.2.1 Design Requirements

For this design example, use [Table 12](#) the following as the input parameters.

Table 12. Design Parameters

DESIGN PARAMETER	EXAMPLE VALUE
V_{LED}	Supply voltage that powers the LED
V_F	Forward voltage across the LED
I_{LED}	Current flowing through the LED
R_{ON}	Resistance across open-drain output

10.2.2 Detailed Design Procedure

In the LED current path, there are three voltage drops that must be considered:

- Drop across the series resistor (V_{RSET})
- Drop across the LED (V_F)
- Drop across the open-drain output channel (V_O)

The drop across the LED is defined above as $V_F = 3\text{ V}$. The drop across the open-drain output is calculated as $R_{ON} \times I_{LED}$ ($1.5 \times 0.006 = 0.009\text{ V}$). The remaining voltage must be across the series resistor:

$$5\text{ V} = 3\text{ V} + 0.009\text{ V} + V_{RSET} \quad (1)$$

$$V_{RSET} = 1.991\text{ V} \quad (2)$$

After calculating V_{RSET} , we can calculate R_{SET} :

$$V_{RSET} = I_{LED} \times R_{SET} \quad (3)$$

$$1.991\text{ V} = 0.006\text{ mA} \times R_{SET} \quad (4)$$

$$R_{SET} = 332\ \Omega \quad (5)$$

10.2.3 Application Curve

The following graph shows the typical LED Current as a function of R_{SET} and V_F . The graph assumes that $V_{LED} = 5\text{ V}$.

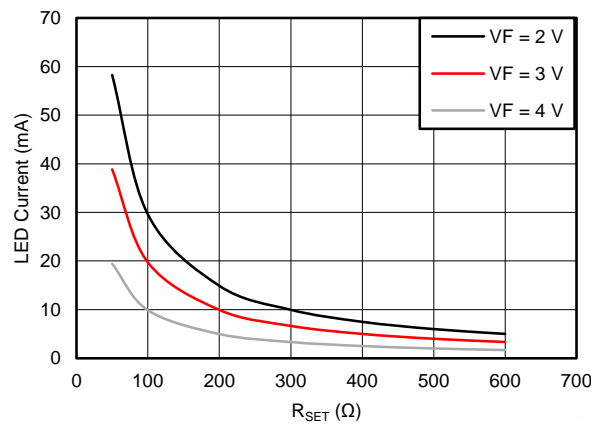

Figure 21. LED Current vs R_{SET}

11 Power Supply Recommendations

TLC59208F operates from a V_{CC} range of 3 V to 5.5 V. The system will also require a power supply for the LEDs. The supply voltage for the LEDs must be greater than the forward voltage of the LED plus the V_{OL} of the channel.

12 Layout

12.1 Layout Guidelines

The I²C signals (SDA / SCL) should be kept away from potential noise sources.

The traces carrying power through the LEDs should be wide enough to handle the necessary current.

All LED current passes through the device and into the ground node. There must be a strong connection between the device ground and the circuit board ground. For the RGY package, the thermal pad should be connected to ground to help dissipate heat.

12.2 Layout Example

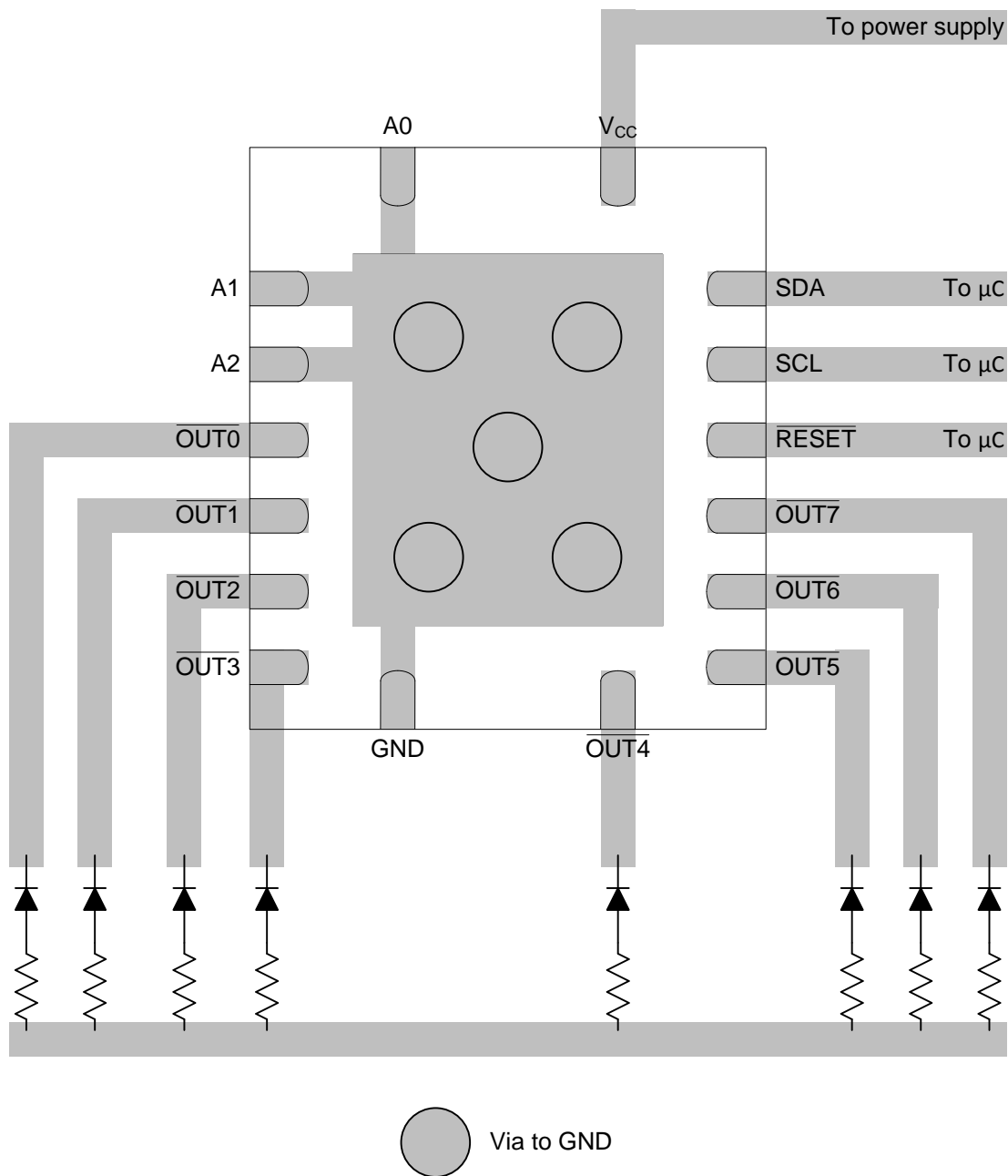

Figure 22. RGY Layout Example

Layout Example (continued)

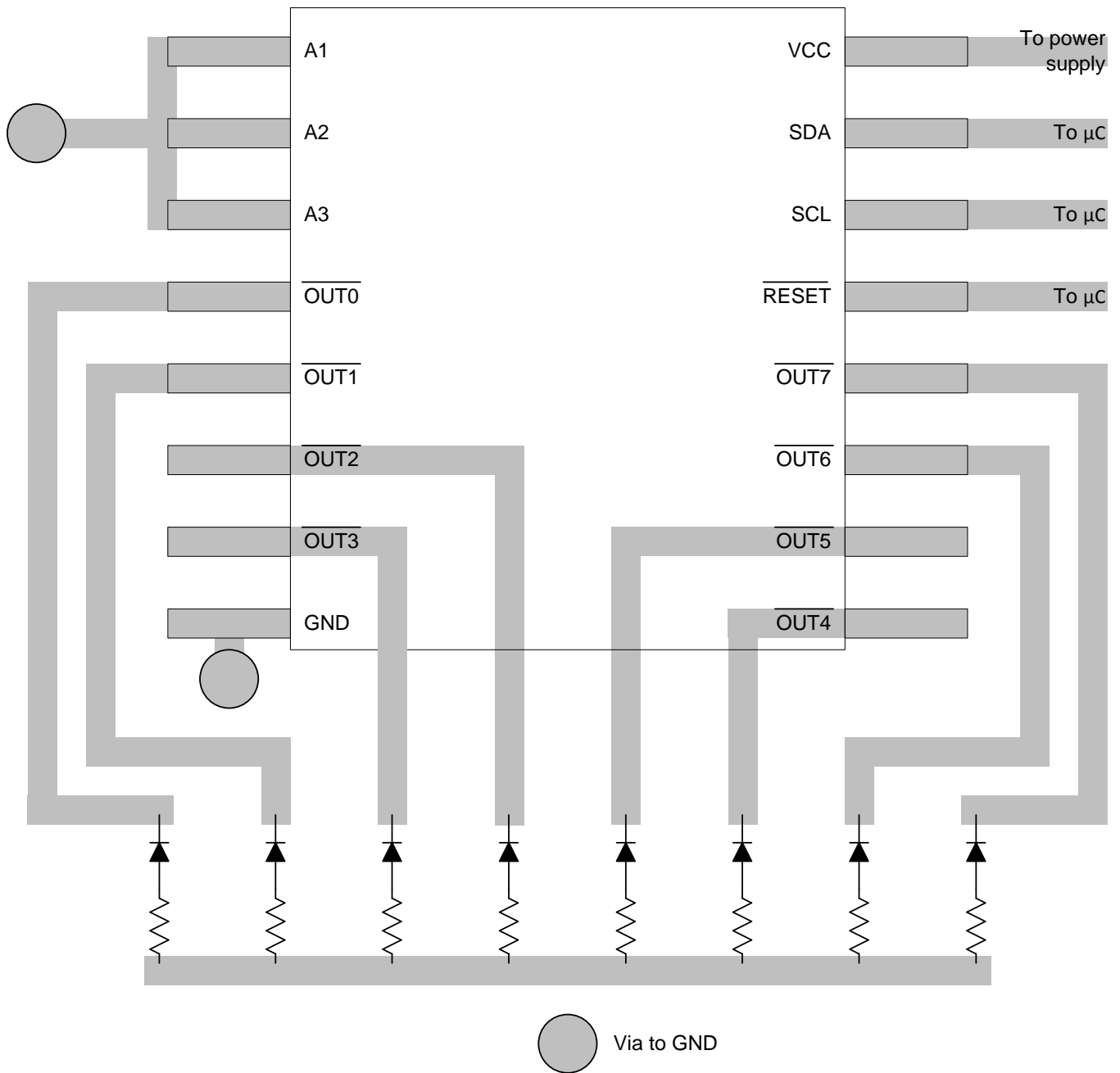

Figure 23. PW Layout Example

13 Device and Documentation Support

13.1 Trademarks

E2E is a trademark of Texas Instruments.
All other trademarks are the property of their respective owners.

13.2 Community Resources

The following links connect to TI community resources. Linked contents are provided "AS IS" by the respective contributors. They do not constitute TI specifications and do not necessarily reflect TI's views; see TI's [Terms of Use](#).

TI E2E™ Online Community *TI's Engineer-to-Engineer (E2E) Community*. Created to foster collaboration among engineers. At e2e.ti.com, you can ask questions, share knowledge, explore ideas and help solve problems with fellow engineers.

Design Support *TI's Design Support* Quickly find helpful E2E forums along with design support tools and contact information for technical support.

13.3 Electrostatic Discharge Caution



These devices have limited built-in ESD protection. The leads should be shorted together or the device placed in conductive foam during storage or handling to prevent electrostatic damage to the MOS gates.

13.4 Glossary

[SLYZ022](#) — *TI Glossary*.

This glossary lists and explains terms, acronyms, and definitions.

14 Mechanical, Packaging, and Orderable Information

The following pages include mechanical, packaging, and orderable information. This information is the most current data available for the designated devices. This data is subject to change without notice and revision of this document. For browser-based versions of this data sheet, refer to the left-hand navigation.

TAPE AND REEL INFORMATION



QUADRANT ASSIGNMENTS FOR PIN 1 ORIENTATION IN TAPE



*All dimensions are nominal

Device	Package Type	Package Drawing	Pins	SPQ	Reel Diameter (mm)	Reel Width W1 (mm)	A0 (mm)	B0 (mm)	K0 (mm)	P1 (mm)	W (mm)	Pin1 Quadrant
TLC59208FIPWR	TSSOP	PW	16	2000	330.0	12.4	6.9	5.6	1.6	8.0	12.0	Q1
TLC59208FIRGYR	VQFN	RGY	16	2500	330.0	12.4	3.8	4.3	1.5	8.0	12.0	Q1

TAPE AND REEL BOX DIMENSIONS

*All dimensions are nominal

Device	Package Type	Package Drawing	Pins	SPQ	Length (mm)	Width (mm)	Height (mm)
TLC59208FIPWR	TSSOP	PW	16	2000	367.0	367.0	35.0
TLC59208FIRGYR	VQFN	RGY	16	2500	367.0	367.0	35.0

PW (R-PDSO-G16)

PLASTIC SMALL OUTLINE

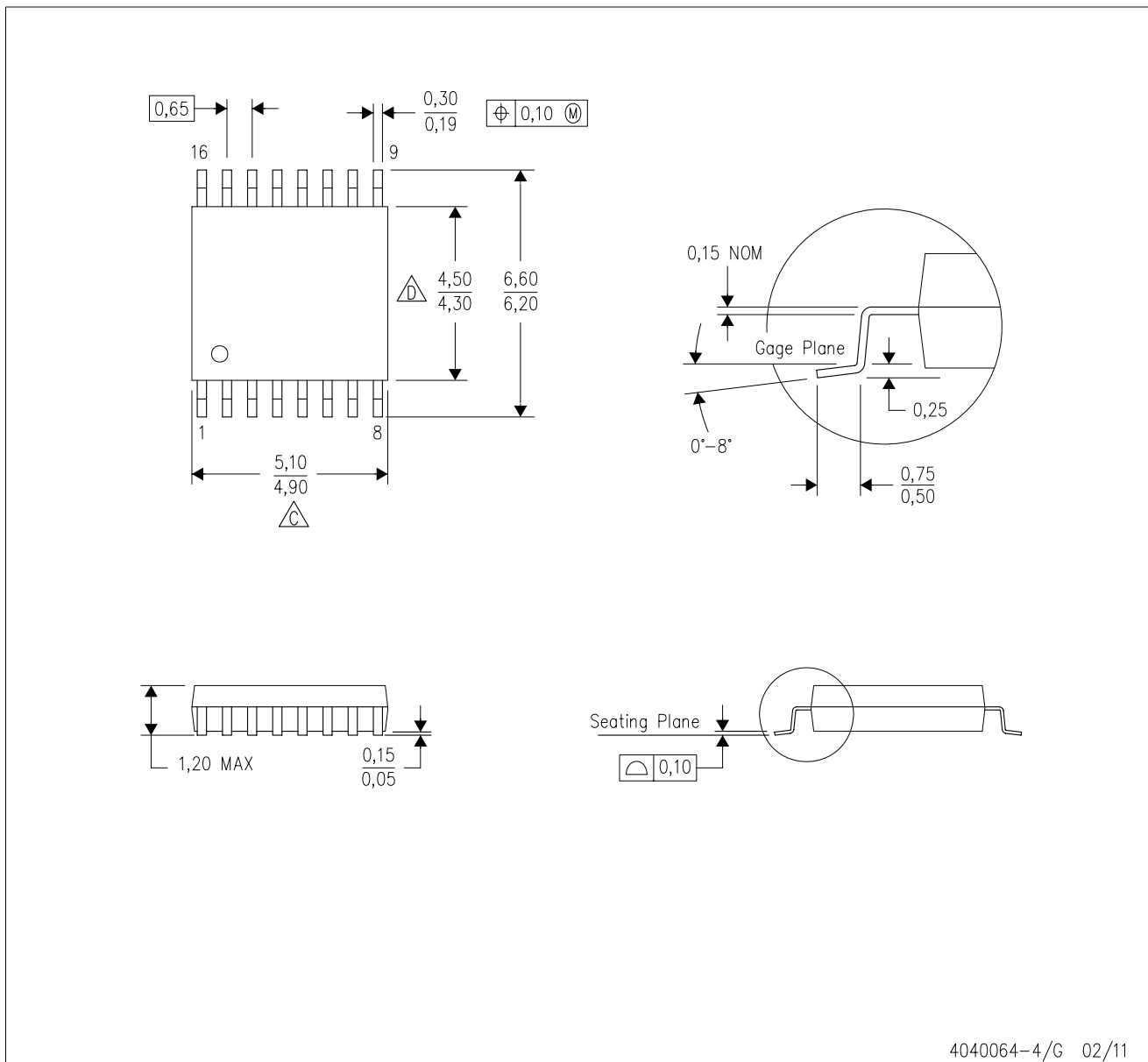

4040064-4/G 02/11

- NOTES:
- A. All linear dimensions are in millimeters. Dimensioning and tolerancing per ASME Y14.5M-1994.
 - B. This drawing is subject to change without notice.
 - C. Body length does not include mold flash, protrusions, or gate burrs. Mold flash, protrusions, or gate burrs shall not exceed 0,15 each side.
 - D. Body width does not include interlead flash. Interlead flash shall not exceed 0,25 each side.
 - E. Falls within JEDEC MO-153

PW (R-PDSO-G16)

PLASTIC SMALL OUTLINE

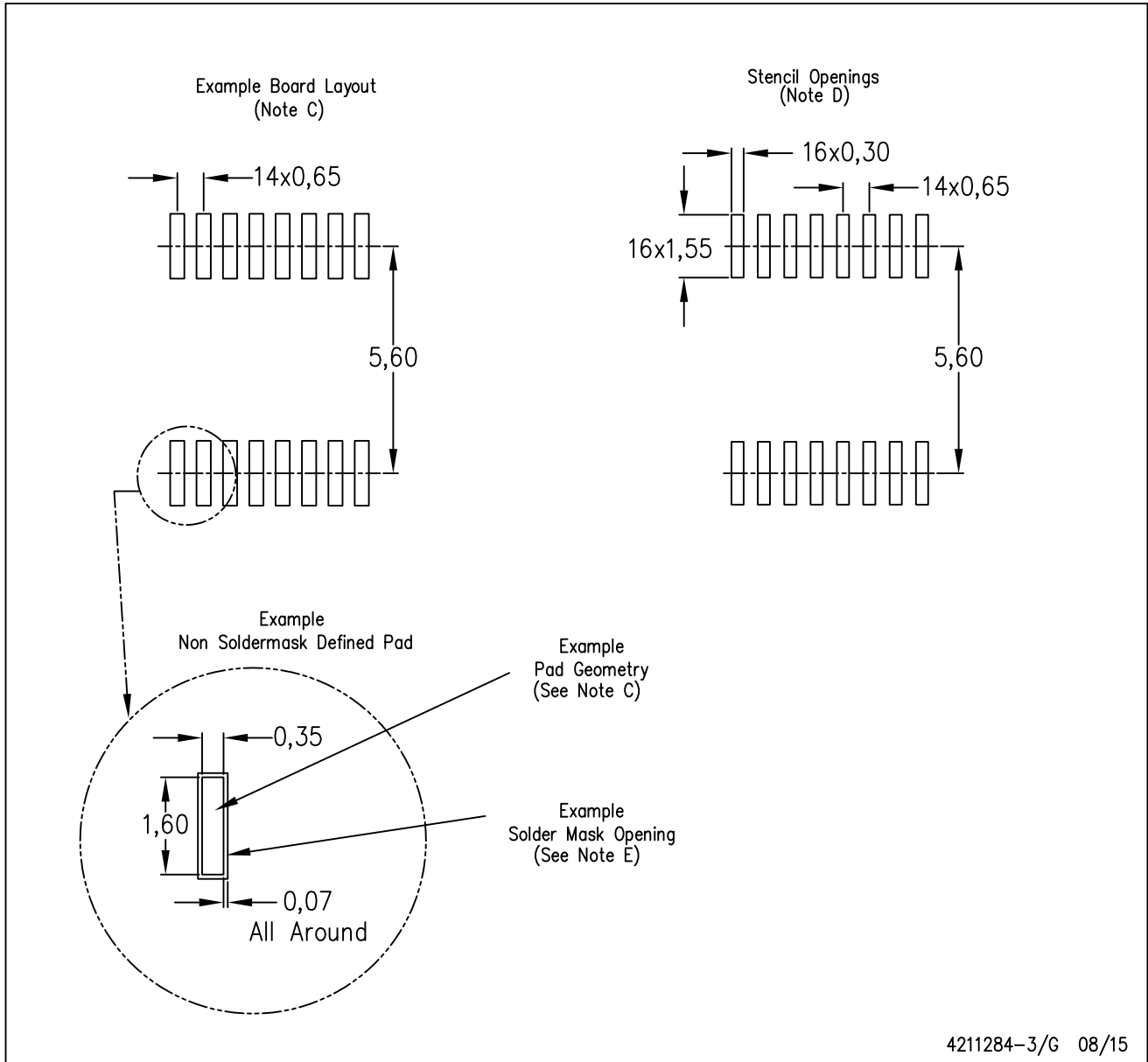

- NOTES:
- All linear dimensions are in millimeters.
 - This drawing is subject to change without notice.
 - Publication IPC-7351 is recommended for alternate designs.
 - Laser cutting apertures with trapezoidal walls and also rounding corners will offer better paste release. Customers should contact their board assembly site for stencil design recommendations. Refer to IPC-7525 for other stencil recommendations.
 - Customers should contact their board fabrication site for solder mask tolerances between and around signal pads.

RGY (R-PVQFN-N16)

PLASTIC QUAD FLATPACK NO-LEAD

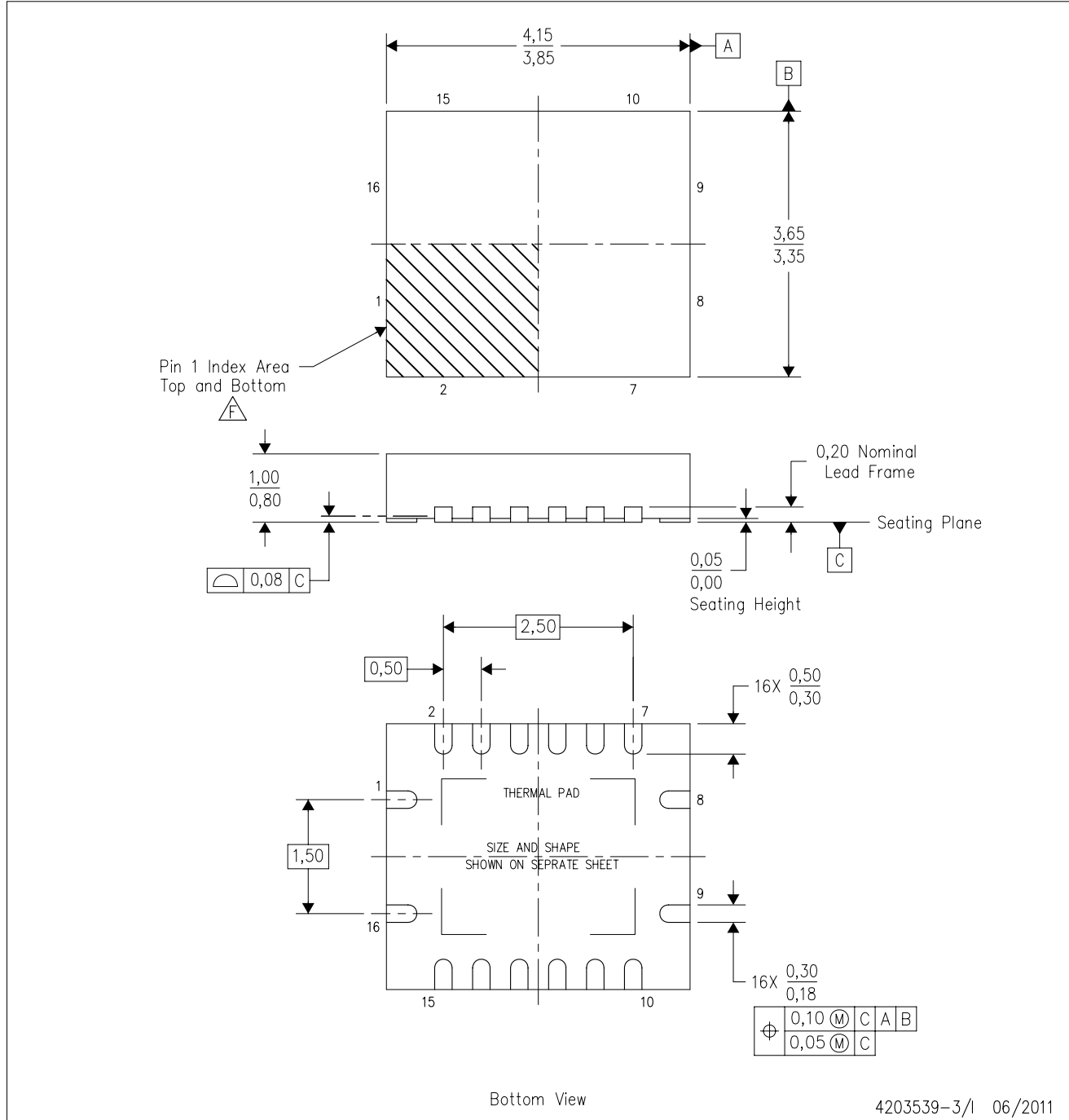

- NOTES:
- A. All linear dimensions are in millimeters. Dimensioning and tolerancing per ASME Y14.5M-1994.
 - B. This drawing is subject to change without notice.
 - C. QFN (Quad Flatpack No-Lead) package configuration.
 - D. The package thermal pad must be soldered to the board for thermal and mechanical performance.
 - E. See the additional figure in the Product Data Sheet for details regarding the exposed thermal pad features and dimensions.
 - △ Pin 1 identifiers are located on both top and bottom of the package and within the zone indicated. The Pin 1 identifiers are either a molded, marked, or metal feature.
 - G. Package complies to JEDEC MO-241 variation BA.

RGY (R-PVQFN-N16)

PLASTIC QUAD FLATPACK NO-LEAD

THERMAL INFORMATION

This package incorporates an exposed thermal pad that is designed to be attached directly to an external heatsink. The thermal pad must be soldered directly to the printed circuit board (PCB). After soldering, the PCB can be used as a heatsink. In addition, through the use of thermal vias, the thermal pad can be attached directly to the appropriate copper plane shown in the electrical schematic for the device, or alternatively, can be attached to a special heatsink structure designed into the PCB. This design optimizes the heat transfer from the integrated circuit (IC).

For information on the Quad Flatpack No-Lead (QFN) package and its advantages, refer to Application Report, QFN/SON PCB Attachment, Texas Instruments Literature No. SLUA271. This document is available at www.ti.com.

The exposed thermal pad dimensions for this package are shown in the following illustration.

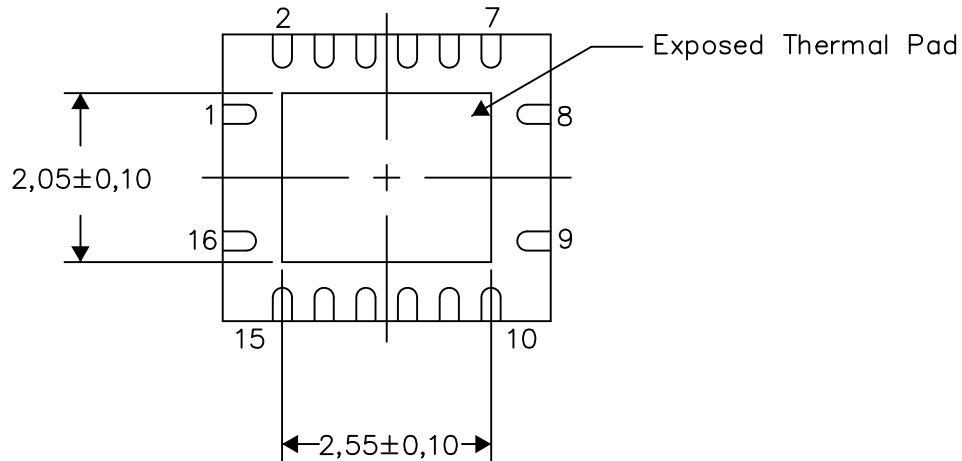

Bottom View

Exposed Thermal Pad Dimensions

4206353-3/P 03/14

NOTE: All linear dimensions are in millimeters

RGY (R-PVQFN-N16)

PLASTIC QUAD FLATPACK NO-LEAD

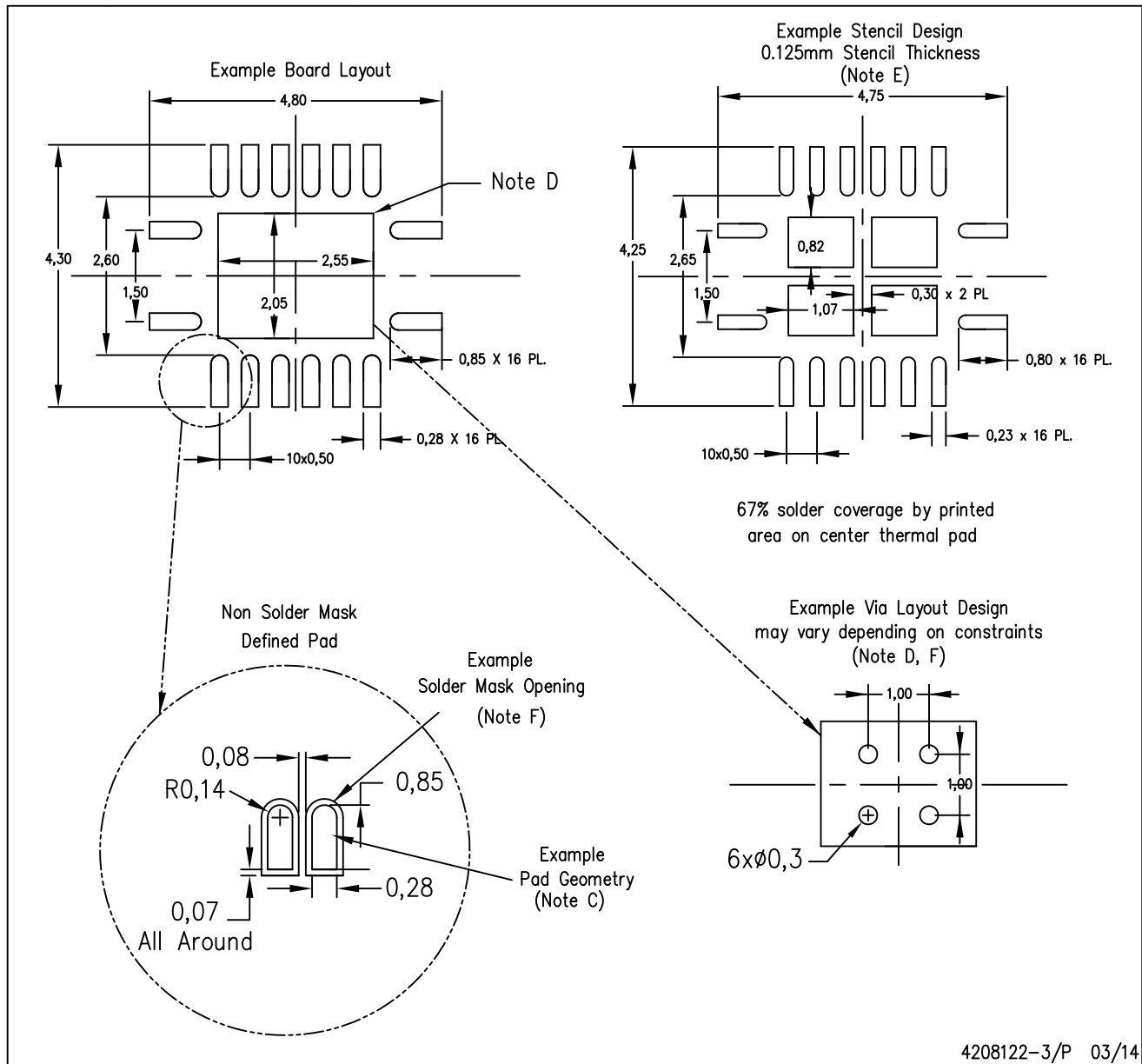

- NOTES:
- A. All linear dimensions are in millimeters.
 - B. This drawing is subject to change without notice.
 - C. Publication IPC-7351 is recommended for alternate designs.
 - D. This package is designed to be soldered to a thermal pad on the board. Refer to Application Note, Quad Flat-Pack QFN/SON PCB Attachment, Texas Instruments Literature No. SLUA271, and also the Product Data Sheets for specific thermal information, via requirements, and recommended board layout. These documents are available at www.ti.com <<http://www.ti.com>>.
 - E. Laser cutting apertures with trapezoidal walls and also rounding corners will offer better paste release. Customers should contact their board assembly site for stencil design recommendations. Refer to IPC 7525 for stencil design considerations.
 - F. Customers should contact their board fabrication site for minimum solder mask web tolerances between signal pads.

IMPORTANT NOTICE

Texas Instruments Incorporated and its subsidiaries (TI) reserve the right to make corrections, enhancements, improvements and other changes to its semiconductor products and services per JESD46, latest issue, and to discontinue any product or service per JESD48, latest issue. Buyers should obtain the latest relevant information before placing orders and should verify that such information is current and complete. All semiconductor products (also referred to herein as "components") are sold subject to TI's terms and conditions of sale supplied at the time of order acknowledgment.

TI warrants performance of its components to the specifications applicable at the time of sale, in accordance with the warranty in TI's terms and conditions of sale of semiconductor products. Testing and other quality control techniques are used to the extent TI deems necessary to support this warranty. Except where mandated by applicable law, testing of all parameters of each component is not necessarily performed.

TI assumes no liability for applications assistance or the design of Buyers' products. Buyers are responsible for their products and applications using TI components. To minimize the risks associated with Buyers' products and applications, Buyers should provide adequate design and operating safeguards.

TI does not warrant or represent that any license, either express or implied, is granted under any patent right, copyright, mask work right, or other intellectual property right relating to any combination, machine, or process in which TI components or services are used. Information published by TI regarding third-party products or services does not constitute a license to use such products or services or a warranty or endorsement thereof. Use of such information may require a license from a third party under the patents or other intellectual property of the third party, or a license from TI under the patents or other intellectual property of TI.

Reproduction of significant portions of TI information in TI data books or data sheets is permissible only if reproduction is without alteration and is accompanied by all associated warranties, conditions, limitations, and notices. TI is not responsible or liable for such altered documentation. Information of third parties may be subject to additional restrictions.

Resale of TI components or services with statements different from or beyond the parameters stated by TI for that component or service voids all express and any implied warranties for the associated TI component or service and is an unfair and deceptive business practice. TI is not responsible or liable for any such statements.

Buyer acknowledges and agrees that it is solely responsible for compliance with all legal, regulatory and safety-related requirements concerning its products, and any use of TI components in its applications, notwithstanding any applications-related information or support that may be provided by TI. Buyer represents and agrees that it has all the necessary expertise to create and implement safeguards which anticipate dangerous consequences of failures, monitor failures and their consequences, lessen the likelihood of failures that might cause harm and take appropriate remedial actions. Buyer will fully indemnify TI and its representatives against any damages arising out of the use of any TI components in safety-critical applications.

In some cases, TI components may be promoted specifically to facilitate safety-related applications. With such components, TI's goal is to help enable customers to design and create their own end-product solutions that meet applicable functional safety standards and requirements. Nonetheless, such components are subject to these terms.

No TI components are authorized for use in FDA Class III (or similar life-critical medical equipment) unless authorized officers of the parties have executed a special agreement specifically governing such use.

Only those TI components which TI has specifically designated as military grade or "enhanced plastic" are designed and intended for use in military/aerospace applications or environments. Buyer acknowledges and agrees that any military or aerospace use of TI components which have **not** been so designated is solely at the Buyer's risk, and that Buyer is solely responsible for compliance with all legal and regulatory requirements in connection with such use.

TI has specifically designated certain components as meeting ISO/TS16949 requirements, mainly for automotive use. In any case of use of non-designated products, TI will not be responsible for any failure to meet ISO/TS16949.

Products

Audio	www.ti.com/audio
Amplifiers	amplifier.ti.com
Data Converters	dataconverter.ti.com
DLP® Products	www.dlp.com
DSP	dsp.ti.com
Clocks and Timers	www.ti.com/clocks
Interface	interface.ti.com
Logic	logic.ti.com
Power Mgmt	power.ti.com
Microcontrollers	microcontroller.ti.com
RFID	www.ti-rfid.com
OMAP Applications Processors	www.ti.com/omap
Wireless Connectivity	www.ti.com/wirelessconnectivity

Applications

Automotive and Transportation	www.ti.com/automotive
Communications and Telecom	www.ti.com/communications
Computers and Peripherals	www.ti.com/computers
Consumer Electronics	www.ti.com/consumer-apps
Energy and Lighting	www.ti.com/energy
Industrial	www.ti.com/industrial
Medical	www.ti.com/medical
Security	www.ti.com/security
Space, Avionics and Defense	www.ti.com/space-avionics-defense
Video and Imaging	www.ti.com/video

TI E2E Community

e2e.ti.com