

# TLC7701-Q1, TLC7705-Q1, TLC7733-Q1 MICROPOWER SUPPLY VOLTAGE SUPERVISORS

SGLS208A – OCTOBER 2003 – REVISED MAY 2008

- Qualified for Automotive Applications
- Power-On Reset Generator
- Automatic Reset Generation After Voltage Drop
- Precision Voltage Sensor
- Temperature-Compensated Voltage Reference
- Programmable Delay Time by External Capacitor
- Supply Voltage Range . . . 2 V to 6 V
- Defined  $\overline{\text{RESET}}$  Output from  $V_{\text{DD}} \geq 1 \text{ V}$
- Power-Down Control Support for Static RAM With Battery Backup
- Maximum Supply Current of 16  $\mu\text{A}$
- Power Saving Totem-Pole Outputs

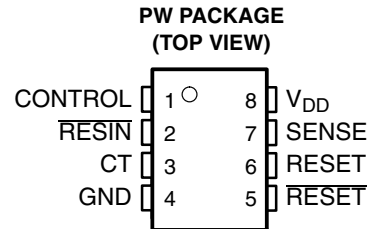

## description

The TLC77xx family of micropower supply voltage supervisors provide reset control, primarily in microcomputer and microprocessor systems.

During power-on,  $\overline{\text{RESET}}$  is asserted when  $V_{\text{DD}}$  reaches 1 V. After minimum  $V_{\text{DD}} (\geq 2 \text{ V})$  is established, the circuit monitors SENSE voltage and keeps the reset outputs active as long as SENSE voltage ( $V_{\text{I(SENSE)}}$ ) remains below the threshold voltage. An internal timer delays return of the output to the inactive state to ensure proper system reset. The delay time,  $t_{\text{d}}$ , is determined by an external capacitor:

$$t_{\text{d}} = 2.1 \times 10^4 \times C_{\text{T}}$$

Where

$C_{\text{T}}$  is in farads

$t_{\text{d}}$  is in seconds

Except for the TLC7701, which can be customized with two external resistors, each supervisor has a fixed SENSE threshold voltage set by an internal voltage divider. When SENSE voltage drops below the threshold voltage, the outputs become active and stay in that state until SENSE voltage returns above threshold voltage and the delay time,  $t_{\text{d}}$ , has expired.

In addition to the power-on-reset and undervoltage-supervisor function, the TLC77xx adds power-down control support for static RAM. When CONTROL is tied to GND, RESET will act as active high. The voltage monitor contains additional logic intended for control of static memories with battery backup during power failure. By driving the chip select ( $\overline{\text{CS}}$ ) of the memory circuit with the RESET output of the TLC77xx and with the CONTROL driven by the memory bank select signal ( $\overline{\text{CSH1}}$ ) of the microprocessor (see Figure 10), the memory circuit is automatically disabled during a power loss. (In this application the TLC77xx power has to be supplied by the battery.)



Please be aware that an important notice concerning availability, standard warranty, and use in critical applications of Texas Instruments semiconductor products and disclaimers thereto appears at the end of this data sheet.

PRODUCTION DATA information is current as of publication date. Products conform to specifications per the terms of Texas Instruments standard warranty. Production processing does not necessarily include testing of all parameters.

 **TEXAS  
INSTRUMENTS**

POST OFFICE BOX 655303 • DALLAS, TEXAS 75265

Copyright © 2008, Texas Instruments Incorporated

# TLC7701-Q1, TLC7705-Q1, TLC7733-Q1 MICROPOWER SUPPLY VOLTAGE SUPERVISORS

SGLS208A – OCTOBER 2003 – REVISED MAY 2008

## ORDERING INFORMATION†‡

T <sub>A</sub>	PACKAGE§		ORDERABLE PART NUMBER	TOP-SIDE MARKING
-40°C to 125°C	TSSOP – PW	Tape and reel	TLC7701QPWRQ1	7701Q1
	TSSOP – PW	Tape and reel	TLC7705QPWRQ1	7705Q1
	TSSOP – PW	Tape and reel	TLC7733QPWRQ1	7733Q1

† For the most current package and ordering information, see the Package Option Addendum at the end of this document, or see the TI web site at <http://www.ti.com>.

‡ Package drawings, thermal data, and symbolization are available at <http://www.ti.com/packaging>.

§ The PW package is only available left-end taped and reeled (indicated by the R suffix on the device type; e.g., TLC7701QPWREP).

## FUNCTION TABLE

CONTROL	RESIN	V <sub>I(SENSE)</sub> > V <sub>IT+</sub>	RESET	RESET
L	L	False	H	L
L	L	True	H	L
L	H	False	H	L
L	H	True	L§	H§
H	L	False	H	L
H	L	True	H	L
H	H	False	H	L
H	H	True	H	H§

§ RESET and RESET states shown are valid for  $t > t_d$ .

## logic symbol¶

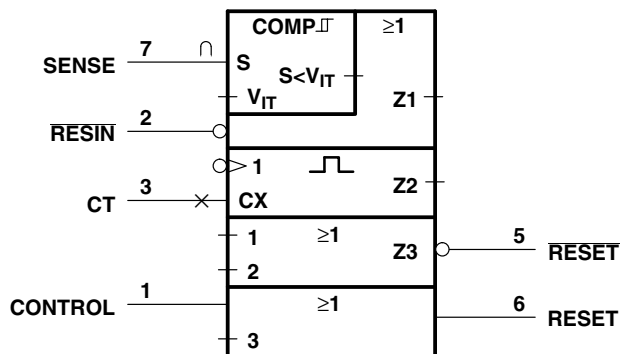

¶ This symbol is in accordance with ANSI/IEEE Std 91-1984 and IEC Publication 617-12.

# TLC7701-Q1, TLC7705-Q1, TLC7733-Q1 MICROPOWER SUPPLY VOLTAGE SUPERVISORS

SGLS208A – OCTOBER 2003 – REVISED MAY 2008

## functional block diagram

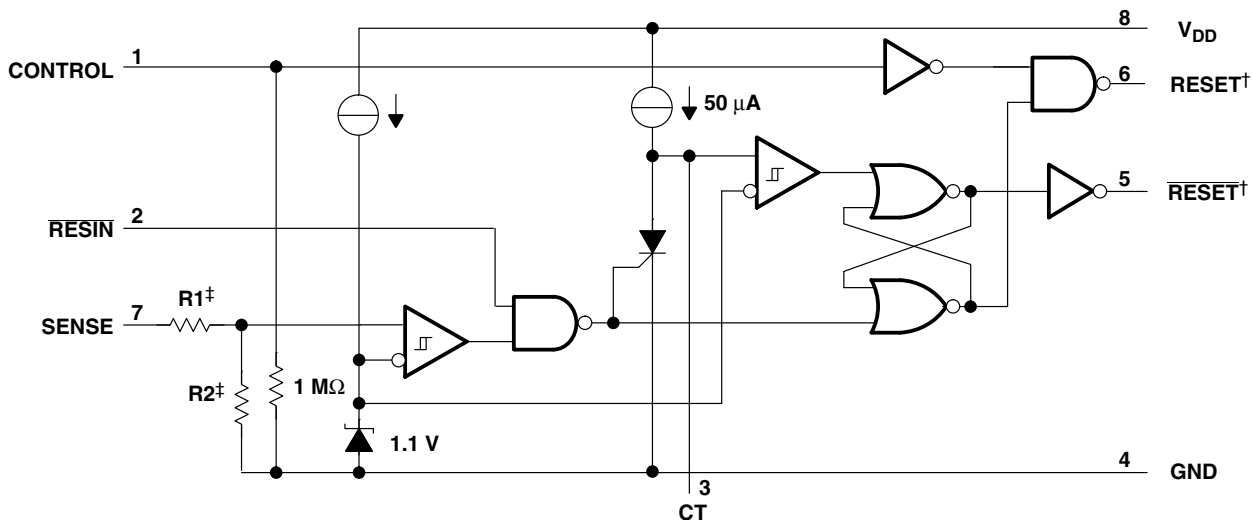

† Outputs are totem-pole configuration. External pullup or pulldown resistors are not required.

‡ Nominal values:

	R1 (Typ)	R2 (Typ)
TLC7701	0	∞
TLC7705	910 kΩ	290 kΩ
TLC7733	750 kΩ	450 kΩ

# TLC7701-Q1, TLC7705-Q1, TLC7733-Q1 MICROPOWER SUPPLY VOLTAGE SUPERVISORS

SGLS208A – OCTOBER 2003 – REVISED MAY 2008

## timing diagram

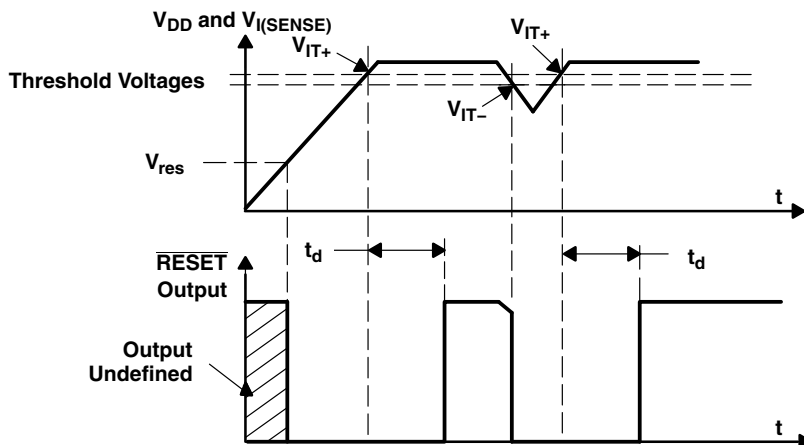

## absolute maximum ratings over operating free-air temperature (unless otherwise noted)<sup>†</sup>

Supply voltage, $V_{DD}$ (see Note 1)	7 V
Input voltage range, CONTROL, $\overline{RESIN}$ , SENSE (see Note 1)	-0.3 V to 7 V
Maximum low output current, $I_{OL}$	10 mA
Maximum high output current, $I_{OH}$	-10 mA
Input clamp current, $I_{IK}$ ( $V_I < 0$ or $V_I > V_{DD}$ )	$\pm 10$ mA
Output clamp current, $I_{OK}$ ( $V_O < 0$ or $V_O > V_{DD}$ )	$\pm 10$ mA
Continuous total power dissipation	See Dissipation Rating Table
Operating free-air temperature range, $T_A$ : TL77xxQ	-40°C to 125°C
Storage temperature range, $T_{stg}$	-65°C to 150°C

<sup>†</sup> Stresses beyond those listed under "absolute maximum ratings" may cause permanent damage to the device. These are stress ratings only, and functional operation of the device at these or any other conditions beyond those indicated under "recommended operating conditions" is not implied. Exposure to absolute-maximum-rated conditions for extended periods may affect device reliability.

NOTE 1: All voltage values are with respect to GND.

DISSIPATION RATING TABLE

PACKAGE	$T_A \leq 25^\circ\text{C}$ POWER RATING	DERATING FACTOR ABOVE $T_A = 25^\circ\text{C}$	$T_A = 85^\circ\text{C}$ POWER RATING	$T_A = 125^\circ\text{C}$ POWER RATING
PW	525 mW	4.2 mW/°C	273 mW	105 mW

## recommended operating conditions at specified temperature range

	MIN	MAX	UNIT
Supply voltage, $V_{DD}$	2	6	V
Input voltage, $V_I$	0	$V_{DD}$	V
High-level input voltage at $\overline{RESIN}$ and CONTROL <sup>‡</sup> , $V_{IH}$	$0.7 \times V_{DD}$		V
Low-level input voltage at $\overline{RESIN}$ and CONTROL <sup>‡</sup> , $V_{IL}$		$0.2 \times V_{DD}$	V
High-level output current, $I_{OH}$		-2	mA
Low-level output current, $I_{OL}$	$V_{DD} \geq 2.7$ V	2	mA
Input transition rise and fall rate at $\overline{RESIN}$ and CONTROL, $\Delta t/\Delta V$		100	ns/V
Operating free-air temperature range, $T_A$	-40	125	°C

<sup>‡</sup> To ensure a low supply current,  $V_{IL}$  should be kept  $< 0.3$  V and  $V_{IH} > V_{DD} - 0.3$  V.



POST OFFICE BOX 655303 • DALLAS, TEXAS 75265

# TLC7701-Q1, TLC7705-Q1, TLC7733-Q1 MICROPOWER SUPPLY VOLTAGE SUPERVISORS

SGLS208A – OCTOBER 2003 – REVISED MAY 2008

electrical characteristics over recommended operating conditions (see Note 2) (unless otherwise noted)

PARAMETER		TEST CONDITIONS	TLC77xx			UNIT	
			MIN	TYP†	MAX		
V <sub>OH</sub>	High-level output voltage	I <sub>OH</sub> = -20 μA	V <sub>DD</sub> = 2 V	1.8		V	
			V <sub>DD</sub> = 2.7 V	2.5			
			V <sub>DD</sub> = 4.5 V	4.3			
		I <sub>OH</sub> = -2 mA	V <sub>DD</sub> = 4.5 V	3.7			
V <sub>OL</sub>	Low-level output voltage	I <sub>OL</sub> = 20 μA	V <sub>DD</sub> = 2 V	0.2		V	
			V <sub>DD</sub> = 2.7 V	0.2			
			V <sub>DD</sub> = 4.5 V	0.2			
		I <sub>OL</sub> = 2 mA	V <sub>DD</sub> = 4.5 V	0.5			
V <sub>IT-</sub>	Negative-going input threshold voltage, SENSE (see Note 3)	TLC7701	V <sub>DD</sub> = 2 V to 6 V	1.04	1.1	1.16	V
		TLC7705		4.43	4.5	4.63	
		TLC7733		2.855	2.93	3.03	
V <sub>hys</sub>	Hysteresis voltage, SENSE	TLC7701	V <sub>DD</sub> = 2 V to 6 V	30		mV	
		TLC7705		70			
		TLC7733					
V <sub>res</sub>	Power-up reset voltage‡	I <sub>OL</sub> = 20 μA			1	V	
I <sub>I</sub>	Input current	RESIN	V <sub>I</sub> = 0 V to V <sub>DD</sub>			2	μA
		CONTROL	V <sub>I</sub> = V <sub>DD</sub>		7	15	
		SENSE	V <sub>I</sub> = 5 V		5	10	
		SENSE, TLC7701 only	V <sub>I</sub> = 5 V			2	
I <sub>DD</sub>	Supply current	RESIN = V <sub>DD</sub> , SENSE = V <sub>DD</sub> ≥ V <sub>ITmax</sub> + 0.2 V CONTROL = 0 V, Outputs open			9	16	μA
I <sub>DD(d)</sub>	Supply current during t <sub>d</sub>	V <sub>DD</sub> = 5 V, V <sub>CT</sub> = 0, RESIN = V <sub>DD</sub> , SENSE = V <sub>DD</sub> , CONTROL = 0 V, Outputs open			120	150	μA
C <sub>I</sub>	Input capacitance, SENSE	V <sub>I</sub> = 0 V to V <sub>DD</sub>			50		pF

† Typical values apply at T<sub>A</sub> = 25°C.

‡ The lowest supply voltage at which RESET becomes active. The symbol V<sub>res</sub> is not currently listed within EIA or JEDEC standards for semiconductor symbology. Rise time of V<sub>DD</sub> ≥ 15 μs/V.

NOTES: 2. All characteristics are measured with C<sub>T</sub> = 0.1 μF.

3. To ensure best stability of the threshold voltage, a bypass capacitor (ceramic, 0.1 μF) should be connected near the supply terminals.



# TLC7701-Q1, TLC7705-Q1, TLC7733-Q1 MICROPOWER SUPPLY VOLTAGE SUPERVISORS

SGLS208A – OCTOBER 2003 – REVISED MAY 2008

switching characteristics at  $V_{DD} = 5\text{ V}$ ,  $R_L = 2\text{ k}\Omega$ ,  $C_L = 50\text{ pF}$ ,  $T_A = \text{Full Range}$  (unless otherwise noted)

PARAMETER	MEASURED		TEST CONDITIONS	TLC77xx			UNIT
	FROM (INPUT)	TO (OUTPUT)		MIN	TYP	MAX	
$t_d$ Delay time	$V_{I(\text{SENSE})} \geq V_{IT+}$	RESET and RESET	$RESIN = 0.7 \times V_{DD}$ , $CONTROL = 0.2 \times V_{DD}$ , $C_T = 100\text{ nF}$ , $T_A = \text{Full range}$ , See timing diagram	1.1	2.1	4.2	ms
$t_{PLH}$ Propagation delay time, low-to-high-level output	SENSE	RESET	$V_{IH} = V_{IT+max} + 0.2\text{ V}$ , $V_{IL} = V_{IT-min} - 0.2\text{ V}$ , $RESIN = 0.7 \times V_{DD}$ , $CONTROL = 0.2 \times V_{DD}$ , $CT = NC^\dagger$	20			$\mu\text{s}$
$t_{PHL}$ Propagation delay time, high-to-low-level output				5			
$t_{PLH}$ Propagation delay time, low-to-high-level output		RESET		5			
$t_{PHL}$ Propagation delay time, high-to-low-level output				20			
$t_{PLH}$ Propagation delay time, low-to-high-level output	RESIN	RESET	$V_{IH} = 0.7 \times V_{DD}$ , $V_{IL} = 0.2 \times V_{DD}$ , $SENSE = V_{IT+max} + 0.2\text{ V}$ , $CONTROL = 0.2 \times V_{DD}$ , $CT = NC^\dagger$	20			$\mu\text{s}$
$t_{PHL}$ Propagation delay time, high-to-low-level output				60			
$t_{PLH}$ Propagation delay time, low-to-high-level output		RESET		65			ns
$t_{PHL}$ Propagation delay time, high-to-low-level output				20			
$t_{PLH}$ Propagation delay time, low-to-high-level output	CONTROL	RESET	$V_{IH} = 0.7 \times V_{DD}$ , $V_{IL} = 0.2 \times V_{DD}$ , $SENSE = V_{IT+max} + 0.2\text{ V}$ , $RESIN = 0.7 \times V_{DD}$ , $CT = NC^\dagger$	58			ns
$t_{PHL}$ Propagation delay time, high-to-low-level output				58			
Low-level minimum pulse duration to switch RESET and RESET	SENSE		$V_{IH} = V_{IT+max} + 0.2\text{ V}$ , $V_{IL} = V_{IT-min} - 0.2\text{ V}$ , $V_{IL} = 0.2 \times V_{DD}$ , $V_{IH} = 0.7 \times V_{DD}$	3			$\mu\text{s}$
	RESIN			1			
$t_r$ Rise time		RESET and RESET	10% to 90%	8			ns/V
$t_f$ Fall time			90% to 10%	4			

$^\dagger$  NC = No capacitor, and includes up to 100-pF probe and jig capacitance.



PARAMETER MEASUREMENT INFORMATION

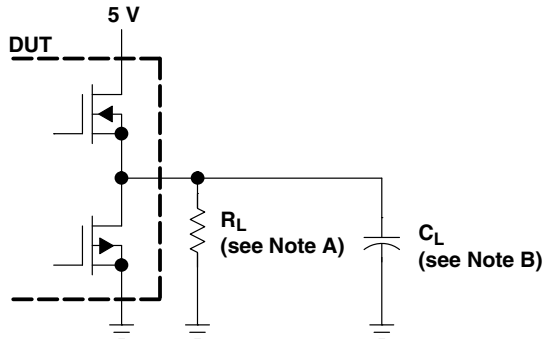

NOTES: A. For switching characteristics,  $R_L = 2\text{ k}\Omega$ .  
B.  $C_L = 50\text{ pF}$  includes jig and probe capacitance.

Figure 1. RESET AND  $\overline{\text{RESET}}$  Output Configurations

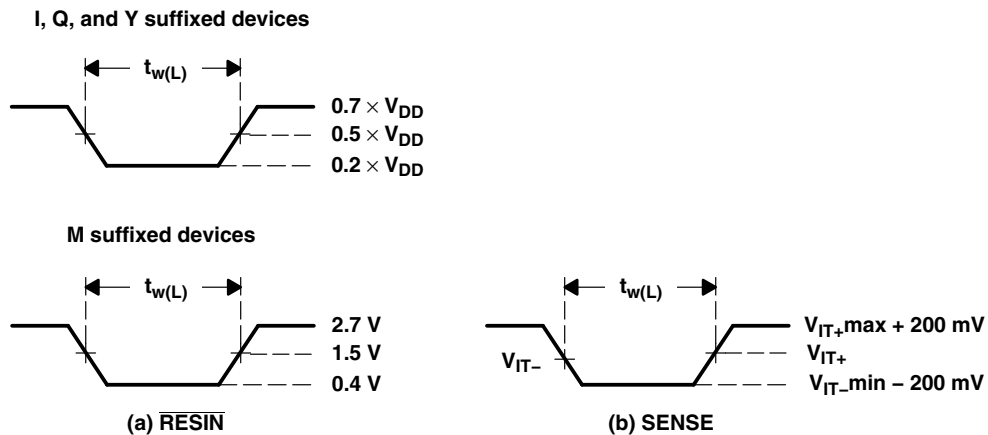

Figure 2. Input Pulse Definition Waveforms

# TLC7701-Q1, TLC7705-Q1, TLC7733-Q1 MICROPOWER SUPPLY VOLTAGE SUPERVISORS

SGLS208A – OCTOBER 2003 – REVISED MAY 2008

## TYPICAL CHARACTERISTICS

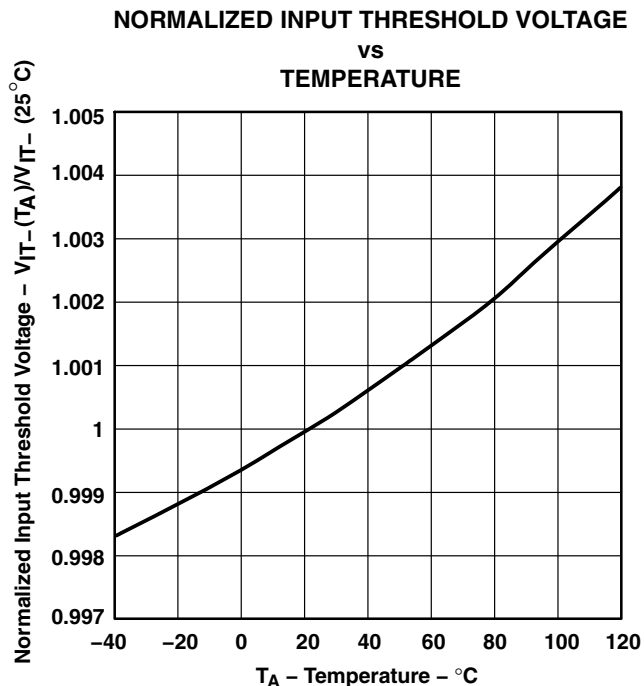

Figure 3

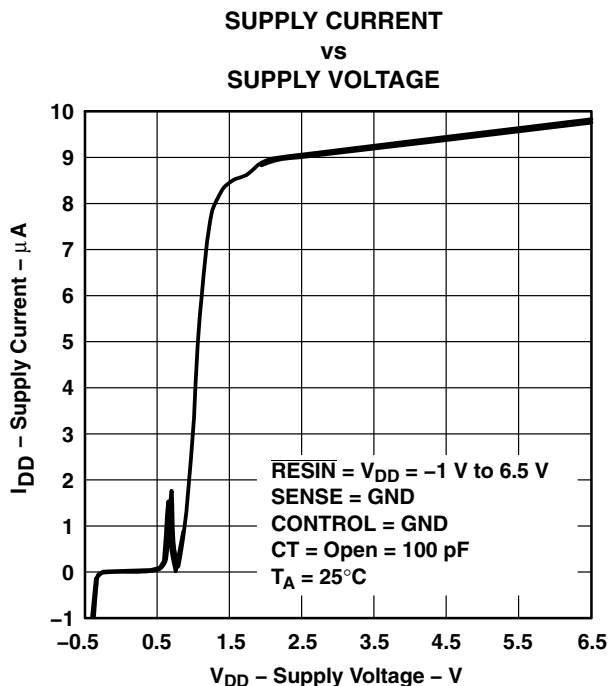

Figure 4

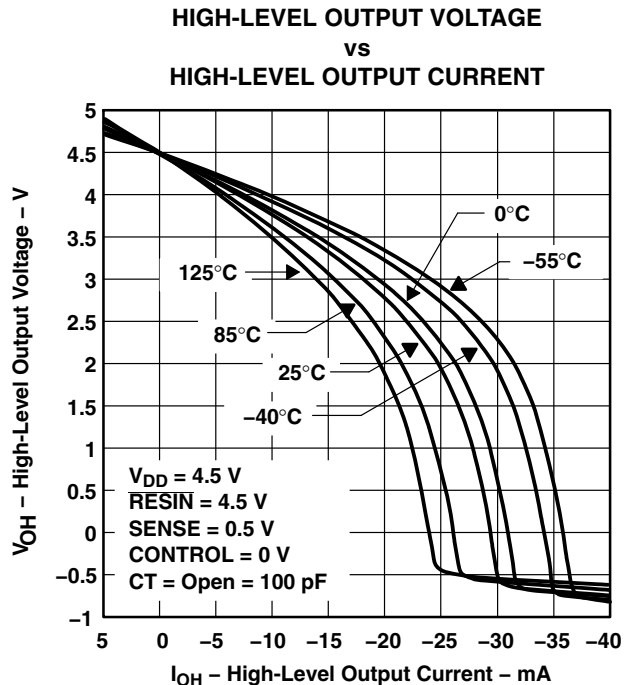

Figure 5

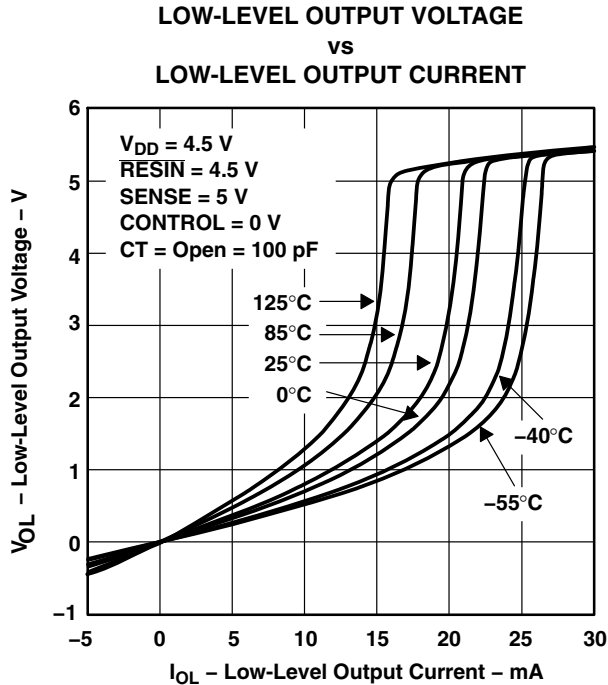
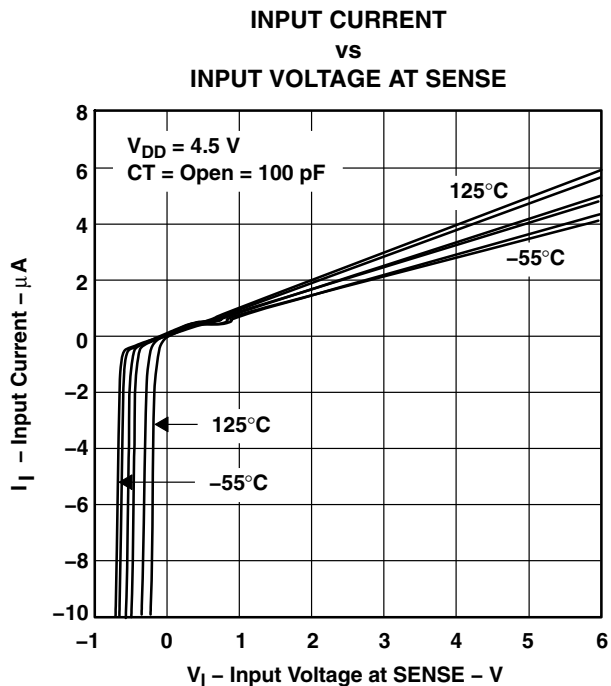

Figure 6



TYPICAL CHARACTERISTICS



**MINIMUM PULSE DURATION AT SENSE  
vs  
SENSE THRESHOLD OVERDRIVE**

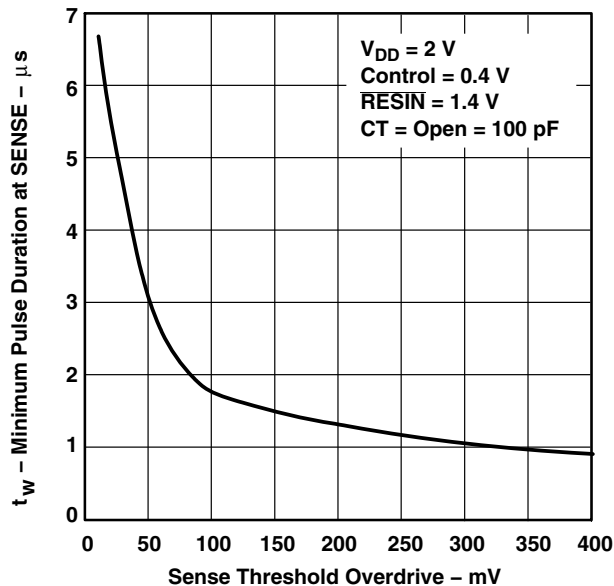

# TLC7701-Q1, TLC7705-Q1, TLC7733-Q1 MICROPOWER SUPPLY VOLTAGE SUPERVISORS

SGLS208A – OCTOBER 2003 – REVISED MAY 2008

## APPLICATION INFORMATION

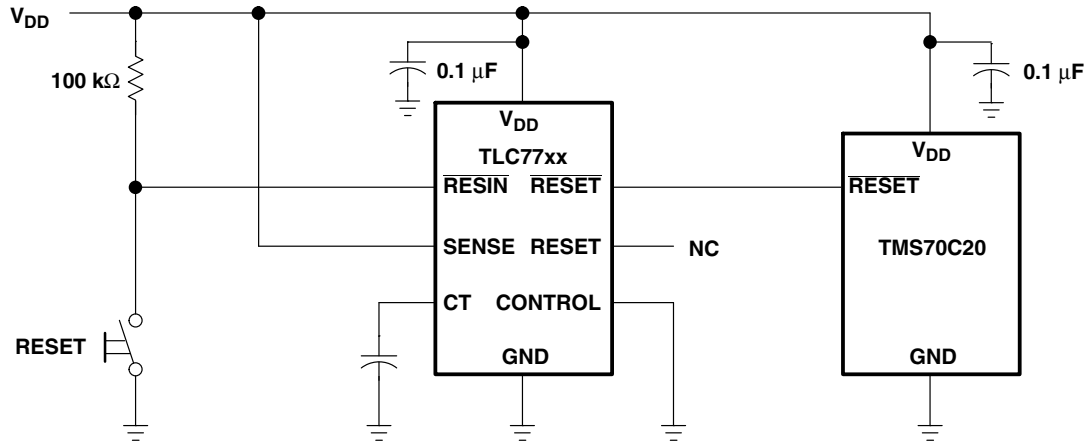

Figure 9. Reset Controller in a Microcomputer System

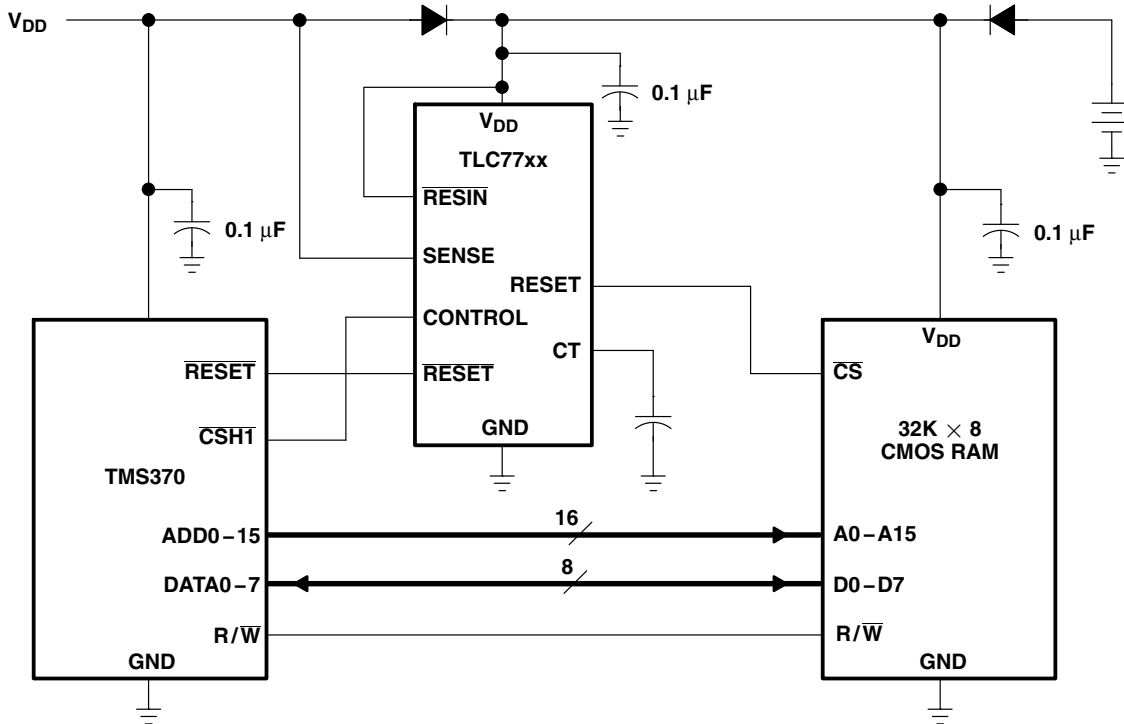

Figure 10. Data Retention During Power Down Using Static CMOS RAMs

## PACKAGING INFORMATION

Orderable Device	Status (1)	Package Type	Package Drawing	Pins	Package Qty	Eco Plan (2)	Lead/Ball Finish	MSL Peak Temp (3)	Op Temp (°C)	Device Marking (4/5)	Samples
TLC7701QPWRG4Q1	ACTIVE	TSSOP	PW	8	2000	Green (RoHS & no Sb/Br)	CU NIPDAU	Level-1-260C-UNLIM	-40 to 125	7701Q1	<a href="#">Samples</a>
TLC7701QPWRQ1	ACTIVE	TSSOP	PW	8	2000	Green (RoHS & no Sb/Br)	CU NIPDAU	Level-1-260C-UNLIM	-40 to 125	7701Q1	<a href="#">Samples</a>
TLC7705QPWRG4Q1	ACTIVE	TSSOP	PW	8	2000	Green (RoHS & no Sb/Br)	CU NIPDAU	Level-1-260C-UNLIM	-40 to 125	7705Q1	<a href="#">Samples</a>
TLC7733QPWRG4Q1	ACTIVE	TSSOP	PW	8	2000	Green (RoHS & no Sb/Br)	CU NIPDAU	Level-1-260C-UNLIM	-40 to 125	7733Q1	<a href="#">Samples</a>
TLC7733QPWRQ1	ACTIVE	TSSOP	PW	8	2000	Green (RoHS & no Sb/Br)	CU NIPDAU	Level-1-260C-UNLIM	-40 to 125	7733Q1	<a href="#">Samples</a>

(1) The marketing status values are defined as follows:

**ACTIVE:** Product device recommended for new designs.

**LIFEBUY:** TI has announced that the device will be discontinued, and a lifetime-buy period is in effect.

**NRND:** Not recommended for new designs. Device is in production to support existing customers, but TI does not recommend using this part in a new design.

**PREVIEW:** Device has been announced but is not in production. Samples may or may not be available.

**OBSOLETE:** TI has discontinued the production of the device.

(2) Eco Plan - The planned eco-friendly classification: Pb-Free (RoHS), Pb-Free (RoHS Exempt), or Green (RoHS & no Sb/Br) - please check <http://www.ti.com/productcontent> for the latest availability information and additional product content details.

**TBD:** The Pb-Free/Green conversion plan has not been defined.

**Pb-Free (RoHS):** TI's terms "Lead-Free" or "Pb-Free" mean semiconductor products that are compatible with the current RoHS requirements for all 6 substances, including the requirement that lead not exceed 0.1% by weight in homogeneous materials. Where designed to be soldered at high temperatures, TI Pb-Free products are suitable for use in specified lead-free processes.

**Pb-Free (RoHS Exempt):** This component has a RoHS exemption for either 1) lead-based flip-chip solder bumps used between the die and package, or 2) lead-based die adhesive used between the die and leadframe. The component is otherwise considered Pb-Free (RoHS compatible) as defined above.

**Green (RoHS & no Sb/Br):** TI defines "Green" to mean Pb-Free (RoHS compatible), and free of Bromine (Br) and Antimony (Sb) based flame retardants (Br or Sb do not exceed 0.1% by weight in homogeneous material)

(3) MSL, Peak Temp. -- The Moisture Sensitivity Level rating according to the JEDEC industry standard classifications, and peak solder temperature.

(4) There may be additional marking, which relates to the logo, the lot trace code information, or the environmental category on the device.

(5) Multiple Device Markings will be inside parentheses. Only one Device Marking contained in parentheses and separated by a "~" will appear on a device. If a line is indented then it is a continuation of the previous line and the two combined represent the entire Device Marking for that device.

**Important Information and Disclaimer:** The information provided on this page represents TI's knowledge and belief as of the date that it is provided. TI bases its knowledge and belief on information provided by third parties, and makes no representation or warranty as to the accuracy of such information. Efforts are underway to better integrate information from third parties. TI has taken and continues to take reasonable steps to provide representative and accurate information but may not have conducted destructive testing or chemical analysis on incoming materials and chemicals. TI and TI suppliers consider certain information to be proprietary, and thus CAS numbers and other limited information may not be available for release.

In no event shall TI's liability arising out of such information exceed the total purchase price of the TI part(s) at issue in this document sold by TI to Customer on an annual basis.

**OTHER QUALIFIED VERSIONS OF TLC7701-Q1, TLC7705-Q1, TLC7733-Q1 :**

- Catalog: [TLC7701](#), [TLC7705](#), [TLC7733](#)
  
- Enhanced Product: [TLC7701-EP](#), [TLC7705-EP](#), [TLC7733-EP](#)
  
- Military: [TLC7705M](#), [TLC7733M](#)

NOTE: Qualified Version Definitions:

- Catalog - TI's standard catalog product
  
- Enhanced Product - Supports Defense, Aerospace and Medical Applications
  
- Military - QML certified for Military and Defense Applications

## TAPE AND REEL INFORMATION



### QUADRANT ASSIGNMENTS FOR PIN 1 ORIENTATION IN TAPE



\*All dimensions are nominal

Device	Package Type	Package Drawing	Pins	SPQ	Reel Diameter (mm)	Reel Width W1 (mm)	A0 (mm)	B0 (mm)	K0 (mm)	P1 (mm)	W (mm)	Pin1 Quadrant
TLC7733QPWRG4Q1	TSSOP	PW	8	2000	330.0	12.4	7.0	3.6	1.6	8.0	12.0	Q1

TAPE AND REEL BOX DIMENSIONS



\*All dimensions are nominal

Device	Package Type	Package Drawing	Pins	SPQ	Length (mm)	Width (mm)	Height (mm)
TLC7733QPWRG4Q1	TSSOP	PW	8	2000	367.0	367.0	35.0

PW0008A



**PACKAGE OUTLINE**  
**TSSOP - 1.2 mm max height**

SMALL OUTLINE PACKAGE

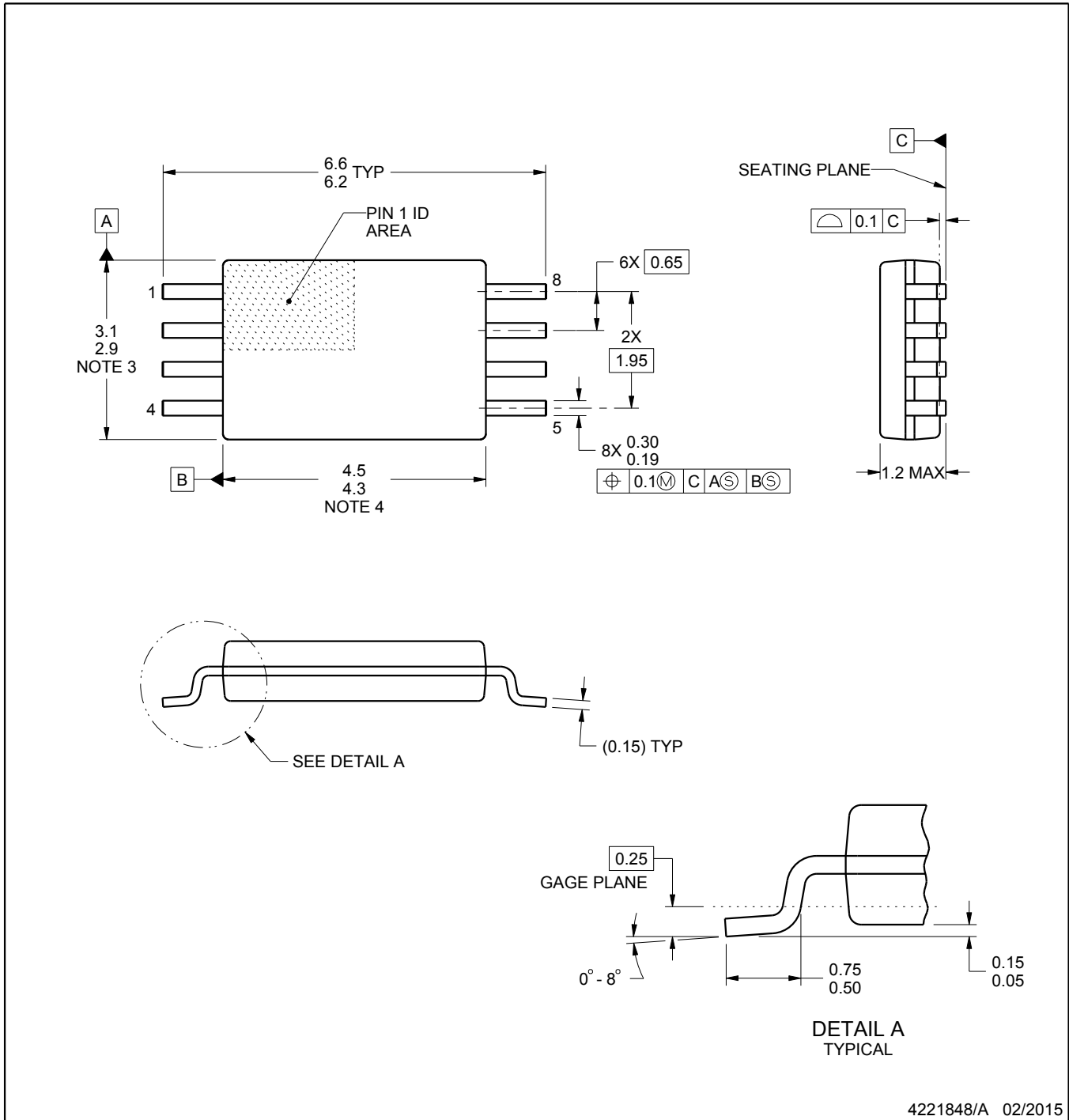

4221848/A 02/2015

NOTES:

1. All linear dimensions are in millimeters. Any dimensions in parenthesis are for reference only. Dimensioning and tolerancing per ASME Y14.5M.
2. This drawing is subject to change without notice.
3. This dimension does not include mold flash, protrusions, or gate burrs. Mold flash, protrusions, or gate burrs shall not exceed 0.15 mm per side.
4. This dimension does not include interlead flash. Interlead flash shall not exceed 0.25 mm per side.
5. Reference JEDEC registration MO-153, variation AA.

# EXAMPLE BOARD LAYOUT

PW0008A

TSSOP - 1.2 mm max height

SMALL OUTLINE PACKAGE

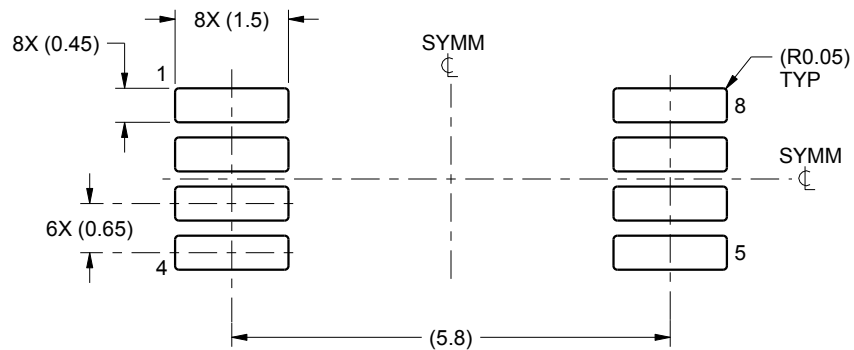

LAND PATTERN EXAMPLE  
SCALE:10X

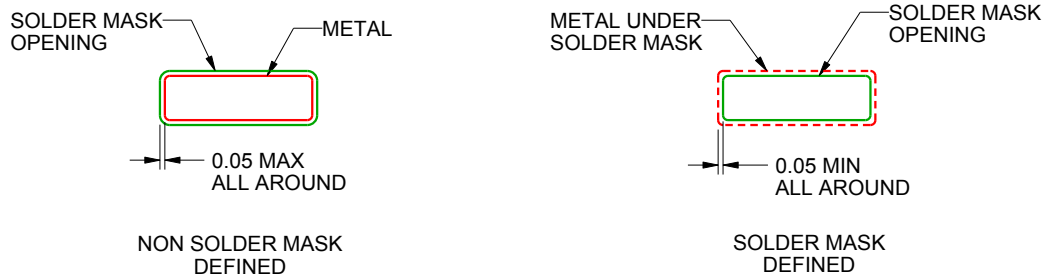

SOLDER MASK DETAILS  
NOT TO SCALE

4221848/A 02/2015

NOTES: (continued)

- 6. Publication IPC-7351 may have alternate designs.
- 7. Solder mask tolerances between and around signal pads can vary based on board fabrication site.

# EXAMPLE STENCIL DESIGN

PW0008A

TSSOP - 1.2 mm max height

SMALL OUTLINE PACKAGE



SOLDER PASTE EXAMPLE  
BASED ON 0.125 mm THICK STENCIL  
SCALE:10X

4221848/A 02/2015

NOTES: (continued)

8. Laser cutting apertures with trapezoidal walls and rounded corners may offer better paste release. IPC-7525 may have alternate design recommendations.
9. Board assembly site may have different recommendations for stencil design.

## IMPORTANT NOTICE

Texas Instruments Incorporated and its subsidiaries (TI) reserve the right to make corrections, enhancements, improvements and other changes to its semiconductor products and services per JESD46, latest issue, and to discontinue any product or service per JESD48, latest issue. Buyers should obtain the latest relevant information before placing orders and should verify that such information is current and complete. All semiconductor products (also referred to herein as "components") are sold subject to TI's terms and conditions of sale supplied at the time of order acknowledgment.

TI warrants performance of its components to the specifications applicable at the time of sale, in accordance with the warranty in TI's terms and conditions of sale of semiconductor products. Testing and other quality control techniques are used to the extent TI deems necessary to support this warranty. Except where mandated by applicable law, testing of all parameters of each component is not necessarily performed.

TI assumes no liability for applications assistance or the design of Buyers' products. Buyers are responsible for their products and applications using TI components. To minimize the risks associated with Buyers' products and applications, Buyers should provide adequate design and operating safeguards.

TI does not warrant or represent that any license, either express or implied, is granted under any patent right, copyright, mask work right, or other intellectual property right relating to any combination, machine, or process in which TI components or services are used. Information published by TI regarding third-party products or services does not constitute a license to use such products or services or a warranty or endorsement thereof. Use of such information may require a license from a third party under the patents or other intellectual property of the third party, or a license from TI under the patents or other intellectual property of TI.

Reproduction of significant portions of TI information in TI data books or data sheets is permissible only if reproduction is without alteration and is accompanied by all associated warranties, conditions, limitations, and notices. TI is not responsible or liable for such altered documentation. Information of third parties may be subject to additional restrictions.

Resale of TI components or services with statements different from or beyond the parameters stated by TI for that component or service voids all express and any implied warranties for the associated TI component or service and is an unfair and deceptive business practice. TI is not responsible or liable for any such statements.

Buyer acknowledges and agrees that it is solely responsible for compliance with all legal, regulatory and safety-related requirements concerning its products, and any use of TI components in its applications, notwithstanding any applications-related information or support that may be provided by TI. Buyer represents and agrees that it has all the necessary expertise to create and implement safeguards which anticipate dangerous consequences of failures, monitor failures and their consequences, lessen the likelihood of failures that might cause harm and take appropriate remedial actions. Buyer will fully indemnify TI and its representatives against any damages arising out of the use of any TI components in safety-critical applications.

In some cases, TI components may be promoted specifically to facilitate safety-related applications. With such components, TI's goal is to help enable customers to design and create their own end-product solutions that meet applicable functional safety standards and requirements. Nonetheless, such components are subject to these terms.

No TI components are authorized for use in FDA Class III (or similar life-critical medical equipment) unless authorized officers of the parties have executed a special agreement specifically governing such use.

Only those TI components which TI has specifically designated as military grade or "enhanced plastic" are designed and intended for use in military/aerospace applications or environments. Buyer acknowledges and agrees that any military or aerospace use of TI components which have **not** been so designated is solely at the Buyer's risk, and that Buyer is solely responsible for compliance with all legal and regulatory requirements in connection with such use.

TI has specifically designated certain components as meeting ISO/TS16949 requirements, mainly for automotive use. In any case of use of non-designated products, TI will not be responsible for any failure to meet ISO/TS16949.

### Products

Audio	<a href="http://www.ti.com/audio">www.ti.com/audio</a>
Amplifiers	<a href="http://amplifier.ti.com">amplifier.ti.com</a>
Data Converters	<a href="http://dataconverter.ti.com">dataconverter.ti.com</a>
DLP® Products	<a href="http://www.dlp.com">www.dlp.com</a>
DSP	<a href="http://dsp.ti.com">dsp.ti.com</a>
Clocks and Timers	<a href="http://www.ti.com/clocks">www.ti.com/clocks</a>
Interface	<a href="http://interface.ti.com">interface.ti.com</a>
Logic	<a href="http://logic.ti.com">logic.ti.com</a>
Power Mgmt	<a href="http://power.ti.com">power.ti.com</a>
Microcontrollers	<a href="http://microcontroller.ti.com">microcontroller.ti.com</a>
RFID	<a href="http://www.ti-rfid.com">www.ti-rfid.com</a>
OMAP Applications Processors	<a href="http://www.ti.com/omap">www.ti.com/omap</a>
Wireless Connectivity	<a href="http://www.ti.com/wirelessconnectivity">www.ti.com/wirelessconnectivity</a>

### Applications

Automotive and Transportation	<a href="http://www.ti.com/automotive">www.ti.com/automotive</a>
Communications and Telecom	<a href="http://www.ti.com/communications">www.ti.com/communications</a>
Computers and Peripherals	<a href="http://www.ti.com/computers">www.ti.com/computers</a>
Consumer Electronics	<a href="http://www.ti.com/consumer-apps">www.ti.com/consumer-apps</a>
Energy and Lighting	<a href="http://www.ti.com/energy">www.ti.com/energy</a>
Industrial	<a href="http://www.ti.com/industrial">www.ti.com/industrial</a>
Medical	<a href="http://www.ti.com/medical">www.ti.com/medical</a>
Security	<a href="http://www.ti.com/security">www.ti.com/security</a>
Space, Avionics and Defense	<a href="http://www.ti.com/space-avionics-defense">www.ti.com/space-avionics-defense</a>
Video and Imaging	<a href="http://www.ti.com/video">www.ti.com/video</a>

### TI E2E Community

[e2e.ti.com](http://e2e.ti.com)