

- 1.6 to 2.7 Gigabits Per Second (Gbps) Serializer/Deserializer
- Hot-Plug Protection
- High-Performance 80-Pin BGA Microstar Junior™ Package (GQE)
- 2.5-V Power Supply for Low Power Operation
- Programmable Preemphasis Levels on Serial Output
- Interfaces to Backplane, Copper Cables, or Optical Converters
- On-Chip 8-bit/10-bit Encoding/Decoding, Comma Detect
- On-Chip PLL Provides Clock Synthesis From Low-Speed Reference
- Receiver Differential Input Thresholds 200 mV Minimum
- Low Power: < 500 mW
- 3 V Tolerance on Parallel Data Input Signals
- 16-Bit Parallel TTL Compatible Data Interface
- Ideal for High-Speed Backplane Interconnect and Point-to-Point Data Link
- Industrial Temperature Range (–40°C to 85°C RCP Package Only)
- Loss of Signal (LOS) Detection
- Integrated 50-Ω Termination Resistors on RX

## description

The TLK2711 is a member of the *WizardLink* transceiver family of multigigabit transceivers, intended for use in ultrahigh-speed bidirectional point-to-point data transmission systems. The TLK2711 supports an effective serial interface speed of 1.6 Gbps to 2.7 Gbps, providing up to 2.16 Gbps of data bandwidth.

The primary application of this chip is to provide very high-speed I/O data channels for point-to-point baseband data transmission over controlled impedance media of approximately 50 Ω. The transmission media can be printed-circuit board, copper cables, or fiber-optic cable. The maximum rate and distance of data transfer is dependent upon the attenuation characteristics of the media and the noise coupling to the environment.

This device can also be used to replace parallel data transmission architectures by providing a reduction in the number of traces, connector terminals, and transmit/receive terminals. Parallel data loaded into the transmitter is delivered to the receiver over a serial channel, which can be a coaxial copper cable, a controlled impedance backplane, or an optical link. It is then reconstructed into its original parallel format. It offers significant power and cost savings over parallel solutions, as well as scalability for higher data rates in the future.

The TLK2711 performs data conversion parallel-to-serial and serial-to-parallel. The clock extraction functions as a physical layer interface device. The serial transceiver interface operates at a maximum speed of 2.7 Gbps. The transmitter latches 16-bit parallel data at a rate based on the supplied reference clock (TXCLK). The 16-bit parallel data is internally encoded into 20 bits using an 8-bit/10-bit (8b/10b) encoding format. The resulting 20-bit word is then transmitted differentially at 20 times the reference clock (TXCLK) rate. The receiver section performs the serial-to-parallel conversion on the input data, synchronizing the resulting 20-bit wide parallel data to the recovered clock (RXCLK). It then decodes the 20-bit wide data using the 8-bit/10-bit decoding format resulting in 16 bits of parallel data at the receive data terminals (RXD0-15). The outcome is an effective data payload of 2 Gbps to 2.5 Gbps (16 bits data x the frequency).

The TLK2711 is provided in two packages options: a 80-pin ball grid array MicroStar Junior package and a 64-pin VQFP (RCP) package.

The TLK2711 provides an internal loopback capability for self-test purposes. Serial data from the serializer is passed directly to the deserializer, providing the protocol device with a functional self-check of the physical interface.



Please be aware that an important notice concerning availability, standard warranty, and use in critical applications of Texas Instruments semiconductor products and disclaimers thereto appears at the end of this data sheet.

MicroStar Junior and PowerPAD are trademarks of Texas Instruments.

PRODUCTION DATA information is current as of publication date. Products conform to specifications per the terms of Texas Instruments standard warranty. Production processing does not necessarily include testing of all parameters.



POST OFFICE BOX 655303 • DALLAS, TEXAS 75265

Copyright © 2001, Texas Instruments Incorporated

# TLK2711

## 1.6 TO 2.7 GBPS TRANSCEIVER

SLLS501 – SEPTEMBER 2001

---

### description (continued)

The TLK2711 has a loss of signal (LOS) detection circuit for conditions where the incoming signal no longer has a sufficient voltage amplitude to keep the clock recovery circuit in lock.

The TLK2711 allows users to implement redundant ports by connecting receive data bus terminals from two TLK2711 devices together. Asserting the LCKREFN to a low state will cause the receive data bus terminals, RXD[0:15], RXCLK, RKLSB, and RKMSB to go to a high-impedance state. This places the device in a transmit-only mode since the receiver is not tracking the data.

The TLK2711 uses a 2.5-V supply. The I/O section is 3 V compatible. With the 2.5-V supply the chipset is very power efficient, consuming less than 450 mW typically. The TLK2711 is characterized for operation from  $-40^{\circ}\text{C}$  to  $85^{\circ}\text{C}$  (RCP only).

The TLK2711 is designed to be hot-plug capable. An on-chip power-on reset circuit holds the RXCLK low and goes to high impedance on the parallel side output signal terminals as well as TXP and TXN during power up.



POST OFFICE BOX 655303 • DALLAS, TEXAS 75265

# TLK2711 1.6 TO 2.7 GBPS TRANSCEIVER

SLLS501 – SEPTEMBER 2001

**GQE PACKAGE  
(TOP VIEW)**

	9	8	7	6	5	4	3	2	1	
	GND	TXD1	TXP	TXN	PRE	RXP	RXN	RXD1	GND	J
	TXD3	TXD2	TXD0	GNDA	VDDA	GNDA	RXD0	RXD2	RXD3	H
	TXD5	TXD4	VDD	VDD	VDD	GND	GND	RXD4	RXD5	G
	TXD6	TXD7	VDD	VDD	VDD	GND	GND	RXD6	RXD7	F
	TXCLK	VDD	VDD	VDD	VDD	GND	GND	RXCLK	RXD8	E
	TXD8	TXD9	VDD	VDD	VDD	GND	GND	RXD11	RXD9	D
	TXD10	TXD11	VDD	VDD	VDD	GND		RXD12	RXD10	C
	TXD12	TXD13	TKMSB	LOOPEN	LCKREFN	TESTEN	RKMSB	RXD14	RXD13	B
	GND	TXD14	TXD15	TKLSB	ENABLE	PRBSEN	RKLSB	RXD15	GND	A
	9	8	7	6	5	4	3	2	1	

**RCP PACKAGE  
(TOP VIEW)**

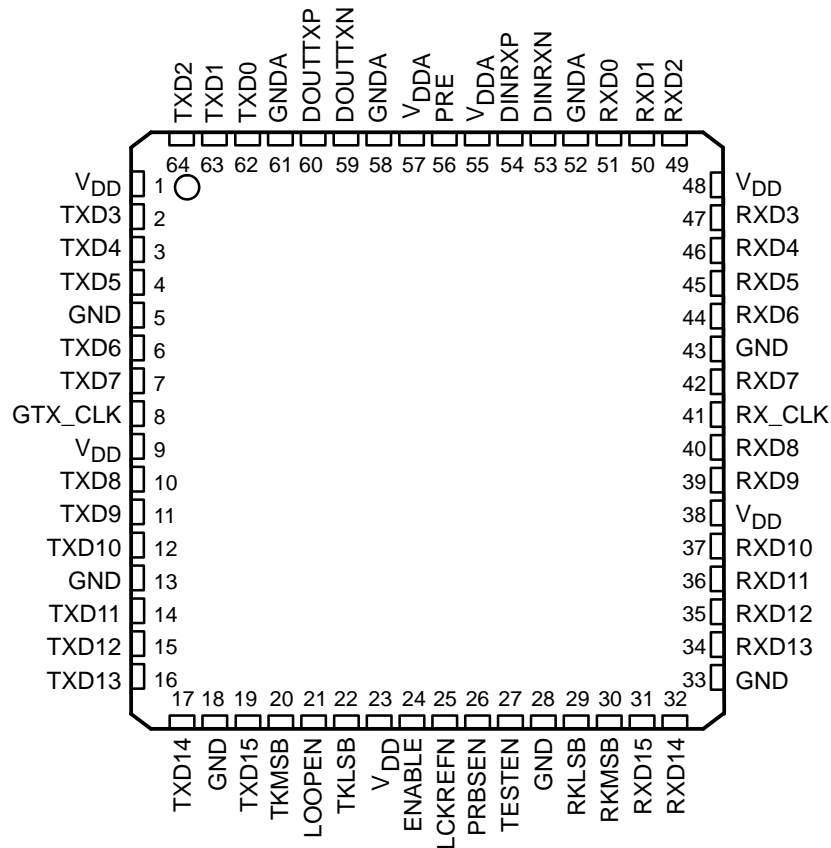

# TLK2711 1.6 TO 2.7 GBPS TRANSCEIVER

SLLS501 – SEPTEMBER 2001

## block diagram

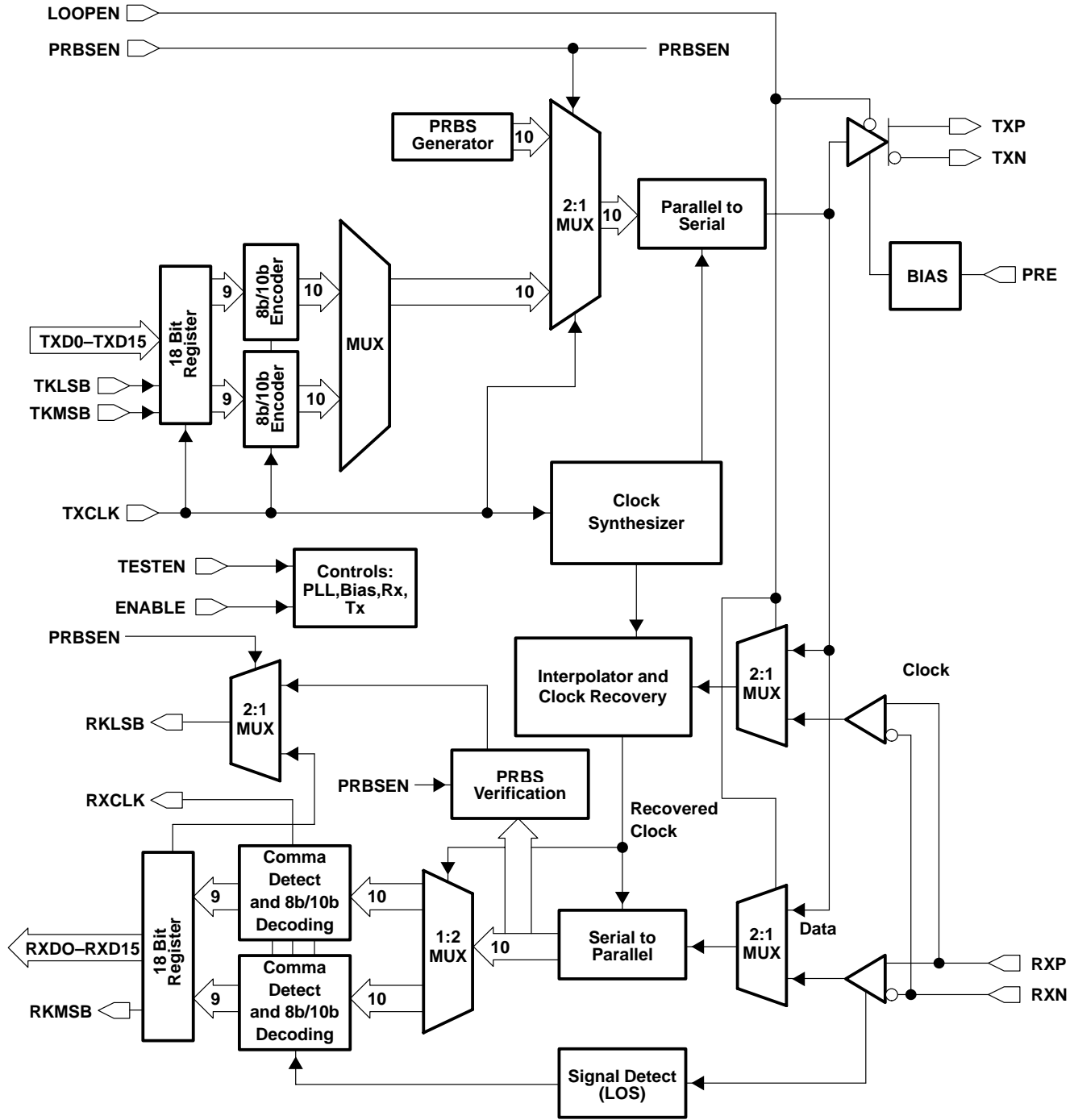

Figure 1. TLK2711 Block Diagram

### Terminal Functions

TERMINAL			I/O	DESCRIPTION
NAME	NO.			
	GQE	RCP		
ENABLE	A5	24	I <sup>†</sup>	Device enable. When this terminal is held low, the device is placed in power-down mode. Only the signal detect circuit on the serial receive pair is active. When asserted high while the device is in power-down mode, the transceiver goes into power-on reset before beginning normal operation.
GND	A1, J1, D3, E3, F3, G3, C4, D4, E4, F4, G4, A9, J9	5, 13, 18, 28, 33, 43		Digital logic ground. Provides a ground for the logic circuits and digital I/O buffers.
GNDA	H4, H6	52, 58, 61		Analog ground. GNDA provides a ground reference for the high-speed analog circuits, RX and TX.
LCKREFN	B5	25	I <sup>†</sup>	Lock to reference. When LCKREFN is low, the receiver clock is frequency locked to TXCLK. This places the device in a transmit only mode since the receiver is not tracking the data. When LCKREFN is asserted low, the receive data bus terminals, RXD[0:15], RXCLK and RKLSB, RKMSB are in a high-impedance state. When LCKREFN is deasserted high, the receiver is locked to the received data stream.
LOOPEN	B6	21	I <sup>‡</sup>	Loop enable. When LOOPEN is active high, the internal loop-back path is activated. The transmitted serial data is directly routed internally to the inputs of the receiver. This provides a self-test capability in conjunction with the protocol device. The TXP and TXN outputs are held in a high-impedance state during the loop-back test. LOOPEN is held low during standard operational state with external serial outputs and inputs active.
PRE	J5	56	I <sup>‡</sup>	Preemphasis control. Selects the amount of preemphasis to be added to the high speed serial output drivers. Left low or unconnected, 5% preemphasis is added. Pulled high, 20% preemphasis is added.
PRBSEN	A4	26	I <sup>‡</sup>	PRBS test enable. When asserted high results of pseudo random bit stream (PRBS) tests can be monitored on the RKLSB terminal. A high on RKLSB indicates that valid PRBS is being received.
RKLSB	A3	29	O	K-Code indicator/PRBS test results. When RKLSB is asserted high, an 8-bit/10-bit K code was received and is indicated by data bits RXD0–RXD7. When RKLSB is asserted low an 8-bit/10-bit D code is received and is presented on data bits RXD0–RXD7. When PRBSEN is asserted high this pin is used to indicate status of the PRBS test results (high = pass).
RKMSB	B3	30	O	K-code indicator. When RKMSB is asserted high an 8-bit/10-bit K code was received and is indicated by data bits RXD8 –RXD15. When RKMSB is asserted low an 8-bit/10-bit D code was received and is presented on data bits RXD8 – RXD15. If the differential signal on RXN and RXP drops below 200 mV, then RXD [0:15], RKLSB, and RKMSB are all asserted high.
RXCLK RX_CLK	E2	41	O	Recovered clock. Output clock that is synchronized to RXD [0..9], RKLSB, and RKMSB. RXCLK is the recovered serial data rate clock divided by 20. RXCLK is held low during power-on reset.

† Internal 10k pullup

‡ Internal 10k pulldown

# TLK2711

## 1.6 TO 2.7 GBPS TRANSCEIVER

SLLS501 – SEPTEMBER 2001

### Terminal Functions (Continued)

TERMINAL			I/O	DESCRIPTION
NAME	NO.			
	GQE	RCP		
RXD0 RXD1 RXD2 RXD3 RXD4 RXD5 RXD6 RXD7 RXD8 RXD9 RXD10 RXD11 RXD12 RXD13 RXD14 RXD15	H3 J2 H2 H1 G2 G1 F2 F1 E1 D1 C1 D2 C2 B1 B2 A2	51 50 49 47 46 45 44 42 40 39 37 36 35 34 32 31	O	Receive data bus. These outputs carry 16-bit parallel data output from the transceiver to the protocol device, synchronized to RXCLK. The data is valid on the rising edge of RXCLK as shown in Figure 5. These terminals are in high-impedance state during power-on reset.
RXN RXP DINRXN DINRXP	J3 J4	53 54	I	Serial receive inputs. RXP and RXN together are the differential serial input interface from a copper or an optical I/F module.
TESTEN	B4	27	I $\ddagger$	Test mode enable. This terminal should be left unconnected or tied low.
TKLSB	A6	22	I $\dagger$	K-code generator (LSB). When TKLSB is high, an 8-bit/10-bit K code is transmitted as controlled by data bits TXD0 – TXD7. When TKLSB is low an 8-bit/10-bit D code is transmitted as controlled by data bits TXD0 – TXD7.
TKMSB	B7	20	I $\dagger$	K-code generator (MSB). When TKMSB is high an 8-bit/10-bit K code is transmitted as controlled by data bits TXD8 – TXD15. When TKMSB is low an 8-bit/10-bit D code is transmitted as controlled by data bits TXD8 – TXD15.
TXCLK GTX_CLK	E9	8	I	Reference clock. TXCLK is a continuous external input clock that synchronizes the transmitter interface signals TKMSB, TKLSB and TXD [0..15]. The frequency range of TXCLK is 80 MHz to 135 MHz. The transmitter uses the rising edge of this clock to register the 16-bit input data TXD [0..15] for serialization.
TXD0 TXD1 TXD2 TXD3 TXD4 TXD5 TXD6 TXD7 TXD8 TXD9 TXD10 TXD11 TXD12 TXD13 TXD14 TXD15	H7 J8 H8 H9 G8 G9 F9 F8 D9 D8 C9 C8 B9 B8 A8 A7	62 63 64 2 3 4 6 7 10 11 12 14 15 16 17 19	I	Transmit data bus. These inputs carry the 16-bit parallel data output from a protocol device to the transceiver for encoding, serialization, and transmission. This 16-bit parallel data is clocked into the transceiver on the rising edge of TXCLK as shown in Figure 2.
TXN TXP DOUPTXN DOUPTXP	J6 J7	59 60	O	Serial transmit outputs. TXP and TXN are differential serial outputs that interface to copper or an optical I/F module. These terminals transmit NRZ data at a rate of 20 times the TXCLK value. TXP and TXN are put in a high-impedance state when LOOPEN is high and are active when LOOPEN is low. During power-on reset these terminals are high impedance.

$\dagger$  Internal 10k pullup

$\ddagger$  Internal 10k pulldown



POST OFFICE BOX 655303 • DALLAS, TEXAS 75265

Terminal Functions (Continued)

TERMINAL			I/O	DESCRIPTION
NAME	NO.			
	GQE	RCP	I/O	
VDD	C5, D5, E5, F5, G5, C6, D6, E6, F6, G6, C7, D7, E7, F7, G7, E8	1, 9, 23, 38, 48		Digital logic power. Provides power for all digital circuitry and digital I/O buffers.
VDDA	H5	55, 57		Analog power. VDDA provides a supply reference for the high-speed analog circuits, receiver and transmitter

detailed description

transmit interface

The transmitter portion registers valid incoming 16-bit wide data (TXD[0:15]) on the rising edge of the TXCLK. The data is then 8-bit/10-bit encoded, serialized, and transmitted sequentially over the differential high-speed I/O channel. The clock multiplier multiplies the reference clock (TXCLK) by a factor of 10 times, creating a bit clock. This internal bit clock is fed to the parallel-to-serial shift register which transmits data on both the rising and falling edges of the bit clock, providing a serial data rate that is 20 times the reference clock. Data is transmitted LSB (TXD0) first.

transmit data bus

The transmit bus interface accepts 16-bit single-ended TTL parallel data at the TXD[0:15] terminals. Data and K-code control is valid on the rising edge of the TXCLK. The TXCLK is used as the word clock. The data, K-code, and clock signals must be properly aligned as shown in Figure 2. Detailed timing information can be found in the electrical characteristics table.

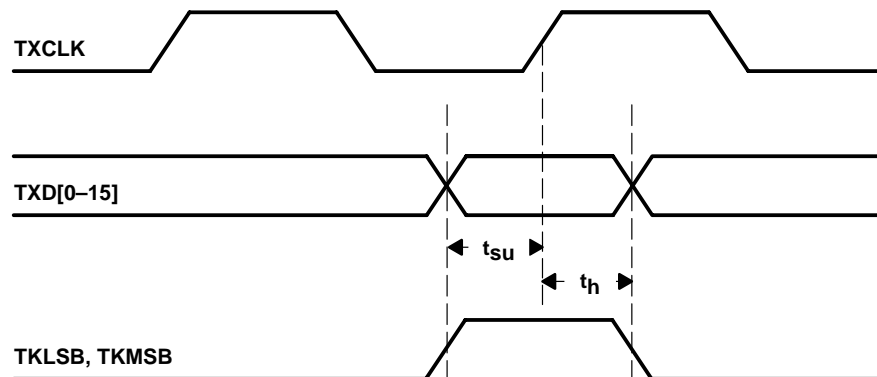

Figure 2. Transmit Timing Waveform

transmission latency

The data transmission latency of the TLK2711 is defined as the delay from the initial 16-bit word load to the serial transmission of bit 0. The transmit latency is fixed once the link is established. However, due to silicon process variations and implementation variables such as supply voltage and temperature, the exact delay varies slightly. The minimum transmit latency  $t_d(\text{Tx latency})$  is 34 bit times; the maximum is 38 bit times. Figure 3 illustrates the timing relationship between the transmit data bus, the TXCLK, and the serial transmit terminals.

# TLK2711

## 1.6 TO 2.7 GBPS TRANSCEIVER

SLLS501 – SEPTEMBER 2001

### detailed description (continued)

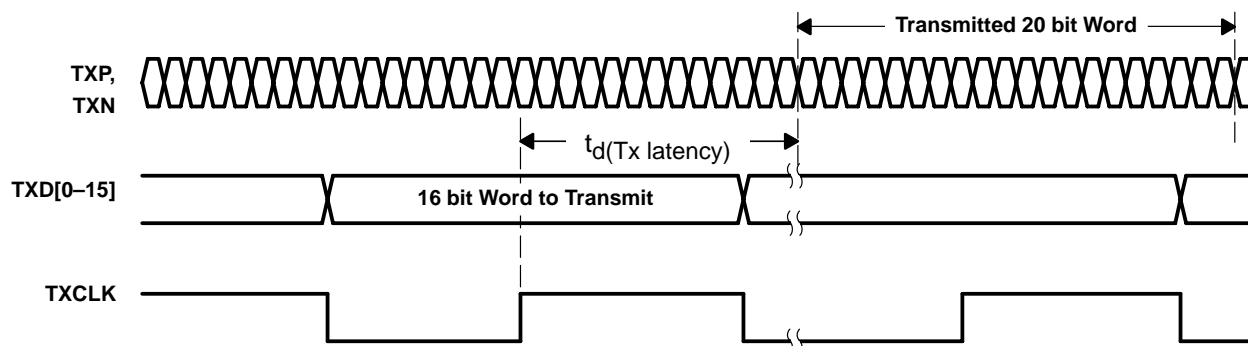

Figure 3. Transmitter Latency

### 8-bit/10-bit encoder

All true serial interfaces require a method of encoding to insure minimum transition density so that the receiving PLL has a minimal number of transitions to stay locked on. The encoding scheme maintains the signal dc balance by keeping the number of ones and zeros the same. This provides good transition density for clock recovery and improves error checking. The TLK2711 uses the 8-bit/10-bit encoding algorithm that is used by fibre channel and gigabit ethernet. This is transparent to the user, as the TLK2711 internally encodes and decodes the data such that the user reads and writes actual 16-bit data.

The 8-bit/10-bit encoder converts 8-bit wide data to a 10-bit wide encoded data character to improve its transmission characteristics. Since the TLK2711 is a 16-bit wide interface, the data is split into two 8-bit wide bytes for encoding. Each byte is fed into a separate encoder. The encoding is dependent upon two additional input signals, the TKMSB and TKLSB.

Table 1. Transmit Data Controls

TKLSB	TKMSB	16 BIT PARALLEL INPUT
0	0	Valid data on TXD(0-7), Valid data TXD(8-15)
0	1	Valid data on TXD(0-7), K code on TXD(8-15)
1	0	K code on TXD(0-7), Valid data on TXD(8-15)
1	1	K code on TXD(0-7), K code on TXD(8-15)

### PRBS generator

The TLK2711 has a built-in  $2^7-1$  PRBS (pseudorandom bit stream) function. When the PRBSEN terminal is forced high, the PRBS test is enabled. A PRBS is generated and fed into the 10-bit parallel-to-serial converter input register. Data from the normal input source is ignored during the PRBS mode. The PRBS pattern is then fed through the transmit circuitry as if it were normal data and sent out to the transmitter. The output can be sent to a BERT (bit error rate tester), the receiver of another TLK2711, or looped back to the receive input. Since the PRBS is not really random but a predetermined sequence of ones and zeroes, the data can be captured and checked for errors by a BERT.

### parallel-to-serial

The parallel-to-serial shift register takes in the 20-bit wide data word multiplexed from the two parallel 8-bit/10-bit encoders and converts it to a serial stream. The shift register is clocked on both the rising and falling edge of the internally generated bit clock, which is 10 times the TXCLK input frequency. The LSB (TXD0) is transmitted first.



**detailed description (continued)**

**high-speed data output**

The high-speed data output driver consists of a voltage mode logic (VML) differential pair optimized for a 50-Ω impedance environment. The magnitude of the differential pair signal swing is compatible with pseudo emitter coupled logic (PECL) levels when ac-coupled. The line can be directly-coupled or ac-coupled. Refer to Figure 11 and Figure 12 for termination details. The outputs also provide preemphasis to compensate for ac loss when driving a cable or PCB backplane trace over a long distance (see Figure 4). The level of preemphasis is controlled by PRE as shown in Table 2 .

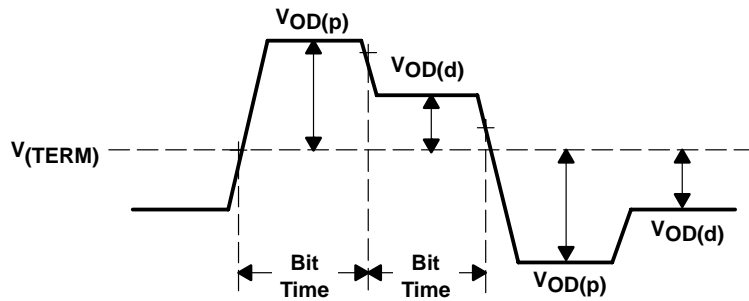

**Figure 4. Output Voltage Under Preemphasis (|VTXP–VTXN|)**

**Table 2. Programmable Preemphasis**

PRE	PREEMPHASIS LEVEL(%) VOD(P), VOD(D) <sup>†</sup>
0	5%
1	20%

<sup>†</sup> VOD(p) : Voltage swing when there is a transition in the data stream  
VOD(d): Voltage swing when there is no transition in the data stream.

**receive interface**

The receiver portion of the TLK2711 accepts 8-bit/10-bit encoded differential serial data. The interpolator and clock recovery circuit locks to the data stream and extract the bit rate clock. This recovered clock is used to retime the input data stream. The serial data is then aligned to two separate 10-bit word boundaries, 8-bit/10-bit decoded and output on a 16-bit wide parallel bus synchronized to the extracted receive clock. The data is received LSB (RXD0) first.

**receive data bus**

The receive bus interface drives 16-bit wide single-ended TTL parallel data at the RXD[0:15] terminals. Data is valid on the rising edge of the RXCLK. The RXCLK is used as the recovered word clock. The data, RKLSB, RKMSB, and clock signals are aligned as shown in Figure 5. Detailed timing information can be found in the switching characteristics table.

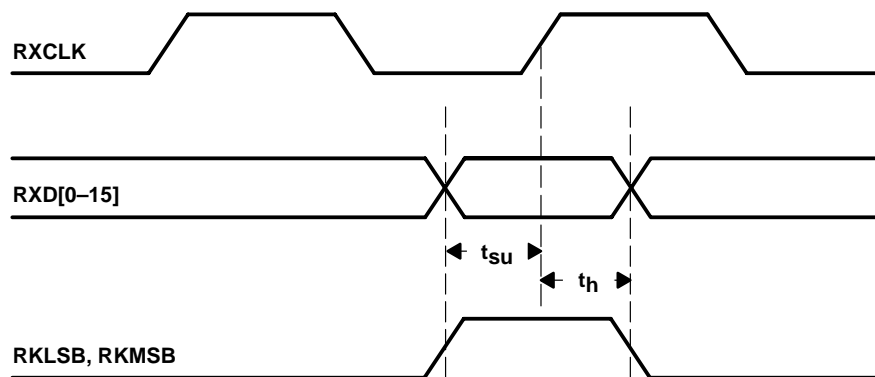

**Figure 5. Receive Timing Waveform**

# TLK2711

## 1.6 TO 2.7 GBPS TRANSCEIVER

SLLS501 – SEPTEMBER 2001

### detailed description (continued)

#### data reception latency

The serial-to-parallel data receive latency is the time from when the first bit arrives at the receiver until it is output in the aligned parallel word. The receive latency is fixed once the link is established. However, due to silicon process variations and implementation variables such as supply voltage and temperature, the exact delay varies slightly. The minimum receive latency  $t_d(\text{Rx latency})$  is 76 bit times; the maximum is 107 bit times. Figure 6 illustrates the timing relationship between the serial receive terminals, the recovered word clock (RXCLK), and the receive data bus.

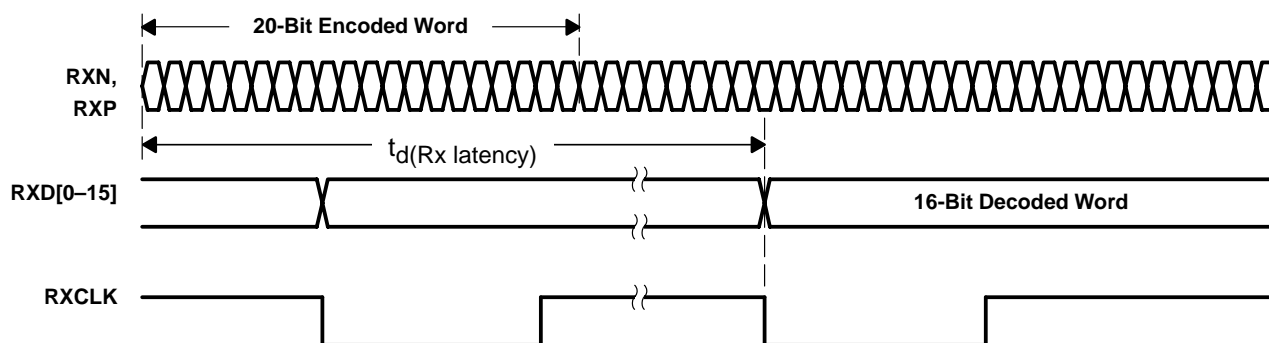

Figure 6. Receiver Latency

#### serial-to-parallel

Serial data is received on the RXP and RXN terminals. The interpolator and clock recovery circuit locks to the data stream if the clock to be recovered is within 200 PPM of the internally generated bit rate clock. The recovered clock is used to retime the input data stream. The serial data is then clocked into the serial-to-parallel shift registers. The 10-bit wide parallel data is then multiplexed and fed into two separate 8-bit/10-bit decoders where the data is then synchronized to the incoming data stream word boundary by detection of the comma 8-bit/10-bit synchronization pattern.

#### comma detect and 8-bit/10-bit decoding

The TLK2711 has two parallel 8-bit/10-bit decode circuits. Each 8-bit/10-bit decoder converts 10 bit encoded data (half of the 20-bit received word) back into 8 bits. The comma detect circuit is designed to provide for byte synchronization to an 8-bit/10-bit transmission code. When parallel data is clocked into a parallel to serial converter, the byte boundary that was associated with the parallel data is now lost in the serialization of the data. When the serial data is received and converted to parallel format again, a method is needed to recognize the byte boundary. Generally this is accomplished through the use of a synchronization pattern. This is generally a unique pattern of 1's and 0's that either cannot occur as part of valid data or is a pattern that repeats at defined intervals. The 8-bit/10-bit encoding contains a character called the comma (b0011111 or b1100000), which is used by the comma detect circuit on the TLK2711 to align the received serial data back to its original byte boundary. The decoder detects the comma, generating a synchronization signal aligning the data to their 10-bit boundaries for decoding; the comma is mapped into the LSB. The decoder then converts the data back into 8-bit data. The output from the two decoders is latched into the 16-bit register synchronized to the recovered parallel data clock (RXCLK) and output valid on the rising edge of the RXCLK.

#### NOTE:

The TLK2711 only achieves byte alignment on the 0011111 comma.

**comma detect and 8-bit/10-bit decoding (continued)**

Decoding provides two additional status signals, RKLSB and RKMSB. When RKLSB is asserted, an 8-bit/10-bit K code was received and the specific K code is presented on the data bits RXD0–RXD7; otherwise, an 8-bit/10-bit D code was received. When RKMSB is asserted, an 8-bit/10-bit K code was received and the specific K-code is presented on data bits RXD8–RXD15; otherwise, an 8-bit/10-bit D code was received (see Table 3). The valid K codes the TLK2711 decodes are provided in Table 4. An error detected on either byte, including K codes not in Table 4, causes that byte only to indicate a K0.0 code on the RK×SB and associated data pins, where K0.0 is known to be an invalid 8-bit/10-bit code. A loss of input signal causes a K31.7 code to be presented on both bytes, where K31.7 is also known to be an invalid 8-bit/10-bit code.

**Table 3. Receive Status Signals**

RKLSB	RKMSB	DECODED 20 BIT OUTPUT
0	0	Valid data on RXD(0–7), Valid data RXD(8–15)
0	1	Valid data on RXD(0–7), K code on RXD(8–15)
1	0	K code on RXD(0–7), Valid data on RXD(8–15)
1	1	K code on RXD(0–7), K code on RXD(8–15)

**Table 4. Valid K Characters**

K CHARACTER	RECEIVE DATA BUS (RXD[7–0]) OR (RXD[15–8])
K28.0	000 11100
K28.1†	001 11100
K28.2	010 11100
K28.3	011 11100
K28.4	100 11100
K28.5†	101 11100
K28.6	110 11100
K28.7†	111 11100
K23.7	111 10111
K27.7	111 11011
K29.7	111 11101
K30.7	111 11110

† Should only be present on RXD[7–0] when in running disparity < 0.

**power down mode**

When the ENABLE pin is pulled low, the TLK2711 goes into power-down mode. In the power-down mode, the serial transmit pins (TXN), the receive data bus pins (RXD[0:15]), and RKLSB goes into a high-impedance state. In the power-down condition, the signal detection circuit draws less than 15 mW. When the TLK2711 is in the power-down mode, the clock signal on the TXCLK terminal must be provided.

**loss of signal detection**

The TLK2711 has a loss of signal detection circuit for conditions where the incoming signal no longer has a sufficient voltage level to keep the clock recovery circuit in lock. The signal detection circuit is intended to be an indication of gross signal error conditions, such as a detached cable or no signal being transmitted, and not an indication of signal coding health. The TLK2711 reports this condition by asserting RKLSB, RKMSB and RXD[0:15] terminals to a high state. As long as the differential signal is above 200 mV in differential magnitude, the LOS circuit does not signal an error condition.

**PRBS verification**

The TLK2711 also has a built-in BERT function in the receiver side that is enabled by the PRBSEN. It can check for errors and report the errors by forcing the RKLSB terminal low.



# TLK2711

## 1.6 TO 2.7 GBPS TRANSCEIVER

SLLS501 – SEPTEMBER 2001

---

### **detailed description (continued)**

#### **reference clock input**

The reference clock (TXCLK) is an external input clock that synchronizes the transmitter interface. The reference clock is then multiplied in frequency 10 times to produce the internal serialization bit clock. The internal serialization bit clock is frequency-locked to the reference clock and used to clock out the serial transmit data on both its rising and falling edges, providing a serial data rate that is 20 times the reference clock.

#### **operating frequency range**

The TLK2711 can operate at a serial data rate from 1.6 Gbps to 2.7 Gbps. To achieve these serial rates, TXCLK must be within 80 MHz to 135 MHz. The TXCLK must be within  $\pm 100$  PPM of the desired parallel data rate clock.

#### **testability**

The TLK2711 has a comprehensive suite of built-in self-tests. The loopback function provides for at-speed testing of the transmit/receive portions of the circuitry. The enable terminal allows for all circuitry to be disabled so that a quiescent current test can be performed. The PRBS function allows for BIST (built-in self-test).

#### **loopback testing**

The transceiver can provide a self-test function by enabling (LOOPEN) the internal loop-back path. Enabling this terminal causes serial-transmitted data to be routed internally to the receiver. The parallel data output can be compared to the parallel input data for functional verification. (The external differential output is held in a high-impedance state during the loopback testing.)

#### **built-in self-test (BIST)**

The TLK2711 has a BIST function. By combining PRBS with loopback, an effective self-test of all the circuitry running at full speed can be realized. The successful completion of the BIST is reported on the RKLSB terminal.

#### **power-on reset**

Upon application of minimum valid power, the TLK2711 generates a power-on reset. During the power-on reset the RXD[0..15], RKLSB, and RKMSB signal terminals go to a high-impedance state. The RXCLK is held low. The length of the power-on reset cycle is dependent upon the TXCLK frequency, but is less than 1 ms.





# TLK2711

## 1.6 TO 2.7 GBPS TRANSCEIVER

SLLS501 – SEPTEMBER 2001

reference clock (TXCLK) timing requirements over recommended operating conditions (unless otherwise noted)

PARAMETER	TEST CONDITIONS	MIN	TYP	MAX	UNIT
Frequency	Minimum data rate	Typ-0.01%	80	Typ+0.01%	MHz
Frequency	Maximum data rate	Typ-0.01%	135	Typ+0.01%	MHz
Frequency tolerance		-100		100	ppm
Duty cycle		40%	50%	60%	
Jitter	Peak-to-peak			40	ps

TTL input electrical characteristics over recommended operating conditions (unless otherwise noted), TTL signals: TXDO–TXD15, TXCLK, LOOPEN, LCKREFN, ENABLE, PRBS\_EN, TKLSB, TKMSB, PRE

PARAMETER	TEST CONDITIONS	MIN	NOM	MAX	UNIT
V <sub>IH</sub> High-level input voltage	See Figure 7	1.7		3.6	V
V <sub>IL</sub> Low-level input voltage	See Figure 7			0.80	V
I <sub>IH</sub> Input high current	V <sub>DD</sub> = MAX, V <sub>IN</sub> = 2 V			40	μA
I <sub>IL</sub> Input low current	V <sub>DD</sub> = MAX, V <sub>IN</sub> = 0.4 V	-40			μA
C <sub>I</sub> Receiver input capacitance				4	pF
t <sub>r</sub> Rise time, TXCLK, TKMSB, TKLSB, TXD[0..15]	0.7 V to 1.9 V, C = 5 pF, See Figure 7		1		ns
t <sub>f</sub> Fall time, TXCLK, TKMSB, TKLSB, TXD[0..15]	1.9 V to 0.7 V, C = 5 pF, See Figure 7		1		ns
t <sub>su</sub> TXD[0..15], TKMSB, TKLSB setup to ↑ TXCLK	See Figure 7	1.5			ns
t <sub>h</sub> TXD, TKMSB, TKLSB hold to ↑ TXCLK	See Figure 7	0.4			ns

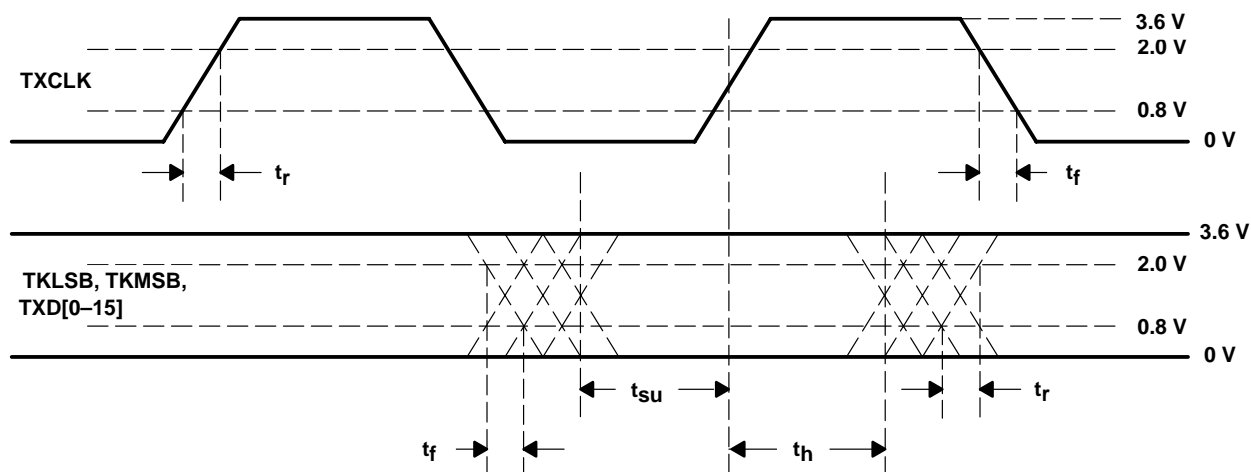

Figure 7. TTL Data Input Valid Levels for AC Measurements

**TTL output switching characteristics over recommended operating conditions (unless otherwise noted)**

PARAMETER		TEST CONDITIONS	MIN	NOM	MAX	UNIT
$V_{OH}$	High-level output voltage	$I_{OH} = -1 \text{ mA}$ , $V_{DD} = \text{MIN}$	2.10	2.3		V
$V_{OL}$	Low-level output voltage	$I_{OL} = 1 \text{ mA}$ , $V_{DD} = \text{MIN}$	GND	0.25	0.5	V
$t_{r(\text{slew})}$	Slew rate (rising), magnitude of RXCLK, RKLSB, RKMSB, RXD[0..15]	0.8 V to 2 V, C = 5 pF, See Figure 8	0.5			V/ns
$t_{f(\text{slew})}$	Slew rate (falling), magnitude of RXCLK, RKLSB, RKMSB, RXD[0..15]	0.8 V to 2 V, C = 5 pF, See Figure 8	0.5			V/ns
$t_{su}$	RXD[0..15], RKMSB, RKLSB setup to $\uparrow$ RXCLK	50% voltage swing, TXCLK = 80 MHz, Figure 8	3			ns
		50% voltage swing, TXCLK = 135 MHz, See Figure 8	2.5			ns
$t_h$	RXD[0..15], RKMSB, RKLSB hold to $\uparrow$ RXCLK	50% voltage swing, TXCLK = 80 MHz, See Figure 8	3			ns
		50% voltage swing, TXCLK = 135 MHz, See Figure 8	2.5			ns

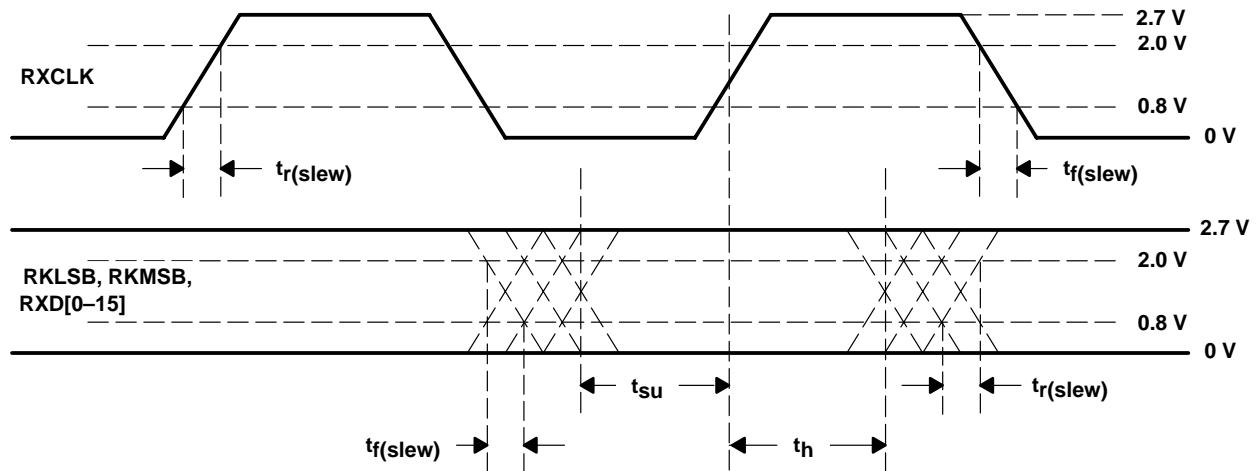

Figure 8. TTL Data Output Valid Levels for AC Measurements

# TLK2711

## 1.6 TO 2.7 GBPS TRANSCEIVER

SLLS501 – SEPTEMBER 2001

### transmitter/receiver characteristics

PARAMETER	TEST CONDITIONS	MIN	TYP	MAX	UNIT
$V_{OD(p)}$ Preemphasis $V_{OD}$ , direct, $V_{OD(p)} =  V_{TXP} - V_{TXN} $	$R_t = 50 \Omega$ , PREM = high, dc-coupled, See Figure 9	655	725	795	mV
	$R_t = 50 \Omega$ , PREM = low, dc-coupled, See Figure 9	590	650	710	
$V_{OD(pp\_p)}$ Differential, peak-to-peak output voltage with preemphasis	$R_t = 50 \Omega$ , PREM = high, dc-coupled, See Figure 9	1310	1450	1590	mV <sub>p-p</sub>
	$R_t = 50 \Omega$ , PREM = low, dc-coupled, See Figure 9	1180	1300	1420	
$V_{OD(d)}$ Deemphasis output voltage, $ V_{TXP} - V_{TXN} $	$R_t = 50 \Omega$ , DC-coupled, See Figure 9	540	600	660	mV
$V_{OD(pp\_d)}$ Differential, peak-to-peak output voltage with deemphasis	$R_t = 50 \Omega$ , dc-coupled, See Figure 9	1080	1200	1320	mV <sub>p-p</sub>
$V_{(cmt)}$ Transmit common mode voltage range, $(V_{TXP} + V_{TXN})/2$	$R_t = 50 \Omega$ , See Figure 9	1000	1250	1400	mV
$V_{ID}$ Receiver input voltage differential, $ V_{RXP} - V_{RXN} $		200		1600	mV
$V_{(cmr)}$ Receiver common mode voltage range, $(V_{RXP} + V_{RXN})/2$		1000	1250	2250	mV
$I_{lkg}$ Receiver input leakage current		-10		10	$\mu A$
$C_i$ Receiver input capacitance				2	pF
Serial data total jitter (peak-to-peak)	Differential output jitter at 2.7 Gbps, Random + deterministic, PRBS pattern		0.20		UI†
	Differential output jitter at 1.5 Gbps, Random + deterministic, PRBS pattern		0.16		UI†
$t_r, t_f$ Differential output signal rise, fall time (20% to 80%)	$R_L = 50 \Omega$ , $C_L = 5$ pF, See Figure 9		150		ps
Jitter tolerance	Differential input jitter, random + deterministic, PRBS pattern at zero crossing	0.60			UI
$t_d$ (Tx latency) Tx latency	See Figure 3	34		38	bits
$t_d$ (Rx latency) Rx latency	See Figure 6	76		107	bits

† UI is the time interval of one serialized bit.

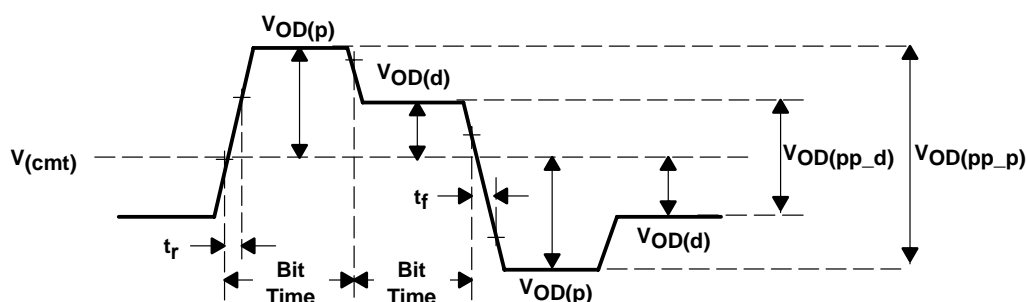

Figure 9. Differential and Common-Mode Output Voltage Definitions

**THERMAL INFORMATION**

**thermal characteristics**

PARAMETER		TEST CONDITION	MIN	TYP	MAX	UNIT
R <sub>θJA</sub>	Junction-to-free-air thermal resistance	Board-mounted, no air flow, high conductivity TI recommended test board, chip soldered or greased to thermal land		21.47		°C/W
		Board-mounted, no air flow, high conductivity TI recommended test board with thermal land but no solder or grease thermal connection to thermal land		42.20		
		Board-mounted, no air flow, JEDEC test board		75.88		
R <sub>θJC</sub>	Junction-to-case thermal resistance	Board-mounted, no air flow, high conductivity TI recommended test board, chip soldered or greased to thermal land		0.38		°C/W
		Board-mounted, no air flow, high conductivity TI recommended test board with thermal land but no solder or grease thermal connection to thermal land		0.38		
		Board-mounted, no air flow, JEDEC test board		7.8		

# TLK2711 1.6 TO 2.7 GBPS TRANSCEIVER

SLLS501 – SEPTEMBER 2001

## APPLICATION INFORMATION

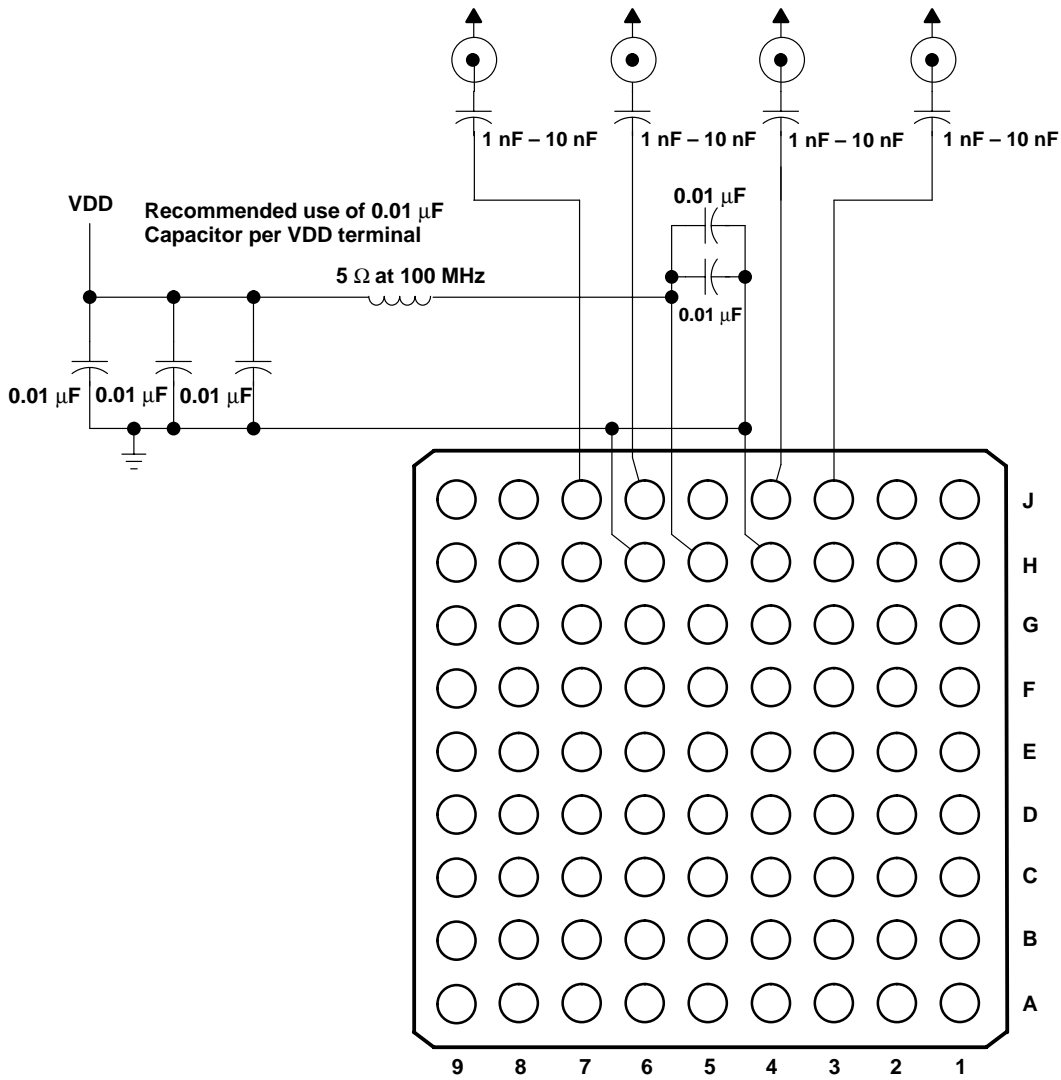

Figure 10. External Component Interconnection

APPLICATION INFORMATION

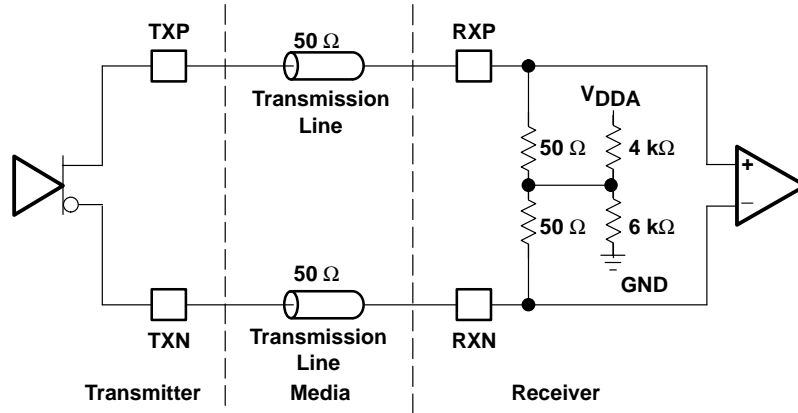

Figure 11. High-Speed I/O Directly-Coupled Mode

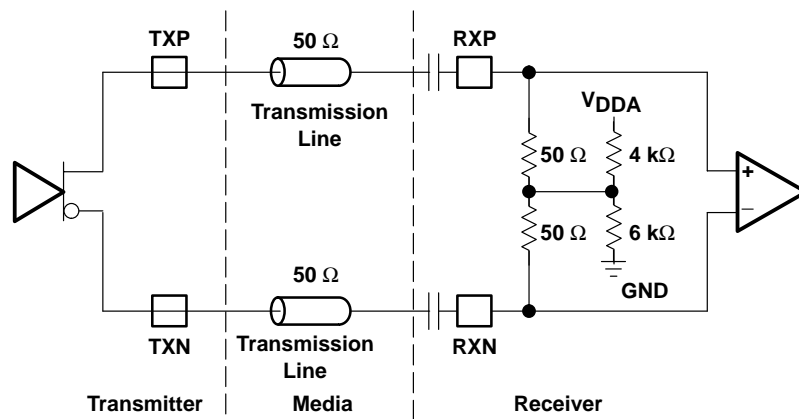

Figure 12. High-Speed I/O AC-Coupled Mode

**PACKAGING INFORMATION**

Orderable Device	Status (1)	Package Type	Package Drawing	Pins	Package Qty	Eco Plan (2)	Lead/Ball Finish (6)	MSL Peak Temp (3)	Op Temp (°C)	Device Marking (4/5)	Samples
TLK2711IRCP	NRND	HVQFP	RCP	64	160	Green (RoHS & no Sb/Br)	CU NIPDAU	Level-3-260C-168 HR	-40 to 85	TLK2711I	
TLK2711IRCPG4	NRND	HVQFP	RCP	64	160	Green (RoHS & no Sb/Br)	CU NIPDAU	Level-3-260C-168 HR	-40 to 85	TLK2711I	
TLK2711JRGQE	OBSOLETE	BGA MICROSTAR JUNIOR	GQE	80		TBD	Call TI	Call TI	0 to 70		
TLK2711JRZQE	LIFEBUY	BGA MICROSTAR JUNIOR	ZQE	80	360	Green (RoHS & no Sb/Br)	SNAGCU	Level-3-260C-168 HR	0 to 70	TLK2711JR	

(1) The marketing status values are defined as follows:

**ACTIVE:** Product device recommended for new designs.

**LIFEBUY:** TI has announced that the device will be discontinued, and a lifetime-buy period is in effect.

**NRND:** Not recommended for new designs. Device is in production to support existing customers, but TI does not recommend using this part in a new design.

**PREVIEW:** Device has been announced but is not in production. Samples may or may not be available.

**OBSOLETE:** TI has discontinued the production of the device.

(2) Eco Plan - The planned eco-friendly classification: Pb-Free (RoHS), Pb-Free (RoHS Exempt), or Green (RoHS & no Sb/Br) - please check <http://www.ti.com/productcontent> for the latest availability information and additional product content details.

**TBD:** The Pb-Free/Green conversion plan has not been defined.

**Pb-Free (RoHS):** TI's terms "Lead-Free" or "Pb-Free" mean semiconductor products that are compatible with the current RoHS requirements for all 6 substances, including the requirement that lead not exceed 0.1% by weight in homogeneous materials. Where designed to be soldered at high temperatures, TI Pb-Free products are suitable for use in specified lead-free processes.

**Pb-Free (RoHS Exempt):** This component has a RoHS exemption for either 1) lead-based flip-chip solder bumps used between the die and package, or 2) lead-based die adhesive used between the die and leadframe. The component is otherwise considered Pb-Free (RoHS compatible) as defined above.

**Green (RoHS & no Sb/Br):** TI defines "Green" to mean Pb-Free (RoHS compatible), and free of Bromine (Br) and Antimony (Sb) based flame retardants (Br or Sb do not exceed 0.1% by weight in homogeneous material)

(3) MSL, Peak Temp. - The Moisture Sensitivity Level rating according to the JEDEC industry standard classifications, and peak solder temperature.

(4) There may be additional marking, which relates to the logo, the lot trace code information, or the environmental category on the device.

(5) Multiple Device Markings will be inside parentheses. Only one Device Marking contained in parentheses and separated by a "~" will appear on a device. If a line is indented then it is a continuation of the previous line and the two combined represent the entire Device Marking for that device.

<sup>(6)</sup> Lead/Ball Finish - Orderable Devices may have multiple material finish options. Finish options are separated by a vertical ruled line. Lead/Ball Finish values may wrap to two lines if the finish value exceeds the maximum column width.

**Important Information and Disclaimer:**The information provided on this page represents TI's knowledge and belief as of the date that it is provided. TI bases its knowledge and belief on information provided by third parties, and makes no representation or warranty as to the accuracy of such information. Efforts are underway to better integrate information from third parties. TI has taken and continues to take reasonable steps to provide representative and accurate information but may not have conducted destructive testing or chemical analysis on incoming materials and chemicals. TI and TI suppliers consider certain information to be proprietary, and thus CAS numbers and other limited information may not be available for release.

In no event shall TI's liability arising out of such information exceed the total purchase price of the TI part(s) at issue in this document sold by TI to Customer on an annual basis.

**OTHER QUALIFIED VERSIONS OF TLK2711 :**

- Space: [TLK2711-SP](#)

NOTE: Qualified Version Definitions:

- Space - Radiation tolerant, ceramic packaging and qualified for use in Space-based application

# MECHANICAL DATA

ZQE (S-PBGA-N80)

PLASTIC BALL GRID ARRAY

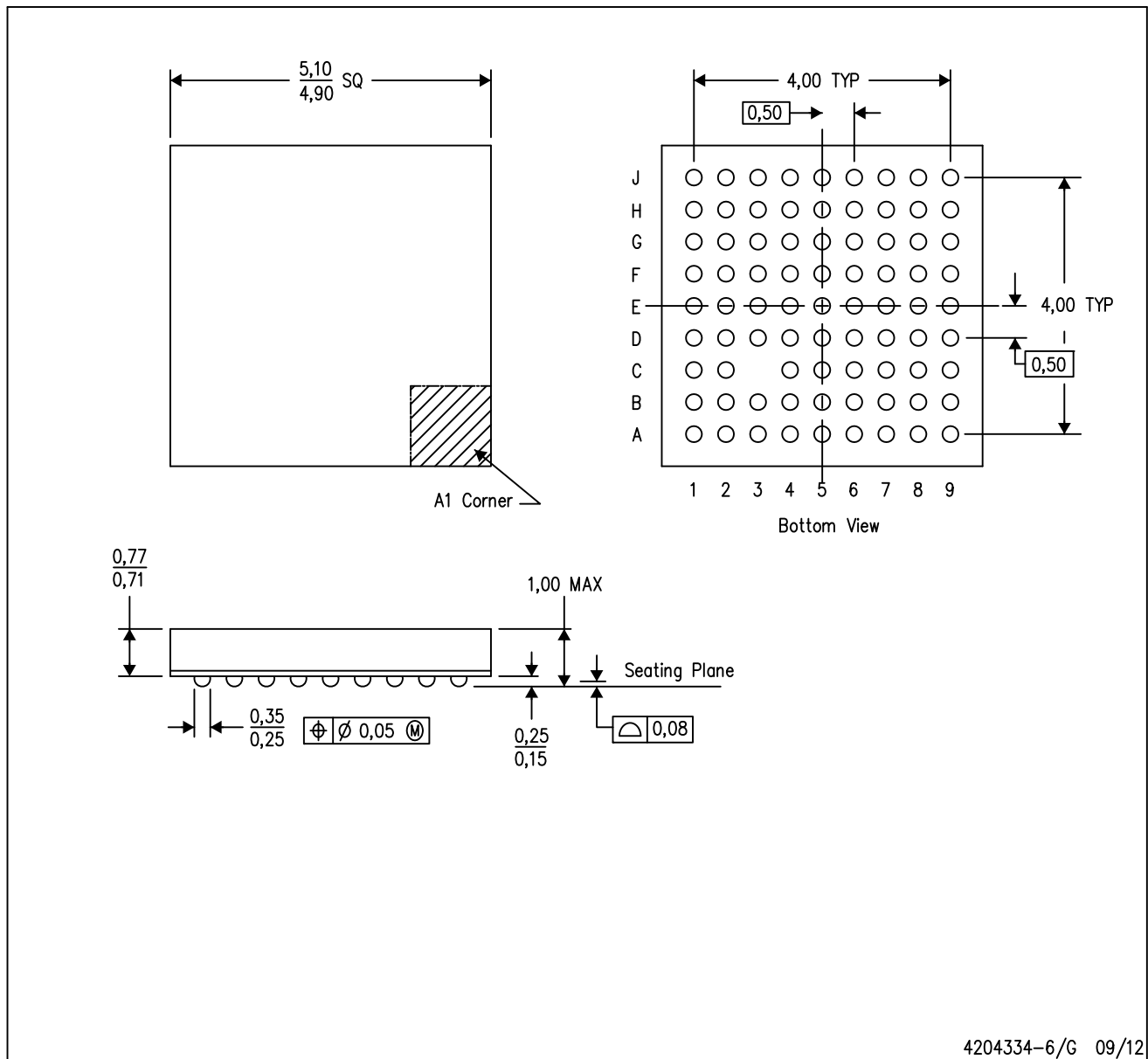

- NOTES:
- A. All linear dimensions are in millimeters. Dimensioning and tolerancing per ASME Y14.5M-1994.
  - B. This drawing is subject to change without notice.
  - C. Falls within JEDEC MO-225
  - D. This is a Pb-free solder ball design.

MicroStar Junior is a trademark of Texas Instruments.

GQE (S-PBGA-N80)

PLASTIC BALL GRID ARRAY

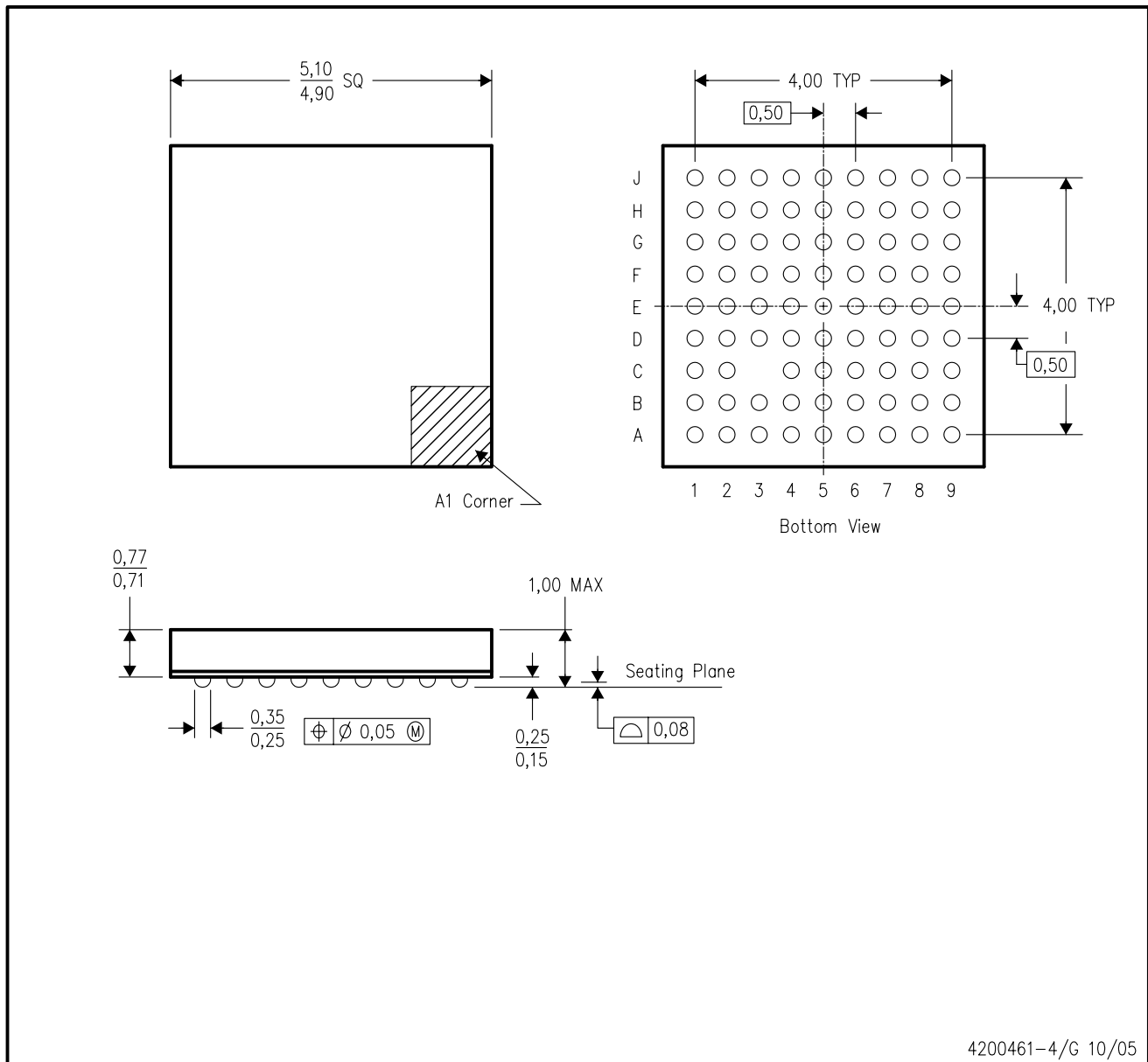

- NOTES:
- A. All linear dimensions are in millimeters.
  - B. This drawing is subject to change without notice.
  - C. Falls within JEDEC MO-225

RCP (S-PQFP-G64)

PowerPAD™ PLASTIC QUAD FLATPACK

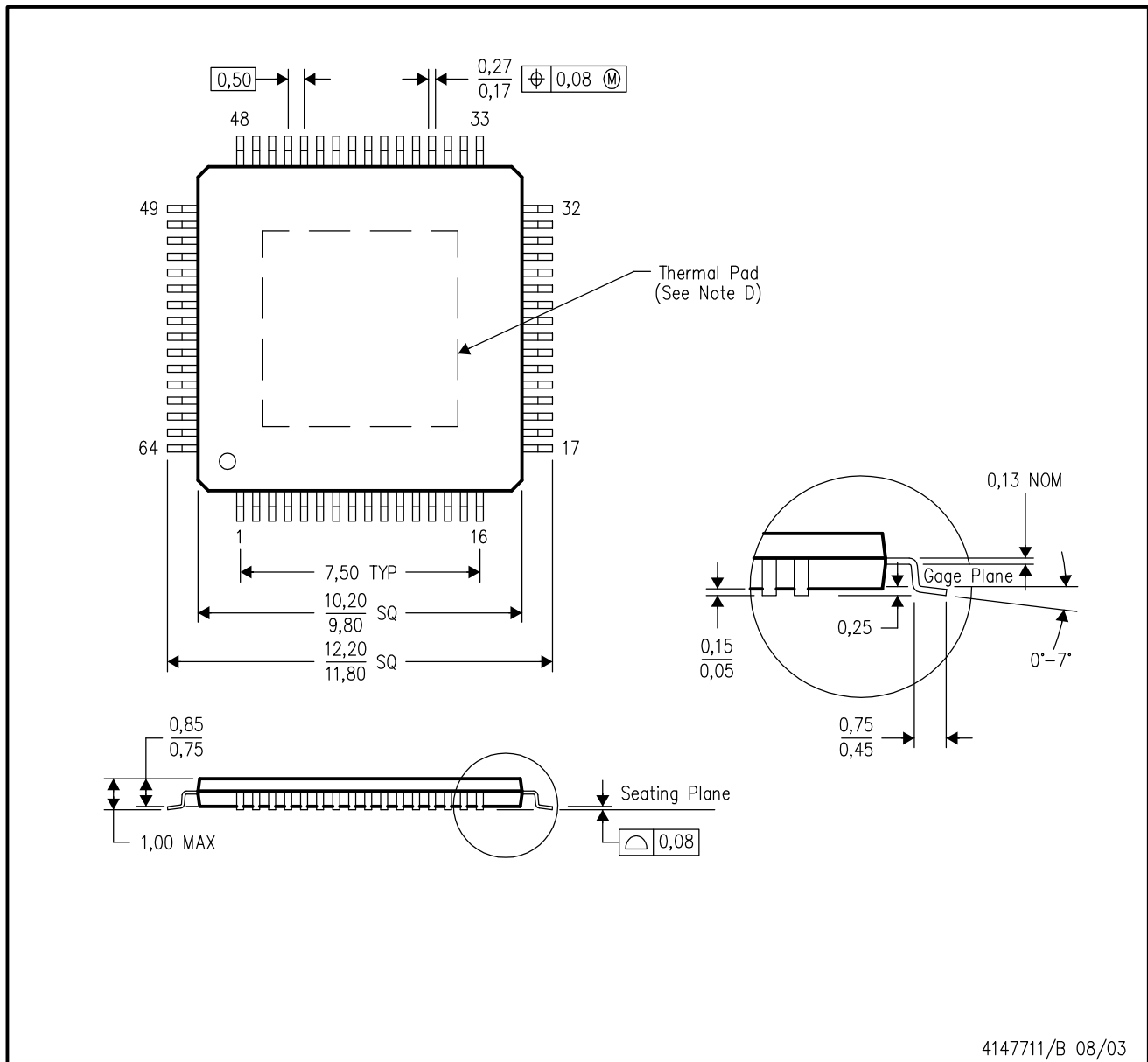

- NOTES:
- A. All linear dimensions are in millimeters.
  - B. This drawing is subject to change without notice.
  - C. Body dimensions do not include mold flash or protrusion
  - D. This package is designed to be soldered to a thermal pad on the board. Refer to Technical Brief, PowerPad Thermally Enhanced Package, Texas Instruments Literature No. SLMA002 for information regarding recommended board layout. This document is available at [www.ti.com](http://www.ti.com) <<http://www.ti.com>>.
  - E. Falls within JEDEC MS-026

PowerPAD is a trademark of Texas Instruments.

THERMAL INFORMATION

This PowerPAD™ package incorporates an exposed thermal pad that is designed to be attached directly to an external heatsink. The thermal pad must be soldered directly to the printed circuit board (PCB). After soldering, the PCB can be used as a heatsink. In addition, through the use of thermal vias, the thermal pad can be attached directly to the appropriate copper plane shown in the electrical schematic for the device, or alternatively, can be attached to a special heatsink structure designed into the PCB. This design optimizes the heat transfer from the integrated circuit (IC).

For additional information on the PowerPAD package and how to take advantage of its heat dissipating abilities, refer to Technical Brief, PowerPAD Thermally Enhanced Package, Texas Instruments Literature No. SLMA002 and Application Brief, PowerPAD Made Easy, Texas Instruments Literature No. SLMA004. Both documents are available at [www.ti.com](http://www.ti.com).

The exposed thermal pad dimensions for this package are shown in the following illustration.

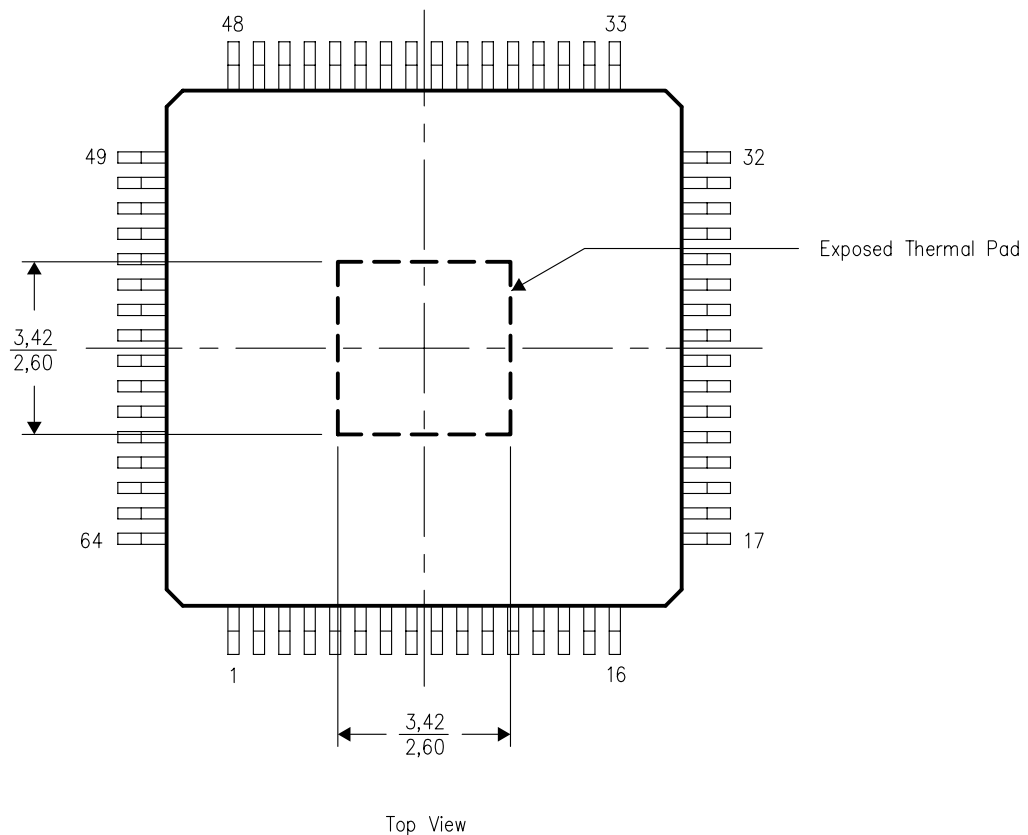

NOTE: All linear dimensions are in millimeters

Exposed Thermal Pad Dimensions

RCP (R-PVQFN-G64) PowerPAD™

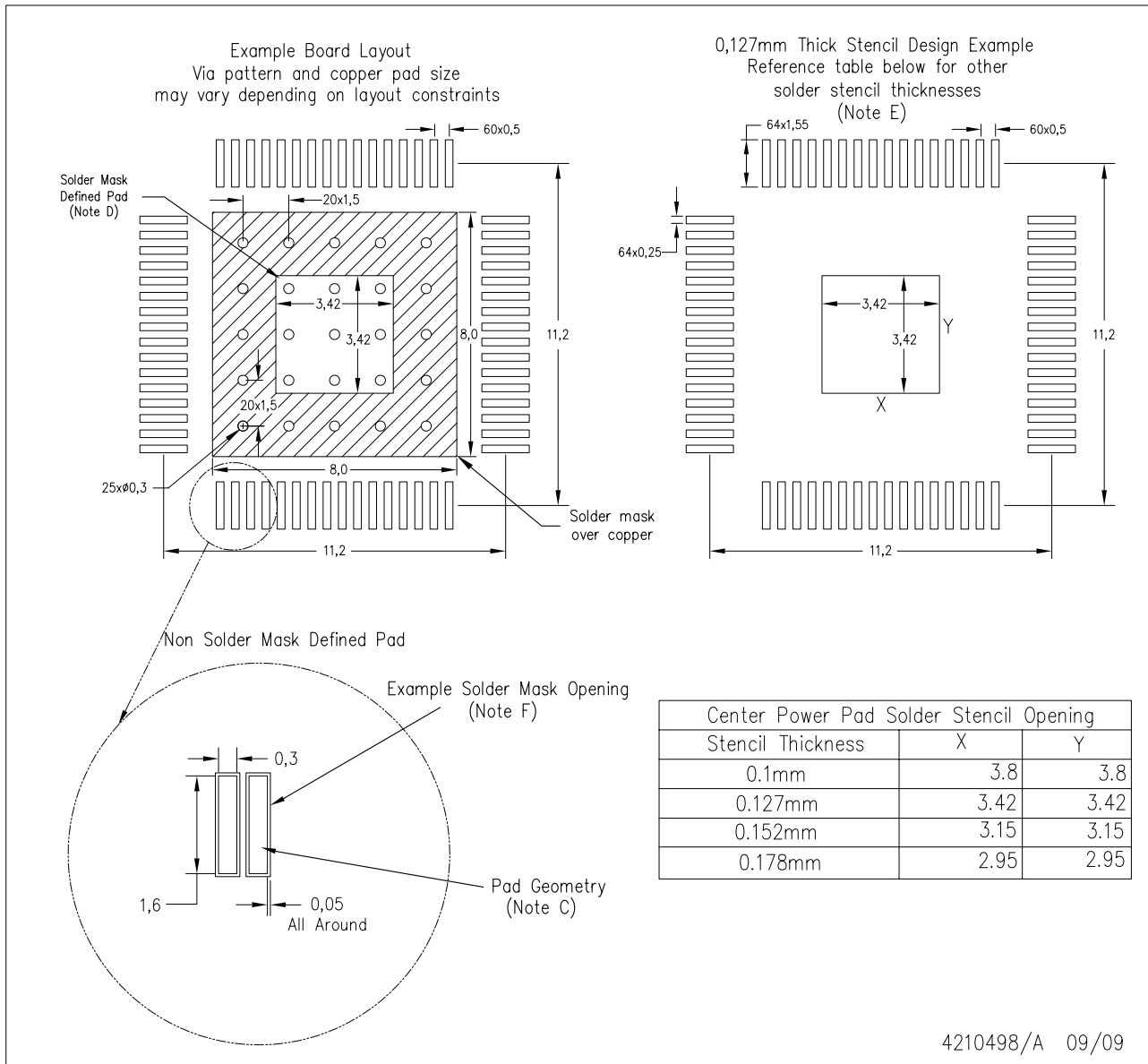

4210498/A 09/09

- NOTES:
- A. All linear dimensions are in millimeters.
  - B. This drawing is subject to change without notice.
  - C. Publication IPC-7351 is recommended for alternate designs.
  - D. This package is designed to be soldered to a thermal pad on the board. Refer to Technical Brief, PowerPad Thermally Enhanced Package, Texas Instruments Literature No. SLMA002, SLMA004, and also the Product Data Sheets for specific thermal information, via requirements, and recommended board layout. These documents are available at [www.ti.com](http://www.ti.com) <<http://www.ti.com>>.
  - E. Laser cutting apertures with trapezoidal walls and also rounding corners will offer better paste release. Customers should contact their board assembly site for stencil design recommendations. Refer to IPC 7525 for stencil design considerations.
  - F. Customers should contact their board fabrication site for recommended solder mask tolerances and via tenting options for vias placed in the thermal pad.

## IMPORTANT NOTICE

Texas Instruments Incorporated and its subsidiaries (TI) reserve the right to make corrections, enhancements, improvements and other changes to its semiconductor products and services per JESD46, latest issue, and to discontinue any product or service per JESD48, latest issue. Buyers should obtain the latest relevant information before placing orders and should verify that such information is current and complete. All semiconductor products (also referred to herein as "components") are sold subject to TI's terms and conditions of sale supplied at the time of order acknowledgment.

TI warrants performance of its components to the specifications applicable at the time of sale, in accordance with the warranty in TI's terms and conditions of sale of semiconductor products. Testing and other quality control techniques are used to the extent TI deems necessary to support this warranty. Except where mandated by applicable law, testing of all parameters of each component is not necessarily performed.

TI assumes no liability for applications assistance or the design of Buyers' products. Buyers are responsible for their products and applications using TI components. To minimize the risks associated with Buyers' products and applications, Buyers should provide adequate design and operating safeguards.

TI does not warrant or represent that any license, either express or implied, is granted under any patent right, copyright, mask work right, or other intellectual property right relating to any combination, machine, or process in which TI components or services are used. Information published by TI regarding third-party products or services does not constitute a license to use such products or services or a warranty or endorsement thereof. Use of such information may require a license from a third party under the patents or other intellectual property of the third party, or a license from TI under the patents or other intellectual property of TI.

Reproduction of significant portions of TI information in TI data books or data sheets is permissible only if reproduction is without alteration and is accompanied by all associated warranties, conditions, limitations, and notices. TI is not responsible or liable for such altered documentation. Information of third parties may be subject to additional restrictions.

Resale of TI components or services with statements different from or beyond the parameters stated by TI for that component or service voids all express and any implied warranties for the associated TI component or service and is an unfair and deceptive business practice. TI is not responsible or liable for any such statements.

Buyer acknowledges and agrees that it is solely responsible for compliance with all legal, regulatory and safety-related requirements concerning its products, and any use of TI components in its applications, notwithstanding any applications-related information or support that may be provided by TI. Buyer represents and agrees that it has all the necessary expertise to create and implement safeguards which anticipate dangerous consequences of failures, monitor failures and their consequences, lessen the likelihood of failures that might cause harm and take appropriate remedial actions. Buyer will fully indemnify TI and its representatives against any damages arising out of the use of any TI components in safety-critical applications.

In some cases, TI components may be promoted specifically to facilitate safety-related applications. With such components, TI's goal is to help enable customers to design and create their own end-product solutions that meet applicable functional safety standards and requirements. Nonetheless, such components are subject to these terms.

No TI components are authorized for use in FDA Class III (or similar life-critical medical equipment) unless authorized officers of the parties have executed a special agreement specifically governing such use.

Only those TI components which TI has specifically designated as military grade or "enhanced plastic" are designed and intended for use in military/aerospace applications or environments. Buyer acknowledges and agrees that any military or aerospace use of TI components which have **not** been so designated is solely at the Buyer's risk, and that Buyer is solely responsible for compliance with all legal and regulatory requirements in connection with such use.

TI has specifically designated certain components as meeting ISO/TS16949 requirements, mainly for automotive use. In any case of use of non-designated products, TI will not be responsible for any failure to meet ISO/TS16949.

### Products

Audio	<a href="http://www.ti.com/audio">www.ti.com/audio</a>
Amplifiers	<a href="http://amplifier.ti.com">amplifier.ti.com</a>
Data Converters	<a href="http://dataconverter.ti.com">dataconverter.ti.com</a>
DLP® Products	<a href="http://www.dlp.com">www.dlp.com</a>
DSP	<a href="http://dsp.ti.com">dsp.ti.com</a>
Clocks and Timers	<a href="http://www.ti.com/clocks">www.ti.com/clocks</a>
Interface	<a href="http://interface.ti.com">interface.ti.com</a>
Logic	<a href="http://logic.ti.com">logic.ti.com</a>
Power Mgmt	<a href="http://power.ti.com">power.ti.com</a>
Microcontrollers	<a href="http://microcontroller.ti.com">microcontroller.ti.com</a>
RFID	<a href="http://www.ti-rfid.com">www.ti-rfid.com</a>
OMAP Applications Processors	<a href="http://www.ti.com/omap">www.ti.com/omap</a>
Wireless Connectivity	<a href="http://www.ti.com/wirelessconnectivity">www.ti.com/wirelessconnectivity</a>

### Applications

Automotive and Transportation	<a href="http://www.ti.com/automotive">www.ti.com/automotive</a>
Communications and Telecom	<a href="http://www.ti.com/communications">www.ti.com/communications</a>
Computers and Peripherals	<a href="http://www.ti.com/computers">www.ti.com/computers</a>
Consumer Electronics	<a href="http://www.ti.com/consumer-apps">www.ti.com/consumer-apps</a>
Energy and Lighting	<a href="http://www.ti.com/energy">www.ti.com/energy</a>
Industrial	<a href="http://www.ti.com/industrial">www.ti.com/industrial</a>
Medical	<a href="http://www.ti.com/medical">www.ti.com/medical</a>
Security	<a href="http://www.ti.com/security">www.ti.com/security</a>
Space, Avionics and Defense	<a href="http://www.ti.com/space-avionics-defense">www.ti.com/space-avionics-defense</a>
Video and Imaging	<a href="http://www.ti.com/video">www.ti.com/video</a>

### TI E2E Community

[e2e.ti.com](http://e2e.ti.com)