

## Advanced LinCMOS™ RAIL-TO-RAIL OPERATIONAL AMPLIFIERS

### FEATURES

- Qualified for Automotive Applications
- Output Swing Includes Both Supply Rails
- Low Noise . . . 12 nV/√Hz Typ at f = 1 kHz
- Low Input Bias Current . . . 1 pA Typ
- Fully Specified for Both Single-Supply and Split-Supply Operation
- Low Power . . . 500 μA Max
- Common-Mode Input Voltage Range Includes Negative Rail
- Low Input Offset Voltage . . . 950 μV Max at T<sub>A</sub> = 25°C
- Wide Supply Voltage Range . . . 2.7 V to 8 V
- Macromodel Included

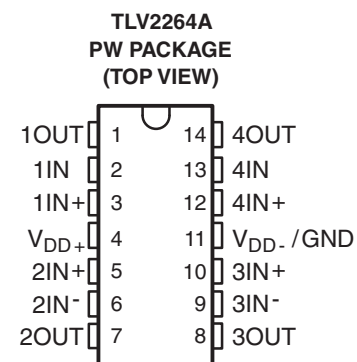
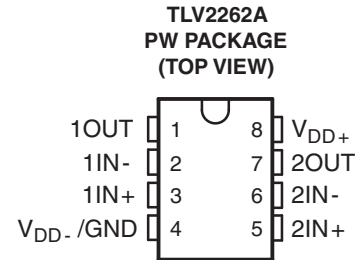

### DESCRIPTION

The TLV2262 and TLV2264 are dual and quad low voltage operational amplifiers from Texas Instruments. Both devices exhibit rail-to-rail output performance for increased dynamic range in single or split supply applications. The TLV226x family offers a compromise between the micropower TLV225x and the ac performance of the TLC227x. It has low supply current for battery-powered applications, while still having adequate ac performance for applications that demand it. This family is fully characterized at 3 V and 5 V and is optimized for low-voltage applications. The noise performance has been dramatically improved over previous generations of CMOS amplifiers. [Figure 1](#) depicts the low level of noise voltage for this CMOS amplifier, which has only 200 μA (typ) of supply current per amplifier.



Please be aware that an important notice concerning availability, standard warranty, and use in critical applications of Texas Instruments semiconductor products and disclaimers thereto appears at the end of this data sheet.

Advanced LinCMOS is a trademark of Texas Instruments.  
Parts, PSpice are trademarks of MicroSim Corporation.

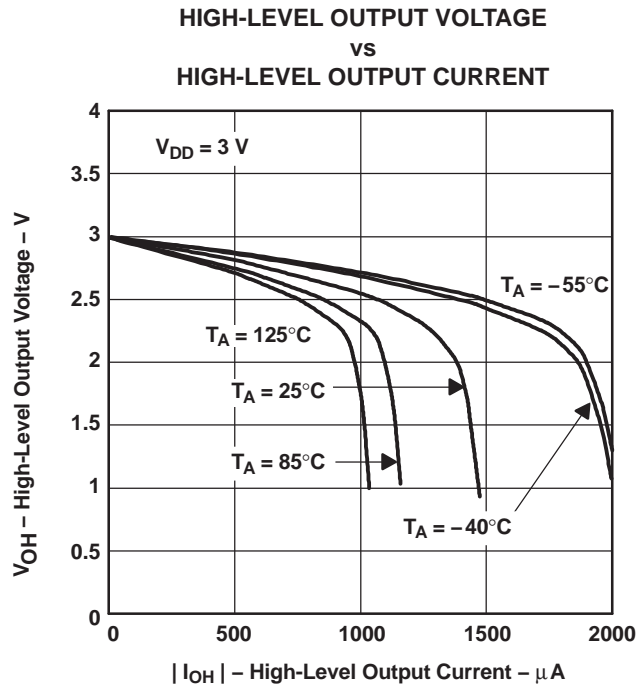

The TLV226x, exhibiting high input impedance and low noise, are excellent for small-signal conditioning for high-impedance sources, such as piezoelectric transducers. Because of the micropower dissipation levels combined with 3-V operation, these devices work well in hand-held monitoring and remote-sensing applications. In addition, the rail-to-rail output feature with single or split supplies makes this family a great choice when interfacing with analog-to-digital converters (ADCs). For precision applications, the TLV226xA family is available and has a maximum input offset voltage of 950  $\mu$ V.

The TLV2262/4 also makes great upgrades to the TLV2332/4 in standard designs. They offer increased output dynamic range, lower noise voltage and lower input offset voltage. This enhanced feature set allows them to be used in a wider range of applications. For applications that require higher output drive and wider input voltage range, see the TLV2432 and TLV2442 devices. If your design requires single amplifiers, please see the TLV2211/21/31 family. These devices are single rail-to-rail operational amplifiers in the SOT-23 package. Their small size and low power consumption make them ideal for high density, battery-powered equipment.

**ORDERING INFORMATION<sup>(1)</sup>**

| $T_A$          | PACKAGE <sup>(2)</sup> |              | ORDERABLE PART NUMBER | TOP-SIDE MARKING |
|----------------|------------------------|--------------|-----------------------|------------------|
| -40°C to 125°C | TSSOP – PW (8 pin)     | Reel of 2000 | TLV2262AQPWRQ1        | TQ262A           |
|                | TSSOP – PW (14 pin)    | Reel of 2000 | TLV2264AQPWRQ1        | P2264AQ          |

(1) For the most current package and ordering information, see the Package Option Addendum at the end of this document, or see the TI web site at [www.ti.com](http://www.ti.com).

(2) Package drawings, thermal data, and symbolization are available at [www.ti.com/packaging](http://www.ti.com/packaging).

EQUIVALENT SCHEMATIC (EACH AMPLIFIER)

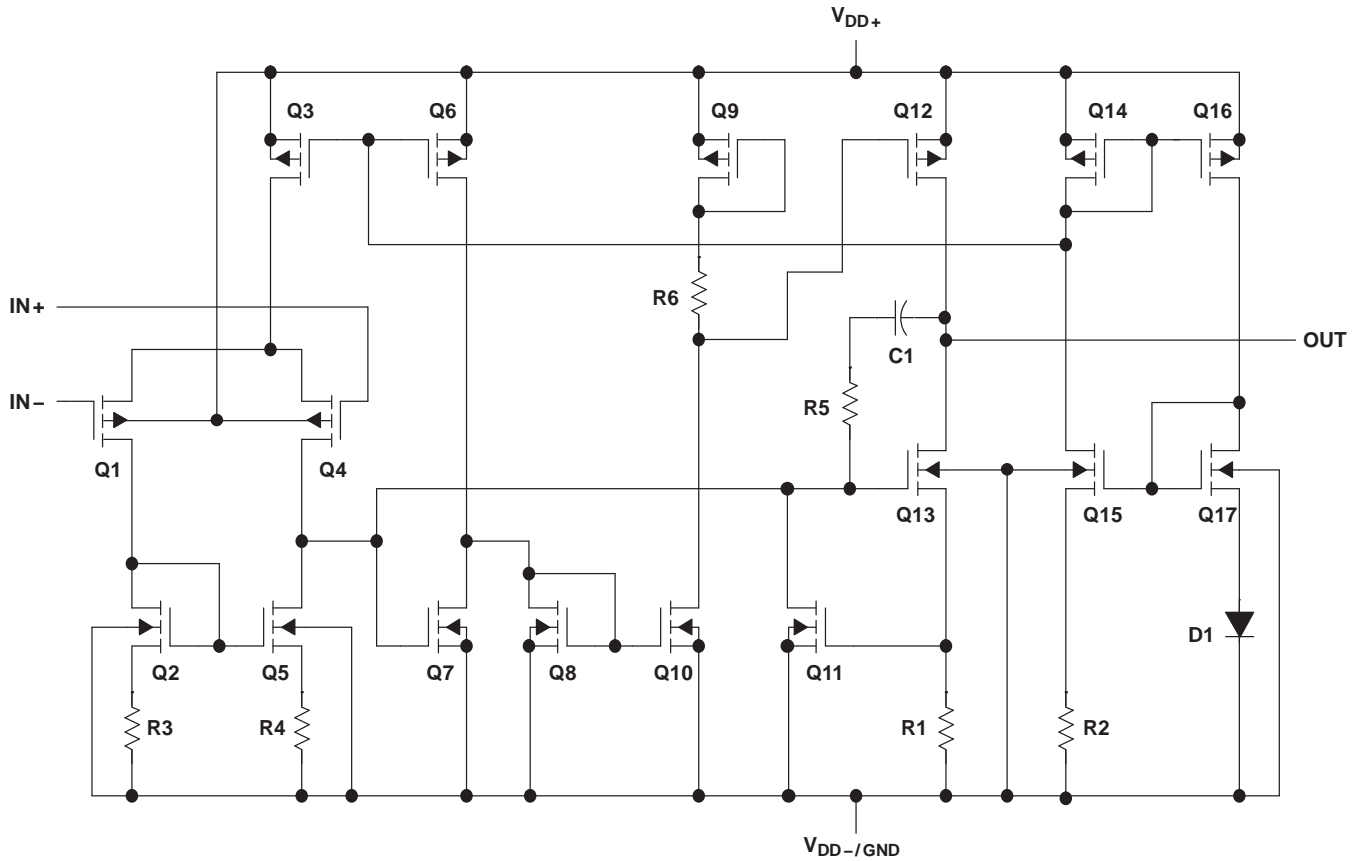

Table 1. Actual Device Component Count

| COMPONENT   | TLV2262 | TLV2264 |
|-------------|---------|---------|
| Transistors | 38      | 76      |
| Resistors   | 28      | 54      |
| Diodes      | 9       | 18      |
| Capacitors  | 3       | 6       |

### ABSOLUTE MAXIMUM RATINGS<sup>(1)</sup>

over operating free-air temperature range (unless otherwise noted)

|           |   |  |
|-----------|---|--|
| $V_{DD}$  | Supply voltage <sup>(2)</sup>                                       | -0.3 V to 16 V                           |
| $V_{ID}$  | Differential input voltage <sup>(3)</sup>                           | $\pm V_{DD}$                             |
| $V_I$     | Input voltage range   | $(V_{DD-} - 0.3 \text{ V})$ to $V_{DD+}$ |
| $I_I$     | Input current, any input  | $\pm 5 \text{ mA}$                       |
| $I_O$     | Output current  | $\pm 50 \text{ mA}$                      |
|           | Total current into $V_{DD+}$  | $\pm 50 \text{ mA}$                      |
|           | Total current out of $V_{DD-}$                                      | $\pm 50 \text{ mA}$                      |
|           | Duration of short-circuit current (at or below) 25°C <sup>(4)</sup> | Unlimited                                |
| $P_D$     | Continuous total power dissipation                                  | See Dissipation Rating Table             |
| $T_A$     | Operating free-air temperature range                                | -40°C to 125°C                           |
| $T_{stg}$ | Storage temperature range   | -65°C to 150°C                           |

- (1) Stresses beyond those listed under *absolute maximum ratings* may cause permanent damage to the device. These are stress ratings only, and functional operation of the device at these or any other conditions beyond those indicated under *recommended operating conditions* is not implied. Exposure to absolute-maximum-rated conditions for extended periods may affect device reliability.
- (2) All voltage values, except differential voltages, are with respect to  $V_{DD-}$ .
- (3) Differential voltages are at the noninverting input with respect to the inverting input. Excessive current flows when input is brought below  $V_{DD-} - 0.3 \text{ V}$ .
- (4) The output may be shorted to either supply. Temperature and/or supply voltages must be limited to ensure that the maximum dissipation rating is not exceeded.

### DISSIPATION RATINGS

| PACKAGE | $T_A \leq 25^\circ\text{C}$<br>POWER RATING | DERATING FACTOR<br>ABOVE $T_A = 25^\circ\text{C}$ | $T_A = 85^\circ\text{C}$<br>POWER RATING | $T_A = 125^\circ\text{C}$<br>POWER RATING |
|---------|---|---|--|---|
| PW-8    | 525 mW                                      | 4.2 mW/°C   | 273 mW                                   | 105 mW                                    |
| PW-14   | 700 mW                                      | 5.6 mW/°C   | 364 mW                                   | 140 mW                                    |

### RECOMMENDED OPERATING CONDITIONS

|   | MIN       | MAX             | UNIT |
|---|-----------|-----------------|------|
| $V_{DD\pm}$ Supply voltage <sup>(1)</sup> | 2.7       | 8               | V    |
| $V_I$ Input voltage                       | $V_{DD-}$ | $V_{DD+} - 1.3$ | V    |
| $V_{IC}$ Common-mode input voltage        | $V_{DD-}$ | $V_{DD+} - 1.3$ | V    |
| $T_A$ Operating free-air temperature      | -40       | 125             | °C   |

- (1) All voltage values, except differential voltages, are with respect to  $V_{DD-}$ .

**TLV2262A ELECTRICAL CHARACTERISTICS**
 $V_{DD} = 3\text{ V}$ , over operating free-air temperature range (unless otherwise noted)

| PARAMETER      |  | TEST CONDITIONS   |  | $T_A$         | MIN      | TYP         | MAX  | UNIT                         |
|----------------|--|---|--|---------------|----------|-------------|------|------------------------------|
| $V_{IO}$       | Input offset voltage   | $V_{DD\pm} = \pm 1.5\text{ V}$ , $V_{IC} = 0$ , $V_O = 0$ , $R_S = 50\ \Omega$  |  | 25°C          |          | 300         | 950  | mV                           |
|                |  |   |  | Full range    |          |             | 1500 |                              |
| $\alpha_{VIO}$ | Temperature coefficient of input offset voltage                  | $V_{DD\pm} = \pm 1.5\text{ V}$ , $V_{IC} = 0$ , $V_O = 0$ , $R_S = 50\ \Omega$  |  | 25°C to 125°C |          | 2           |      | $\mu\text{V}/^\circ\text{C}$ |
|                | Input offset voltage long-term drift <sup>(1)</sup>              | $V_{DD\pm} = \pm 1.5\text{ V}$ , $V_{IC} = 0$ , $V_O = 0$ , $R_S = 50\ \Omega$  |  | 25°C          |          | 0.003       |      | $\mu\text{V}/\text{mo}$      |
| $I_{IO}$       | Input offset current   | $V_{DD\pm} = \pm 1.5\text{ V}$ , $V_{IC} = 0$ , $V_O = 0$ , $R_S = 50\ \Omega$  |  | 25°C          |          | 0.5         | 60   | pA                           |
|                |  |   |  | 125°C         |          |             | 800  |                              |
| $I_{IB}$       | Input bias current   | $V_{DD\pm} = \pm 1.5\text{ V}$ , $V_{IC} = 0$ , $V_O = 0$ , $R_S = 50\ \Omega$  |  | 25°C          |          | 1           | 60   | pA                           |
|                |  |   |  | 125°C         |          |             | 800  |                              |
| $V_{ICR}$      | Common-mode input voltage range                                  | $R_S = 50\ \Omega$ , $ V_{IO}  \leq 5\text{ mV}$                                |  | 25°C          | 0 to 2   | -0.3 to 2.2 |      | V                            |
|                |  |   |  | Full range    | 0 to 1.7 |             |      |                              |
| $V_{OH}$       | High-level output voltage  |   |  | 25°C          |          | 2.99        |      | V                            |
|                |  |   |  | 25°C          |          | 2.85        |      |                              |
|                |  |   |  | Full range    |          | 2.82        |      |                              |
|                |  |   |  | 25°C          |          | 2.7         |      |                              |
| $V_{OL}$       | Low-level output voltage   | $V_{IC} = 1.5\text{ V}$   |  | 25°C          |          | 10          |      | mV                           |
|                |  |   |  | 25°C          |          | 100         | 150  |                              |
|                |  |   |  | Full range    |          |             | 165  |                              |
|                |  |   |  | 25°C          |          | 200         | 300  |                              |
| $A_{VD}$       | Large-signal differential voltage amplification                  | $V_{IC} = 1.5\text{ V}$ , $V_O = 1\text{ V to }2\text{ V}$                      |  | 25°C          |          | 60          | 100  | V/mV                         |
|                |  |   |  | Full range    |          | 25          |      |                              |
|                |  |   |  | 25°C          |          | 100         |      |                              |
|                |  |   |  | Full range    |          |             | 300  |                              |
| $r_{i(d)}$     | Differential input resistance                                    |   |  | 25°C          |          | $10^{12}$   |      | $\Omega$                     |
| $r_{i(c)}$     | Common-mode input resistance                                     |   |  | 25°C          |          | $10^{12}$   |      | $\Omega$                     |
| $C_{i(c)}$     | Common-mode input capacitance                                    | $f = 10\text{ kHz}$   |  | 25°C          |          | 8           |      | pF                           |
| $Z_o$          | Closed-loop output impedance                                     | $f = 100\text{ kHz}$ , $A_V = 10$   |  | 25°C          |          | 270         |      | $\Omega$                     |
| CMRR           | Common-mode rejection ratio                                      | $V_{IC} = 0\text{ to }1.7\text{ V}$ , $V_O = 1.5\text{ V}$ , $R_S = 50\ \Omega$ |  | 25°C          |          | 65          | 77   | dB                           |
|                |  |   |  | Full range    |          | 60          |      |                              |
| $k_{SVR}$      | Supply voltage rejection ratio ( $\Delta V_{DD}/\Delta V_{IO}$ ) | $V_{DD} = 2.7\text{ V to }8\text{ V}$ , $V_{IC} = V_{DD}/2$ , No load           |  | 25°C          |          | 80          | 100  | dB                           |
|                |  |   |  | Full range    |          | 80          |      |                              |
| $I_{DD}$       | Supply current   | $V_O = 1.5\text{ V}$ , No load  |  | 25°C          |          | 400         | 500  | $\mu\text{A}$                |
|                |  |   |  | Full range    |          |             | 500  |                              |

(1) Typical values are based on the input offset voltage shift observed through 500 hours of operating life test at  $T_A = 150^\circ\text{C}$  extrapolated to  $T_A = 25^\circ\text{C}$  using the Arrhenius equation and assuming an activation energy of 0.96 eV.

(2) Referenced to 1.5 V

**TLV2262A OPERATING CHARACTERISTICS**

V<sub>DD</sub> = 3 V, over operating free-air temperature range (unless otherwise noted)

| PARAMETER          |   | TEST CONDITIONS   | T <sub>A</sub>      | MIN  | TYP  | MAX | UNIT   |
|--------------------|---|---|---------------------|------|------|-----|--------|
| SR                 | Slew rate at unity gain                     | V <sub>O</sub> = 0.5 V to 1.7 V, R <sub>L</sub> = 50 kΩ <sup>(1)</sup> ,<br>C <sub>L</sub> = 100 pF <sup>(1)</sup>              | 25°C                | 0.35 | 0.55 |     | V/μs   |
|                    |   |   | Full range          | 0.25 |      |     |        |
| V <sub>n</sub>     | Equivalent input noise voltage              | f = 10 Hz   | 25°C                | 43   |      |     | nV/√Hz |
|                    |   | f = 1 kHz   | 25°C                | 12   |      |     |        |
| V <sub>N(PP)</sub> | Peak-to-peak equivalent input noise voltage | f = 0.1 Hz to 1 Hz  | 25°C                | 0.6  |      |     | μV     |
|                    |   | f = 0.1 Hz to 10 Hz   | 25°C                | 1    |      |     |        |
| I <sub>n</sub>     | Equivalent input noise current              |   | 25°C                | 0.6  |      |     | fA/√Hz |
| THD+N              | Total harmonic distortion plus noise        | V <sub>O</sub> = 0.5 V to 2.5 V, f = 20 kHz,<br>R <sub>L</sub> = 50 kΩ <sup>(1)</sup>   | A <sub>V</sub> = 1  | 25°C | 0.03 |     | %      |
|                    |   |   | A <sub>V</sub> = 10 | 25°C | 0.05 |     |        |
|                    | Gain-bandwidth product                      | f = 1 kHz, R <sub>L</sub> = 50 kΩ <sup>(1)</sup> , C <sub>L</sub> = 100 pF <sup>(1)</sup>                                       | 25°C                | 0.67 |      |     | MHz    |
| B <sub>OM</sub>    | Maximum output-swing bandwidth              | V <sub>O(PP)</sub> = 1 V, A <sub>V</sub> = 1, R <sub>L</sub> = 50 kΩ <sup>(1)</sup> ,<br>C <sub>L</sub> = 100 pF <sup>(1)</sup> | 25°C                | 395  |      |     | kHz    |
| t <sub>s</sub>     | Settling time                               | A <sub>V</sub> = -1, Step = 1 V to 2 V,<br>R <sub>L</sub> = 50 kΩ <sup>(1)</sup> , C <sub>L</sub> = 100 pF <sup>(1)</sup>       | To 0.1%             | 25°C | 5.6  |     | μs     |
|                    |   |   | To 0.01%            | 25°C | 12.5 |     |        |
| φ <sub>m</sub>     | Phase margin at unity gain                  | R <sub>L</sub> = 50 kΩ <sup>(1)</sup> , C <sub>L</sub> = 100 pF <sup>(1)</sup>  | 25°C                | 55   |      |     | °      |
| G <sub>m</sub>     | Gain margin                                 | R <sub>L</sub> = 50 kΩ <sup>(1)</sup> , C <sub>L</sub> = 100 pF <sup>(1)</sup>  | 25°C                | 11   |      |     | dB     |

(1) Referenced to 1.5 V

**TLV2262A ELECTRICAL CHARACTERISTICS**
 $V_{DD} = 5\text{ V}$ , over operating free-air temperature range (unless otherwise noted)

| PARAMETER      |  | TEST CONDITIONS   |  | $T_A$         | MIN      | TYP         | MAX  | UNIT                         |
|----------------|--|---|--|---------------|----------|-------------|------|------------------------------|
| $V_{IO}$       | Input offset voltage   | $V_{DD\pm} = \pm 2.5\text{ V}$ , $V_{IC} = 0$ , $V_O = 0$ , $R_S = 50\ \Omega$  |  | 25°C          |          | 300         | 950  | mV                           |
|                |  |   |  | Full range    |          |             | 1500 |                              |
| $\alpha_{VIO}$ | Temperature coefficient of input offset voltage                  | $V_{DD\pm} = \pm 2.5\text{ V}$ , $V_{IC} = 0$ , $V_O = 0$ , $R_S = 50\ \Omega$  |  | 25°C to 125°C |          | 2           |      | $\mu\text{V}/^\circ\text{C}$ |
|                | Input offset voltage long-term drift <sup>(1)</sup>              | $V_{DD\pm} = \pm 2.5\text{ V}$ , $V_{IC} = 0$ , $V_O = 0$ , $R_S = 50\ \Omega$  |  | 25°C          |          | 0.003       |      | $\mu\text{V}/\text{mo}$      |
| $I_{IO}$       | Input offset current   | $V_{DD\pm} = \pm 2.5\text{ V}$ , $V_{IC} = 0$ , $V_O = 0$ , $R_S = 50\ \Omega$  |  | 25°C          |          | 0.5         | 60   | pA                           |
|                |  |   |  | 125°C         |          |             | 800  |                              |
| $I_{IB}$       | Input bias current   | $V_{DD\pm} = \pm 2.5\text{ V}$ , $V_{IC} = 0$ , $V_O = 0$ , $R_S = 50\ \Omega$  |  | 25°C          |          | 1           | 60   | pA                           |
|                |  |   |  | 125°C         |          |             | 800  |                              |
| $V_{ICR}$      | Common-mode input voltage range                                  | $R_S = 50\ \Omega$ , $ V_{IO}  \leq 5\text{ mV}$                                |  | 25°C          | 0 to 4   | -0.3 to 4.2 |      | V                            |
|                |  |   |  | Full range    | 0 to 3.5 |             |      |                              |
| $V_{OH}$       | High-level output voltage  |   |  | 25°C          |          | 4.99        |      | V                            |
|                |  |   |  | 25°C          |          | 4.85        | 4.94 |                              |
|                |  |   |  | Full range    |          | 4.82        |      |                              |
|                |  |   |  | 25°C          |          | 4.7         | 4.85 |                              |
| $V_{OL}$       | Low-level output voltage   | $V_{IC} = 2.5\text{ V}$   |  | 25°C          |          | 0.01        |      | V                            |
|                |  |   |  | 25°C          |          | 0.09        | 0.15 |                              |
|                |  |   |  | Full range    |          |             | 0.15 |                              |
|                |  |   |  | 25°C          |          | 0.2         | 0.3  |                              |
| $A_{VD}$       | Large-signal differential voltage amplification                  | $V_{IC} = 2.5\text{ V}$ , $V_O = 1\text{ V to }4\text{ V}$                      |  | 25°C          |          | 80          | 170  | V/mV                         |
|                |  |   |  | Full range    |          | 50          |      |                              |
|                |  |   |  | 25°C          |          | 550         |      |                              |
|                |  |   |  | Full range    |          |             | 0.3  |                              |
| $r_{i(d)}$     | Differential input resistance                                    |   |  | 25°C          |          | $10^{12}$   |      | $\Omega$                     |
| $r_{i(c)}$     | Common-mode input resistance                                     |   |  | 25°C          |          | $10^{12}$   |      | $\Omega$                     |
| $C_{i(c)}$     | Common-mode input capacitance                                    | $f = 10\text{ kHz}$   |  | 25°C          |          | 8           |      | pF                           |
| $Z_o$          | Closed-loop output impedance                                     | $f = 100\text{ kHz}$ , $A_V = 10$   |  | 25°C          |          | 240         |      | $\Omega$                     |
| CMRR           | Common-mode rejection ratio                                      | $V_{IC} = 0\text{ to }2.7\text{ V}$ , $V_O = 2.5\text{ V}$ , $R_S = 50\ \Omega$ |  | 25°C          |          | 70          | 83   | dB                           |
|                |  |   |  | Full range    |          | 70          |      |                              |
| $k_{SVR}$      | Supply voltage rejection ratio ( $\Delta V_{DD}/\Delta V_{IO}$ ) | $V_{DD} = 4.4\text{ V to }8\text{ V}$ , $V_{IC} = V_{DD}/2$ , No load           |  | 25°C          |          | 80          | 95   | dB                           |
|                |  |   |  | Full range    |          | 80          |      |                              |
| $I_{DD}$       | Supply current   | $V_O = 2.5\text{ V}$ , No load  |  | 25°C          |          | 400         | 500  | $\mu\text{A}$                |
|                |  |   |  | Full range    |          |             | 500  |                              |

(1) Typical values are based on the input offset voltage shift observed through 500 hours of operating life test at  $T_A = 150^\circ\text{C}$  extrapolated to  $T_A = 25^\circ\text{C}$  using the Arrhenius equation and assuming an activation energy of 0.96 eV.

(2) Referenced to 2.5 V

### TLV2262A OPERATING CHARACTERISTICS

V<sub>DD</sub> = 5 V, over operating free-air temperature range (unless otherwise noted)

| PARAMETER          |   | TEST CONDITIONS   | T <sub>A</sub>      | MIN  | TYP  | MAX   | UNIT   |
|--------------------|---|---|---------------------|------|------|-------|--------|
| SR                 | Slew rate at unity gain                     | V <sub>O</sub> = 0.5 V to 3.5 V, R <sub>L</sub> = 50 kΩ <sup>(1)</sup> ,<br>C <sub>L</sub> = 100 pF <sup>(1)</sup>              | 25°C                | 0.35 | 0.55 |       | V/μs   |
|                    |   |   | Full range          | 0.25 |      |       |        |
| V <sub>n</sub>     | Equivalent input noise voltage              | f = 10 Hz   | 25°C                |      | 40   |       | nV/√Hz |
|                    |   | f = 1 kHz   | 25°C                |      | 12   |       |        |
| V <sub>N(PP)</sub> | Peak-to-peak equivalent input noise voltage | f = 0.1 Hz to 1 Hz  | 25°C                |      | 0.7  |       | μV     |
|                    |   | f = 0.1 Hz to 10 Hz   | 25°C                |      | 1.3  |       |        |
| I <sub>n</sub>     | Equivalent input noise current              |   | 25°C                |      | 0.6  |       | fA/√Hz |
| THD+N              | Total harmonic distortion plus noise        | V <sub>O</sub> = 0.5 V to 2.5 V, f = 20 kHz,<br>R <sub>L</sub> = 50 kΩ <sup>(1)</sup>   | A <sub>V</sub> = 1  | 25°C |      | 0.017 | %      |
|                    |   |   | A <sub>V</sub> = 10 | 25°C |      | 0.03  |        |
|                    | Gain-bandwidth product                      | f = 50 kHz, R <sub>L</sub> = 50 kΩ <sup>(1)</sup> , C <sub>L</sub> = 100 pF <sup>(1)</sup>                                      | 25°C                |      | 0.71 |       | MHz    |
| B <sub>OM</sub>    | Maximum output-swing bandwidth              | V <sub>O(PP)</sub> = 2 V, A <sub>V</sub> = 1, R <sub>L</sub> = 50 kΩ <sup>(1)</sup> ,<br>C <sub>L</sub> = 100 pF <sup>(1)</sup> | 25°C                |      | 185  |       | kHz    |
| t <sub>s</sub>     | Settling time                               | A <sub>V</sub> = -1, Step = 0.5 V to 2.5 V,<br>R <sub>L</sub> = 50 kΩ <sup>(1)</sup> , C <sub>L</sub> = 100 pF <sup>(1)</sup>   | To 0.1%             | 25°C |      | 6.4   | μs     |
|                    |   |   | To 0.01%            | 25°C |      | 14.1  |        |
| φ <sub>m</sub>     | Phase margin at unity gain                  | R <sub>L</sub> = 50 kΩ <sup>(1)</sup> , C <sub>L</sub> = 100 pF <sup>(1)</sup>  | 25°C                |      | 56   |       | °      |
| G <sub>m</sub>     | Gain margin                                 | R <sub>L</sub> = 50 kΩ <sup>(1)</sup> , C <sub>L</sub> = 100 pF <sup>(1)</sup>  | 25°C                |      | 11   |       | dB     |

(1) Referenced to 2.5 V

**TLV2264A ELECTRICAL CHARACTERISTICS**
 $V_{DD} = 3\text{ V}$ , over operating free-air temperature range (unless otherwise noted)

| PARAMETER      |  | TEST CONDITIONS   |  | $T_A$         | MIN      | TYP         | MAX  | UNIT                         |
|----------------|--|---|--|---------------|----------|-------------|------|------------------------------|
| $V_{IO}$       | Input offset voltage   | $V_{DD\pm} = \pm 1.5\text{ V}$ , $V_{IC} = 0$ , $V_O = 0$ , $R_S = 50\ \Omega$  |  | 25°C          |          | 300         | 950  | mV                           |
|                |  |   |  | Full range    |          |             | 1500 |                              |
| $\alpha_{VIO}$ | Temperature coefficient of input offset voltage                  | $V_{DD\pm} = \pm 1.5\text{ V}$ , $V_{IC} = 0$ , $V_O = 0$ , $R_S = 50\ \Omega$  |  | 25°C to 125°C |          | 2           |      | $\mu\text{V}/^\circ\text{C}$ |
|                | Input offset voltage long-term drift <sup>(1)</sup>              | $V_{DD\pm} = \pm 1.5\text{ V}$ , $V_{IC} = 0$ , $V_O = 0$ , $R_S = 50\ \Omega$  |  | 25°C          |          | 0.003       |      | $\mu\text{V}/\text{mo}$      |
| $I_{IO}$       | Input offset current   | $V_{DD\pm} = \pm 1.5\text{ V}$ , $V_{IC} = 0$ , $V_O = 0$ , $R_S = 50\ \Omega$  |  | 25°C          |          | 0.5         | 60   | pA                           |
|                |  |   |  | 125°C         |          |             | 800  |                              |
| $I_{IB}$       | Input bias current   | $V_{DD\pm} = \pm 1.5\text{ V}$ , $V_{IC} = 0$ , $V_O = 0$ , $R_S = 50\ \Omega$  |  | 25°C          |          | 1           | 60   | pA                           |
|                |  |   |  | 125°C         |          |             | 800  |                              |
| $V_{ICR}$      | Common-mode input voltage range                                  | $R_S = 50\ \Omega$ , $ V_{IO}  \leq 5\text{ mV}$                                |  | 25°C          | 0 to 2   | -0.3 to 2.2 |      | V                            |
|                |  |   |  | Full range    | 0 to 1.7 |             |      |                              |
| $V_{OH}$       | High-level output voltage  |   |  | 25°C          |          | 2.99        |      | V                            |
|                |  |   |  | 25°C          |          | 2.85        |      |                              |
|                |  |   |  | Full range    |          | 2.82        |      |                              |
|                |  |   |  | 25°C          |          | 2.7         |      |                              |
| $V_{OL}$       | Low-level output voltage   | $V_{IC} = 1.5\text{ V}$   |  | 25°C          |          | 10          |      | mV                           |
|                |  |   |  | 25°C          |          | 100         | 150  |                              |
|                |  |   |  | Full range    |          |             | 150  |                              |
|                |  |   |  | 25°C          |          | 200         | 300  |                              |
| $A_{VD}$       | Large-signal differential voltage amplification                  | $V_{IC} = 1.5\text{ V}$ , $V_O = 1\text{ V to }2\text{ V}$                      |  | 25°C          |          | 60          | 100  | V/mV                         |
|                |  |   |  | Full range    |          | 25          |      |                              |
|                |  |   |  | 25°C          |          | 100         |      |                              |
|                |  |   |  | Full range    |          |             | 300  |                              |
| $r_{i(d)}$     | Differential input resistance                                    |   |  | 25°C          |          | $10^{12}$   |      | $\Omega$                     |
| $r_{i(c)}$     | Common-mode input resistance                                     |   |  | 25°C          |          | $10^{12}$   |      | $\Omega$                     |
| $C_{i(c)}$     | Common-mode input capacitance                                    | $f = 10\text{ kHz}$   |  | 25°C          |          | 8           |      | pF                           |
| $Z_o$          | Closed-loop output impedance                                     | $f = 100\text{ kHz}$ , $A_V = 10$   |  | 25°C          |          | 270         |      | $\Omega$                     |
| CMRR           | Common-mode rejection ratio                                      | $V_{IC} = 0\text{ to }1.7\text{ V}$ , $V_O = 1.5\text{ V}$ , $R_S = 50\ \Omega$ |  | 25°C          |          | 65          | 77   | dB                           |
|                |  |   |  | Full range    |          | 60          |      |                              |
| $k_{SVR}$      | Supply voltage rejection ratio ( $\Delta V_{DD}/\Delta V_{IO}$ ) | $V_{DD} = 2.7\text{ V to }8\text{ V}$ , $V_{IC} = V_{DD}/2$ , No load           |  | 25°C          |          | 80          | 100  | dB                           |
|                |  |   |  | Full range    |          | 80          |      |                              |
| $I_{DD}$       | Supply current   | $V_O = 1.5\text{ V}$ , No load  |  | 25°C          |          | 0.8         | 1    | mA                           |
|                |  |   |  | Full range    |          |             | 1    |                              |

(1) Typical values are based on the input offset voltage shift observed through 500 hours of operating life test at  $T_A = 150^\circ\text{C}$  extrapolated to  $T_A = 25^\circ\text{C}$  using the Arrhenius equation and assuming an activation energy of 0.96 eV.

(2) Referenced to 1.5 V

**TLV2264A OPERATING CHARACTERISTICS**

V<sub>DD</sub> = 3 V, over operating free-air temperature range (unless otherwise noted)

| PARAMETER          |   | TEST CONDITIONS   | T <sub>A</sub>      | MIN  | TYP  | MAX  | UNIT   |
|--------------------|---|---|---------------------|------|------|------|--------|
| SR                 | Slew rate at unity gain                     | V <sub>O</sub> = 0.5 V to 1.7 V, R <sub>L</sub> = 50 kΩ <sup>(1)</sup> ,<br>C <sub>L</sub> = 100 pF <sup>(1)</sup>              | 25°C                | 0.35 | 0.55 |      | V/μs   |
|                    |   |   | Full range          | 0.25 |      |      |        |
| V <sub>n</sub>     | Equivalent input noise voltage              | f = 10 Hz   | 25°C                |      | 43   |      | nV/√Hz |
|                    |   | f = 1 kHz   | 25°C                |      | 12   |      |        |
| V <sub>N(PP)</sub> | Peak-to-peak equivalent input noise voltage | f = 0.1 Hz to 1 Hz  | 25°C                |      | 0.6  |      | μV     |
|                    |   | f = 0.1 Hz to 10 Hz   | 25°C                |      | 1    |      |        |
| I <sub>n</sub>     | Equivalent input noise current              |   | 25°C                |      | 0.6  |      | fA/√Hz |
| THD+N              | Total harmonic distortion plus noise        | V <sub>O</sub> = 0.5 V to 2.5 V, f = 20 kHz,<br>R <sub>L</sub> = 50 kΩ <sup>(1)</sup>   | A <sub>V</sub> = 1  | 25°C |      | 0.03 | %      |
|                    |   |   | A <sub>V</sub> = 10 | 25°C |      | 0.05 |        |
|                    | Gain-bandwidth product                      | f = 1 kHz, R <sub>L</sub> = 50 kΩ <sup>(1)</sup> , C <sub>L</sub> = 100 pF <sup>(1)</sup>                                       | 25°C                |      | 0.67 |      | MHz    |
| B <sub>OM</sub>    | Maximum output-swing bandwidth              | V <sub>O(PP)</sub> = 1 V, A <sub>V</sub> = 1, R <sub>L</sub> = 50 kΩ <sup>(1)</sup> ,<br>C <sub>L</sub> = 100 pF <sup>(1)</sup> | 25°C                |      | 395  |      | kHz    |
| t <sub>s</sub>     | Settling time                               | A <sub>V</sub> = -1, Step = 1 V to 2 V,<br>R <sub>L</sub> = 50 kΩ <sup>(1)</sup> , C <sub>L</sub> = 100 pF <sup>(1)</sup>       | To 0.1%             | 25°C |      | 5.6  | μs     |
|                    |   |   | To 0.01%            | 25°C |      | 12.5 |        |
| φ <sub>m</sub>     | Phase margin at unity gain                  | R <sub>L</sub> = 50 kΩ <sup>(1)</sup> , C <sub>L</sub> = 100 pF <sup>(1)</sup>  | 25°C                |      | 55   |      | °      |
| G <sub>m</sub>     | Gain margin                                 | R <sub>L</sub> = 50 kΩ <sup>(1)</sup> , C <sub>L</sub> = 100 pF <sup>(1)</sup>  | 25°C                |      | 11   |      | dB     |

(1) Referenced to 1.5 V

**TLV2264A ELECTRICAL CHARACTERISTICS**
 $V_{DD} = 5\text{ V}$ , over operating free-air temperature range (unless otherwise noted)

| PARAMETER      |  | TEST CONDITIONS   |  | $T_A$         | MIN                             | TYP         | MAX  | UNIT                         |
|----------------|--|---|--|---------------|---------------------------------|-------------|------|------------------------------|
| $V_{IO}$       | Input offset voltage   | $V_{DD\pm} = \pm 2.5\text{ V}$ , $V_{IC} = 0$ , $V_O = 0$ , $R_S = 50\ \Omega$  |  | 25°C          |                                 | 300         | 950  | mV                           |
|                |  |   |  | Full range    |                                 |             | 1500 |                              |
| $\alpha_{VIO}$ | Temperature coefficient of input offset voltage                  | $V_{DD\pm} = \pm 2.5\text{ V}$ , $V_{IC} = 0$ , $V_O = 0$ , $R_S = 50\ \Omega$  |  | 25°C to 125°C |                                 | 2           |      | $\mu\text{V}/^\circ\text{C}$ |
|                | Input offset voltage long-term drift <sup>(1)</sup>              | $V_{DD\pm} = \pm 2.5\text{ V}$ , $V_{IC} = 0$ , $V_O = 0$ , $R_S = 50\ \Omega$  |  | 25°C          |                                 | 0.003       |      | $\mu\text{V}/\text{mo}$      |
| $I_{IO}$       | Input offset current   | $V_{DD\pm} = \pm 2.5\text{ V}$ , $V_{IC} = 0$ , $V_O = 0$ , $R_S = 50\ \Omega$  |  | 25°C          |                                 | 0.5         | 60   | pA                           |
|                |  |   |  | 125°C         |                                 |             | 800  |                              |
| $I_{IB}$       | Input bias current   | $V_{DD\pm} = \pm 2.5\text{ V}$ , $V_{IC} = 0$ , $V_O = 0$ , $R_S = 50\ \Omega$  |  | 25°C          |                                 | 1           | 60   | pA                           |
|                |  |   |  | 125°C         |                                 |             | 800  |                              |
| $V_{ICR}$      | Common-mode input voltage range                                  | $R_S = 50\ \Omega$ , $ V_{IO}  \leq 5\text{ mV}$                                |  | 25°C          | 0 to 4                          | -0.3 to 4.2 |      | V                            |
|                |  |   |  | Full range    | 0 to 3.5                        |             |      |                              |
| $V_{OH}$       | High-level output voltage  |   |  | 25°C          |                                 | 4.99        |      | V                            |
|                |  |   |  | 25°C          | $I_{OH} = -100\ \mu\text{A}$    | 4.85        | 4.94 |                              |
|                |  |   |  | Full range    |                                 | 4.82        |      |                              |
|                |  |   |  | 25°C          | $I_{OH} = -400\ \mu\text{A}$    | 4.7         | 4.85 |                              |
| $V_{OL}$       | Low-level output voltage   | $V_{IC} = 2.5\text{ V}$   |  | 25°C          | $I_{OL} = 50\ \mu\text{A}$      | 0.01        |      | V                            |
|                |  |   |  | 25°C          | $I_{OL} = 500\ \mu\text{A}$     | 0.09        | 0.15 |                              |
|                |  |   |  | Full range    |                                 |             | 0.15 |                              |
|                |  |   |  | 25°C          | $I_{OL} = 1\text{ mA}$          | 0.2         | 0.3  |                              |
| $A_{VD}$       | Large-signal differential voltage amplification                  | $V_{IC} = 2.5\text{ V}$ , $V_O = 1\text{ V to }4\text{ V}$                      |  | 25°C          | $R_L = 50\text{ k}\Omega^{(2)}$ | 80          | 170  | V/mV                         |
|                |  |   |  | Full range    |                                 | 50          |      |                              |
|                |  |   |  | 25°C          | $R_L = 1\text{ M}\Omega^{(2)}$  |             | 550  |                              |
| $r_{i(d)}$     | Differential input resistance                                    |   |  | 25°C          |                                 | $10^{12}$   |      | $\Omega$                     |
| $r_{i(c)}$     | Common-mode input resistance                                     |   |  | 25°C          |                                 | $10^{12}$   |      | $\Omega$                     |
| $C_{i(c)}$     | Common-mode input capacitance                                    | $f = 10\text{ kHz}$   |  | 25°C          |                                 | 8           |      | pF                           |
| $Z_o$          | Closed-loop output impedance                                     | $f = 100\text{ kHz}$ , $A_V = 10$   |  | 25°C          |                                 | 240         |      | $\Omega$                     |
| CMRR           | Common-mode rejection ratio                                      | $V_{IC} = 0\text{ to }2.7\text{ V}$ , $V_O = 2.5\text{ V}$ , $R_S = 50\ \Omega$ |  | 25°C          |                                 | 70          | 83   | dB                           |
|                |  |   |  | Full range    |                                 | 70          |      |                              |
| $k_{SVR}$      | Supply voltage rejection ratio ( $\Delta V_{DD}/\Delta V_{IO}$ ) | $V_{DD} = 4.4\text{ V to }8\text{ V}$ , $V_{IC} = V_{DD}/2$ , No load           |  | 25°C          |                                 | 80          | 95   | dB                           |
|                |  |   |  | Full range    |                                 | 80          |      |                              |
| $I_{DD}$       | Supply current   | $V_O = 2.5\text{ V}$ , No load  |  | 25°C          |                                 | 0.8         | 1    | mA                           |
|                |  |   |  | Full range    |                                 |             | 1    |                              |

(1) Typical values are based on the input offset voltage shift observed through 500 hours of operating life test at  $T_A = 150^\circ\text{C}$  extrapolated to  $T_A = 25^\circ\text{C}$  using the Arrhenius equation and assuming an activation energy of 0.96 eV.

(2) Referenced to 2.5 V

**TLV2264A OPERATING CHARACTERISTICS**

V<sub>DD</sub> = 5 V, over operating free-air temperature range (unless otherwise noted)

| PARAMETER          |   | TEST CONDITIONS   | T <sub>A</sub>      | MIN  | TYP  | MAX   | UNIT   |
|--------------------|---|---|---------------------|------|------|-------|--------|
| SR                 | Slew rate at unity gain                     | V <sub>O</sub> = 0.5 V to 3.5 V, R <sub>L</sub> = 50 kΩ <sup>(1)</sup> ,<br>C <sub>L</sub> = 100 pF <sup>(1)</sup>              | 25°C                | 0.35 | 0.55 |       | V/μs   |
|                    |   |   | Full range          | 0.25 |      |       |        |
| V <sub>n</sub>     | Equivalent input noise voltage              | f = 10 Hz   | 25°C                |      | 40   |       | nV/√Hz |
|                    |   | f = 1 kHz   | 25°C                |      | 12   |       |        |
| V <sub>N(PP)</sub> | Peak-to-peak equivalent input noise voltage | f = 0.1 Hz to 1 Hz  | 25°C                |      | 0.7  |       | μV     |
|                    |   | f = 0.1 Hz to 10 Hz   | 25°C                |      | 1.3  |       |        |
| I <sub>n</sub>     | Equivalent input noise current              |   | 25°C                |      | 0.6  |       | fA/√Hz |
| THD+N              | Total harmonic distortion plus noise        | V <sub>O</sub> = 0.5 V to 2.5 V, f = 20 kHz,<br>R <sub>L</sub> = 50 kΩ <sup>(1)</sup>   | A <sub>V</sub> = 1  | 25°C |      | 0.017 | %      |
|                    |   |   | A <sub>V</sub> = 10 | 25°C |      | 0.03  |        |
|                    | Gain-bandwidth product                      | f = 50 kHz, R <sub>L</sub> = 50 kΩ <sup>(1)</sup> , C <sub>L</sub> = 100 pF <sup>(1)</sup>                                      | 25°C                |      | 0.71 |       | MHz    |
| B <sub>OM</sub>    | Maximum output-swing bandwidth              | V <sub>O(PP)</sub> = 2 V, A <sub>V</sub> = 1, R <sub>L</sub> = 50 kΩ <sup>(1)</sup> ,<br>C <sub>L</sub> = 100 pF <sup>(1)</sup> | 25°C                |      | 185  |       | kHz    |
| t <sub>s</sub>     | Settling time                               | A <sub>V</sub> = -1, Step = 0.5 V to 2.5 V,<br>R <sub>L</sub> = 50 kΩ <sup>(1)</sup> , C <sub>L</sub> = 100 pF <sup>(1)</sup>   | To 0.1%             | 25°C |      | 6.4   | μs     |
|                    |   |   | To 0.01%            | 25°C |      | 14.1  |        |
| φ <sub>m</sub>     | Phase margin at unity gain                  | R <sub>L</sub> = 50 kΩ <sup>(1)</sup> , C <sub>L</sub> = 100 pF <sup>(1)</sup>  | 25°C                |      | 56   |       | °      |
| G <sub>m</sub>     | Gain margin                                 | R <sub>L</sub> = 50 kΩ <sup>(1)</sup> , C <sub>L</sub> = 100 pF <sup>(1)</sup>  | 25°C                |      | 11   |       | dB     |

(1) Referenced to 2.5 V

## TYPICAL CHARACTERISTICS

For all curves where  $V_{DD} = 5\text{ V}$ , all loads are referenced to 2.5 V. For all curves where  $V_{DD} = 3\text{ V}$ , all loads are referenced to 1.5 V. Data at high and low temperatures are applicable only within the rated operating free-air temperature ranges of the various devices.

**Table of Graphs**

|                 |   | <b>FIGURE</b>                |            |
|-----------------|---|------------------------------|------------|
| $V_{IO}$        | Input offset voltage                            | Distribution                 | 2–5        |
|                 |   | vs Common-mode voltage       | 6, 7       |
| $\alpha_{VIO}$  | Input offset voltage temperature coefficient    | Distribution                 | 8–11       |
| $I_{IB}/I_{IO}$ | Input bias and input offset currents            | vs Free-air temperature      | 12         |
| $V_I$           | Input voltage                                   | vs Supply voltage            | 13         |
|                 |   | vs Free-air temperature      | 14         |
| $V_{OH}$        | High-level output voltage                       | vs High-level output current | 15, 18     |
| $V_{OL}$        | Low-level output voltage                        | vs Low-level output current  | 16, 17, 19 |
| $V_{O(PP)}$     | Maximum peak-to-peak output voltage             | vs Frequency                 | 20         |
| $I_{OS}$        | Short-circuit output current                    | vs Supply voltage            | 21         |
|                 |   | vs Free-air temperature      | 22         |
| $V_{ID}$        | Differential input voltage                      | vs Output voltage            | 23, 24     |
| $A_{VD}$        | Differential voltage amplification              | vs Load resistance           | 25         |
| $A_{VD}$        | Large-signal differential voltage amplification | vs Frequency                 | 26, 27     |
|                 |   | vs Free-air temperature      | 28, 29     |
| $z_o$           | Output impedance                                | vs Frequency                 | 30, 31     |
| CMRR            | Common-mode rejection ratio                     | vs Frequency                 | 32         |
|                 |   | vs Free-air temperature      | 33         |
| $k_{SVR}$       | Supply-voltage rejection ratio                  | vs Frequency                 | 34, 35     |
|                 |   | vs Free-air temperature      | 36, 37     |
| $I_{DD}$        | Supply current                                  | vs Free-air temperature      | 38, 39     |
| SR              | Slew rate                                       | vs Load capacitance          | 40         |
|                 |   | vs Free-air temperature      | 41         |
| $V_O$           | Inverting large-signal pulse response           |                              | 42, 43     |
| $V_O$           | Voltage-follower large-signal pulse response    |                              | 44, 45     |
| $V_O$           | Inverting small-signal pulse response           |                              | 46, 47     |
| $V_O$           | Voltage-follower small-signal pulse response    |                              | 48, 49     |
| $V_n$           | Equivalent input noise voltage                  | vs Frequency                 | 50, 51     |
|                 | Input noise voltage                             | Over a 10-second period      | 52         |
|                 | Integrated noise voltage                        | vs Frequency                 | 53         |
| THD+N           | Total harmonic distortion plus noise            | vs Frequency                 | 54         |
|                 | Gain-bandwidth product                          | vs Supply voltage            | 55         |
|                 |   | vs Free-air temperature      | 56         |
|                 |   | vs Frequency                 | 26, 27     |
| $\phi_m$        | Phase margin                                    | vs Load capacitance          | 57         |
| $G_m$           | Gain margin                                     | vs Load capacitance          | 58         |
| $B_1$           | Unity-gain bandwidth                            | vs Load capacitance          | 59         |
|                 | Overestimation of phase margin                  | vs Load capacitance          | 60         |

**DISTRIBUTION OF TLV2262  
INPUT OFFSET VOLTAGE**

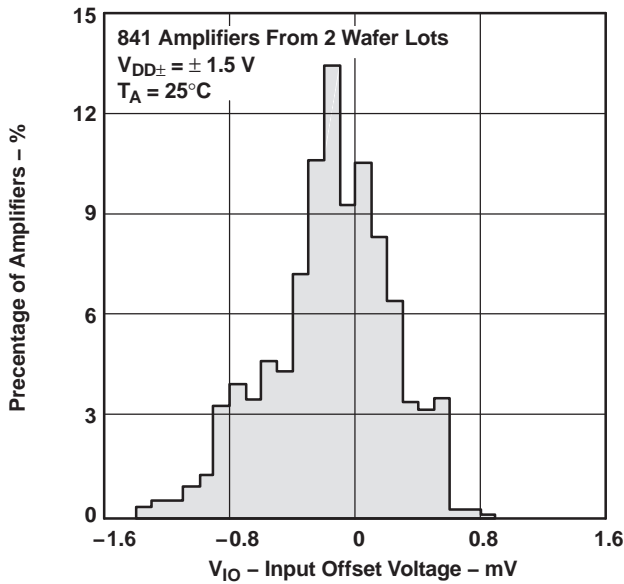

Figure 2.

**DISTRIBUTION OF TLV2262  
INPUT OFFSET VOLTAGE**

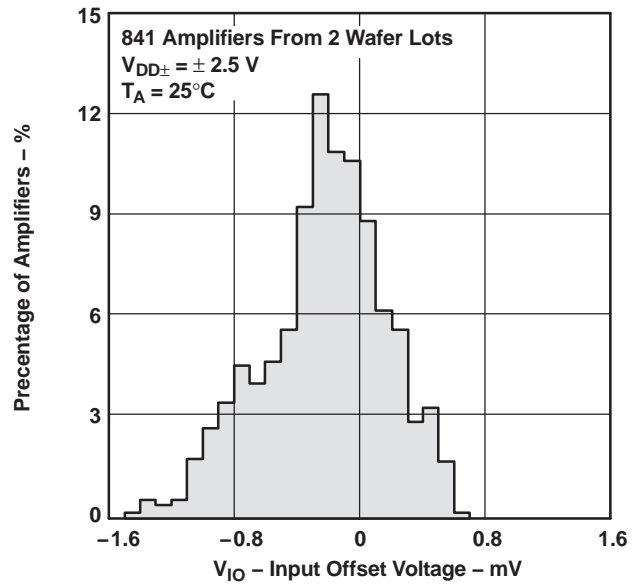

Figure 3.

**DISTRIBUTION OF TLV2264  
INPUT OFFSET VOLTAGE**

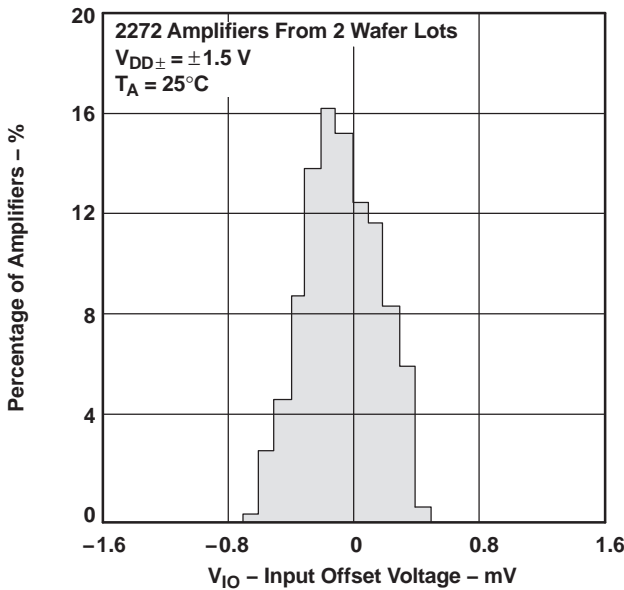

Figure 4.

**DISTRIBUTION OF TLV2264  
INPUT OFFSET VOLTAGE**

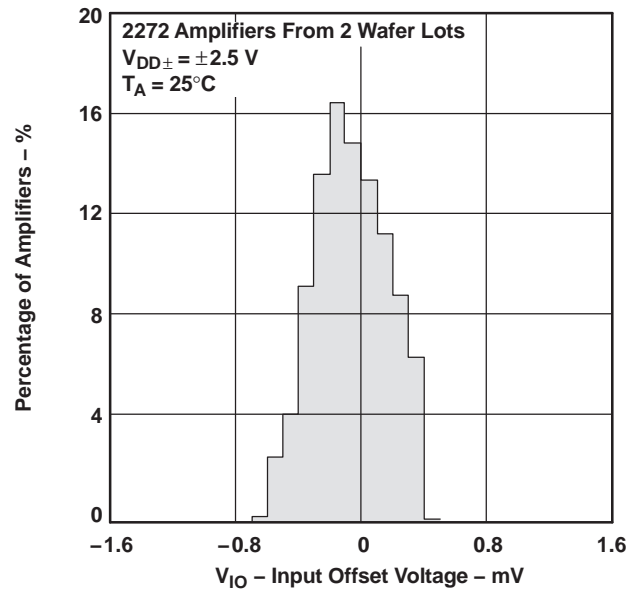

Figure 5.

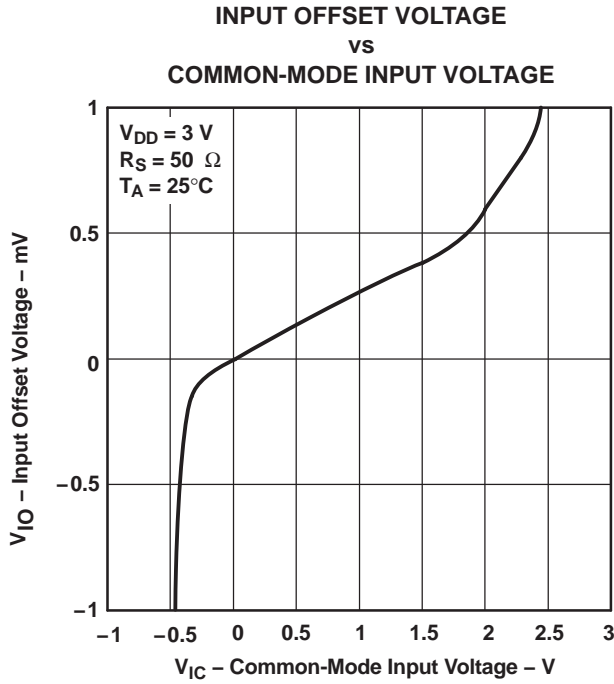

Figure 6.

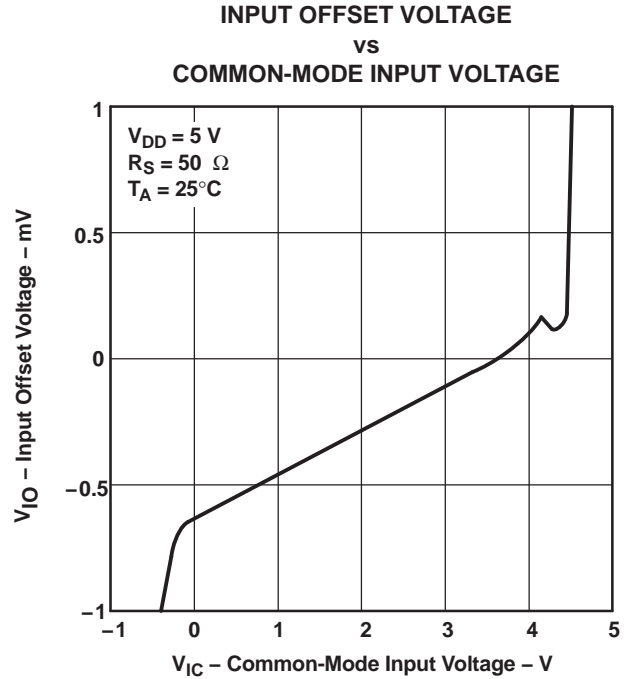

Figure 7.

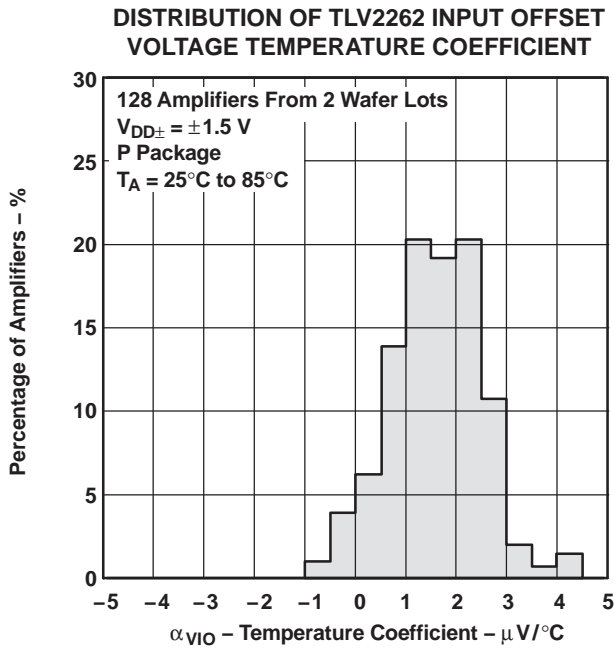

Figure 8.

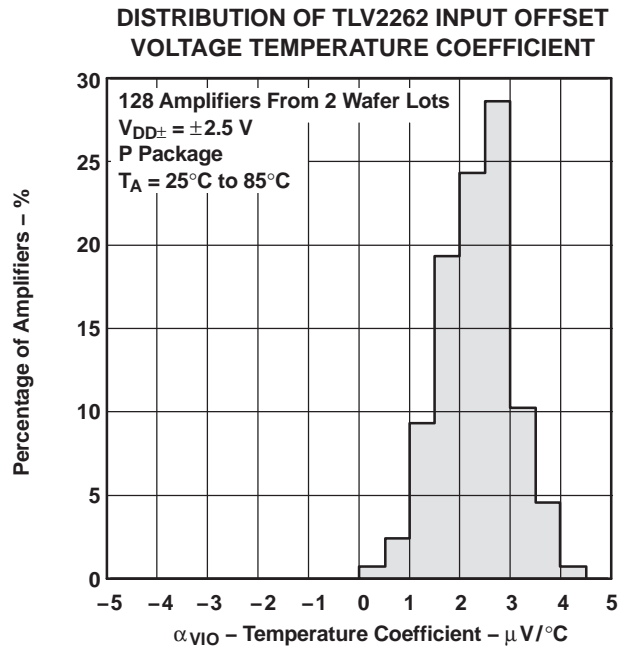

Figure 9.

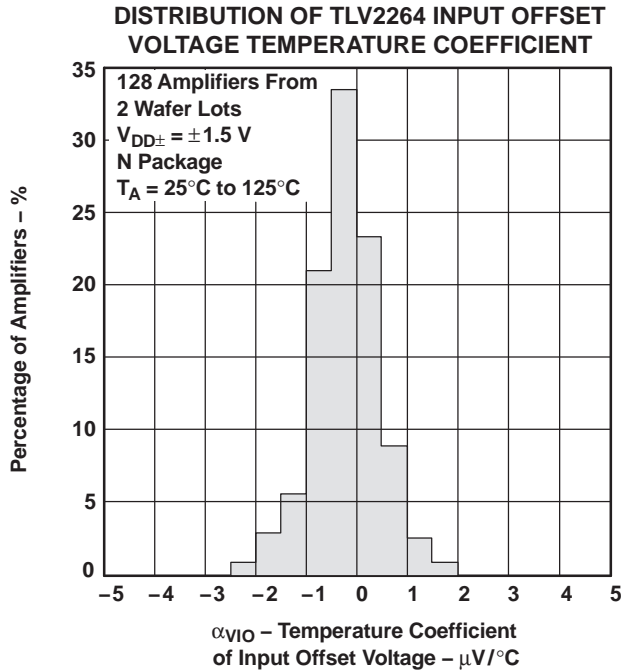

Figure 10.

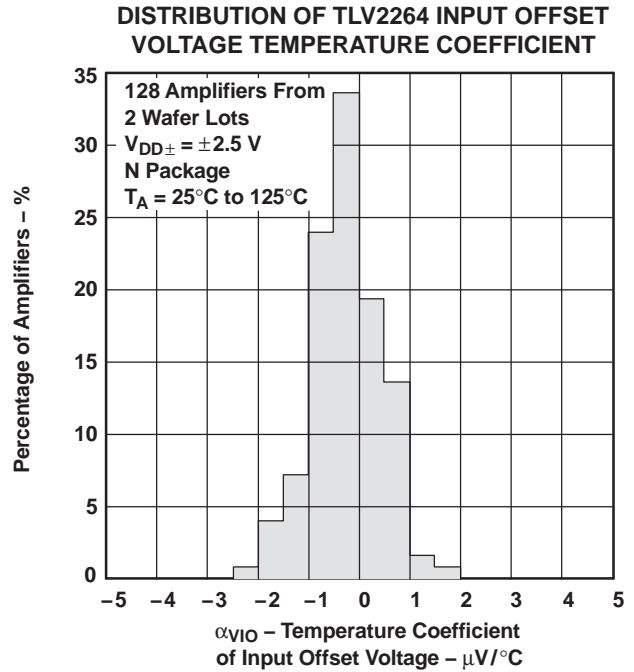

Figure 11.

**INPUT BIAS AND INPUT OFFSET CURRENTS  
vs  
FREE-AIR TEMPERATURE**

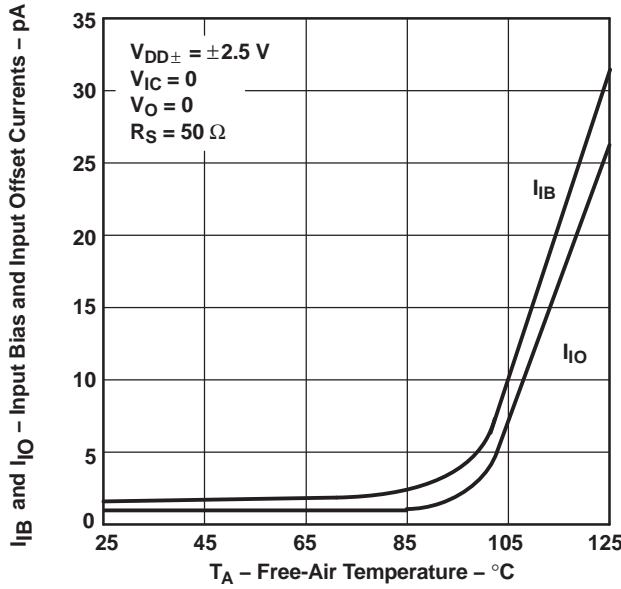

Figure 12.

**INPUT VOLTAGE  
vs  
SUPPLY VOLTAGE**

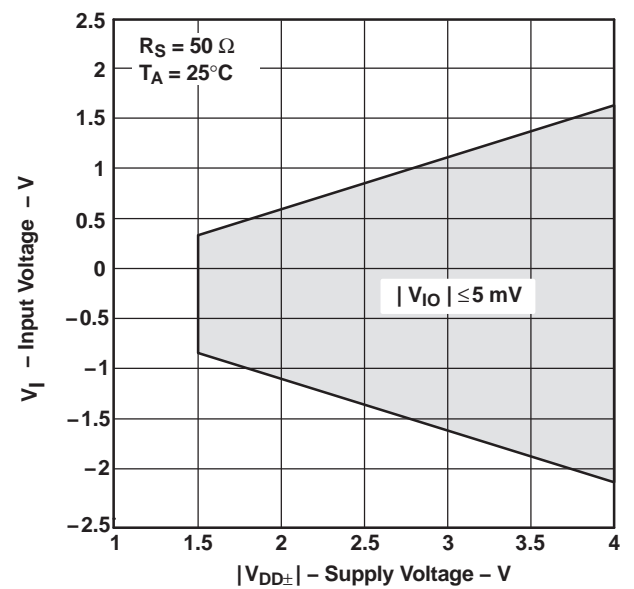

Figure 13.

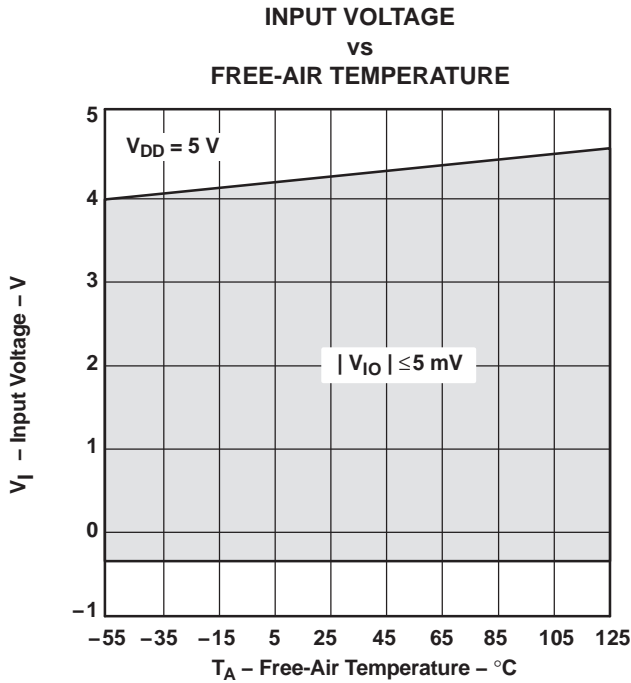

Figure 14.

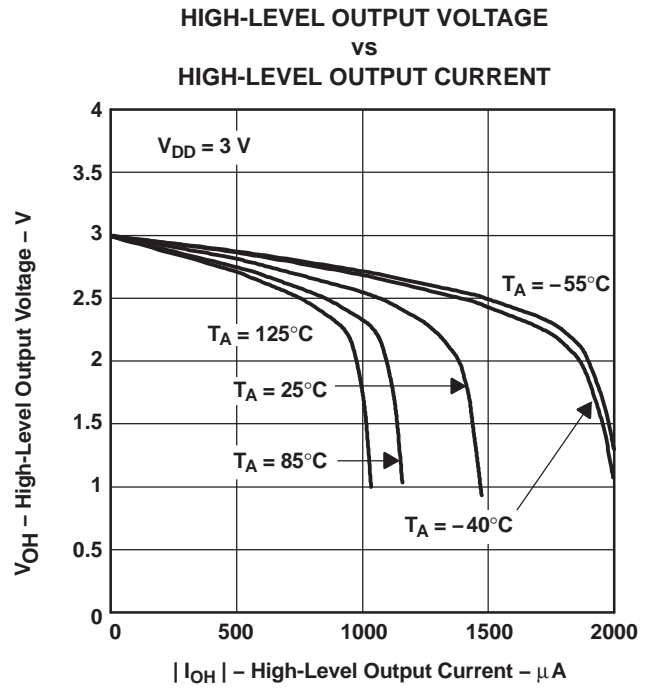

Figure 15.

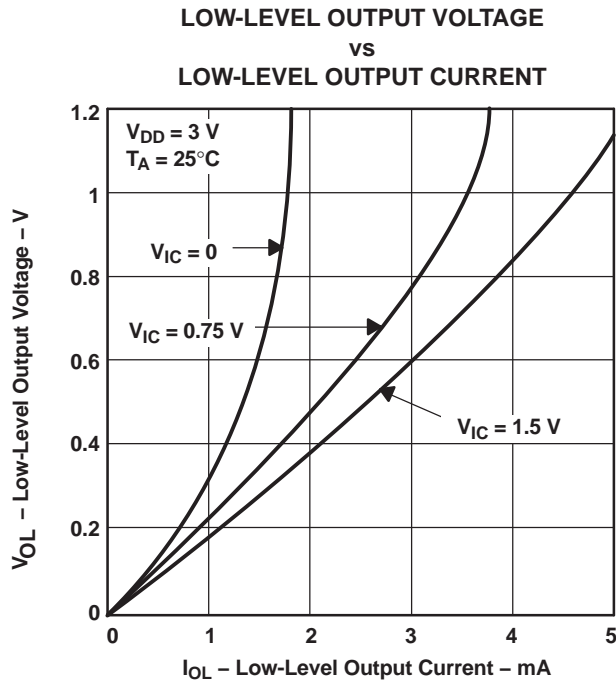

Figure 16.

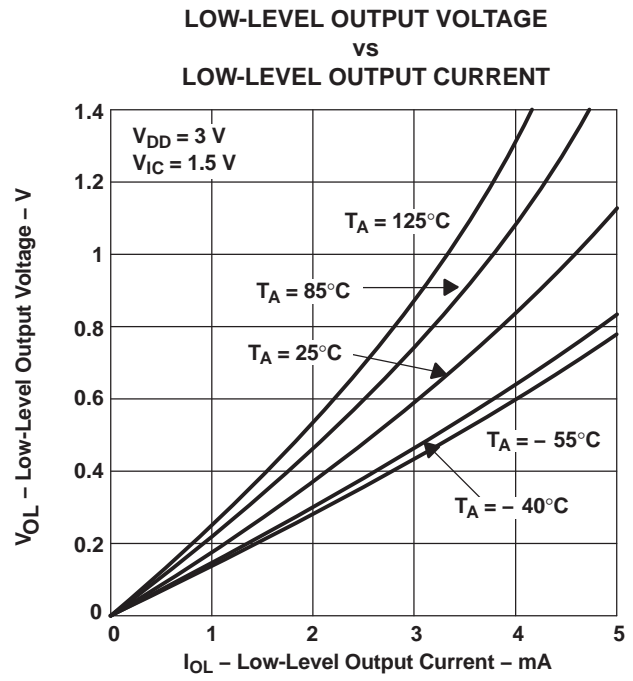
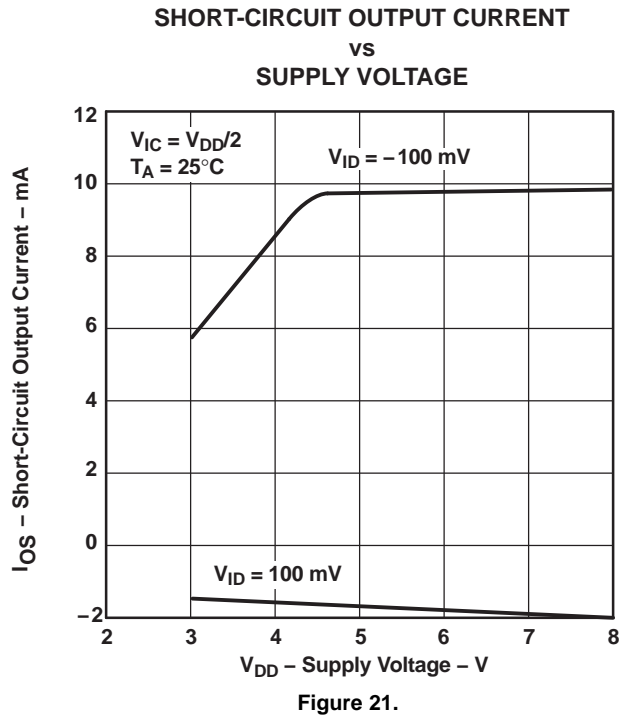
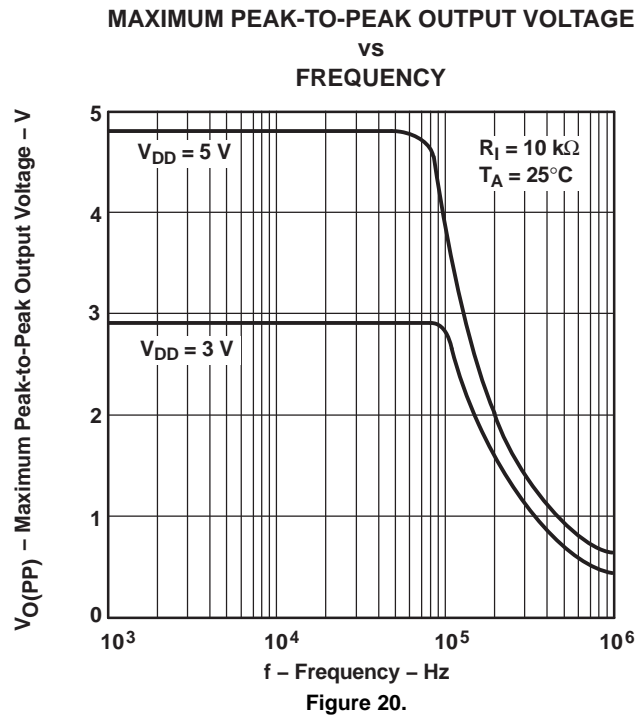
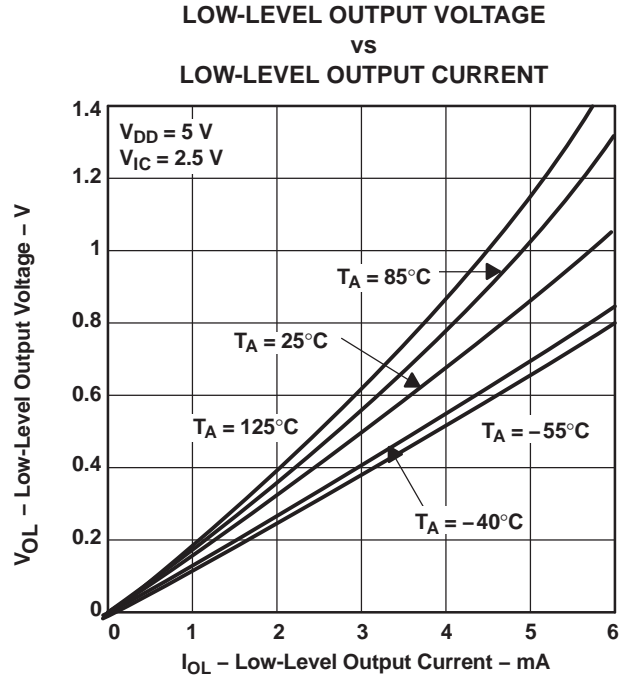
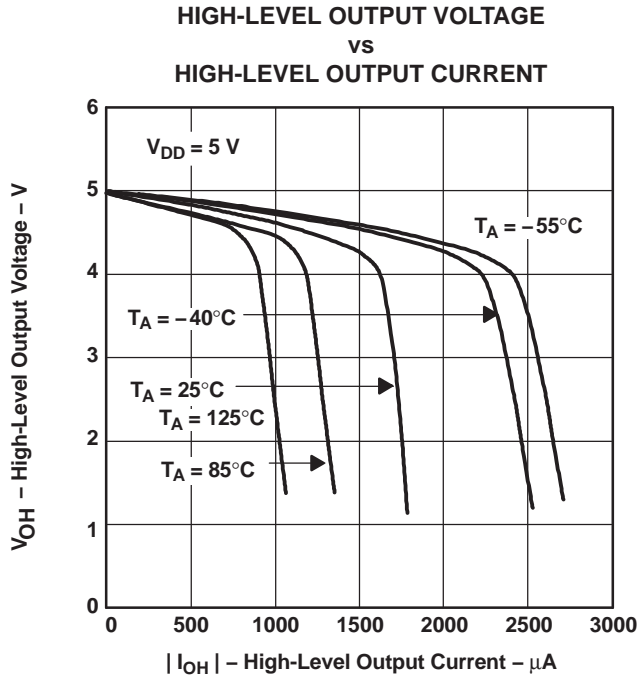

Figure 17.



SHORT-CIRCUIT OUTPUT CURRENT  
vs  
FREE-AIR TEMPERATURE

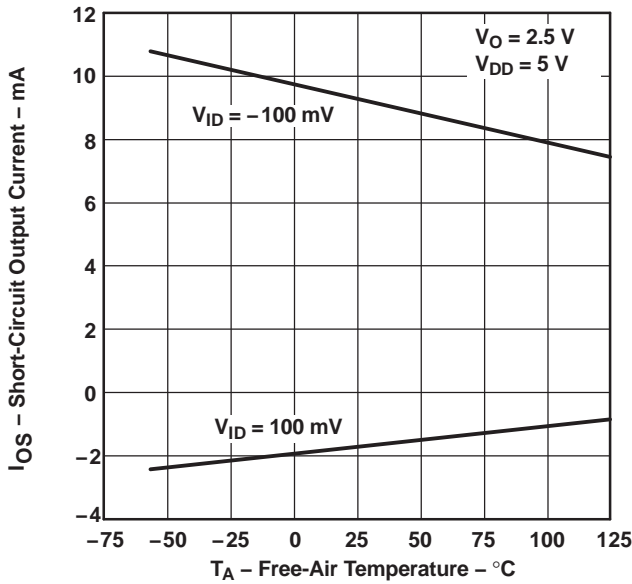

Figure 22.

DIFFERENTIAL INPUT VOLTAGE  
vs  
OUTPUT VOLTAGE

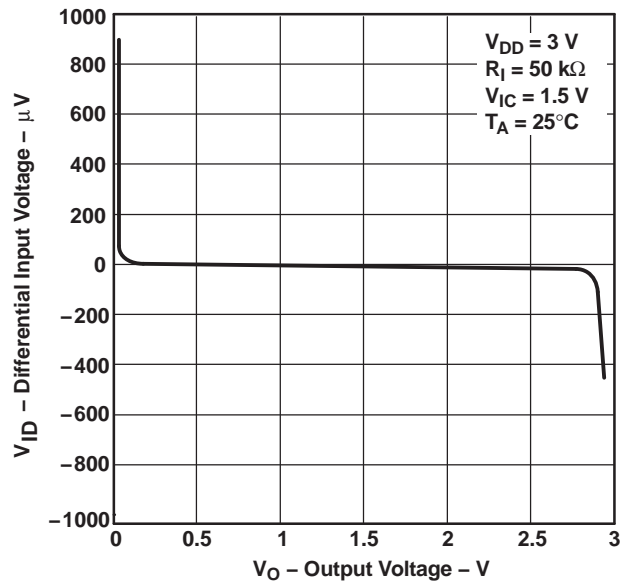

Figure 23.

DIFFERENTIAL INPUT VOLTAGE  
vs  
OUTPUT VOLTAGE

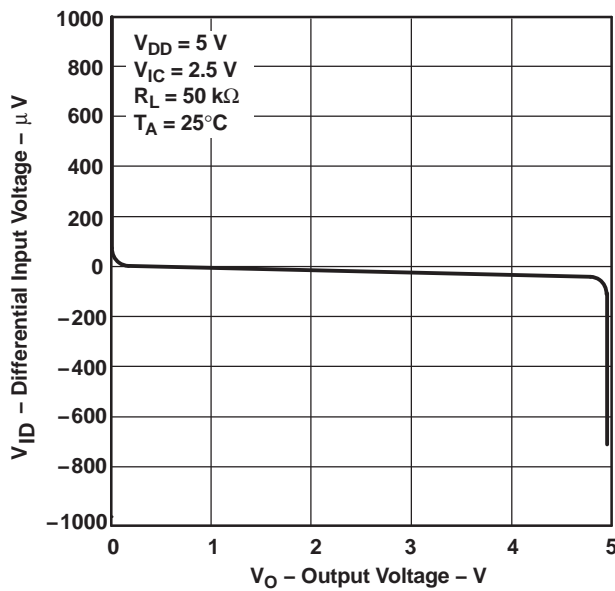

Figure 24.

DIFFERENTIAL VOLTAGE AMPLIFICATION  
vs  
LOAD RESISTANCE

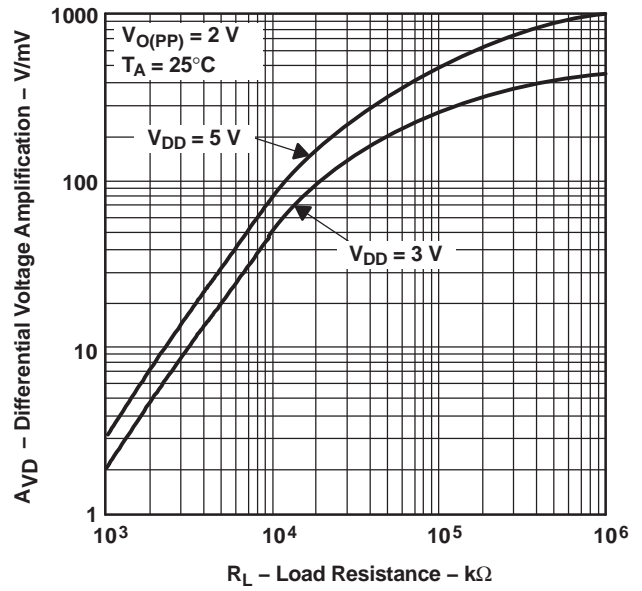

Figure 25.

LARGE-SIGNAL DIFFERENTIAL VOLTAGE AMPLIFICATION AND PHASE MARGIN VS FREQUENCY

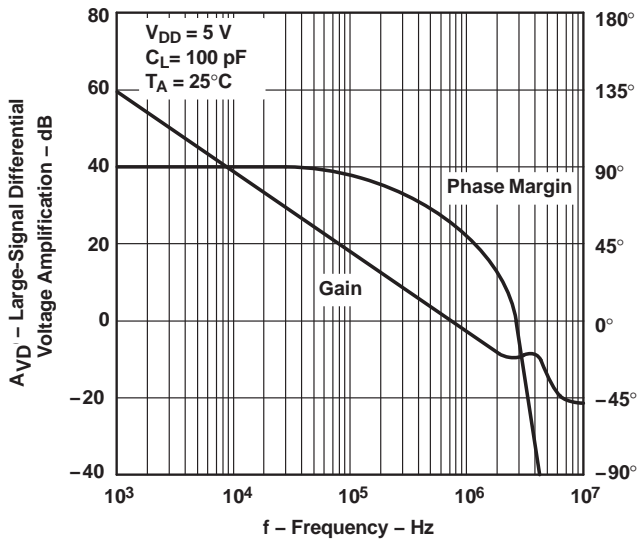

Figure 26.

LARGE-SIGNAL DIFFERENTIAL VOLTAGE AMPLIFICATION AND PHASE MARGIN VS FREQUENCY

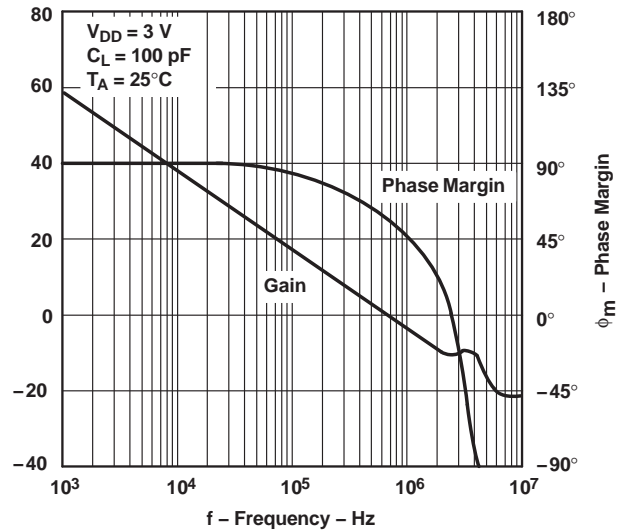

Figure 27.

LARGE-SIGNAL DIFFERENTIAL VOLTAGE AMPLIFICATION VS FREE-AIR TEMPERATURE

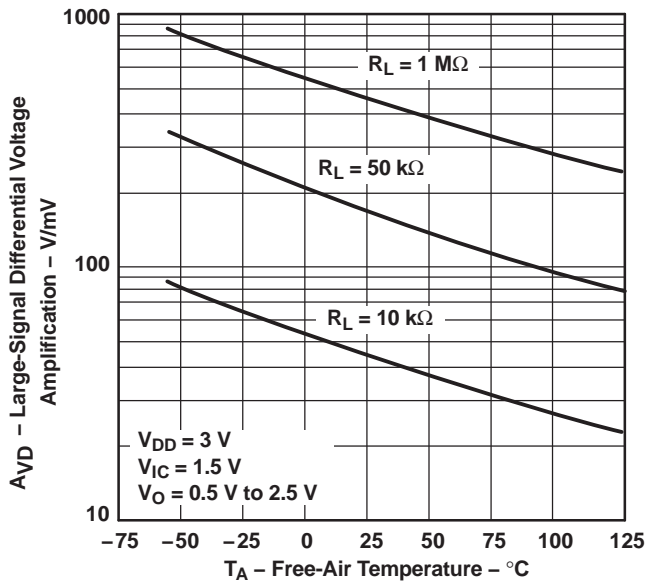

Figure 28.

LARGE-SIGNAL DIFFERENTIAL VOLTAGE AMPLIFICATION VS FREE-AIR TEMPERATURE

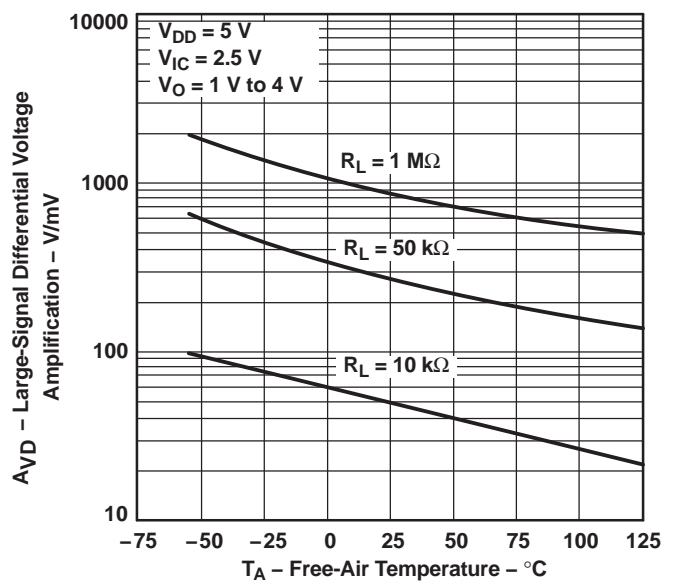

Figure 29.

OUTPUT IMPEDANCE  
VS  
FREQUENCY

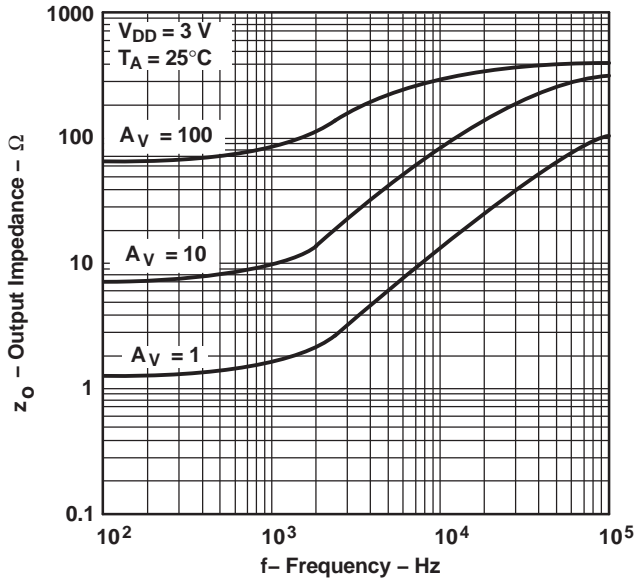

Figure 30.

OUTPUT IMPEDANCE  
VS  
FREQUENCY

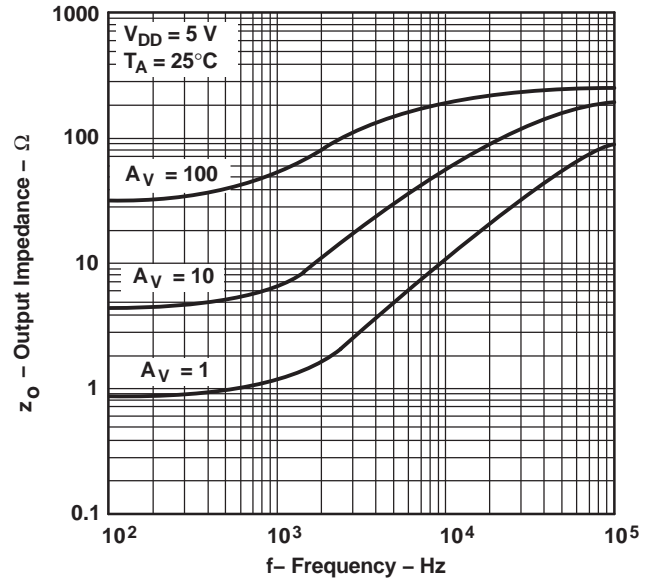

Figure 31.

COMMON-MODE REJECTION RATIO  
VS  
FREQUENCY

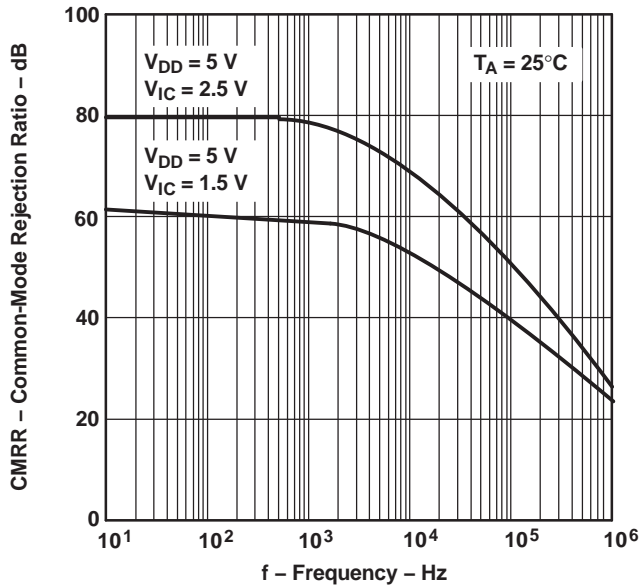

Figure 32.

COMMON-MODE REJECTION RATIO  
VS  
FREE-AIR TEMPERATURE

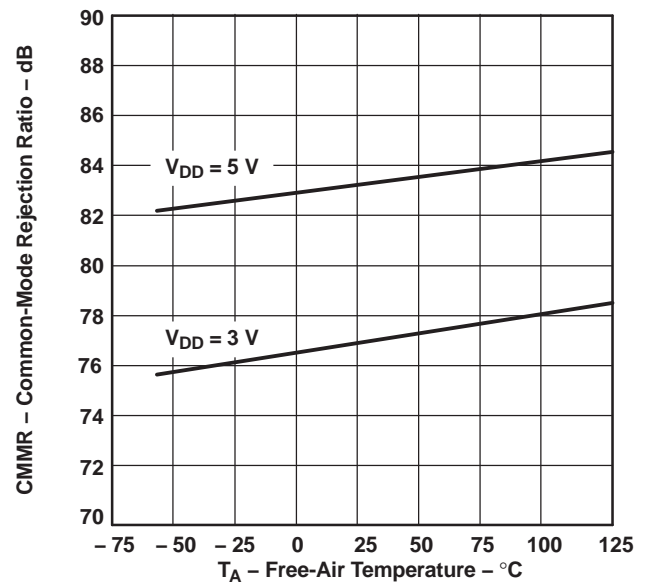

Figure 33.

SUPPLY-VOLTAGE REJECTION RATIO  
VS  
FREQUENCY

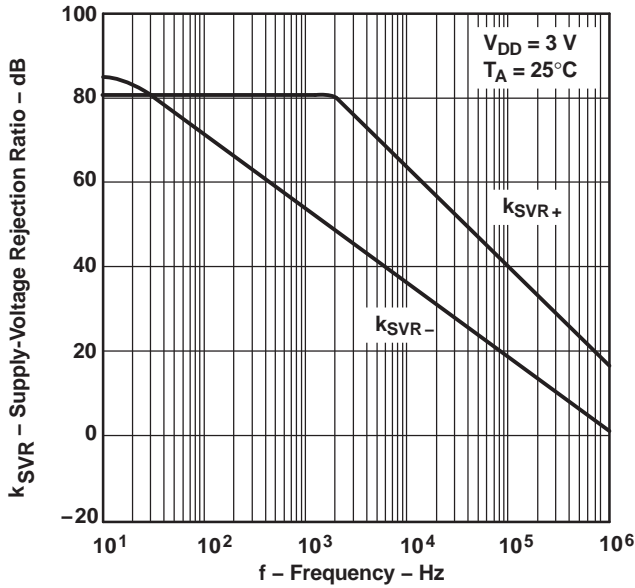

Figure 34.

TLV2262

SUPPLY-VOLTAGE REJECTION RATIO  
VS  
FREE-AIR TEMPERATURE

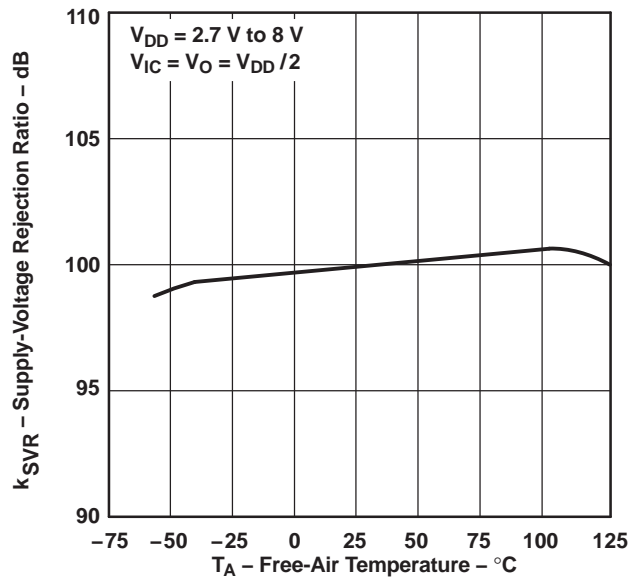

Figure 36.

SUPPLY-VOLTAGE REJECTION RATIO  
VS  
FREQUENCY

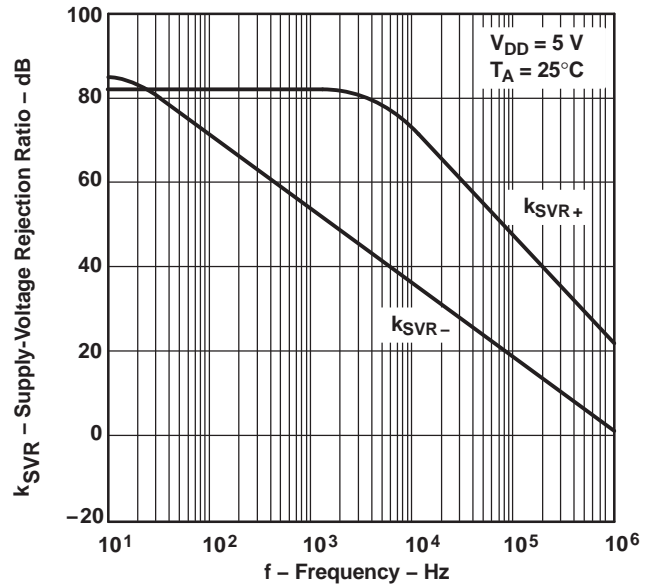

Figure 35.

TLV2264

SUPPLY-VOLTAGE REJECTION RATIO  
VS  
FREE-AIR TEMPERATURE

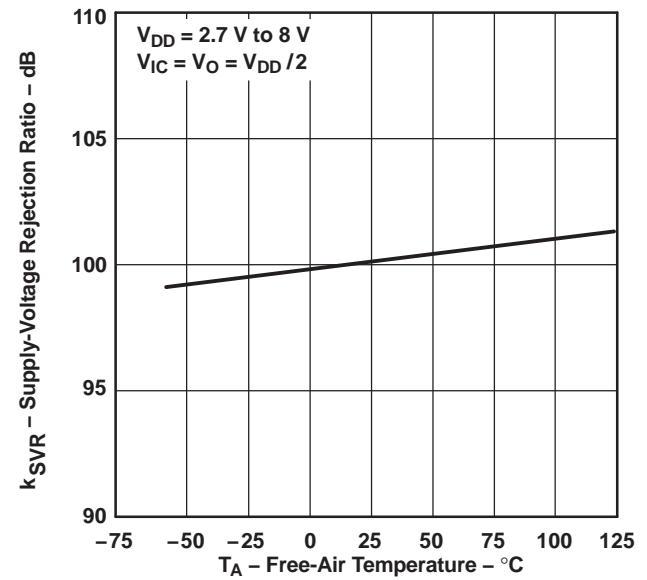

Figure 37.

TLV2262  
SUPPLY CURRENT  
vs  
FREE-AIR TEMPERATURE

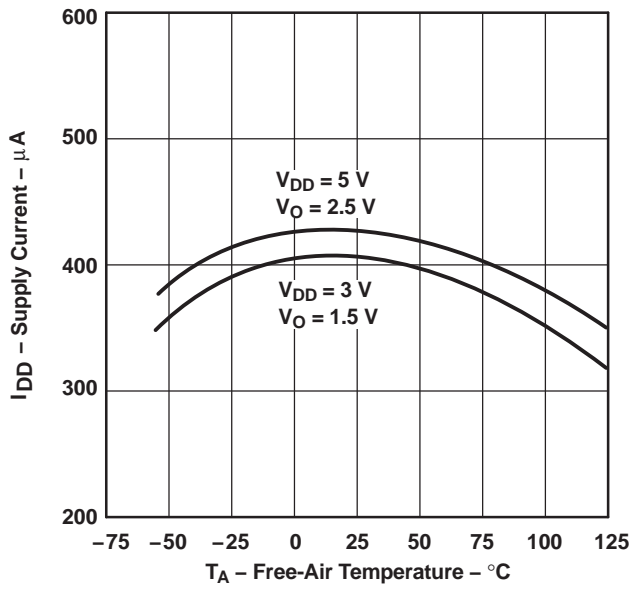

Figure 38.

TLV2264  
SUPPLY CURRENT  
vs  
FREE-AIR TEMPERATURE

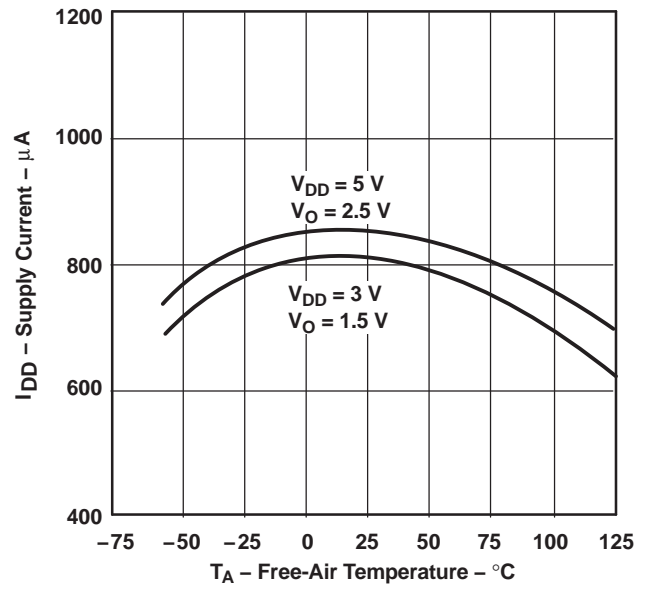

Figure 39.

SLEW RATE  
vs  
LOAD CAPACITANCE

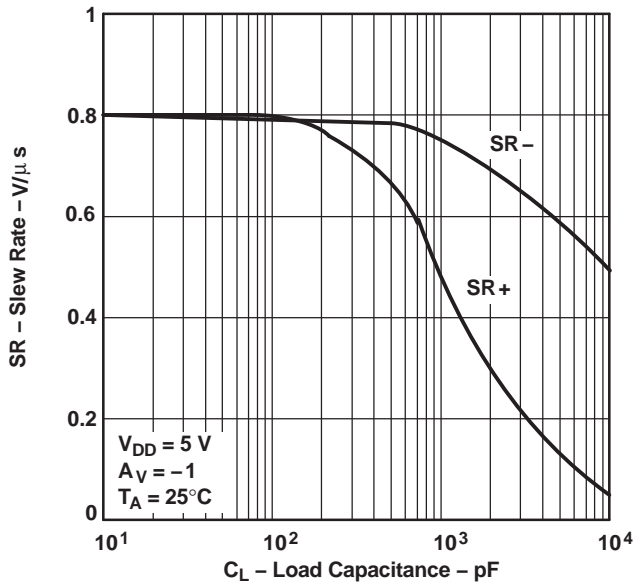

Figure 40.

SLEW RATE  
vs  
FREE-AIR TEMPERATURE

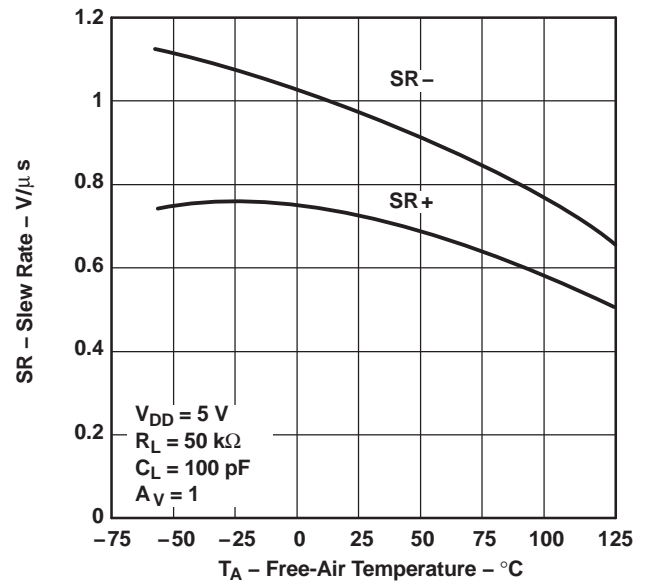

Figure 41.

**INVERTING LARGE-SIGNAL PULSE RESPONSE**

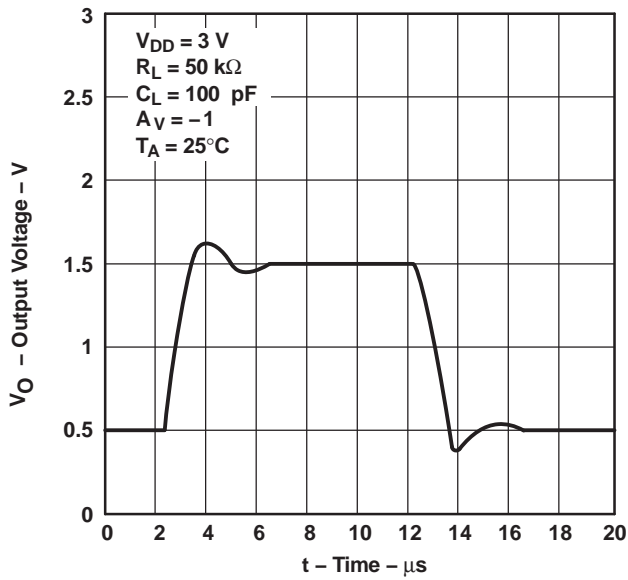

Figure 42.

**INVERTING LARGE-SIGNAL PULSE RESPONSE**

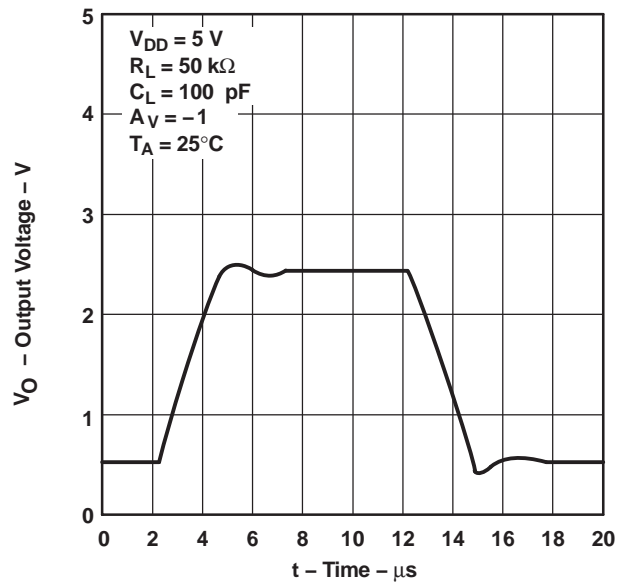

Figure 43.

**VOLTAGE-FOLLOWER LARGE-SIGNAL PULSE RESPONSE**

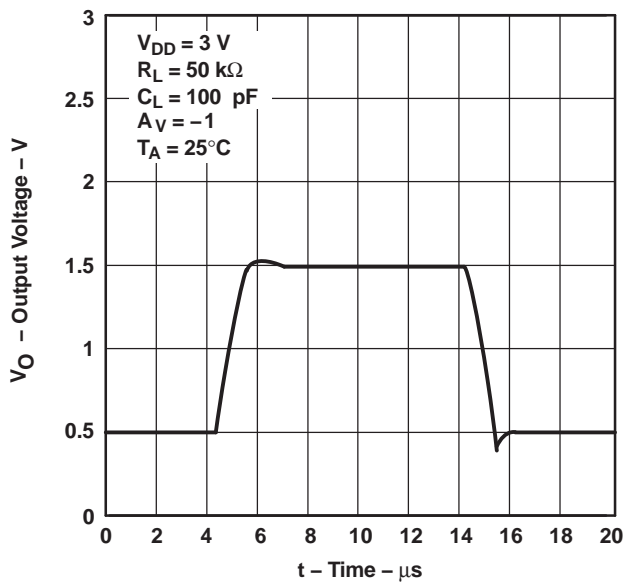

Figure 44.

**VOLTAGE-FOLLOWER LARGE-SIGNAL PULSE RESPONSE**

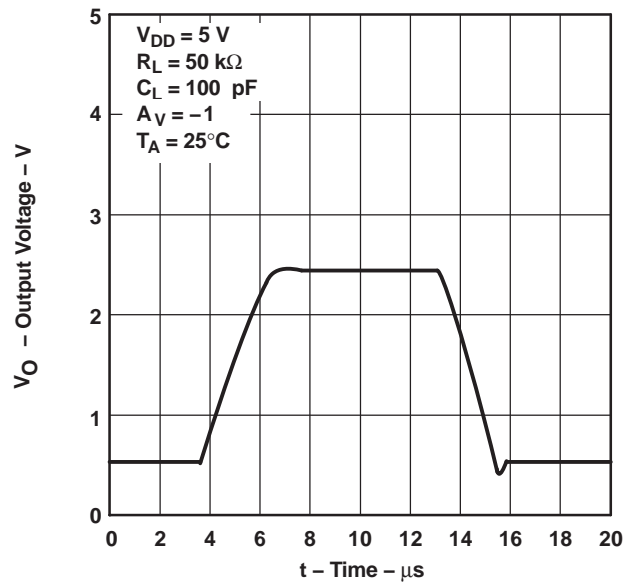

Figure 45.

INVERTING SMALL-SIGNAL PULSE RESPONSE

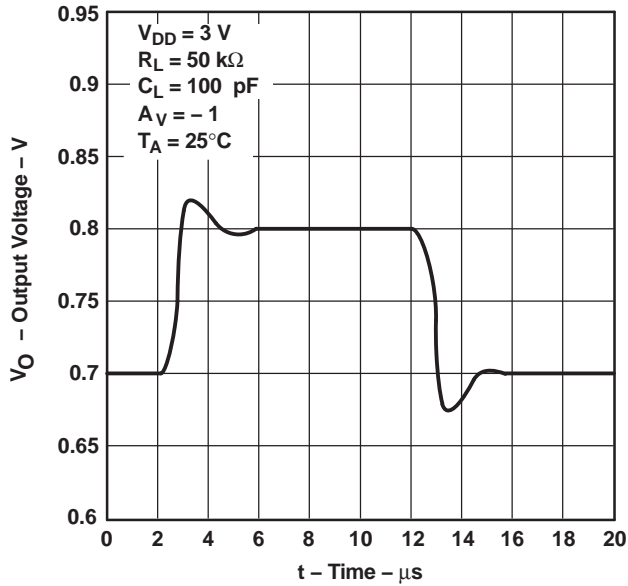

Figure 46.

INVERTING SMALL-SIGNAL PULSE RESPONSE

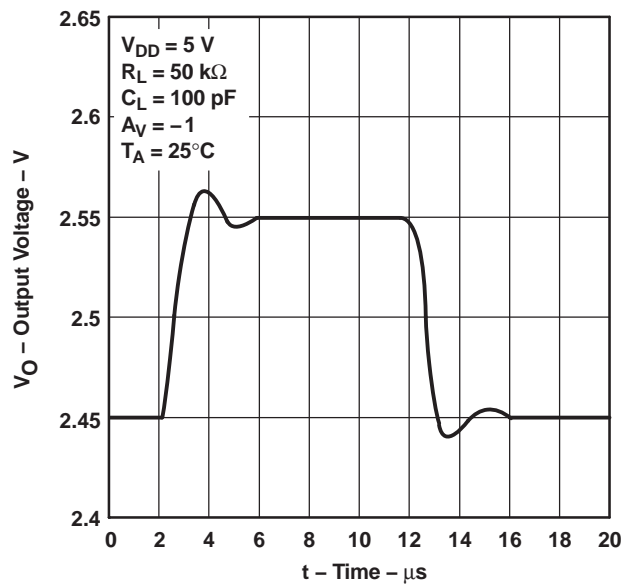

Figure 47.

VOLTAGE-FOLLOWER SMALL-SIGNAL PULSE RESPONSE

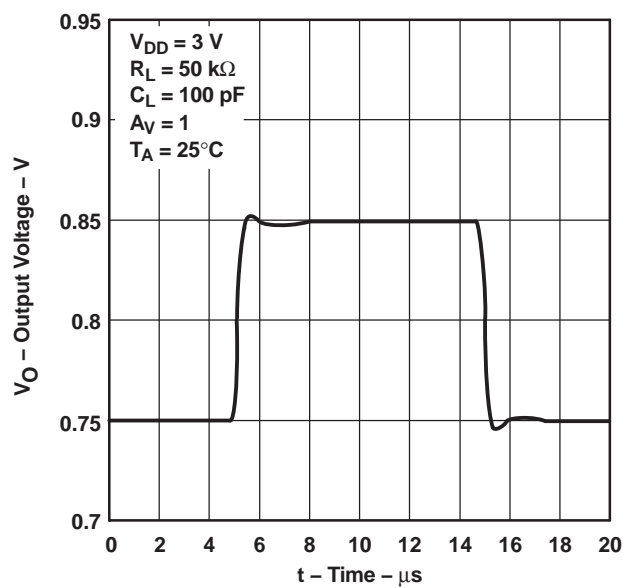

Figure 48.

VOLTAGE-FOLLOWER SMALL-SIGNAL PULSE RESPONSE

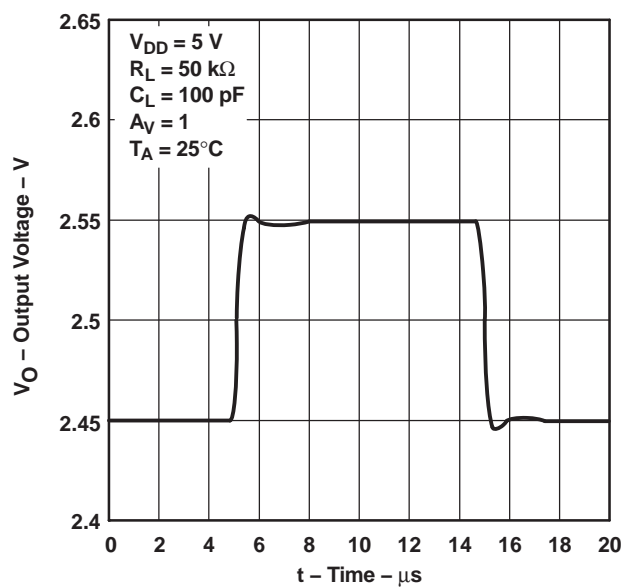

Figure 49.

**EQUIVALENT INPUT NOISE VOLTAGE  
VS  
FREQUENCY**

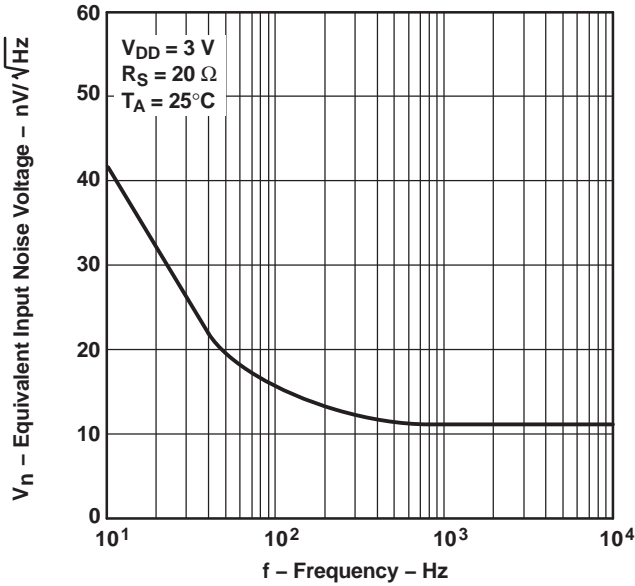

Figure 50.

**EQUIVALENT INPUT NOISE VOLTAGE  
VS  
FREQUENCY**

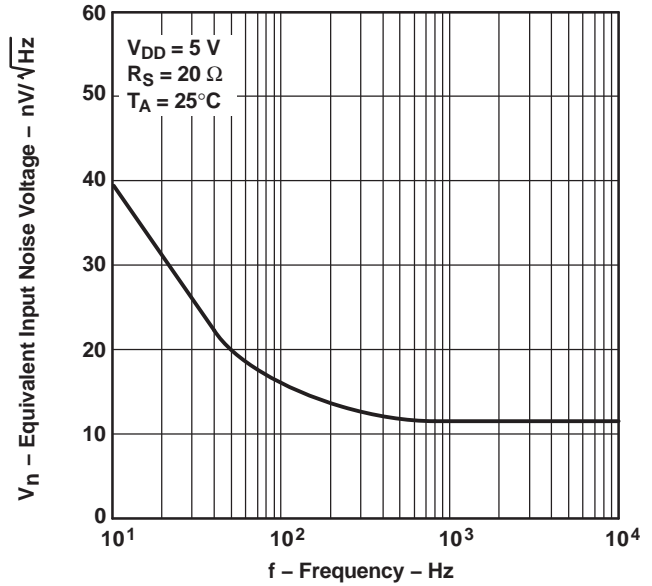

Figure 51.

**INPUT NOISE VOLTAGE OVER  
A 10-SECOND PERIOD**

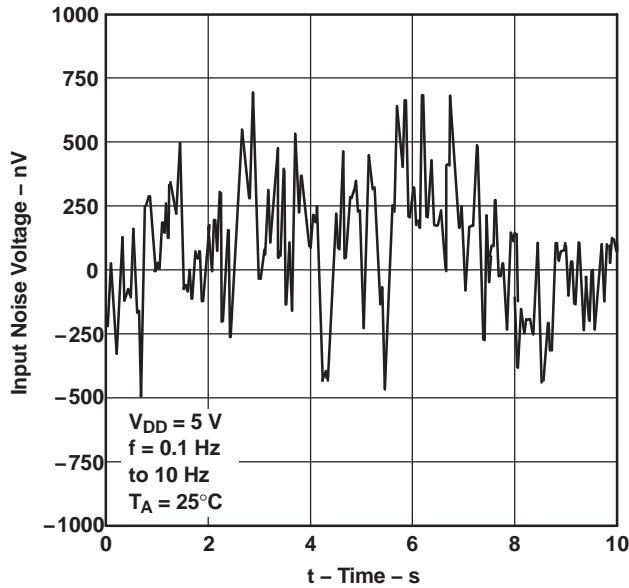

Figure 52.

**INTEGRATED NOISE VOLTAGE  
VS  
FREQUENCY**

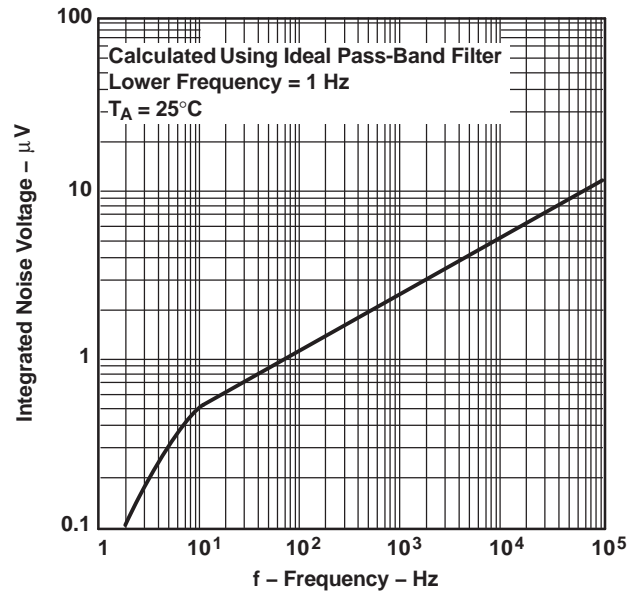

Figure 53.

TOTAL HARMONIC DISTORTION PLUS NOISE  
VS  
FREQUENCY

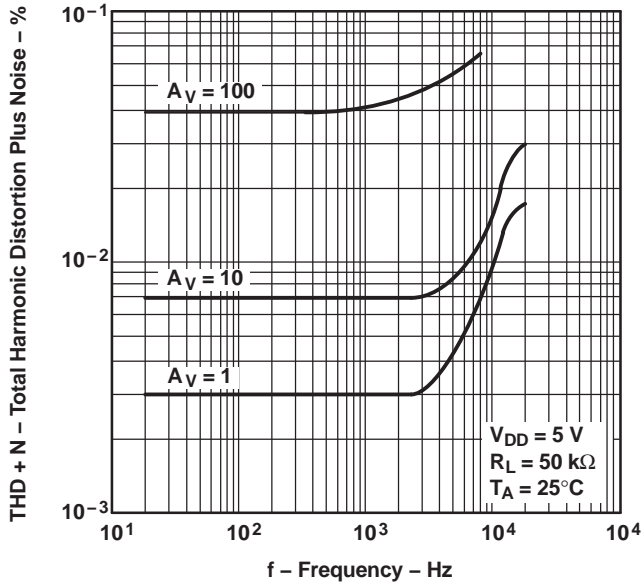

Figure 54.  
GAIN-BANDWIDTH PRODUCT  
VS  
FREE-AIR TEMPERATURE

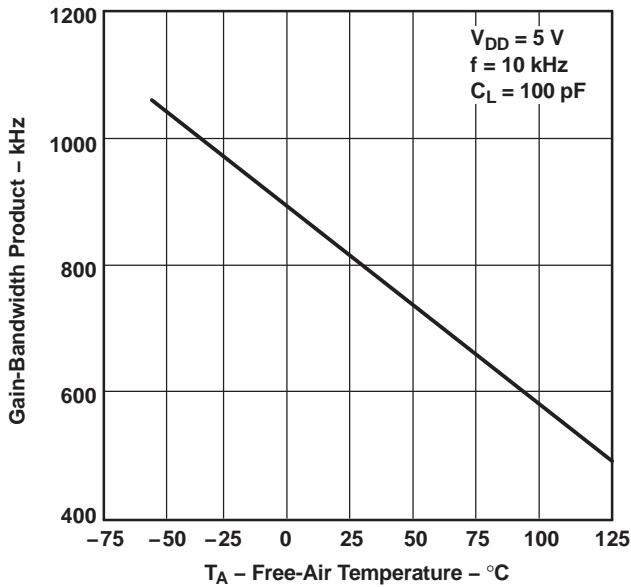

Figure 56.

GAIN-BANDWIDTH PRODUCT  
VS  
SUPPLY VOLTAGE

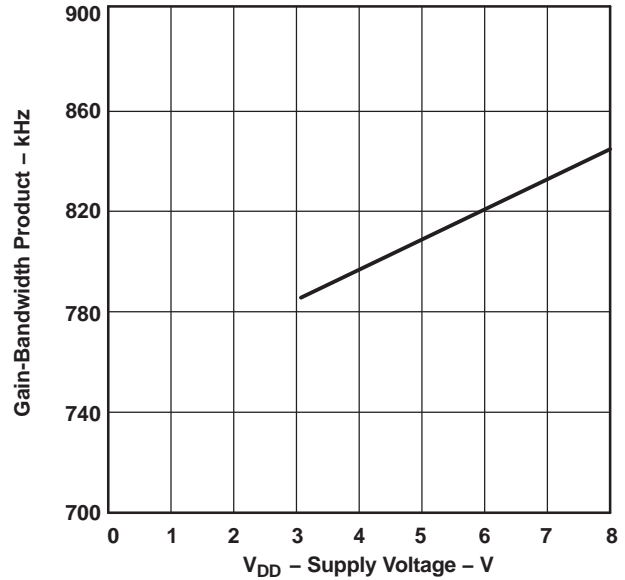

Figure 55.

PHASE MARGIN  
VS  
LOAD CAPACITANCE

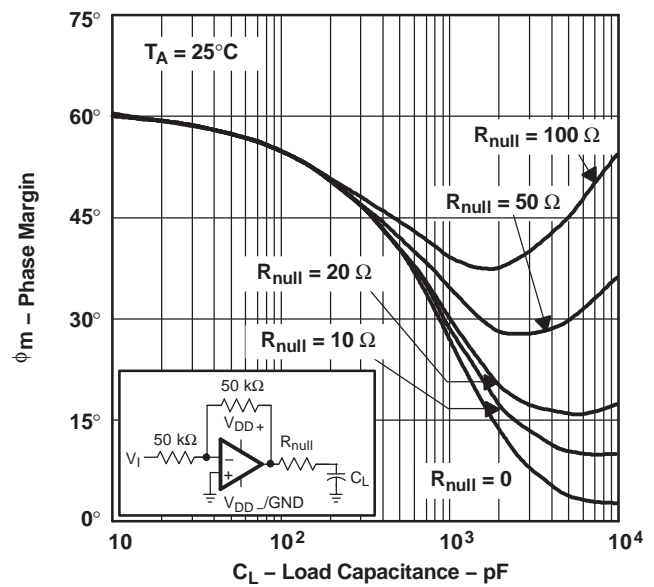

Figure 57.

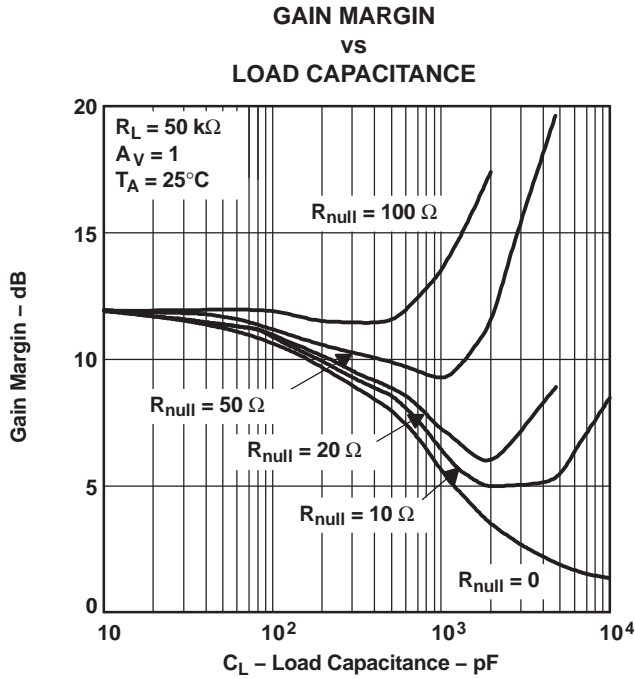

Figure 58.

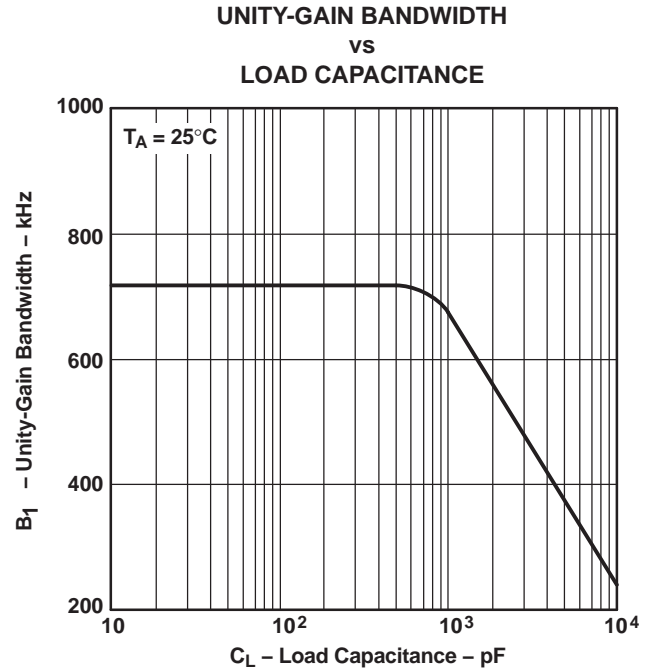
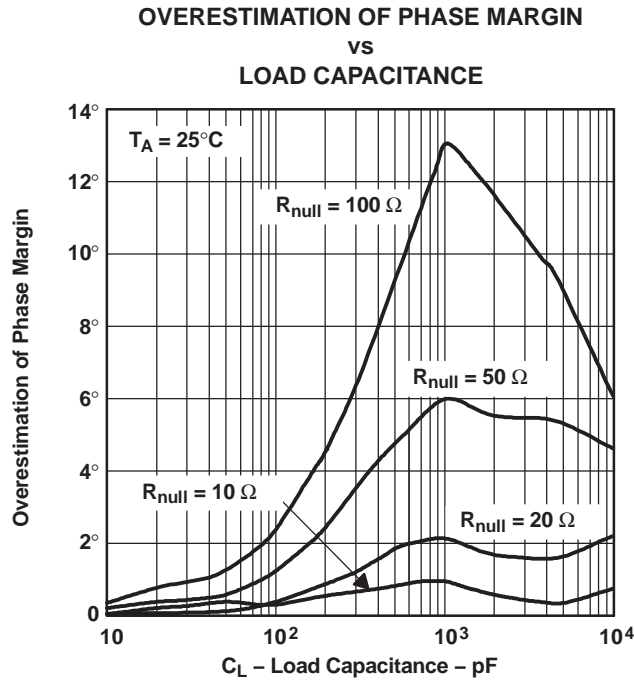

Figure 59.



NOTE: See application information.  
 Figure 60.

## APPLICATION INFORMATION

### Driving Large Capacitive Loads

The TLV226x is designed to drive larger capacitive loads than most CMOS operational amplifiers. Figure 51 and Figure 52 illustrate its ability to drive loads greater than 400 pF while maintaining good gain and phase margins ( $R_{null} = 0$ ).

A smaller series resistor ( $R_{null}$ ) at the output of the device (see Figure 61) improves the gain and phase margins when driving large capacitive loads. Figure 51 and Figure 52 show the effects of adding series resistances of 10  $\Omega$ , 20  $\Omega$ , 50  $\Omega$ , and 100  $\Omega$ . The addition of this series resistor has two effects: the first is that it adds a zero to the transfer function and the second is that it reduces the frequency of the pole associated with the output load in the transfer function.

The zero introduced to the transfer function is equal to the series resistance times the load capacitance. To calculate the improvement in phase margin, Equation 1 can be used.

$$\Delta\theta_{m1} = \tan^{-1} \left( 2 \times \pi \times \text{UGBW} \times R_{null} \times C_L \right)$$

Where :

$\Delta\theta_{m1}$  = improvement in phase margin

UGBW = unity-gain bandwidth frequency

$R_{null}$  = output series resistance

$C_L$  = load capacitance

(1)

The unity-gain bandwidth (UGBW) frequency decreases as the capacitive load increases (see Figure 53). To use Equation 1, UGBW must be approximated from Figure 53.

Using Equation 1 alone overestimates the improvement in phase margin as illustrated in Figure 60. The overestimation is caused by the decrease in the frequency of the pole associated with the load, providing additional phase shift and reducing the overall improvement in phase margin. The pole associated with the load is reduced by the factor calculated in Equation 2.

$$F = \frac{1}{1 + g_m \times R_{null}}$$

Where :

F = factor reducing frequency of pole

$g_m$  = small-signal output transconductance (typically  $4.83 \times 10^{-3}$  mhos)

$R_{null}$  = output series resistance

(2)

For the TLV226x, the pole associated with the load is typically 7 MHz with 100-pF load capacitance. This value varies inversely with  $C_L$ : at  $C_L = 10$  pF, use 70 MHz, at  $C_L = 1000$  pF, use 700 kHz, and so on.

Reducing the pole associated with the load introduces phase shift, thereby reducing phase margin. This results in an error in the increase in phase margin expected by considering the zero alone (see Equation 1). Equation 3 approximates the reduction in phase margin due to the movement of the pole associated with the load. The result of this equation can be subtracted from the result of the Equation 1 to better approximate the improvement in phase margin.

$$\Delta\theta_{m2} = \tan^{-1} \left[ \frac{\text{UGBW}}{(F \times P_2)} \right] - \tan^{-1} \left( \frac{\text{UGBW}}{P_2} \right)$$

Where :

$\Delta\theta_{m2}$  = reduction in phase margin

UGBW = unity-gain bandwidth frequency

F = factor from equation (2)

$P_2$  = unadjusted pole (70 MHz @ 10 pF, 7 MHz @ 100 pF, etc.)

(3)

Using these equations with Figure 60 and Figure 61 enables the designer to choose the appropriate output series resistance to optimize the design of circuits driving large capacitive loads.

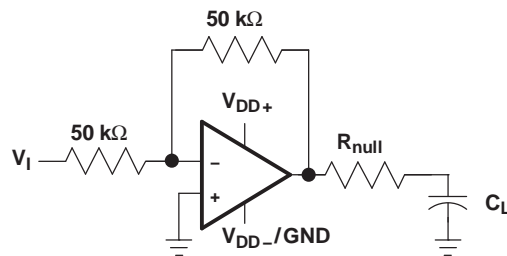

**Figure 61. Series-Resistance Circuit**

### Macromodel Information

Macromodel information provided was derived using Microsim Parts™, the model generation software used with Microsim PSpice™. The Boyle macromodel<sup>(1)</sup> and subcircuit in Figure 62 are generated using the TLV226x typical electrical and operating characteristics at  $T_A = 25^\circ\text{C}$ . Using this information, output simulations of the following key parameters can be generated to a tolerance of 20% (in most cases):

- Maximum positive output voltage swing
- Maximum negative output voltage swing
- Slew rate
- Quiescent power dissipation
- Input bias current
- Open-loop voltage amplification
- Unity-gain frequency
- Common-mode rejection ratio
- Phase margin
- DC output resistance
- AC output resistance
- Short-circuit output current limit

(1) G. R. Boyle, B. M. Cohn, D. O. Pederson, and J. E. Solomon, "Macromodeling of Integrated Circuit Operational Amplifiers," *IEEE Journal of Solid-State Circuits*, SC-9, 353 (1974).

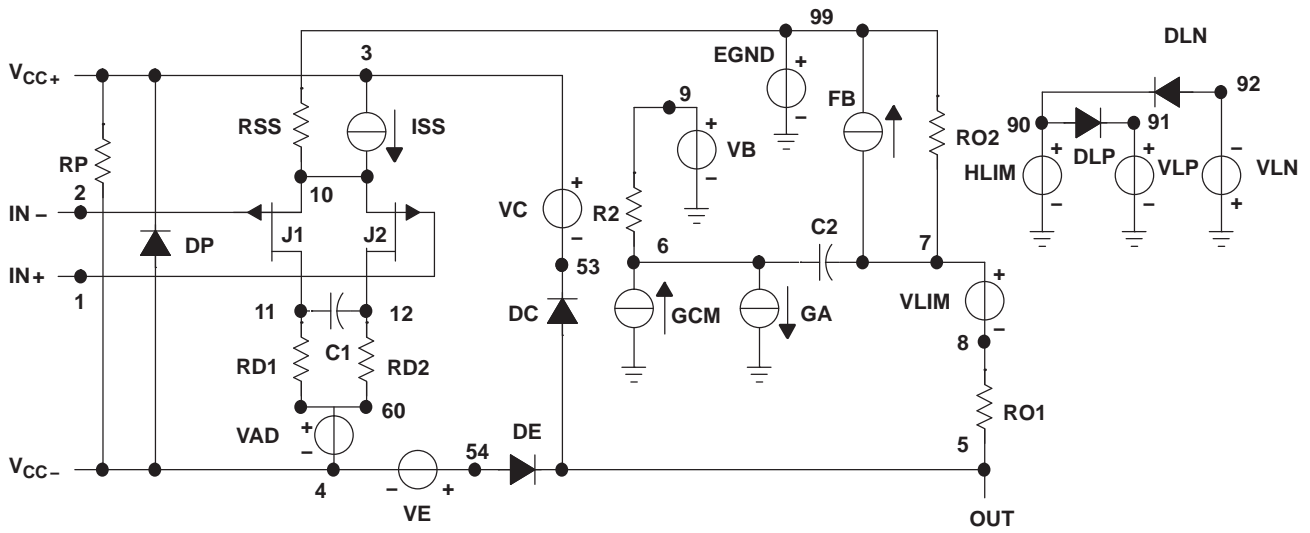

```

.SUBCKT TLV226x 1 2 3 4 5
C1      11  12  5.5E-12
C2      6   7   20.00E-12
DC      5   53  DX
DE      54  5   DX
DLP     90  91  DX
DLN     92  90  DX
DP      4   3   DX
EGND    99  0   POLY (2) (3,0) (4,0) 0 .5 .5
FB      7   99  POLY (5) VB VC VE VLP
+ VLN 0 8.84E6 -10E6 10E6 10E6 -10E6
GA      6   0   11   12 62.83E-6
GCM     0   6   10   99 12.34E-9
ISS     3   10  DC 11.05E-6
HLIM    90  0   VLIM 1K
J1      11  2   10 JX
J2      12  1   10 JX
R2      6   9   100.0E3
RD1     60  11  15.92E3
RD2     60  12  15.92E3
R01     8   5   135
R02     7   99  135
RP      3   4   15.87E3
RSS     10  99  18.18E6
VAD     60  4   -.5
VB      9   0   DC 0
VC      3   53  DC .615
VE      54  4   DC .615
VLIM    7   8   DC 0
VLP     91  0   DC 1
VLN     0   92  DC 5.1
.MODEL DX D (IS=800.0E-18)
.MODEL JX PJF (IS=500.0E-15 BETA=325E-6
+ VTO=-.08)
.ENDS

```

Figure 62. Boyle Macromodel and Subcircuit

**PACKAGING INFORMATION**

| Orderable Device | Status<br>(1) | Package Type | Package Drawing | Pins | Package Qty | Eco Plan<br>(2)         | Lead/Ball Finish | MSL Peak Temp<br>(3) | Op Temp (°C) | Top-Side Markings<br>(4) | Samples        |
|------------------|---------------|--------------|-----------------|------|-------------|-------------------------|------------------|----------------------|--------------|--------------------------|----------------|
| TLV2262AQDRQ1    | OBSOLETE      | SOIC         | D               | 8    |             | TBD                     | Call TI          | Call TI              | -40 to 125   |                          |                |
| TLV2262AQPWRQ1   | ACTIVE        | TSSOP        | PW              | 8    | 2000        | Green (RoHS & no Sb/Br) | CU NIPDAU        | Level-1-260C-UNLIM   | -40 to 125   | TQ262A                   | <b>Samples</b> |
| TLV2262QDRQ1     | OBSOLETE      | SOIC         | D               | 8    |             | TBD                     | Call TI          | Call TI              | -40 to 125   |                          |                |
| TLV2264AQDRQ1    | OBSOLETE      | SOIC         | D               | 14   |             | TBD                     | Call TI          | Call TI              | -40 to 125   |                          |                |
| TLV2264AQPWRQ1   | ACTIVE        | TSSOP        | PW              | 14   | 2000        | Green (RoHS & no Sb/Br) | CU NIPDAU        | Level-1-260C-UNLIM   | -40 to 125   | P2264AQ                  | <b>Samples</b> |
| TLV2264QDRQ1     | OBSOLETE      | SOIC         | D               | 14   |             | TBD                     | Call TI          | Call TI              | -40 to 125   |                          |                |

(1) The marketing status values are defined as follows:

**ACTIVE:** Product device recommended for new designs.

**LIFEBUY:** TI has announced that the device will be discontinued, and a lifetime-buy period is in effect.

**NRND:** Not recommended for new designs. Device is in production to support existing customers, but TI does not recommend using this part in a new design.

**PREVIEW:** Device has been announced but is not in production. Samples may or may not be available.

**OBSOLETE:** TI has discontinued the production of the device.

(2) Eco Plan - The planned eco-friendly classification: Pb-Free (RoHS), Pb-Free (RoHS Exempt), or Green (RoHS & no Sb/Br) - please check <http://www.ti.com/productcontent> for the latest availability information and additional product content details.

**TBD:** The Pb-Free/Green conversion plan has not been defined.

**Pb-Free (RoHS):** TI's terms "Lead-Free" or "Pb-Free" mean semiconductor products that are compatible with the current RoHS requirements for all 6 substances, including the requirement that lead not exceed 0.1% by weight in homogeneous materials. Where designed to be soldered at high temperatures, TI Pb-Free products are suitable for use in specified lead-free processes.

**Pb-Free (RoHS Exempt):** This component has a RoHS exemption for either 1) lead-based flip-chip solder bumps used between the die and package, or 2) lead-based die adhesive used between the die and leadframe. The component is otherwise considered Pb-Free (RoHS compatible) as defined above.

**Green (RoHS & no Sb/Br):** TI defines "Green" to mean Pb-Free (RoHS compatible), and free of Bromine (Br) and Antimony (Sb) based flame retardants (Br or Sb do not exceed 0.1% by weight in homogeneous material)

(3) MSL, Peak Temp. -- The Moisture Sensitivity Level rating according to the JEDEC industry standard classifications, and peak solder temperature.

(4) Multiple Top-Side Markings will be inside parentheses. Only one Top-Side Marking contained in parentheses and separated by a "~" will appear on a device. If a line is indented then it is a continuation of the previous line and the two combined represent the entire Top-Side Marking for that device.

**Important Information and Disclaimer:** The information provided on this page represents TI's knowledge and belief as of the date that it is provided. TI bases its knowledge and belief on information provided by third parties, and makes no representation or warranty as to the accuracy of such information. Efforts are underway to better integrate information from third parties. TI has taken and continues to take reasonable steps to provide representative and accurate information but may not have conducted destructive testing or chemical analysis on incoming materials and chemicals. TI and TI suppliers consider certain information to be proprietary, and thus CAS numbers and other limited information may not be available for release.

In no event shall TI's liability arising out of such information exceed the total purchase price of the TI part(s) at issue in this document sold by TI to Customer on an annual basis.

**OTHER QUALIFIED VERSIONS OF TLV2262-Q1, TLV2262A-Q1, TLV2264-Q1, TLV2264A-Q1 :**

- Catalog: [TLV2262](#), [TLV2262A](#), [TLV2264](#), [TLV2264A](#)
- Military: [TLV2262M](#), [TLV2262AM](#), [TLV2264M](#), [TLV2264AM](#)

NOTE: Qualified Version Definitions:

- Catalog - TI's standard catalog product
- Military - QML certified for Military and Defense Applications

## TAPE AND REEL INFORMATION



### QUADRANT ASSIGNMENTS FOR PIN 1 ORIENTATION IN TAPE



\*All dimensions are nominal

| Device         | Package Type | Package Drawing | Pins | SPQ  | Reel Diameter (mm) | Reel Width W1 (mm) | A0 (mm) | B0 (mm) | K0 (mm) | P1 (mm) | W (mm) | Pin1 Quadrant |
|----------------|--------------|-----------------|------|------|--------------------|--------------------|---------|---------|---------|---------|--------|---------------|
| TLV2264AQPWRQ1 | TSSOP        | PW              | 14   | 2000 | 330.0              | 12.4               | 6.9     | 5.6     | 1.6     | 8.0     | 12.0   | Q1            |

**TAPE AND REEL BOX DIMENSIONS**

\*All dimensions are nominal

| Device         | Package Type | Package Drawing | Pins | SPQ  | Length (mm) | Width (mm) | Height (mm) |
|----------------|--------------|-----------------|------|------|-------------|------------|-------------|
| TLV2264AQPWRQ1 | TSSOP        | PW              | 14   | 2000 | 367.0       | 367.0      | 35.0        |





PW (R-PDSO-G14)

PLASTIC SMALL OUTLINE



4040064-3/G 02/11

- NOTES:
- A. All linear dimensions are in millimeters. Dimensioning and tolerancing per ASME Y14.5M-1994.
  - B. This drawing is subject to change without notice.
  -  Body length does not include mold flash, protrusions, or gate burrs. Mold flash, protrusions, or gate burrs shall not exceed 0,15 each side.
  -  Body width does not include interlead flash. Interlead flash shall not exceed 0,25 each side.
  - E. Falls within JEDEC MO-153

PW (R-PDSO-G14)

PLASTIC SMALL OUTLINE



4211284-2/G 08/15

- NOTES:
- A. All linear dimensions are in millimeters.
  - B. This drawing is subject to change without notice.
  - C. Publication IPC-7351 is recommended for alternate designs.
  - D. Laser cutting apertures with trapezoidal walls and also rounding corners will offer better paste release. Customers should contact their board assembly site for stencil design recommendations. Refer to IPC-7525 for other stencil recommendations.
  - E. Customers should contact their board fabrication site for solder mask tolerances between and around signal pads.



# EXAMPLE BOARD LAYOUT

PW0008A

TSSOP - 1.2 mm max height

SMALL OUTLINE PACKAGE



LAND PATTERN EXAMPLE  
SCALE:10X



SOLDER MASK DETAILS  
NOT TO SCALE

4221848/A 02/2015

NOTES: (continued)

- 6. Publication IPC-7351 may have alternate designs.
- 7. Solder mask tolerances between and around signal pads can vary based on board fabrication site.

# EXAMPLE STENCIL DESIGN

PW0008A

TSSOP - 1.2 mm max height

SMALL OUTLINE PACKAGE



SOLDER PASTE EXAMPLE  
BASED ON 0.125 mm THICK STENCIL  
SCALE:10X

4221848/A 02/2015

NOTES: (continued)

8. Laser cutting apertures with trapezoidal walls and rounded corners may offer better paste release. IPC-7525 may have alternate design recommendations.
9. Board assembly site may have different recommendations for stencil design.

D (R-PDSO-G8)

PLASTIC SMALL OUTLINE

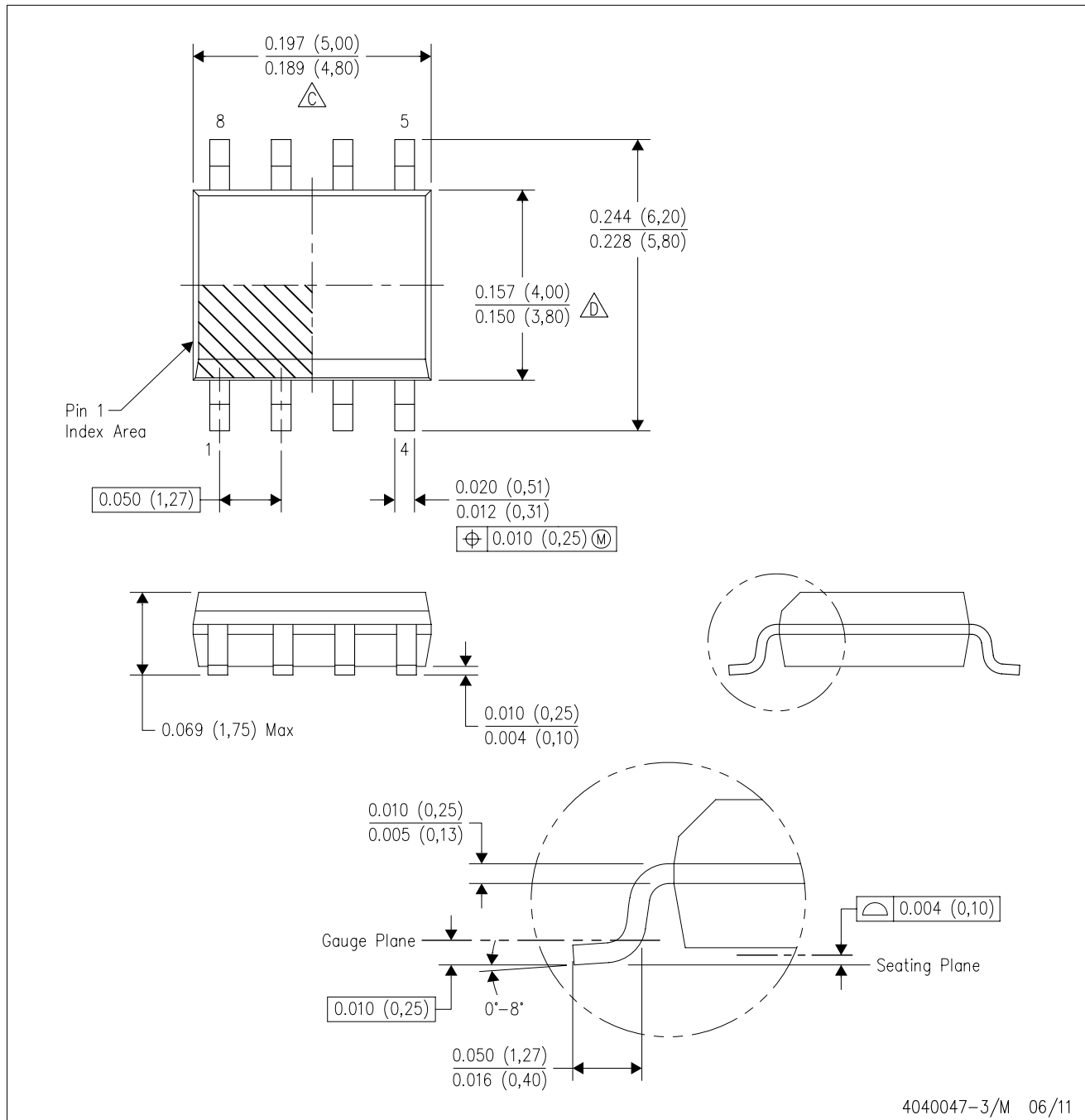

- NOTES:
- A. All linear dimensions are in inches (millimeters).
  - B. This drawing is subject to change without notice.
  - C. Body length does not include mold flash, protrusions, or gate burrs. Mold flash, protrusions, or gate burrs shall not exceed 0.006 (0,15) each side.
  - D. Body width does not include interlead flash. Interlead flash shall not exceed 0.017 (0,43) each side.
  - E. Reference JEDEC MS-012 variation AA.

## IMPORTANT NOTICE

Texas Instruments Incorporated and its subsidiaries (TI) reserve the right to make corrections, enhancements, improvements and other changes to its semiconductor products and services per JESD46, latest issue, and to discontinue any product or service per JESD48, latest issue. Buyers should obtain the latest relevant information before placing orders and should verify that such information is current and complete. All semiconductor products (also referred to herein as "components") are sold subject to TI's terms and conditions of sale supplied at the time of order acknowledgment.

TI warrants performance of its components to the specifications applicable at the time of sale, in accordance with the warranty in TI's terms and conditions of sale of semiconductor products. Testing and other quality control techniques are used to the extent TI deems necessary to support this warranty. Except where mandated by applicable law, testing of all parameters of each component is not necessarily performed.

TI assumes no liability for applications assistance or the design of Buyers' products. Buyers are responsible for their products and applications using TI components. To minimize the risks associated with Buyers' products and applications, Buyers should provide adequate design and operating safeguards.

TI does not warrant or represent that any license, either express or implied, is granted under any patent right, copyright, mask work right, or other intellectual property right relating to any combination, machine, or process in which TI components or services are used. Information published by TI regarding third-party products or services does not constitute a license to use such products or services or a warranty or endorsement thereof. Use of such information may require a license from a third party under the patents or other intellectual property of the third party, or a license from TI under the patents or other intellectual property of TI.

Reproduction of significant portions of TI information in TI data books or data sheets is permissible only if reproduction is without alteration and is accompanied by all associated warranties, conditions, limitations, and notices. TI is not responsible or liable for such altered documentation. Information of third parties may be subject to additional restrictions.

Resale of TI components or services with statements different from or beyond the parameters stated by TI for that component or service voids all express and any implied warranties for the associated TI component or service and is an unfair and deceptive business practice. TI is not responsible or liable for any such statements.

Buyer acknowledges and agrees that it is solely responsible for compliance with all legal, regulatory and safety-related requirements concerning its products, and any use of TI components in its applications, notwithstanding any applications-related information or support that may be provided by TI. Buyer represents and agrees that it has all the necessary expertise to create and implement safeguards which anticipate dangerous consequences of failures, monitor failures and their consequences, lessen the likelihood of failures that might cause harm and take appropriate remedial actions. Buyer will fully indemnify TI and its representatives against any damages arising out of the use of any TI components in safety-critical applications.

In some cases, TI components may be promoted specifically to facilitate safety-related applications. With such components, TI's goal is to help enable customers to design and create their own end-product solutions that meet applicable functional safety standards and requirements. Nonetheless, such components are subject to these terms.

No TI components are authorized for use in FDA Class III (or similar life-critical medical equipment) unless authorized officers of the parties have executed a special agreement specifically governing such use.

Only those TI components which TI has specifically designated as military grade or "enhanced plastic" are designed and intended for use in military/aerospace applications or environments. Buyer acknowledges and agrees that any military or aerospace use of TI components which have **not** been so designated is solely at the Buyer's risk, and that Buyer is solely responsible for compliance with all legal and regulatory requirements in connection with such use.

TI has specifically designated certain components as meeting ISO/TS16949 requirements, mainly for automotive use. In any case of use of non-designated products, TI will not be responsible for any failure to meet ISO/TS16949.

### Products

|                              |  |
|------------------------------|--|
| Audio                        | <a href="http://www.ti.com/audio">www.ti.com/audio</a>                               |
| Amplifiers                   | <a href="http://amplifier.ti.com">amplifier.ti.com</a>                               |
| Data Converters              | <a href="http://dataconverter.ti.com">dataconverter.ti.com</a>                       |
| DLP® Products                | <a href="http://www.dlp.com">www.dlp.com</a>   |
| DSP                          | <a href="http://dsp.ti.com">dsp.ti.com</a>   |
| Clocks and Timers            | <a href="http://www.ti.com/clocks">www.ti.com/clocks</a>                             |
| Interface                    | <a href="http://interface.ti.com">interface.ti.com</a>                               |
| Logic                        | <a href="http://logic.ti.com">logic.ti.com</a>                                       |
| Power Mgmt                   | <a href="http://power.ti.com">power.ti.com</a>                                       |
| Microcontrollers             | <a href="http://microcontroller.ti.com">microcontroller.ti.com</a>                   |
| RFID                         | <a href="http://www.ti-rfid.com">www.ti-rfid.com</a>                                 |
| OMAP Applications Processors | <a href="http://www.ti.com/omap">www.ti.com/omap</a>                                 |
| Wireless Connectivity        | <a href="http://www.ti.com/wirelessconnectivity">www.ti.com/wirelessconnectivity</a> |

### Applications

|                               |  |
|-------------------------------|--|
| Automotive and Transportation | <a href="http://www.ti.com/automotive">www.ti.com/automotive</a>                         |
| Communications and Telecom    | <a href="http://www.ti.com/communications">www.ti.com/communications</a>                 |
| Computers and Peripherals     | <a href="http://www.ti.com/computers">www.ti.com/computers</a>                           |
| Consumer Electronics          | <a href="http://www.ti.com/consumer-apps">www.ti.com/consumer-apps</a>                   |
| Energy and Lighting           | <a href="http://www.ti.com/energy">www.ti.com/energy</a>                                 |
| Industrial                    | <a href="http://www.ti.com/industrial">www.ti.com/industrial</a>                         |
| Medical                       | <a href="http://www.ti.com/medical">www.ti.com/medical</a>                               |
| Security                      | <a href="http://www.ti.com/security">www.ti.com/security</a>                             |
| Space, Avionics and Defense   | <a href="http://www.ti.com/space-avionics-defense">www.ti.com/space-avionics-defense</a> |
| Video and Imaging             | <a href="http://www.ti.com/video">www.ti.com/video</a>                                   |

### TI E2E Community

[e2e.ti.com](http://e2e.ti.com)