

TLV431A-Q1, TLV431B-Q1 LOW-VOLTAGE ADJUSTABLE PRECISION SHUNT REGULATORS

SLVS905 – DECEMBER 2008

- Qualified for Automotive Applications
- Low-Voltage Operation: $V_{REF} = 1.24\text{ V}$
- Adjustable Output Voltage, $V_O = V_{REF}$ to 6 V
- Reference Voltage Tolerances at 25°C
 - 0.5% for TLV431B
 - 1% for TLV431A
- Typical Temperature Drift: 11 mV
- Low Operational Cathode Current :80 μA Typ
- 0.25- Ω Typical Output Impedance
- See TLVH431 and TLVH432 for
 - Wider V_{KA} (1.24 V to 18 V) and I_K (80 mA)
 - Additional SOT-89 Package
 - Multiple Pinouts for SOT-23-3 and SOT-89 Packages

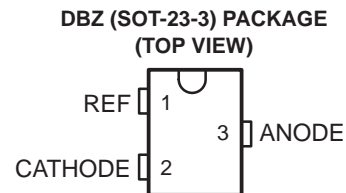
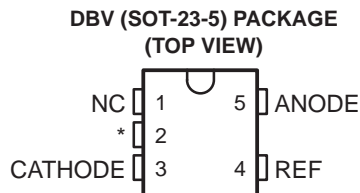

NC – No internal connection

* For TLV431A: NC – No internal connection

* For TLV431B: Pin 2 is attached to Substrate and must be connected to ANODE or left open.

description/ordering information

The TLV431 is a low-voltage 3-terminal adjustable voltage reference with specified thermal stability over applicable industrial and commercial temperature ranges. Output voltage can be set to any value between V_{REF} (1.24 V) and 6 V with two external resistors (see Figure 2). These devices operate from a lower voltage (1.24 V) than the widely used TL431 and TL1431 shunt-regulator references.

When used with an optocoupler, the TLV431 is an ideal voltage reference in isolated feedback circuits for 3-V to 3.3-V switching-mode power supplies. These devices have a typical output impedance of 0.25 Ω . Active output circuitry provides a very sharp turn-on characteristic, making them excellent replacements for low-voltage Zener diodes in many applications, including on-board regulation and adjustable power supplies.

ORDERING INFORMATION

T_J	25°C V_{REF} TOLERANCE	PACKAGE†		ORDERABLE PART NUMBER	TOP-SIDE MARKING
–40°C to 125°C	0.5%	SOT-23-5 (DBV)	Reel of 3000	TLV431BQDBVRQ1	VOMQ
		SOT-23-3 (DBZ)	Reel of 3000	TLV431BQDBZRQ1	VOQQ
	1%	SOT-23-5 (DBV)	Reel of 3000	TLV431AQDBVRQ1	VONQ

† For the most current package and ordering information, see the Package Option Addendum at the end of this document, or see the TI web site at <http://www.ti.com>.

‡ Package drawings, thermal data, and symbolization are available at <http://www.ti.com/packaging>.



Please be aware that an important notice concerning availability, standard warranty, and use in critical applications of Texas Instruments semiconductor products and disclaimers thereto appears at the end of this data sheet.

PRODUCTION DATA information is current as of publication date. Products conform to specifications per the terms of Texas Instruments standard warranty. Production processing does not necessarily include testing of all parameters.

 **TEXAS
INSTRUMENTS**

POST OFFICE BOX 655303 • DALLAS, TEXAS 75265

Copyright © 2008, Texas Instruments Incorporated

TLV431A-Q1, TLV431B-Q1 LOW-VOLTAGE ADJUSTABLE PRECISION SHUNT REGULATORS

SLVS905 – DECEMBER 2008

logic block diagram

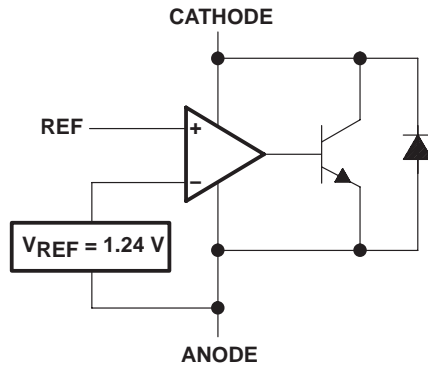

equivalent schematic

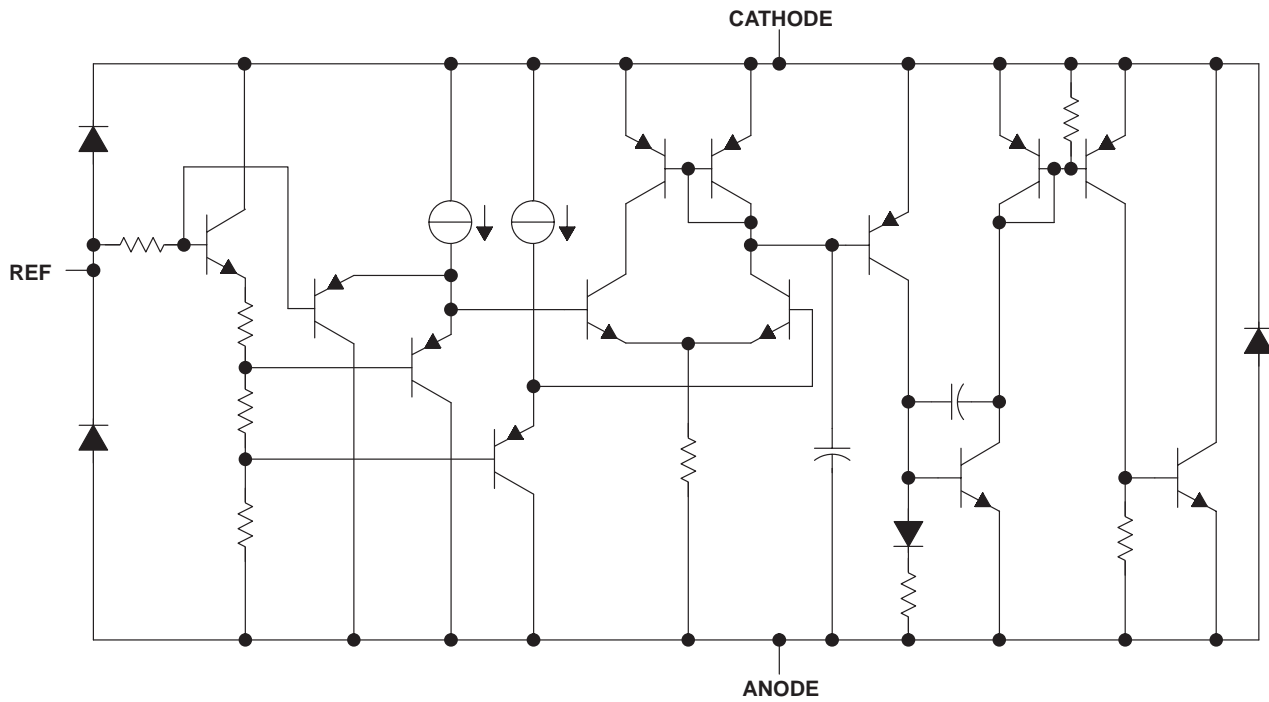

TLV431A-Q1, TLV431B-Q1

LOW-VOLTAGE ADJUSTABLE PRECISION SHUNT REGULATORS

SLVS905 – DECEMBER 2008

absolute maximum ratings over operating free-air temperature range (unless otherwise noted)†

Cathode voltage, V_{KA} (see Note 1)	7 V
Continuous cathode current range, I_K	–20 mA to 20 mA
Reference current range, I_{ref}	–0.05 mA to 3 mA
Package thermal impedance, θ_{JA} (see Notes 2 and 3): DBV package	206°C/W
DBZ package	206°C/W
Operating virtual junction temperature	150°C
Storage temperature range, T_{stg}	–65°C to 150°C

† Stresses beyond those listed under “absolute maximum ratings” may cause permanent damage to the device. These are stress ratings only, and functional operation of the device at these or any other conditions beyond those indicated under “recommended operating conditions” is not implied. Exposure to absolute-maximum-rated conditions for extended periods may affect device reliability.

- NOTES:
1. Voltage values are with respect to the anode terminal, unless otherwise noted.
 2. Maximum power dissipation is a function of $T_J(max)$, θ_{JA} , and T_A . The maximum allowable power dissipation at any allowable ambient temperature is $P_D = (T_J(max) - T_A)/\theta_{JA}$. Operating at the absolute maximum T_J of 150°C can affect reliability.
 3. The package thermal impedance is calculated in accordance with JESD 51-7.

recommended operating conditions

	MIN	MAX	UNIT
V_{KA} Cathode voltage	V_{REF}	6	V
I_K Cathode current	0.1	15	mA
T_A Operating free-air temperature range	–40	125	°C



TLV431A-Q1, TLV431B-Q1

LOW-VOLTAGE ADJUSTABLE PRECISION SHUNT REGULATORS

SLVS905 – DECEMBER 2008

TLV431A electrical characteristics at 25°C free-air temperature (unless otherwise noted)

PARAMETER	TEST CONDITIONS	TLV431A			UNIT
		MIN	TYP	MAX	
V _{REF} Reference voltage	V _K A = V _{REF} , I _K = 10 mA, T _A = 25°C	1.228	1.24	1.252	V
	T _A = full range† (see Figure 1)	1.209		1.271	
V _{REF(dev)} V _{REF} deviation over full temperature range†‡	V _K A = V _{REF} , I _K = 10 mA (see Figure 1)		11	31	mV
$\frac{\Delta V_{REF}}{\Delta V_{KA}}$ Ratio of V _{REF} change in cathode voltage change	V _K A = V _{REF} to 6 V, I _K = 10 mA (see Figure 2)		-1.5	-2.7	mV/V
I _{ref} Reference terminal current	I _K = 10 mA, R1 = 10 kΩ, R2 = open (see Figure 2)		0.15	0.5	μA
I _{ref(dev)} I _{ref} deviation over full temperature range†	I _K = 10 mA, R1 = 10 kΩ, R2 = open (see Figure 2)		0.15	0.5	μA
I _{K(min)} Minimum cathode current for regulation	V _K A = V _{REF} (see Figure 1)		55	100	μA
I _{K(off)} Off-state cathode current	V _{REF} = 0, V _K A = 6 V (see Figure 3)		0.001	0.1	μA
z _{KA} Dynamic impedance §	V _K A = V _{REF} , f ≤ 1 kHz, I _K = 0.1 mA to 15 mA (see Figure 1)		0.25	0.4	Ω

† Full temperature range is -40°C to 125°C.

‡ The deviation parameters V_{REF(dev)} and I_{ref(dev)} are defined as the differences between the maximum and minimum values obtained over the rated temperature range. The average full-range temperature coefficient of the reference input voltage, αV_{REF}, is defined as:

$$|\alpha V_{REF}| \left(\frac{\text{ppm}}{^\circ\text{C}} \right) = \frac{\left(\frac{V_{REF(dev)}}{V_{REF}(T_A=25^\circ\text{C})} \right) \times 10^6}{\Delta T_A}$$

where ΔT_A is the rated operating free-air temperature range of the device.

αV_{REF} can be positive or negative, depending on whether minimum V_{REF} or maximum V_{REF}, respectively, occurs at the lower temperature.

§ The dynamic impedance is defined as $|z_{ka}| = \frac{\Delta V_{KA}}{\Delta I_K}$

When the device is operating with two external resistors (see Figure 2), the total dynamic impedance of the circuit is defined as:

$$|z_{ka}'| = \frac{\Delta V}{\Delta I} \approx |z_{ka}| \times \left(1 + \frac{R1}{R2} \right)$$



TLV431A-Q1, TLV431B-Q1 LOW-VOLTAGE ADJUSTABLE PRECISION SHUNT REGULATORS

SLVS905 – DECEMBER 2008

TLV431B electrical characteristics at 25°C free-air temperature (unless otherwise noted)

PARAMETER	TEST CONDITIONS	TLV431B			UNIT	
		MIN	TYP	MAX		
V _{REF} Reference voltage	V _{KA} = V _{REF} , I _K = 10 mA	T _A = 25°C	1.234	1.24	1.246	V
		T _A = full range† (see Figure 1)	1.221		1.265	
V _{REF(dev)} V _{REF} deviation over full temperature range†‡	V _{KA} = V _{REF} , I _K = 10 mA (see Figure 1)			11	31	mV
$\frac{\Delta V_{REF}}{\Delta V_{KA}}$ Ratio of V _{REF} change in cathode voltage change	V _{KA} = V _{REF} to 6 V, I _K = 10 mA (see Figure 2)			-1.5	-2.7	mV/V
I _{ref} Reference terminal current	I _K = 10 mA, R1 = 10 kΩ, R2 = open (see Figure 2)			0.1	0.5	μA
I _{ref(dev)} I _{ref} deviation over full temperature range†‡	I _K = 10 mA, R1 = 10 kΩ, R2 = open (see Figure 2)			0.15	0.5	μA
I _{K(min)} Minimum cathode current for regulation	V _{KA} = V _{REF} (see Figure 1)			55	100	μA
I _{K(off)} Off-state cathode current	V _{REF} = 0, V _{KA} = 6 V (see Figure 3)			0.001	0.1	μA
z _{KA} Dynamic impedance §	V _{KA} = V _{REF} , f ≤ 1 kHz, I _K = 0.1 mA to 15 mA (see Figure 1)			0.25	0.4	Ω

† Full temperature range is -40°C to 125°C.

‡ The deviation parameters V_{REF(dev)} and I_{ref(dev)} are defined as the differences between the maximum and minimum values obtained over the rated temperature range. The average full-range temperature coefficient of the reference input voltage, αV_{REF}, is defined as:

$$|\alpha V_{REF}| \left(\frac{\text{ppm}}{^{\circ}\text{C}} \right) = \frac{\left(\frac{V_{REF(dev)}}{V_{REF}(T_A=25^{\circ}\text{C})} \right) \times 10^6}{\Delta T_A}$$

where ΔT_A is the rated operating free-air temperature range of the device.

αV_{REF} can be positive or negative, depending on whether minimum V_{REF} or maximum V_{REF}, respectively, occurs at the lower temperature.

§ The dynamic impedance is defined as $|z_{ka}| = \frac{\Delta V_{KA}}{\Delta I_K}$

When the device is operating with two external resistors (see Figure 2), the total dynamic impedance of the circuit is defined as:

$$|z_{ka}'| = \frac{\Delta V}{\Delta I} \approx |z_{ka}| \times \left(1 + \frac{R1}{R2} \right)$$

TLV431A-Q1, TLV431B-Q1 LOW-VOLTAGE ADJUSTABLE PRECISION SHUNT REGULATORS

SLVS905 – DECEMBER 2008

PARAMETER MEASUREMENT INFORMATION

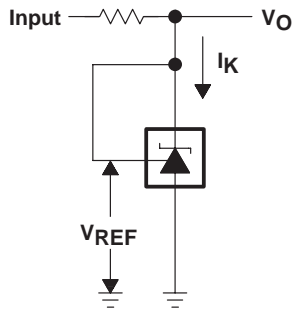

Figure 1. Test Circuit for $V_{KA} = V_{REF}$
 $V_O = V_{KA} = V_{REF}$

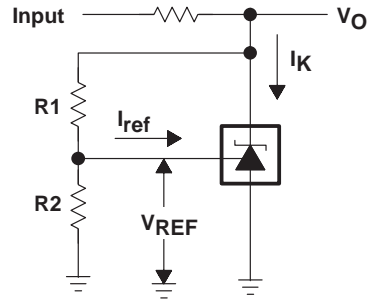

Figure 2. Test Circuit for $V_{KA} > V_{REF}$
 $V_O = V_{KA} = V_{REF} \times (1 + R1/R2) + I_{ref} \times R1$

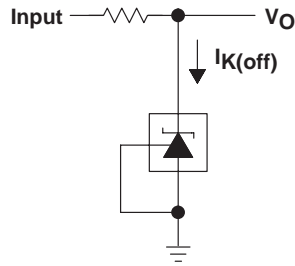

Figure 3. Test Circuit for $I_{K(off)}$

PARAMETER MEASUREMENT INFORMATION†

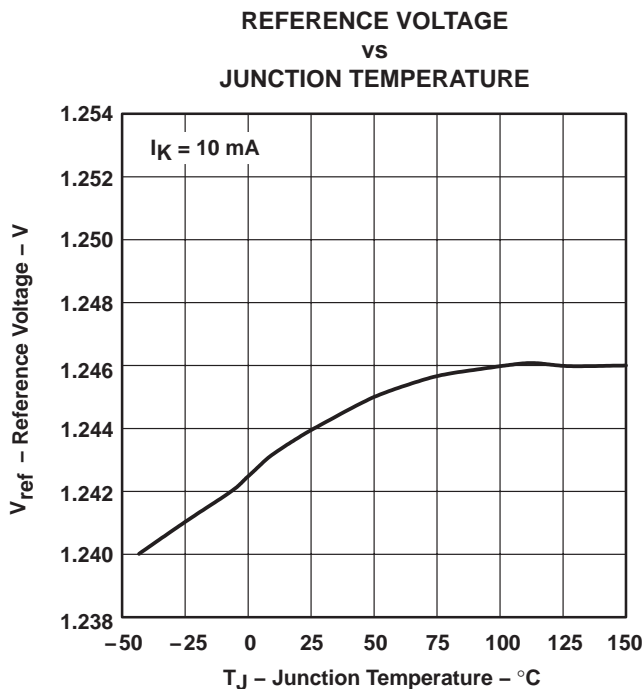

Figure 4

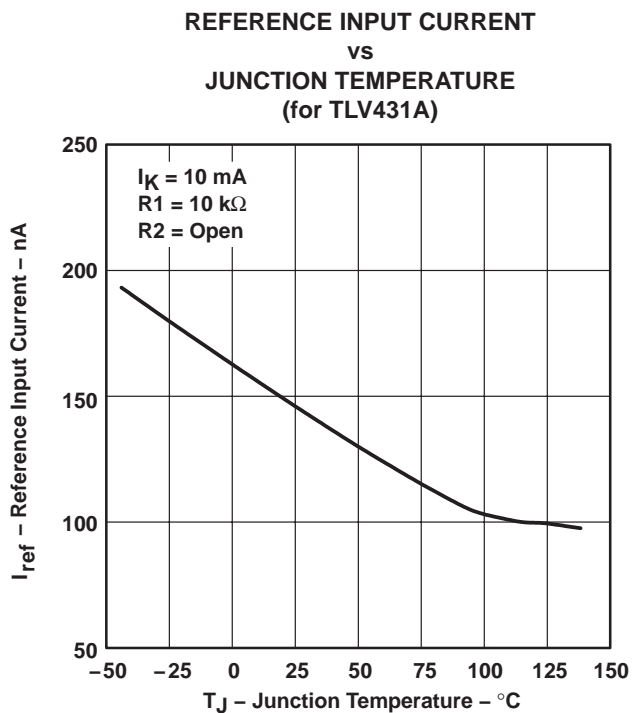

Figure 5A

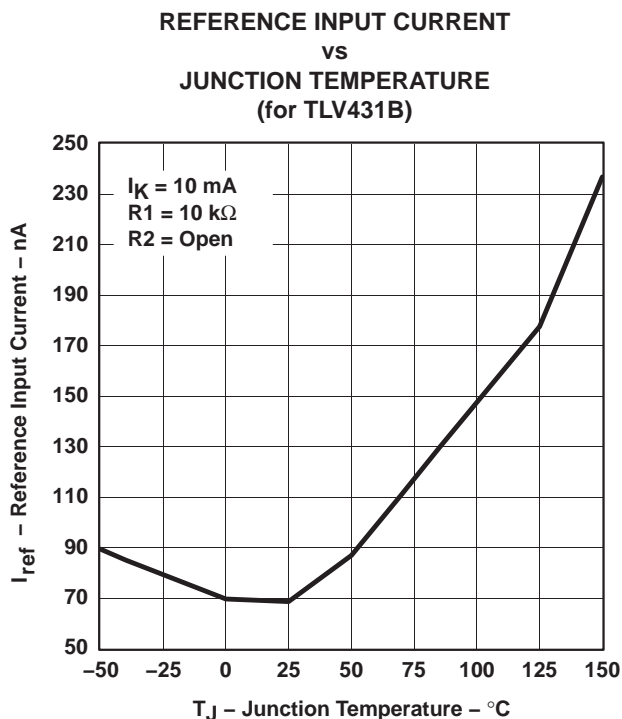

Figure 5B

† Operation of the device at these or any other conditions beyond those indicated under “recommended operating conditions” is not implied.

TLV431A-Q1, TLV431B-Q1 LOW-VOLTAGE ADJUSTABLE PRECISION SHUNT REGULATORS

SLVS905 – DECEMBER 2008

PARAMETER MEASUREMENT INFORMATION†

CATHODE CURRENT
vs
CATHODE VOLTAGE

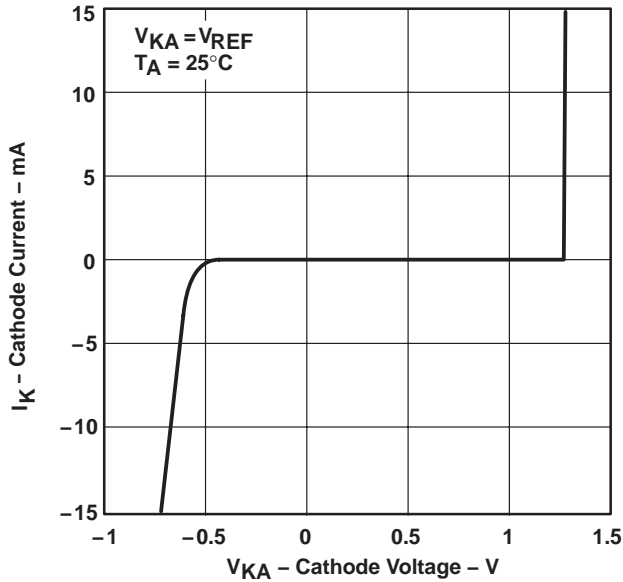

Figure 6

CATHODE CURRENT
vs
CATHODE VOLTAGE

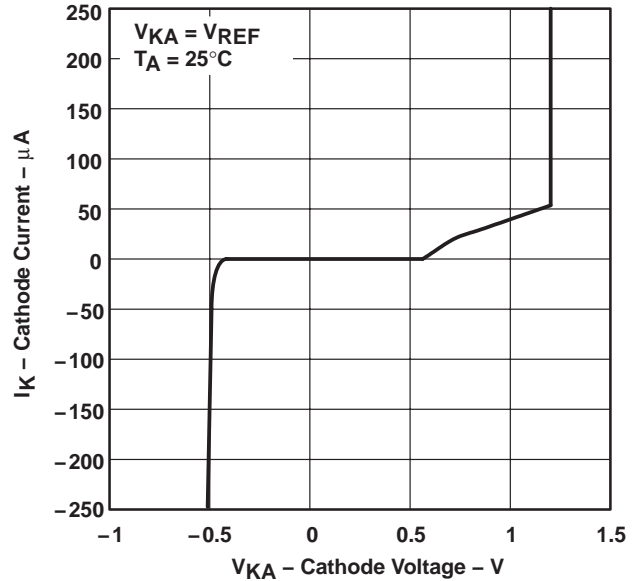

Figure 7

OFF-STATE CATHODE CURRENT
vs
JUNCTION TEMPERATURE
(for TLV431A)

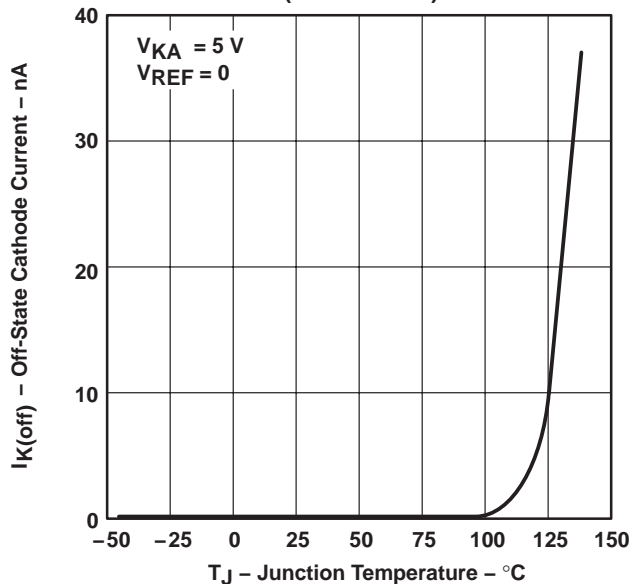

Figure 8A

OFF-STATE CATHODE CURRENT
vs
JUNCTION TEMPERATURE
(for TLV431B)

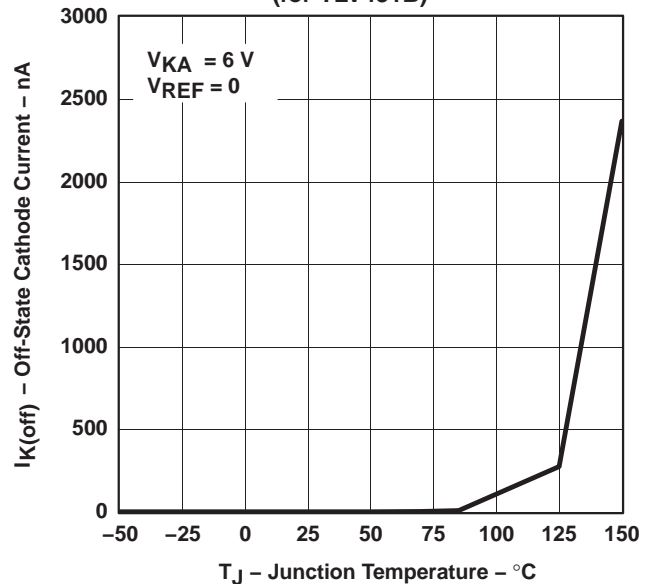

Figure 8B

† Operation of the device at these or any other conditions beyond those indicated under “recommended operating conditions” is not implied.

PARAMETER MEASUREMENT INFORMATION†

RATIO OF DELTA REFERENCE VOLTAGE
 TO DELTA CATHODE VOLTAGE
 vs
 JUNCTION TEMPERATURE
 (for TLV431A)

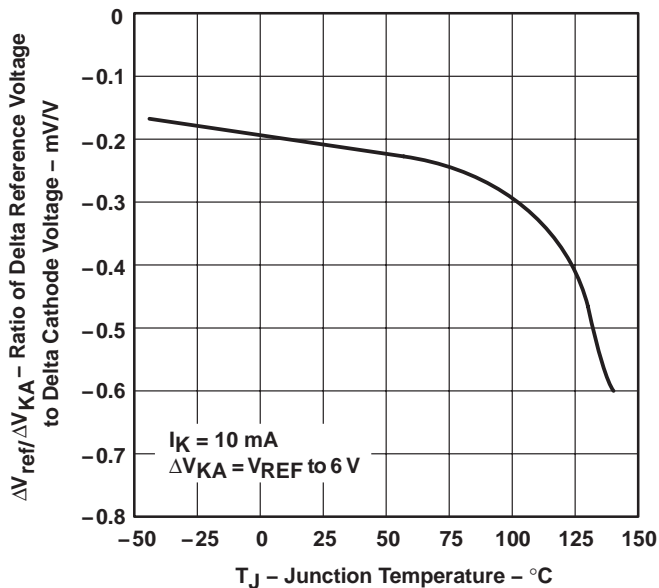

Figure 9A

RATIO OF DELTA REFERENCE VOLTAGE
 TO DELTA CATHODE VOLTAGE
 vs
 JUNCTION TEMPERATURE
 (for TLV431B)

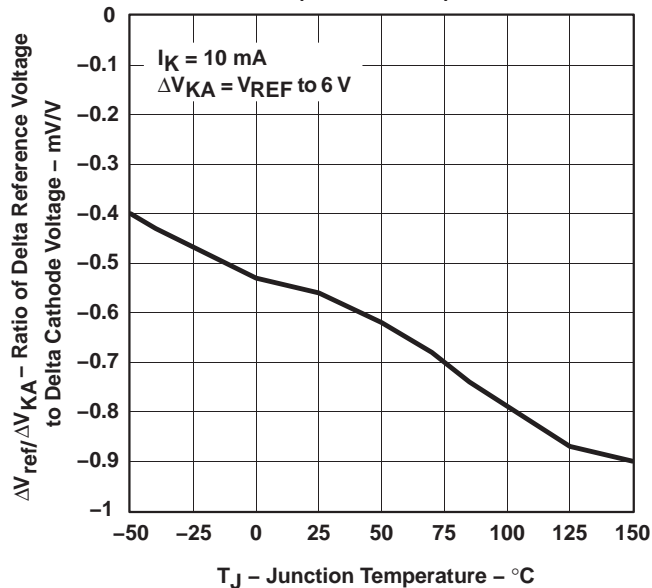
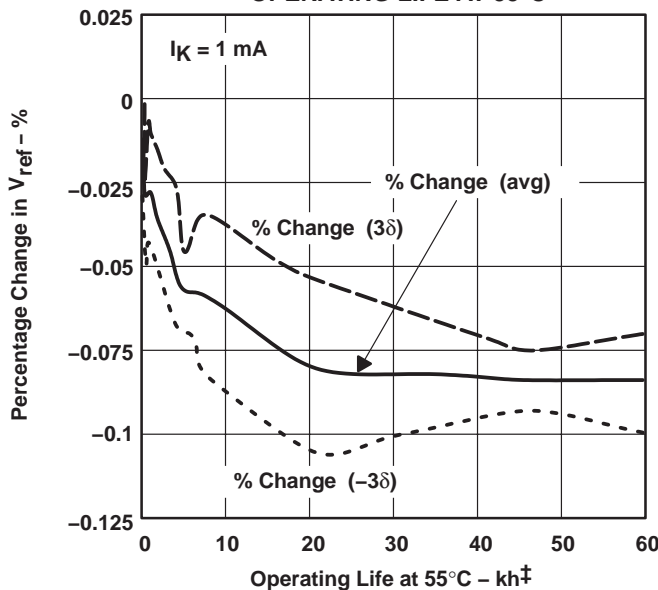

Figure 9B

PERCENTAGE CHANGE IN V_{REF}
 vs
 OPERATING LIFE AT 55°C



‡ Extrapolated from life-test data taken at 125°C; the activation energy assumed is 0.7 eV.

Figure 10

† Operation of the device at these or any other conditions beyond those indicated under “recommended operating conditions” is not implied.

TLV431A-Q1, TLV431B-Q1 LOW-VOLTAGE ADJUSTABLE PRECISION SHUNT REGULATORS

SLVS905 – DECEMBER 2008

PARAMETER MEASUREMENT INFORMATION

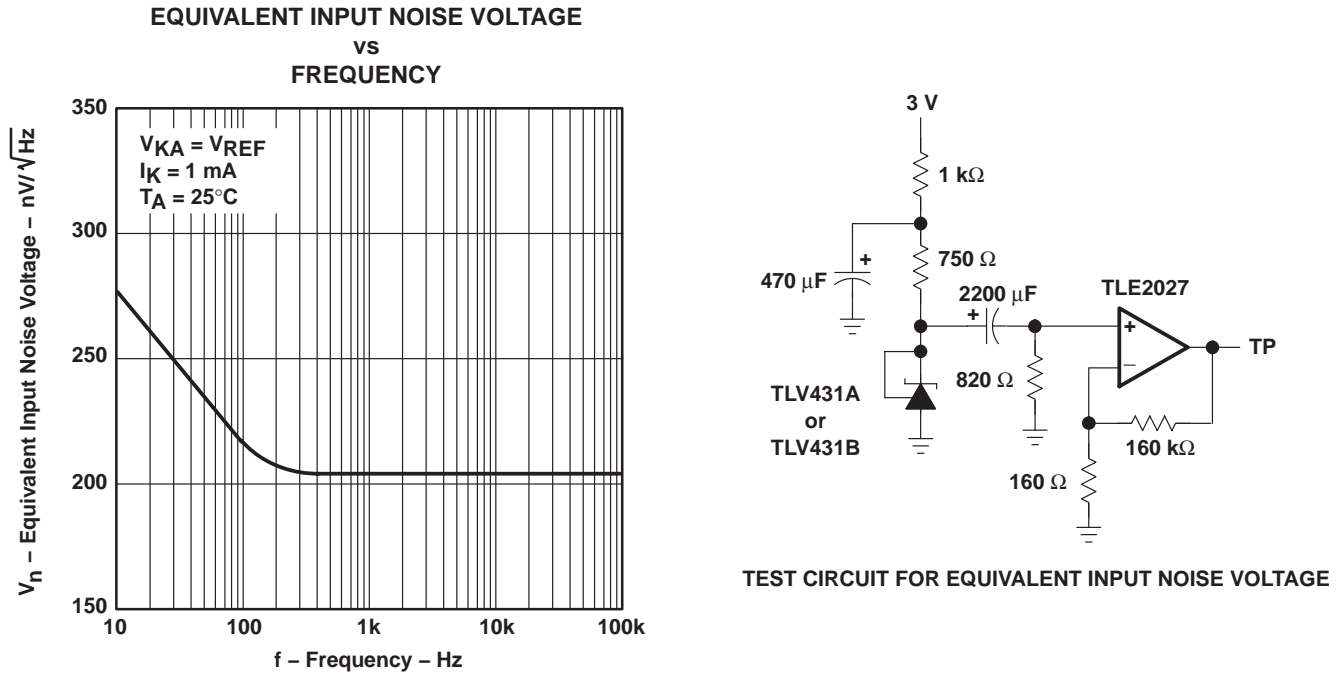
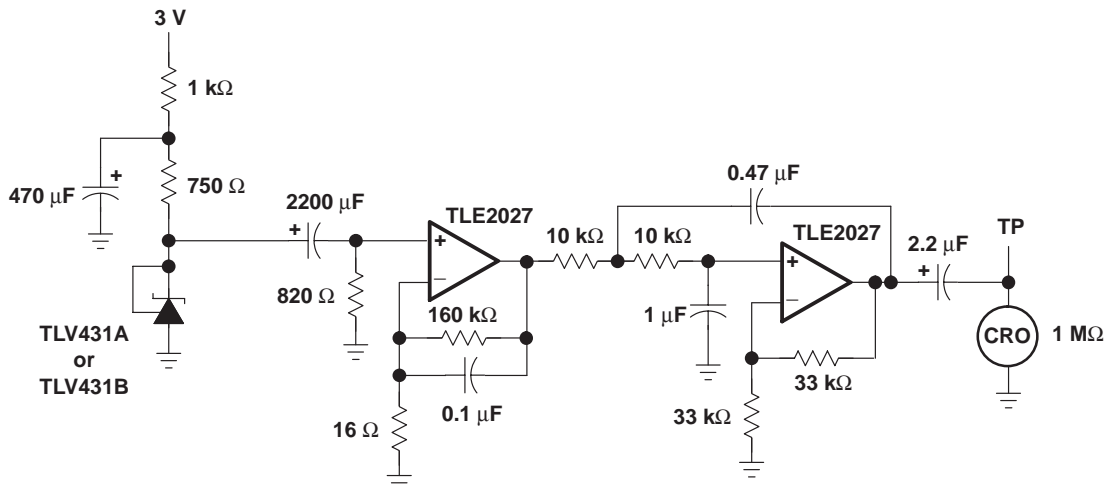
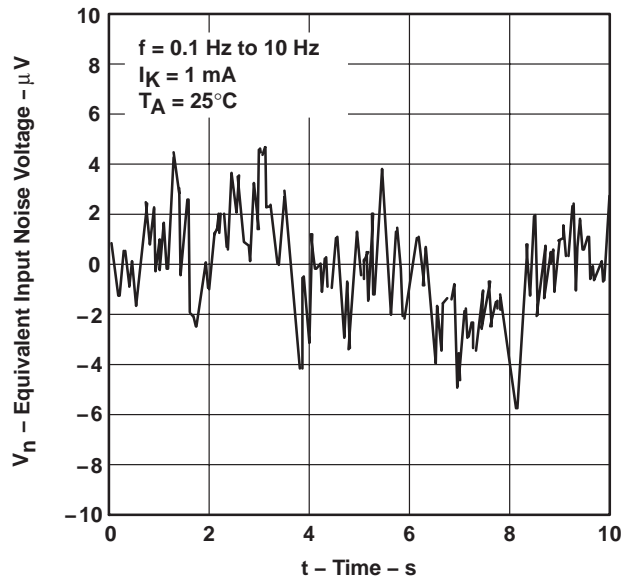

Figure 11

PARAMETER MEASUREMENT INFORMATION

EQUIVALENT INPUT NOISE VOLTAGE
 OVER A 10-s PERIOD



TEST CIRCUIT FOR 0.1-Hz TO 10-Hz EQUIVALENT NOISE VOLTAGE

Figure 12

TLV431A-Q1, TLV431B-Q1 LOW-VOLTAGE ADJUSTABLE PRECISION SHUNT REGULATORS

SLVS905 – DECEMBER 2008

PARAMETER MEASUREMENT INFORMATION

SMALL-SIGNAL VOLTAGE GAIN/PHASE MARGIN vs FREQUENCY

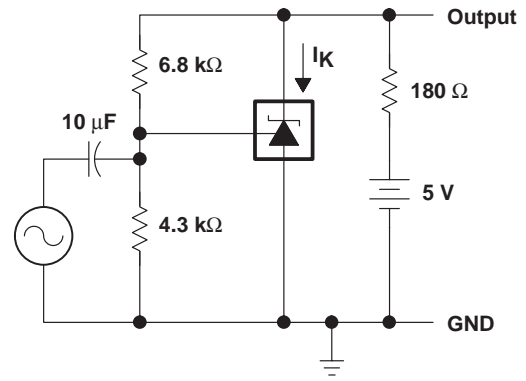
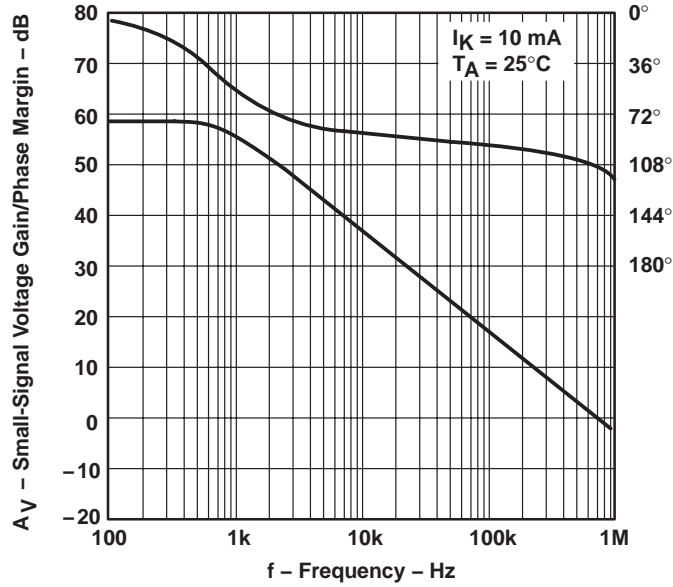

TEST CIRCUIT FOR VOLTAGE GAIN AND PHASE MARGIN

Figure 13

REFERENCE IMPEDANCE vs FREQUENCY

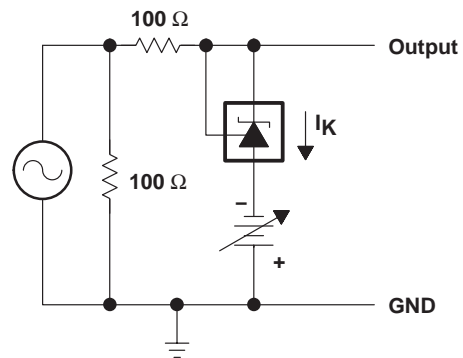
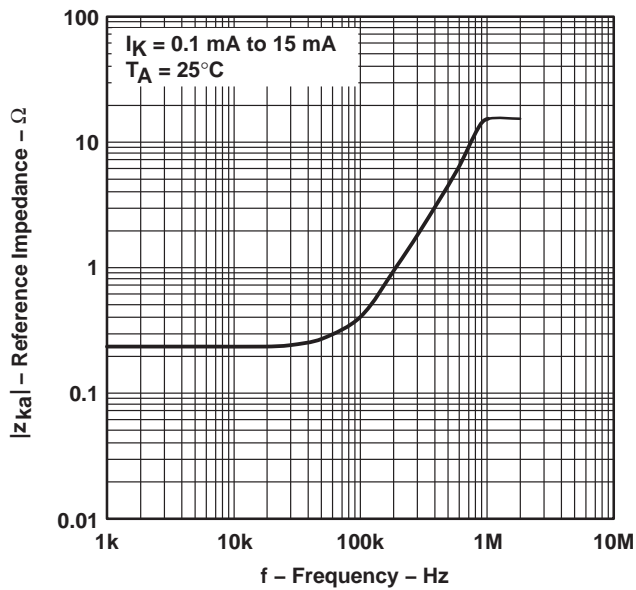

TEST CIRCUIT FOR REFERENCE IMPEDANCE

Figure 14

PARAMETER MEASUREMENT INFORMATION

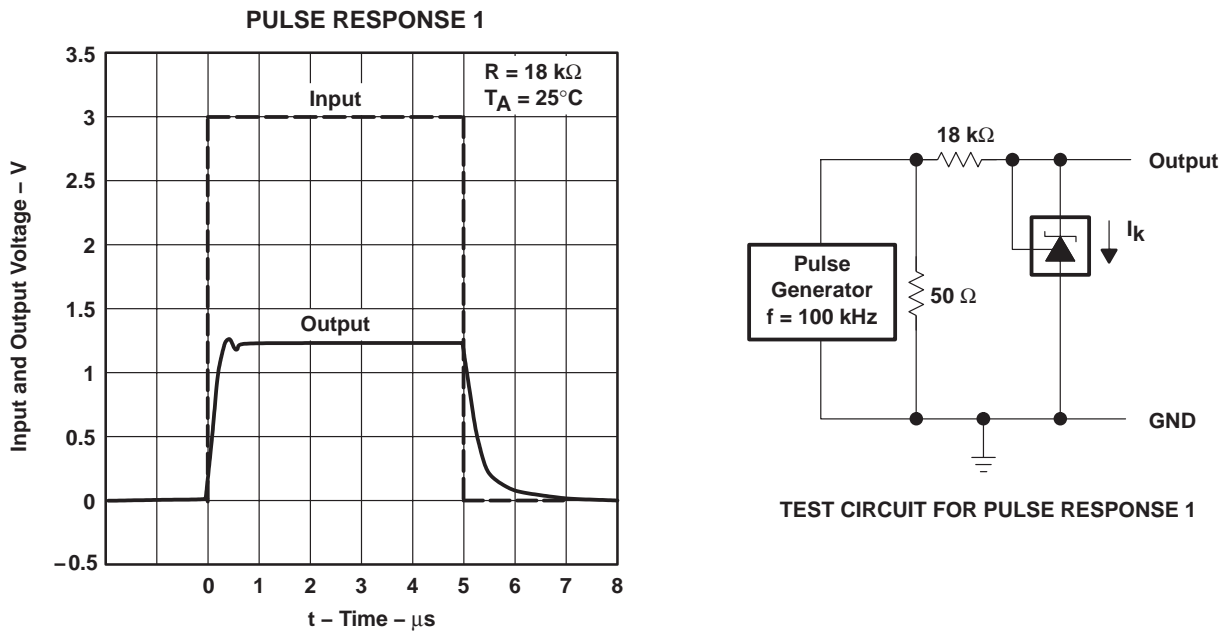

Figure 15

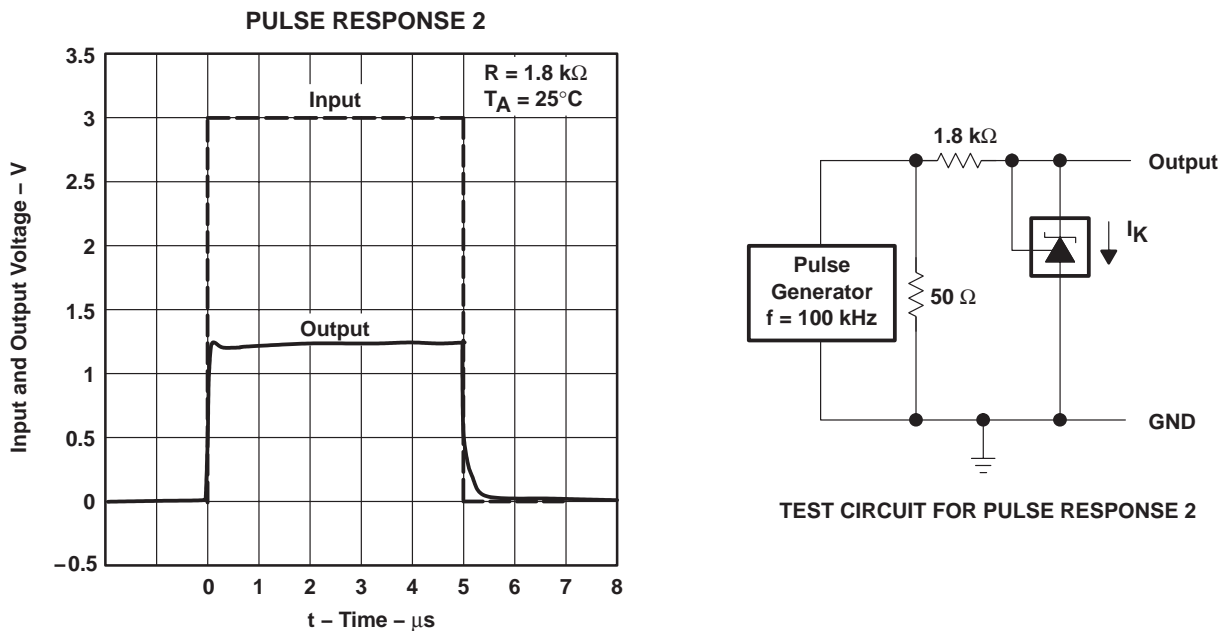
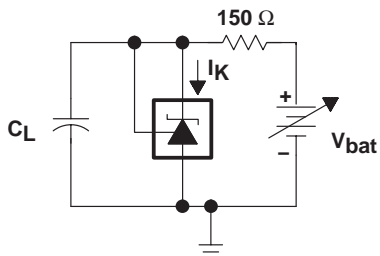
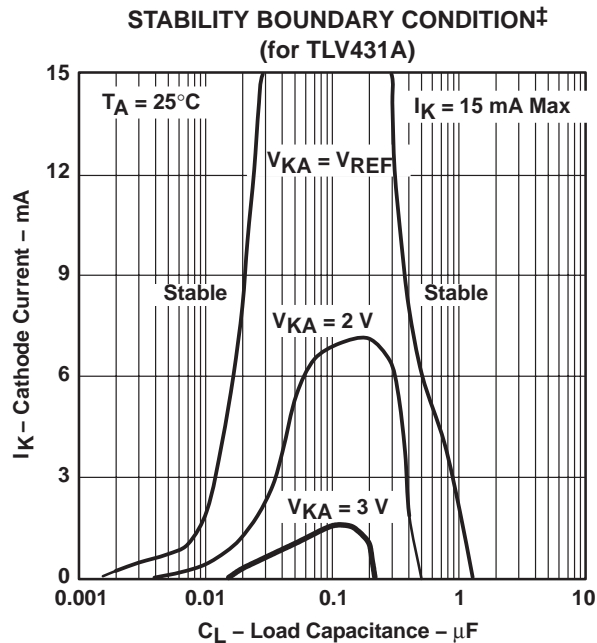

Figure 16

TLV431A-Q1, TLV431B-Q1 LOW-VOLTAGE ADJUSTABLE PRECISION SHUNT REGULATORS

SLVS905 – DECEMBER 2008

PARAMETER MEASUREMENT INFORMATION†



TEST CIRCUIT FOR $V_{KA} = V_{REF}$

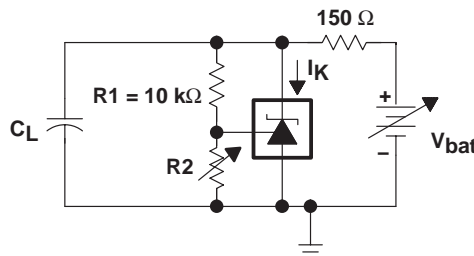
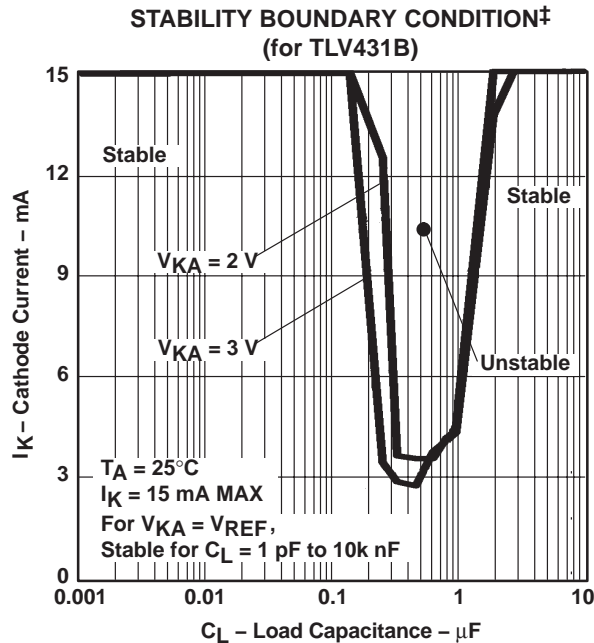

TEST CIRCUIT FOR $V_{KA} = 2\text{ V}, 3\text{ V}$

‡ The areas under the curves represent conditions that may cause the device to oscillate. For $V_{KA} = 2\text{-V}$ and 3-V curves, R_2 and V_{bat} were adjusted to establish the initial V_{KA} and I_K conditions with $C_L = 0$. V_{bat} and C_L then were adjusted to determine the ranges of stability.

Figure 17

† Operation of the device at these or any other conditions beyond those indicated under "recommended operating conditions" is not implied.

APPLICATION INFORMATION

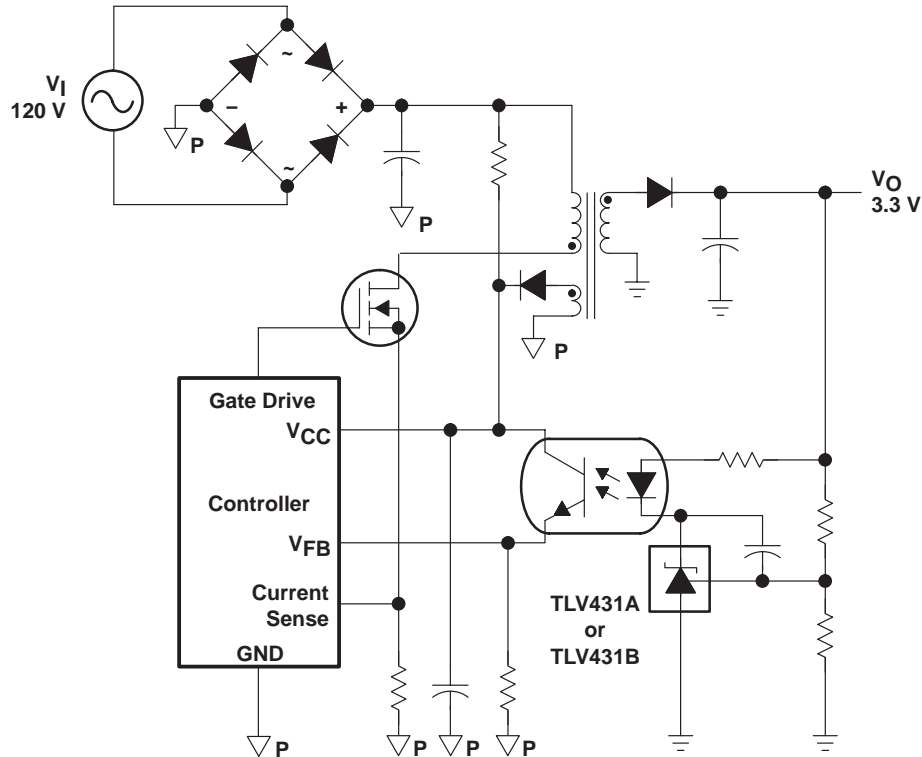

Figure 18. Flyback With Isolation Using TLV431, TLV431A, or TLV431B as Voltage Reference and Error Amplifier

Figure 18 shows the TLV431, TLV431A, or TLV431B used in a 3.3-V isolated flyback supply. Output voltage V_O can be as low as reference voltage V_{REF} ($1.24\text{ V} \pm 1\%$). The output of the regulator, plus the forward voltage drop of the optocoupler LED ($1.24 + 1.4 = 2.64\text{ V}$), determine the minimum voltage that can be regulated in an isolated supply configuration. Regulated voltage as low as 2.7 Vdc is possible in the topology shown in Figure 18.

PACKAGING INFORMATION

Orderable Device	Status (1)	Package Type	Package Drawing	Pins	Package Qty	Eco Plan (2)	Lead/Ball Finish	MSL Peak Temp (3)	Op Temp (°C)	Top-Side Markings (4)	Samples
TLV431AQDBVRQ1	ACTIVE	SOT-23	DBV	5	3000	Green (RoHS & no Sb/Br)	CU NIPDAU	Level-1-260C-UNLIM	-40 to 125	VONQ	Samples
TLV431BQDBVRQ1	ACTIVE	SOT-23	DBV	5	3000	Green (RoHS & no Sb/Br)	CU NIPDAU	Level-1-260C-UNLIM	-40 to 125	VOMQ	Samples
TLV431BQDBZRQ1	ACTIVE	SOT-23	DBZ	3	3000	Green (RoHS & no Sb/Br)	CU NIPDAU	Level-1-260C-UNLIM	-40 to 125	VOQQ	Samples

(1) The marketing status values are defined as follows:

ACTIVE: Product device recommended for new designs.

LIFEBUY: TI has announced that the device will be discontinued, and a lifetime-buy period is in effect.

NRND: Not recommended for new designs. Device is in production to support existing customers, but TI does not recommend using this part in a new design.

PREVIEW: Device has been announced but is not in production. Samples may or may not be available.

OBSELETE: TI has discontinued the production of the device.

(2) Eco Plan - The planned eco-friendly classification: Pb-Free (RoHS), Pb-Free (RoHS Exempt), or Green (RoHS & no Sb/Br) - please check <http://www.ti.com/productcontent> for the latest availability information and additional product content details.

TBD: The Pb-Free/Green conversion plan has not been defined.

Pb-Free (RoHS): TI's terms "Lead-Free" or "Pb-Free" mean semiconductor products that are compatible with the current RoHS requirements for all 6 substances, including the requirement that lead not exceed 0.1% by weight in homogeneous materials. Where designed to be soldered at high temperatures, TI Pb-Free products are suitable for use in specified lead-free processes.

Pb-Free (RoHS Exempt): This component has a RoHS exemption for either 1) lead-based flip-chip solder bumps used between the die and package, or 2) lead-based die adhesive used between the die and leadframe. The component is otherwise considered Pb-Free (RoHS compatible) as defined above.

Green (RoHS & no Sb/Br): TI defines "Green" to mean Pb-Free (RoHS compatible), and free of Bromine (Br) and Antimony (Sb) based flame retardants (Br or Sb do not exceed 0.1% by weight in homogeneous material)

(3) MSL, Peak Temp. -- The Moisture Sensitivity Level rating according to the JEDEC industry standard classifications, and peak solder temperature.

(4) Multiple Top-Side Markings will be inside parentheses. Only one Top-Side Marking contained in parentheses and separated by a "~" will appear on a device. If a line is indented then it is a continuation of the previous line and the two combined represent the entire Top-Side Marking for that device.

Important Information and Disclaimer: The information provided on this page represents TI's knowledge and belief as of the date that it is provided. TI bases its knowledge and belief on information provided by third parties, and makes no representation or warranty as to the accuracy of such information. Efforts are underway to better integrate information from third parties. TI has taken and continues to take reasonable steps to provide representative and accurate information but may not have conducted destructive testing or chemical analysis on incoming materials and chemicals. TI and TI suppliers consider certain information to be proprietary, and thus CAS numbers and other limited information may not be available for release.

In no event shall TI's liability arising out of such information exceed the total purchase price of the TI part(s) at issue in this document sold by TI to Customer on an annual basis.

OTHER QUALIFIED VERSIONS OF TLV431A-Q1, TLV431B-Q1 :

- Catalog: [TLV431A](#), [TLV431B](#)

NOTE: Qualified Version Definitions:

- Catalog - TI's standard catalog product

TAPE AND REEL INFORMATION



QUADRANT ASSIGNMENTS FOR PIN 1 ORIENTATION IN TAPE



*All dimensions are nominal

Device	Package Type	Package Drawing	Pins	SPQ	Reel Diameter (mm)	Reel Width W1 (mm)	A0 (mm)	B0 (mm)	K0 (mm)	P1 (mm)	W (mm)	Pin1 Quadrant
TLV431AQDBVRQ1	SOT-23	DBV	5	3000	179.0	8.4	3.2	3.2	1.4	4.0	8.0	Q3
TLV431BQDBVRQ1	SOT-23	DBV	5	3000	179.0	8.4	3.2	3.2	1.4	4.0	8.0	Q3
TLV431BQDBZRQ1	SOT-23	DBZ	3	3000	179.0	8.4	3.15	2.95	1.22	4.0	8.0	Q3

TAPE AND REEL BOX DIMENSIONS

*All dimensions are nominal

Device	Package Type	Package Drawing	Pins	SPQ	Length (mm)	Width (mm)	Height (mm)
TLV431AQDBVRQ1	SOT-23	DBV	5	3000	203.0	203.0	35.0
TLV431BQDBVRQ1	SOT-23	DBV	5	3000	203.0	203.0	35.0
TLV431BQDBZRQ1	SOT-23	DBZ	3	3000	203.0	203.0	35.0

DBV (R-PDSO-G5)

PLASTIC SMALL-OUTLINE PACKAGE

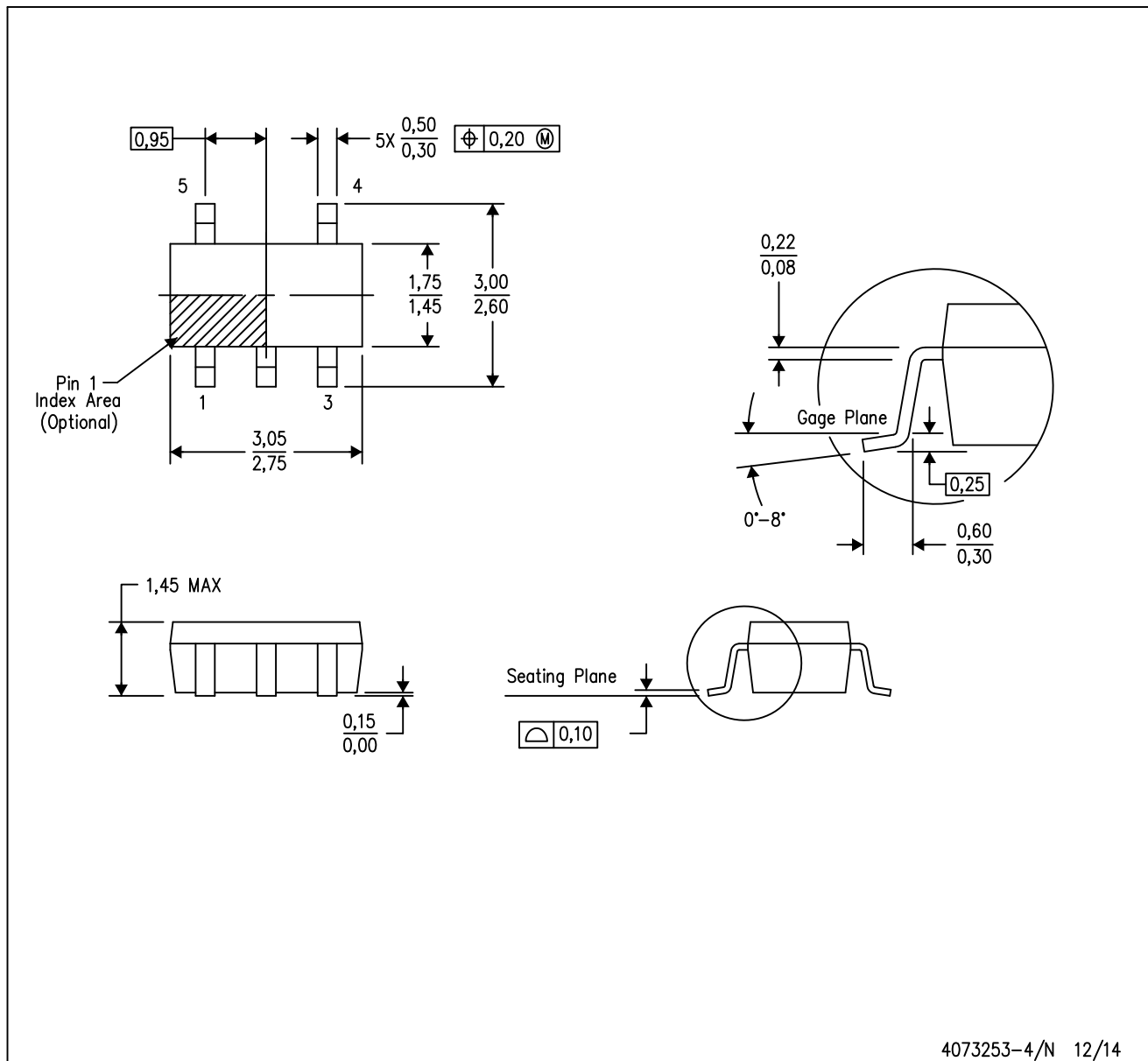

- NOTES:
- A. All linear dimensions are in millimeters.
 - B. This drawing is subject to change without notice.
 - C. Body dimensions do not include mold flash or protrusion. Mold flash and protrusion shall not exceed 0.15 per side.
 - D. Falls within JEDEC MO-178 Variation AA.

DBV (R-PDSO-G5)

PLASTIC SMALL OUTLINE



- NOTES:
- A. All linear dimensions are in millimeters.
 - B. This drawing is subject to change without notice.
 - C. Customers should place a note on the circuit board fabrication drawing not to alter the center solder mask defined pad.
 - D. Publication IPC-7351 is recommended for alternate designs.
 - E. Laser cutting apertures with trapezoidal walls and also rounding corners will offer better paste release. Customers should contact their board assembly site for stencil design recommendations. Example stencil design based on a 50% volumetric metal load solder paste. Refer to IPC-7525 for other stencil recommendations.

DBZ (R-PDSO-G3)

PLASTIC SMALL OUTLINE

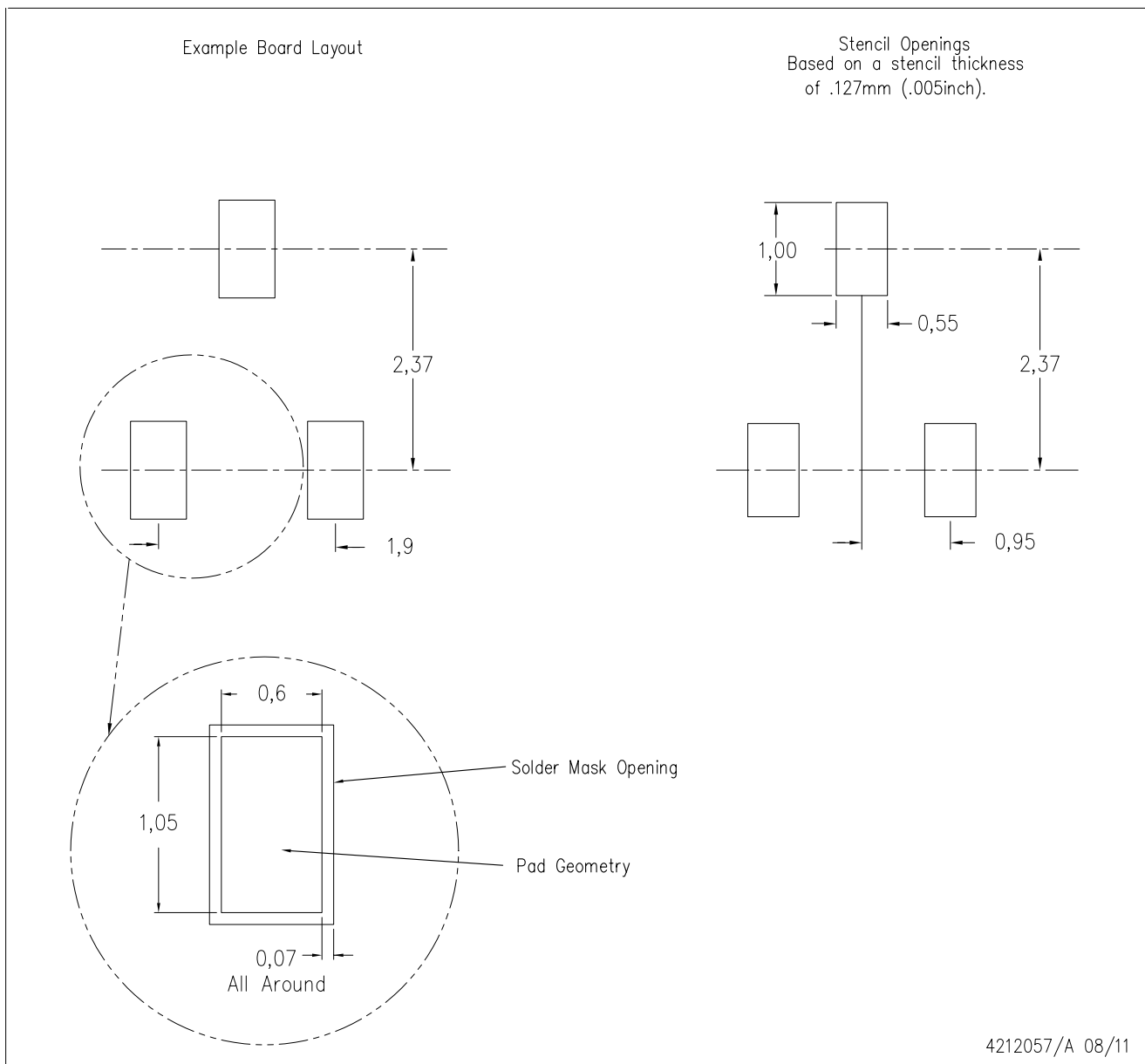

- NOTES:
- A. All linear dimensions are in millimeters.
 - B. This drawing is subject to change without notice.
 - C. Customers should place a note on the circuit board fabrication drawing not to alter the center solder mask defined pad.
 - D. Publication IPC-7351 is recommended for alternate designs.
 - E. Laser cutting apertures with trapezoidal walls and also rounding corners will offer better paste release. Customers should contact their board assembly site for stencil design recommendations. Example stencil design based on a 50% volumetric metal load solder paste. Refer to IPC-7525 for other stencil recommendations.

IMPORTANT NOTICE

Texas Instruments Incorporated and its subsidiaries (TI) reserve the right to make corrections, enhancements, improvements and other changes to its semiconductor products and services per JESD46, latest issue, and to discontinue any product or service per JESD48, latest issue. Buyers should obtain the latest relevant information before placing orders and should verify that such information is current and complete. All semiconductor products (also referred to herein as "components") are sold subject to TI's terms and conditions of sale supplied at the time of order acknowledgment.

TI warrants performance of its components to the specifications applicable at the time of sale, in accordance with the warranty in TI's terms and conditions of sale of semiconductor products. Testing and other quality control techniques are used to the extent TI deems necessary to support this warranty. Except where mandated by applicable law, testing of all parameters of each component is not necessarily performed.

TI assumes no liability for applications assistance or the design of Buyers' products. Buyers are responsible for their products and applications using TI components. To minimize the risks associated with Buyers' products and applications, Buyers should provide adequate design and operating safeguards.

TI does not warrant or represent that any license, either express or implied, is granted under any patent right, copyright, mask work right, or other intellectual property right relating to any combination, machine, or process in which TI components or services are used. Information published by TI regarding third-party products or services does not constitute a license to use such products or services or a warranty or endorsement thereof. Use of such information may require a license from a third party under the patents or other intellectual property of the third party, or a license from TI under the patents or other intellectual property of TI.

Reproduction of significant portions of TI information in TI data books or data sheets is permissible only if reproduction is without alteration and is accompanied by all associated warranties, conditions, limitations, and notices. TI is not responsible or liable for such altered documentation. Information of third parties may be subject to additional restrictions.

Resale of TI components or services with statements different from or beyond the parameters stated by TI for that component or service voids all express and any implied warranties for the associated TI component or service and is an unfair and deceptive business practice. TI is not responsible or liable for any such statements.

Buyer acknowledges and agrees that it is solely responsible for compliance with all legal, regulatory and safety-related requirements concerning its products, and any use of TI components in its applications, notwithstanding any applications-related information or support that may be provided by TI. Buyer represents and agrees that it has all the necessary expertise to create and implement safeguards which anticipate dangerous consequences of failures, monitor failures and their consequences, lessen the likelihood of failures that might cause harm and take appropriate remedial actions. Buyer will fully indemnify TI and its representatives against any damages arising out of the use of any TI components in safety-critical applications.

In some cases, TI components may be promoted specifically to facilitate safety-related applications. With such components, TI's goal is to help enable customers to design and create their own end-product solutions that meet applicable functional safety standards and requirements. Nonetheless, such components are subject to these terms.

No TI components are authorized for use in FDA Class III (or similar life-critical medical equipment) unless authorized officers of the parties have executed a special agreement specifically governing such use.

Only those TI components which TI has specifically designated as military grade or "enhanced plastic" are designed and intended for use in military/aerospace applications or environments. Buyer acknowledges and agrees that any military or aerospace use of TI components which have **not** been so designated is solely at the Buyer's risk, and that Buyer is solely responsible for compliance with all legal and regulatory requirements in connection with such use.

TI has specifically designated certain components as meeting ISO/TS16949 requirements, mainly for automotive use. In any case of use of non-designated products, TI will not be responsible for any failure to meet ISO/TS16949.

Products

Audio	www.ti.com/audio
Amplifiers	amplifier.ti.com
Data Converters	dataconverter.ti.com
DLP® Products	www.dlp.com
DSP	dsp.ti.com
Clocks and Timers	www.ti.com/clocks
Interface	interface.ti.com
Logic	logic.ti.com
Power Mgmt	power.ti.com
Microcontrollers	microcontroller.ti.com
RFID	www.ti-rfid.com
OMAP Applications Processors	www.ti.com/omap
Wireless Connectivity	www.ti.com/wirelessconnectivity

Applications

Automotive and Transportation	www.ti.com/automotive
Communications and Telecom	www.ti.com/communications
Computers and Peripherals	www.ti.com/computers
Consumer Electronics	www.ti.com/consumer-apps
Energy and Lighting	www.ti.com/energy
Industrial	www.ti.com/industrial
Medical	www.ti.com/medical
Security	www.ti.com/security
Space, Avionics and Defense	www.ti.com/space-avionics-defense
Video and Imaging	www.ti.com/video

TI E2E Community

e2e.ti.com