

- **High-Performance Floating-Point Digital Signal Processor (DSP)**
 - TMS320C30-50 (5 V)
40-ns Instruction Cycle Time
275 MOPS, 50 MFLOPS, 25 MIPS
 - TMS320C30-40 (5 V)
50-ns Instruction Cycle Time
220 MOPS, 40 MFLOPS, 20 MIPS
 - TMS320C30-33 (5 V)
60-ns Instruction Cycle Time
183.3 MOPS, 33.3 MFLOPS, 16.7 MIPS
 - TMS320C30-27 (5 V)
74-ns Instruction Cycle Time
148.5 MOPS, 27 MFLOPS, 13.5 MIPS
- 32-Bit High-Performance CPU
- 16-/32-Bit Integer and 32-/40-Bit Floating-Point Operations
- 32-Bit Instruction Word, 24-Bit Addresses
- Two 1K × 32-Bit Single-Cycle Dual-Access On-Chip RAM Blocks
- One 4K × 32-Bit Single-Cycle Dual-Access On-Chip ROM Block
- On-Chip Memory-Mapped Peripherals:
 - Two Serial Ports
 - Two 32-Bit Timers
 - One-Channel Direct Memory Access (DMA) Coprocessor for Concurrent I/O and CPU Operation
- Two 32-Bit External Ports
- 24- and 13-Bit Addresses
- 0.7- μ m Enhanced Performance Implanted CMOS (EPIC™) Technology
- 208-Pin Plastic Quad Flat Package (PPM Suffix)
- 181-Pin Grid Array Ceramic Package (GEL Suffix)
- Eight Extended-Precision Registers
- Two Address Generators With Eight Auxiliary Registers and Two Auxiliary Register Arithmetic Units (ARAUs)
- Two- and Three-Operand Instructions
- Parallel Arithmetic and Logic Unit (ALU) and Multiplier Execution in a Single Cycle
- Block-Repeat Capability
- Zero-Overhead Loops With Single-Cycle Branches
- Conditional Calls and Returns
- Interlocked Instructions for Multiprocessing Support
- Two Sets of Memory Strobes ($\overline{\text{STRB}}$ and $\overline{\text{MSTRB}}$) and One I/O Strobe ($\overline{\text{IOSTRB}}$)
- Separate Bus-Control Registers for Each Strobe-Control Wait-State Generation

description

The TMS320C30 is the newest member of the TMS320C3x generation of DSPs from Texas Instruments (TI™). The TMS320C30 is a 32-bit floating-point processor manufactured in 0.7- μ m triple-level-metal CMOS technology.

The TMS320C30's internal busing and special DSP instruction set have the speed and flexibility to execute up to 50 MFLOPS (million floating-point operations per second). The TMS320C30 optimizes speed by implementing functions in hardware that other processors implement through software or microcode. This hardware-intensive approach provides performance previously unavailable on a single chip.

The TMS320C30 can perform parallel multiply and ALU operations on integer or floating-point data in a single cycle. Each processor also possesses a general-purpose register file, a program cache, dedicated ARAUs, internal dual-access memories, one DMA channel supporting concurrent I/O, and a short machine-cycle time. High performance and ease of use are results of these features.

General-purpose applications are enhanced greatly by the large address space, multiprocessor interface, internally and externally generated wait states, two external interface ports, two timers, serial ports, and multiple interrupt structure. The TMS320C30 supports a wide variety of system applications from host processor to dedicated coprocessor.



Please be aware that an important notice concerning availability, standard warranty, and use in critical applications of Texas Instruments semiconductor products and disclaimers thereto appears at the end of this data sheet.

EPIC and TI are trademarks of Texas Instruments Incorporated.

PRODUCTION DATA information is current as of publication date. Products conform to specifications per the terms of Texas Instruments standard warranty. Production processing does not necessarily include testing of all parameters.



Copyright © 1997, Texas Instruments Incorporated

TMS320C30 DIGITAL SIGNAL PROCESSOR

SPRS032A – APRIL 1996 – REVISED JUNE 1997

description (continued)

High-level language support is implemented easily through a register-based architecture, large address space, powerful addressing modes, flexible instruction set, and well-supported floating-point arithmetic.

pinout and pin assignments

TMS320C30 GEL pinout and pin assignments

The TMS320C30 digital signal processor is available in a 181-pin grid array (PGA) package. The pinout of this package is shown in the following two illustrations. The pin assignments are listed in the TMS320C30 GEL pin assignments (alphabetical) table and the TMS320C30 GEL pin assignments (numerical) table.

	1	2	3	4	5	6	7	8	9	10	11	12	13	14	15	
A	H3 ()	D2 ()	D3 ()	D7 ()	D10 ()	D13 ()	D16 ()	D17 ()	D19 ()	D22 ()	D25 ()	D28 ()	XA0 ()	XA1 ()	XA5 ()	
B	X2/CLKIN ()	CVSS ()	H1 ()	D4 ()	D8 ()	D11 ()	D15 ()	D18 ()	D20 ()	D24 ()	D27 ()	D31 ()	XA4 ()	IVSS ()	XA6 ()	
C	EMU5 ()	X1 ()	DVSS ()	D0 ()	D5 ()	D9 ()	D14 ()	VSS ()	D21 ()	D26 ()	D30 ()	XA3 ()	DVSS ()	XA7 ()	XA10 ()	
D	XR \bar{W} ()	XR \bar{D} ()	VBBP ()	DDVDD ()	D1 ()	D6 ()	D12 ()	VDD ()	D23 ()	D29 ()	XA2 ()	ADVDD ()	XA9 ()	XA11 ()	MC \bar{M} P ()	
E	R \bar{D} ()	HOLDA ()	MSTRB ()	VSUBS ()	LOCATOR ()			DDVDD ()				XA8 ()	XA12 ()	EMU3 ()	EMU1 ()	
F	RESET ()	STRB ()	HOLD ()	IOSTRB ()								EMU4/ \bar{S} HZ ()	EMU2 ()	EMU0 ()	A0 ()	
G	\bar{I} ACK ()	XF0 ()	XF1 ()	R \bar{W} ()								A1 ()	A2 ()	A3 ()	A4 ()	
H	\bar{I} NT1 ()	\bar{I} NT0 ()	VSS ()	VDD ()	MDVDD ()			TMS320C30 Top View				ADVDD ()	VDD ()	VSS ()	A6 ()	A5 ()
J	\bar{I} NT2 ()	\bar{I} NT3 ()	RSV0 ()	RSV1 ()								A11 ()	A9 ()	A8 ()	A7 ()	
K	RSV2 ()	RSV3 ()	RSV5 ()	RSV7 ()								A17 ()	A14 ()	A12 ()	A10 ()	
L	RSV4 ()	RSV6 ()	RSV9 ()	CLKR1 ()				IODVDD ()				A22 ()	A18 ()	A15 ()	A13 ()	
M	RSV8 ()	RSV10 ()	FSR1 ()	PDVDD ()	CLKX0 ()	EMU6 ()	XD5 ()	VDD ()	XD16 ()	XD22 ()	XD27 ()	IODVDD ()	A21 ()	A19 ()	A16 ()	
N	DR1 ()	CLKX1 ()	DVSS ()	CLKR0 ()	TCLK1 ()	XD2 ()	XD7 ()	VSS ()	XD14 ()	XD19 ()	XD23 ()	XD28 ()	DVSS ()	A23 ()	A20 ()	
P	FSX1 ()	DX1 ()	FSR0 ()	TCLK0 ()	XD1 ()	XD4 ()	XD8 ()	XD10 ()	XD13 ()	XD17 ()	XD20 ()	XD24 ()	XD29 ()	CVSS ()	XD31 ()	
R	DR0 ()	FSX0 ()	DX0 ()	XD0 ()	XD3 ()	XD6 ()	XD9 ()	XD11 ()	XD12 ()	XD15 ()	XD18 ()	XD21 ()	XD25 ()	XD26 ()	XD30 ()	

TMS320C30 GEL Pinout (Top View)



TMS320C30 GEL pinout and pin assignments (continued)

15	14	13	12	11	10	9	8	7	6	5	4	3	2	1	
XA5	XA1	XA0	D28	D25	D22	D19	D17	D16	D13	D10	D7	D3	D2	H3	A
●	●	●	●	●	●	●	●	●	●	●	●	●	●	●	
XA6	IVSS	XA4	D31	D27	D24	D20	D18	D15	D11	D8	D4	H1	CVSS	X2/CLKIN	B
●	●	●	●	●	●	●	●	●	●	●	●	●	●	●	
XA10	XA7	DVSS	XA3	D30	D26	D21	VSS	D14	D9	D5	D0	DVSS	X1	EMU5	C
●	●	●	●	●	●	●	●	●	●	●	●	●	●	●	
MC/MP	XA11	XA9	ADVDD	XA2	D29	D23	VDD	D12	D6	D1	DDVDD	VBBP	XRDY	XRW	D
●	●	●	●	●	●	●	●	●	●	●	●	●	●	●	
EMU1	EMU3	XA12	XA8				DDVDD		LOCATOR	VSUBS	MSTRB	HOLDA	RDY		E
●	●	●	●				●		●	●	●	●	●	●	
A0	EMU0	EMU2	EMU4/SHZ								IOSTRB	HOLD	STRB	RESET	F
●	●	●	●								●	●	●	●	
A4	A3	A2	A1								R/W	XF1	XF0	IACK	G
●	●	●	●								●	●	●	●	
A5	A6	VSS	VDD	ADVDD						MDVDD	VDD	VSS	INT0	INT1	H
●	●	●	●	●						●	●	●	●	●	
A7	A8	A9	A11								RSV1	RSV0	INT3	INT2	J
●	●	●	●								●	●	●	●	
A10	A12	A14	A17								RSV7	RSV5	RSV3	RSV2	K
●	●	●	●								●	●	●	●	
A13	A15	A18	A22				IODVDD				CLKR1	RSV9	RSV6	RSV4	L
●	●	●	●				●				●	●	●	●	
A16	A19	A21	IODVDD	XD27	XD22	XD16	VDD	XD5	EMU6	CLKX0	PDVDD	FSR1	RSV10	RSV8	M
●	●	●	●	●	●	●	●	●	●	●	●	●	●	●	
A20	A23	DVSS	XD28	XD23	XD19	XD14	VSS	XD7	XD2	TCLK1	CLKR0	DVSS	CLKX1	DR1	N
●	●	●	●	●	●	●	●	●	●	●	●	●	●	●	
XD31	CVSS	XD29	XD24	XD20	XD17	XD13	XD10	XD8	XD4	XD1	TCLK0	FSR0	DX1	FSX1	P
●	●	●	●	●	●	●	●	●	●	●	●	●	●	●	
XD30	XD26	XD25	XD21	XD18	XD15	XD12	XD11	XD9	XD6	XD3	XD0	DX0	FSX0	DR0	R
●	●	●	●	●	●	●	●	●	●	●	●	●	●	●	

TMS320C30 GEL Pinout (Bottom View)

TMS320C30 DIGITAL SIGNAL PROCESSOR

SPRS032A – APRIL 1996 – REVISED JUNE 1997

TMS320C30 GEL Pin Assignments (Alphabetical)†

PIN		PIN		PIN		PIN		PIN	
NAME	NO.	NAME	NO.	NAME	NO.	NAME	NO.	NAME	NO.
A0	F15	D8	B5	EMU6	M6	VBBP	D3	XD15	R10
A1	G12	D9	C6	FSR0	P3	VDD	D8	XD16	M9
A2	G13	D10	A5	FSR1	M3	VDD	H4	XD17	P10
A3	G14	D11	B6	FSX0	R2	VDD	H12	XD18	R11
A4	G15	D12	D7	FSX1	P1	VDD	M8	XD19	N10
A5	H15	D13	A6	H1	B3	VSS	C8	XD20	P11
A6	H14	D14	C7	H3	A1	VSS	H3	XD21	R12
A7	J15	D15	B7	<u>HOLD</u>	F3	VSS	H13	XD22	M10
A8	J14	D16	A7	<u>HOLDA</u>	E2	VSS	N8	XD23	N11
A9	J13	D17	A8	<u>IACK</u>	G1	VSUBS	E4	XD24	P12
A10	K15	D18	B8	<u>INT0</u>	H2	X1	C2	XD25	R13
A11	J12	D19	A9	<u>INT1</u>	H1	X2/CLKIN	B1	XD26	R14
A12	K14	D20	B9	<u>INT2</u>	J1	XA0	A13	XD27	M11
A13	L15	D21	C9	<u>INT3</u>	J2	XA1	A14	XD28	N12
A14	K13	D22	A10	<u>IODV_{DD}</u>	L8	XA2	D11	XD29	P13
A15	L14	D23	D9	<u>IODV_{DD}</u>	M12	XA3	C12	XD30	R15
A16	M15	D24	B10	<u>IOSTRB</u>	F4	XA4	B13	XD31	P15
A17	K12	D25	A11	<u>IVSS</u>	B14	XA5	A15	XF0	G2
A18	L13	D26	C10	<u>LOCATOR</u>	E5	XA6	B15	<u>XF1</u>	G3
A19	M14	D27	B11	<u>MC/MP</u>	D15	XA7	C14	<u>XR_{DY}</u>	D2
A20	N15	D28	A12	<u>MDV_{DD}</u>	H5	XA8	E12	<u>XR_W</u>	D1
A21	M13	D29	D10	<u>MSTRB</u>	E3	XA9	D13		
A22	L12	D30	C11	<u>PDV_{DD}</u>	M4	XA10	C15		
A23	N14	D31	B12	<u>RDY</u>	E1	XA11	D14		
ADV _{DD}	D12	DDV _{DD}	D4	<u>RESET</u>	F1	XA12	E13		
ADV _{DD}	H11	DDV _{DD}	E8	RSV0	J3	XD0	R4		
CLKR0	N4	DR0	R1	RSV1	J4	XD1	P5		
CLKR1	L4	DR1	N1	RSV2	K1	XD2	N6		
CLKX0	M5	DVSS	C3	RSV3	K2	XD3	R5		
CLKX1	N2	DVSS	C13	RSV4	L1	XD4	P6		
CVSS	B2	DVSS	N3	RSV5	K3	XD5	M7		
CVSS	P14	DVSS	N13	RSV6	L2	XD6	R6		
D0	C4	DX0	R3	RSV7	K4	XD7	N7		
D1	D5	DX1	P2	RSV8	M1	XD8	P7		
D2	A2	EMU0	F14	RSV9	L3	XD9	R7		
D3	A3	EMU1	E15	RSV10	M2	XD10	P8		
D4	B4	EMU2	F13	<u>R_W</u>	G4	XD11	R8		
D5	C5	EMU3	E14	<u>STRB</u>	F2	XD12	R9		
D6	D6	EMU4/ <u>SHZ</u>	F12	TCLK0	P4	XD13	P9		
D7	A4	EMU5	C1	TCLK1	N5	XD14	N9		

† ADV_{DD}, CVSS, DDV_{DD}, DVSS, IODV_{DD}, IVSS, MDV_{DD}, PDV_{DD}, VDD, and VSS pins are on a common plane internal to the device.



TMS320C30 GEL Pin Assignments (Numerical)†

PIN		PIN		PIN		PIN		PIN	
NAME	NO.	NAME	NO.	NAME	NO.	NAME	NO.	NAME	NO.
H3	A1	D30	C11	XF1	G3	A13	L15	XD17	P10
D2	A2	XA3	C12	R/W	G4	RSV8	M1	XD20	P11
D3	A3	DV _{SS}	C13	A1	G12	RSV10	M2	XD24	P12
D7	A4	XA7	C14	A2	G13	FSR1	M3	XD29	P13
D10	A5	XA10	C15	A3	G14	PDV _{DD}	M4	CV _{SS}	P14
D13	A6	<u>XR/W</u>	D1	<u>A4</u>	G15	CLKX0	M5	XD31	P15
D16	A7	<u>XRDY</u>	D2	<u>INT1</u>	H1	EMU6	M6	DR0	R1
D17	A8	<u>VBBP</u>	D3	<u>INT0</u>	H2	XD5	M7	FSX0	R2
D19	A9	<u>DDV_{DD}</u>	D4	<u>V_{SS}</u>	H3	<u>V_{DD}</u>	M8	DX0	R3
D22	A10	D1	D5	<u>V_{DD}</u>	H4	XD16	M9	XD0	R4
D25	A11	D6	D6	MDV _{DD}	H5	XD22	M10	XD3	R5
D28	A12	D12	D7	ADV _{DD}	H11	XD27	M11	XD6	R6
XA0	A13	<u>V_{DD}</u>	D8	<u>V_{DD}</u>	H12	IODV _{DD}	M12	XD9	R7
XA1	A14	D23	D9	<u>V_{SS}</u>	H13	A21	M13	XD11	R8
XA5	A15	D29	D10	A6	H14	A19	M14	XD12	R9
X2/CLKIN	B1	XA2	D11	<u>A5</u>	H15	A16	M15	XD15	R10
CV _{SS}	B2	ADV _{DD}	D12	<u>INT2</u>	J1	DR1	N1	XD18	R11
H1	B3	XA9	D13	<u>INT3</u>	J2	CLKX1	N2	XD21	R12
D4	B4	<u>XA11</u>	D14	RSV0	J3	DV _{SS}	N3	XD25	R13
D8	B5	<u>MC/MP</u>	D15	RSV1	J4	CLKR0	N4	XD26	R14
D11	B6	<u>RDY</u>	E1	A11	J12	TCLK1	N5	XD30	R15
D15	B7	<u>HOLDA</u>	E2	A9	J13	XD2	N6		
D18	B8	<u>MSTRB</u>	E3	A8	J14	XD7	N7		
D20	B9	<u>V_{SUBS}</u>	E4	A7	J15	<u>V_{SS}</u>	N8		
D24	B10	LOCATOR	E5	RSV2	K1	XD14	N9		
D27	B11	DDV _{DD}	E8	RSV3	K2	XD19	N10		
D31	B12	XA8	E12	RSV5	K3	XD23	N11		
XA4	B13	XA12	E13	RSV7	K4	XD28	N12		
IV _{SS}	B14	EMU3	E14	A17	K12	DV _{SS}	N13		
XA6	B15	EMU1	E15	A14	K13	A23	N14		
EMU5	C1	<u>RESET</u>	F1	A12	K14	A20	N15		
X1	C2	<u>STRB</u>	F2	A10	K15	FSX1	P1		
DV _{SS}	C3	<u>HOLD</u>	F3	RSV4	L1	DX1	P2		
D0	C4	<u>IOSTRB</u>	F4	RSV6	L2	FSR0	P3		
D5	C5	<u>EMU4/SHZ</u>	F12	RSV9	L3	TCLK0	P4		
D9	C6	EMU2	F13	CLKR1	L4	XD1	P5		
D14	C7	EMU0	F14	IODV _{DD}	L8	XD4	P6		
V _{SS}	C8	<u>A0</u>	F15	A22	L12	XD8	P7		
D21	C9	<u>IACK</u>	G1	A18	L13	XD10	P8		
D26	C10	XF0	G2	A15	L14	XD13	P9		

† ADV_{DD}, CV_{SS}, DDV_{DD}, DV_{SS}, IODV_{DD}, IV_{SS}, MDV_{DD}, PDV_{DD}, V_{DD}, and V_{SS} pins are on a common plane internal to the device.

TMS320C30 DIGITAL SIGNAL PROCESSOR

SPRS032A – APRIL 1996 – REVISED JUNE 1997

TMS320C30 PPM pinout and pin assignments

The TMS320C30 PPM device is packaged in a 208-pin plastic quad flatpack (PQFP) JEDEC standard package. The following illustration shows the pinout for this package. The pin assignments are listed in the TMS320C30 PPM pin assignments (alphabetical) table and the TMS320C30 PPM pin assignments (numerical) table.

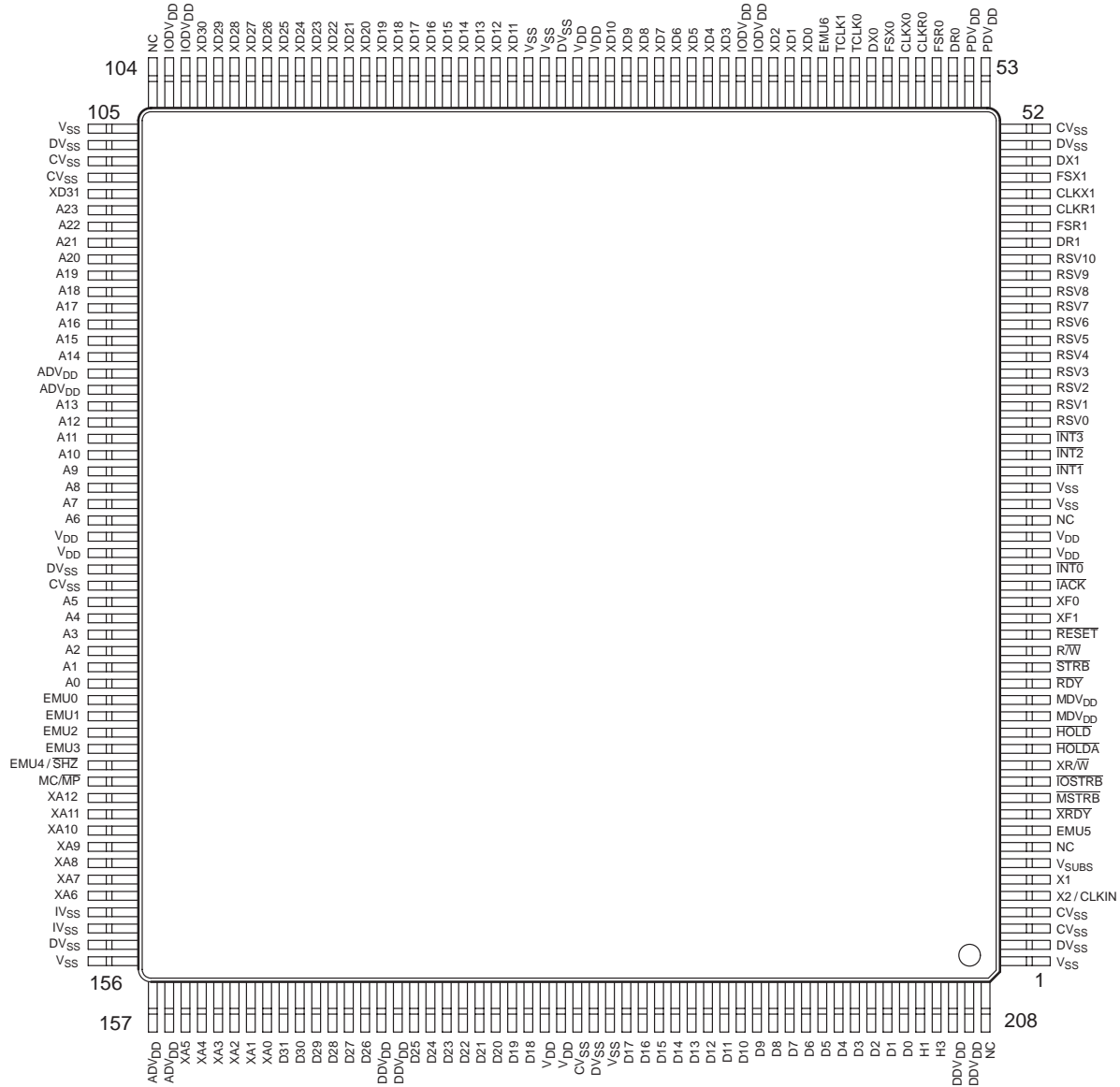

TMS320C30 PPM Pinout



TMS320C30 PPM Pin Assignments (Alphabetical)†

PIN		PIN		PIN		PIN		PIN		PIN	
NAME	NO.	NAME	NO.	NAME	NO.	NAME	NO.	NAME	NO.	NAME	NO.
A0	139	CVSS	107	D31	165	$\overline{\text{INT2}}$	32	TCLK1	62	XD2	66
A1	138	CVSS	108	DDVDD	171	$\overline{\text{INT3}}$	33	VDD	26	XD3	69
A2	137	CVSS	133	DDVDD	172	IODVDD	67	VDD	27	XD4	70
A3	136	CVSS	183	DDVDD	206	IODVDD	68	VDD	77	XD5	71
A4	135	D0	203	DDVDD	207	IODVDD	102	VDD	78	XD6	72
A5	134	D1	202	DR0	55	IODVDD	103	VDD	130	XD7	73
A6	129	D2	201	DR1	45	$\overline{\text{IOSTRB}}$	12	VDD	131	XD8	74
A7	128	D3	200	DVSS	2	IVSS	153	VDD	181	XD9	75
A8	127	D4	199	DVSS	51	IVSS	154	VDD	182	XD10	76
A9	126	D5	198	DVSS	105	MC/MP	145	VSS	1	XD11	82
A10	125	D6	197	DVSS	106	MDVDD	16	VSS	29	XD12	83
A11	124	D7	196	DVSS	132	MDVDD	17	VSS	30	XD13	84
A12	123	D8	195	DVSS	155	$\overline{\text{MSTRB}}$	11	VSS	80	XD14	85
A13	122	D9	194	DVSS	156	NC	8	VSS	81	XD15	86
A14	119	D10	193	DVSS	184	NC	28	VSS	105	XD16	87
A15	118	D11	192	DX0	60	NC	104	VSS	156	XD17	88
A16	117	D12	191	DX1	50	NC	208	VSS	185	XD18	89
A17	116	D13	190	EMU0	140	PDVDD	53	VSUBS	7	XD19	90
A18	115	D14	189	EMU1	141	PDVDD	54	X1	6	XD20	91
A19	114	D15	188	EMU2	142	$\overline{\text{RDY}}$	18	X2/CLKIN	5	XD21	92
A20	113	D16	187	EMU3	143	$\overline{\text{RESET}}$	21	XA0	164	XD22	93
A21	112	D17	186	EMU4/SHZ	144	RSV0	34	XA1	163	XD23	94
A22	111	D18	180	EMU5	9	RSV1	35	XA2	162	XD24	95
A23	110	D19	179	EMU6	63	RSV2	36	XA3	161	XD25	96
ADVDD	120	D20	178	FSR0	56	RSV3	37	XA4	160	XD26	97
ADVDD	121	D21	177	FSR1	46	RSV4	38	XA5	159	XD27	98
ADVDD	157	D22	176	FSX0	59	RSV5	39	XA6	152	XD28	99
ADVDD	158	D23	175	FSX1	49	RSV6	40	XA7	151	XD29	100
CLKR0	57	D24	174	H1	204	RSV7	41	XA8	150	XD30	101
CLKR1	47	D25	173	H3	205	RSV8	42	XA9	148	XD31	109
CLKX0	58	D26	170	$\overline{\text{HOLD}}$	15	RSV9	43	XA10	149	XF0	23
CLKX1	48	D27	169	$\overline{\text{HOLDA}}$	14	RSV10	44	XA11	147	XF1	22
CVSS	3	D28	168	$\overline{\text{IACK}}$	24	R/W	20	XA12	146	$\overline{\text{XRDY}}$	10
CVSS	4	D29	167	$\overline{\text{INT0}}$	25	$\overline{\text{STRB}}$	19	XD0	64	$\overline{\text{XR/W}}$	13
CVSS	52	D30	166	$\overline{\text{INT1}}$	31	TCLK0	61	XD1	65		

† ADVDD, CVSS, DDVDD, DVSS, IODVDD, IVSS, MDVDD, PDVDD, VDD, and VSS pins are on a common plane internal to the device.

TMS320C30 DIGITAL SIGNAL PROCESSOR

SPRS032A – APRIL 1996 – REVISED JUNE 1997

TMS320C30 PPM Pin Assignments (Numerical)†

NO.	PIN NAME	NO.	PIN NAME	NO.	PIN NAME	NO.	PIN NAME	NO.	PIN NAME
1	V _{SS}	43	RSV9	85	XD14	127	A8	169	D27
2	DV _{SS}	44	RSV10	86	XD15	128	A7	170	D26
3	CV _{SS}	45	DR1	87	XD16	129	A6	171	DDV _{DD}
4	CV _{SS}	46	FSR1	88	XD17	130	V _{DD}	172	DDV _{DD}
5	X2/CLKIN	47	CLKR1	89	XD18	131	V _{DD}	173	D25
6	X1	48	CLKX1	90	XD19	132	DV _{SS}	174	D24
7	V _{SUBS}	49	FSX1	91	XD20	133	CV _{SS}	175	D23
8	NC	50	DX1	92	XD21	134	A5	176	D22
9	EMU5	51	DV _{SS}	93	XD22	135	A4	177	D21
10	XRDY	52	CV _{SS}	94	XD23	136	A3	178	D20
11	MSTRB	53	PDV _{DD}	95	XD24	137	A2	179	D19
12	IOSTRB	54	PDV _{DD}	96	XD25	138	A1	180	D18
13	XR/W	55	DR0	97	XD26	139	A0	181	V _{DD}
14	HOLDA	56	FSR0	98	XD27	140	EMU0	182	V _{DD}
15	HOLD	57	CLKR0	99	XD28	141	EMU1	183	CV _{SS}
16	MDV _{DD}	58	CLKX0	100	XD29	142	EMU2	184	DV _{SS}
17	MDV _{DD}	59	FSX0	101	XD30	143	EMU3	185	V _{SS}
18	RDY	60	DX0	102	IODV _{DD}	144	EMU4/SHZ	186	D17
19	STRB	61	TCLK0	103	IODV _{DD}	145	MC/MP	187	D16
20	R/W	62	TCLK1	104	NC	146	XA12	188	D15
21	RESET	63	EMU6	105	V _{SS}	147	XA11	189	D14
22	XF1	64	XD0	106	DV _{SS}	148	XA10	190	D13
23	XF0	65	XD1	107	CV _{SS}	149	XA9	191	D12
24	IACK	66	XD2	108	CV _{SS}	150	XA8	192	D11
25	INT0	67	IODV _{DD}	109	XD31	151	XA7	193	D10
26	V _{DD}	68	IODV _{DD}	110	A23	152	XA6	194	D9
27	V _{DD}	69	XD3	111	A22	153	IV _{SS}	195	D8
28	NC	70	XD4	112	A21	154	IV _{SS}	196	D7
29	V _{SS}	71	XD5	113	A20	155	DV _{SS}	197	D6
30	V _{SS}	72	XD6	114	A19	156	V _{SS}	198	D5
31	INT1	73	XD7	115	A18	157	ADV _{DD}	199	D4
32	INT2	74	XD8	116	A17	158	ADV _{DD}	200	D3
33	INT3	75	XD9	117	A16	159	XA5	201	D2
34	RSV0	76	XD10	118	A15	160	XA4	202	D1
35	RSV1	77	V _{DD}	119	A14	161	XA3	203	D0
36	RSV2	78	V _{DD}	120	ADV _{DD}	162	XA2	204	H1
37	RSV3	79	DV _{SS}	121	ADV _{DD}	163	XA1	205	H3
38	RSV4	80	V _{SS}	122	A13	164	XA0	206	DDV _{DD}
39	RSV5	81	V _{SS}	123	A12	165	D31	207	DDV _{DD}
40	RSV6	82	XD11	124	A11	166	D30	208	NC
41	RSV7	83	XD12	125	A10	167	D29		
42	RSV8	84	XD13	126	A9	168	D28		

† ADV_{DD}, CV_{SS}, DDV_{DD}, DV_{SS}, IODV_{DD}, IV_{SS}, MDV_{DD}, PDV_{DD}, V_{DD}, and V_{SS} pins are on a common plane internal to the device.



POST OFFICE BOX 1443 • HOUSTON, TEXAS 77251-1443

pin functions

This section provides signal descriptions for the TMS320C30 in the microprocessor mode. The following tables list each signal, the number of pins, type of operating mode(s) (that is, input, output, or high-impedance state as indicated by I, O, or Z), and a brief description of its function. All pins labeled NC have special functions and should not be connected by the user. A line over a signal name (for example, $\overline{\text{RESET}}$) indicates that the signal is active low (true at logic 0 level). The signals are grouped according to function.

TMS320C30 Pin Functions

PIN NAME	QTY‡	TYPE†	DESCRIPTION	CONDITIONS WHEN SIGNAL IS Z TYPE§
PRIMARY BUS INTERFACE				
D31–D0	32	I/O/Z	32-bit data port of the primary bus interface	S H R
A23–A0	24	O/Z	24-bit address port of the primary bus interface	S H R
$\overline{\text{R/W}}$	1	O/Z	Read/write for primary bus interface. $\overline{\text{R/W}}$ is high when a read is performed and low when a write is performed over the parallel interface.	S H R
$\overline{\text{STRB}}$	1	O/Z	External access strobe for the primary bus interface	S H
$\overline{\text{RDY}}$	1	I	Ready. $\overline{\text{RDY}}$ indicates that the external device is prepared for a primary-bus-interface transaction to complete.	
$\overline{\text{HOLD}}$	1	I	Hold for primary bus interface. When $\overline{\text{HOLD}}$ is a logic low, any ongoing transaction is completed. A23–A0, D31–D0, $\overline{\text{STRB}}$, and $\overline{\text{R/W}}$ are in the high-impedance state and all transactions over the primary bus interface are held until $\overline{\text{HOLD}}$ becomes a logic high or the NOHOLD bit of the primary-bus-control register is set.	
$\overline{\text{HOLDA}}$	1	O/Z	Hold acknowledge for primary bus interface. $\overline{\text{HOLDA}}$ is generated in response to a logic low on $\overline{\text{HOLD}}$. $\overline{\text{HOLDA}}$ indicates that A23–A0, D31–D0, $\overline{\text{STRB}}$, and $\overline{\text{R/W}}$ are in the high-impedance state and that all transactions over the bus are held. $\overline{\text{HOLDA}}$ is high in response to a logic high of $\overline{\text{HOLD}}$ or when the NOHOLD bit of the primary-bus-control register is set.	S
EXPANSION BUS INTERFACE				
XD31–XD0	32	I/O/Z	32-bit data port of the expansion bus interface	S R
XA12–XA0	13	O/Z	13-bit address port of the expansion bus interface	S R
$\overline{\text{XR/W}}$	1	O/Z	Read/write signal for expansion bus interface. When a read is performed, $\overline{\text{XR/W}}$ is held high; when a write is performed, $\overline{\text{XR/W}}$ is low.	S R
$\overline{\text{MSTRB}}$	1	O/Z	External memory access strobe for the expansion bus interface	S
$\overline{\text{IOSTRB}}$	1	O/Z	External I/O access strobe for the expansion bus interface	S
$\overline{\text{XRDY}}$	1	I	Ready signal. $\overline{\text{XRDY}}$ indicates that the external device is prepared for an expansion-bus-interface transaction to complete.	
CONTROL SIGNALS				
$\overline{\text{RESET}}$	1	I	Reset. When $\overline{\text{RESET}}$ is a logic low, the device is in the reset condition. When $\overline{\text{RESET}}$ becomes a logic high, execution begins from the location specified by the reset vector.	
$\overline{\text{INT3}}\text{--}\overline{\text{INT0}}$	4	I	External interrupts	
$\overline{\text{IACK}}$	1	O/Z	Interrupt acknowledge. $\overline{\text{IACK}}$ is generated by the IACK instruction. $\overline{\text{IACK}}$ can be used to indicate the beginning or end of an interrupt-service routine.	S
$\overline{\text{MC/MP}}$	1	I	Microcomputer/microprocessor mode	
XF1, XF0	2	I/O/Z	External flags. XF1 and XF0 are used as general-purpose I/Os or to support interlocked processor instructions.	S R

† I = input, O = output, Z = high-impedance state. All pins labeled NC have specified functions and should not be connected by the user.

‡ Quantity is the same for GEL and PPM packages unless otherwise noted.

§ S = SHZ active, H = HOLD active, R = RESET active

TMS320C30 DIGITAL SIGNAL PROCESSOR

SPRS032A – APRIL 1996 – REVISED JUNE 1997

TMS320C30 Pin Functions (Continued)

NAME	PIN		TYPE†	DESCRIPTION	CONDITIONS WHEN SIGNAL IS Z TYPE§	
	QTY‡				S	R
SERIAL PORT 0 SIGNALS						
CLKX0	1		I/O/Z	Serial port 0 transmit clock. CLKX0 is the serial shift clock for the serial port 0 transmitter.	S	R
DX0	1		I/O/Z	Data transmit output. Serial port 0 transmits serial data on DX0.	S	R
FSX0	1		I/O/Z	Frame synchronization pulse for transmit. The FSX0 pulse initiates the transmit data process over DX0.	S	R
CLKR0	1		I/O/Z	Serial port 0 receive clock. CLKR0 is the serial shift clock for the serial port 0 receiver.	S	R
DR0	1		I/O/Z	Data receive. Serial port 0 receives serial data on DR0.	S	R
FSR0	1		I/O/Z	Frame synchronization pulse for receive. The FSR0 pulse initiates the receive data process over DR0.	S	R
SERIAL PORT 1 SIGNALS						
CLKX1	1		I/O/Z	Serial port 1 transmit clock. CLKX1 is the serial shift clock for the serial port 1 transmitter.	S	R
DX1	1		I/O/Z	Data transmit output. Serial port 1 transmits serial data on DX1.	S	R
FSX1	1		I/O/Z	Frame synchronization pulse for transmit. The FSX1 pulse initiates the transmit data process over DX1.	S	R
CLKR1	1		I/O/Z	Serial port 1 receive clock. CLKR1 is the serial shift clock for the serial port 1 receiver.	S	R
DR1	1		I/O/Z	Data receive. Serial port 1 receives serial data on DR1.	S	R
FSR1	1		I/O/Z	Frame synchronization pulse for receive. The FSR1 pulse initiates the receive data process over DR1.	S	R
TIMER 0 SIGNAL						
TCLK0	1		I/O/Z	Timer clock 0. As an input, TCLK0 is used by timer 0 to count external pulses. As an output, TCLK0 outputs pulses generated by timer 0.	S	R
TIMER 1 SIGNAL						
TCLK1	1		I/O/Z	Timer clock 1. As an input, TCLK1 is used by timer 1 to count external pulses. As an output, TCLK1 outputs pulses generated by timer 1.	S	R
SUPPLY AND OSCILLATOR SIGNALS						
	GEL	PPM				
VDD	4	8	I	5 V supply¶		
IODVDD	2	4	I	5 V supply¶		
ADVDD	2	4	I	5 V supply¶		
PDVDD	1	2	I	5 V supply¶		
DDVDD	2	4	I	5 V supply¶		
MDVDD	1	2	I	5 V supply¶		
VSS	4	8	I	Ground		
DVSS	4	8	I	Ground		
CVSS	2	4	I	Ground		
IVSS	2	1	I	Ground		

† I = input, O = output, Z = high-impedance state. All pins labeled NC have special functions and should not be connected by the user.

‡ Quantity is the same for GEL and PPM packages unless otherwise noted.

§ S = SHZ active, H = HOLD active, R = RESET active

¶ Recommended decoupling capacitor is 0.1 μ F.



TMS320C30 Pin Functions (Continued)

NAME	PIN QTY‡	TYPE†	DESCRIPTION	CONDITIONS WHEN SIGNAL IS Z TYPE§
SUPPLY AND OSCILLATOR SIGNALS (CONTINUED)				
V _{BBP}	1	NC	V _{BB} pump oscillator output	
V _{SUBS}	1	I	Substrate terminal. Tie to ground.	
X1	1	O	Output from the internal oscillator for the crystal. If a crystal is not used, X1 should be left unconnected.	
X2/CLKIN	1	I	Input to the internal oscillator from the crystal or a clock	
H1	1	O/Z	External H1 clock. H1 has a period equal to twice CLKIN.	S
H3	1	O/Z	External H3 clock. H3 has a period equal to twice CLKIN.	S
RESERVED¶				
EMU0–EMU2	3	I	Reserved. Use pullup resistors to 5 V.	
EMU3	1	O/Z	Reserved	S
EMU4/ $\overline{\text{SHZ}}$	1	I	Shutdown high impedance. When active, EMU4/ $\overline{\text{SHZ}}$ shuts down the TMS320C30 and places all pins in the high-impedance state. EMU4/ $\overline{\text{SHZ}}$ is used for board-level testing to ensure that no dual-drive conditions occur. CAUTION: A low on $\overline{\text{SHZ}}$ corrupts TMS320C30 memory and register contents. Reset the device with $\overline{\text{SHZ}}$ high to restore it to a known operating condition.	
EMU5, EMU6	2	NC	Reserved	
RSV10–RSV5	6	I/O	Reserved. Use pullup resistors to 5 V.	
RSV4–RSV0	5	I	Reserved. Tie pins directly to 5 V.	
Locator	1#	NC	Reserved	

† I = input, O = output, Z = high-impedance state. All pins labeled NC have special functions and should not be connected by the user.

‡ Quantity is the same for GEL and PPM packages unless otherwise noted.

§ S = $\overline{\text{SHZ}}$ active, H = $\overline{\text{HOLD}}$ active, R = $\overline{\text{RESET}}$ active

¶ Follow the connections specified for the reserved pins. Use 18-k Ω –22-k Ω pullup resistors for best results. All 5-V supply pins must be connected to a common supply plane, and all ground pins must be connected to a common ground plane.

For the GEL package only. There is no locator in the PPM package.

TMS320C30 DIGITAL SIGNAL PROCESSOR

SPRS032A – APRIL 1996 – REVISED JUNE 1997

functional block diagram

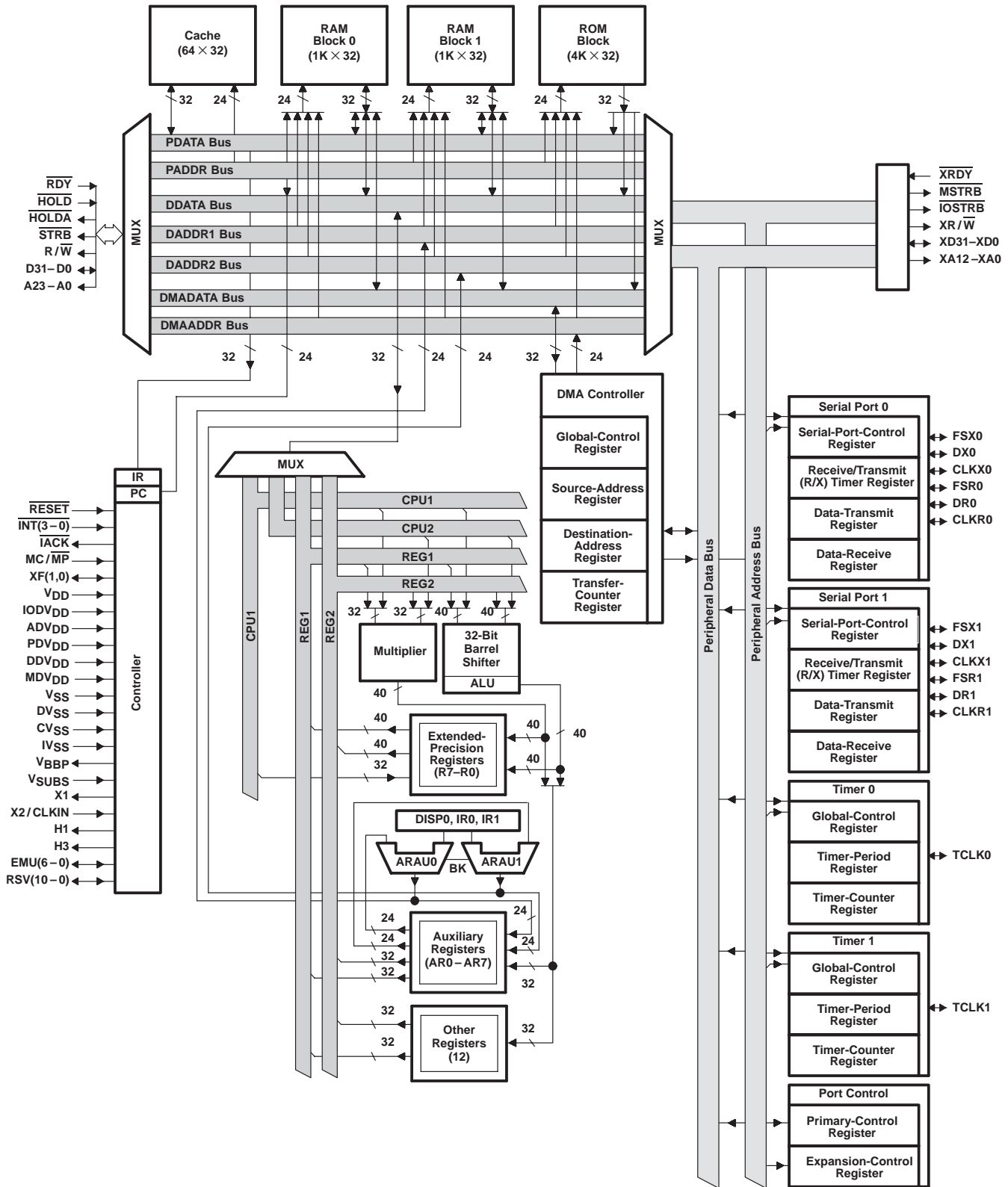

memory map

Figure 1 depicts the memory map for the TMS320C30. Refer to the *TMS320C3x User's Guide* (literature number SPRU031) for a detailed description of this memory mapping. Figure 2 shows the reset, interrupt, and trap vector/branches memory-map locations. Figure 3 shows the peripheral bus memory-mapped registers.

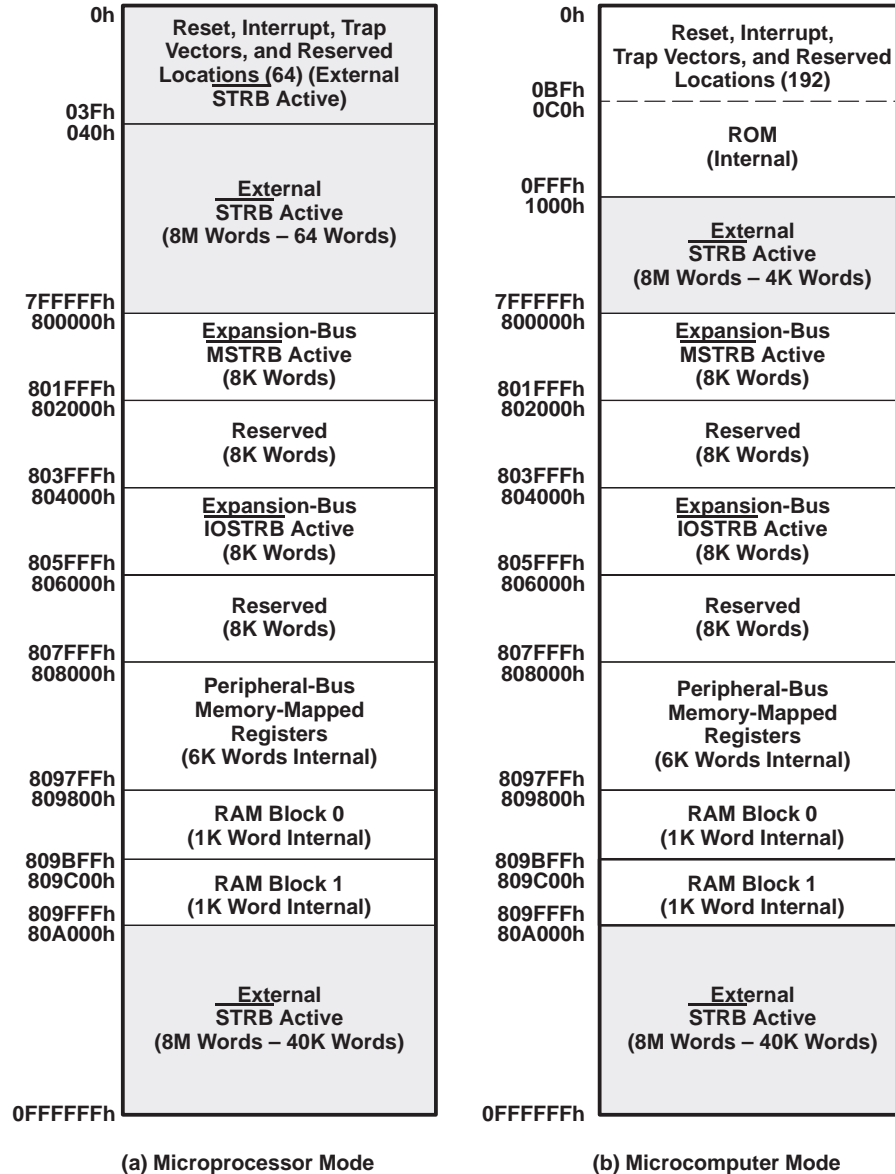

Figure 1. TMS320C30 Memory Map

TMS320C30 DIGITAL SIGNAL PROCESSOR

SPRS032A – APRIL 1996 – REVISED JUNE 1997

memory map (continued)

00h	Reset
01h	$\overline{\text{INT0}}$
02h	$\overline{\text{INT1}}$
03h	$\overline{\text{INT2}}$
04h	$\overline{\text{INT3}}$
05h	XINT0
06h	RINT0
07h	XINT1
08h	RINT1
09h	TINT0
0Ah	TINT1
0Bh	DINT
0Ch	Reserved
1Fh	
20h	
	TRAP 0
	.
	.
	.
3Bh	TRAP 27
3Ch	Reserved
3Fh	

(a) Microprocessor Mode

00h	Reset
01h	$\overline{\text{INT0}}$
02h	$\overline{\text{INT1}}$
03h	$\overline{\text{INT2}}$
04h	$\overline{\text{INT3}}$
05h	XINT0
06h	RINT0
07h	XINT1
08h	RINT1
09h	TINT0
0Ah	TINT1
0Bh	DINT
0Ch	Reserved
1Fh	
20h	
	TRAP 0
	.
	.
	.
3Bh	TRAP 27
3Ch	Reserved
BFh	

(a) Microcomputer Mode

Figure 2. Reset, Interrupt, and Trap Vector/Branches Memory-Map Locations

memory map (continued)

808000h	DMA Global Control
808004h	DMA Source Address
808006h	DMA Destination Address
808008h	DMA Transfer Counter
808020h	Timer 0 Global Control
808024h	Timer 0 Counter
808028h	Timer 0 Period
808030h	Timer 1 Global Control
808034h	Timer 1 Counter
808038h	Timer 1 Period Register
808040h	Serial Port 0 Global Control
808042h	FSX/DX/CLKX Serial Port 0 Control
808043h	FSR/DR/CLKR Serial Port 0 Control
808044h	Serial Port 0 R/X Timer Control
808045h	Serial Port 0 R/X Timer Counter
808046h	Serial Port 0 R/X Timer Period
808048h	Serial Port 0 Data Transmit
80804Ch	Serial Port 0 Data Receive
808050h	Serial Port 1 Global Control
808052h	FSX/DX/CLKX Serial Port 1 Control
808053h	FSR/DR/CLKR Serial Port 1 Control
808054h	Serial Port 1 R/X Timer Control
808055h	Serial Port 1 R/X Timer Counter
808056h	Serial Port 1 R/X Timer Period
808058h	Serial Port 1 Data Transmit
80805Ch	Serial Port 1 Data Receive
808060h	Expansion-Bus Control
808064h	Primary-Bus Control

†Shading denotes reserved address locations

Figure 3. Peripheral Bus Memory-Mapped Registers†

TMS320C30 DIGITAL SIGNAL PROCESSOR

SPRS032A – APRIL 1996 – REVISED JUNE 1997

absolute maximum ratings over specified temperature range (unless otherwise noted)[†]

Supply voltage range, V_{CC} (see Note 1)	–0.3 V to 7 V
Input voltage range, V_I	–0.3 V to 7 V
Output voltage range, V_O	–0.3 V to 7 V
Continuous power dissipation (see Note 2)	3.15 W
Operating case temperature range, T_C	0°C to 85°C
Storage temperature range, T_{stg}	–55°C to 150°C

[†] Stresses beyond those listed under “absolute maximum ratings” may cause permanent damage to the device. These are stress ratings only, and functional operation of the device at these or any other conditions beyond those indicated under “recommended operating conditions” is not implied. Exposure to absolute-maximum-rated conditions for extended periods may affect device reliability.

NOTES: 1. All voltage values are with respect to V_{SS} .

2. Actual operating power is less. This value is obtained under specially produced worst-case test conditions, which are not sustained during normal device operation. These conditions consist of continuous parallel writes of a checkerboard pattern to both primary and extension buses at the maximum rate possible. See normal (I_{CC}) current specification in the electrical characteristics table and also read *Calculation of TMS320C30 Power Dissipation Application Report* (literature number SPRA020).

recommended operating conditions (see Note 3)

		MIN	NOM [‡]	MAX	UNIT
V_{DD}	Supply voltage (AV_{DD} , etc.)	4.75	5	5.25	V
V_{SS}	Supply voltage (CV_{SS} , etc.)		0		V
V_{IH}	High-level input voltage	All other pins	2	$V_{DD} + 0.3$ [§]	V
		CLKIN	2.6	$V_{DD} + 0.3$ [§]	
V_{IL}	Low-level input voltage	–0.3 [§]		0.8	V
I_{OH}	High-level output current			–300	μA
I_{OL}	Low-level output current			2	mA
T_C	Operating case temperature	0		85	°C

[‡] All nominal values are at $V_{DD} = 5$ V, T_A (ambient air temperature) = 25°C.

[§] These values are derived from characterization and not tested.

NOTE 3: All input and output voltage levels are TTL-compatible.



**electrical characteristics over recommended ranges of supply voltage (unless otherwise noted)
(see Note 3)**

PARAMETER		TEST CONDITIONS†	MIN	TYP‡	MAX	UNIT
V _{OH}	High-level output voltage	V _{DD} = MIN, I _{OH} = MAX	2.4	3		V
V _{OL}	Low-level output voltage	V _{DD} = MIN, I _{OL} = MAX		0.3	0.6§	V
I _Z	High-impedance current	V _{DD} = MAX	- 20		20	μA
I _I	Input current	V _I = V _{SS} to V _{DD}	- 10		10	μA
I _{IP}	Input current	Inputs with internal pullups (see Note 4)	- 600		20	μA
I _{CC}	Supply current	T _A = 25°C, V _{DD} = MAX, t _c (CI) = MIN, See Note 5	'320C30-27	130	600	mA
			'320C30-33	150	600	
			'320C30-40	175	600	
			'320C30-50	200	600	
C _i	Input capacitance	CLKIN			25	pF
		All other inputs			15	
C _O	Output capacitance				20¶	pF

† For conditions shown as MIN/MAX, use the appropriate value specified in recommended operating conditions.

‡ All typical values are at V_{DD} = 5 V, T_A (ambient air temperature) = 25°C.

§ These values are derived from characterization but not tested.

¶ These values are derived by design but not tested.

- NOTES:
3. All input and output voltage levels are TTL-compatible.
 4. Pins with internal pullup devices: INT0–INT3, MC/MP, RSV0–RSV10. Although RSV0–RSV10 have internal pullup devices, external pullups should be used on each pin as identified in the pin functions tables.
 5. Actual operating current is less than this maximum value. This value is obtained under specially produced worst-case test conditions, which are not sustained during normal device operation. These conditions consist of continuous parallel writes of a checkerboard pattern to both primary and expansion buses at the maximum rate possible. See *Calculation of TMS320C30 Power Dissipation Application Report* (literature number SPRA020).

PARAMETER MEASUREMENT INFORMATION

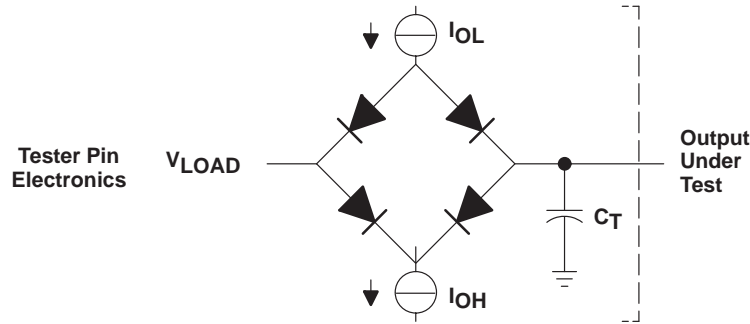

Where: I_{OL} = 2 mA (all outputs)
 I_{OH} = 300 μ A (all outputs)
 V_{LOAD} = 2.15 V
 C_T = 80-pF typical load-circuit capacitance

Figure 4. Test Load Circuit

signal transition levels

TTL-level outputs are driven to a minimum logic-high level of 2.4 V and to a maximum logic-low level of 0.6 V. Output transition times are specified as follows (see Figure 5):

- For a high-to-low transition on a TTL-compatible output signal, the level at which the output is said to be no longer high is 2 V and the level at which the output is said to be low is 1 V.
- For a low-to-high transition, the level at which the output is said to be no longer low is 1 V and the level at which the output is said to be high is 2 V.

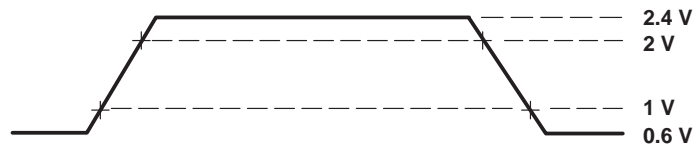

Figure 5. TTL-Level Outputs

Transition times for TTL-compatible inputs are specified as follows (see Figure 6):

- For a high-to-low transition on an input signal, the level at which the input is said to be no longer high is 2 V and the level at which the input is said to be low is 0.8 V.
- For a low-to-high transition on an input signal, the level at which the input is said to be no longer low is 0.8 V and the level at which the input is said to be high is 2 V.

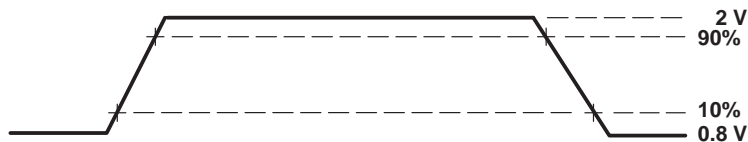

Figure 6. TTL-Level Inputs

PARAMETER MEASUREMENT INFORMATION

timing parameter symbology

Timing parameter symbols used herein were created in accordance with JEDEC Standard 100-A. In order to shorten the symbols, some of the pin names and other related terminology have been abbreviated as follows, unless otherwise noted:

A	(L)A30–(L)A0 or (L)Ax	IOS	$\overline{\text{IOSTRB}}$
ASYNCH	Asynchronous reset signals in the high-impedance state	(M)S	$\overline{\text{(M)STRB}}$, includes $\overline{\text{STRB}}$ and $\overline{\text{MSTRB}}$
CH	CLKX0 and CLKX1	RDY	$\overline{\text{RDY}}$
CI	CLKIN	RESET	$\overline{\text{RESET}}$
CLKR	CLKR0 and CLKR1	RW	$\text{R}/\overline{\text{W}}$
CONTROL	Control signals	S	$\overline{\text{(M)S}}$, which includes $\overline{\text{MSTRB}}$, $\overline{\text{STRB}}$; and IOS, $\overline{\text{IOSTRB}}$
D	D31–D0 or Dx	SCK	CLKX/R, includes CLKX0, CLKX1, CLKR0, and CLKR1
DR	DR0 and DR1	TCLK	TCLK0 and TCLK1
DX	DX0 and DX1	XA	XA12–XA0 or XAx
FS	FSX/R, includes FSX0, FSX1, FSR0, and FSR1	(X)A	Includes A23–A0 and XA12–XA0
FSR	FSR0 and RSR1	XD	XD31–XD0 or XDx
FSX	FSX0 and FSX1	(X)D	Includes D31–D0 and XD31–XD0
GPIO	General-purpose input/output (peripheral pins include CLKX0/1, CLKR0/1, DX0/1, DR0/1, FSX0/1, FSR0/1, TCLK0/1)	XF	XFx, includes XF0 and XF1
H	H1 and H3	XF0	XF0
H1	H1	XF1	XF1
H3	H3	XFIO	XFx switching from input to output
HOLD	$\overline{\text{HOLD}}$	XRDY	$\overline{\text{XRDY}}$
HOLDA	$\overline{\text{HOLDA}}$	(X)RDY	$\overline{\text{(X)RDY}}$, includes $\overline{\text{RDY}}$ and $\overline{\text{XRDY}}$
IACK	$\overline{\text{IACK}}$	XRW	$\text{XR}/\overline{\text{W}}$
INT	$\overline{\text{INT3}}$ – $\overline{\text{INT0}}$	(X)RW	$\overline{\text{(X)R}/\overline{\text{W}}}$, includes $\text{R}/\overline{\text{W}}$ and $\overline{\text{XR}/\overline{\text{W}}}$

TMS320C30 DIGITAL SIGNAL PROCESSOR

SPRS032A – APRIL 1996 – REVISED JUNE 1997

X2/CLKIN, H1, and H3 timing

The following table defines the timing parameters for the X2/CLKIN, H1, and H3 interface signals. The numbers shown in Figure 7 and Figure 8 correspond with those in the NO. column of the table below. Refer to the $\overline{\text{RESET}}$ timing in Figure 19 for CLKIN to H1 and H3 delay specification.

timing parameters for X2/CLKIN, H1, H3 (see Figure 7 and Figure 8)

NO.		'C30-27		'C30-33		'C30-40		'C30-50		UNIT
		MIN	MAX	MIN	MAX	MIN	MAX	MIN	MAX	
1	$t_f(\text{Cl})$ Fall time, CLKIN		6 [†]		5 [†]		5 [†]		5 [†]	ns
2	$t_w(\text{ClL})$ Pulse duration, CLKIN low $t_c(\text{Cl}) = \text{min}$	14		10		9		7		ns
3	$t_w(\text{ClH})$ Pulse duration, CLKIN high $t_c(\text{Cl}) = \text{min}$	14		10		9		7		ns
4	$t_r(\text{Cl})$ Rise time, CLKIN		6 [†]		5 [†]		5 [†]		5 [†]	ns
5	$t_c(\text{Cl})$ Cycle time, CLKIN	37	303	30	303	25	303	20	303	ns
6	$t_f(\text{H})$ Fall time, H1 and H3		4		3		3		3	ns
7	$t_w(\text{HL})$ Pulse duration, H1 and H3 low	P-6 [‡]		P-6 [‡]		P-5 [‡]		P-5 [‡]		ns
8	$t_w(\text{HH})$ Pulse duration, H1 and H3 high	P-7 [‡]		P-7 [‡]		P-6 [‡]		P-6 [‡]		ns
9	$t_r(\text{H})$ Rise time, H1 and H3		5		4		3		3	ns
9.1	$t_d(\text{HL-HH})$ Delay time, from H1 low to H3 high or from H3 low to H1 high	0	6	0	5	0	4	0	4	ns
10	$t_c(\text{H})$ Cycle time, H1 and H3	74	606	60	606	50	606	40	606	ns

[†] Specified by design but not tested

[‡] P = $t_c(\text{Cl})$

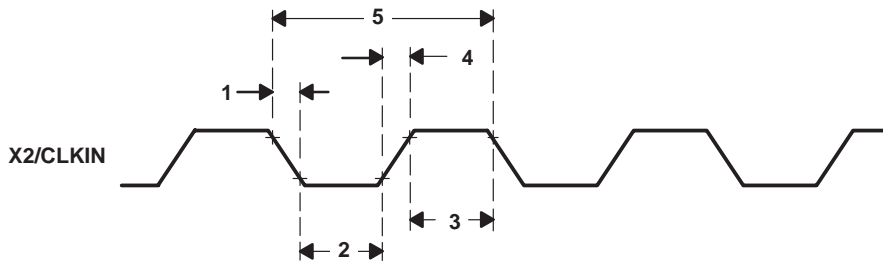

Figure 7. Timing for X2/CLKIN

X2/CLKIN, H1, and H3 timing (continued)

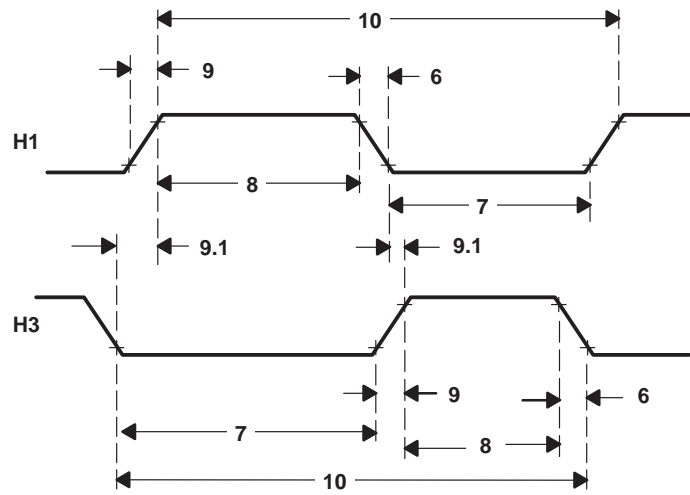

Figure 8. Timing for H1 and H3

memory read/write timing

The following table defines memory read/write timing parameters for $\overline{(M)STRB}$. The numbers shown in Figure 9 and Figure 10 correspond with those in the NO. column of the table.

timing parameters for a memory [$\overline{(M)STRB} = 0$] read/write (see Figure 9 and Figure 10)

NO.		'C30-27		'C30-33		'C30-40		'C30-50		UNIT
		MIN	MAX	MIN	MAX	MIN	MAX	MIN	MAX	
11	$t_{d[H1L-(M)SL]}$ Delay time, H1 low to $\overline{(M)STRB}$ low	0†	13	0†	10	0†	6‡	0†	4	ns
12	$t_{d[H1L-(M)SH]}$ Delay time, H1 low to $\overline{(M)STRB}$ high	0†	13	0†	10	0†	6	0†	4	ns
13.1	$t_{d(H1H-RWL)}$ Delay time, H1 high to R/\overline{W} low	0†	13	0†	10	0†	9	0†	7	ns
13.2	$t_{d(H1H-XRWL)}$ Delay time, H1 high to XR/\overline{W} low	0†	19	0†	15	0†	13	0†	11	ns
14.1	$t_{d(H1L-A)}$ Delay time, H1 low to A valid	0†	16	0†	14	0†	11	0†	9	ns
14.2	$t_{d(H1L-XA)}$ Delay time, H1 low to XA valid	0†	12	0†	10	0†	9	0†	8	ns
15.1	$t_{su(D-H1L)R}$ Setup time, D before H1 low (read)	18		16		14		10		ns
15.2	$t_{su(XD-H1L)R}$ Setup time, XD before H1 low (read)	21		18		16		14		ns
16	$t_h[H1L-(X)DJR]$ Hold time, (X)D after H1 low (read)	0		0		0		0		ns
17.1	$t_{su(RDY-H1H)}$ Setup time, \overline{RDY} before H1 high	10		8		8		6		ns
17.2	$t_{su(XRDY-H1H)}$ Setup time, \overline{XRDY} before H1 high	11		9		9		8		ns
18	$t_h[H1H-(X)RDY]$ Hold time, $\overline{(X)RDY}$ after H1 high	0		0		0		0		ns
19	$t_{d[H1H-(X)RWH]W}$ Delay time, H1 high to (X) R/\overline{W} high (write)		13		10		9		7	ns
20	$t_v[H1L-(X)DJW]$ Valid time, (X)D after H1 low (write)		25		20		17		14	ns
21	$t_h[H1H-(X)DJW]$ Hold time, (X)D after H1 high (write)	0†		0†		0†		0†		ns
22.1	$t_{d(H1H-A)W}$ Delay time, H1 high to A valid on back-to-back write cycles (write)		23		18		15		12	ns
22.2	$t_{d(H1H-XA)W}$ Delay time, H1 high to XA valid on back-to-back write cycles (write)		32		25		21		18	ns
26	$t_{d[A-(X)RDY]}$ Delay time, $\overline{(X)RDY}$ from A valid		10§		8§		7§		6	ns

† Specified by design but not tested

‡ For 'C30 PPM, $t_{d[H1L-(M)SL]}$ (max)=7 ns

§ This value is characterized but not tested

memory read/write timing (continued)

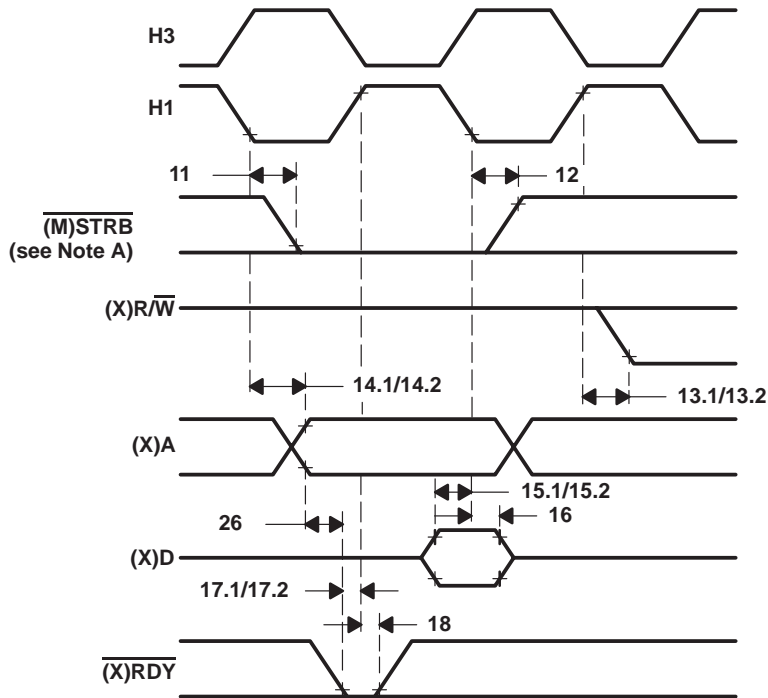

NOTE A: $\overline{(M)STRB}$ remains low during back-to-back read operations.

Figure 9. Timing for Memory $[\overline{(M)STRB} = 0]$ Read

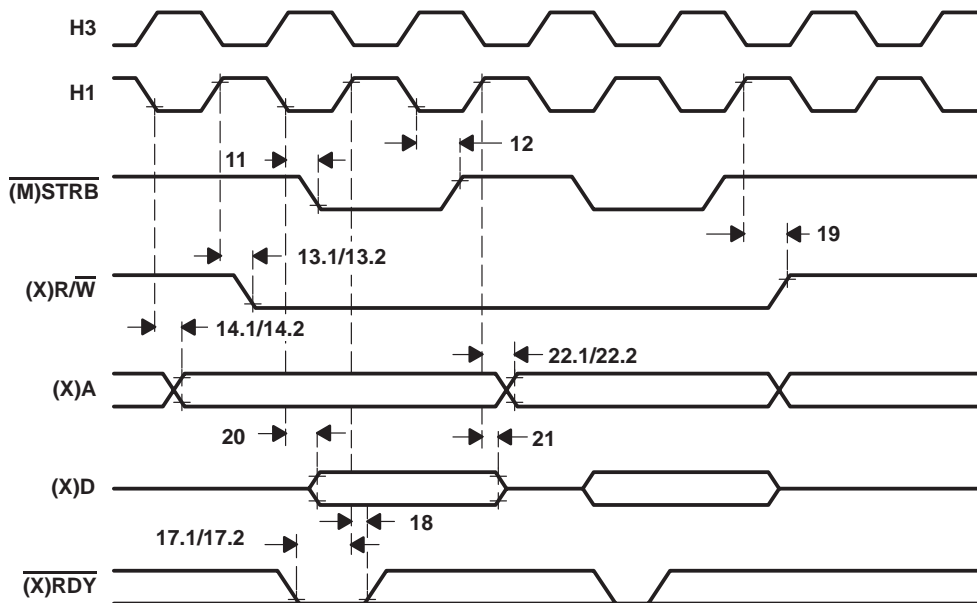

Figure 10. Timing for Memory $[\overline{(M)STRB} = 0]$ Write

TMS320C30 DIGITAL SIGNAL PROCESSOR

SPRS032A – APRIL 1996 – REVISED JUNE 1997

memory read/write timing (continued)

The following table defines memory read timing parameters for $\overline{\text{IOSTRB}}$. The numbers shown in Figure 11 correspond with those in the NO. column of the table below.

timing parameters for a memory ($\overline{\text{IOSTRB}} = 0$) read (see Figure 11)

NO.		'C30-27		'C30-33		'C30-40		'C30-50		UNIT
		MIN	MAX	MIN	MAX	MIN	MAX	MIN	MAX	
11.1	$t_{d(H1H\text{-}IOSL)$ Delay time, H1 high to $\overline{\text{IOSTRB}}$ low	0†	13	0†	10	0†	9	0†	8	ns
12.1	$t_{d(H1H\text{-}IOSH)$ Delay time, H1 high to $\overline{\text{IOSTRB}}$ high	0†	13	0†	10	0†	9	0†	8	ns
13.1	$t_{d(H1L\text{-}XRWH)$ Delay time, H1 low to $\overline{\text{XR}}/\overline{\text{W}}$ high	0†	13	0†	10	0†	9	0	8	ns
14.3	$t_{d(H1L\text{-}XA)$ Delay time, H1 low to XA valid	0†	13	0†	10	0†	9	0†	8	ns
15.3	$t_{su(XD\text{-}H1H)R}$ Setup time, XD before H1 high (read)	19		15		13		11		ns
16.1	$t_{hH1H\text{-}XD)R}$ Hold time, XD after H1 high (read)	0		0		0		0		ns
17.3	$t_{su(XRDY\text{-}H1H)$ Setup time, $\overline{\text{XRDY}}$ before H1 high	11		9		9		8		ns
18.1	$t_{h(H1H\text{-}XRDY)$ Hold time, $\overline{\text{XRDY}}$ after H1 high	0		0		0		0		ns
23	$t_{d(H1L\text{-}XRWL)$ Delay time, H1 low to $\overline{\text{XR}}/\overline{\text{W}}$ low	0†	19	0†	15	0†	13	0†	11	ns

† This value is characterized but not tested

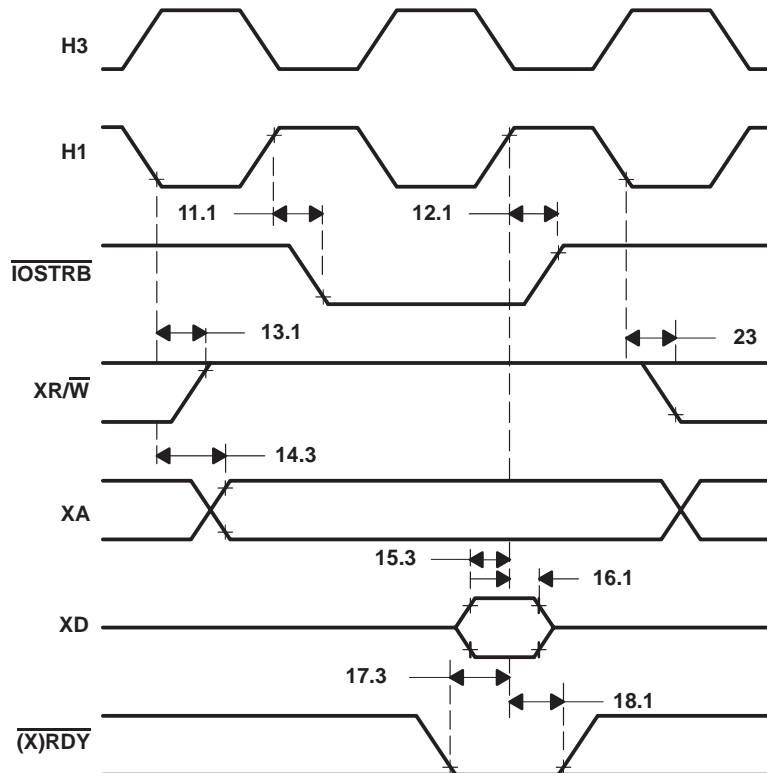

Figure 11. Timing for Memory ($\overline{\text{IOSTRB}} = 0$) Read

memory read/write timing (continued)

The following table defines memory write timing parameters for $\overline{\text{IOSTRB}}$. The numbers shown in Figure 12 correspond with those in the NO. column of the table below.

timing parameters for a memory ($\overline{\text{IOSTRB}} = 0$) write (see Figure 12)

NO.		'C30-27		'C30-33		'C30-40		'C30-50		UNIT
		MIN	MAX	MIN	MAX	MIN	MAX	MIN	MAX	
11.1	$t_d(\text{H1H-IOSL})$ Delay time, H1 high to $\overline{\text{IOSTRB}}$ low	0†	13	0†	10	0†	9	0†	8	ns
12.1	$t_d(\text{H1H-IOSH})$ Delay time, H1 high to $\overline{\text{IOSTRB}}$ high	0†	13	0†	10	0†	9	0†	8	ns
13.1	$t_d(\text{H1L-XRWH})$ Delay time, H1 low to $\overline{\text{XR/W}}$ high	0†	13	0†	10	0†	9	0	8	ns
14.3	$t_d(\text{H1L-XA})$ Delay time, H1 low to XA valid	0†	13	0†	10	0†	9	0†	8	ns
17.3	$t_{su}(\text{XRDY-H1H})$ Setup time, $\overline{\text{XRDY}}$ before H1 high	11		9		9		8		ns
18.1	$t_h(\text{H1H-XRDY})$ Hold time, $\overline{\text{XRDY}}$ after H1 high	0		0		0		0		ns
23	$t_d(\text{H1L-XRWL})$ Delay time, H1 low to $\overline{\text{XR/W}}$ low	0†	19	0†	15	0†	13	0†	11	ns
24	$t_v(\text{H1H-XD})W$ Valid time, (X)D after H1 high (write)		38		30		25		20	ns
25	$t_h(\text{H1L-XD})W$ Hold time, (X)D after H1 low (write)	0		0		0		0		ns

† This value is characterized but not tested

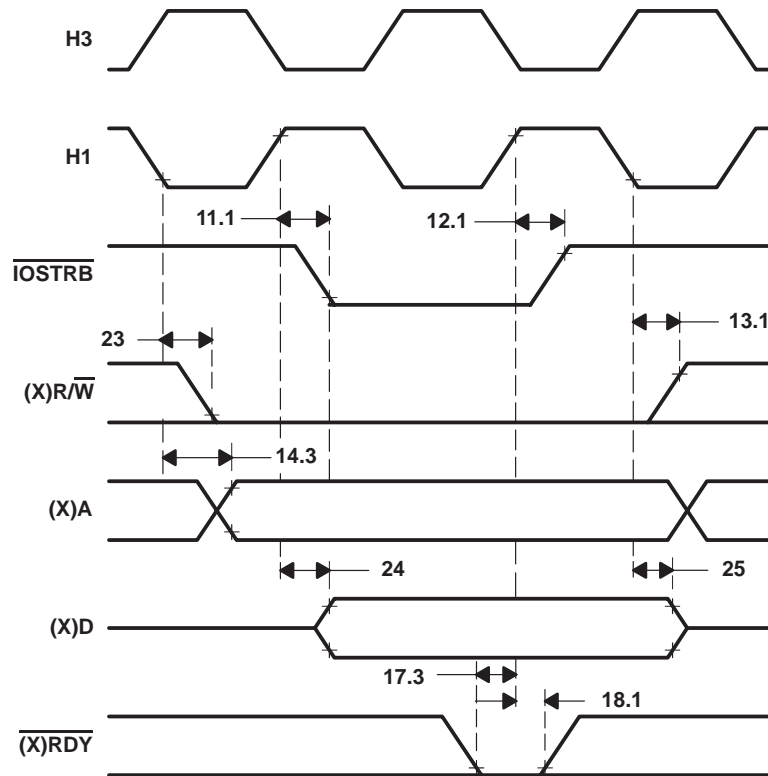

Figure 12. Timing for Memory ($\overline{\text{IOSTRB}} = 0$) Write

TMS320C30 DIGITAL SIGNAL PROCESSOR

SPRS032A – APRIL 1996 – REVISED JUNE 1997

XF0 and XF1 timing when executing LDFI or LDII

The following table defines the timing parameters for XF0 and XF1 during execution of LDFI or LDII. The numbers shown in Figure 13 correspond with those in the NO. column of the table below.

timing parameters for XF0 and XF1 when executing LDFI or LDII (see Figure 13)

NO.		'C30-27		'C30-33		'C30-40		'C30-50		UNIT
		MIN	MAX	MIN	MAX	MIN	MAX	MIN	MAX	
1	$t_d(H3H-XF0L)$ Delay time, H3 high to XF0 low		19		15		13		12	ns
2	$t_{su}(XF1-H1L)$ Setup time, XF1 before H1 low	13		10		9		9		ns
3	$t_h(H1L-XF1)$ Hold time, XF1 after H1 low	0		0		0		0		ns

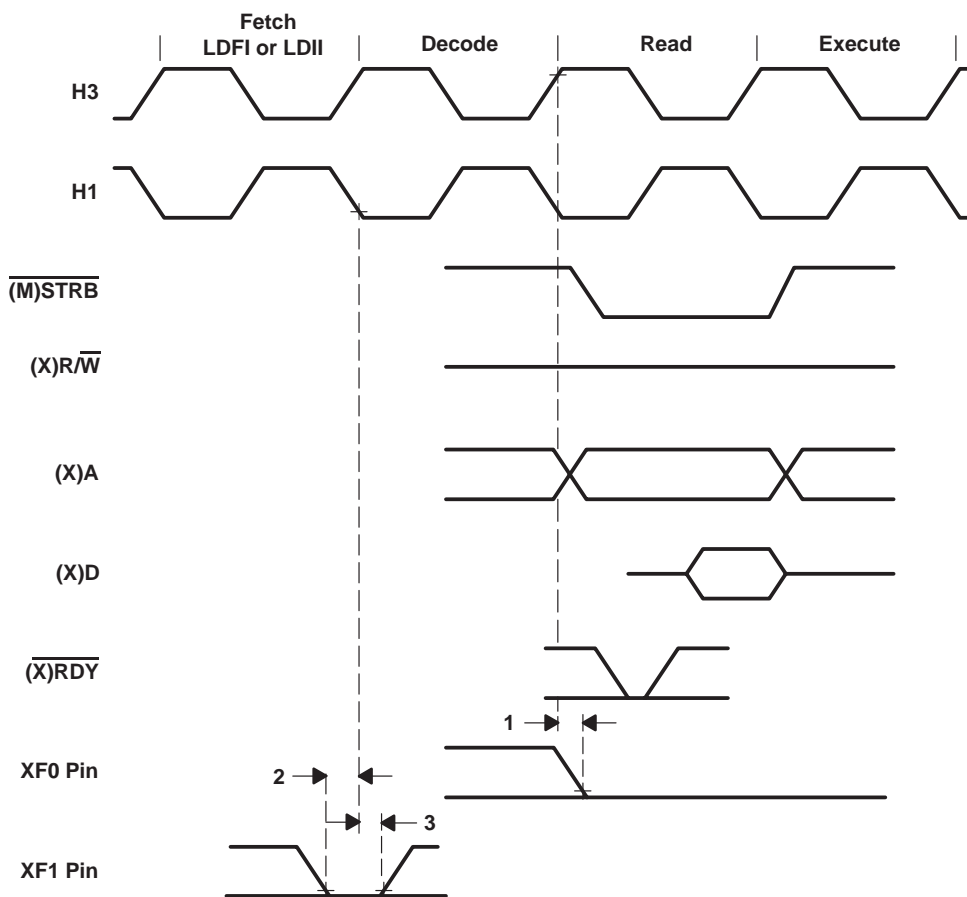

Figure 13. Timing for XF0 and XF1 When Executing LDFI or LDII

XF0 timing when executing STFI and STII

The following table defines the timing parameters for the XF0 pin during execution of STFI or STII. The number shown in Figure 14 corresponds with the number in the NO. column of the table below.

timing parameters for XF0 when executing STFI or STII (see Figure 14)

NO.		'C30-27		'C30-33		'C30-40		'C30-50		UNIT
		MIN	MAX	MIN	MAX	MIN	MAX	MIN	MAX	
1	$t_{d(H3H-XF0H)}$ Delay time, H3 high to XF0 high		19		15		13		12	ns

XF0 is always set high at the beginning of the execute phase of the interlock store instruction. When no pipeline conflicts occur, the address of the store is also driven at the beginning of the execute phase of the interlock store instruction. However, if a pipeline conflict prevents the store from executing, the address of the store will not be driven until the store can execute.

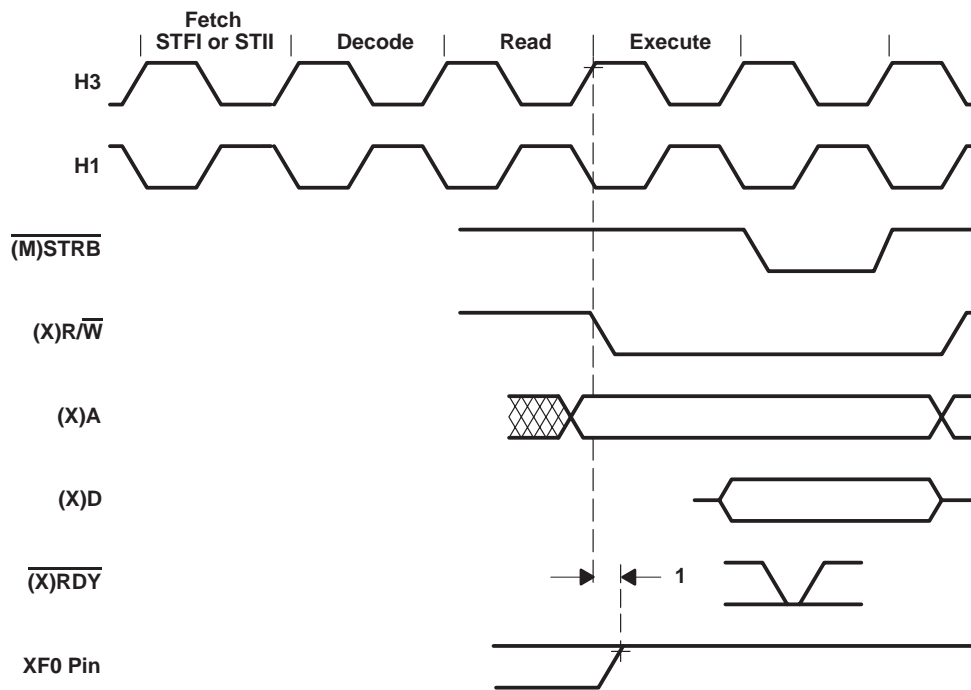

Figure 14. Timing for XF0 When Executing an STFI or STII

TMS320C30 DIGITAL SIGNAL PROCESSOR

SPRS032A – APRIL 1996 – REVISED JUNE 1997

XF0 and XF1 timing when executing SIGI

The following table defines the timing parameters for the XF0 and XF1 pins during execution of SIGI. The numbers shown in Figure 15 correspond with those in the NO. column of the table below.

timing parameters for XF0 and XF1 when executing SIGI (see Figure 15)

NO.		'C30-27		'C30-33		'C30-40		'C30-50		UNIT
		MIN	MAX	MIN	MAX	MIN	MAX	MIN	MAX	
1	$t_d(H3H-XF0L)$ Delay time, H3 high to XF0 low		19		15		13		12	ns
2	$t_d(H3H-XF0H)$ Delay time, H3 high to XF0 high		19		15		13		12	ns
3	$t_{su}(XF1-H1L)$ Setup time, XF1 before H1 low	13		10		9		9		ns
4	$t_h(H1L-XF1)$ Hold time, XF1 after H1 low	0		0		0		0		ns

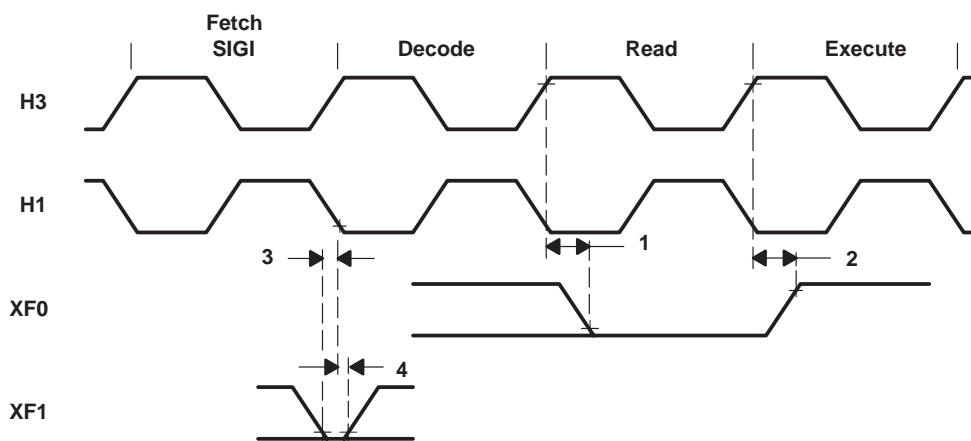

Figure 15. Timing for XF0 and XF1 When Executing SIGI

loading when XF_x is configured as an output

The following table defines the timing parameter for loading the XF register when the XF_x pin is configured as an output. The number shown in Figure 16 corresponds with the number in the NO. column of the table below.

timing parameters for loading the XF_x register when configured as an output pin (see Figure 16)

NO.		'C30-27		'C30-33		'C30-40		'C30-50		UNIT
		MIN	MAX	MIN	MAX	MIN	MAX	MIN	MAX	
1	$t_{v(H3H-XF)}$ Valid time, H3 high to XF _x	19		15		13		12		ns

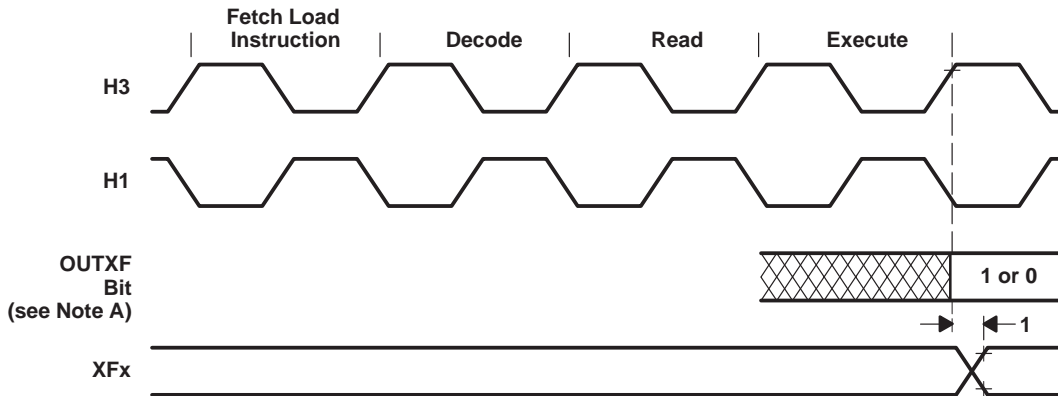

NOTE A: OUTXF_x represents either bit 2 or 6 of the IOF register.

Figure 16. Timing for Loading XF_x Register When Configured as an Output Pin

changing XFx from an output to an input

The following table defines the timing parameters for changing the XFx pin from an output pin to an input pin. The numbers shown in Figure 17 correspond with those in the NO. column of the table below.

timing parameters of XFx changing from output to input mode (see Figure 17)

NO.		'C30-27		'C30-33		'C30-40		'C30-50		UNIT
		MIN	MAX	MIN	MAX	MIN	MAX	MIN	MAX	
1	$t_h(H3H-XF)$ Hold time, XFx after H3 high		19‡		15‡		13†‡		12‡	ns
2	$t_{su}(XF-H1L)$ Setup time, XFx before H1 low	13		10		9		9		ns
3	$t_h(H1L-XF)$ Hold time, XFx after H1 low	0		0		0		0		ns

† For 'C30 PPM, $t_h(H3H-XF01)$ (max)=14 ns

‡ This value is characterized but not tested

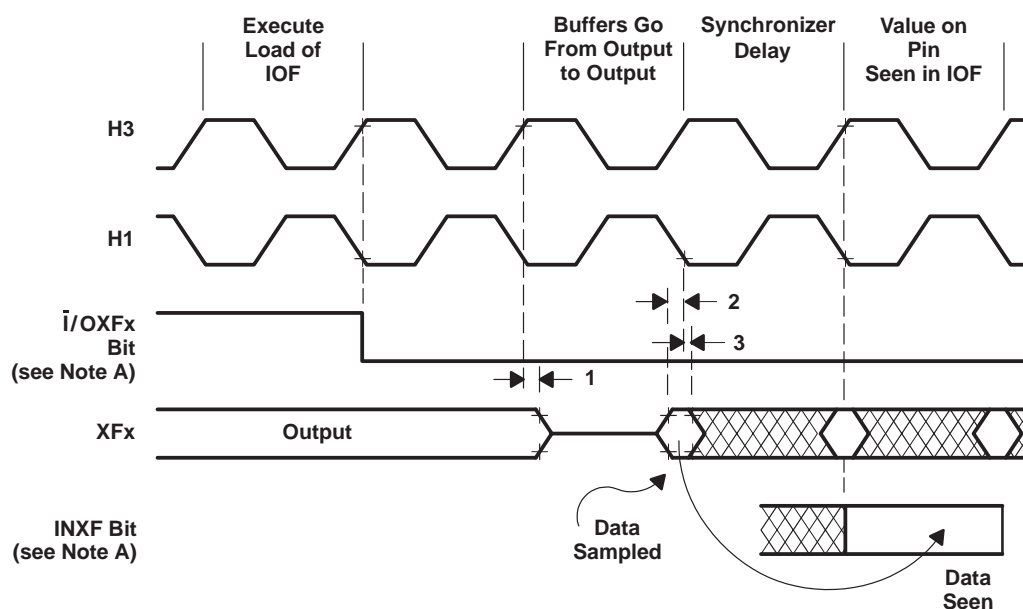

NOTE A: $\bar{i}/OXFx$ represents bit 1 or 5 of the IOF register, and $INXFx$ represents either bit 3 or bit 7 of the IOF register.

Figure 17. Timing for Change of XFx From Output to Input Mode

changing XFx from an input to an output

The following table defines the timing parameter for changing the XFx pin from an input pin to an output pin. The number shown in Figure 18 corresponds with the number in the NO. column of the table below.

timing parameters of XFx changing from input to output mode (see Figure 18)

NO.		'C30-27		'C30-33		'C30-40		'C30-50		UNIT
		MIN	MAX	MIN	MAX	MIN	MAX	MIN	MAX	
1	$t_{d(H3H-XFIO)}$ Delay time, H3 high to XFx switching from input to output		25		20		17		17	ns

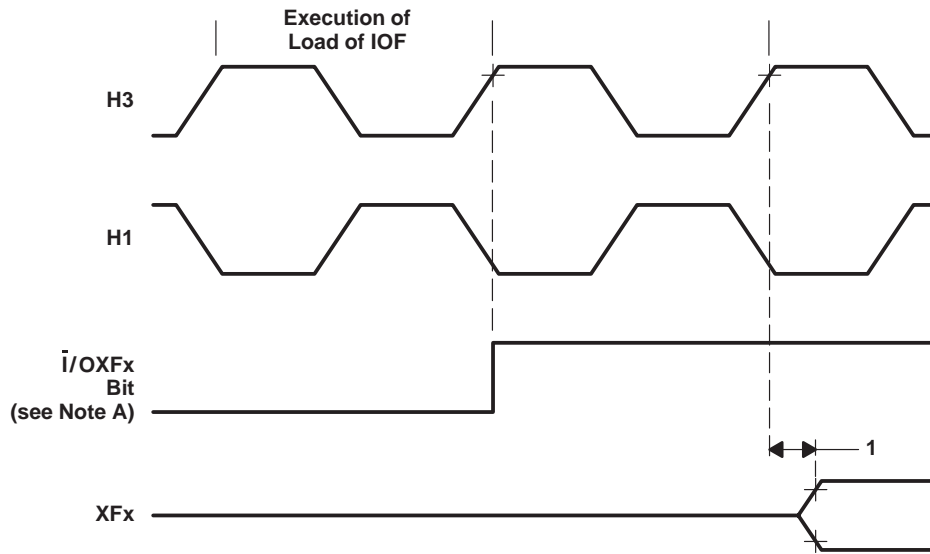

NOTE A: \bar{I}/OXF_x represents either bit 1 or 5 of the IOF register.

Figure 18. Timing for Change of XFx From Input to Output Mode

reset timing

$\overline{\text{RESET}}$ is an asynchronous input that can be asserted at any time during a clock cycle. If the specified timings are met, the exact sequence shown in Figure 19 occurs; otherwise, an additional delay of one clock cycle is possible.

The asynchronous reset signals include XF0/1, CLKX0/1, DX0/1, FSX0/1, CLKR0/1, DR0/1, FSR0/1, and TCLK0/1.

The following table defines the timing parameters for the $\overline{\text{RESET}}$ signal. The numbers shown in Figure 19 correspond with those in the NO. column of the following table.

Resetting the device initializes the primary- and expansion-bus control registers to seven software wait states and therefore results in slow external accesses until these registers are initialized.

Note also that $\overline{\text{HOLD}}$ is an asynchronous input and can be asserted during reset.

timing parameters for $\overline{\text{RESET}}$ for the TMS320C30 (see Figure 19)

NO.			'C30-27		'C30-33		'C30-40		'C30-50		UNIT
			MIN	MAX	MIN	MAX	MIN	MAX	MIN	MAX	
1	$t_{su}(\text{RESET-CIL})$	Setup time, $\overline{\text{RESET}}$ before CLKIN low	28	P††	10	P††	10	P††	10	P††	ns
2.1	$t_d(\text{CIH-H1H})$	Delay time, CLKIN high to H1 high§¶	2	20	2	14	2	12	2	10	ns
2.2	$t_d(\text{CIH-H1L})$	Delay time, CLKIN high to H1 low§¶	2	20	2	14	2	12	2	10	ns
3	$t_{su}(\text{RESETH-H1L})$	Setup time, $\overline{\text{RESET}}$ high before H1 low and after ten H1 clock cycles	13		10		9		7		ns
5.1	$t_d(\text{CIH-H3L})$	Delay time, CLKIN high to H3 low§¶	2	20	2	14	2	12	2	10	ns
5.2	$t_d(\text{CIH-H3H})$	Delay time, CLKIN high to H3 high§¶	2	20	2	14	2	12	2	10	ns
8	$t_{dis}[\text{H1H-(X)D}]$	Disable time, H1 high to (X)D (high impedance)		19†		15†		13†		12†	ns
9	$t_{dis}[\text{H3H-(X)A}]$	Disable time, H3 high to (X)A (high impedance)		13†		10†		9†		8†	ns
10	$t_d(\text{H3H-CONTROLH})$	Delay time, H3 high to control signals high		13†		10†		9†		8†	ns
12	$t_d(\text{H1H-RWH})$	Delay time, H1 high to $\overline{\text{R/W}}$ high		13†		10†		9†		8†	ns
13	$t_d(\text{H1H-IACKH})$	Delay time, H1 high to $\overline{\text{IACK}}$ high		13†		10†		9†		8†	ns
14	$t_{dis}(\text{RESETL-ASYNCH})$	Disable time, $\overline{\text{RESET}}$ low to asynchronous reset signals (high impedance)		31†		25†		21†		17†	ns

† This value is characterized but not tested

‡ P = $t_c(\text{CI})$

§ See Figure 20 for temperature dependence for the 33-MHz and the 40-MHz TMS320C30.

¶ See Figure 21 for temperature dependence for the 50-MHz TMS320C30.

reset timing (continued)

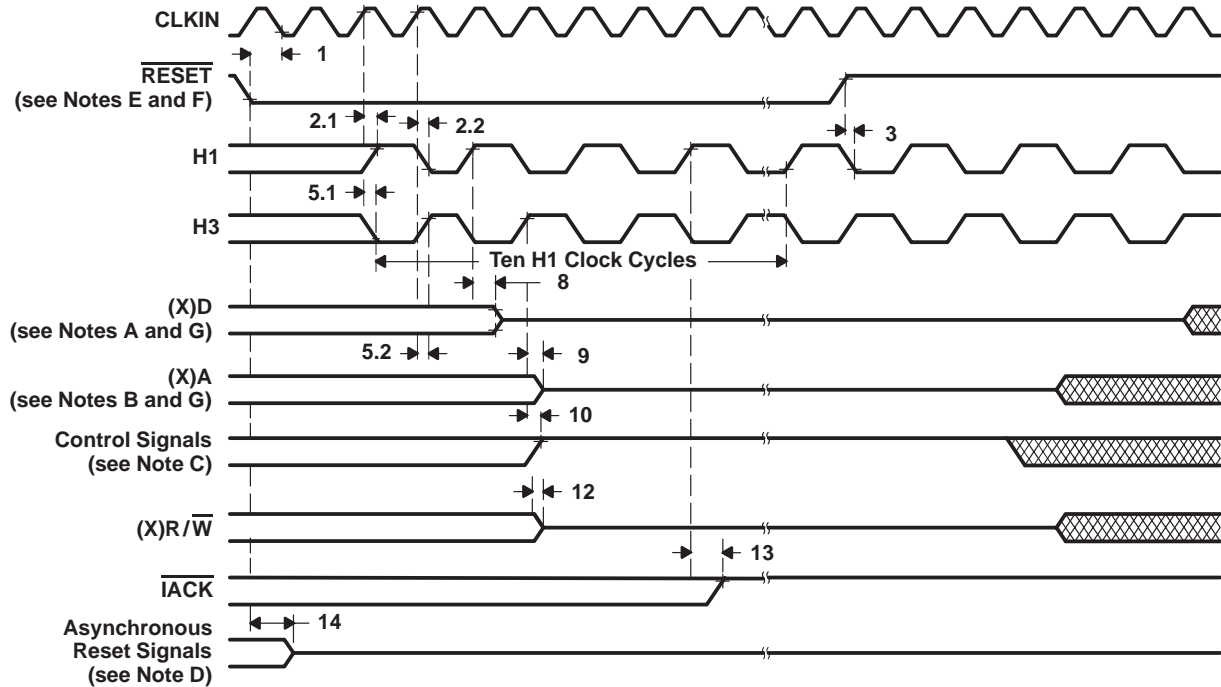

- NOTES:
- (X)D includes D31–D0 and XD31–XD0.
 - (X)A includes A23–A0 and XA12–XA0.
 - Interface signals include STRB, MSTRB, and IOSTRB.
 - Asynchronous reset signals include XF0/1, CLKX0/1, DX0/1, FSX0/1, CLKR0/1, DR0/1, FSR0/1, and TCLK0/1.
 - RESET is an asynchronous input and can be asserted at any point during a clock cycle. If the specified timings are met, the exact sequence shown occurs; otherwise, an additional delay of one clock cycle is possible.
 - The R/W and XR/W outputs are placed in a high-impedance state during reset and can be provided with a resistive pullup, nominally 18–22 kΩ, if undesirable spurious writes could be caused when these outputs go low.
 - In microprocessor mode, the reset vector is fetched twice, with seven software wait states each time. In microcomputer mode, the reset vector is fetched twice, with no software wait states.

Figure 19. Timing for RESET

reset timing (continued)

Figure 20 and Figure 21 illustrate CLKIN-to-H1 and CLKIN-to-H3 timing as a function of case temperature.

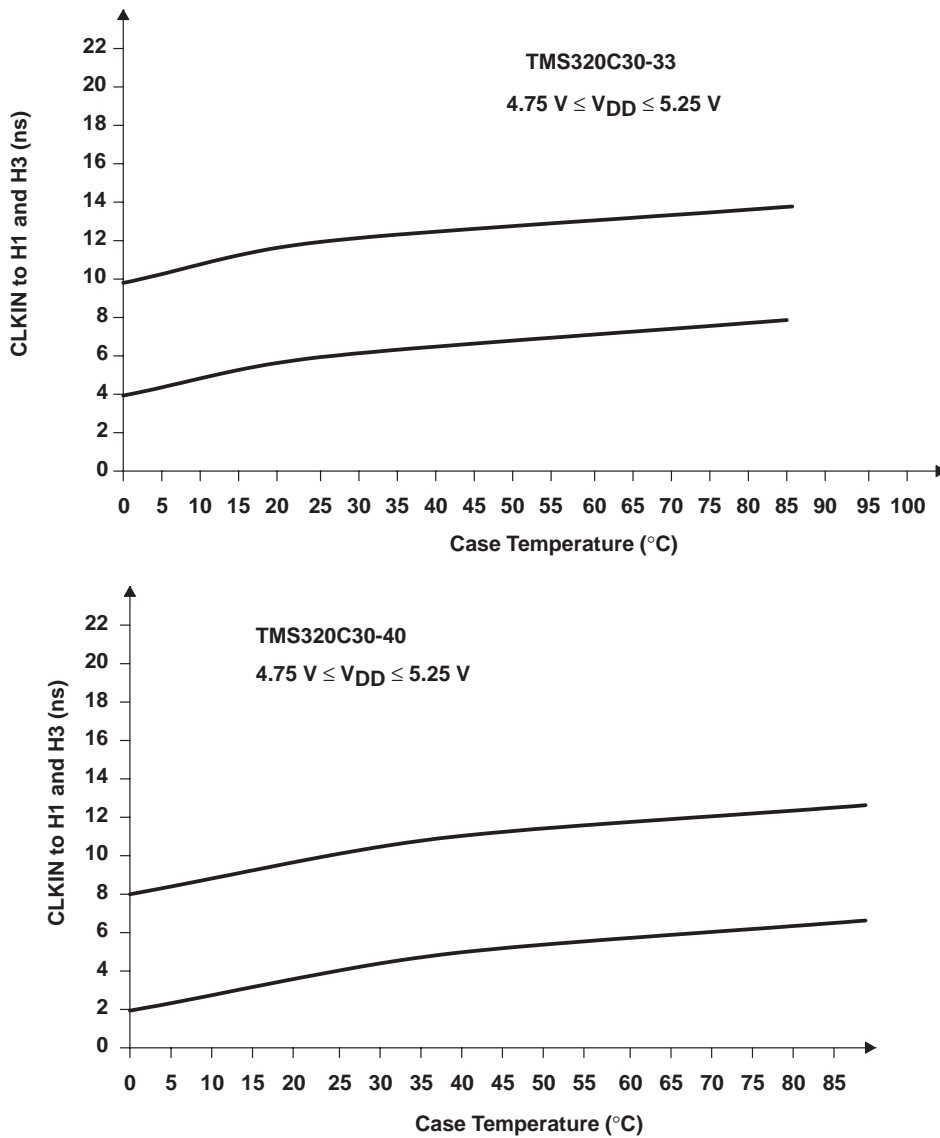

Figure 20. CLKIN to H1 and H3 as a Function of Temperature

reset timing (continued)

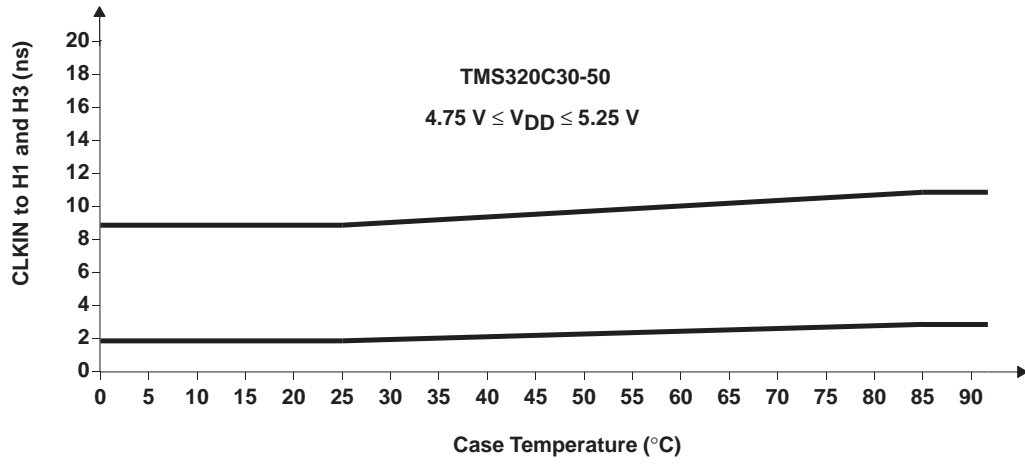

Figure 21. CLKIN to H1 and H3 as a Function of Temperature

interrupt response timing

The following table defines the timing parameters for the $\overline{\text{INT}}$ signals. The numbers shown in Figure 22 correspond with those in the NO. column of the table below.

timing parameters for $\overline{\text{INT3}}\text{--}\overline{\text{INT0}}$ (see Figure 22)

NO.		'C30-27		'C30-33		'C30-40		'C30-50		UNIT
		MIN	MAX	MIN	MAX	MIN	MAX	MIN	MAX	
1	$t_{\text{su}}(\text{INT-H1L})$ Setup time, $\overline{\text{INT3}}\text{--}\overline{\text{INT0}}$ before H1 low	19		15		13		10		ns
2	$t_{\text{w}}(\text{INT})$ Pulse duration, interrupt to ensure only one interrupt	P	2P†‡	P	2P†‡	P	2P†‡	P	2P†‡	ns

† Characterized but not tested

‡ P = $t_{\text{c}}(\text{H})$

The interrupt ($\overline{\text{INT}}$) pins are asynchronous inputs that can be asserted at any time during a clock cycle. The TMS320C30 interrupts are level-sensitive, not edge-sensitive. Interrupts are detected on the falling edge of H1. Therefore, interrupts must be set up and held to the falling edge of H1 for proper detection. The CPU and DMA respond to detected interrupts on instruction-fetch boundaries only.

For the processor to recognize only one interrupt on a given input, an interrupt pulse must be set up and held to:

- A minimum of one H1 falling edge
- No more than two H1 falling edges

The TMS320C30 can accept an interrupt from the same source every two H1 clock cycles.

If the specified timings are met, the exact sequence shown in Figure 22 occurs; otherwise, an additional delay of one clock cycle is possible.

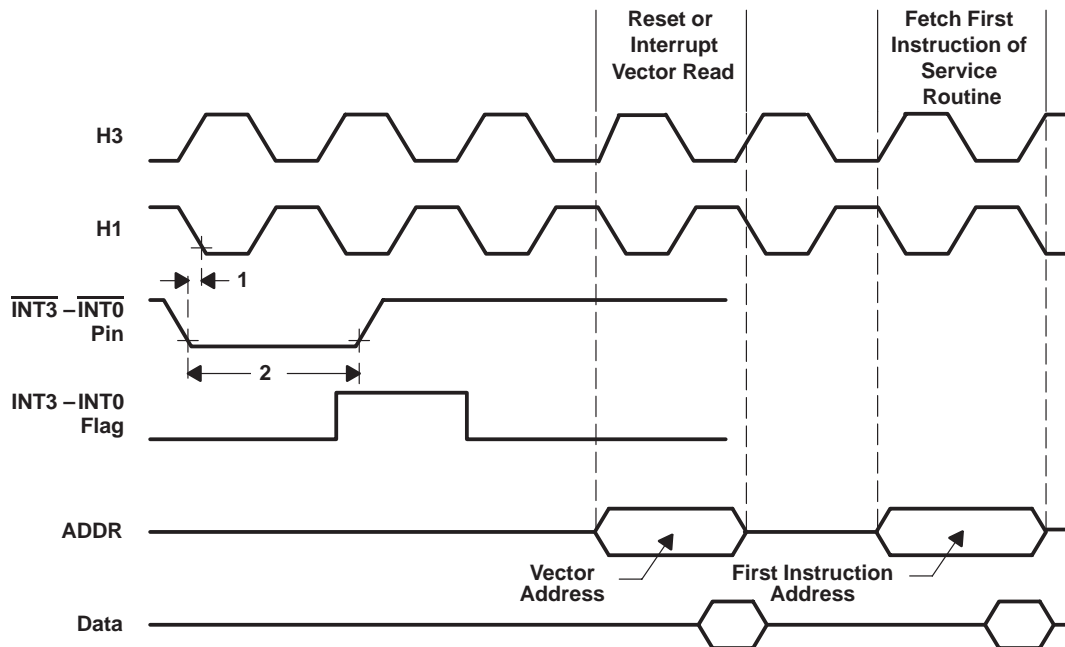

Figure 22. Timing for $\overline{\text{INT3}}\text{--}\overline{\text{INT0}}$ Response

interrupt-acknowledge timing

The $\overline{\text{IACK}}$ output goes active on the first half-cycle (H1 rising) of the decode phase of the IACK instruction and goes inactive at the first half-cycle (H1 rising) of the read phase of the IACK instruction.

The following table defines the timing parameters for the $\overline{\text{IACK}}$ signal. The numbers shown in Figure 23 correspond with those in the NO. column of the table below.

timing parameters for $\overline{\text{IACK}}$ (see Note 6 and Figure 23)

NO.		'C30-27		'C30-33		'C30-40		'C30-50		UNIT
		MIN	MAX	MIN	MAX	MIN	MAX	MIN	MAX	
1	$t_{d(H1H-IACKL)}$ Delay time, H1 high to $\overline{\text{IACK}}$ low		13		10		9		7	ns
2	$t_{d(H1H-IACKH)}$ Delay time, H1 high to $\overline{\text{IACK}}$ high		13		10		9		7	ns

NOTE 6: $\overline{\text{IACK}}$ goes active on the first half-cycle (H1 rising) of the decode phase of the IACK instruction and goes inactive at the first half-cycle (H1 rising) of the read phase of the IACK instruction. Because of the pipeline conflicts, $\overline{\text{IACK}}$ remains low for one cycle even if the decode phase of the IACK instruction is extended.

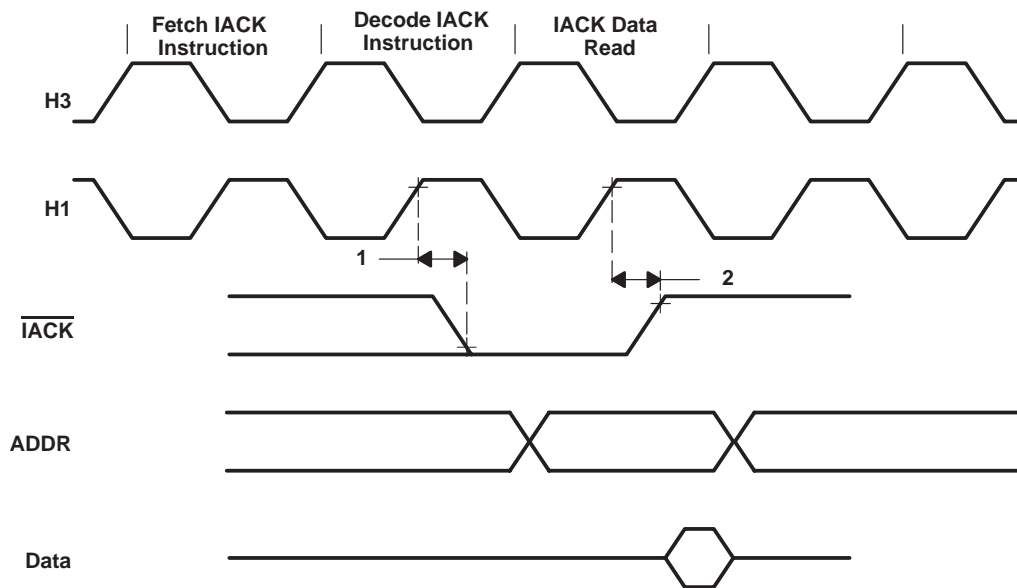

Figure 23. Timing for $\overline{\text{IACK}}$

TMS320C30 DIGITAL SIGNAL PROCESSOR

SPRS032A – APRIL 1996 – REVISED JUNE 1997

serial-port timing parameters (see Figure 24 and Figure 25)

NO.			'320C30-27		UNIT
			MIN	MAX	
1	$t_d(H1H-SCK)$	Delay time, H1 high to internal CLKX/R		19	ns
2	$t_c(SCK)$	Cycle time, CLKX/R	CLKX/R ext	$t_c(H) \times 2.6$	ns
			CLKX/R int	$t_c(H) \times 2$ $t_c(H) \times 2^{32}$	
3	$t_w(SCK)$	Pulse duration, CLKX/R high/low	CLKX/R ext	$t_c(H) + 12$	ns
			CLKX/R int	$[t_c(SCK)/2] - 15$ $[t_c(SCK)/2] + 5$	
4	$t_r(SCK)$	Rise time, CLKX/R		10	ns
5	$t_f(SCK)$	Fall time, CLKX/R		10	ns
6	$t_d(CH-DX)$	Delay time, CLKX to DX valid	CLKX ext	44	ns
			CLKX int	25	
7	$t_{su}(DR-CLKRL)$	Setup time, DR before CLKR low	CLKR ext	13	ns
			CLKR int	31	
8	$t_h(CLKRL-DR)$	Hold time, DR from CLKR low	CLKR ext	13	ns
			CLKR int	0	
9	$t_d(CH-FSX)$	Delay time, CLKX to internal FSX high/low	CLKX ext	40	ns
			CLKX int	21	
10	$t_{su}(FSR-CLKRL)$	Setup time, FSR0 or FSR1 before CLKR low	CLKR ext	13	ns
			CLKR int	13	
11	$t_h(SCKL-FS)$	Hold time, FSX/R input from CLKX/R low	CLKX/R ext	13	ns
			CLKX/R int	0	
12	$t_{su}(FSX-CH)$	Setup time, external FSX before CLKX	CLKX ext	$-[t_c(H) - 8]^\dagger$ $[t_c(SCK)/2] - 10^\dagger$	ns
			CLKX int	$-[t_c(H) - 21]^\dagger$ $t_c(SCK)/2^\dagger$	
13	$t_d(CH-DX)V$	Delay time, CLKX to first DX bit, FSX0 or FSX1 precedes CLKX high	CLKX ext	45^\dagger	ns
			CLKX int	26^\dagger	
14	$t_d(FSX-DX)V$	Delay time, FSX0 or FSX1 to first DX bit, CLKX precedes FSX0 or FSX1		45^\dagger	ns
15	$t_d(CHH-DXZ)$	Delay time, CLKX high to DX high impedance following last data bit		25^\dagger	ns

† This value is characterized but not tested



serial-port timing parameters (see Figure 24 and Figure 25) (continued)

NO.			'320C30-33		UNIT
			MIN	MAX	
1	$t_d(H1H-SCK)$	Delay time, H1 high to internal CLKX/R	15		ns
2	$t_c(SCK)$	Cycle time, CLKX/R	CLKX/R ext	$t_c(H) \times 2.6$	ns
			CLKX/R int	$t_c(H) \times 2$ $t_c(H) \times 2^{32}$	
3	$t_w(SCK)$	Pulse duration, CLKX/R high/low	CLKX/R ext	$t_c(H) + 12$	ns
			CLKX/R int	$[t_c(SCK)/2] - 15$ $[t_c(SCK)/2] + 5$	
4	$t_r(SCK)$	Rise time, CLKX/R	8		ns
5	$t_f(SCK)$	Fall time, CLKX/R	8		ns
6	$t_d(CH-DX)$	Delay time, CLKX to DX valid	CLKX ext	35	ns
			CLKX int	20	
7	$t_{su}(DR-CLKRL)$	Setup time, DR before CLKR low	CLKR ext	10	ns
			CLKR int	25	
8	$t_h(CLKRL-DR)$	Hold time, DR from CLKR low	CLKR ext	10	ns
			CLKR int	0	
9	$t_d(CH-FSX)$	Delay time, CLKX to internal FSX high/low	CLKX ext	32	ns
			CLKX int	17	
10	$t_{su}(FSR-CLKRL)$	Setup time, FSR before CLKR low	CLKR ext	10	ns
			CLKR int	10	
11	$t_h(SCKL-FS)$	Hold time, FSX/R input from CLKX/R low	CLKX/R ext	10	ns
			CLKX/R int	0	
12	$t_{su}(FSX-CH)$	Setup time, external FSX before CLKX	CLKX ext	$-[t_c(H) - 8]^\dagger$ $[t_c(SCK)/2] - 10^\dagger$	ns
			CLKX int	$[t_c(H) - 21]^\dagger$ $t_c(SCK)/2^\dagger$	
13	$t_d(CH-DX)V$	Delay time, CLKX to first DX bit, FSX precedes CLKX high	CLKX ext	36^\dagger	ns
			CLKX int	21^\dagger	
14	$t_d(FSX-DX)V$	Delay time, FSX to first DX bit, CLKX precedes FSX	36^\dagger		ns
15	$t_d(CHH-DXZ)$	Delay time, CLKX high to DX high impedance following last data bit	20^\dagger		ns

† This value is characterized but not tested

TMS320C30 DIGITAL SIGNAL PROCESSOR

SPRS032A – APRIL 1996 – REVISED JUNE 1997

serial-port timing parameters (see Figure 24 and Figure 25) (continued)

NO.			'320C30-40		UNIT
			MIN	MAX	
1	$t_{d(H1H-SCK)}$	Delay time, H1 high to internal CLKX/R		13	ns
2	$t_c(SCK)$	Cycle time, CLKX/R	CLKX/R ext	$t_c(H) \times 2.6$	ns
			CLKX/R int	$t_c(H) \times 2$ $t_c(H) \times 2^{32}$	
3	$t_w(SCK)$	Pulse duration, CLKX/R high/low	CLKX/R ext	$t_c(H) + 10$	ns
			CLKX/R int	$[t_c(SCK)/2] - 5$ $[t_c(SCK)/2] + 5$	
4	$t_r(SCK)$	Rise time, CLKX/R		7	ns
5	$t_f(SCK)$	Fall time, CLKX/R		7	ns
6	$t_d(CH-DX)$	Delay time, CLKX to DX valid	CLKX ext	30	ns
			CLKX int	17	
7	$t_{su}(DR-CLKRL)$	Setup time, DR before CLKR low	CLKR ext	9	ns
			CLKR int	21	
8	$t_h(CLKRL-DR)$	Hold time, DR from CLKR low	CLKR ext	9	ns
			CLKR int	0	
9	$t_d(CH-FSX)$	Delay time, CLKX to internal FSX high/low	CLKX ext	27	ns
			CLKX int	15	
10	$t_{su}(FSR-CLKRL)$	Setup time, FSR before CLKR low	CLKR ext	9	ns
			CLKR int	9	
11	$t_h(SCKL-FS)$	Hold time, FSX/R input from CLKX/R low	CLKX/R ext	9	ns
			CLKX/R int	0	
12	$t_{su}(FSX-CH)$	Setup time, external FSX before CLKX	CLKX ext	$-[t_c(H) - 8]^\dagger$ $[t_c(SCK)/2] - 10^\dagger$	ns
			CLKX int	$[t_c(H) - 21]^\dagger$ $t_c(SCK)/2^\dagger$	
13	$t_d(CH-DX)V$	Delay time, CLKX to first DX bit, FSX precedes CLKX high	CLKX ext	30^\dagger	ns
			CLKX int	18^\dagger	
14	$t_d(FSX-DX)V$	Delay time, FSX to first DX bit, CLKX precedes FSX		30^\dagger	ns
15	$t_d(CHH-DXZ)$	Delay time, CLKX high to DX high impedance following last data bit		17^\dagger	ns

† This value is characterized but not tested



serial-port timing parameters (see Figure 24 and Figure 25) (continued)

NO.			'320C30-50		UNIT
			MIN	MAX	
1	$t_d(H1H-SCK)$	Delay time, H1 high to internal CLKX/R	10		ns
2	$t_c(SCK)$	Cycle time, CLKX/R	$t_c(H) \times 2.6$ $t_c(H) \times 2$	$t_c(H) \times 2^{32}$	ns
3	$t_w(SCK)$	Pulse duration, CLKX/R high/low	CLKX/R ext	$t_c(H)+10$	ns
			CLKX/R int	$[t_c(SCK)/2]-5$ $[t_c(SCK)/2]+5$	
4	$t_r(SCK)$	Rise time, CLKX/R	6		ns
5	$t_f(SCK)$	Fall time, CLKX/R	6		ns
6	$t_d(CH-DX)$	Delay time, CLKX to DX valid	CLKX ext	24	ns
			CLKX int	16	
7	$t_{su}(DR-CLKRL)$	Setup time, DR before CLKR low	CLKR ext	9	ns
			CLKR int	17	
8	$t_h(CLKRL-DR)$	Hold time, DR from CLKR low	CLKR ext	7	ns
			CLKR int	0	
9	$t_d(CH-FSX)$	Delay time, CLKX to internal FSX high/low	CLKX ext	22	ns
			CLKX int	15	
10	$t_{su}(FSR-CLKRL)$	Setup time, FSR before CLKR low	CLKR ext	7	ns
			CLKR int	7	
11	$t_h(SCKL-FS)$	Hold time, FSX/R input from CLKX/R low	CLKX/R ext	7	ns
			CLKX/R int	0	
12	$t_{su}(FSX-CH)$	Setup time, external FSX before CLKX	CLKX ext	$-[t_c(H)-8]^\dagger$ $[t_c(SCK)/2]-10^\dagger$	ns
			CLKX int	$[t_c(H)-21]^\dagger$ $t_c(SCK)/2^\dagger$	
13	$t_d(CH-DX)V$	Delay time, CLKX to first DX bit, FSX precedes CLKX high	CLKX ext	24^\dagger	ns
			CLKX int	14^\dagger	
14	$t_d(FSX-DX)V$	Delay time, FSX to first DX bit, CLKX precedes FSX	24^\dagger		ns
15	$t_d(CHH-DXZ)$	Delay time, CLKX high to DX high impedance following last data bit	14^\dagger		ns

† This value is characterized but not tested

data-rate timing modes

Unless otherwise indicated, the data-rate timings shown in Figure 24 and Figure 25 are valid for all serial-port modes, including handshake. See serial-port timing parameter tables.

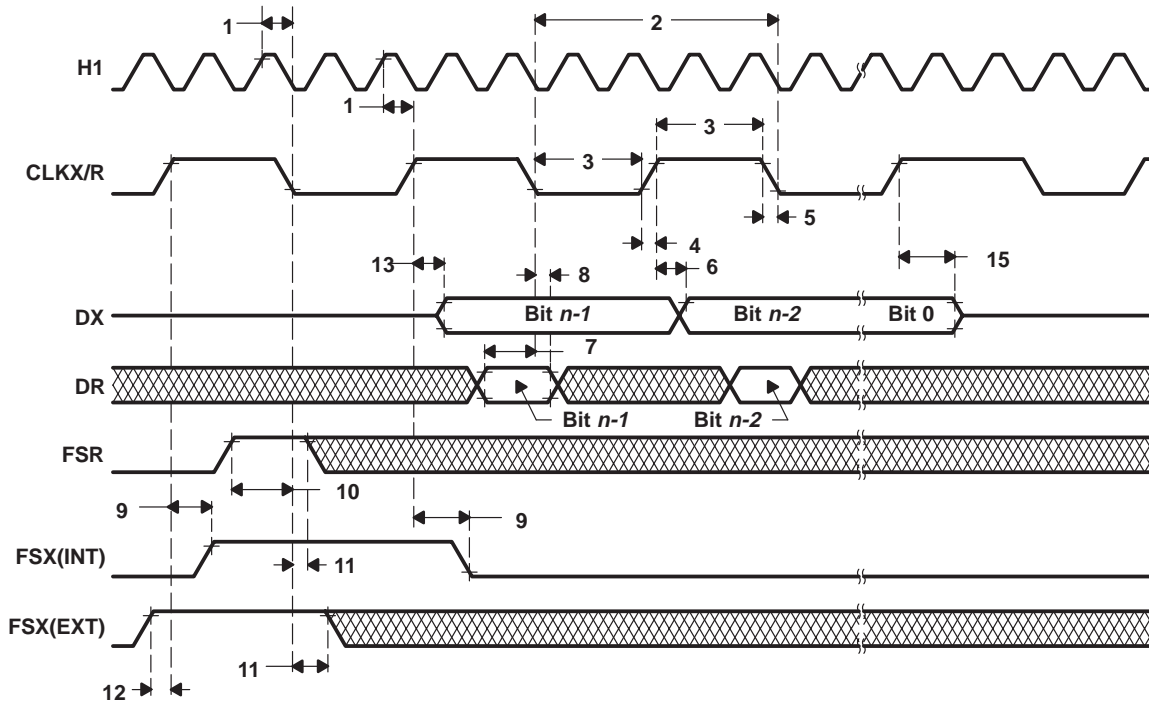

- NOTES: A. Timing diagrams show operations with CLKXP = CLKRP = FSXP = FSRP = 0.
B. Timing diagrams depend on the length of the serial port word, where $n = 8, 16, 24,$ or 32 bits, respectively.

Figure 24. Timing for Fixed Data-Rate Mode

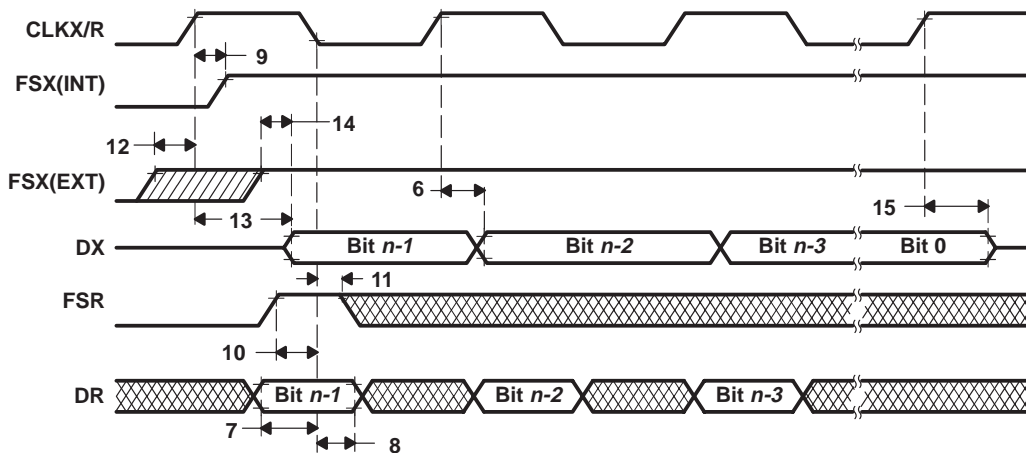

- NOTES: A. Timing diagrams show operation with CLKXP = CLKRP = FSXP = FSRP = 0.
B. Timing diagrams depend on the length of the serial-port word, where $n = 8, 16, 24,$ or 32 bits, respectively.
C. The timings that are not specified expressly for the variable data-rate mode are the same as those that are specified for the fixed data-rate mode.

Figure 25. Timing for Variable Data-Rate Mode

HOLD timing

$\overline{\text{HOLD}}$ is an asynchronous input that can be asserted at any time during a clock cycle. If the specified timings are met, the exact sequence shown in Figure 26 occurs; otherwise, an additional delay of one clock cycle is possible.

The “timing parameters for $\overline{\text{HOLD}}/\overline{\text{HOLDA}}$ ” table defines the timing parameters for the $\overline{\text{HOLD}}$ and $\overline{\text{HOLDA}}$ signals. The numbers shown in Figure 26 correspond with those in the NO. column of the table.

The NOHOLD bit of the primary bus control register overrides the $\overline{\text{HOLD}}$ signal. When this bit is set, the device comes out of hold and prevents future hold cycles.

Asserting $\overline{\text{HOLD}}$ prevents the processor from accessing the primary bus. Program execution continues until a read from or a write to the primary bus is requested. In certain circumstances, the first write is pending, thus allowing the processor to continue until a second write is encountered.

HOLD timing (continued)

timing parameters for $\overline{\text{HOLD}}/\overline{\text{HOLDA}}$ (see Figure 26)

NO.		'C30-27		'C30-33		'C30-40		'C30-50		UNIT
		MIN	MAX	MIN	MAX	MIN	MAX	MIN	MAX	
1	$t_{su}(\overline{\text{HOLD}}\text{-H1L})$	Setup time, $\overline{\text{HOLD}}$ before H1 low		19		15		13		ns
3	$t_v(\text{H1L}\text{-HOLDA})$	Valid time, $\overline{\text{HOLDA}}$ after H1 low		0 \dagger 14		0 \dagger 10		0 \dagger 9		ns
4	$t_w(\overline{\text{HOLD}}\dagger)$	Pulse duration, $\overline{\text{HOLD}}$ low		2 $t_{c(H)}$		2 $t_{c(H)}$		2 $t_{c(H)}$		ns
6	$t_w(\overline{\text{HOLDA}})$	Pulse duration, $\overline{\text{HOLDA}}$ low		$t_{c(H)}\text{-}5\dagger$		$t_{c(H)}\text{-}5\dagger$		$t_{c(H)}\text{-}5\dagger$		ns
7	$t_d(\text{H1L}\text{-SH})\overline{\text{HOLD}}$	Delay time, H1 low to (M)S and IOS high for a $\overline{\text{HOLD}}$		0 \S 13		0 \S 10		0 \S 9		ns
8	$t_{dis}(\text{H1L}\text{-S})Z$	Disable time, H1 low to (M)S and IOS in the high-impedance state		0 \S 13 \dagger		0 \S 10 \dagger		0 \S 9 \dagger		ns
9	$t_{en}(\text{H1L}\text{-S})$	Enable time, H1 low to (M)S and IOS (active)		0 \S 13		0 \S 10		0 \S 9		ns
10	$t_{dis}[\text{H1L}\text{-}(X)\overline{\text{RW}}]Z$	Disable time, H1 low to (X)R/W in the high-impedance state		0 \dagger 13 \dagger		0 \dagger 10 \dagger		0 \dagger 9 \dagger		ns
11	$t_{en}[\text{H1L}\text{-}(X)\overline{\text{RW}}]$	Enable time, H1 low to (X)R/W (active)		0 \dagger 13		0 \dagger 10		0 \dagger 9		ns
12	$t_{dis}[\text{H1L}\text{-}(X)A]$	Disable time, H1 low to (X)A in the high-impedance state		0 \S 13 \dagger		0 \S 10 \dagger		0 \S 10 \dagger		ns
13	$t_{en}[\text{H1L}\text{-}(X)A]$	Enable time, H1 low to (X)A (valid)		0 \S 19		0 \S 15		0 \S 13		ns
16	$t_{dis}[\text{H1H}\text{-}(X)D]Z$	Disable time, H1 high to (X)D in the high-impedance state		0 \S 13 \dagger		0 \S 10 \dagger		0 \S 9 \dagger		ns

\dagger This value is characterized but not tested

\ddagger $\overline{\text{HOLD}}$ is an asynchronous input and can be asserted at any point during a clock cycle. If the specified timings are met, the exact sequence shown occurs; otherwise, an additional delay of one clock cycle is possible.

\S Not tested

HOLD timing (continued)

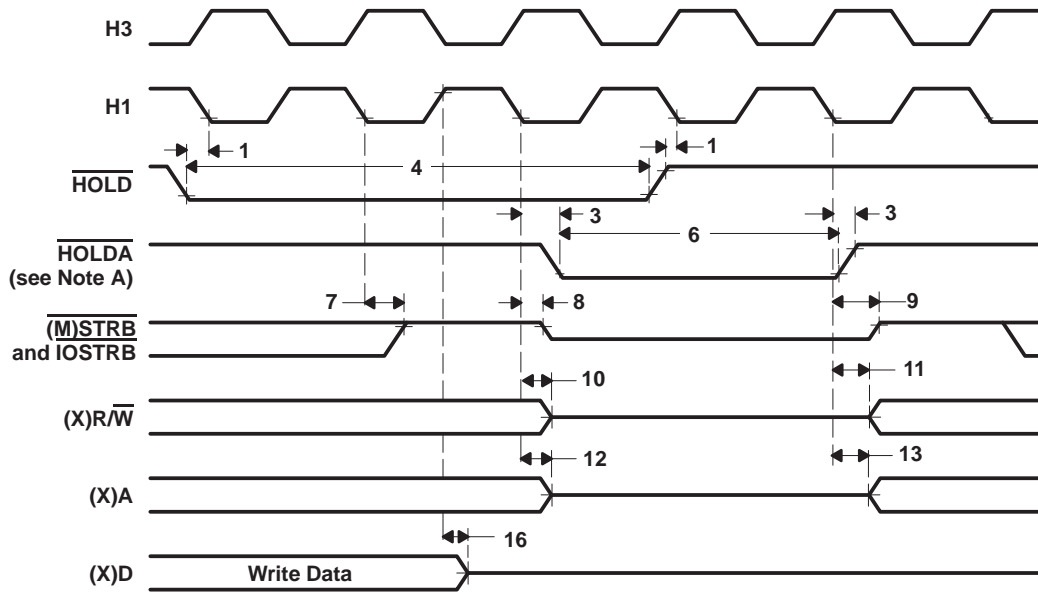

NOTE A: $\overline{\text{HOLDA}}$ goes low in response to $\overline{\text{HOLD}}$ going low and continues to remain low until one H1 cycle after $\overline{\text{HOLD}}$ goes back high.

Figure 26. Timing for $\overline{\text{HOLD}}/\overline{\text{HOLDA}}$

TMS320C30 DIGITAL SIGNAL PROCESSOR

SPRS032A – APRIL 1996 – REVISED JUNE 1997

general-purpose I/O timing

Peripheral pins include CLKX0/1, CLKR0/1, DX0/1, DR0/1, FSX0/1, FSR0/1, and TCLK0/1. The contents of the internal-control registers associated with each peripheral define the modes for these pins.

peripheral pin I/O timing

The following table defines peripheral pin general-purpose I/O timing parameters. The numbers shown in Figure 27 correspond with those in the NO. column of the table below.

timing parameters for peripheral pin general-purpose I/O (see Note 7 and Figure 27)

NO.		'C30-27		'C30-33		'C30-40		'C30-50		UNIT
		MIN	MAX	MIN	MAX	MIN	MAX	MIN	MAX	
1	$t_{su}(GPIO-H1L)$ Setup time, general-purpose input before H1 low	15		12		10		9		ns
2	$t_h(H1L-GPIO)$ Hold time, general-purpose input after H1 low	0		0		0		0		ns
3	$t_d(H1H-GPIO)$ Delay time, general-purpose output after H1 high		19		15		13		10	ns

NOTE 7: Peripheral pins include CLKX0/1, CLKR0/1, DX0/1, DR0/1, FSX0/1, FSR0/1, and TCLK0/1. The modes of these pins are defined by the contents of internal control registers associated with each peripheral.

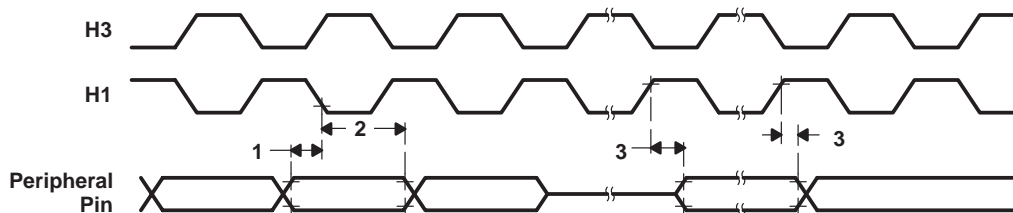

Figure 27. Timing for Peripheral Pin General-Purpose I/O

changing the peripheral pin I/O modes

The following tables show the timing parameters for changing the peripheral pin from a general-purpose output pin to a general-purpose input pin and the reverse. The numbers shown in Figure 28 and Figure 29 correspond to those shown in the NO. column of the following tables.

timing parameters for peripheral pin changing from general-purpose output to input mode (see Note 7 and Figure 28)

NO.		'C30-27		'C30-33		'C30-40		'C30-50		UNIT
		MIN	MAX	MIN	MAX	MIN	MAX	MIN	MAX	
1	$t_h(H1H-GPIO)$ Hold time, peripheral pin after H1 high		19		15		13		10	ns
2	$t_{su}(GPIO-H1L)$ Setup time, peripheral pin before H1 low	13		10		9		9		ns
3	$t_h(H1L-GPIO)$ Hold time, peripheral pin after H1 low	0		0		0		0		ns

NOTE 7: Peripheral pins include CLKX0/1, CLKR0/1, DX0/1, DR0/1, FSX0/1, FSR0/1, and TCLK0/1. The modes of these pins are defined by the contents of internal control registers associated with each peripheral.

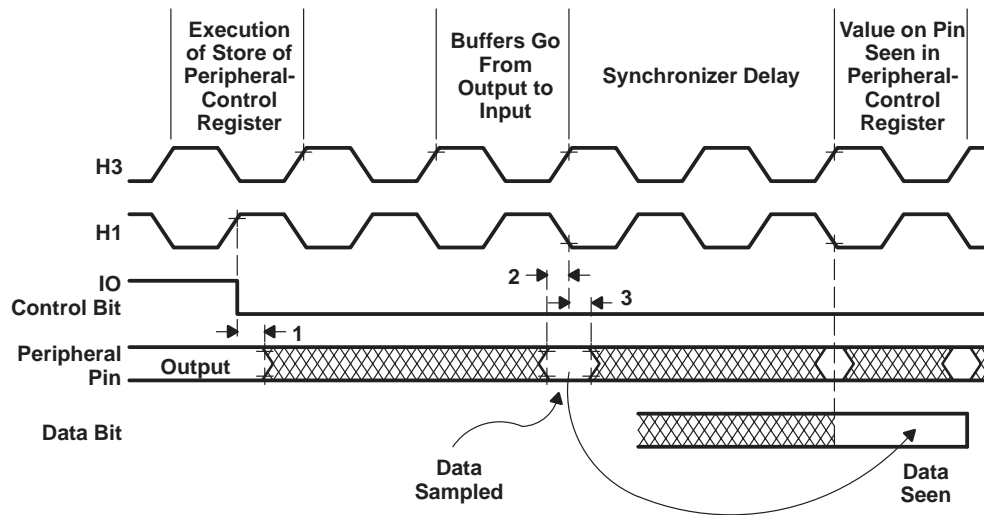

Figure 28. Timing for Change of Peripheral Pin From General-Purpose Output to Input Mode

TMS320C30 DIGITAL SIGNAL PROCESSOR

SPRS032A – APRIL 1996 – REVISED JUNE 1997

timing parameters for peripheral pin changing from general-purpose input to output mode (see Note 7 and Figure 29)

NO.		'C30-27		'C30-33		'C30-40		'C30-50		UNIT
		MIN	MAX	MIN	MAX	MIN	MAX	MIN	MAX	
1	$t_d(H1H-GPIO)$ Delay time, H1 high to peripheral pin switching from input to output		19		15		13		10	ns

NOTE 7: Peripheral pins include CLKX0/1, CLKR0/1, DX0/1, DR0/1, FSX0/1, FSR0/1, and TCLK0/1. The modes of these pins are defined by the contents of internal-control registers associated with each peripheral.

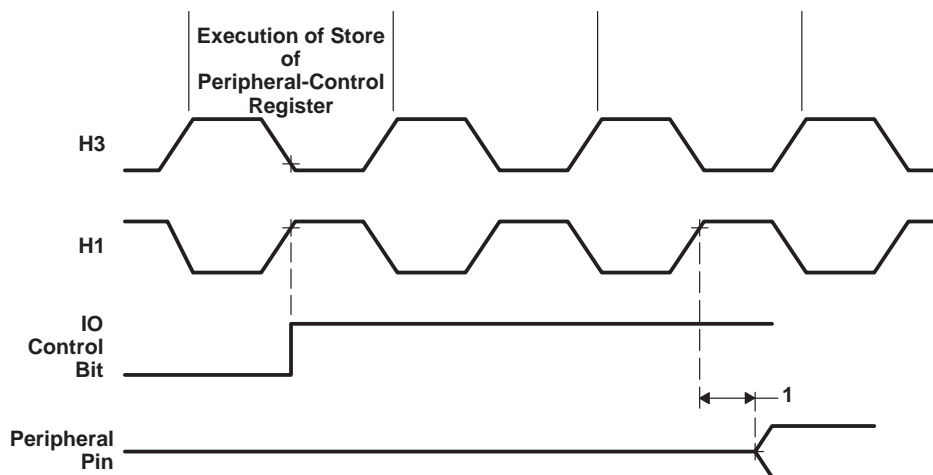

Figure 29. Timing for Change of Peripheral Pin From General-Purpose Input to Output Mode

timer pin (TCLK0 and TCLK1) timing

Valid logic-level periods and polarity are specified by the contents of the internal control registers.

The following tables define the timing parameters for the timer pin. The numbers shown in Figure 30 correspond with those in the NO. column of the tables below.

timing parameters for timer pin (TCLK0 and TCLK1) (see Figure 30)†

NO.			'C30-27†		'C30-33†		UNIT	
			MIN	MAX	MIN	MAX		
1	$t_{su}(TCLK-H1L)$	Setup time, TCLK ext before H1 low	TCLK ext	15		12	ns	
2	$t_h(H1L-TCLK)$	Hold time, TCLK ext after H1 low	TCLK ext	0		0	ns	
3	$t_d(H1H-TCLK)$	Delay time, H1 high to TCLK int valid	TCLK int		13	10	ns	
4	$t_c(TCLK)$	Cycle time, TCLK	TCLK ext	$t_c(H) \times 2.6$		$t_c(H) \times 2.6$		ns
			TCLK int	$t_c(H) \times 2$	$t_c(H) \times 2^{32} \ddagger$	$t_c(H) \times 2$	$t_c(H) \times 2^{32} \ddagger$	
5	$t_w(TCLK)$	Pulse duration, TCLK high/low	TCLK ext	$t_c(H) + 12$		$t_c(H) + 12$		ns
			TCLK int	$[t_c(TCLK)/2] - 15$	$[t_c(TCLK)/2] + 5$	$[t_c(TCLK)/2] - 15$	$[t_c(TCLK)/2] + 5$	

NO.			'C30-40†		'C30-50†		UNIT	
			MIN	MAX	MIN	MAX		
1	$t_{su}(TCLK-H1L)$	Setup time, TCLK ext before H1 low	TCLK ext	10		8	ns	
2	$t_h(H1L-TCLK)$	Hold time, TCLK ext after H1 low	TCLK ext	0		0	ns	
3	$t_d(H1H-TCLK)$	Delay time, H1 high to TCLK int valid	TCLK int		9	9	ns	
4	$t_c(TCLK)$	Cycle time, TCLK	TCLK ext	$t_c(H) \times 2.6$		$t_c(H) \times 2.6$		ns
			TCLK int	$t_c(H) \times 2$	$t_c(H) \times 2^{32} \ddagger$	$t_c(H) \times 2$	$t_c(H) \times 2^{32} \ddagger$	
5	$t_w(TCLK)$	Pulse duration, TCLK high/low	TCLK ext	$t_c(H) + 10$		$t_c(H) + 10$		ns
			TCLK int	$[t_c(TCLK)/2] - 5$	$[t_c(TCLK)/2] + 5$	$[t_c(TCLK)/2] - 5$	$[t_c(TCLK)/2] + 5$	

† Timing parameters 1 and 2 are applicable for a synchronous input clock. Timing parameters 4 and 5 are applicable for an asynchronous input clock.

‡ Assured by design but not tested

timer pin (TCLK0 and TCLK1) timing (continued)

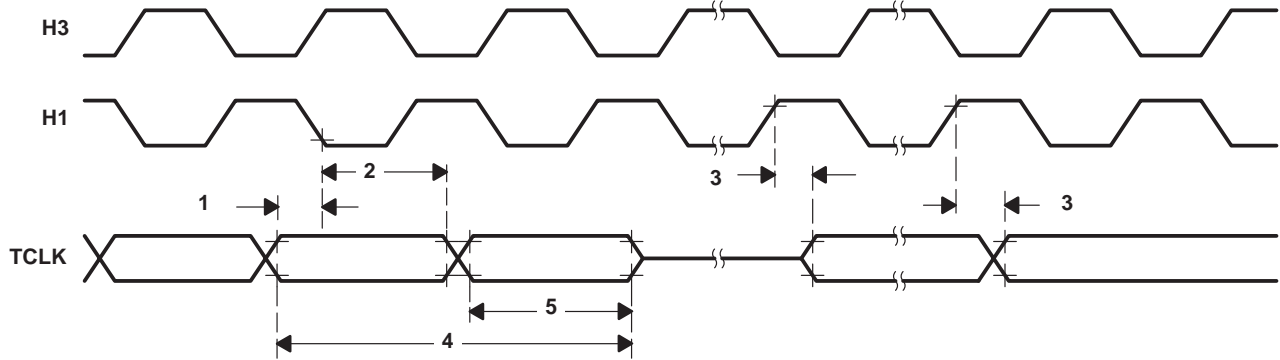

Figure 30. Timing for Timer Pin

$\overline{\text{SHZ}}$ pin timing

The following table defines the timing parameter for the $\overline{\text{SHZ}}$ pin. The number shown in Figure 31 corresponds with that in the NO. column of the table below.

timing parameters for $\overline{\text{SHZ}}$ pin (see Figure 31)

NO.		'C30		UNIT
		MIN	MAX	
1	$t_{\text{dis}}(\overline{\text{SHZ}})$ Disable time, $\overline{\text{SHZ}}$ low to all outputs, I/O pins disabled (high impedance)	0†	2P‡	ns

† Characterized but not tested

‡ P = $t_c(\text{Cl})$

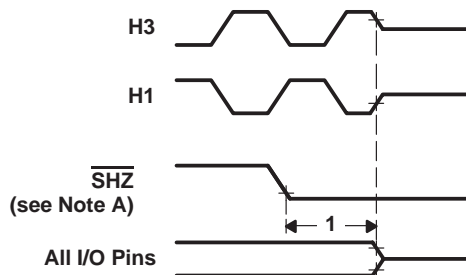

NOTE A: Enabling $\overline{\text{SHZ}}$ destroys TMS320C30 register and memory contents. Assert $\overline{\text{SHZ}} = 1$ and reset the TMS320C30 to restore it to a known condition.

Figure 31. Timing for $\overline{\text{SHZ}}$

PACKAGING INFORMATION

Orderable Device	Status (1)	Package Type	Package Drawing	Pins	Package Qty	Eco Plan (2)	Lead/Ball Finish (6)	MSL Peak Temp (3)	Op Temp (°C)	Device Marking (4/5)	Samples
TMS320C30GEL	OBSOLETE	CPGA	GE	181		TBD	Call TI	Call TI	0 to 70		
TMS320C30GEL27	OBSOLETE	CPGA	GB	181		TBD	Call TI	Call TI			
TMS320C30GEL40	OBSOLETE	CPGA	GE	181		TBD	AU	N / A for Pkg Type	0 to 70	40	
TMS320C30GEL50	OBSOLETE	CPGA	GE	181		TBD	AU	N / A for Pkg Type		50	
TMS320C30GELSD	NRND	CPGA	GE	181	21	TBD	AU	N / A for Pkg Type	0 to 70	TMS320C30GEL SD	

(1) The marketing status values are defined as follows:

ACTIVE: Product device recommended for new designs.

LIFEBUY: TI has announced that the device will be discontinued, and a lifetime-buy period is in effect.

NRND: Not recommended for new designs. Device is in production to support existing customers, but TI does not recommend using this part in a new design.

PREVIEW: Device has been announced but is not in production. Samples may or may not be available.

OBSOLETE: TI has discontinued the production of the device.

(2) Eco Plan - The planned eco-friendly classification: Pb-Free (RoHS), Pb-Free (RoHS Exempt), or Green (RoHS & no Sb/Br) - please check <http://www.ti.com/productcontent> for the latest availability information and additional product content details.

TBD: The Pb-Free/Green conversion plan has not been defined.

Pb-Free (RoHS): TI's terms "Lead-Free" or "Pb-Free" mean semiconductor products that are compatible with the current RoHS requirements for all 6 substances, including the requirement that lead not exceed 0.1% by weight in homogeneous materials. Where designed to be soldered at high temperatures, TI Pb-Free products are suitable for use in specified lead-free processes.

Pb-Free (RoHS Exempt): This component has a RoHS exemption for either 1) lead-based flip-chip solder bumps used between the die and package, or 2) lead-based die adhesive used between the die and leadframe. The component is otherwise considered Pb-Free (RoHS compatible) as defined above.

Green (RoHS & no Sb/Br): TI defines "Green" to mean Pb-Free (RoHS compatible), and free of Bromine (Br) and Antimony (Sb) based flame retardants (Br or Sb do not exceed 0.1% by weight in homogeneous material)

(3) MSL, Peak Temp. - The Moisture Sensitivity Level rating according to the JEDEC industry standard classifications, and peak solder temperature.

(4) There may be additional marking, which relates to the logo, the lot trace code information, or the environmental category on the device.

(5) Multiple Device Markings will be inside parentheses. Only one Device Marking contained in parentheses and separated by a "-" will appear on a device. If a line is indented then it is a continuation of the previous line and the two combined represent the entire Device Marking for that device.

(6) Lead/Ball Finish - Orderable Devices may have multiple material finish options. Finish options are separated by a vertical ruled line. Lead/Ball Finish values may wrap to two lines if the finish value exceeds the maximum column width.

Important Information and Disclaimer: The information provided on this page represents TI's knowledge and belief as of the date that it is provided. TI bases its knowledge and belief on information provided by third parties, and makes no representation or warranty as to the accuracy of such information. Efforts are underway to better integrate information from third parties. TI has taken and continues to take reasonable steps to provide representative and accurate information but may not have conducted destructive testing or chemical analysis on incoming materials and chemicals. TI and TI suppliers consider certain information to be proprietary, and thus CAS numbers and other limited information may not be available for release.

In no event shall TI's liability arising out of such information exceed the total purchase price of the TI part(s) at issue in this document sold by TI to Customer on an annual basis.

OTHER QUALIFIED VERSIONS OF TMS320C30 :

- Catalog: [SM320C30](#)
- Military: [SMJ320C30](#)

NOTE: Qualified Version Definitions:

- Catalog - TI's standard catalog product
- Military - QML certified for Military and Defense Applications

IMPORTANT NOTICE

Texas Instruments Incorporated and its subsidiaries (TI) reserve the right to make corrections, enhancements, improvements and other changes to its semiconductor products and services per JESD46, latest issue, and to discontinue any product or service per JESD48, latest issue. Buyers should obtain the latest relevant information before placing orders and should verify that such information is current and complete. All semiconductor products (also referred to herein as "components") are sold subject to TI's terms and conditions of sale supplied at the time of order acknowledgment.

TI warrants performance of its components to the specifications applicable at the time of sale, in accordance with the warranty in TI's terms and conditions of sale of semiconductor products. Testing and other quality control techniques are used to the extent TI deems necessary to support this warranty. Except where mandated by applicable law, testing of all parameters of each component is not necessarily performed.

TI assumes no liability for applications assistance or the design of Buyers' products. Buyers are responsible for their products and applications using TI components. To minimize the risks associated with Buyers' products and applications, Buyers should provide adequate design and operating safeguards.

TI does not warrant or represent that any license, either express or implied, is granted under any patent right, copyright, mask work right, or other intellectual property right relating to any combination, machine, or process in which TI components or services are used. Information published by TI regarding third-party products or services does not constitute a license to use such products or services or a warranty or endorsement thereof. Use of such information may require a license from a third party under the patents or other intellectual property of the third party, or a license from TI under the patents or other intellectual property of TI.

Reproduction of significant portions of TI information in TI data books or data sheets is permissible only if reproduction is without alteration and is accompanied by all associated warranties, conditions, limitations, and notices. TI is not responsible or liable for such altered documentation. Information of third parties may be subject to additional restrictions.

Resale of TI components or services with statements different from or beyond the parameters stated by TI for that component or service voids all express and any implied warranties for the associated TI component or service and is an unfair and deceptive business practice. TI is not responsible or liable for any such statements.

Buyer acknowledges and agrees that it is solely responsible for compliance with all legal, regulatory and safety-related requirements concerning its products, and any use of TI components in its applications, notwithstanding any applications-related information or support that may be provided by TI. Buyer represents and agrees that it has all the necessary expertise to create and implement safeguards which anticipate dangerous consequences of failures, monitor failures and their consequences, lessen the likelihood of failures that might cause harm and take appropriate remedial actions. Buyer will fully indemnify TI and its representatives against any damages arising out of the use of any TI components in safety-critical applications.

In some cases, TI components may be promoted specifically to facilitate safety-related applications. With such components, TI's goal is to help enable customers to design and create their own end-product solutions that meet applicable functional safety standards and requirements. Nonetheless, such components are subject to these terms.

No TI components are authorized for use in FDA Class III (or similar life-critical medical equipment) unless authorized officers of the parties have executed a special agreement specifically governing such use.

Only those TI components which TI has specifically designated as military grade or "enhanced plastic" are designed and intended for use in military/aerospace applications or environments. Buyer acknowledges and agrees that any military or aerospace use of TI components which have **not** been so designated is solely at the Buyer's risk, and that Buyer is solely responsible for compliance with all legal and regulatory requirements in connection with such use.

TI has specifically designated certain components as meeting ISO/TS16949 requirements, mainly for automotive use. In any case of use of non-designated products, TI will not be responsible for any failure to meet ISO/TS16949.

Products

Audio	www.ti.com/audio
Amplifiers	amplifier.ti.com
Data Converters	dataconverter.ti.com
DLP® Products	www.dlp.com
DSP	dsp.ti.com
Clocks and Timers	www.ti.com/clocks
Interface	interface.ti.com
Logic	logic.ti.com
Power Mgmt	power.ti.com
Microcontrollers	microcontroller.ti.com
RFID	www.ti-rfid.com
OMAP Applications Processors	www.ti.com/omap
Wireless Connectivity	www.ti.com/wirelessconnectivity

Applications

Automotive and Transportation	www.ti.com/automotive
Communications and Telecom	www.ti.com/communications
Computers and Peripherals	www.ti.com/computers
Consumer Electronics	www.ti.com/consumer-apps
Energy and Lighting	www.ti.com/energy
Industrial	www.ti.com/industrial
Medical	www.ti.com/medical
Security	www.ti.com/security
Space, Avionics and Defense	www.ti.com/space-avionics-defense
Video and Imaging	www.ti.com/video

TI E2E Community

e2e.ti.com