

TPA2005D1-Q1 1.4-W Mono Filter-Free Class-D Audio Power Amplifier

1 Features

- Qualified for Automotive Applications
- AEC-Q100 Qualified With the Following Results:
 - Device Temperature Grade 3 (DRB and DGN package non T-suffix): -40°C to 85°C Ambient Operating Temperature Range
 - Device Temperature Grade 2 (DGN package T-suffix): -40°C to 105°C Ambient Operating Temperature Range
 - Device HBM Classification Level 2
 - Device CDM Classification Level C5
- 1.4 W Into 8 Ω From a 5-V Supply at THD = 10% (Typ)
- Maximum Battery Life and Minimum Heat
 - Efficiency With an 8- Ω Speaker:
 - 84% at 400 mW
 - 79% at 100 mW
 - 2.8-mA Quiescent Current
 - 0.5- μ A Shutdown Current
- Only Three External Components
 - Optimized PWM Output Stage Eliminates LC Output Filter
 - Internally Generated 250-kHz Switching Frequency Eliminates Capacitor and Resistor
 - Improved PSRR (-71 dB at 217 Hz) and Wide Supply Voltage (2.5 V to 5.5 V) Eliminates Need for a Voltage Regulator
 - Fully Differential Design Reduces RF Rectification and Eliminates Bypass Capacitor
 - Improved CMRR Eliminates Two Input Coupling Capacitors
- Space-Saving Packages
 - 3 mm x 3 mm SON package (DRB)
 - 3 mm x 5 mm MSOP PowerPAD™ Package (DGN)

2 Applications

- Cluster
- Head Unit
- Telematics
- Emergency Call (eCall)
- Noise Generator

3 Description

The TPA2005D1-Q1 is a 1.4-W high-efficiency filter-free class-D audio power amplifier in a SON or MSOP package that requires only three external components.

Features like 84% efficiency, -71-dB PSRR at 217 Hz, improved RF-rectification immunity, and 15-mm² total PCB area make TPA2005D1-Q1 ideal for low-power audio applications in infotainment and cluster.

The device allows for independent gain control by summing the signals from each function while minimizing noise to only 48 μ V_{RMS}. Additionally, the TPA2005D1-Q1 offers fast start-up time of 9ms with minimal pop and has short circuit and thermal protection.

Device Information⁽¹⁾

PART NUMBER	PACKAGE	BODY SIZE (NOM)
TPA2005D1-Q1	MSOP-PowerPAD (8)	3.00 mm x 3.00 mm
	SON (8)	3.00 mm x 3.00 mm

(1) For all available packages, see the orderable addendum at the end of the datasheet.

Application Circuit

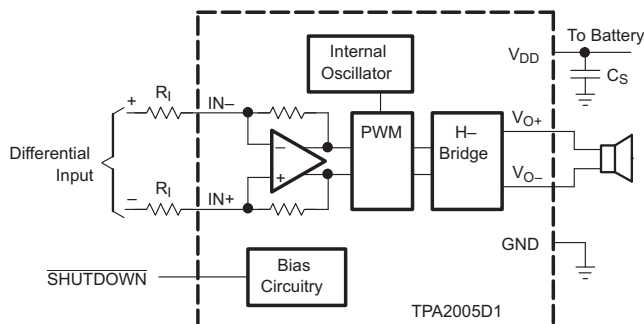

Table of Contents

1 Features	1	9.2 Functional Block Diagram	12
2 Applications	1	9.3 Feature Description	12
3 Description	1	9.4 Device Functional Modes	16
4 Revision History	2	10 Application and Implementation	19
5 Device Comparison Table	3	10.1 Application Information	19
6 Pin Configuration and Functions	3	10.2 Typical Application	19
7 Specifications	4	11 Power Supply Recommendations	23
7.1 Absolute Maximum Ratings	4	11.1 Power Supply Decoupling Capacitors	23
7.2 ESD Ratings	4	12 Layout	24
7.3 Recommended Operating Conditions	4	12.1 Layout Guidelines	24
7.4 Thermal Information	4	12.2 Layout Example	25
7.5 Electrical Characteristics	5	13 Device and Documentation Support	26
7.6 Operating Characteristics	5	13.1 Community Resource	26
7.7 Typical Characteristics	6	13.2 Trademarks	26
8 Parameter Measurement Information	11	13.3 Electrostatic Discharge Caution	26
9 Detailed Description	12	13.4 Glossary	26
9.1 Overview	12	14 Mechanical, Packaging, and Orderable Information	26

4 Revision History

NOTE: Page numbers for previous revisions may differ from page numbers in the current version.

Changes from Revision C (March 2010) to Revision D	Page
• Added <i>Applications</i> , <i>ESD Rating</i> table, <i>Feature Description</i> section, <i>Device Functional Modes</i> , <i>Application and Implementation</i> section, <i>Power Supply Recommendations</i> section, <i>Layout</i> section, <i>Device and Documentation Support</i> section, and <i>Mechanical, Packaging, and Orderable Information</i> section.	1
• Deleted Ordering Information table. See POA in the back of document.	1
• Added R_L Load resistance, to the Abs Max Ratings Table	4
• Changed Storage temperature From: -65°C to 85°C To: -65°C to 150°C	4
• Deleted Dissipation Ratings table and added Thermal Information table.	4
• Updated <i>Efficiency and Thermal Information</i>	13

5 Device Comparison Table

DEVICE NUMBER	SPEAKER CHANNELS	SPEAKER AMP TYPE	OUTPUT POWER (W)	PSRR (dB)	SUPPLY MIN (V)	SUPPLY MAX (V)	PACKAGE FAMILY
TPA2005D1-Q1	Mono	Class D	1.4	75	2.5	5.5	MSOP-PowerPAD SON
TPA2000D1-Q1	Mono	Class D	2	77	2.7	5.5	TSSOP

6 Pin Configuration and Functions

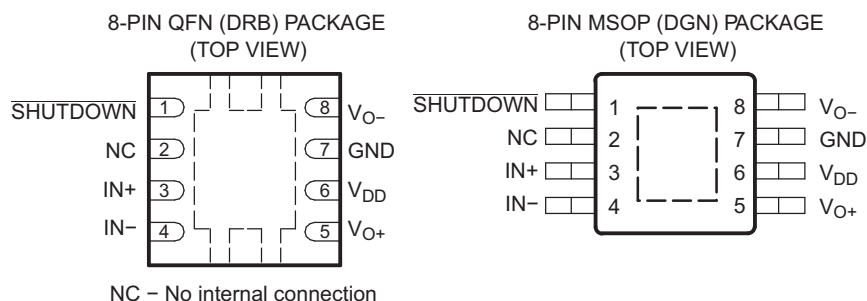

- The shaded terminals are used for electrical and thermal connections to the ground plane. All of the shaded terminals must be electrically connected to ground. No connect (NC) terminals still need a pad and trace.
- The thermal pad of the DRB and DGN packages must be electrically and thermally connected to a ground plane.

Pin Functions

PIN		I/O	DESCRIPTION
NAME	NO.		
IN-	4	I	Negative differential input
IN+	3	I	Positive differential input
V _{DD}	6	I	Power supply
V _{O+}	5	O	Positive BTL output
GND	7	I	High-current ground
V _{O-}	8	O	Negative BTL output
SHUTDOWN	1	I	Shutdown terminal (active low logic)
NC	2		No internal connection
Thermal Pad			Must be soldered to a grounded pad on the PCB.

7 Specifications

7.1 Absolute Maximum Ratings

 over operating free-air temperature range (unless otherwise noted)⁽¹⁾

		MIN	MAX	UNIT	
V _{DD}	Supply voltage ⁽²⁾	In active mode	–0.3	6	V
		In $\overline{\text{SHUTDOWN}}$ mode	–0.3	7	V
V _I	Input voltage	–0.3	V _{DD} + 0.3 V	V	
T _A	Operating free-air temperature	Non T-suffix	–40	85	°C
		T-suffix	–40	105	
T _J	Operating junction temperature	–40	150	°C	
R _L	Load resistance	2.5 ≤ V _{DD} ≤ 4.2 V	3.2 (Minimum)		Ω
		4.2 < V _{DD} ≤ 6 V	6.4 (Minimum)		Ω
T _{stg}	Storage temperature	–65	150	°C	

- (1) Stresses beyond those listed under *Absolute Maximum Ratings* may cause permanent damage to the device. These are stress ratings only, which do not imply functional operation of the device at these or any other conditions beyond those indicated under *Recommended Operating Conditions*. Exposure to absolute-maximum-rated conditions for extended periods may affect device reliability.
- (2) For the MSOP (DGN) package option, the maximum V_{DD} should be limited to 5 V if short-circuit protection is desired.

7.2 ESD Ratings

		VALUE	UNIT	
V _(ESD)	Electrostatic discharge	Human-body model (HBM), per AEC Q100-002 ⁽¹⁾	±2000	V
		Charged-device model (CDM), per AEC Q100-011	±1000	

- (1) AEC Q100-002 indicates that HBM stressing shall be in accordance with the ANSI/ESDA/JEDEC JS-001 specification.

7.3 Recommended Operating Conditions

		MIN	MAX	UNIT	
V _{DD}	Supply voltage	2.5	5.5	V	
V _{IH}	High-level input voltage	$\overline{\text{SHUTDOWN}}$	V _{DD}	V	
V _{IL}	Low-level input voltage	$\overline{\text{SHUTDOWN}}$	0.7	V	
R _I	Input resistor	Gain ≤ 20 V/V (26 dB)		kΩ	
V _{IC}	Common-mode input voltage range	V _{DD} = 2.5 V, 5.5 V, CMRR ≤ –49 dB		V	
T _A	Operating free-air temperature	Non T-suffix	–40	85	°C
		T-suffix	–40	105	

7.4 Thermal Information

THERMAL METRIC ⁽¹⁾		TPA2005D1-Q1		UNIT
		DRB (SON)	DGN (MSOP PowerPAD)	
		8 PINS	8 PINS	
R _{θJA}	Junction-to-ambient thermal resistance	49.5	57	°C/W
R _{θJC(top)}	Junction-to-case (top) thermal resistance	62.1	53.8	°C/W
R _{θJB}	Junction-to-board thermal resistance	24.8	33.7	°C/W
ψ _{JT}	Junction-to-top characterization parameter	1.3	1.9	°C/W
ψ _{JB}	Junction-to-board characterization parameter	24.9	33.4	°C/W
R _{θJC(bot)}	Junction-to-case (bottom) thermal resistance	6.9	6.4	°C/W

- (1) For more information about traditional and new thermal metrics, see the *Semiconductor and IC Package Thermal Metrics* application report, [SPRA953](#).

7.5 Electrical Characteristics

 $T_A = -40^\circ\text{C}$ to 85°C (unless otherwise noted)

PARAMETER		TEST CONDITIONS	MIN	TYP	MAX	UNIT
$ V_{OS} $	Output offset voltage (measured differentially)	$V_I = 0\text{ V}$, $A_V = 2\text{ V/V}$, $V_{DD} = 2.5\text{ V}$ to 5.5 V			25	mV
PSRR	Power-supply rejection ratio	$V_{DD} = 2.5\text{ V}$ to 5.5 V		-75	-55	dB
CMRR	Common-mode rejection ratio	$V_{DD} = 2.5\text{ V}$ to 5.5 V , $V_{IC} = V_{DD}/2$ to 0.5 V , $V_{IC} = V_{DD}/2$ to $V_{DD} - 0.8\text{ V}$	$T_A = 25^\circ\text{C}$	-68	-49	dB
			$T_A = -40^\circ\text{C}$ to 85°C		-35	
$ I_{IH} $	High-level input current	$V_{DD} = 5.5\text{ V}$, $V_I = 5.8\text{ V}$			50	μA
$ I_{IL} $	Low-level input current	$V_{DD} = 5.5\text{ V}$, $V_I = 0.3\text{ V}$	$T_A = -40^\circ\text{C}$ to 85°C		4	μA
			$T_A = -40^\circ\text{C}$ to 105°C		12	
$I_{(Q)}$	Quiescent current	$V_{DD} = 5.5\text{ V}$, no load		3.4	4.5	mA
		$V_{DD} = 3.6\text{ V}$, no load		2.8		
		$V_{DD} = 2.5\text{ V}$, no load		2.2	3.2	
$I_{(SD)}$	Shutdown current	$V_{(SHUTDOWN)} = 0.8\text{ V}$, $V_{DD} = 2.5\text{ V}$ to 5.5 V	$T_A = -40^\circ\text{C}$ to 85°C	0.5	2	μA
			$T_A = -40^\circ\text{C}$ to 105°C			
$r_{DS(on)}$	Static drain-source on-state resistance	$V_{DD} = 2.5\text{ V}$		770		m Ω
		$V_{DD} = 3.6\text{ V}$		590		
		$V_{DD} = 5.5\text{ V}$		500		
	Output impedance in SHUTDOWN	$V_{(SHUTDOWN)} = 0.8\text{ V}$		>1		k Ω
$f_{(sw)}$	Switching frequency	$V_{DD} = 2.5\text{ V}$ to 5.5 V	200	250	300	kHz
	Gain		$2 \times \frac{142\text{ k}\Omega}{R_1}$	$2 \times \frac{150\text{ k}\Omega}{R_1}$	$2 \times \frac{158\text{ k}\Omega}{R_1}$	$\frac{\text{V}}{\text{V}}$

7.6 Operating Characteristics

 $T_A = 25^\circ\text{C}$, Gain = 2 V/V , $R_L = 8\ \Omega$ (unless otherwise noted)

PARAMETER		TEST CONDITIONS	MIN	TYP	MAX	UNIT
P_O	Output power	THD + N= 1%, $f = 1\text{ kHz}$, $R_L = 8\ \Omega$	$V_{DD} = 5\text{ V}$	1.18		W
			$V_{DD} = 3.6\text{ V}$	0.58		
			$V_{DD} = 2.5\text{ V}$	0.26		
		THD + N= 10%, $f = 1\text{ kHz}$, $R_L = 8\ \Omega$	$V_{DD} = 5\text{ V}$	1.45		W
			$V_{DD} = 3.6\text{ V}$	0.75		
			$V_{DD} = 2.5\text{ V}$	0.35		
THD+N	Total harmonic distortion plus noise	$P_O = 1\text{ W}$, $f = 1\text{ kHz}$, $R_L = 8\ \Omega$	$V_{DD} = 5\text{ V}$	0.18%		
		$P_O = 0.5\text{ W}$, $f = 1\text{ kHz}$, $R_L = 8\ \Omega$	$V_{DD} = 3.6\text{ V}$	0.19%		
		$P_O = 200\text{ mW}$, $f = 1\text{ kHz}$, $R_L = 8\ \Omega$	$V_{DD} = 2.5\text{ V}$	0.20%		
k_{SVR}	Supply ripple rejection ratio	$f = 217\text{ Hz}$, $V_{(RIPPLE)} = 200\text{ mV}_{pp}$, Inputs ac-grounded with $C_i = 2\ \mu\text{F}$	$V_{DD} = 3.6\text{ V}$	-71		dB
SNR	Signal-to-noise ratio	$P_O = 1\text{ W}$, $R_L = 8\ \Omega$	$V_{DD} = 5\text{ V}$	97		dB
V_n	Output voltage noise	$V_{DD} = 3.6\text{ V}$, $f = 20\text{ Hz}$ to 20 kHz , Inputs ac-grounded with $C_i = 2\ \mu\text{F}$	No weighting	48		μV_{RMS}
			A weighting	36		
CMRR	Common-mode rejection ratio	$V_{IC} = 1\text{ V}_{pp}$, $f = 217\text{ Hz}$	$V_{DD} = 3.6\text{ V}$	-63		dB
Z_i	Input impedance		142	150	158	k Ω
	Start-up time from shutdown		$V_{DD} = 3.6\text{ V}$	9		ms

7.7 Typical Characteristics

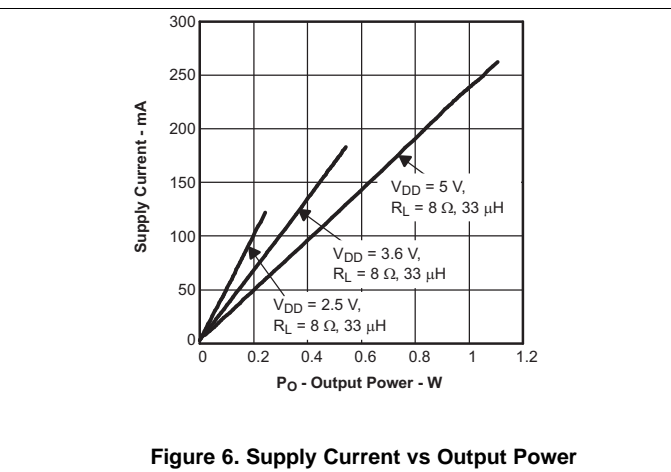
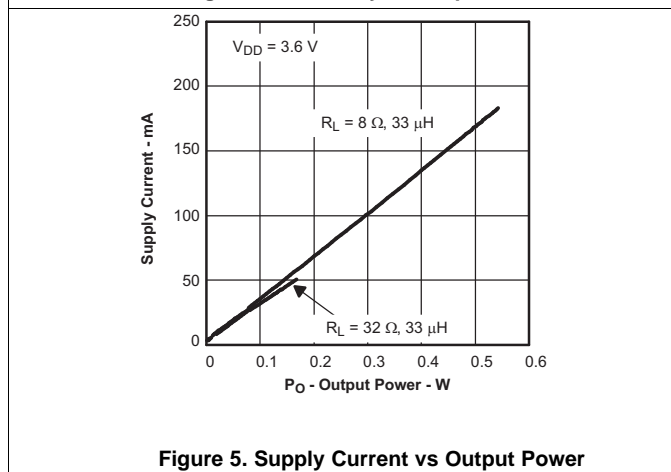
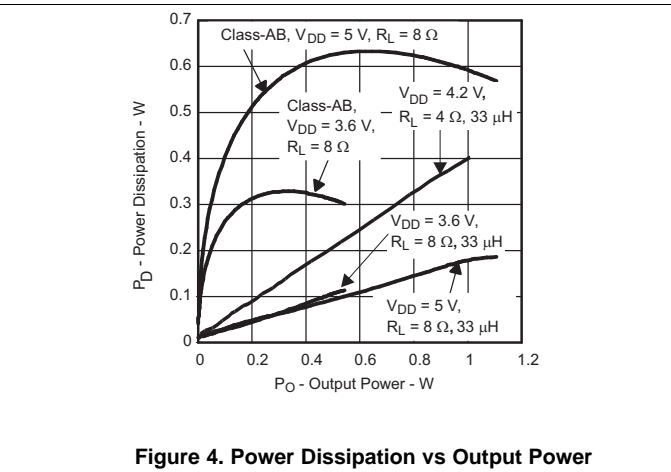
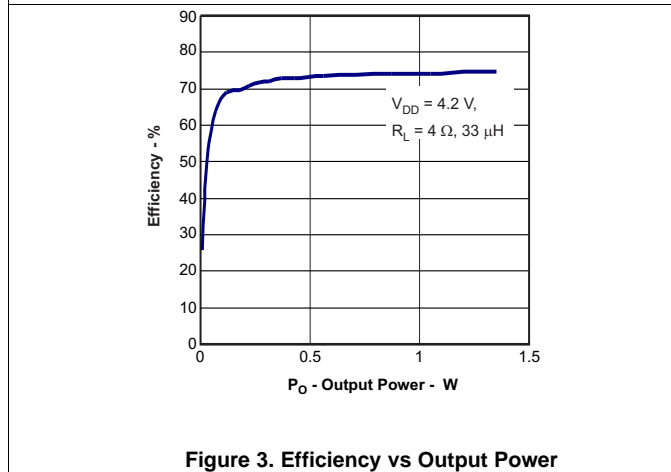
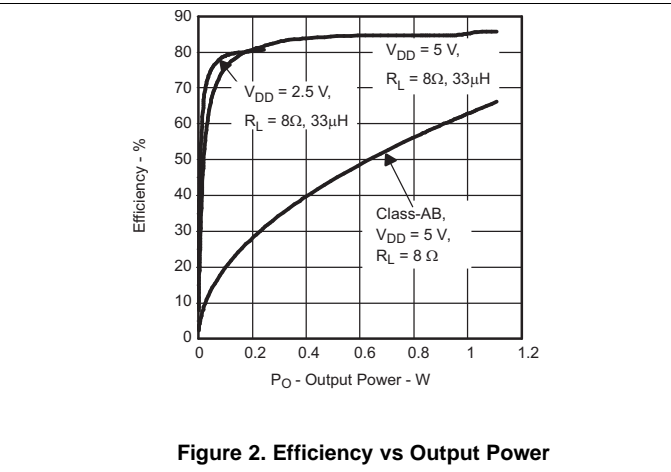
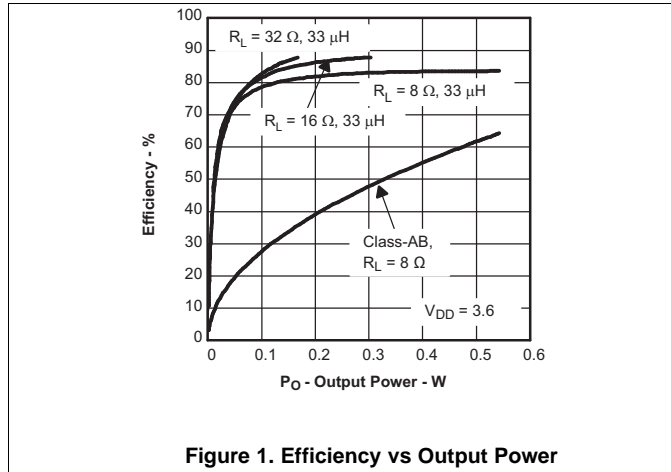

Typical Characteristics (continued)

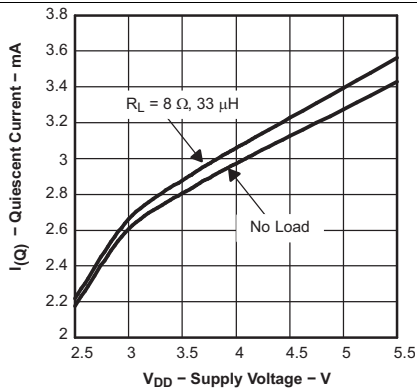

Figure 7. Quiescent Current vs Supply Voltage

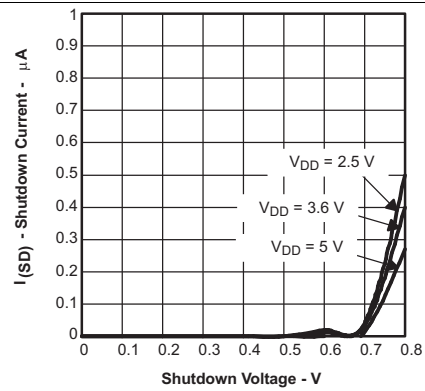

Figure 8. Shutdown Current vs Shutdown Voltage

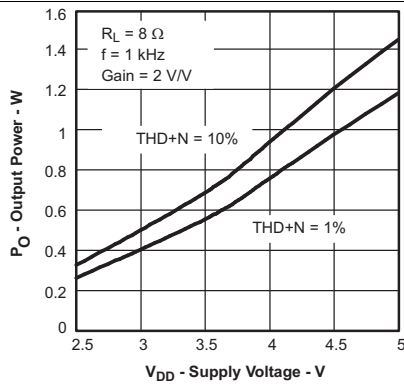

Figure 9. Output Power vs Supply Voltage

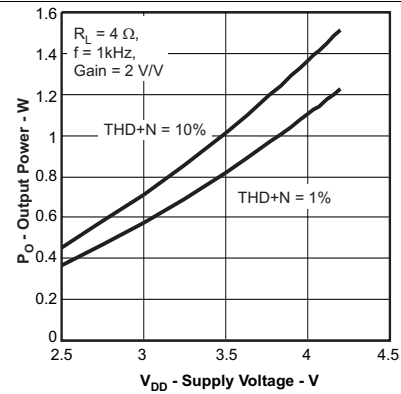

Figure 10. Output Power vs Supply Voltage

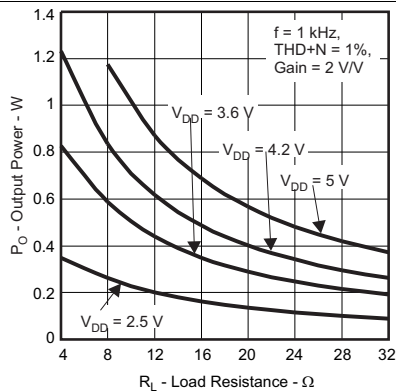

Figure 11. Output Power vs Load Resistance

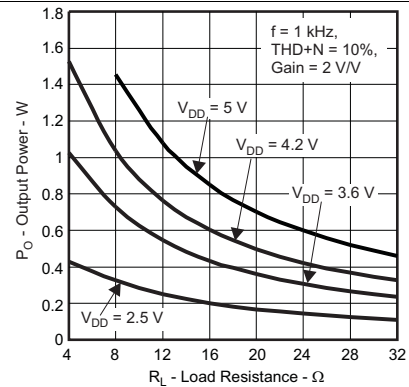

Figure 12. Output Power vs Load Resistance

Typical Characteristics (continued)

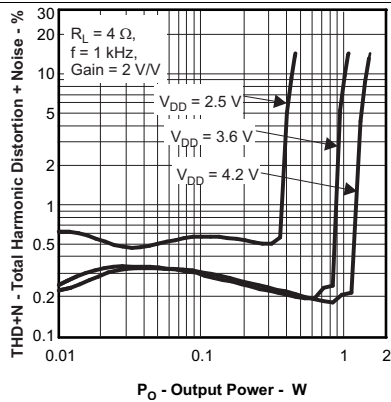

Figure 13. Total Harmonic Distortion + Noise vs Output Power

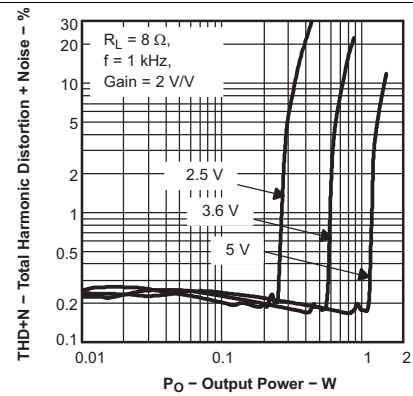

Figure 14. Total Harmonic Distortion + Noise vs Output Power

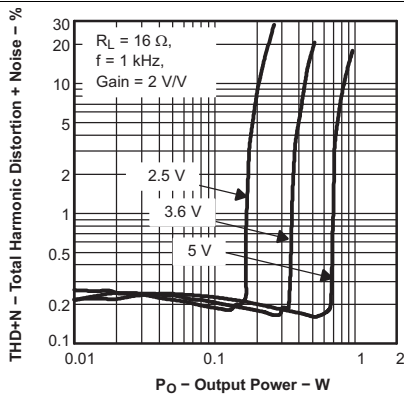

Figure 15. Total Harmonic Distortion + Noise vs Output Power

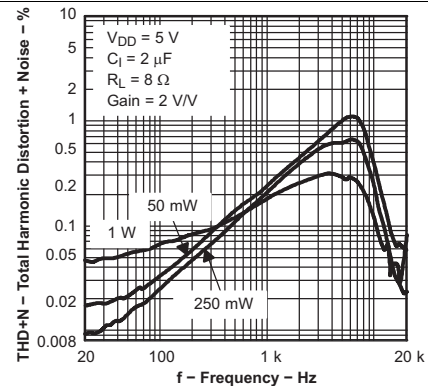

Figure 16. Total Harmonic Distortion + Noise vs Frequency

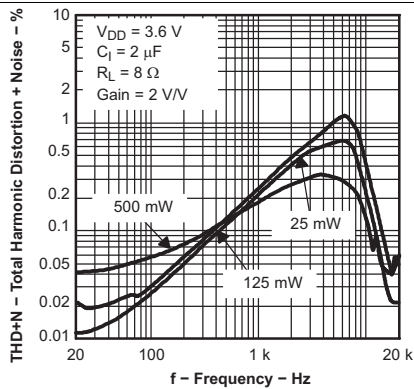

Figure 17. Total Harmonic Distortion + Noise vs Frequency

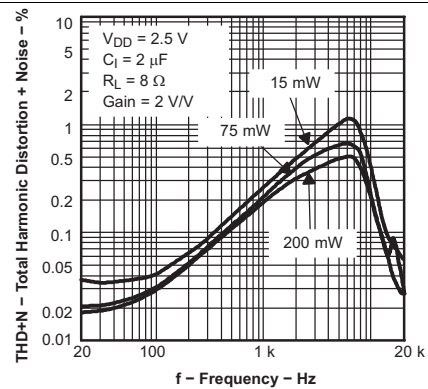

Figure 18. Total Harmonic Distortion + Noise vs Frequency

Typical Characteristics (continued)

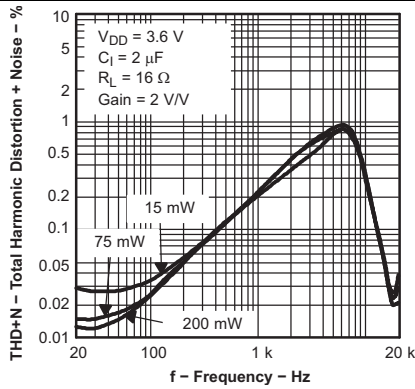

Figure 19. Total Harmonic Distortion + Noise vs Frequency

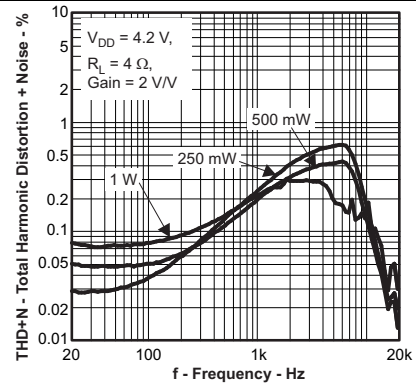

Figure 20. Total Harmonic Distortion + Noise vs Frequency

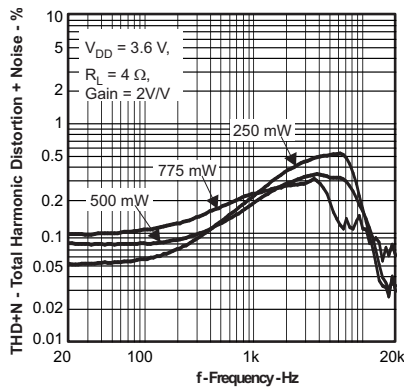

Figure 21. Total Harmonic Distortion + Noise vs Frequency

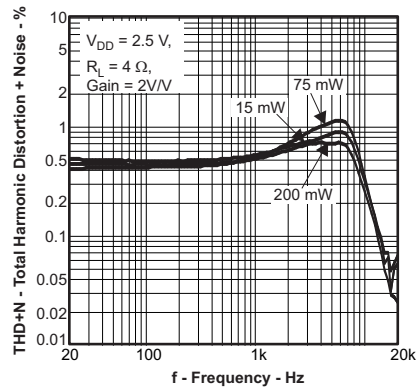

Figure 22. Total Harmonic Distortion + Noise vs Frequency

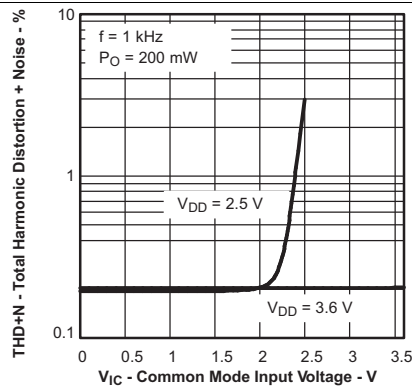

Figure 23. Total Harmonic Distortion + Noise vs Common Mode Input Voltage

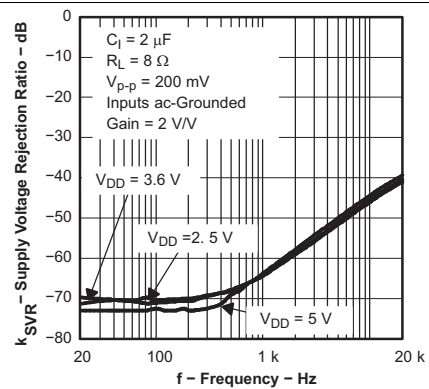

Figure 24. Supply Voltage Rejection Ratio vs Frequency

Typical Characteristics (continued)

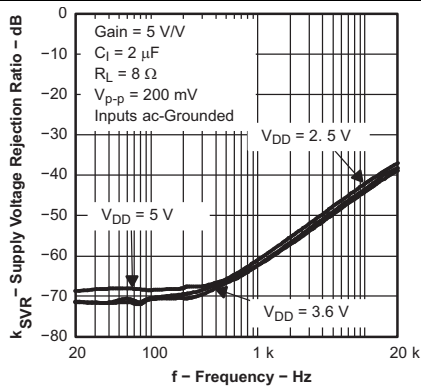

Figure 25. Supply Voltage Rejection Ratio vs Frequency 25

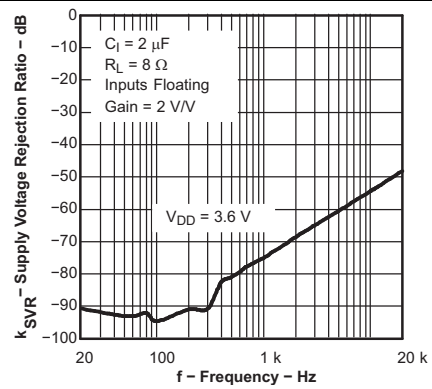

Figure 26. Supply Voltage Rejection Ratio vs Frequency

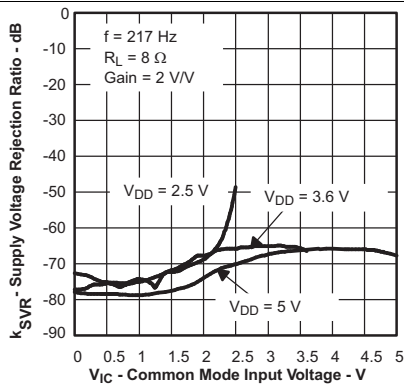

Figure 27. Supply Voltage Rejection Ratio vs Common-mode Input Voltage

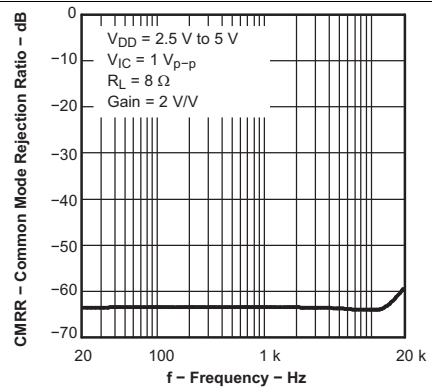

Figure 28. Common-mode Rejection Ratio vs Frequency

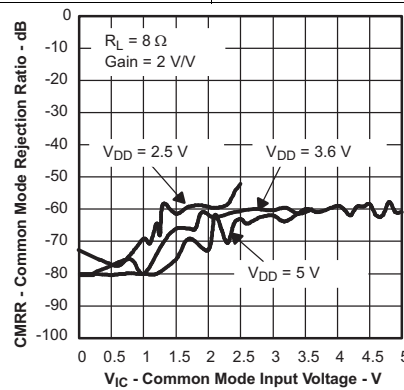
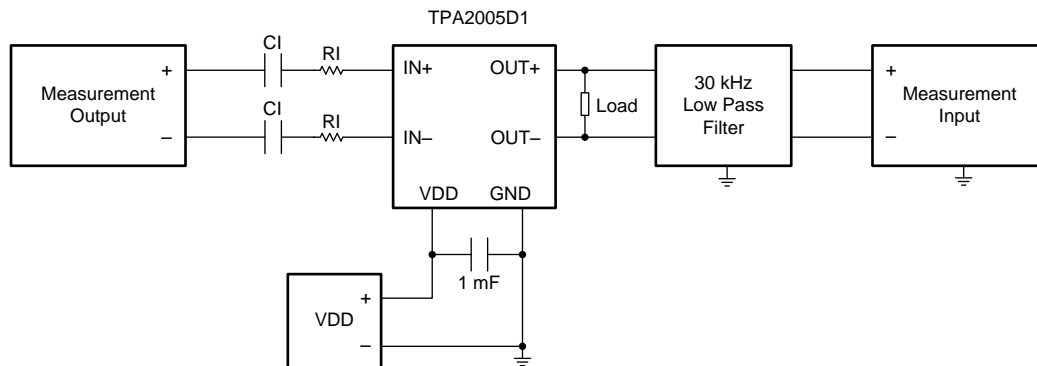

Figure 29. Common-mode Rejection Ratio vs Common-mode Input Voltage

8 Parameter Measurement Information



- A. C_1 was shorted for any common-mode input voltage measurement.
- B. A 33- μ H inductor was placed in series with the load resistor to emulate a small speaker for efficiency measurements.
- C. The 30-kHz low-pass filter is required, even if the analyzer has a low-pass filter. An RC filter (100 Ω , 47 nF) is used on each output for the data sheet graphs.

Figure 30. Test Setup For Graphs

9 Detailed Description

9.1 Overview

The TPA2005D1-Q1 is a high-efficiency filter-free Class-D audio amplifier capable of delivering up to 1.4 W into 8-Ω loads with a 5-V power supply. The fully-differential design of this amplifier avoids the usage of bypass capacitors and the improved CMRR eliminates the usage of input-coupling capacitors. This makes the device size a perfect choice for small, space constrained applications as only three external components are required. The advanced modulation used in the TPA2005D1-Q1 PWM output stage eliminates the need for an output filter.

9.2 Functional Block Diagram

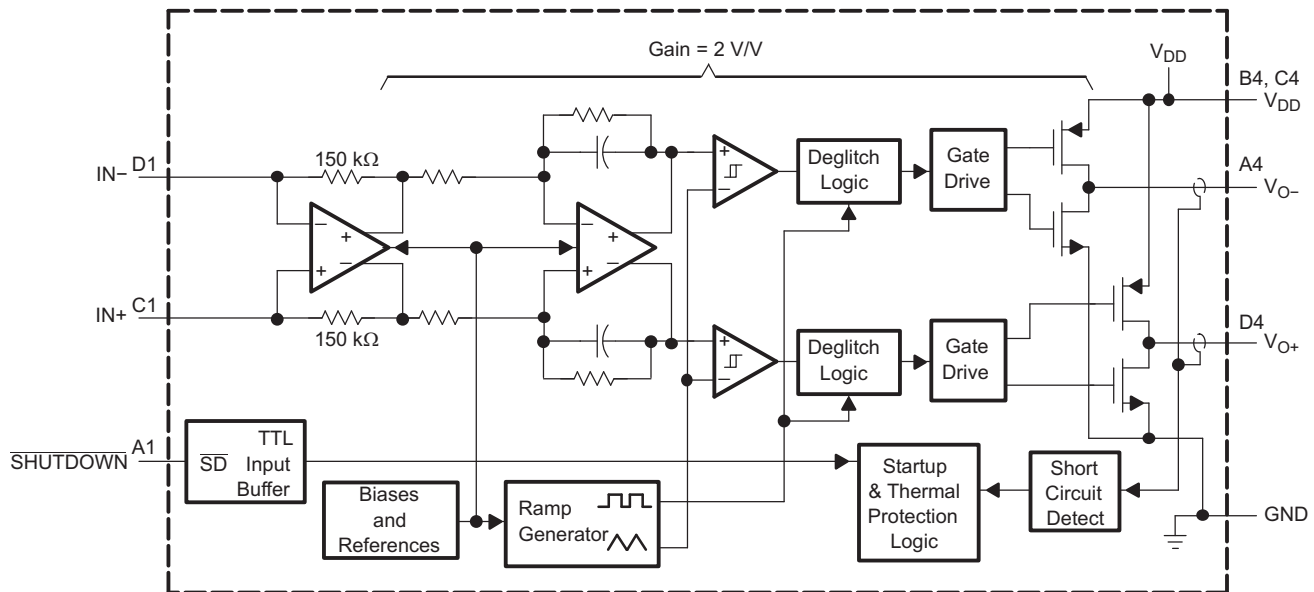

9.3 Feature Description

9.3.1 Fully Differential Amplifier

The TPA2005D1-Q1 is a fully differential amplifier with differential inputs and outputs. The fully differential amplifier consists of a differential amplifier and a common-mode amplifier. The differential amplifier ensures that the amplifier outputs a differential voltage on the output that is equal to the differential input times the gain. The common-mode feedback ensures that the common-mode voltage at the output is biased around $V_{DD}/2$, regardless of the common-mode voltage at the input. The fully differential TPA2005D1-Q1 can still be used with a single-ended input; however, the TPA2005D1-Q1 should be used with differential inputs when in a noisy environment to ensure maximum noise rejection.

9.3.1.1 Advantages Of Fully Differential Amplifiers

- Input-coupling capacitors not required:
 - The fully differential amplifier allows the inputs to be biased at a voltage other than mid-supply. For example, if a codec has a mid-supply lower than the mid-supply of the TPA2005D1-Q1, the common-mode feedback circuit adjusts, and the TPA2005D1-Q1 outputs still is biased at mid-supply of the TPA2005D1-Q1. The inputs of the TPA2005D1-Q1 can be biased from 0.5 V to $V_{DD} - 0.8$ V. If the inputs are biased outside of that range, input-coupling capacitors are required.
- Mid-supply bypass capacitor, $C_{(BYPASS)}$, not required:
 - The fully differential amplifier does not require a bypass capacitor. This is because any shift in the mid-supply affects both positive and negative channels equally and cancels at the differential output.
- Better RF immunity:
 - The fully differential amplifier cancels noise from RF interference much better than the typical audio amplifier.

Feature Description (continued)

9.3.2 Efficiency and Thermal Information

As an example, the DRB package has a θ_{JA} of 49.5°C/W, the maximum allowable junction temperature of 150°C, and the maximum internal dissipation of 0.2 W (worst case 5-V supply), the maximum ambient temperature can be calculated with Equation 1.

$$T_{A\text{Max}} = T_{J\text{Max}} - \theta_{JA} P_{D\text{max}} = 150 - 62.5 (0.2) = 137.5^\circ\text{C} \quad (1)$$

Equation 1 shows that the calculated maximum ambient temperature is 140.1°C at maximum power dissipation with a 5-V supply; however, the maximum ambient temperature of the package is limited to 85°C (note that the TPA2005D1TDGNRQ1 supports up to 105°C). Because of the efficiency of the TPA2005D1-Q1, it can be operated under all conditions to an ambient temperature of 85°C. The TPA2005D1-Q1 is designed with thermal protection that turns the device off when the junction temperature surpasses 150°C to prevent damage to the IC. Also, using speakers more resistive than 8 Ω dramatically increases the thermal performance by reducing the output current and increasing the efficiency of the amplifier.

9.3.3 Eliminating the Output Filter With the TPA2005D1-Q1

This section focuses on why the user can eliminate the output filter with the TPA2005D1-Q1.

9.3.3.1 Effect On Audio

The class-D amplifier outputs a pulse-width modulated (PWM) square wave, which is the sum of the switching waveform and the amplified input audio signal. The human ear acts as a band-pass filter such that only the frequencies between approximately 20 Hz and 20 kHz are passed. The switching frequency components are much greater than 20 kHz, so the only signal heard is the amplified input audio signal.

9.3.3.2 Traditional Class-D Modulation Scheme

The traditional class-D modulation scheme has a differential output in which each output is 180 degrees out of phase and changes from ground to the supply voltage, V_{DD} . Therefore, the differential pre-filtered output varies between positive and negative V_{DD} , where filtered 50% duty cycle yields 0 V across the load. The traditional class-D modulation scheme with voltage and current waveforms is shown in Figure 31. Note that, even at an average of 0 V across the load (50% duty cycle), the current to the load is high, causing a high loss and thus causing a high supply current.

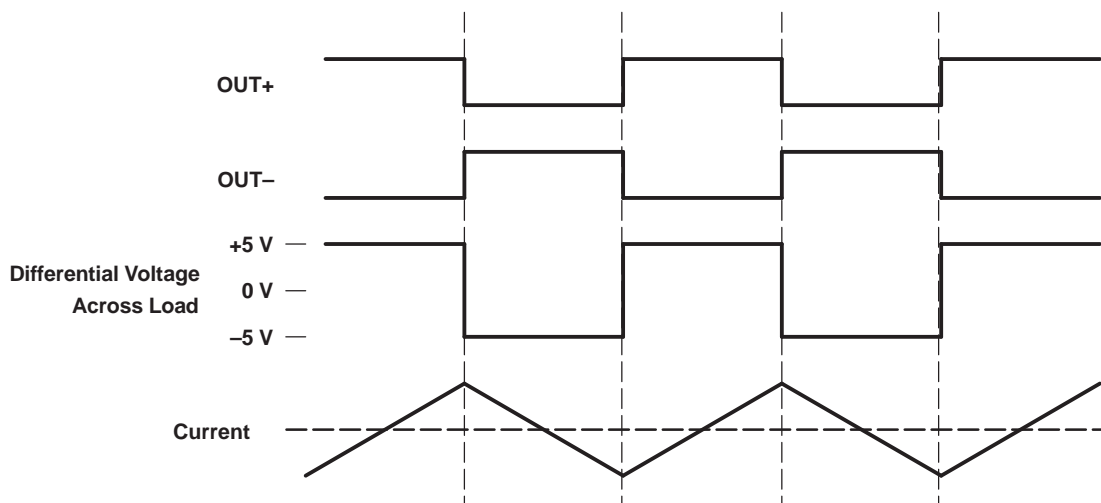

Figure 31. Traditional Class-D Modulation Scheme Output Voltage and Current Waveforms Into an Inductive Load With No Input

Feature Description (continued)

9.3.3.3 TPA2005D1-Q1 Modulation Scheme

The TPA2005D1-Q1 uses a modulation scheme that still has each output switching from 0 to the supply voltage. However, OUT+ and OUT– are now in phase with each other, with no input. The duty cycle of OUT+ is greater than 50% and OUT– is less than 50% for positive voltages. The duty cycle of OUT+ is less than 50% and OUT– is greater than 50% for negative voltages. The voltage across the load remains at 0 V throughout most of the switching period, greatly reducing the switching current, which reduces any I^2R losses in the load.

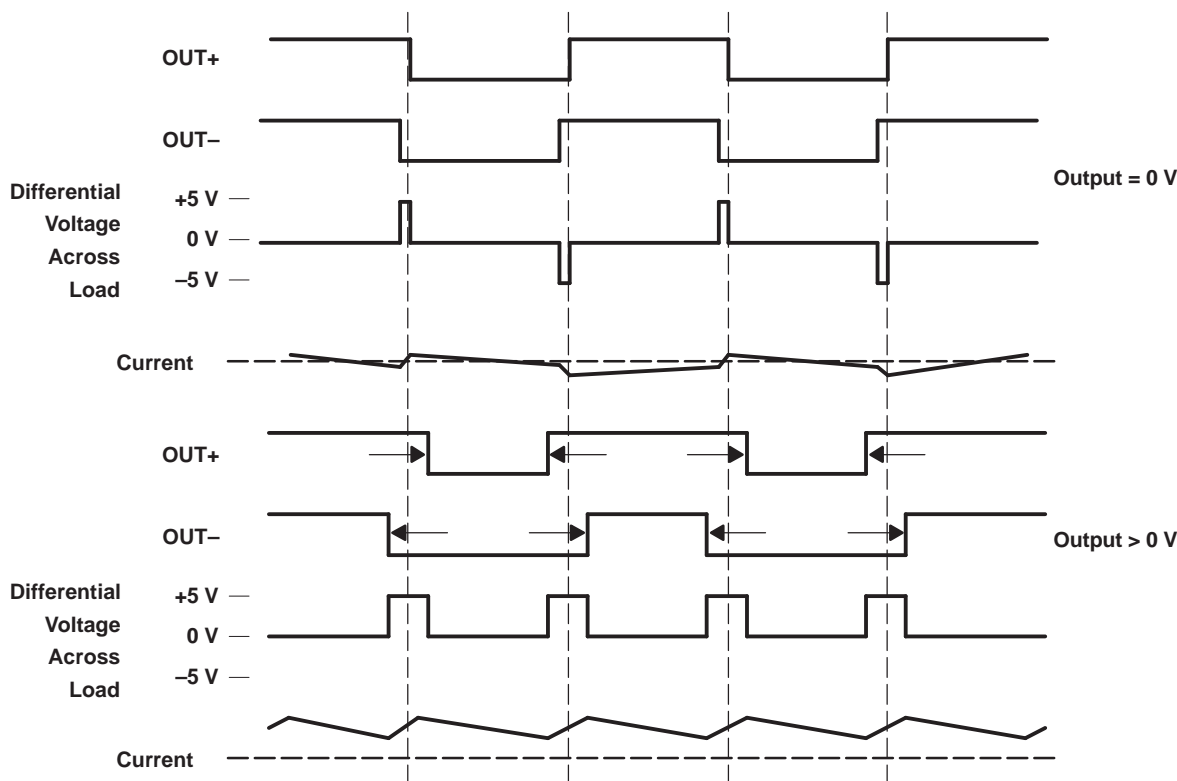

Figure 32. TPA2005D1-Q1 Output Voltage and Current Waveforms Into an Inductive Load

9.3.3.4 Efficiency: Why You Must Use a Filter With The Traditional Class-D Modulation Scheme

The main reason that the traditional class-D amplifier needs an output filter is that the switching waveform results in maximum current flow. This causes more loss in the load, which causes lower efficiency. The ripple current is large for the traditional modulation scheme because the ripple current is proportional to voltage multiplied by the time at that voltage. The differential voltage swing is $2 \times V_{DD}$, and the time at each voltage is one-half the period for the traditional modulation scheme. An ideal LC filter is needed to store the ripple current from each half-cycle for the next half-cycle, while any resistance causes power dissipation. The speaker is both resistive and reactive, whereas an LC filter is almost purely reactive.

The TPA2005D1-Q1 modulation scheme has very little loss in the load without a filter because the pulses are very short and the change in voltage is V_{DD} instead of $2 \times V_{DD}$. As the output power increases, the pulses widen, making the ripple current larger. Ripple current could be filtered with an LC filter for increased efficiency, but for most applications the filter is not needed.

An LC filter with a cutoff frequency less than the class-D switching frequency allows the switching current to flow through the filter instead of the load. The filter has less resistance than the speaker, resulting in less power dissipation, which increases efficiency.

Feature Description (continued)

9.3.3.5 Effects Of Applying a Square Wave Into a Speaker

If the amplitude of a square wave is high enough and the frequency of the square wave is within the bandwidth of the speaker, a square wave could cause the voice coil to jump out of the air gap and/or scar the voice coil. A 250-kHz switching frequency, however, is not significant because the speaker cone movement is proportional to $1/f^2$ for frequencies beyond the audio band. Therefore, the amount of cone movement at the switching frequency is very small. However, damage could occur to the speaker if the voice coil is not designed to handle the additional power. To size the speaker for added power, the ripple current dissipated in the load must be calculated by subtracting the theoretical supplied power, $P_{SUP\ THEORETICAL}$, from the actual supply power, P_{SUP} , at maximum output power, P_{OUT} . The switching power dissipated in the speaker is the inverse of the measured efficiency, $\eta_{MEASURED}$, minus the theoretical efficiency, $\eta_{THEORETICAL}$.

$$P_{SPKR} = P_{SUP} - P_{SUP\ THEORETICAL} \quad (\text{at max output power}) \quad (2)$$

$$P_{SPKR} = \frac{P_{SUP}}{P_{OUT}} - \frac{P_{SUP\ THEORETICAL}}{P_{OUT}} \quad (\text{at max output power}) \quad (3)$$

$$P_{SPKR} = P_{OUT} \left(\frac{1}{\eta_{MEASURED}} - \frac{1}{\eta_{THEORETICAL}} \right) \quad (\text{at max output power}) \quad (4)$$

$$\eta_{THEORETICAL} = \frac{R_L}{R_L + 2r_{DS(on)}} \quad (\text{at max output power}) \quad (5)$$

The maximum efficiency of the TPA2005D1-Q1 with a 3.6-V supply and an 8-Ω load is 86% from [Equation 5](#). Using [Equation 4](#) with the efficiency at maximum power (84%), we see that there is an additional 17 mW dissipated in the speaker. The added power dissipated in the speaker is not an issue as long as it is taken into account when choosing the speaker.

9.3.3.6 When to Use an Output Filter

Design the TPA2005D1-Q1 without an output filter if the traces from amplifier to speaker are short. The TPA2005D1-Q1 passed FCC and CE radiated emissions with no shielding and with speaker trace wires 100 mm long or less.

A ferrite bead filter often can be used if the design is failing radiated emissions without an LC filter, and the frequency-sensitive circuit is greater than 1 MHz. If choosing a ferrite bead, choose one with high impedance at high frequencies, but very low impedance at low frequencies.

Use an LC output filter if there are low-frequency (<1 MHz) EMI-sensitive circuits and/or there are long leads from amplifier to speaker.

[Figure 33](#) and [Figure 34](#) show typical ferrite bead and LC output filters.

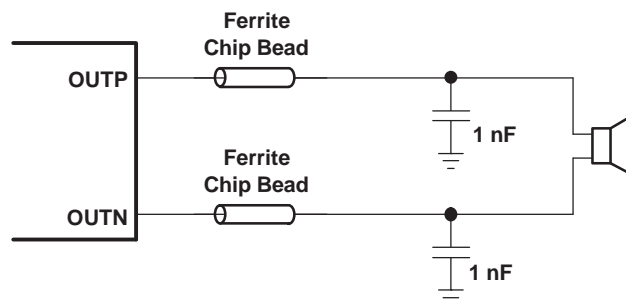

Figure 33. Typical Ferrite Chip Bead Filter (Chip Bead Example: NEC/Tokin: N2012ZPS121)

Feature Description (continued)

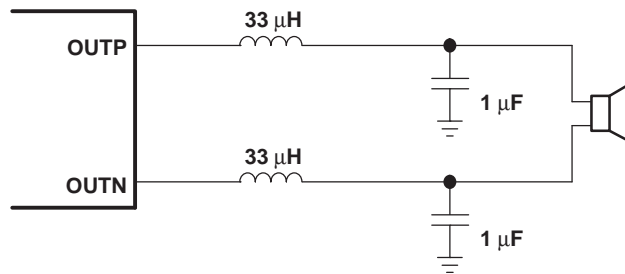

Figure 34. Typical LC Output Filter, Cutoff Frequency off 27 kHz

9.4 Device Functional Modes

9.4.1 Summing Input Signals With the TPA2005D1-Q1

The TPA2005D1-Q1 makes it easy to sum signal sources or use separate signal sources with different gains. This allows one speaker to be connected to the TPA2005D1-Q1 with multiple input sources. It can also be used to output a stereo signal to a mono speaker by summing the left and right channels.

9.4.1.1 Summing Two Differential Input Signals

Two extra resistors are needed for summing differential signals (a total of 5 components). The gain for each input source can be set independently (see [Equation 6](#) and [Equation 7](#) and [Figure 35](#)).

$$\text{Gain 1} = \frac{V_O}{V_{I1}} = 2 \times \frac{150 \text{ k}\Omega}{R_{I1}} \left(\frac{\text{V}}{\text{V}} \right) \quad (6)$$

$$\text{Gain 2} = \frac{V_O}{V_{I2}} = 2 \times \frac{150 \text{ k}\Omega}{R_{I2}} \left(\frac{\text{V}}{\text{V}} \right) \quad (7)$$

If summing left and right inputs with a gain of 1 V/V, use $R_{I1} = R_{I2} = 300 \text{ k}\Omega$.

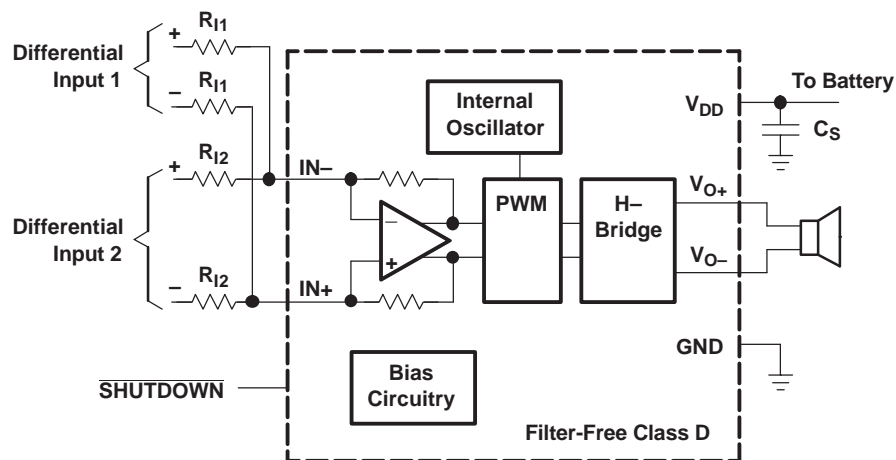

Figure 35. Application Schematic With TPA2005D1-Q1 Summing Two Differential Inputs

9.4.1.2 Summing A Differential Input Signal And A Single-Ended Input Signal

[Figure 36](#) shows how to sum a differential input signal and a single-ended input signal. Ground noise can couple in through IN+ with this method. It is better to use differential inputs. The corner frequency of the single-ended input is set by C_{I2} , shown in [Equation 10](#). To ensure that each input is balanced, the single-ended input must be driven by a low-impedance source even if the input is not in use.

Device Functional Modes (continued)

$$\text{Gain 1} = \frac{V_O}{V_{I1}} = 2 \times \frac{150 \text{ k}\Omega}{R_{I1}} \left(\frac{V}{V} \right) \tag{8}$$

$$\text{Gain 2} = \frac{V_O}{V_{I2}} = 2 \times \frac{150 \text{ k}\Omega}{R_{I2}} \left(\frac{V}{V} \right) \tag{9}$$

$$C_{I2} = \frac{1}{(2\pi R_{I2} f_{c2})} \tag{10}$$

The high-pass corner frequency of the single-ended input is set by C_{I2} . If the desired corner frequency is less than 20 Hz, then:

$$C_{I2} > \frac{1}{(2\pi 150\text{k}\Omega 20\text{Hz})} \tag{11}$$

$$C_{I2} > 53\text{pF} \tag{12}$$

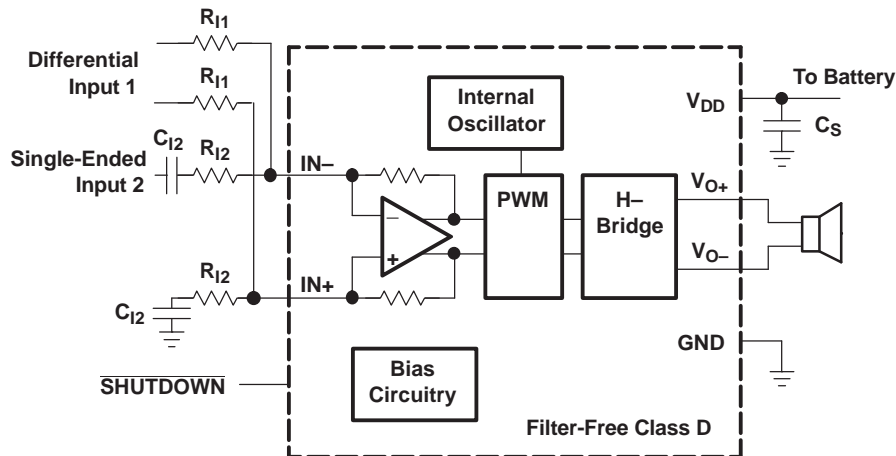

Figure 36. Application Schematic With TPA2005D1-Q1 Summing Differential Input And Single-Ended Input Signals

9.4.1.3 Summing Two Single-Ended Input Signals

Four resistors and three capacitors are needed for summing single-ended input signals. The gain and corner frequencies (f_{c1} and f_{c2}) for each input source can be set independently (see Equation 13 through Equation 16 and Figure 37). Resistor, R_P , and capacitor, C_P , are needed on the $IN+$ terminal to match the impedance on the $IN-$ terminal. The single-ended inputs must be driven by low-impedance sources, even if one of the inputs is not outputting an AC signal.

$$\text{Gain 1} = \frac{V_O}{V_{I1}} = 2 \times \frac{150 \text{ k}\Omega}{R_{I1}} \left(\frac{V}{V} \right) \tag{13}$$

$$\text{Gain 2} = \frac{V_O}{V_{I2}} = 2 \times \frac{150 \text{ k}\Omega}{R_{I2}} \left(\frac{V}{V} \right) \tag{14}$$

$$C_{I1} = \frac{1}{(2\pi R_{I1} f_{c1})} \tag{15}$$

$$C_{I2} = \frac{1}{(2\pi R_{I2} f_{c2})} \tag{16}$$

$$C_P = C_{I1} + C_{I2} \tag{17}$$

Device Functional Modes (continued)

$$R_P = \frac{R_{I1} \times R_{I2}}{(R_{I1} + R_{I2})}$$

(18)

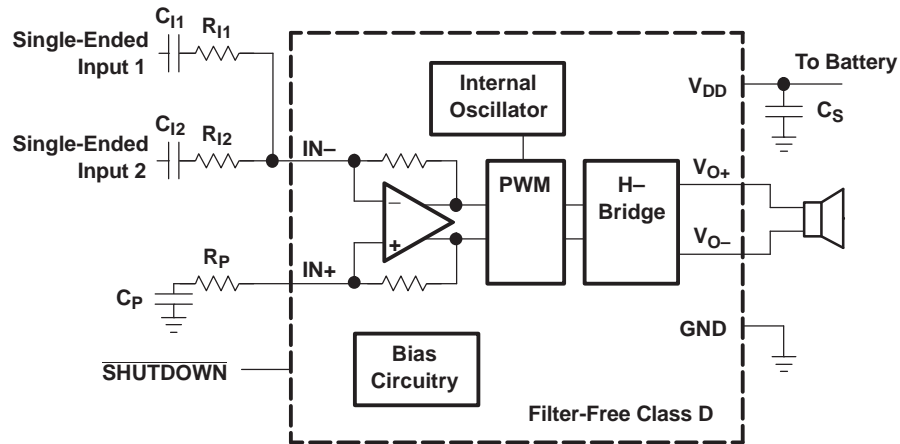

Figure 37. Application Schematic With TPA2005D1-Q1 Summing Two Single-Ended Inputs

10 Application and Implementation

NOTE

Information in the following applications sections is not part of the TI component specification, and TI does not warrant its accuracy or completeness. TI's customers are responsible for determining suitability of components for their purposes. Customers should validate and test their design implementation to confirm system functionality.

10.1 Application Information

These typical connection diagrams highlight the required external components and system level connections for proper operation of the device in several popular use cases.

Each of these configurations can be realized using the Evaluation Modules (EVMS) for the device. These flexible modules allow full evaluation of the device in the most common modes of operation. Any design variation can be supported by TI through schematic and layout reviews. Visit <http://e2e.ti.com> for design assistance.

10.2 Typical Application

10.2.1 TPA2005D1-Q1 with Differential Input

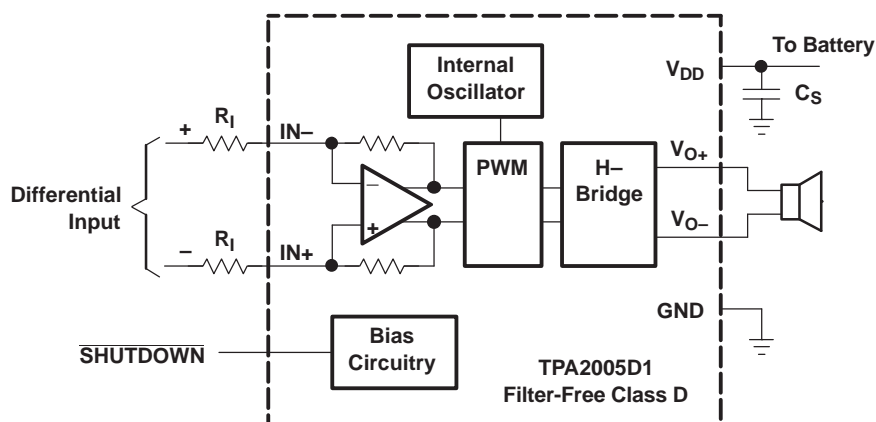

Figure 38. Typical TPA2005D1-Q1 Application Schematic With Differential Input

10.2.1.1 Design Requirements

For this design example, use the parameters listed in [Table 1](#)

Table 1. Design Requirements

PARAMETER	EXAMPLE
Power Supply	5 V
Shutdown Input	High > 2 V
	Low < 0.8 V
Speaker	8 Ω

10.2.1.2 Detailed Design Procedure

10.2.1.2.1 Component Selection

Figure 38 shows the TPA2005D1-Q1 typical schematic with differential inputs, and Figure 40 shows the TPA2005D1-Q1 with differential inputs and input capacitors, and Figure 41 shows the TPA2005D1-Q1 with single-ended inputs. Differential inputs should be used whenever possible, because the single-ended inputs are much more susceptible to noise.

Table 2. Typical Component Values

REF DES	VALUE	EIA SIZE	MANUFACTURER	PART NUMBER
R _I	150 kΩ (±0.5%)	0402	Panasonic	ERJ2RHD154V
C _S	1 μF (+22%, –80%)	0402	Murata	GRP155F50J105Z
C _I ⁽¹⁾	3.3 nF (±10%)	0201	Murata	GRP033B10J332K

(1) C_I is needed only for single-ended input or if V_{ICM} is not between 0.5 V and V_{DD} – 0.8 V. C_I = 3.3 nF (with R_I = 150 kΩ) gives a high-pass corner frequency of 321 Hz.

10.2.1.2.2 Input Resistors (R_I)

The input resistors (R_I) set the gain of the amplifier according to equation Equation 19.

$$\text{Gain} = 2 \times \frac{150 \text{ k}\Omega}{R_I} \quad (19)$$

Resistor matching is very important in fully differential amplifiers. The balance of the output on the reference voltage depends on matched ratios of the resistors. CMRR, PSRR, and cancellation of the second harmonic distortion diminish if resistor mismatch occurs. Therefore, it is recommended to use 1% tolerance resistors, or better, to keep the performance optimized. Matching is more important than overall tolerance. Resistor arrays with 1% matching can be used with a tolerance greater than 1%.

Place the input resistors very close to the TPA2005D1-Q1 to limit noise injection on the high-impedance nodes.

For optimal performance, the gain should be set to 2 V/V or lower. Lower gain allows the TPA2005D1-Q1 to operate at its best and keeps a high voltage at the input, making the inputs less susceptible to noise.

10.2.1.2.3 Decoupling Capacitor (C_S)

The TPA2005D1-Q1 is a high-performance class-D audio amplifier that requires adequate power-supply decoupling to ensure the efficiency is high and total harmonic distortion (THD) is low. For higher frequency transients, spikes, or digital hash on the line, a good low equivalent-series-resistance (ESR) ceramic capacitor, typically 1 μF, placed as close as possible to the device V_{DD} lead, works best. Placing this decoupling capacitor close to the TPA2005D1-Q1 is very important for the efficiency of the class-D amplifier, because any resistance or inductance in the trace between the device and the capacitor can cause a loss in efficiency. For filtering lower-frequency noise signals, a 10-μF, or greater, capacitor placed near the audio power amplifier also helps, but it is not required in most applications because of the high PSRR of this device.

10.2.1.3 Application Curve

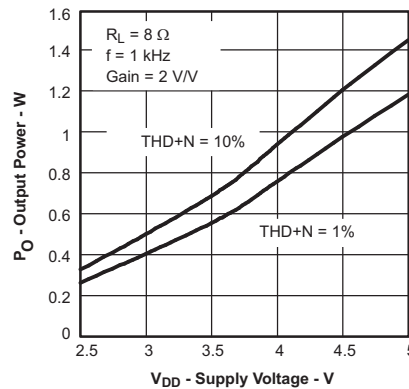

Figure 39. Output Power vs Supply Voltage

10.2.2 TPA2005D1-Q1 with Differential Input and Input Capacitors

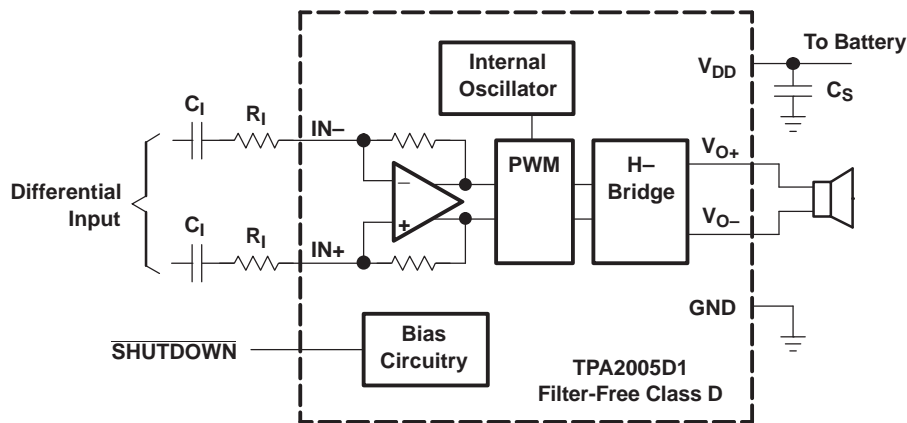

Figure 40. TPA2005D1-Q1 Application Schematic With Differential Input And Input Capacitors

10.2.2.1 Detailed Design Requirements

10.2.2.1.1 Input Capacitors (C_I)

The TPA2005D1-Q1 does not require input coupling capacitors if the design uses a differential source that is biased from 0.5 V to V_{DD} – 0.8 V (shown in Figure 38). If the input signal is not biased within the recommended common-mode input range, if needing to use the input as a high pass filter (shown in Figure 40), or if using a single-ended source (shown in Figure 41), input coupling capacitors are required.

The input capacitors and input resistors form a high-pass filter with the corner frequency, f_c, determined in Equation 20.

$$f_c = \frac{1}{(2\pi R_I C_I)} \quad (20)$$

The value of the input capacitor is important to consider, as it directly affects the bass (low frequency) performance of the circuit.

Equation 21 is reconfigured to solve for the input coupling capacitance.

$$C_I = \frac{1}{(2\pi R_I f_c)} \quad (21)$$

If the corner frequency is within the audio band, the capacitors should have a tolerance of ±10% or better, because any mismatch in capacitance causes an impedance mismatch at the corner frequency and below.

For a flat low-frequency response, use large input coupling capacitors (1 μF).

10.2.3 TPA2005D1-Q1 with Single-Ended Input

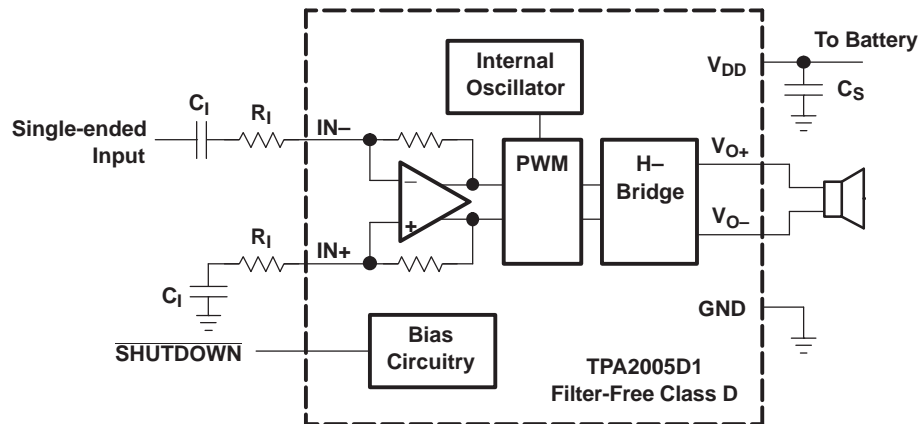

Figure 41. TPA2005D1-Q1 Application Schematic With Single-Ended Input

11 Power Supply Recommendations

The TPA2005D1-Q1 is designed to operate from an input voltage supply range between 2.5-V and 5.5-V. Therefore, the output voltage range of power supply should be within this range and well regulated. The current capability of upper power should not exceed the maximum current limit of the power switch.

11.1 Power Supply Decoupling Capacitors

The TPA2005D1-Q1 requires adequate power supply decoupling to ensure a high efficiency operation with low total harmonic distortion (THD). Place a low equivalent-series-resistance (ESR) ceramic capacitor, typically 0.1 μF , within 2 mm of the V_{DD} pin. This choice of capacitor and placement helps with higher frequency transients, spikes, or digital hash on the line. In addition to the 0.1 μF ceramic capacitor, it is recommended to place a 2.2 μF to 10 μF capacitor on the VDD supply trace. This larger capacitor acts as a charge reservoir, providing energy faster than the board supply, thus helping to prevent any droop in the supply voltage.

12 Layout

12.1 Layout Guidelines

12.1.1 Component Location

Place all the external components very close to the TPA2005D1-Q1. The input resistors need to be very close to the TPA2005D1-Q1 input pins so noise does not couple on the high-impedance nodes between the input resistors and the input amplifier of the TPA2005D1-Q1. Placing the decoupling capacitor, C_S , close to the TPA2005D1-Q1 is important for the efficiency of the class-D amplifier. Any resistance or inductance in the trace between the device and the capacitor can cause a loss in efficiency.

12.1.2 Trace Width

Make the high current traces going to pins VDD, GND, V_{O+} and V_{O-} of the TPA2005D1-Q1 have a minimum width of 0.7 mm. If these traces are too thin, the TPA2005D1-Q1 performance and output power will decrease. The input traces do not need to be wide, but do need to run side-by-side to enable common-mode noise cancellation.

12.1.3 8-Pin QFN (DRB) Layout

Use the following land pattern for board layout with the 8-pin QFN (DRB) package. Note that the solder paste should use a hatch pattern to fill solder paste at 50% to ensure that there is not too much solder paste under the package.

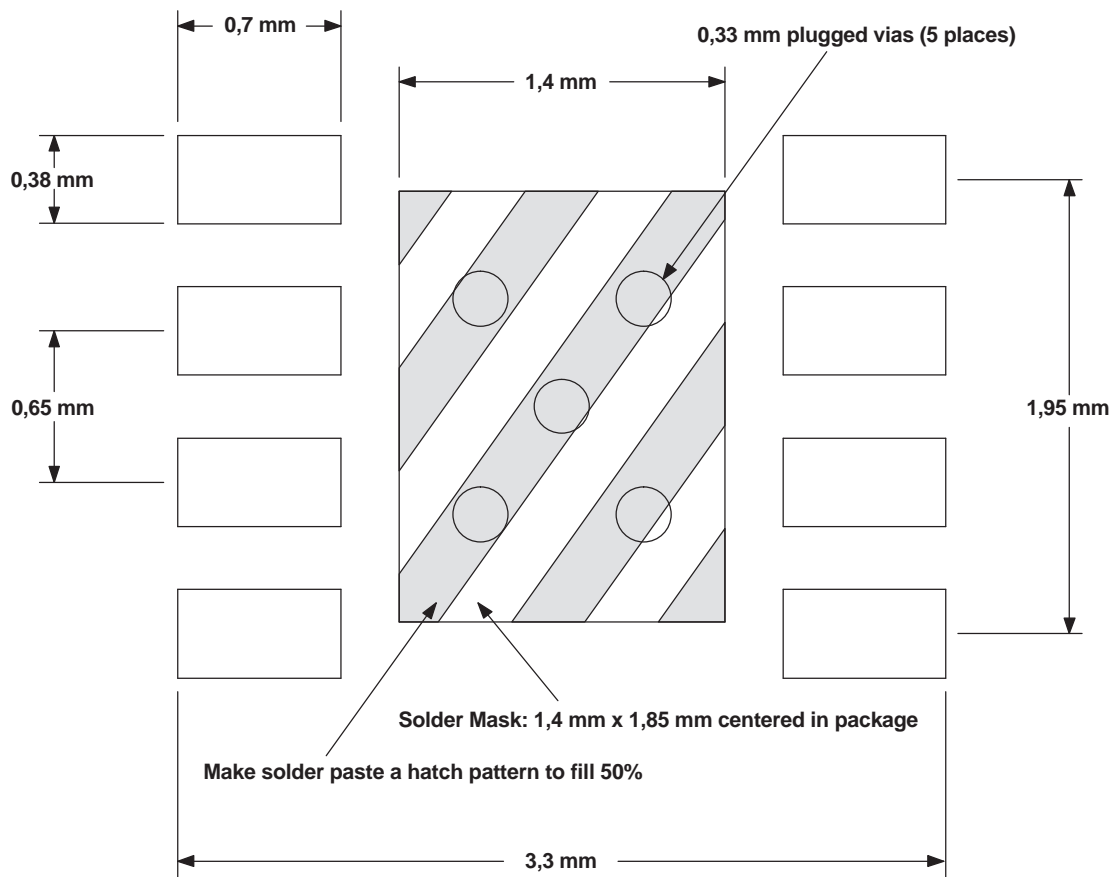

Figure 42. TPA2005D1-Q1 8-Pin QFN (DRB) Board Layout (Top View)

12.2 Layout Example

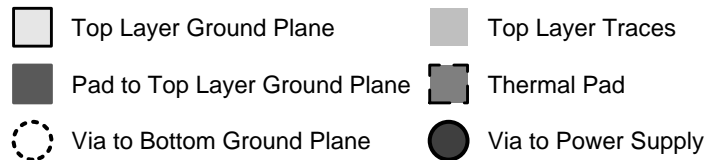
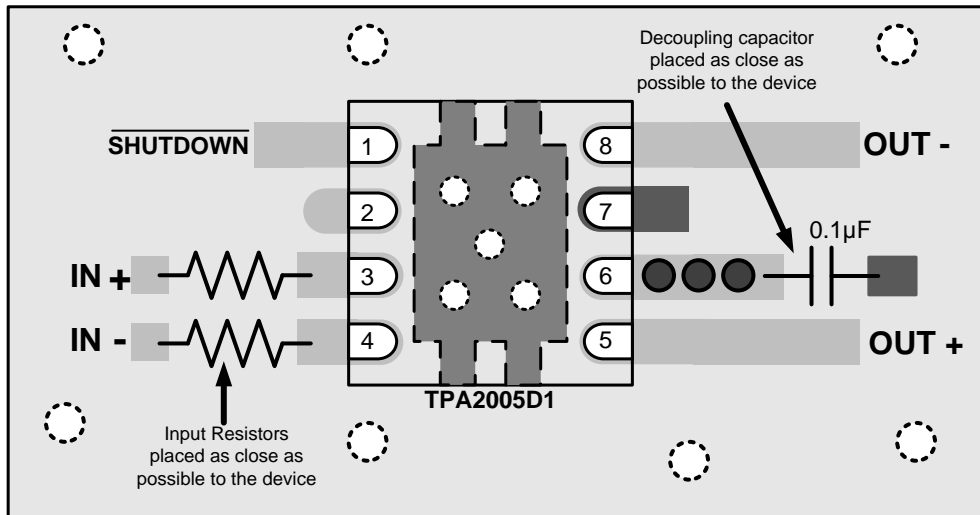

Figure 43. TPA2005D1-Q1 DRB Package Layout Example

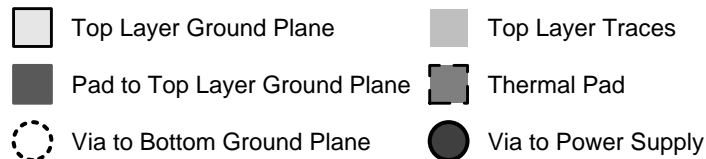
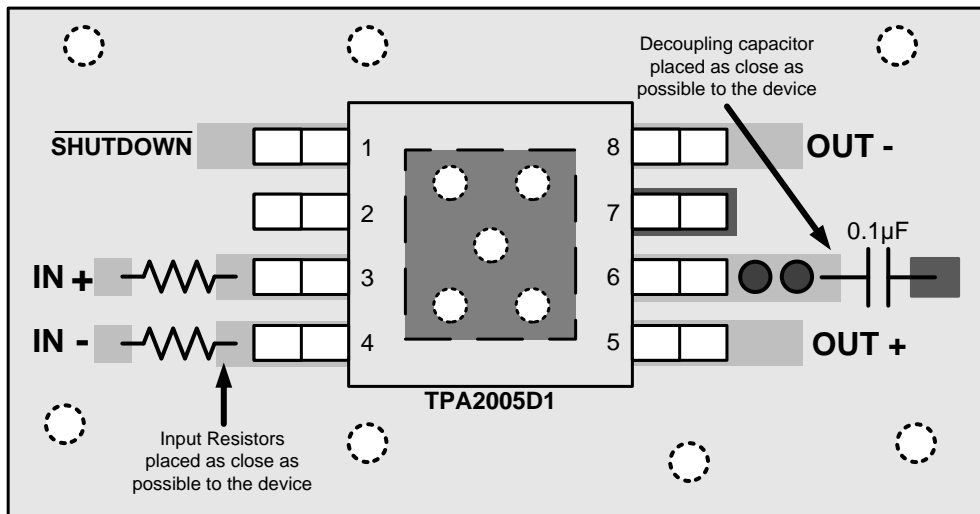

Figure 44. TPA2005D1-Q1 DGN Package Layout Example

13 Device and Documentation Support

13.1 Community Resource

The following links connect to TI community resources. Linked contents are provided "AS IS" by the respective contributors. They do not constitute TI specifications and do not necessarily reflect TI's views; see TI's [Terms of Use](#).

TI E2E™ Online Community *TI's Engineer-to-Engineer (E2E) Community*. Created to foster collaboration among engineers. At e2e.ti.com, you can ask questions, share knowledge, explore ideas and help solve problems with fellow engineers.

Design Support *TI's Design Support* Quickly find helpful E2E forums along with design support tools and contact information for technical support.

13.2 Trademarks

PowerPAD, E2E are trademarks of Texas Instruments.
All other trademarks are the property of their respective owners.

13.3 Electrostatic Discharge Caution



These devices have limited built-in ESD protection. The leads should be shorted together or the device placed in conductive foam during storage or handling to prevent electrostatic damage to the MOS gates.

13.4 Glossary

[SLYZ022](#) — *TI Glossary*.

This glossary lists and explains terms, acronyms, and definitions.

14 Mechanical, Packaging, and Orderable Information

The following pages include mechanical, packaging, and orderable information. This information is the most current data available for the designated devices. This data is subject to change without notice and revision of this document. For browser-based versions of this data sheet, refer to the left-hand navigation.

PACKAGING INFORMATION

Orderable Device	Status (1)	Package Type	Package Drawing	Pins	Package Qty	Eco Plan (2)	Lead/Ball Finish (6)	MSL Peak Temp (3)	Op Temp (°C)	Device Marking (4/5)	Samples
TPA2005D1DGNRQ1	ACTIVE	MSOP- PowerPAD	DGN	8	2500	Green (RoHS & no Sb/Br)	CU NIPDAU	Level-2-260C-1 YEAR	-40 to 85	2005I	Samples
TPA2005D1DRBQ1	ACTIVE	SON	DRB	8	3000	Green (RoHS & no Sb/Br)	CU NIPDAU	Level-2-260C-1 YEAR	-40 to 85	BIQ	Samples
TPA2005D1TDGNRQ1	ACTIVE	MSOP- PowerPAD	DGN	8	2500	Green (RoHS & no Sb/Br)	CU NIPDAU	Level-2-260C-1 YEAR	-40 to 105	2005T	Samples

(1) The marketing status values are defined as follows:

ACTIVE: Product device recommended for new designs.

LIFEBUY: TI has announced that the device will be discontinued, and a lifetime-buy period is in effect.

NRND: Not recommended for new designs. Device is in production to support existing customers, but TI does not recommend using this part in a new design.

PREVIEW: Device has been announced but is not in production. Samples may or may not be available.

OBSOLETE: TI has discontinued the production of the device.

(2) Eco Plan - The planned eco-friendly classification: Pb-Free (RoHS), Pb-Free (RoHS Exempt), or Green (RoHS & no Sb/Br) - please check <http://www.ti.com/productcontent> for the latest availability information and additional product content details.

TBD: The Pb-Free/Green conversion plan has not been defined.

Pb-Free (RoHS): TI's terms "Lead-Free" or "Pb-Free" mean semiconductor products that are compatible with the current RoHS requirements for all 6 substances, including the requirement that lead not exceed 0.1% by weight in homogeneous materials. Where designed to be soldered at high temperatures, TI Pb-Free products are suitable for use in specified lead-free processes.

Pb-Free (RoHS Exempt): This component has a RoHS exemption for either 1) lead-based flip-chip solder bumps used between the die and package, or 2) lead-based die adhesive used between the die and leadframe. The component is otherwise considered Pb-Free (RoHS compatible) as defined above.

Green (RoHS & no Sb/Br): TI defines "Green" to mean Pb-Free (RoHS compatible), and free of Bromine (Br) and Antimony (Sb) based flame retardants (Br or Sb do not exceed 0.1% by weight in homogeneous material)

(3) MSL, Peak Temp. - The Moisture Sensitivity Level rating according to the JEDEC industry standard classifications, and peak solder temperature.

(4) There may be additional marking, which relates to the logo, the lot trace code information, or the environmental category on the device.

(5) Multiple Device Markings will be inside parentheses. Only one Device Marking contained in parentheses and separated by a "~" will appear on a device. If a line is indented then it is a continuation of the previous line and the two combined represent the entire Device Marking for that device.

(6) Lead/Ball Finish - Orderable Devices may have multiple material finish options. Finish options are separated by a vertical ruled line. Lead/Ball Finish values may wrap to two lines if the finish value exceeds the maximum column width.

Important Information and Disclaimer: The information provided on this page represents TI's knowledge and belief as of the date that it is provided. TI bases its knowledge and belief on information provided by third parties, and makes no representation or warranty as to the accuracy of such information. Efforts are underway to better integrate information from third parties. TI has taken and

continues to take reasonable steps to provide representative and accurate information but may not have conducted destructive testing or chemical analysis on incoming materials and chemicals. TI and TI suppliers consider certain information to be proprietary, and thus CAS numbers and other limited information may not be available for release.

In no event shall TI's liability arising out of such information exceed the total purchase price of the TI part(s) at issue in this document sold by TI to Customer on an annual basis.

OTHER QUALIFIED VERSIONS OF TPA2005D1-Q1 :

- Catalog: [TPA2005D1](#)

NOTE: Qualified Version Definitions:

- Catalog - TI's standard catalog product

TAPE AND REEL INFORMATION

QUADRANT ASSIGNMENTS FOR PIN 1 ORIENTATION IN TAPE

*All dimensions are nominal

Device	Package Type	Package Drawing	Pins	SPQ	Reel Diameter (mm)	Reel Width W1 (mm)	A0 (mm)	B0 (mm)	K0 (mm)	P1 (mm)	W (mm)	Pin1 Quadrant
TPA2005D1DGNRQ1	MSOP-Power PAD	DGN	8	2500	330.0	12.4	5.3	3.4	1.4	8.0	12.0	Q1
TPA2005D1DRBQ1	SON	DRB	8	3000	330.0	12.4	3.3	3.3	1.1	8.0	12.0	Q2
TPA2005D1TDGNRQ1	MSOP-Power PAD	DGN	8	2500	330.0	12.4	5.3	3.4	1.4	8.0	12.0	Q1

TAPE AND REEL BOX DIMENSIONS

*All dimensions are nominal

Device	Package Type	Package Drawing	Pins	SPQ	Length (mm)	Width (mm)	Height (mm)
TPA2005D1DGNRQ1	MSOP-PowerPAD	DGN	8	2500	367.0	367.0	35.0
TPA2005D1DRBQ1	SON	DRB	8	3000	367.0	367.0	35.0
TPA2005D1TDGNRQ1	MSOP-PowerPAD	DGN	8	2500	367.0	367.0	35.0

DGN (S-PDSO-G8)

PowerPAD™ PLASTIC SMALL OUTLINE

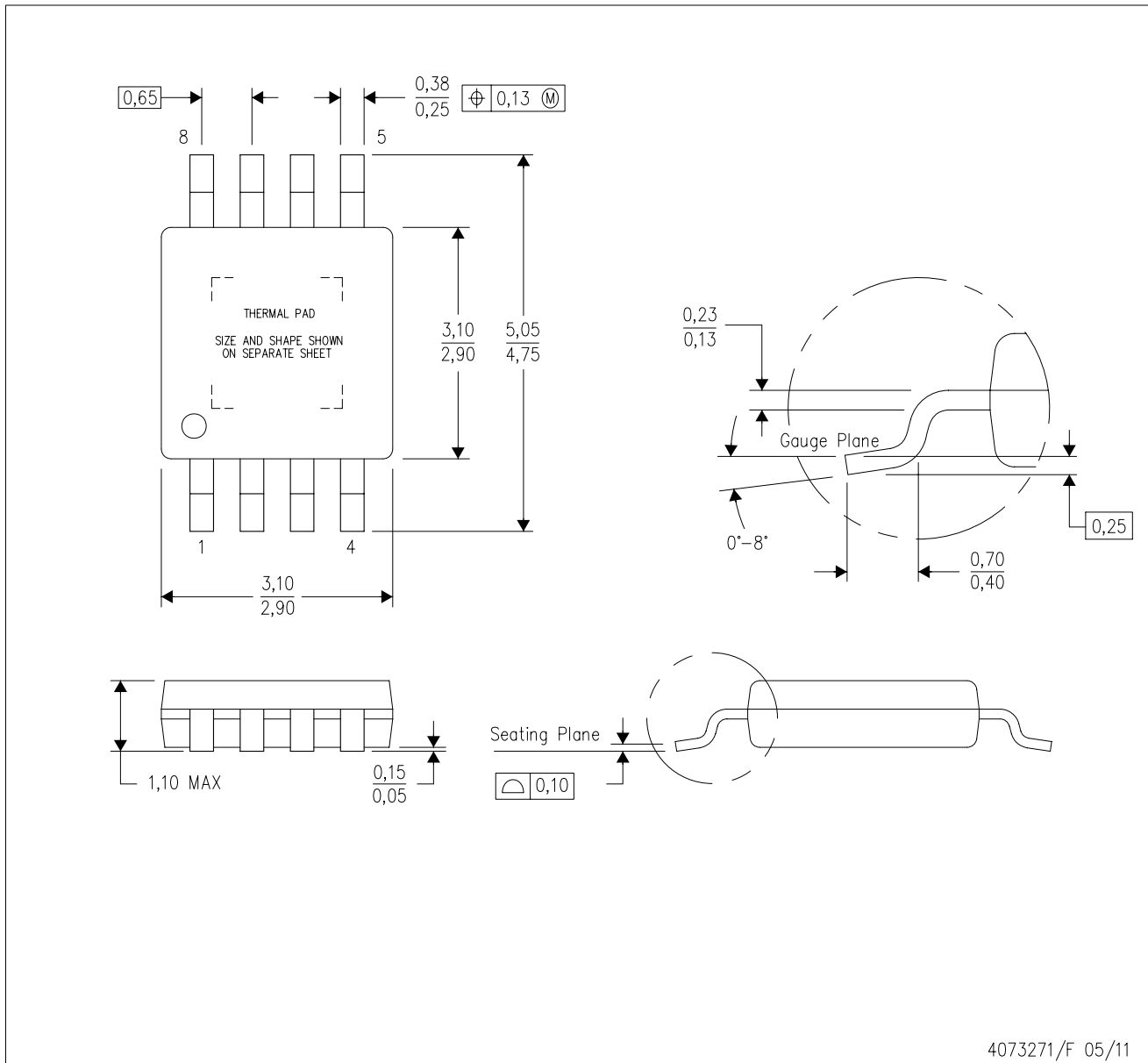

- NOTES:
- All linear dimensions are in millimeters.
 - This drawing is subject to change without notice.
 - Body dimensions do not include mold flash or protrusion.
 - This package is designed to be soldered to a thermal pad on the board. Refer to Technical Brief, PowerPad Thermally Enhanced Package, Texas Instruments Literature No. SLMA002 for information regarding recommended board layout. This document is available at www.ti.com <<http://www.ti.com>>.
 - See the additional figure in the Product Data Sheet for details regarding the exposed thermal pad features and dimensions.
 - Falls within JEDEC MO-187 variation AA-T

PowerPAD is a trademark of Texas Instruments.

DRB (S-PVSON-N8)

PLASTIC SMALL OUTLINE NO-LEAD

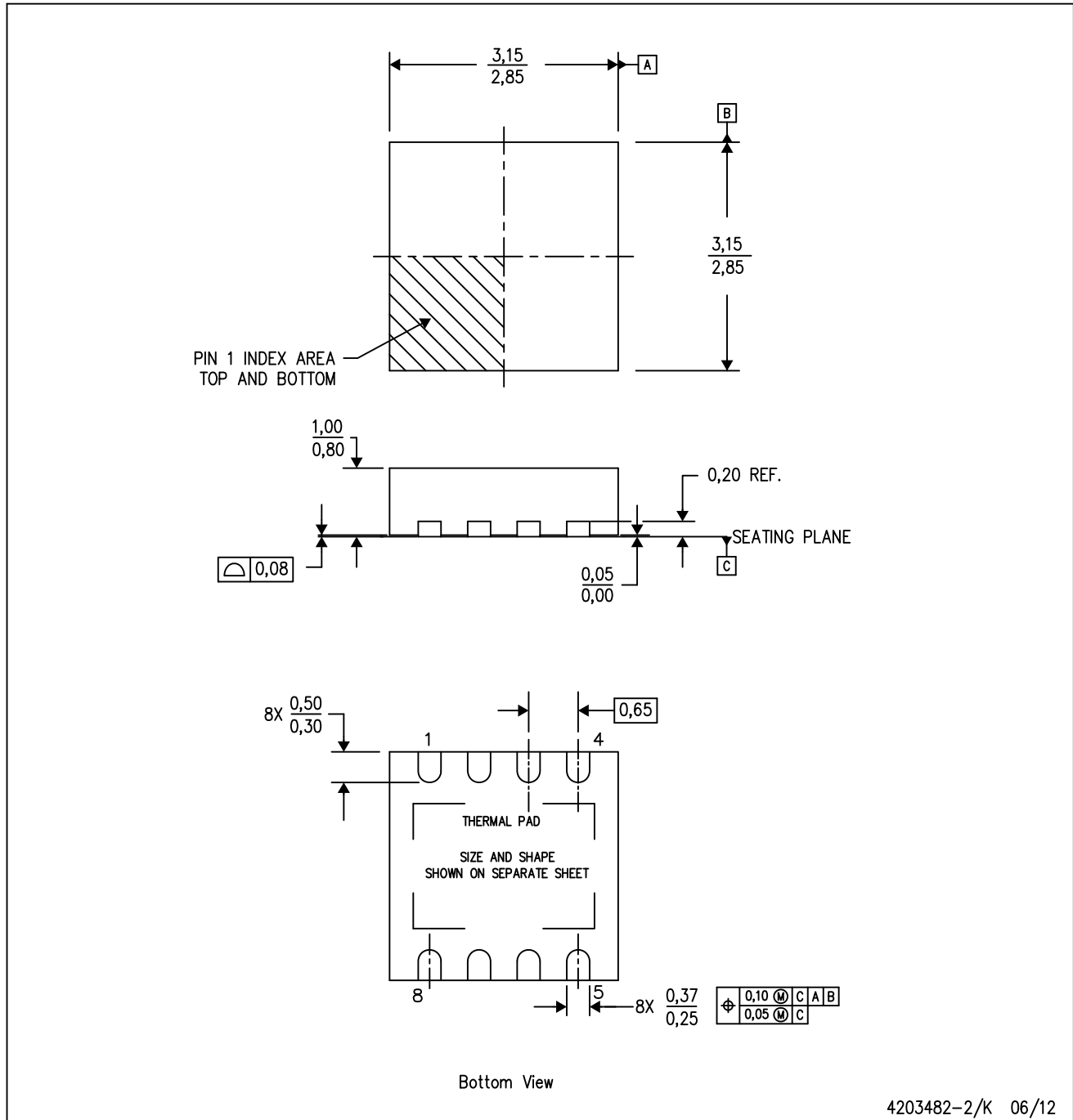

- NOTES:
- All linear dimensions are in millimeters. Dimensioning and tolerancing per ASME Y14.5M-1994.
 - This drawing is subject to change without notice.
 - Small Outline No-Lead (SON) package configuration.
 - The package thermal pad must be soldered to the board for thermal and mechanical performance.
 - See the additional figure in the Product Data Sheet for details regarding the exposed thermal pad features and dimensions.

IMPORTANT NOTICE

Texas Instruments Incorporated and its subsidiaries (TI) reserve the right to make corrections, enhancements, improvements and other changes to its semiconductor products and services per JESD46, latest issue, and to discontinue any product or service per JESD48, latest issue. Buyers should obtain the latest relevant information before placing orders and should verify that such information is current and complete. All semiconductor products (also referred to herein as "components") are sold subject to TI's terms and conditions of sale supplied at the time of order acknowledgment.

TI warrants performance of its components to the specifications applicable at the time of sale, in accordance with the warranty in TI's terms and conditions of sale of semiconductor products. Testing and other quality control techniques are used to the extent TI deems necessary to support this warranty. Except where mandated by applicable law, testing of all parameters of each component is not necessarily performed.

TI assumes no liability for applications assistance or the design of Buyers' products. Buyers are responsible for their products and applications using TI components. To minimize the risks associated with Buyers' products and applications, Buyers should provide adequate design and operating safeguards.

TI does not warrant or represent that any license, either express or implied, is granted under any patent right, copyright, mask work right, or other intellectual property right relating to any combination, machine, or process in which TI components or services are used. Information published by TI regarding third-party products or services does not constitute a license to use such products or services or a warranty or endorsement thereof. Use of such information may require a license from a third party under the patents or other intellectual property of the third party, or a license from TI under the patents or other intellectual property of TI.

Reproduction of significant portions of TI information in TI data books or data sheets is permissible only if reproduction is without alteration and is accompanied by all associated warranties, conditions, limitations, and notices. TI is not responsible or liable for such altered documentation. Information of third parties may be subject to additional restrictions.

Resale of TI components or services with statements different from or beyond the parameters stated by TI for that component or service voids all express and any implied warranties for the associated TI component or service and is an unfair and deceptive business practice. TI is not responsible or liable for any such statements.

Buyer acknowledges and agrees that it is solely responsible for compliance with all legal, regulatory and safety-related requirements concerning its products, and any use of TI components in its applications, notwithstanding any applications-related information or support that may be provided by TI. Buyer represents and agrees that it has all the necessary expertise to create and implement safeguards which anticipate dangerous consequences of failures, monitor failures and their consequences, lessen the likelihood of failures that might cause harm and take appropriate remedial actions. Buyer will fully indemnify TI and its representatives against any damages arising out of the use of any TI components in safety-critical applications.

In some cases, TI components may be promoted specifically to facilitate safety-related applications. With such components, TI's goal is to help enable customers to design and create their own end-product solutions that meet applicable functional safety standards and requirements. Nonetheless, such components are subject to these terms.

No TI components are authorized for use in FDA Class III (or similar life-critical medical equipment) unless authorized officers of the parties have executed a special agreement specifically governing such use.

Only those TI components which TI has specifically designated as military grade or "enhanced plastic" are designed and intended for use in military/aerospace applications or environments. Buyer acknowledges and agrees that any military or aerospace use of TI components which have **not** been so designated is solely at the Buyer's risk, and that Buyer is solely responsible for compliance with all legal and regulatory requirements in connection with such use.

TI has specifically designated certain components as meeting ISO/TS16949 requirements, mainly for automotive use. In any case of use of non-designated products, TI will not be responsible for any failure to meet ISO/TS16949.

Products

Audio	www.ti.com/audio
Amplifiers	amplifier.ti.com
Data Converters	dataconverter.ti.com
DLP® Products	www.dlp.com
DSP	dsp.ti.com
Clocks and Timers	www.ti.com/clocks
Interface	interface.ti.com
Logic	logic.ti.com
Power Mgmt	power.ti.com
Microcontrollers	microcontroller.ti.com
RFID	www.ti-rfid.com
OMAP Applications Processors	www.ti.com/omap
Wireless Connectivity	www.ti.com/wirelessconnectivity

Applications

Automotive and Transportation	www.ti.com/automotive
Communications and Telecom	www.ti.com/communications
Computers and Peripherals	www.ti.com/computers
Consumer Electronics	www.ti.com/consumer-apps
Energy and Lighting	www.ti.com/energy
Industrial	www.ti.com/industrial
Medical	www.ti.com/medical
Security	www.ti.com/security
Space, Avionics and Defense	www.ti.com/space-avionics-defense
Video and Imaging	www.ti.com/video

TI E2E Community

e2e.ti.com