

2.1 W/CH STEREO FILTER-FREE CLASS-D AUDIO POWER AMPLIFIER

FEATURES

- **Output Power By Package:**
 - **QFN:**
 - 2.1 W/Ch Into 4 Ω at 5 V
 - 1.4 W/Ch Into 8 Ω at 5 V
 - 720 mW/Ch Into 8 Ω at 3.6 V
 - **WCSP:**
 - 1.2 W/Ch Into 4 Ω at 5 V⁽¹⁾
 - 1.3 W/Ch Into 8 Ω at 5 V
 - 720 mW/Ch Into 8 Ω at 3.6 V
- **Only Two External Components Required**
- **Power Supply Range: 2.5 V to 5.5 V**
- **Independent Shutdown Control for Each Channel**
- **Selectable Gain of 6, 12, 18, and 24 dB**
- **Internal Pulldown Resistor On Shutdown Pins**
- **High PSRR: 77 dB at 217 Hz**
- **Fast Startup Time (3.5 ms)**
- **Low Supply Current**
- **Low Shutdown Current**
- **Short-Circuit and Thermal Protection**
- **Space Saving Packages**
 - 2,01 mm X 2,01 mm NanoFree™ WCSP (YZH)
 - 4 mm X 4 mm Thin QFN (RTJ) with PowerPAD™

(1) Thermally limited

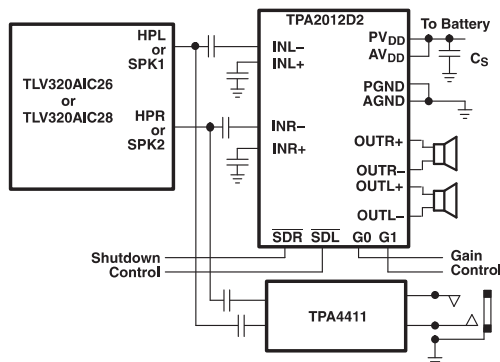

APPLICATIONS

- **Wireless or Cellular Handsets and PDAs**
- **Portable DVD Player**
- **Notebook PC**
- **Portable Radio**
- **Portable Gaming**
- **Educational Toys**
- **USB Speakers**

DESCRIPTION

The TPA2012D2 is a stereo, filter-free, Class-D audio amplifier (class-D amp) available in a WCSP, QFN, or PWP package. The TPA2012D2 only requires two external components for operation.

The TPA2012D2 features independent shutdown controls for each channel. The gain can be selected to 6, 12, 18, or 24 dB utilizing the G0 and G1 gain select pins. High PSRR and differential architecture provide increased immunity to noise and RF rectification. In addition to these features, a fast startup time and small package size make the TPA2012D2 class-D amp an ideal choice for both cellular handsets and PDAs.

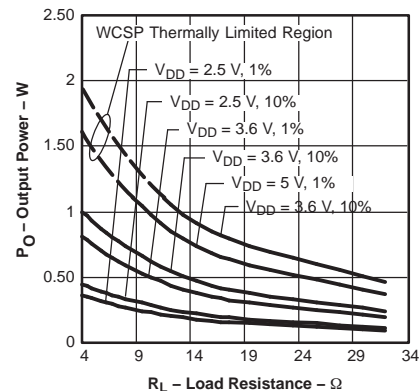

Please be aware that an important notice concerning availability, standard warranty, and use in critical applications of Texas Instruments semiconductor products and disclaimers thereto appears at the end of this data sheet.

NanoFree, PowerPAD are trademarks of Texas Instruments.



These devices have limited built-in ESD protection. The leads should be shorted together or the device placed in conductive foam during storage or handling to prevent electrostatic damage to the MOS gates.

DESCRIPTION (CONTINUED)

The TPA2012D2 is capable of driving 1.4 W/Ch at 5 V or 720 mW/Ch at 3.6 V into 8 Ω . The TPA2012D2 is also capable of driving 4 Ω . The TPA2012D2 is thermally limited in WCSP and may not achieve 2.1 W/Ch for 4 Ω . The maximum output power in the WCSP is determined by the ability of the circuit board to remove heat. The output power versus load resistance graph below shows thermally limited region of the WCSP in relation to the QFN package. The TPA2012D2 provides thermal and short circuit protection.

AVAILABLE OPTIONS

| T_A | PACKAGE | PART NUMBER | SYMBOL |
|---------------|---------------------------------|--------------|--------|
| –40°C to 85°C | 2 mm x 2 mm, 16-ball WCSP (YZH) | TPA2012D2YZH | AKR |
| | 4 mm x 4 mm, 20-pin QFN (RTJ) | TPA2012D2RTJ | AKS |

ABSOLUTE MAXIMUM RATINGS

over operating free-air temperature (unless otherwise noted)⁽¹⁾

| | | VALUE | UNIT | |
|-----------|--------------------------------------|------------------------------|-------------|---|
| V_{SS} | Supply voltage, AVDD, PVDD | In active mode | –0.3 to 6.0 | V |
| | | In shutdown mode | –0.3 to 7.0 | V |
| V_I | Input voltage | –0.3 to $V_{DD} + 0.3$ | V | |
| | Continuous total power dissipation | See Dissipation Rating Table | | |
| T_A | Operating free-air temperature range | –40 to 85 | °C | |
| T_J | Operating junction temperature range | –40 to 150 | °C | |
| T_{stg} | Storage temperature range | –65 to 150 | °C | |

(1) Stresses beyond those listed under *absolute maximum ratings* may cause permanent damage to the device. These are stress ratings only, and functional operation of the device at these or any other conditions beyond those indicated under *recommended operating conditions* is not implied. Exposure to absolute-maximum-rated conditions for extended periods may affect device reliability.

DISSIPATION RATING TABLE

| PACKAGE | $T_A = 25^\circ\text{C}$ POWER RATING ⁽¹⁾ | DERATING FACTOR | $T_A = 75^\circ\text{C}$ POWER RATING | $T_A = 85^\circ\text{C}$ POWER RATING |
|---------|---|--------------------|--|--|
| RTJ | 5.2 W | 41.6 mW/°C | 3.12 W | 2.7 W |
| YZH | 1.2 W | 9.12 mW/°C | 690 mW | 600 mW |

(1) This data was taken using 2 oz trace and copper pad that is soldered directly to a JEDEC standard 4-layer 3 in x 3 in PCB.

RECOMMENDED OPERATING CONDITIONS

| | | | MIN | MAX | UNIT |
|----------|--------------------------------|--|-----|------|------|
| V_{SS} | Supply voltage | AVDD, PVDD | 2.5 | 5.5 | V |
| V_{IH} | High-level input voltage | \overline{SDL} , \overline{SDR} , G0, G1 | 1.3 | | V |
| V_{IL} | Low-level input voltage | \overline{SDL} , \overline{SDR} , G0, G1 | | 0.35 | V |
| T_A | Operating free-air temperature | | –40 | 85 | °C |

ELECTRICAL CHARACTERISTICS

 $T_A = 25^\circ\text{C}$ (unless otherwise noted)

| PARAMETER | | TEST CONDITIONS | MIN | TYP | MAX | UNIT |
|--------------|---|--|------|--------------|------|---------------|
| $ V_{OO} $ | Output offset voltage (measured differentially) | Inputs ac grounded, $A_V = 6$ dB, $V_{DD} = 2.5$ to 5.5 V | | 5 | 25 | mV |
| PSRR | Power supply rejection ratio | $V_{DD} = 2.5$ to 5.5 V | | -75 | -55 | dB |
| V_{icm} | Common-mode input voltage | | 0.5 | $V_{DD}-0.8$ | | V |
| CMRR | Common-mode rejection ratio | Inputs shorted together, $V_{DD} = 2.5$ to 5.5 V | | -69 | -50 | dB |
| $ I_{IH} $ | High-level input current | $V_{DD} = 5.5$ V, $V_I = V_{DD}$ | | | 50 | μA |
| $ I_{IL} $ | Low-level input current | $V_{DD} = 5.5$ V, $V_I = 0$ V | | | 5 | μA |
| I_{DD} | Supply current | $V_{DD} = 5.5$ V, No load or output filter | | 6 | 9 | mA |
| | | $V_{DD} = 3.6$ V, No load or output filter | | 5 | 7.5 | |
| | | $V_{DD} = 2.5$ V, No load or output filter | | 4 | 6 | |
| | | Shutdown mode | | | | 1.5 |
| $r_{DS(on)}$ | Static drain-source on-state resistance | $V_{DD} = 5.5$ V | | 500 | | m Ω |
| | | $V_{DD} = 3.6$ V | | 570 | | |
| | | $V_{DD} = 2.5$ V | | 700 | | |
| | Output impedance in shutdown mode | $V_{(SDR, SDL)} = 0.35$ V | | 2 | | k Ω |
| $f_{(sw)}$ | Switching frequency | $V_{DD} = 2.5$ V to 5.5 V | 250 | 300 | 350 | kHz |
| | Closed-loop voltage gain | $G_0, G_1 = 0.35$ V | 5.5 | 6 | 6.5 | dB |
| | | $G_0 = V_{DD}, G_1 = 0.35$ V | 11.5 | 12 | 12.5 | |
| | | $G_0 = 0.35$ V, $G_1 = V_{DD}$ | 17.5 | 18 | 18.5 | |
| | | $G_0, G_1 = V_{DD}$ | 23.5 | 24 | 24.5 | |

OPERATING CHARACTERISTICS

 $T_A = 25^\circ\text{C}$, $R_L = 8 \Omega$ (unless otherwise noted)

| PARAMETER | | TEST CONDITIONS | | MIN | TYP | MAX | UNIT |
|-----------|--------------------------------------|---|--|-----|-------|-----|---------------|
| P_O | Output power (per channel) | $R_L = 8 \Omega$ | $V_{DD} = 5.0$ V, $f = 1$ kHz, THD = 10% | | 1.4 | | W |
| | | | $V_{DD} = 3.6$ V, $f = 1$ kHz, THD = 10% | | 0.72 | | |
| | | $R_L = 4 \Omega$ | $V_{DD} = 5.0$ V, $f = 1$ kHz, THD = 10% | | 2.1 | | |
| THD+N | Total harmonic distortion plus noise | $P_O = 1$ W, $V_{DD} = 5$ V, $A_V = 6$ dB, $f = 1$ kHz | | | 0.14% | | |
| | | $P_O = 0.5$ W, $V_{DD} = 5$ V, $A_V = 6$ dB, $f = 1$ kHz | | | 0.11% | | |
| | Channel crosstalk | $f = 1$ kHz | | | -85 | | dB |
| k_{SVR} | Supply ripple rejection ratio | $V_{DD} = 5$ V, $A_V = 6$ dB, $f = 217$ Hz | | | -77 | | dB |
| | | $V_{DD} = 3.6$ V, $A_V = 6$ dB, $f = 217$ Hz | | | -73 | | |
| CMRR | Common mode rejection ratio | $V_{DD} = 3.6$ V, $V_{IC} = 1$ V _{pp} , $f = 217$ Hz | | | -69 | | dB |
| | Input impedance | $A_V = 6$ dB | | | 28.1 | | k Ω |
| | | $A_V = 12$ dB | | | 17.3 | | |
| | | $A_V = 18$ dB | | | 9.8 | | |
| | | $A_V = 24$ dB | | | 5.2 | | |
| | Start-up time from shutdown | $V_{DD} = 3.6$ V | | | 3.5 | | ms |
| V_n | Output voltage noise | $V_{DD} = 3.6$ V, $f = 20$ to 20 kHz, Inputs are ac grounded, $A_V = 6$ dB | No weighting | | 35 | | μV |
| | | | A weighting | | 27 | | |

BLOCK DIAGRAM

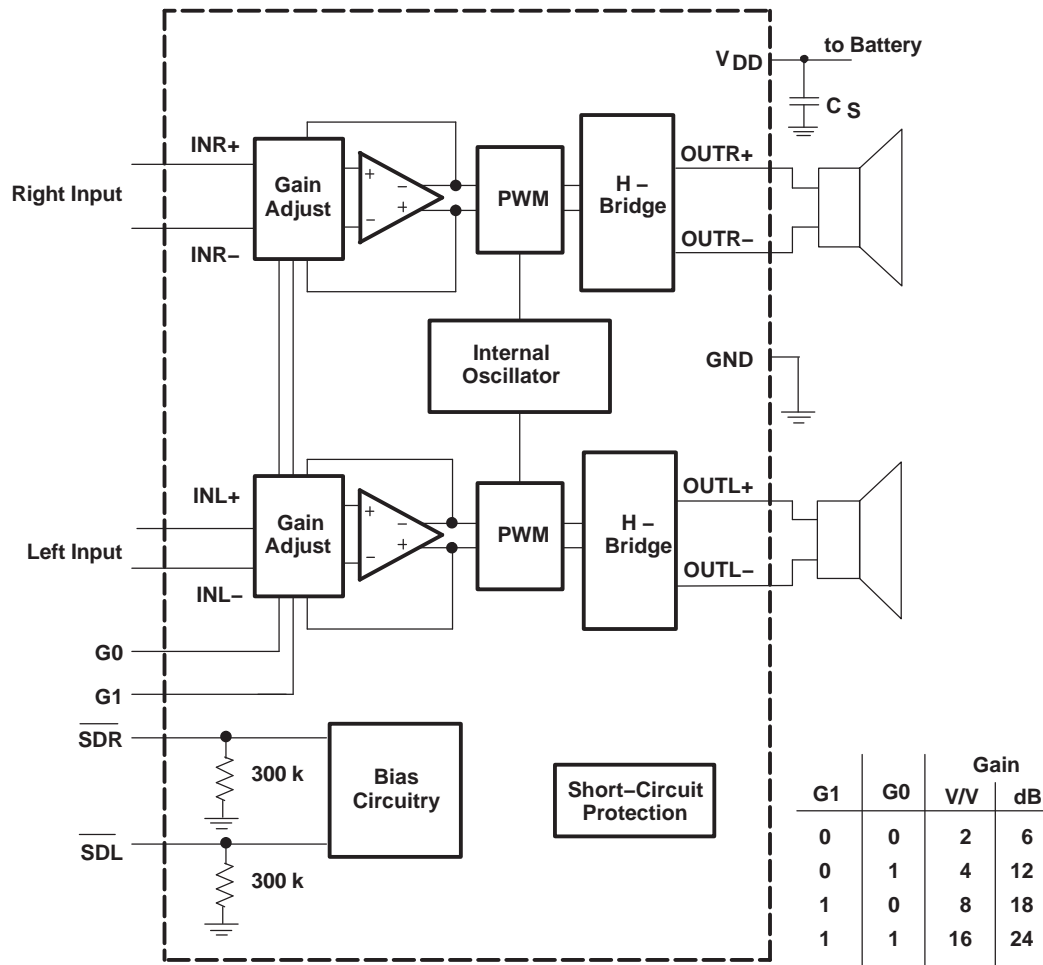

Terminal Functions

| TERMINAL | | | I/O | DESCRIPTION |
|-------------------------|-------|------|-----|--|
| NAME | QFN | WCSP | | |
| INR+ | 16 | D1 | I | Right channel positive input |
| INR- | 17 | C1 | I | Right channel negative input |
| INL+ | 20 | A1 | I | Left channel positive input |
| INL- | 19 | B1 | I | Left channel negative input |
| $\overline{\text{SDR}}$ | 8 | B3 | I | Right channel shutdown terminal (active low) |
| $\overline{\text{SDL}}$ | 7 | B4 | I | Left channel shutdown terminal (active low) |
| G0 | 15 | C2 | I | Gain select (LSB) |
| G1 | 1 | B2 | I | Gain select (MSB) |
| PVDD | 3, 13 | A2 | I | Power supply (Must be same voltage as AVDD) |
| AVDD | 9 | D2 | I | Analog supply (Must be same voltage as PVDD) |
| PGND | 4, 12 | C4 | I | Power ground |
| AGND | 18 | C3 | I | Analog ground |
| OUTR+ | 14 | D3 | O | Right channel positive differential output |
| OUTR- | 11 | D4 | O | Right channel negative differential output |
| OUTL+ | 2 | A3 | O | Left channel positive differential output |
| OUTL- | 5 | A4 | O | Left channel negative differential output |
| NC | 6, 10 | N/A | | No internal connection |
| Thermal Pad | | | | Connect the thermal pad of QFN or PWP package to PCB GND |

**WCSP PIN OUT
TOP VIEW**

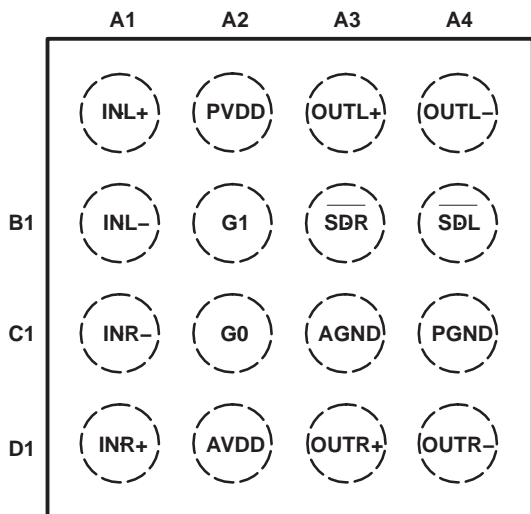

**RTJ PIN OUT
TOP VIEW**

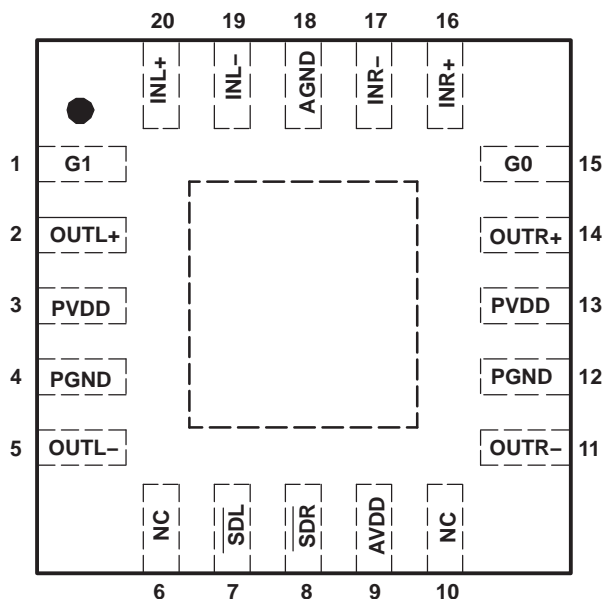

TEST SET-UP FOR GRAPHS (per channel)

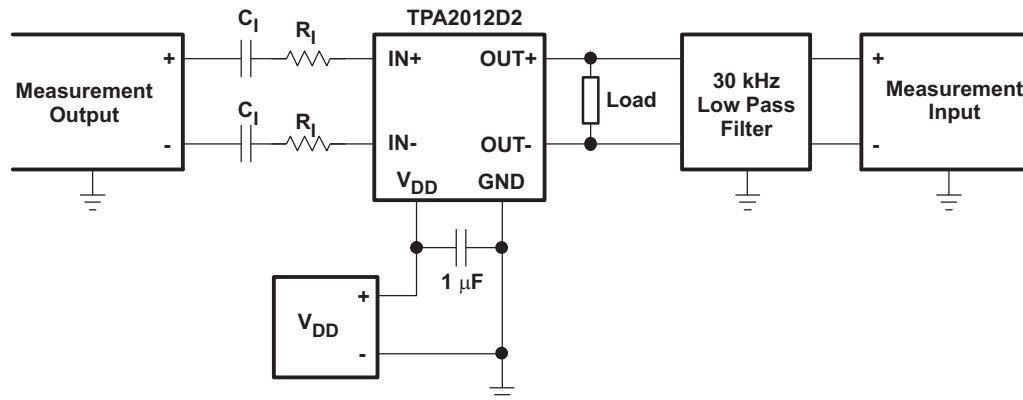

- (1) C_1 was Shorted for any Common-Mode input voltage measurement.
- (2) A 33- μ H inductor was placed in series with the load resistor to emulate a small speaker for efficiency measurements.
- (3) The 30-kHz low-pass filter is required even if the analyzer has an internal low-pass filter. An RC low pass filter (100 Ω , 47 nF) is used on each output for the data sheet graphs.

TYPICAL CHARACTERISTICS

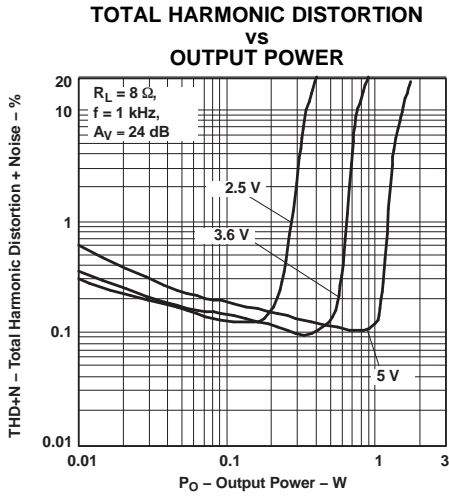

Figure 1.

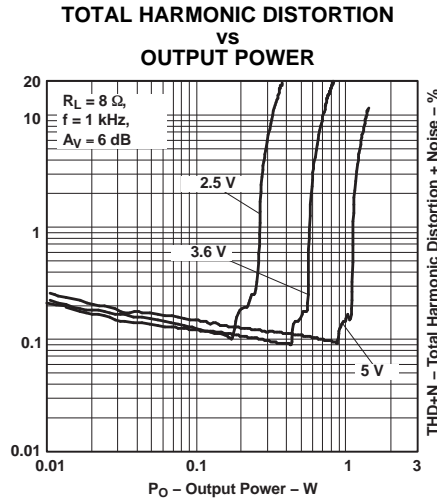

Figure 2.

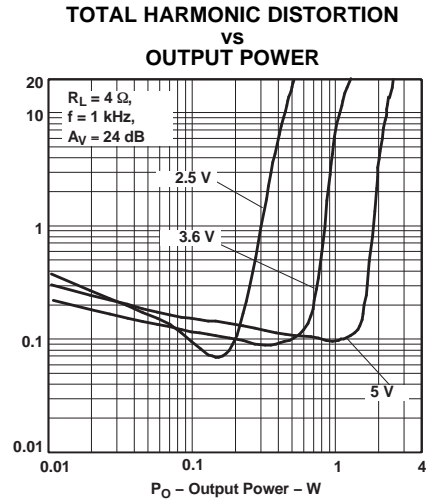

Figure 3.

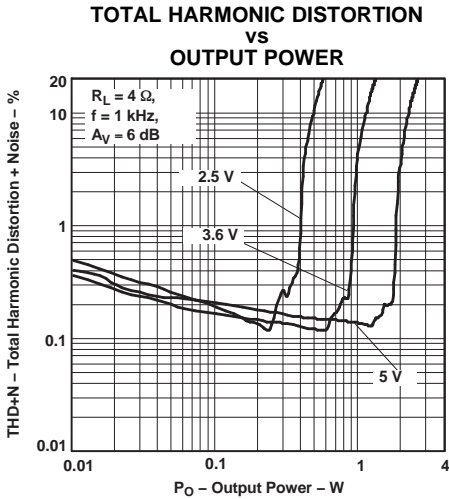

Figure 4.

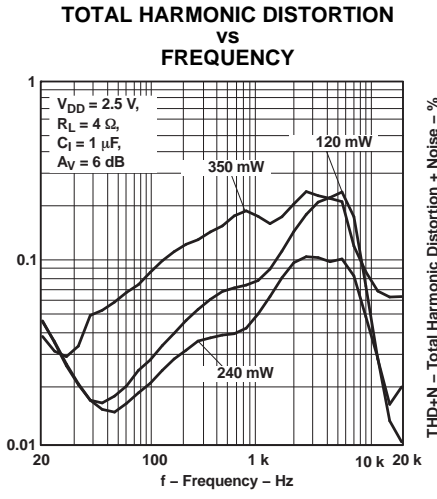

Figure 5.

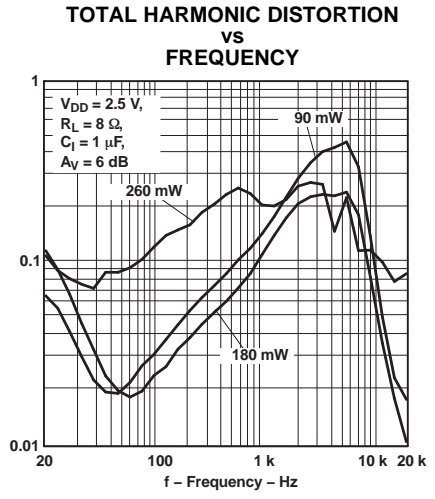

Figure 6.

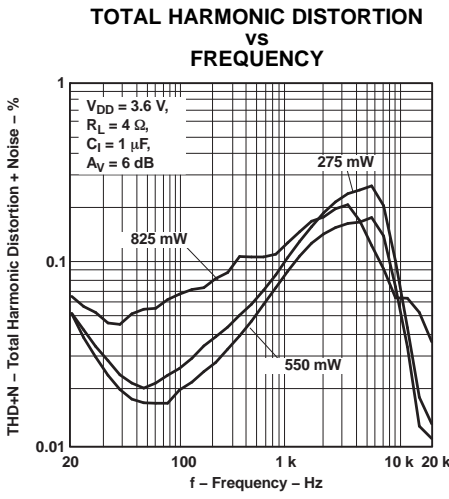

Figure 7.

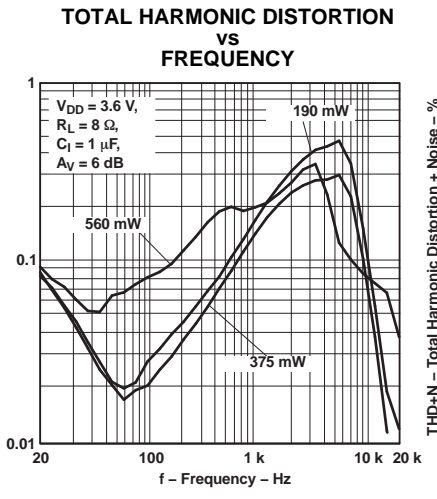

Figure 8.

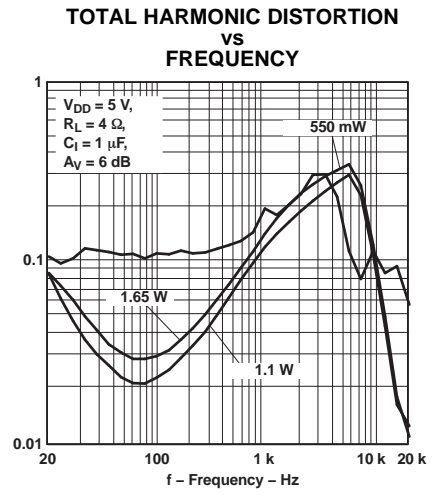

Figure 9.

TYPICAL CHARACTERISTICS (continued)

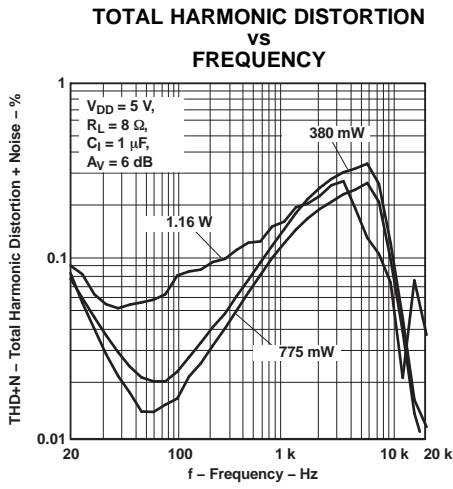

Figure 10.

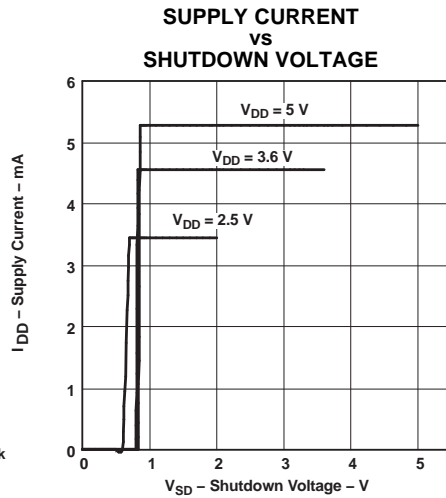

Figure 11.

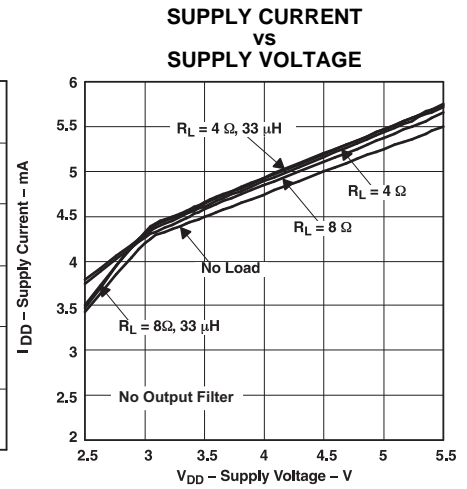

Figure 12.

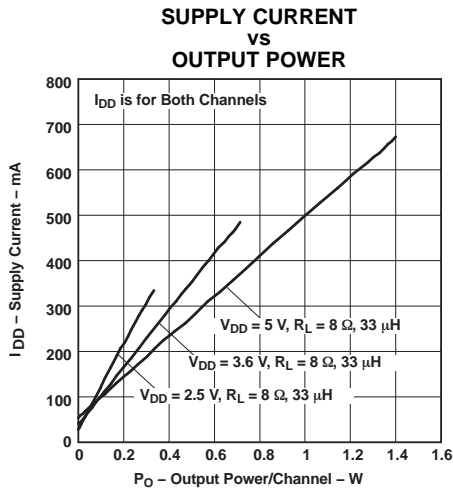

Figure 13.

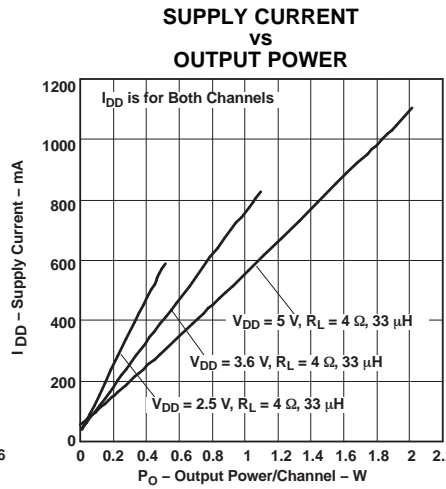

Figure 14.

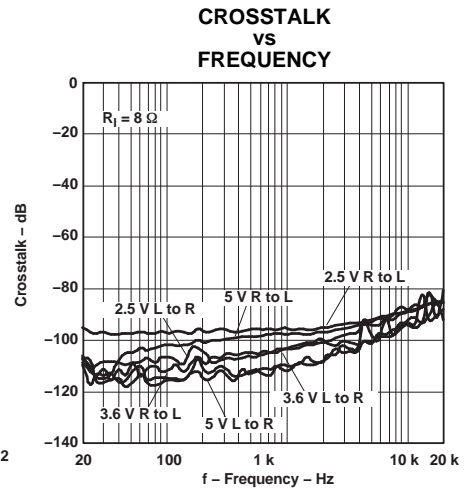

Figure 15.

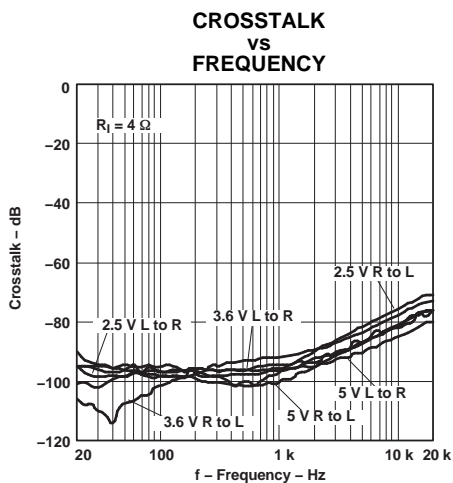

Figure 16.

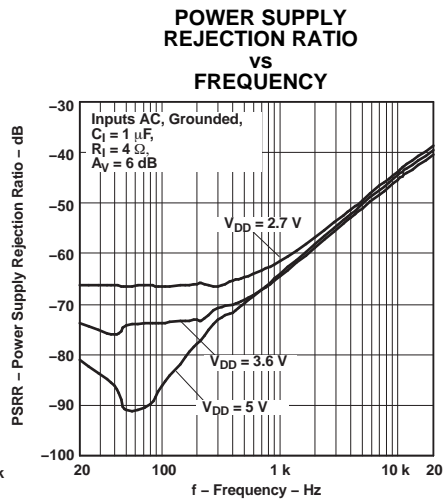

Figure 17.

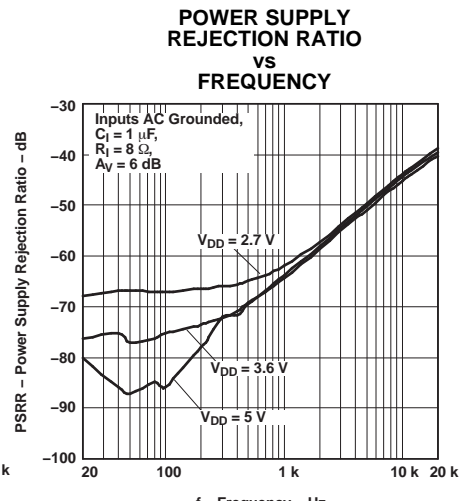

Figure 18.

TYPICAL CHARACTERISTICS (continued)

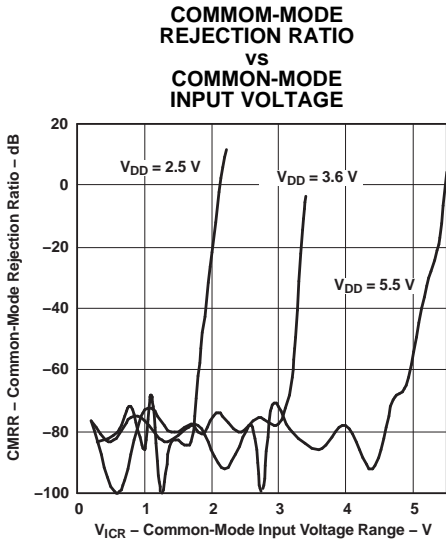

Figure 19.

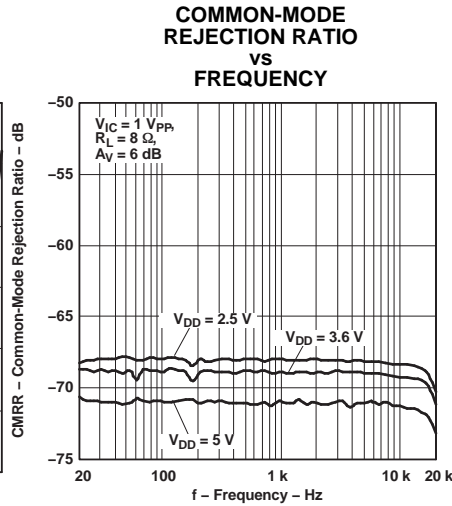

Figure 20.

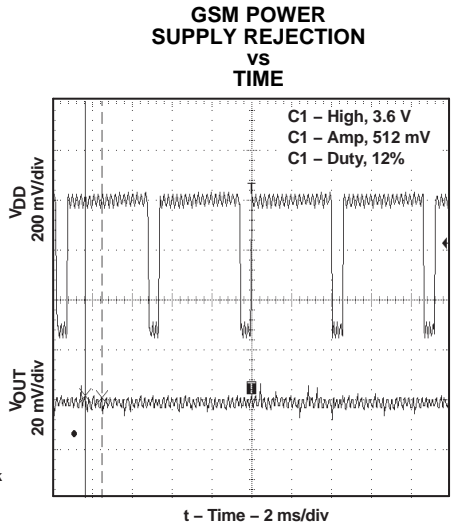

Figure 21.

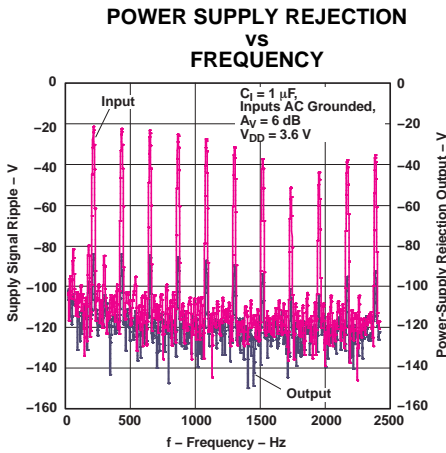

Figure 22.

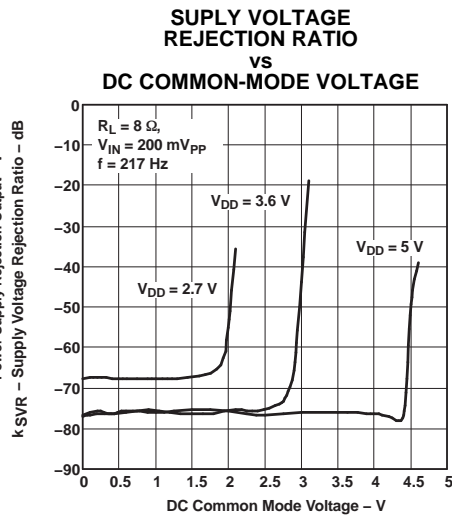

Figure 23.

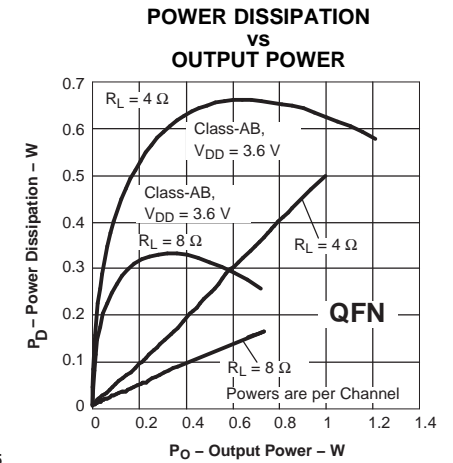

Figure 24.

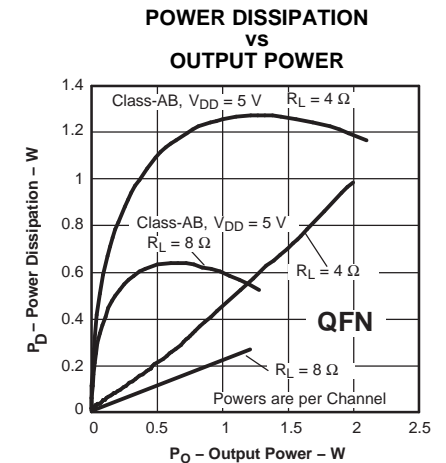

Figure 25.

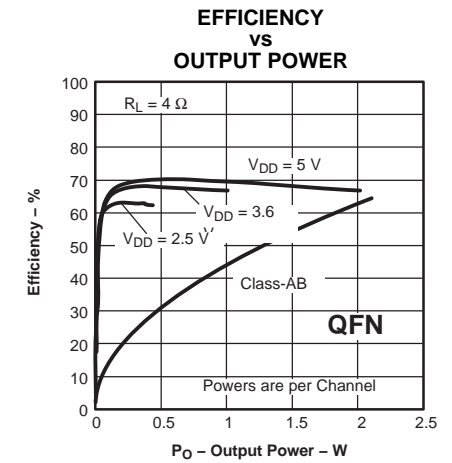

Figure 26.

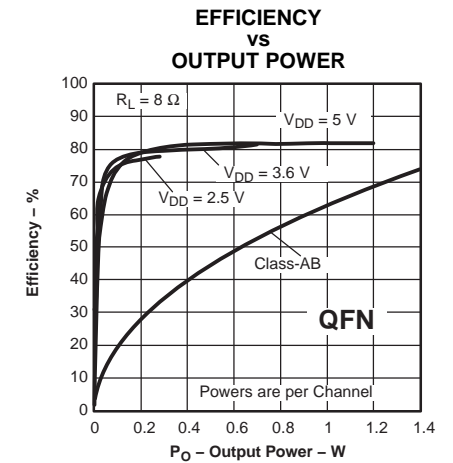

Figure 27.

TYPICAL CHARACTERISTICS (continued)

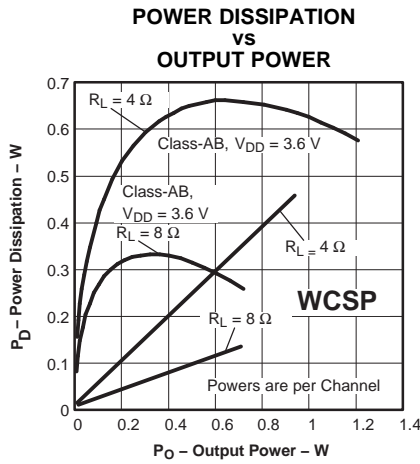

Figure 28.

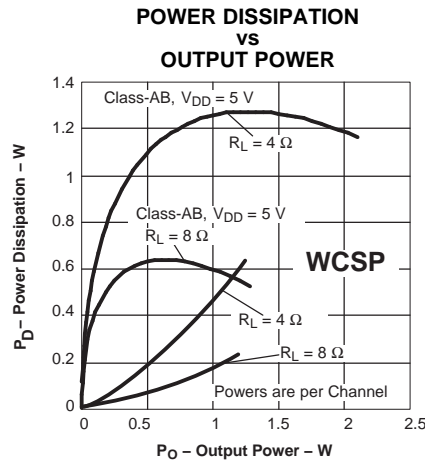

Figure 29.

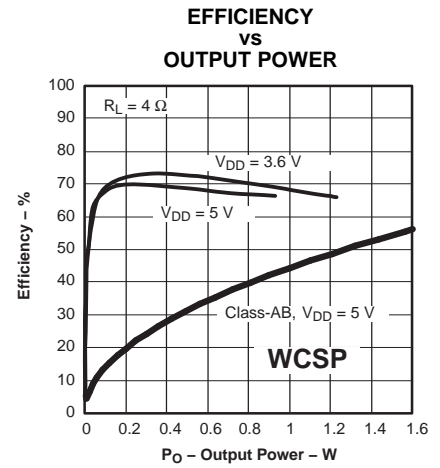

Figure 30.

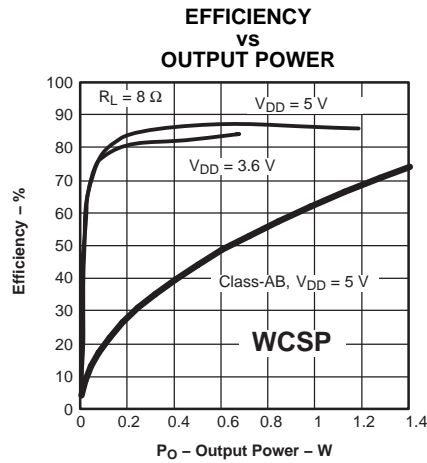

Figure 31.

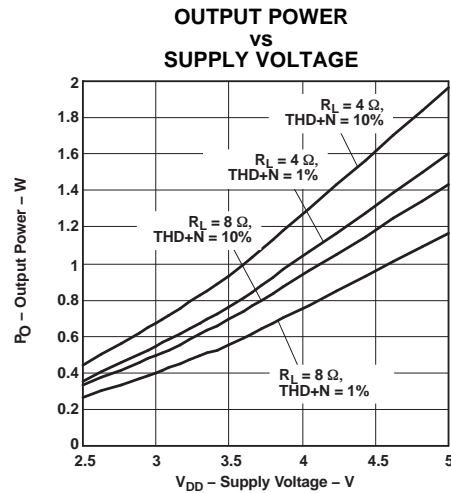
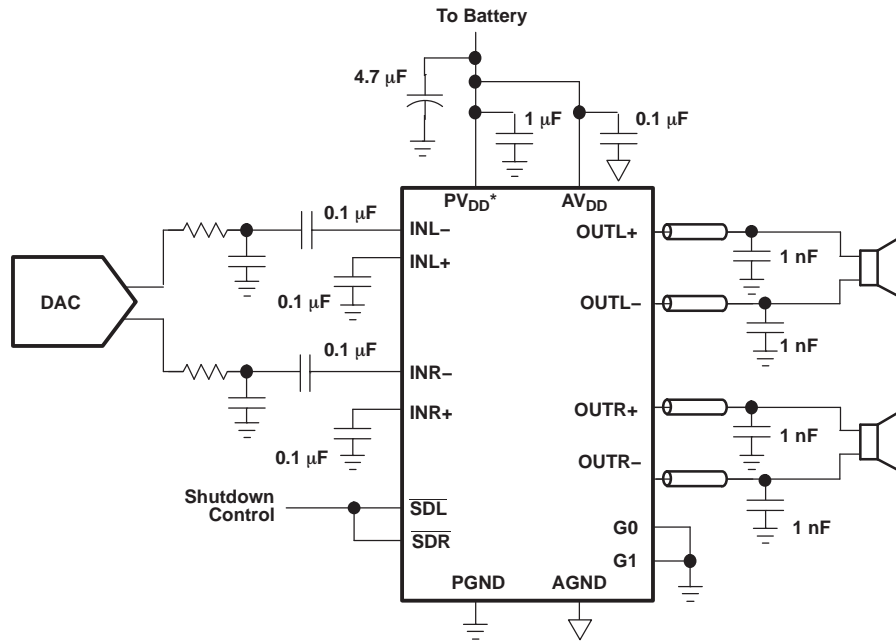

Figure 32.

APPLICATION INFORMATION



* For QFN, an additional capacitor is recommended for the second PV_{DD} pin.

Figure 33. Typical Application Circuit

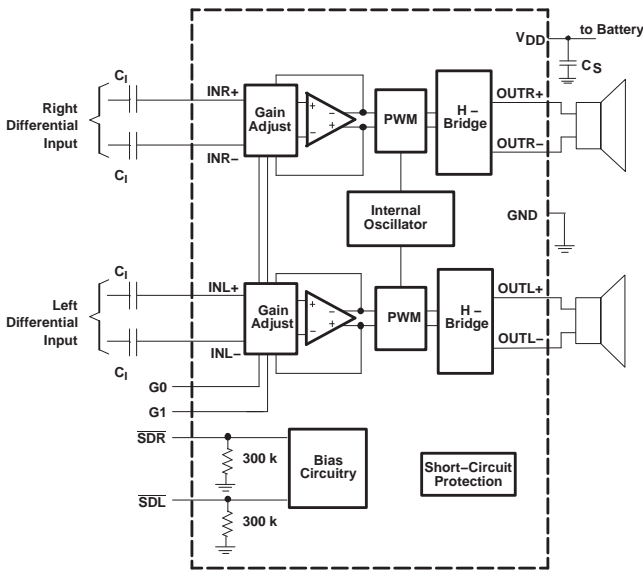

Figure 34. TPA2012D2 Application Schematic With Differential Input and Input Capacitors

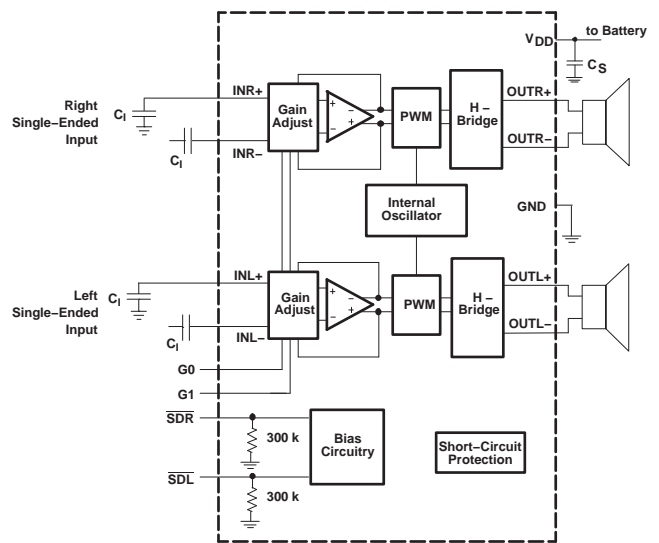

Figure 35. TPA2012D2 Application Schematic With Single-Ended Input

Decoupling Capacitor (C_S)

The TPA2012D2 is a high-performance Class-D audio amplifier that requires adequate power supply decoupling to ensure the efficiency is high and total harmonic distortion (THD) is low. For higher frequency transients, spikes, or digital hash on the line a good low equivalent-series-resistance (ESR) ceramic capacitor, typically 1 μF , placed as close as possible to the device PV_{DD} lead works best. Placing this decoupling capacitor close to the TPA2012D2 is important for the efficiency of the Class-D amplifier, because any resistance or inductance in the trace between the device and the capacitor can cause a loss in efficiency. For filtering lower-frequency noise signals, a 4.7 μF or greater capacitor placed near the audio power amplifier would also help, but it is not required in most applications because of the high PSRR of this device.

Table 1. Gain Setting

| G1 | G0 | GAIN (V/V) | GAIN (dB) | INPUT IMPEDANCE (R _I) (k Ω) |
|----|----|---------------|--------------|---|
| 0 | 0 | 2 | 6 | 28.1 |
| 0 | 1 | 4 | 12 | 17.3 |
| 1 | 0 | 8 | 18 | 9.8 |
| 1 | 1 | 16 | 24 | 5.2 |

Input Capacitors (C_I)

The TPA2012D2 does not require input coupling capacitors if the design uses a differential source that is biased from 0.5 V to $V_{\text{DD}} - 0.8$ V. If the input signal is not biased within the recommended common-mode input range, if high pass filtering is needed (see [Figure 34](#)), or if using a single-ended source (see [Figure 35](#)), input coupling capacitors are required.

The input capacitors and input resistors form a high-pass filter with the corner frequency, f_c , determined in [Equation 1](#).

$$f_c = \frac{1}{(2\pi R_I C_I)} \quad (1)$$

The value of the input capacitor is important to consider as it directly affects the bass (low frequency) performance of the circuit. Speakers in wireless phones cannot usually respond well to low frequencies, so the corner frequency can be set to block low frequencies in this application. Not using input capacitors can increase output offset.

[Equation 2](#) is used to solve for the input coupling capacitance.

$$C_I = \frac{1}{(2\pi R_I f_c)} \quad (2)$$

If the corner frequency is within the audio band, the capacitors should have a tolerance of $\pm 10\%$ or better, because any mismatch in capacitance causes an impedance mismatch at the corner frequency and below.

BOARD LAYOUT

In making the pad size for the WCSP balls, it is recommended that the layout use nonsolder mask defined (NSMD) land. With this method, the solder mask opening is made larger than the desired land area, and the opening size is defined by the copper pad width. Figure 36 and Table 2 shows the appropriate diameters for a WCSP layout. The TPA2012D2 evaluation module (EVM) layout is shown in the next section as a layout example.

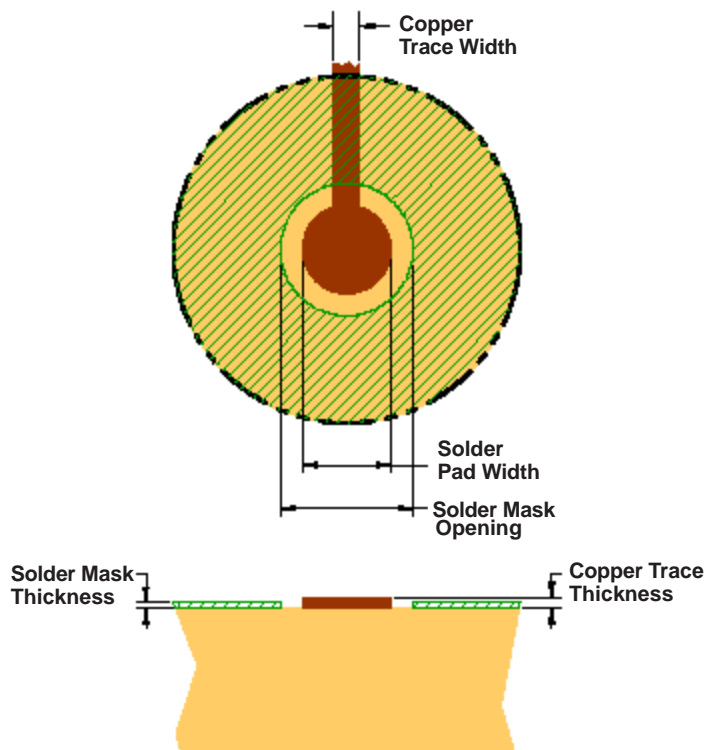

Figure 36. Land Pattern Dimensions

Table 2. Land Pattern Dimensions⁽¹⁾⁽²⁾⁽³⁾⁽⁴⁾

| SOLDER PAD DEFINITIONS | COPPER PAD | SOLDER MASK ⁽⁵⁾ OPENING | COPPER THICKNESS | STENCIL ⁽⁶⁾⁽⁷⁾ OPENING | STENCIL THICKNESS |
|-------------------------------|---|--|------------------------------|--|-------------------------|
| Nonsolder mask defined (NSMD) | 275 μm (+0.0, -25 μm) | 375 μm (+0.0, -25 μm) | 1 oz max (32 μm) | 275 μm x 275 μm Sq. (rounded corners) | 125 μm thick |

- (1) Circuit traces from NSMD defined PWB lands should be 75 μm to 100 μm wide in the exposed area inside the solder mask opening. Wider trace widths reduce device stand off and impact reliability.
- (2) Best reliability results are achieved when the PWB laminate glass transition temperature is above the operating the range of the intended application.
- (3) Recommend solder paste is Type 3 or Type 4.
- (4) For a PWB using a Ni/Au surface finish, the gold thickness should be less 0.5 μm to avoid a reduction in thermal fatigue performance.
- (5) Solder mask thickness should be less than 20 μm on top of the copper circuit pattern
- (6) Best solder stencil performance is achieved using laser cut stencils with electro polishing. Use of chemically etched stencils results in inferior solder paste volume control.
- (7) Trace routing away from WCSP device should be balanced in X and Y directions to avoid unintentional component movement due to solder wetting forces.

Component Location

Place all the external components very close to the TPA2012D2. Placing the decoupling capacitor, C_S , close to the TPA2012D2 is important for the efficiency of the Class-D amplifier. Any resistance or inductance in the trace between the device and the capacitor can cause a loss in efficiency.

Trace Width

Recommended trace width at the solder balls is 75 μm to 100 μm to prevent solder wicking onto wider PCB traces.

For high current pins (PV_{DD} , PGND, and audio output pins) of the TPA2012D2, use 100- μm trace widths at the solder balls and at least 500- μm PCB traces to ensure proper performance and output power for the device.

For the remaining signals of the TPA2012D2, use 75- μm to 100- μm trace widths at the solder balls. The audio input pins (INR+/- and INL+/-) must run side-by-side to maximize common-mode noise cancellation.

EFFICIENCY AND THERMAL INFORMATION

The maximum ambient temperature depends on the heat-sinking ability of the PCB system. The derating factor for the packages are shown in the dissipation rating table. Converting this to θ_{JA} for the QFN package:

$$\theta_{JA} = \frac{1}{\text{Derating Factor}} = \frac{1}{0.041} = 24^{\circ}\text{C/W} \quad (3)$$

Given θ_{JA} of 24 $^{\circ}\text{C/W}$, the maximum allowable junction temperature of 150 $^{\circ}\text{C}$, and the maximum internal dissipation of 1.5W (0.75 W per channel) for 2.1 W per channel, 4- Ω load, 5-V supply, from [Figure 25](#), the maximum ambient temperature can be calculated with the following equation.

$$T_{A\text{Max}} = T_{J\text{Max}} - \theta_{JA} P_{D\text{max}} = 150 - 24 (1.5) = 114^{\circ}\text{C} \quad (4)$$

[Equation 4](#) shows that the calculated maximum ambient temperature is 114 $^{\circ}\text{C}$ at maximum power dissipation with a 5-V supply and 4- Ω a load. The TPA2012D2 is designed with thermal protection that turns the device off when the junction temperature surpasses 150 $^{\circ}\text{C}$ to prevent damage to the IC. Also, using speakers more resistive than 4- Ω dramatically increases the thermal performance by reducing the output current and increasing the efficiency of the amplifier.

OPERATION WITH DACs AND CODECS

In using Class-D amplifiers with CODECs and DACs, sometimes there is an increase in the output noise floor from the audio amplifier. This occurs when mixing of the output frequencies of the CODEC/DAC mix with the switching frequencies of the audio amplifier input stage. The noise increase can be solved by placing a low-pass filter between the CODEC/DAC and audio amplifier. This filters off the high frequencies that cause the problem and allow proper performance. See [Figure 33](#) for the block diagram.

FILTER FREE OPERATION AND FERRITE BEAD FILTERS

A ferrite bead filter can often be used if the design is failing radiated emissions without an LC filter and the frequency sensitive circuit is greater than 1 MHz. This filter functions well for circuits that just have to pass FCC and CE because FCC and CE only test radiated emissions greater than 30 MHz. When choosing a ferrite bead, choose one with high impedance at high frequencies, and very low impedance at low frequencies. In addition, select a ferrite bead with adequate current rating to prevent distortion of the output signal.

Use an LC output filter if there are low frequency (< 1 MHz) EMI sensitive circuits and/or there are long leads from amplifier to speaker.

[Figure 37](#) shows typical ferrite bead and LC output filters.

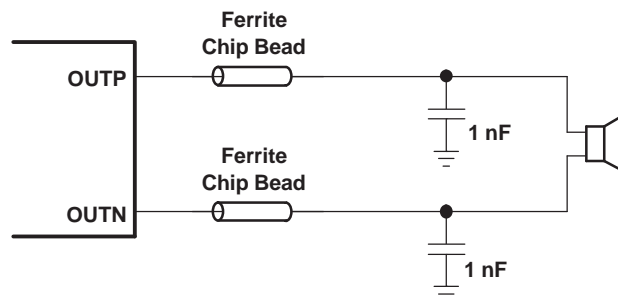

Figure 37. Typical Ferrite Chip Bead Filter (Chip bead example: TDK: MPZ1608S221A)

PACKAGING INFORMATION

| Orderable Device | Status (1) | Package Type | Package Drawing | Pins | Package Qty | Eco Plan (2) | Lead/Ball Finish (6) | MSL Peak Temp (3) | Op Temp (°C) | Device Marking (4/5) | Samples |
|------------------|---------------|--------------|-----------------|------|-------------|-------------------------|-------------------------|----------------------|--------------|-------------------------|-------------------------|
| TPA2012D2RTJR | ACTIVE | QFN | RTJ | 20 | 3000 | Green (RoHS & no Sb/Br) | CU NIPDAU | Level-2-260C-1 YEAR | -40 to 85 | AKS | Samples |
| TPA2012D2RTJRG4 | ACTIVE | QFN | RTJ | 20 | 3000 | Green (RoHS & no Sb/Br) | CU NIPDAU | Level-2-260C-1 YEAR | -40 to 85 | AKS | Samples |
| TPA2012D2RTJT | ACTIVE | QFN | RTJ | 20 | 250 | Green (RoHS & no Sb/Br) | CU NIPDAU | Level-2-260C-1 YEAR | -40 to 85 | AKS | Samples |
| TPA2012D2RTJTG4 | ACTIVE | QFN | RTJ | 20 | 250 | Green (RoHS & no Sb/Br) | CU NIPDAU | Level-2-260C-1 YEAR | -40 to 85 | AKS | Samples |
| TPA2012D2YZHR | ACTIVE | DSBGA | YZH | 16 | 3000 | Green (RoHS & no Sb/Br) | SNAGCU | Level-1-260C-UNLIM | -40 to 85 | AKR | Samples |
| TPA2012D2YZHT | ACTIVE | DSBGA | YZH | 16 | 250 | Green (RoHS & no Sb/Br) | SNAGCU | Level-1-260C-UNLIM | -40 to 85 | AKR | Samples |

(1) The marketing status values are defined as follows:

ACTIVE: Product device recommended for new designs.

LIFEBUY: TI has announced that the device will be discontinued, and a lifetime-buy period is in effect.

NRND: Not recommended for new designs. Device is in production to support existing customers, but TI does not recommend using this part in a new design.

PREVIEW: Device has been announced but is not in production. Samples may or may not be available.

OBSOLETE: TI has discontinued the production of the device.

(2) Eco Plan - The planned eco-friendly classification: Pb-Free (RoHS), Pb-Free (RoHS Exempt), or Green (RoHS & no Sb/Br) - please check <http://www.ti.com/productcontent> for the latest availability information and additional product content details.

TBD: The Pb-Free/Green conversion plan has not been defined.

Pb-Free (RoHS): TI's terms "Lead-Free" or "Pb-Free" mean semiconductor products that are compatible with the current RoHS requirements for all 6 substances, including the requirement that lead not exceed 0.1% by weight in homogeneous materials. Where designed to be soldered at high temperatures, TI Pb-Free products are suitable for use in specified lead-free processes.

Pb-Free (RoHS Exempt): This component has a RoHS exemption for either 1) lead-based flip-chip solder bumps used between the die and package, or 2) lead-based die adhesive used between the die and leadframe. The component is otherwise considered Pb-Free (RoHS compatible) as defined above.

Green (RoHS & no Sb/Br): TI defines "Green" to mean Pb-Free (RoHS compatible), and free of Bromine (Br) and Antimony (Sb) based flame retardants (Br or Sb do not exceed 0.1% by weight in homogeneous material)

(3) MSL, Peak Temp. - The Moisture Sensitivity Level rating according to the JEDEC industry standard classifications, and peak solder temperature.

(4) There may be additional marking, which relates to the logo, the lot trace code information, or the environmental category on the device.

(5) Multiple Device Markings will be inside parentheses. Only one Device Marking contained in parentheses and separated by a "~" will appear on a device. If a line is indented then it is a continuation of the previous line and the two combined represent the entire Device Marking for that device.

⁽⁶⁾ Lead/Ball Finish - Orderable Devices may have multiple material finish options. Finish options are separated by a vertical ruled line. Lead/Ball Finish values may wrap to two lines if the finish value exceeds the maximum column width.

Important Information and Disclaimer: The information provided on this page represents TI's knowledge and belief as of the date that it is provided. TI bases its knowledge and belief on information provided by third parties, and makes no representation or warranty as to the accuracy of such information. Efforts are underway to better integrate information from third parties. TI has taken and continues to take reasonable steps to provide representative and accurate information but may not have conducted destructive testing or chemical analysis on incoming materials and chemicals. TI and TI suppliers consider certain information to be proprietary, and thus CAS numbers and other limited information may not be available for release.

In no event shall TI's liability arising out of such information exceed the total purchase price of the TI part(s) at issue in this document sold by TI to Customer on an annual basis.

TAPE AND REEL INFORMATION

QUADRANT ASSIGNMENTS FOR PIN 1 ORIENTATION IN TAPE

*All dimensions are nominal

| Device | Package Type | Package Drawing | Pins | SPQ | Reel Diameter (mm) | Reel Width W1 (mm) | A0 (mm) | B0 (mm) | K0 (mm) | P1 (mm) | W (mm) | Pin1 Quadrant |
|---------------|--------------|-----------------|------|------|--------------------|--------------------|---------|---------|---------|---------|--------|---------------|
| TPA2012D2RTJR | QFN | RTJ | 20 | 3000 | 330.0 | 12.4 | 4.25 | 4.25 | 1.15 | 8.0 | 12.0 | Q2 |
| TPA2012D2RTJR | QFN | RTJ | 20 | 3000 | 330.0 | 12.4 | 4.25 | 4.25 | 1.15 | 8.0 | 12.0 | Q2 |
| TPA2012D2RTJT | QFN | RTJ | 20 | 250 | 180.0 | 12.4 | 4.25 | 4.25 | 1.15 | 8.0 | 12.0 | Q2 |
| TPA2012D2RTJT | QFN | RTJ | 20 | 250 | 180.0 | 12.4 | 4.25 | 4.25 | 1.15 | 8.0 | 12.0 | Q2 |
| TPA2012D2YZHR | DSBGA | YZH | 16 | 3000 | 180.0 | 8.4 | 2.18 | 2.18 | 0.81 | 4.0 | 8.0 | Q1 |
| TPA2012D2YZHT | DSBGA | YZH | 16 | 250 | 180.0 | 8.4 | 2.18 | 2.18 | 0.81 | 4.0 | 8.0 | Q1 |

TAPE AND REEL BOX DIMENSIONS

*All dimensions are nominal

| Device | Package Type | Package Drawing | Pins | SPQ | Length (mm) | Width (mm) | Height (mm) |
|---------------|--------------|-----------------|------|------|-------------|------------|-------------|
| TPA2012D2RTJR | QFN | RTJ | 20 | 3000 | 367.0 | 367.0 | 35.0 |
| TPA2012D2RTJR | QFN | RTJ | 20 | 3000 | 367.0 | 367.0 | 35.0 |
| TPA2012D2RTJT | QFN | RTJ | 20 | 250 | 210.0 | 185.0 | 35.0 |
| TPA2012D2RTJT | QFN | RTJ | 20 | 250 | 210.0 | 185.0 | 35.0 |
| TPA2012D2YZHR | DSBGA | YZH | 16 | 3000 | 182.0 | 182.0 | 20.0 |
| TPA2012D2YZHT | DSBGA | YZH | 16 | 250 | 182.0 | 182.0 | 20.0 |

RTJ (S-PWQFN-N20)

PLASTIC QUAD FLATPACK NO-LEAD

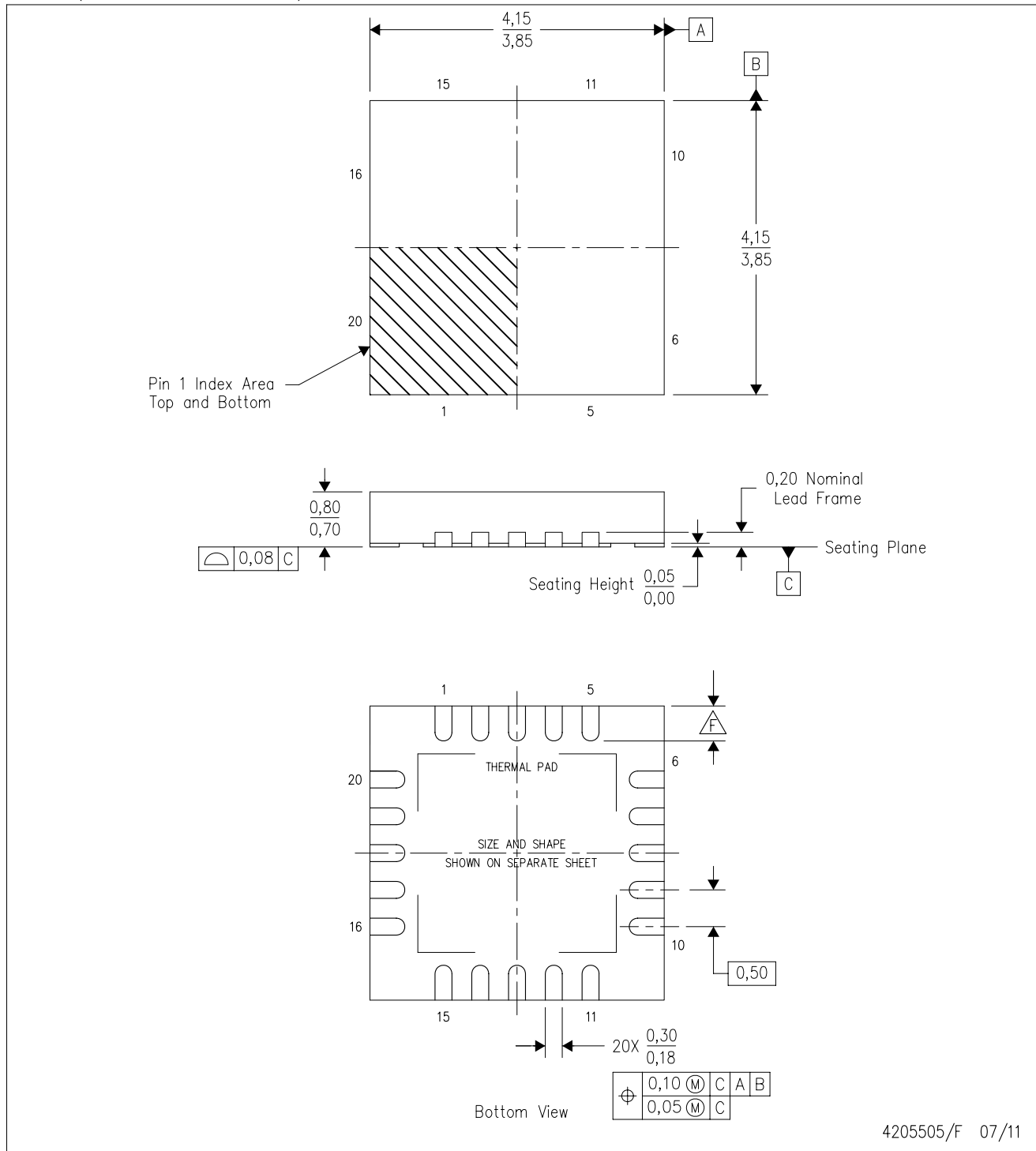

- NOTES:
- A. All linear dimensions are in millimeters. Dimensioning and tolerancing per ASME Y14.5-1994.
 - B. This drawing is subject to change without notice.
 - C. QFN (Quad Flatpack No-Lead) package configuration.
 - D. The package thermal pad must be soldered to the board for thermal and mechanical performance.
 - E. See the additional figure in the Product Data Sheet for details regarding the exposed thermal pad features and dimensions.
- ⚠ Check thermal pad mechanical drawing in the product datasheet for nominal lead length dimensions.

RTJ (S-PWQFN-N20)

PLASTIC QUAD FLATPACK NO-LEAD

THERMAL INFORMATION

This package incorporates an exposed thermal pad that is designed to be attached directly to an external heatsink. The thermal pad must be soldered directly to the printed circuit board (PCB). After soldering, the PCB can be used as a heatsink. In addition, through the use of thermal vias, the thermal pad can be attached directly to the appropriate copper plane shown in the electrical schematic for the device, or alternatively, can be attached to a special heatsink structure designed into the PCB. This design optimizes the heat transfer from the integrated circuit (IC).

For information on the Quad Flatpack No-Lead (QFN) package and its advantages, refer to Application Report, QFN/SON PCB Attachment, Texas Instruments Literature No. SLUA271. This document is available at www.ti.com.

The exposed thermal pad dimensions for this package are shown in the following illustration.

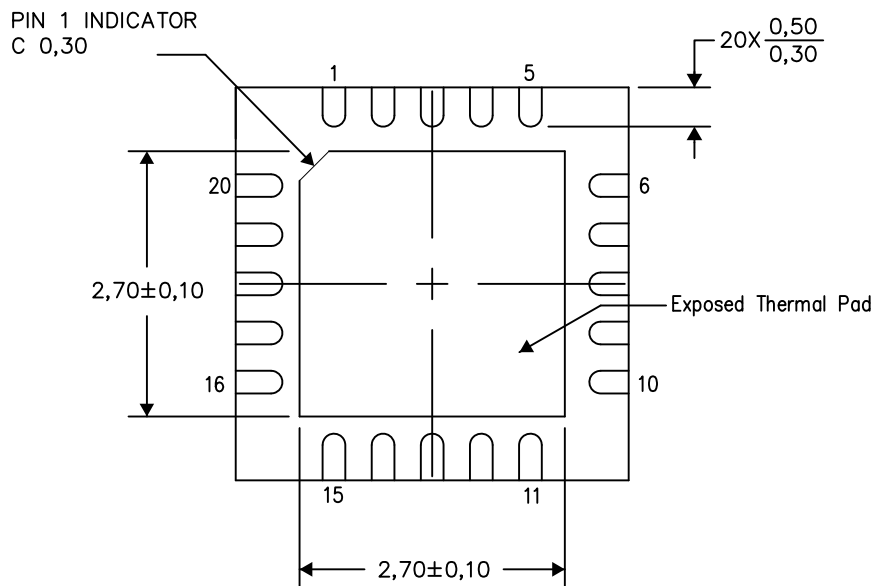

Bottom View

Exposed Thermal Pad Dimensions

4206256-2/V 05/15

NOTE: All linear dimensions are in millimeters

RTJ (S-PWQFN-N20)

PLASTIC QUAD FLATPACK NO-LEAD

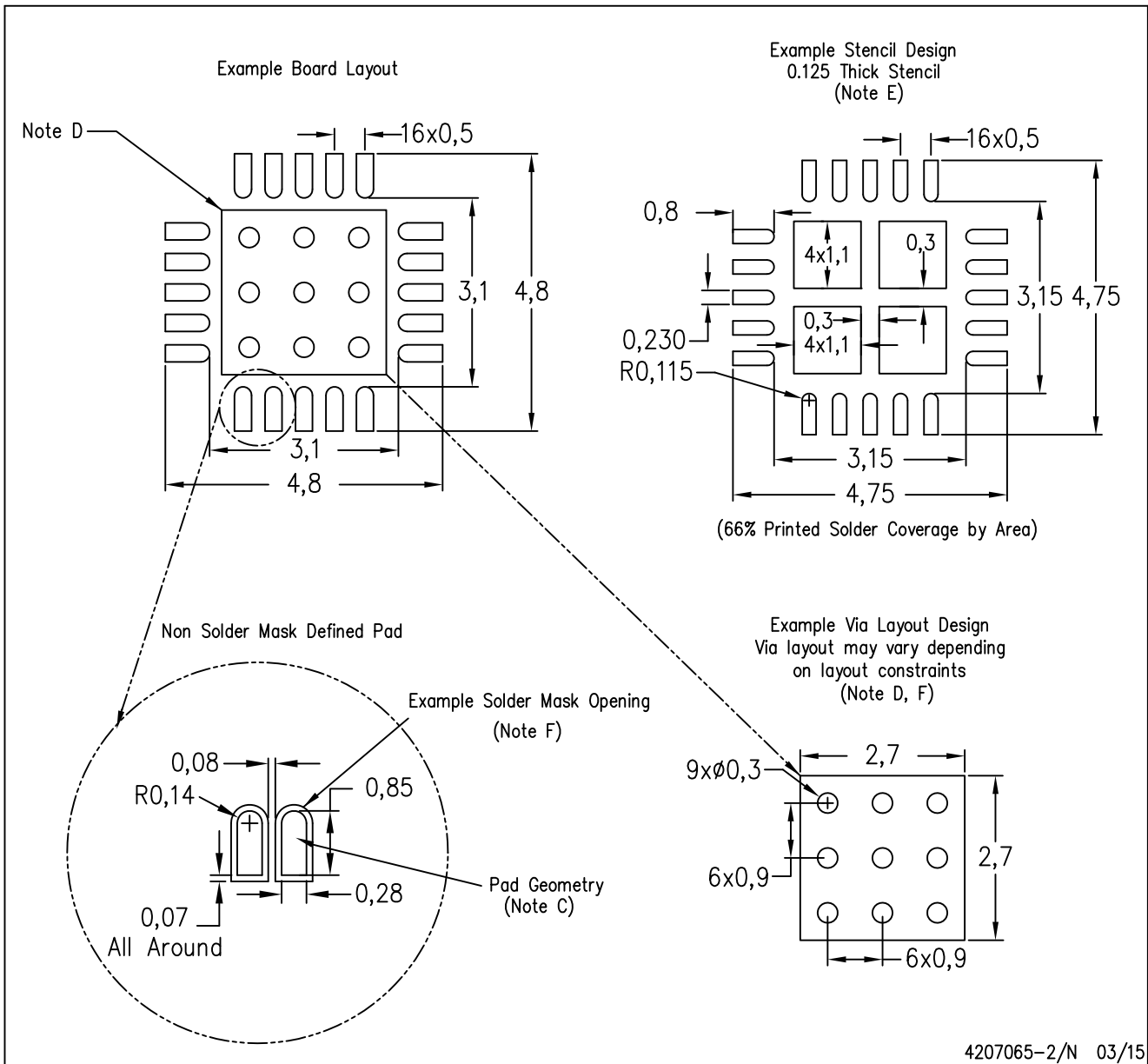

- NOTES:
- A. All linear dimensions are in millimeters.
 - B. This drawing is subject to change without notice.
 - C. Publication IPC-7351 is recommended for alternate designs.
 - D. This package is designed to be soldered to a thermal pad on the board. Refer to Application Note, Quad Flat-Pack Packages, Texas Instruments Literature No. SLUA271, and also the Product Data Sheets for specific thermal information, via requirements, and recommended board layout. These documents are available at www.ti.com <<http://www.ti.com>>.
 - E. Laser cutting apertures with trapezoidal walls and also rounding corners will offer better paste release. Customers should contact their board assembly site for stencil design recommendations. Refer to IPC 7525 for stencil design considerations.
 - F. Customers should contact their board fabrication site for recommended solder mask tolerances and via tenting recommendations for vias placed in the thermal pad.

YZH (S-XBGA-N16)

DIE-SIZE BALL GRID ARRAY

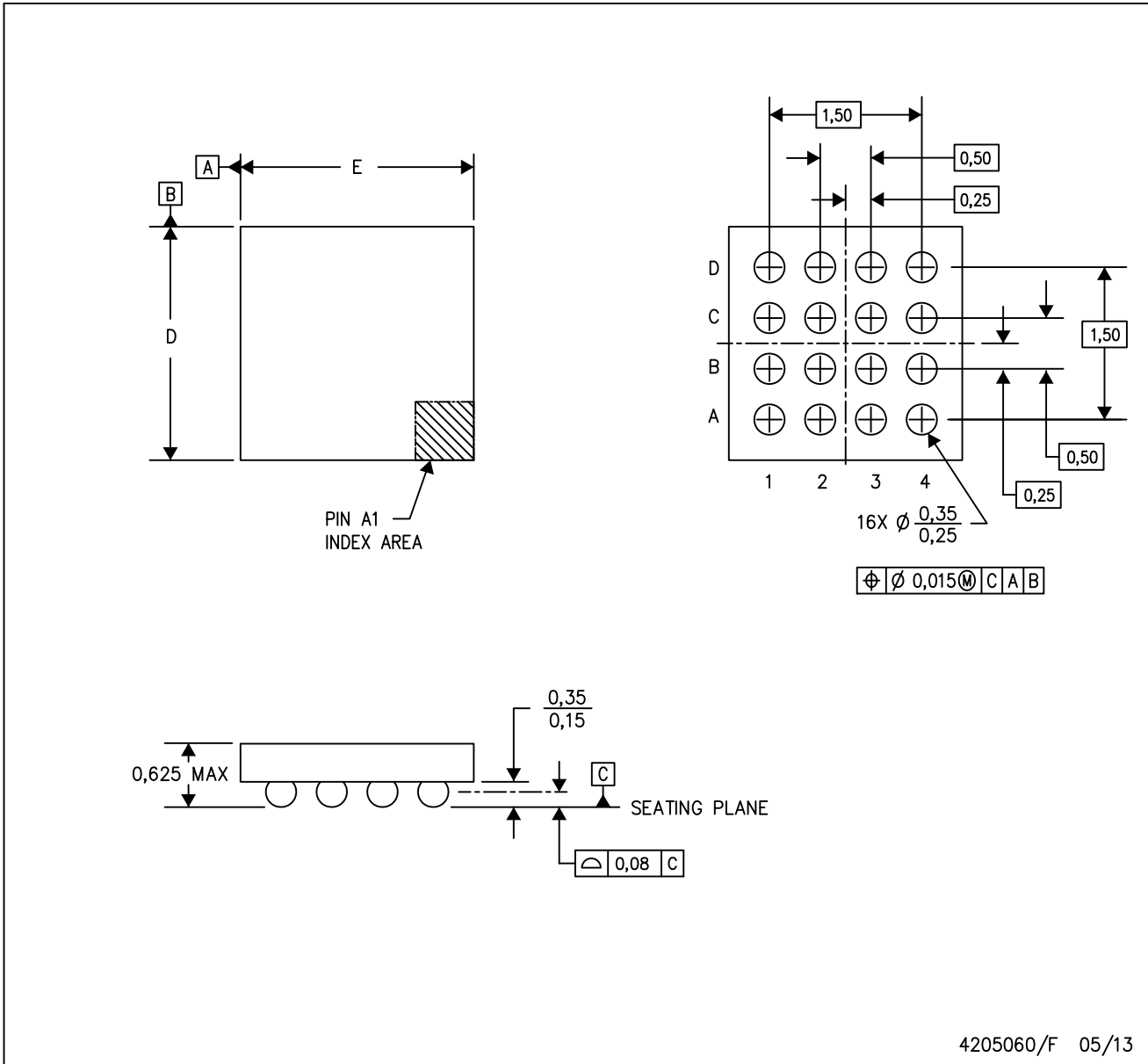

- NOTES:
- A. All linear dimensions are in millimeters.
 - B. This drawing is subject to change without notice.
 - C. NanoFree™ package configuration.

IMPORTANT NOTICE

Texas Instruments Incorporated and its subsidiaries (TI) reserve the right to make corrections, enhancements, improvements and other changes to its semiconductor products and services per JESD46, latest issue, and to discontinue any product or service per JESD48, latest issue. Buyers should obtain the latest relevant information before placing orders and should verify that such information is current and complete. All semiconductor products (also referred to herein as "components") are sold subject to TI's terms and conditions of sale supplied at the time of order acknowledgment.

TI warrants performance of its components to the specifications applicable at the time of sale, in accordance with the warranty in TI's terms and conditions of sale of semiconductor products. Testing and other quality control techniques are used to the extent TI deems necessary to support this warranty. Except where mandated by applicable law, testing of all parameters of each component is not necessarily performed.

TI assumes no liability for applications assistance or the design of Buyers' products. Buyers are responsible for their products and applications using TI components. To minimize the risks associated with Buyers' products and applications, Buyers should provide adequate design and operating safeguards.

TI does not warrant or represent that any license, either express or implied, is granted under any patent right, copyright, mask work right, or other intellectual property right relating to any combination, machine, or process in which TI components or services are used. Information published by TI regarding third-party products or services does not constitute a license to use such products or services or a warranty or endorsement thereof. Use of such information may require a license from a third party under the patents or other intellectual property of the third party, or a license from TI under the patents or other intellectual property of TI.

Reproduction of significant portions of TI information in TI data books or data sheets is permissible only if reproduction is without alteration and is accompanied by all associated warranties, conditions, limitations, and notices. TI is not responsible or liable for such altered documentation. Information of third parties may be subject to additional restrictions.

Resale of TI components or services with statements different from or beyond the parameters stated by TI for that component or service voids all express and any implied warranties for the associated TI component or service and is an unfair and deceptive business practice. TI is not responsible or liable for any such statements.

Buyer acknowledges and agrees that it is solely responsible for compliance with all legal, regulatory and safety-related requirements concerning its products, and any use of TI components in its applications, notwithstanding any applications-related information or support that may be provided by TI. Buyer represents and agrees that it has all the necessary expertise to create and implement safeguards which anticipate dangerous consequences of failures, monitor failures and their consequences, lessen the likelihood of failures that might cause harm and take appropriate remedial actions. Buyer will fully indemnify TI and its representatives against any damages arising out of the use of any TI components in safety-critical applications.

In some cases, TI components may be promoted specifically to facilitate safety-related applications. With such components, TI's goal is to help enable customers to design and create their own end-product solutions that meet applicable functional safety standards and requirements. Nonetheless, such components are subject to these terms.

No TI components are authorized for use in FDA Class III (or similar life-critical medical equipment) unless authorized officers of the parties have executed a special agreement specifically governing such use.

Only those TI components which TI has specifically designated as military grade or "enhanced plastic" are designed and intended for use in military/aerospace applications or environments. Buyer acknowledges and agrees that any military or aerospace use of TI components which have **not** been so designated is solely at the Buyer's risk, and that Buyer is solely responsible for compliance with all legal and regulatory requirements in connection with such use.

TI has specifically designated certain components as meeting ISO/TS16949 requirements, mainly for automotive use. In any case of use of non-designated products, TI will not be responsible for any failure to meet ISO/TS16949.

Products

| | |
|------------------------------|--|
| Audio | www.ti.com/audio |
| Amplifiers | amplifier.ti.com |
| Data Converters | dataconverter.ti.com |
| DLP® Products | www.dlp.com |
| DSP | dsp.ti.com |
| Clocks and Timers | www.ti.com/clocks |
| Interface | interface.ti.com |
| Logic | logic.ti.com |
| Power Mgmt | power.ti.com |
| Microcontrollers | microcontroller.ti.com |
| RFID | www.ti-rfid.com |
| OMAP Applications Processors | www.ti.com/omap |
| Wireless Connectivity | www.ti.com/wirelessconnectivity |

Applications

| | |
|-------------------------------|--|
| Automotive and Transportation | www.ti.com/automotive |
| Communications and Telecom | www.ti.com/communications |
| Computers and Peripherals | www.ti.com/computers |
| Consumer Electronics | www.ti.com/consumer-apps |
| Energy and Lighting | www.ti.com/energy |
| Industrial | www.ti.com/industrial |
| Medical | www.ti.com/medical |
| Security | www.ti.com/security |
| Space, Avionics and Defense | www.ti.com/space-avionics-defense |
| Video and Imaging | www.ti.com/video |

TI E2E Community

e2e.ti.com