



## 25-mW DIRECTPATH™ STEREO HEADPHONE AMPLIFIER WITH POP SUPPRESSION

### FEATURES

- **Patented DirectPath™ Technology Eliminates Need for DC-Blocking Capacitors**
  - Outputs Biased at 0 V
  - Excellent Low Frequency Fidelity
- **Active Click and Pop Suppression**
- **HI-Z Output Mode Allows Sharing Output Jack**
- **2.1 mA Typical Supply Current**
- **Fully Differential Inputs Reduce System Noise**
  - Also Configurable as Single-Ended Inputs
- **SGND Pin Eliminates Ground Loop Noise**
- **Constant Maximum Output Power from 2.3 V to 5.5 V Supply**
  - Simplifies Design to Prevent Acoustic Shock
- **Microsoft™ Windows Vista™ Compliant**
- **100 dB Power Supply Noise Rejection**
- **Wide Power Supply Range: 2.3 V to 5.5 V**
- **Gain Settings: 0 dB and 6 dB**
- **Short-Circuit and Thermal-Overload Protection**
- **±8 kV HBM ESD Protected Outputs**
- **Small Package Available**
  - 16-Ball, 1.6 x 1.6 mm, 0.4 mm Pitch WCSP

### APPLICATIONS

- Smart Phones / Cellular Phones
- Portable Media / MP3 Players
- Notebook Computers
- Portable Gaming

### DESCRIPTION

The TPA6136A2 (sometimes referred to as TPA6136) is a DirectPath™ stereo headphone amplifier that eliminates the need for external dc-blocking output capacitors. Differential stereo inputs and built-in resistors set the device gain, further reducing external component count. Gain is selectable at 0 dB or 6 dB. The amplifier drives 25 mW into 16 Ω speakers from a single 2.3 V supply. The TPA6136A2 (TPA6136) provides a constant maximum output power independent of the supply voltage, thus facilitating the design for prevention of acoustic shock.

The TPA6136A2 (TPA6136) features fully differential inputs with an integrated low pass filter to reduce system noise pickup between the audio source and the headphone amplifier and to reduce DAC out-of-band noise. The high power supply noise rejection performance and differential architecture provides increased RF noise immunity. For single-ended input signals, connect INL+ and INR+ to ground.

The device has built-in pop suppression circuitry to completely eliminate disturbing pop noise during turn-on and turn-off. The amplifier outputs have short-circuit and thermal-overload protection along with ±8 kV HBM ESD protection, simplifying end equipment compliance to the IEC 61000-4-2 ESD standard.

The TPA6136A2 (TPA6136) operates from a single 2.3 V to 5.5 V supply with 2.1 mA of typical supply current. Shutdown mode reduces supply current to less than 1 μA.

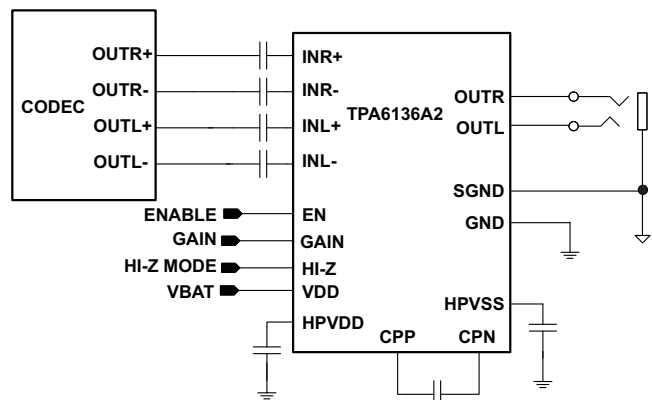

Please be aware that an important notice concerning availability, standard warranty, and use in critical applications of Texas Instruments semiconductor products and disclaimers thereto appears at the end of this data sheet.

DirectPath is a trademark of Texas Instruments.

Windows Vista is a trademark of Microsoft Corporation.

# TPA6136A2

SLOS621A–JULY 2009–REVISED AUGUST 2009

www.ti.com



These devices have limited built-in ESD protection. The leads should be shorted together or the device placed in conductive foam during storage or handling to prevent electrostatic damage to the MOS gates.

## FUNCTIONAL BLOCK DIAGRAM

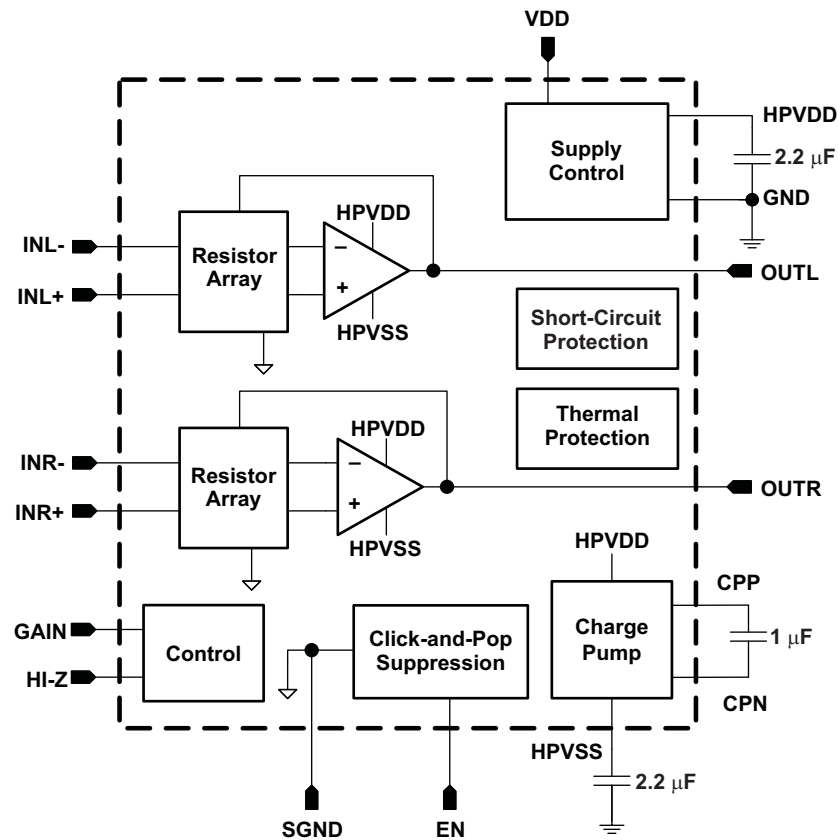

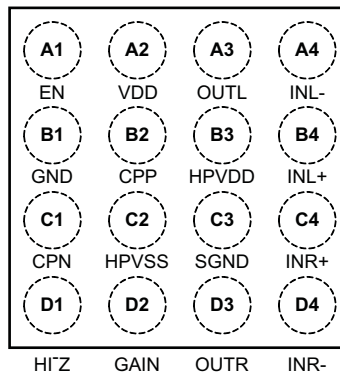
**DEVICE PINOUT**
**WCSP PACKAGE  
(TOP VIEW)**

**PIN FUNCTIONS**

PIN		I/O/P	PIN DESCRIPTION
NAME	WCSP		
INL-	A4	I	Inverting left input for differential signals; left input for single-ended signals
INL+	B4	I	Non-inverting left input for differential signals. Connect to ground for single-ended input applications
INR+	C4	I	Non-inverting right input for differential signals. Connect to ground for single-ended input applications
INR-	D4	I	Inverting right input for differential signals; right input for single-ended signals
OUTR	D3	O	Right headphone amplifier output. Connect to right terminal of headphone jack
HI-Z	D1	I	Output impedance select. Set to logic LOW for normal operation and to logic HIGH for high output impedance
GAIN	D2	I	Gain select. Set to logic LOW for a gain of 0dB and to logic HIGH for a gain of 6dB
HPVSS	C2	P	Charge pump output and negative power supply for output amplifiers; connect 1 $\mu$ F capacitor to GND
CPN	C1	P	Charge pump negative flying cap. Connect to negative side of 1 $\mu$ F capacitor between CPP and CPN
GND	B1	P	Ground
CPP	B2	P	Charge pump positive flying cap. Connect to positive side of 1 $\mu$ F capacitor between CPP and CPN
HPVDD	B3	P	Positive power supply for headphone amplifiers. Connect to a 2.2 $\mu$ F capacitor. Do not connect to VDD
EN	A1	I	Amplifier enable. Connect to logic low to shutdown; connect to logic high to activate
VDD	A2	P	Positive power supply for TPA6136A2
SGND	C3	I	Amplifier reference voltage. Connect to ground terminal of headphone jack
OUTL	A3	O	Left headphone amplifier output. Connect to left terminal of headphone jack

# TPA6136A2

SLOS621A–JULY 2009–REVISED AUGUST 2009

www.ti.com

## BOARD LAYOUT CONCEPT

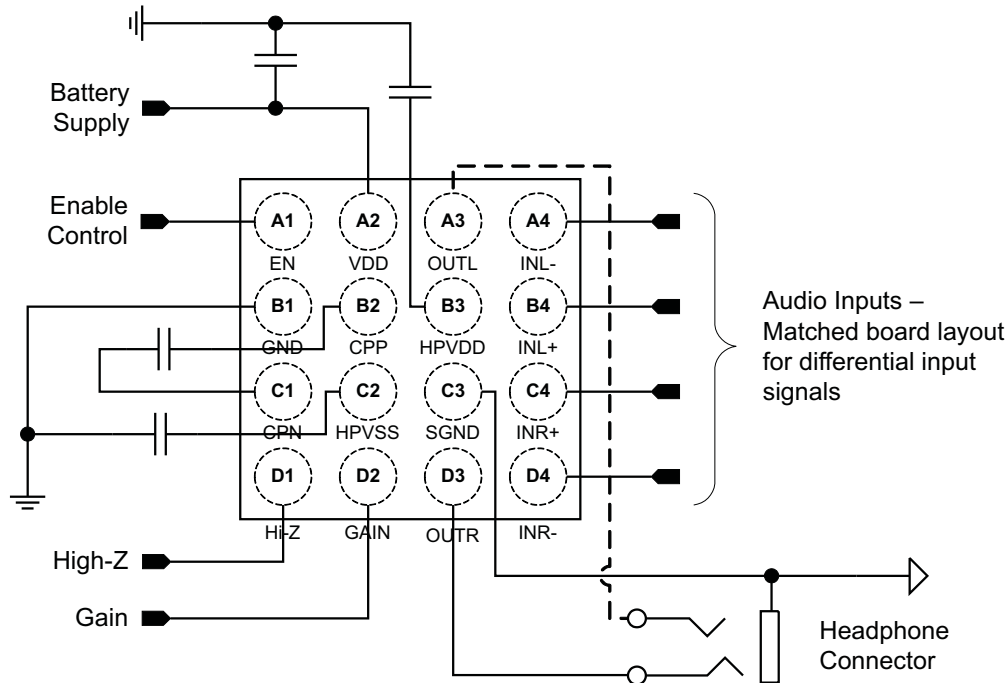

## ABSOLUTE MAXIMUM RATINGS

over operating free-air temperature range,  $T_A = 25^\circ\text{C}$  (unless otherwise noted)

		VALUE / UNIT
Supply voltage, VDD		–0.3 V to 6.0 V
Headphone amplifier supply voltage, HPVDD (do not connect to external supply)		–0.3 V to 1.9 V
$V_I$	Input voltage (INR+, INR–, INL+, INL–)	1.4 $V_{RMS}$
Output continuous total power dissipation		See Dissipation Rating Table
$T_A$	Operating free-air temperature range	–40°C to 85°C
$T_J$	Operating junction temperature range	–40°C to 150°C
$T_{stg}$	Storage temperature range	–65°C to 150°C
ESD Protection – HBM	OUTL, OUTR	8 kV
	All Other Pins	2 kV

## ORDERING GUIDE

$T_A$	PACKAGED DEVICES <sup>(1)</sup>	PART NUMBER <sup>(2)</sup>	SYMBOL
–40°C to 85°C	16–ball, 1.6 mm x 1.6 mm WCSP	TPA6136A2YFFR	AOWI
		TPA6136A2YFFT	

(1) For the most current package and ordering information, see the Package Option Addendum at the end of this document, or see the TI Web site at [www.ti.com](http://www.ti.com).

(2) The YFF package is only available taped and reeled. The suffix “R” indicates a reel of 3000; the suffix “T” indicates a reel of 250.

**DISSIPATION RATINGS TABLE**

PACKAGE	T <sub>A</sub> ≤ 25°C POWER RATING	DERATING FACTOR <sup>(1)</sup>	T <sub>A</sub> = 70°C POWER RATING	T <sub>A</sub> = 85°C POWER RATING
YFF (WCSP)	1250 mW	10 mW/°C	800 mW	650 mW

(1) See JEDEC Standard 51-3 for Low-K board, JEDEC Standard 51-7 for High-K board, and JEDEC Standard 51-12 for using package thermal information. See JEDEC document page for downloadable copies: <http://www.jedec.org/download/default.cfm>.

**RECOMMENDED OPERATING CONDITIONS**

	MIN	MAX	UNIT
Supply voltage, VDD	2.3	5.5	V
V <sub>IH</sub> High-level input voltage; EN, GAIN, HI-Z	1.3		V
V <sub>IL</sub> Low-level input voltage; EN, GAIN, HI-Z		0.6	V
Voltage applied to Output; OUTR, OUTL (when EN = 0 V)	−0.3	3.6	V
Voltage applied to Output; OUTR, OUTL (when EN ≥ 1.3 V and HI-Z ≥ 1.3 V)	−1.8	1.8	V
T <sub>A</sub> Operating free-air temperature	−40	85	°C

**ELECTRICAL CHARACTERISTICS**

T<sub>A</sub> = 25°C (unless otherwise noted)

PARAMETER	TEST CONDITIONS	MIN	TYP	MAX	UNIT
Output offset voltage		−0.5		0.5	mV
Power supply rejection ratio	V <sub>DD</sub> = 2.3 V to 5.5 V		100		dB
High-level output current (EN, GAIN, HI-Z)				1	μA
Low-level output current (EN, GAIN, HI-Z)				1	μA
Supply Current	V <sub>DD</sub> = 2.3 V, No load, EN = V <sub>DD</sub>		2.1	2.8	mA
	V <sub>DD</sub> = 3.6 V, No load, EN = V <sub>DD</sub>		2.1	2.8	
	V <sub>DD</sub> = 5.5 V, No load, EN = V <sub>DD</sub>		2.2	2.9	
	V <sub>DD</sub> = 2.3 V to 5.5 V, No load, EN = HI-Z = V,		0.7	1.2	
Shutdown Supply Current	EN = 0 V, V <sub>DD</sub> = 2.3 V to 5.5 V		0.7	1.2	μA

# TPA6136A2

SLOS621A–JULY 2009–REVISED AUGUST 2009

[www.ti.com](http://www.ti.com)

## OPERATING CHARACTERISTICS

 $V_{DD} = 3.6\text{ V}$ ,  $T_A = 25^\circ\text{C}$ ,  $R_L = 16\ \Omega$  (unless otherwise noted)

PARAMETER		TEST CONDITIONS	MIN	TYP	MAX	UNIT
P <sub>O</sub>	Output power <sup>(1)</sup> (Outputs in phase)	THD = 1%, f = 1 kHz		25		mW
		THD = 1%, f = 1 kHz, R <sub>L</sub> = 32 $\Omega$		22		
V <sub>O</sub>	Output voltage <sup>(1)</sup> (Outputs in phase)	THD = 1%, V <sub>DD</sub> = 3.6 V, f = 1 kHz, R <sub>L</sub> = 100 $\Omega$		1.1		V <sub>RMS</sub>
A <sub>V</sub>	Closed-loop voltage gain (OUT / IN–)	GAIN = 0 V, (0 dB)	–0.95	–1.0	–1.05	V/V
		GAIN $\geq$ 1.3 V (6 dB)	–1.95	–2.0	–2.05	
$\Delta A_V$	Gain matching	Between Left and Right channels		1%		
R <sub>IN</sub>	Input impedance (per input pin)	GAIN = 0 V (0 dB)		19.8		k $\Omega$
		GAIN $\geq$ 1.3 V (6 dB)		13.2		
	Input impedance in shutdown (per input pin)	EN = 0 V		10		
V <sub>CM</sub>	Input common-mode voltage range		–0.5		1.5	V
	Output Impedance	EN = HI-Z $\geq$ 1.3 V, f = 10 kHz		40		k $\Omega$
		EN = HI-Z $\geq$ 1.3 V, f = 1 MHz		4.5		
		EN = HI-Z $\geq$ 1.3 V, f = 10 MHz		0.75		
		EN = 0 V (shutdown mode)		25		$\Omega$
	Input-to-output attenuation in shutdown	EN = 0 V		80		dB
AC PSRR	AC-power supply rejection ratio	200 mV <sub>pp</sub> ripple, f = 217 Hz	–80	–100		dB
		200 mV <sub>pp</sub> ripple, f = 10 kHz		–90		
THD+N	Total harmonic distortion plus noise <sup>(2)</sup>	P <sub>O</sub> = 20 mW, f = 1 kHz		0.02%		
		P <sub>O</sub> = 25 mW into 32 $\Omega$ , V <sub>DD</sub> = 5.5 V, f = 1 kHz		0.01%		
SNR	Signal-to-noise ratio	P <sub>O</sub> = 20 mW; GAIN = 0 V, (A <sub>V</sub> = 0 dB)		100		dB
E <sub>n</sub>	Noise output voltage	A-weighted		5.5		$\mu\text{V}_{\text{RMS}}$
f <sub>osc</sub>	Charge pump switching frequency		1200	1275	1350	kHz
t <sub>ON</sub>	Start-up time from shutdown			5		ms
	Crosstalk	P <sub>O</sub> = 20 mW, f = 1 kHz		–80		dB
	Thermal shutdown	Threshold		150		$^\circ\text{C}$
		Hysteresis		20		$^\circ\text{C}$

(1) Per output channel

(2) A-weighted

TYPICAL CHARACTERISTICS

$T_A = 25^\circ\text{C}$ ,  $V_{DD} = 3.6\text{ V}$ , Gain = 0 dB, EN = 3.6 V,  $C_{HPVDD} = C_{HPVSS} = 2.2\ \mu\text{F}$ ,  $C_{INPUT} = C_{FLYING} = 1\ \mu\text{F}$ , Outputs in Phase

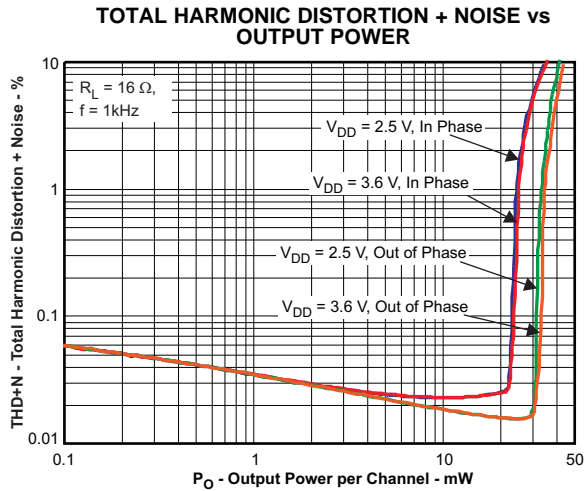

Figure 1.

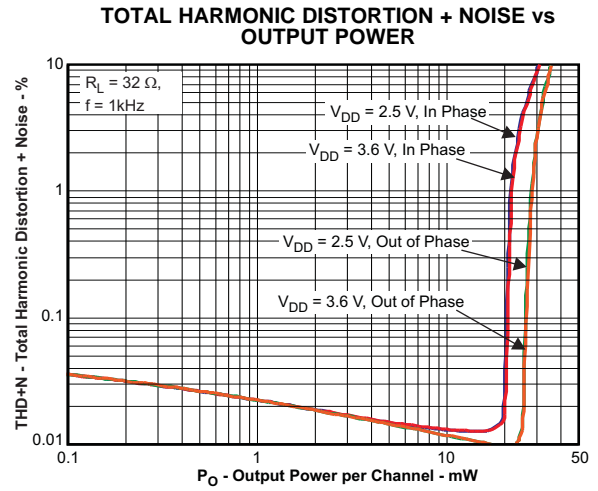

Figure 2.

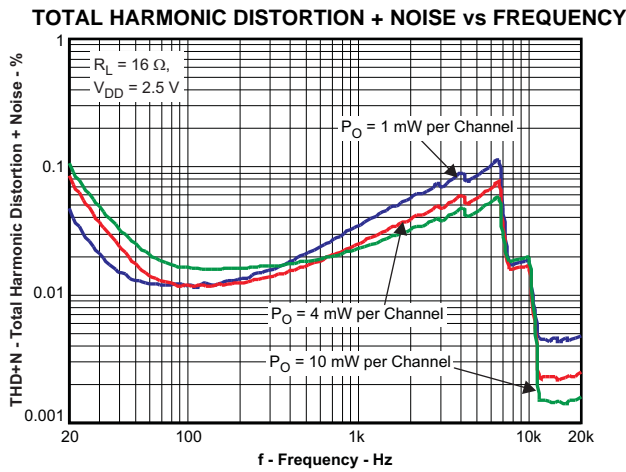

Figure 3.

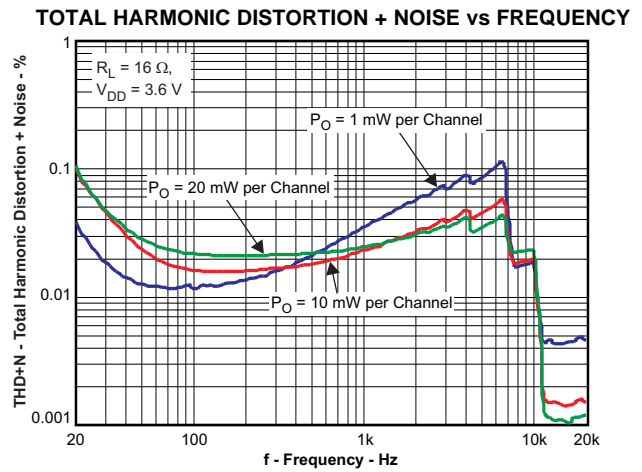

Figure 4.

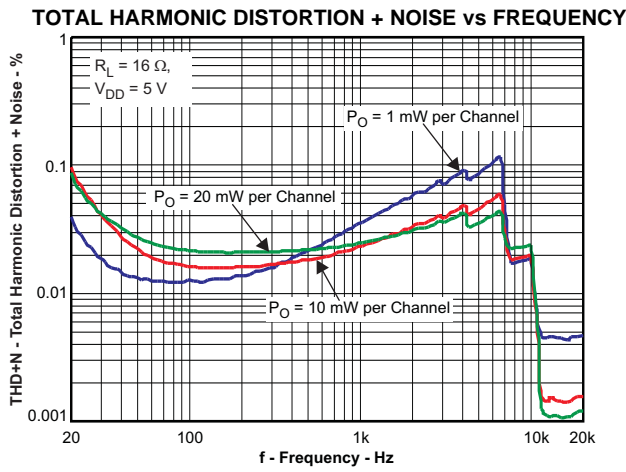

Figure 5.

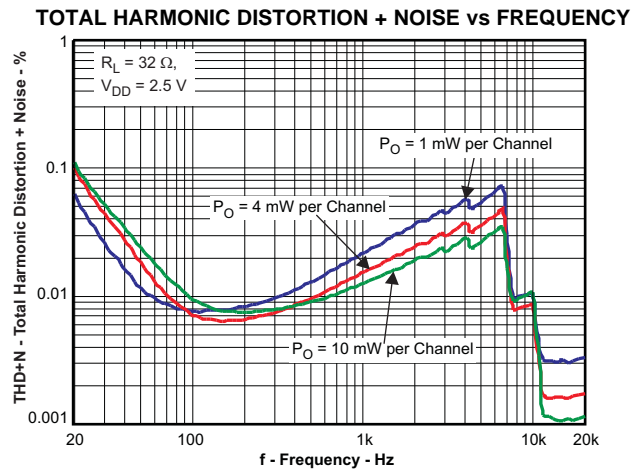

Figure 6.

TYPICAL CHARACTERISTICS (continued)

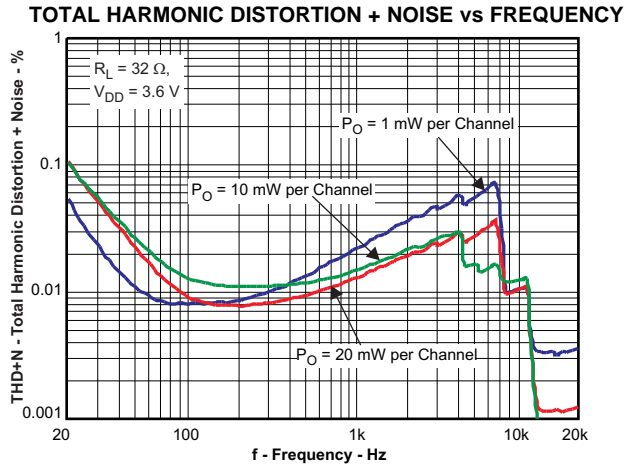

Figure 7.

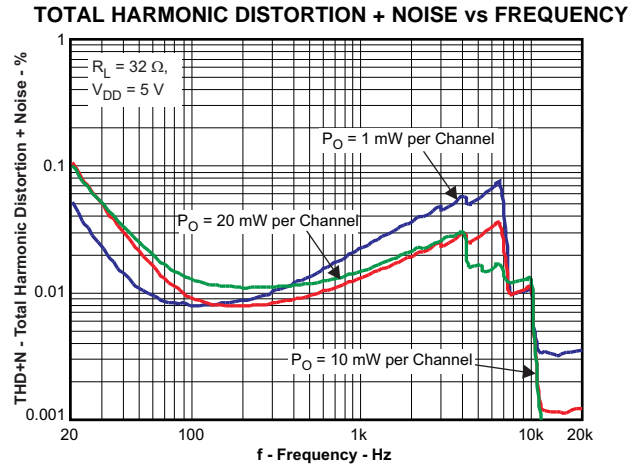

Figure 8.

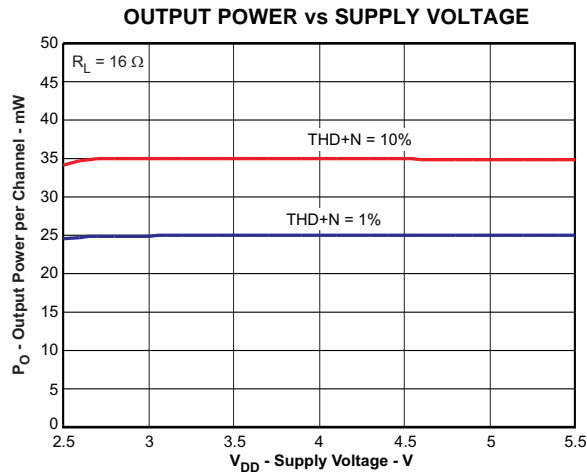

Figure 9.

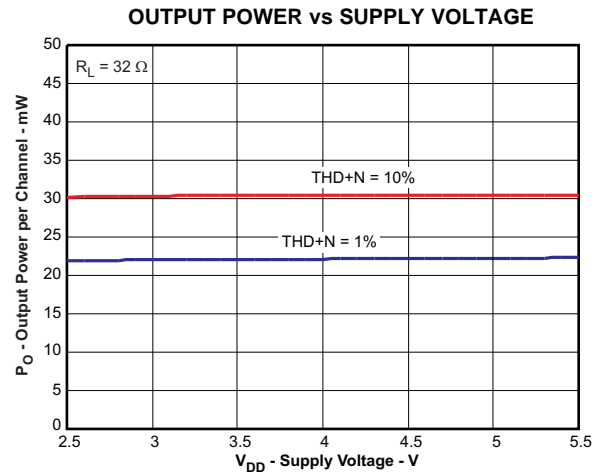

Figure 10.

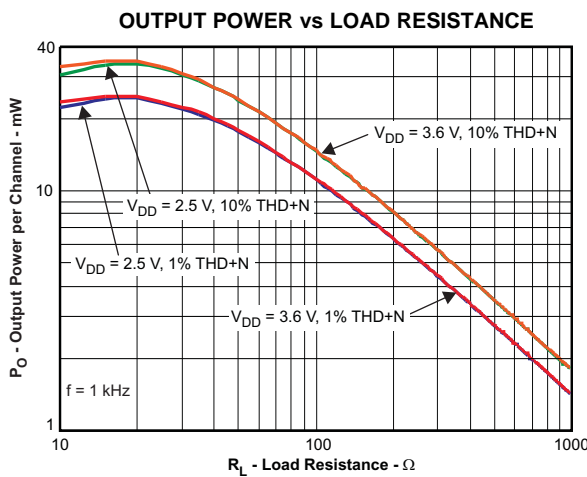

Figure 11.

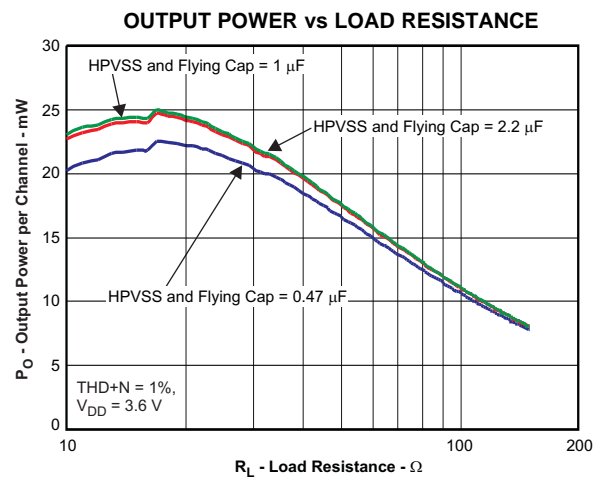

Figure 12.

TYPICAL CHARACTERISTICS (continued)

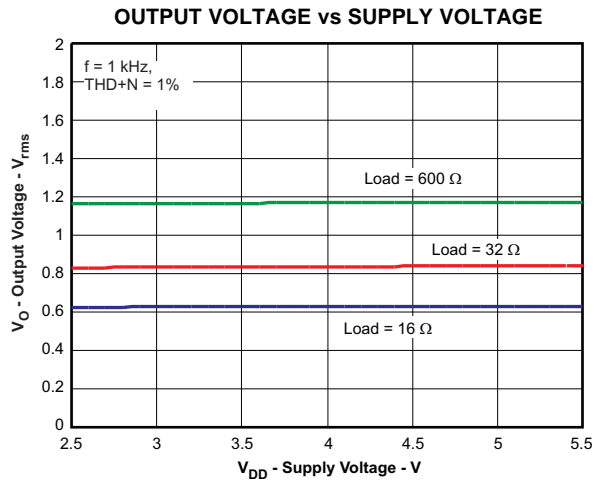

Figure 13.

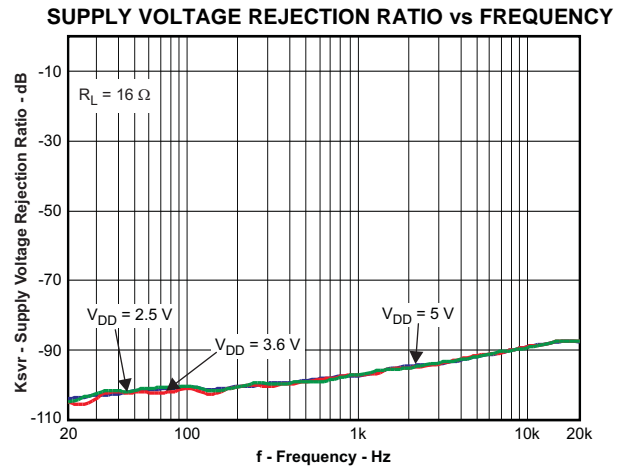

Figure 14.

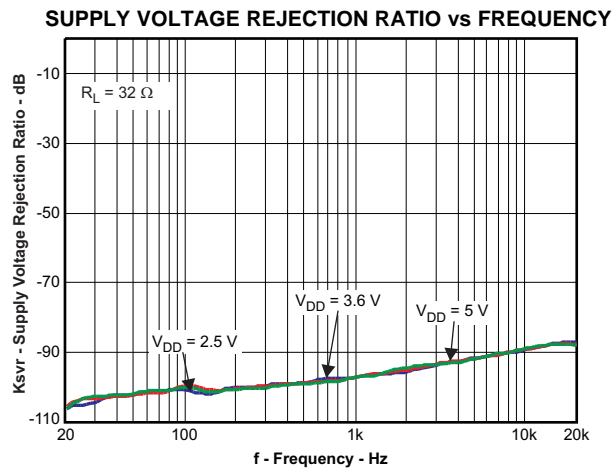

Figure 15.

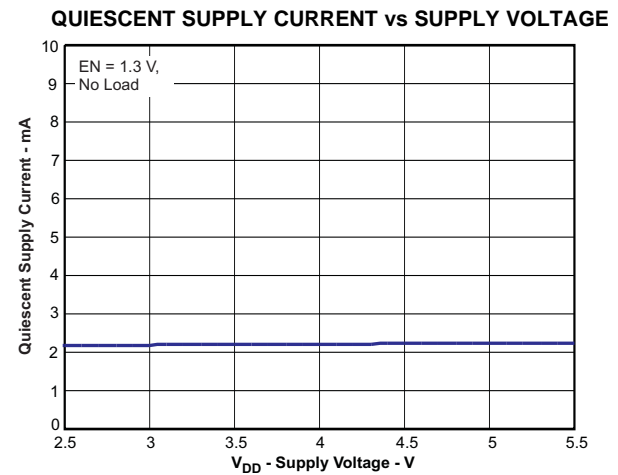

Figure 16.

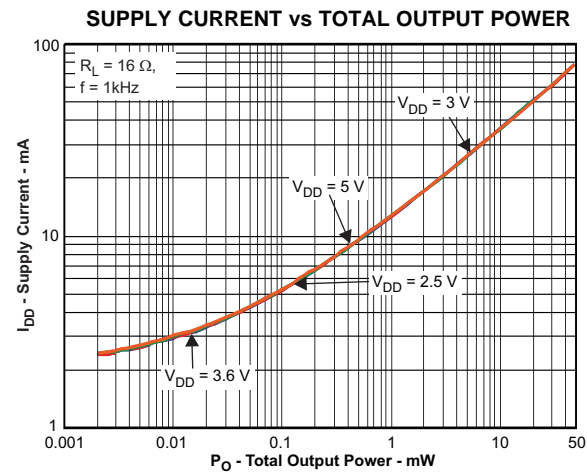

Figure 17.

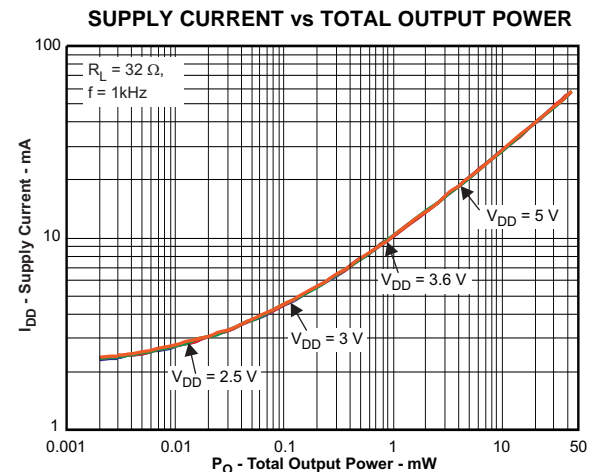

Figure 18.

TYPICAL CHARACTERISTICS (continued)

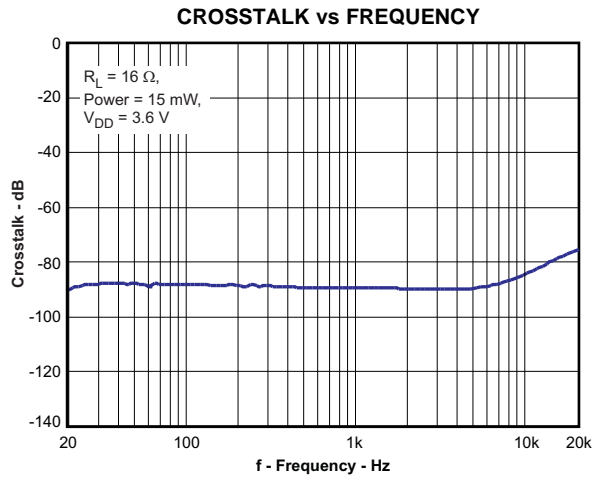

Figure 19.

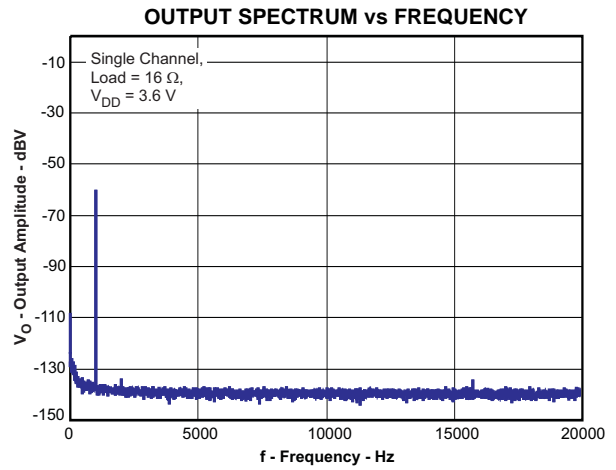

Figure 20.

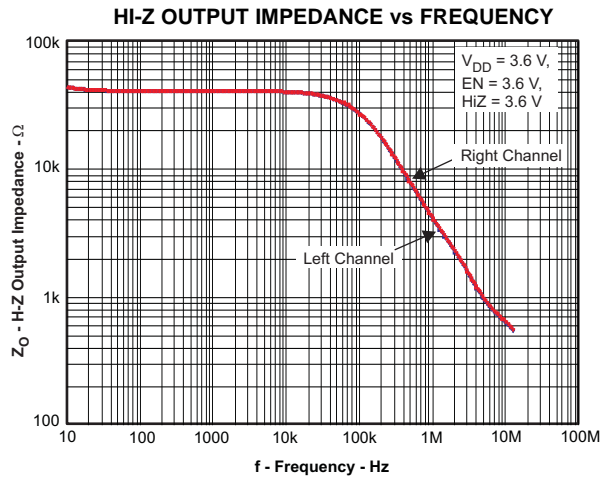

Figure 21.

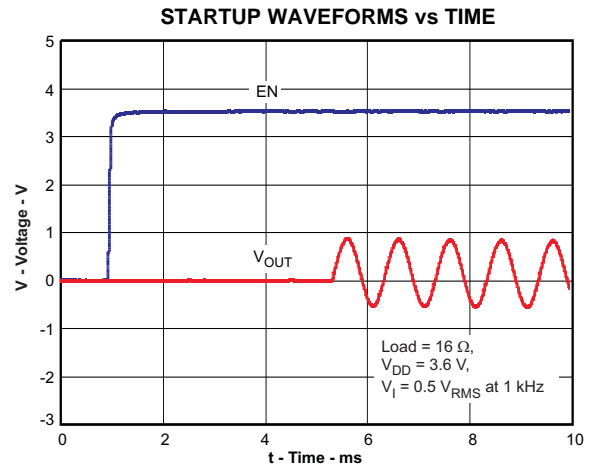

Figure 22.

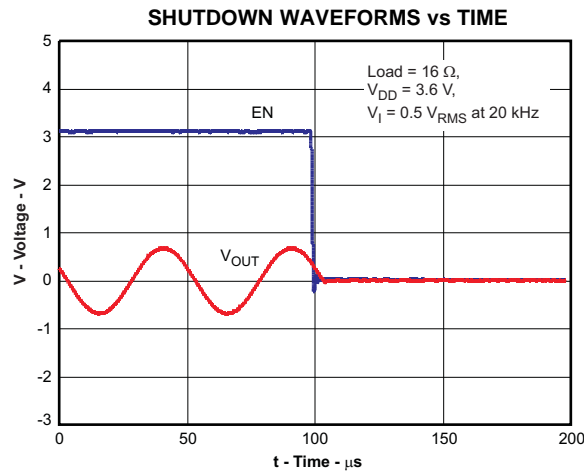

Figure 23.

APPLICATION INFORMATION

APPLICATION CIRCUIT

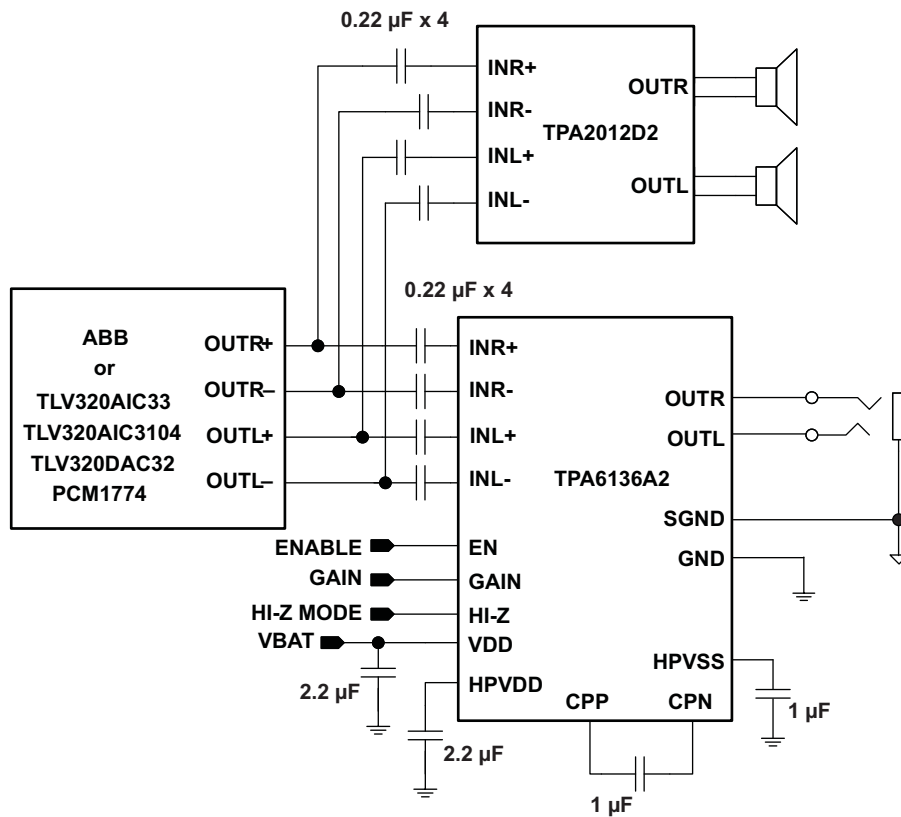

Figure 24. Typical Application Configuration with Differential Input Signals

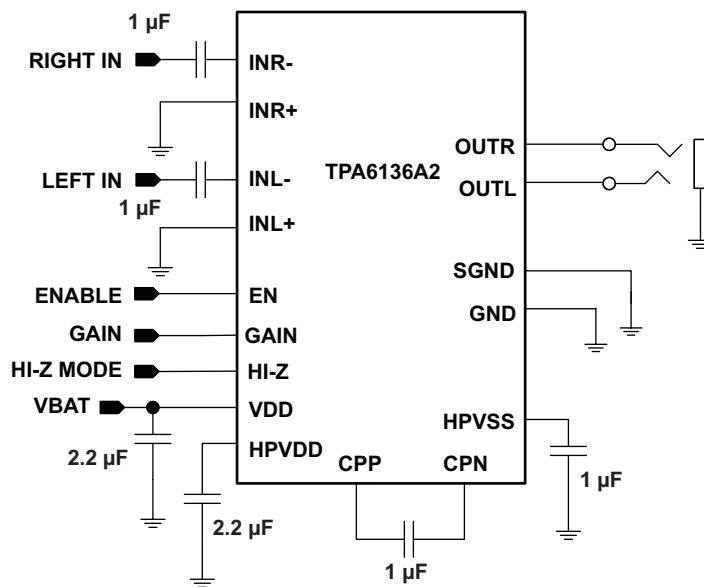

Figure 25. Typical Application Configuration with Single-Ended Input Signals

# TPA6136A2

SLOS621A–JULY 2009–REVISED AUGUST 2009

www.ti.com

## GAIN CONTROL

The TPA6136A2 has two gain settings which are controlled with the GAIN pin. The following table gives an overview of the gain function.

GAIN VOLTAGE	AMPLIFIER GAIN
$\leq 0.6\text{ V}$	0 dB
$\geq 1.3\text{ V}$	6 dB

**Table 1. Windows Vista™ Premium Mobile Mode Specifications**

Device Type	Requirement	Windows Premium Mobile Vista Specifications	TPA6136A2 Typical Performance
Analog Speaker Line Jack [ $R_L = 10\text{ k}\Omega$ , FS = 0.707 Vrms]	THD+N	$\leq -65\text{ dB FS}$ [20 Hz, 20 kHz]	-75 dB FS [20 Hz, 20 kHz]
	Dynamic Range with Signal Present	$\leq -80\text{ dB FS A-Weight}$	-100 dB FS A-Weight
	Line Output Crosstalk	$\leq -60\text{ dB}$ [20 Hz, 20 kHz]	-90 dB [20 Hz, 20 kHz]
Analog Headphone Out Jack [ $R_L = 32\Omega$ , FS = 0.300 Vrms]	THD+N	$\leq -45\text{ dB FS}$ [20 Hz, 20 kHz]	-65 dB FS [20 Hz, 20 kHz]
	Dynamic Range with Signal Present	$\leq -80\text{ dB FS A-Weight}$	-94 dB FS A-Weight
	Headphone Output Crosstalk	$\leq -60\text{ dB}$ [20 Hz, 20 kHz]	-90 dB [20 Hz, 20 kHz]

## HIGH OUTPUT IMPEDANCE

The TPA6136A2 has a HI-Z control pin that increases output impedance while muting the amplifier. Apply a voltage greater than 1.3 V to the HI-Z and EN pin to activate the HI-Z mode. This feature allows the headphone output jack to be shared for other functions besides audio. For example, sharing of a headphone jack between audio and video as shown in Figure 26. The TPA6136A2 output impedance is high enough to prevent attenuating the video signal.

Enable Voltage	HI-Z Voltage	Output Impedance	Maximum External Voltage Applied to the Output Pins	Comments
$\leq 0.6\text{ V}$	$\leq 0.6\text{ V}$	20 $\Omega$ – 30 $\Omega$	-0.3 V to 3.3 V <sup>(1)</sup>	Shutdown Mode
$\leq 0.6\text{ V}$	$\geq 1.3\text{ V}$	20 $\Omega$ – 30 $\Omega$		
$\geq 1.3\text{ V}$	$\leq 0.6\text{ V}$	$\leq 1\ \Omega$	–	Active Mode
$\geq 1.3\text{ V}$	$\geq 1.3\text{ V}$	40 k $\Omega$ @ 10 kHz	-1.8 V to 1.8 V	HI-Z Mode
		4.5 k $\Omega$ @ 1 MHz		
		750 $\Omega$ @ 10 MHz		

(1) If  $V_{DD}$  is < 3.3 V, then maximum allowed external voltage applied is  $V_{DD}$  in this mode

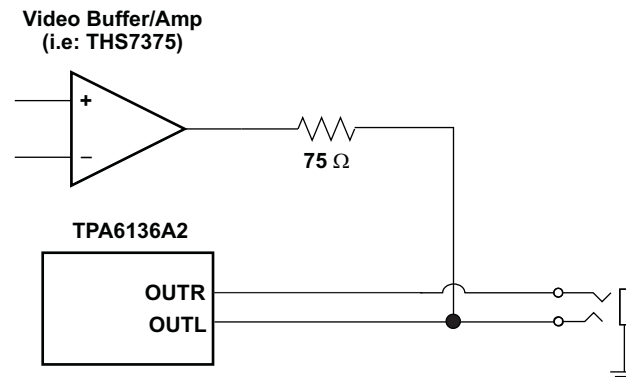

**Figure 26. Sharing One Connector Between Audio and Video Signals Example**

## GROUND SENSE FUNCTION

The ground sense pin, SGND, reduces ground-loop noise when the audio output jack is connected to a different ground reference than codec and amplifier ground. Always connect the SGND pin to the headphone jack. This reduces output offset voltage and eliminates turn-on pop. Figure 27 shows how to connect SGND when an FM radio antenna function is implemented on the headphone wire. The nH coil and capacitor separate the RF signal from the audio GND signal. In this case, SGND is used to eliminate the offset voltage that is generated from the audio signal current and the RF coil low-frequency impedance.

The voltage difference between SGND and AGND cannot be greater than  $\pm 300$  mV. The amplifier performance degrades if the voltage difference between SGND and AGND is greater than  $\pm 300$  mV.

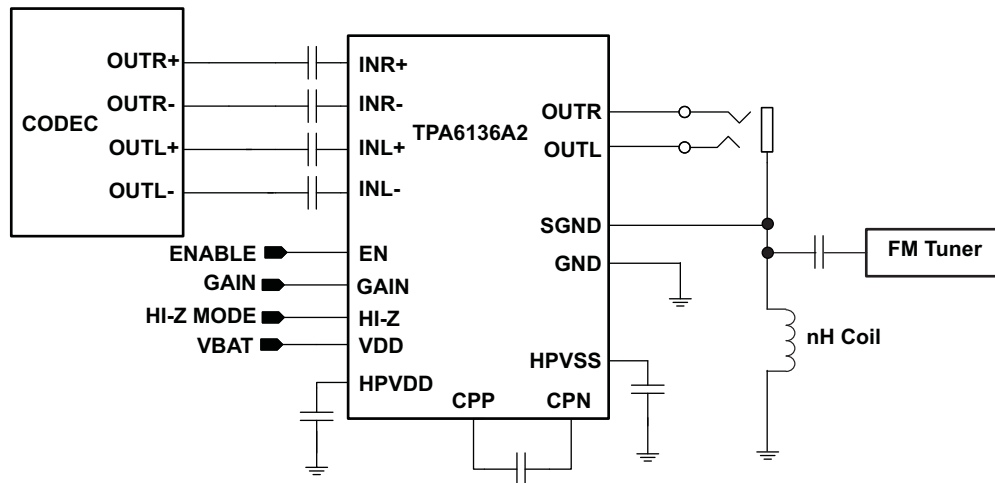

Figure 27. Typical Application Circuit Using Ground Sense Function

## HEADPHONE AMPLIFIERS

Single-supply headphone amplifiers typically require dc-blocking capacitors to remove dc bias from their output voltage. The top drawing in Figure 28 illustrates this connection. If dc bias is not removed, large dc current will flow through the headphones which wastes power, clips the output signal, and potentially damages the headphones.

These dc-blocking capacitors are often large in value and size. Headphone speakers have a typical resistance between  $16 \Omega$  and  $32 \Omega$ . This combination creates a high-pass filter with a cutoff frequency as shown in Equation 1, where  $R_L$  is the load impedance,  $C_O$  is the dc-block capacitor, and  $f_c$  is the cutoff frequency.

$$f_c = \frac{1}{2\pi R_L C_O} \quad (1)$$

For a given high-pass cutoff frequency and load impedance, the required dc-blocking capacitor is found as:

$$C_O = \frac{1}{2\pi f_c R_L} \quad (2)$$

Reducing  $f_c$  improves low frequency fidelity and requires a larger dc-blocking capacitor. To achieve a 20 Hz cutoff with  $16 \Omega$  headphones,  $C_O$  must be at least  $500 \mu\text{F}$ . Large capacitor values require large packages, consuming PCB area, increasing height, and increasing cost of assembly. During start-up or shutdown the dc-blocking capacitor has to be charged or discharged. This causes an audible pop on start-up and power-down. Large dc-blocking capacitors also reduce audio output signal fidelity.

Two different headphone amplifier architectures are available to eliminate the need for dc-blocking capacitors. The Capless amplifier architecture provides a reference voltage to the headphone connector shield pin as shown in the middle drawing of Figure 28. The audio output signals are centered around this reference voltage, which is typically half of the supply voltage to allow symmetrical output voltage swing.

When using a Capless amplifier do not connect the headphone jack shield to any ground reference or large currents will result. This makes Capless amplifiers ineffective for plugging non-headphone accessories into the headphone connector. Capless amplifiers are useful only with floating GND headphones.

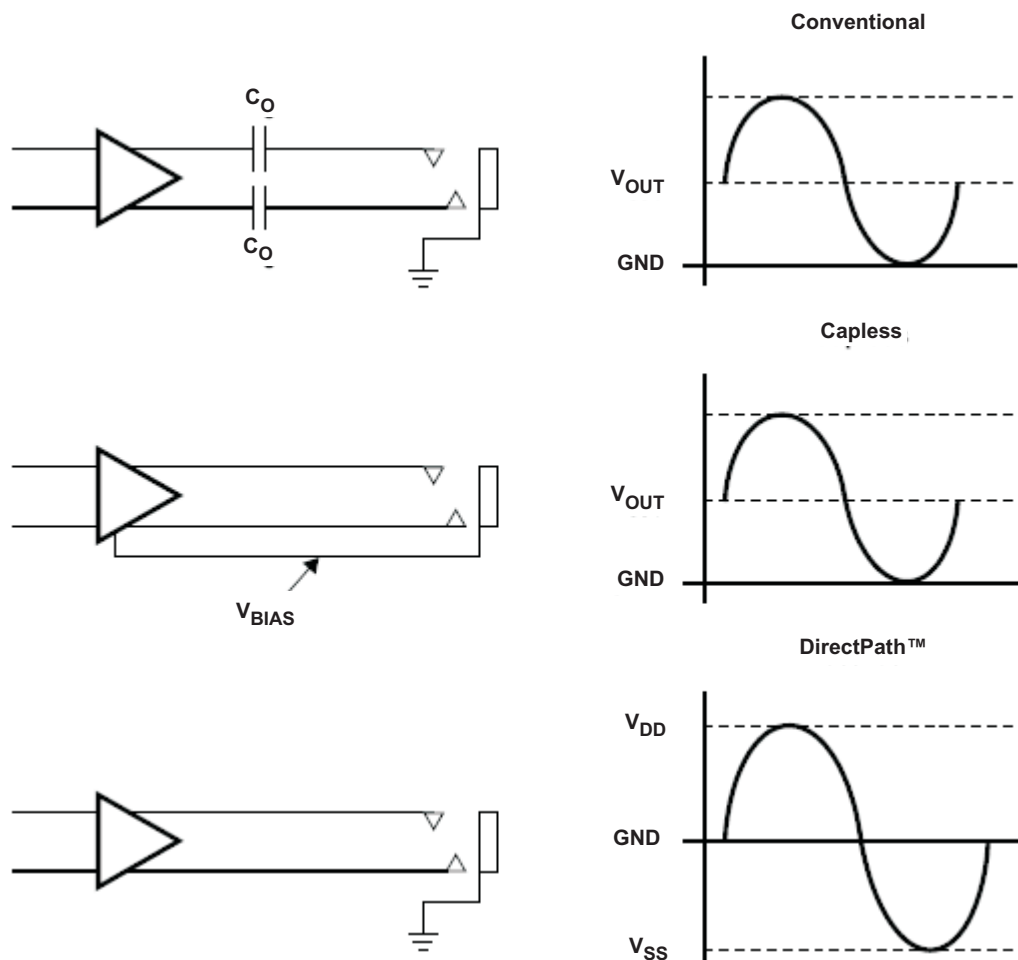

**Figure 28. Amplifier Applications**

The DirectPath™ amplifier architecture operates from a single supply voltage and uses an internal charge pump to generate a negative supply rail for the headphone amplifier. The output voltages are centered around 0 V and are capable of positive and negative voltage swings as shown in the bottom drawing of [Figure 28](#). DirectPath amplifiers require no output dc-blocking capacitors. The headphone connector shield pin connects to ground and will interface with headphones and non-headphone accessories. The TPA6136A2 is a DirectPath amplifier.

### ELIMINATING TURN-ON POP AND POWER SUPPLY SEQUENCING

The TPA6136A2 has excellent noise and turn-on / turn-off pop performance. It uses an integrated click-and-pop suppression circuit to allow fast start-up and shutdown without generating any voltage transients at the output pins. Typical start-up time from shutdown is 5 ms.

DirectPath technology keeps the output dc voltage at 0 V even when the amplifier is powered up. The DirectPath technology together with the active pop-and-click suppression circuit eliminates audible transients during start up and shutdown.

Use input coupling capacitors to ensure inaudible turn-on pop. Activate the TPA6136A2 after all audio sources have been activated and their output voltages have settled. On power-down, deactivate the TPA6136A2 before deactivating the audio input source. The EN pin controls device shutdown: Set to 0.6 V or lower to deactivate the TPA6136A2; set to 1.3 V or higher to activate.

## RF AND POWER SUPPLY NOISE IMMUNITY

The TPA6136A2 employs a new differential amplifier architecture to achieve high power supply noise rejection. Power supply noise is common in modern electronics. Although power supply noise frequencies are much higher than the 20 kHz audio band, signal modulation often falls in-band. This, in turn, modulates the supply voltage, allowing a coupling path into the audio amplifier. A common example is the 217 Hz GSM frame-rate buzz often heard from an active speaker when a cell phone is placed nearby during a phone call.

The TPA6136A2 has excellent rejection of power supply noise, preventing audio signal degradation.

## CONSTANT MAXIMUM OUTPUT POWER AND ACOUSTIC SHOCK PREVENTION

Typically the output power increases with increasing supply voltage on an unregulated headphone amplifier. The TPA6136A2 maintains a constant output power independent of the supply voltage. Thus the design for prevention of acoustic shock (hearing damage due to exposure to a loud sound) is simplified since the output power will remain constant, independent of the supply voltage. This feature allows maximizing the audio signal at the lowest supply voltage.

## INPUT COUPLING CAPACITORS

Input coupling capacitors block any dc bias from the audio source and ensure maximum dynamic range. Input coupling capacitors also minimize TPA6136A2 turn-on pop to an inaudible level.

The input capacitors are in series with TPA6136A2 internal input resistors, creating a high-pass filter. [Equation 3](#) calculates the high-pass filter corner frequency. The input impedance,  $R_{IN}$ , is dependent on device gain. Larger input capacitors decrease the corner frequency. See the Operating Characteristics table for input impedance values.

$$f_C = \frac{1}{2\pi R_{IN} C_{IN}} \quad (3)$$

For a given high-pass cutoff frequency, the minimum input coupling capacitor is found as:

$$C_{IN} = \frac{1}{2\pi f_C R_{IN}} \quad (4)$$

Example: Design for a 20 Hz corner frequency with a TPA6136A2 gain of +6 dB. The Operating Characteristics table gives  $R_{IN}$  as 13.2 k $\Omega$ . [Equation 4](#) shows the input coupling capacitors must be at least 0.6  $\mu$ F to achieve a 20 Hz high-pass corner frequency. Choose a 0.68  $\mu$ F standard value capacitor for each TPA6136A2 input (X5R material or better is required for best performance).

Input capacitors can be removed provided the TPA6136A2 inputs are driven differentially with less than  $\pm 1 V_{RMS}$  and the common-mode voltage is within the input common-mode range of the amplifier. Without input capacitors turn-on pop performance may be degraded and should be evaluated in the system.

## CHARGE PUMP FLYING CAPACITOR AND HPVSS CAPACITOR

The TPA6136A2 uses a built-in charge pump to generate a negative voltage supply for the headphone amplifiers. The charge pump flying capacitor connects between CPP and CPN. It transfers charge to generate the negative supply voltage. The HPVSS capacitor must be at least equal in value to the flying capacitor to allow maximum charge transfer. Use low equivalent-series-resistance (ESR) ceramic capacitors (X5R material or better is required for best performance) to maximize charge pump efficiency. Typical values are 1  $\mu$ F to 2.2  $\mu$ F for the HPVSS and flying capacitors. Although values down to 0.47  $\mu$ F can be used, total harmonic distortion (THD) will increase.

## OPERATION WITH DACs AND CODECs AND INPUT RF NOISE REJECTION

When using amplifiers with CODECs and DACs, sometimes there is an increase in the output noise floor from the audio amplifier. This occurs when the output out-of-band noise of the CODEC/DAC folds back into the audio frequency due to the limited gain bandwidth product of the audio amplifier. Single-ended RF noise can also fold back into the audio band thus degrading the audio signal even further.

## TPA6136A2

SLOS621A–JULY 2009–REVISED AUGUST 2009

www.ti.com

The TPA6136A2 has a built-in low-pass filter to reduce CODEC/DAC out-of-band noise and RF noise, that could fold back into the audio frequency.

### POWER SUPPLY AND HPVDD DECOUPLING CAPACITORS AND CONNECTIONS

The TPA6136A2 DirectPath headphone amplifier requires adequate power supply decoupling to ensure that output noise and total harmonic distortion (THD) remain low. Use good low equivalent-series-resistance (ESR) ceramic capacitors (X5R material or better is required for best performance). Place a 2.2  $\mu\text{F}$  capacitor within 5 mm of the VDD pin. Reducing the distance between the decoupling capacitor and VDD minimizes parasitic inductance and resistance, improving TPA6136A2 supply rejection performance. Use 0402 or smaller size capacitors if possible. Ensure that the ground connection of each of the capacitors has a minimum length return path to the device. Failure to properly decouple the TPA6136A2 may degrade audio or EMC performance.

For additional supply rejection, connect an additional 10  $\mu\text{F}$  or higher value capacitor between VDD and ground. This will help filter lower frequency power supply noise. The high power supply rejection ratio (PSRR) of the TPA6136A2 makes the 10  $\mu\text{F}$  capacitor unnecessary in most applications.

Connect a 2.2  $\mu\text{F}$  capacitor between HPVDD and ground. This ensures the amplifier internal bias supply remains stable and maximizes headphone amplifier performance.

#### WARNING:

**DO NOT connect HPVDD directly to VDD or an external supply voltage. The voltage at HPVDD is generated internally. Connecting HPVDD to an external voltage can damage the device.**

### PACKAGE INFORMATION

#### Package Dimensions

The package dimensions for this YFF package are shown in the table below. See the package drawing at the end of this data sheet for more details.

**Table 2. YFF Package Dimensions**

Packaged Devices	D	E
TPA6136A2YFF	Min = 1530 $\mu\text{m}$ Max = 1590 $\mu\text{m}$	Min = 1530 $\mu\text{m}$ Max = 1590 $\mu\text{m}$

### LAYOUT RECOMMENDATIONS

#### GND CONNECTIONS

The SGND pin is an input reference and must be connected to the headphone ground connector pin. This ensures no turn-on pop and minimizes output offset voltage. Do not connect more than  $\pm 0.3$  V to SGND.

GND is a power ground. Connect supply decoupling capacitors for VDD, HPVDD, and HPVSS to GND.

#### BOARD LAYOUT

In making the pad size for the WCSP balls, it is recommended that the layout use non-solder-mask defined (NSMD) land. With this method, the solder mask opening is made larger than the desired land area, and the opening size is defined by the copper pad width. [Figure 29](#) and [Table 3](#) shows the appropriate diameters for a WCSP layout.

For improved RF immunity it is recommended that all signal traces are routed in the middle layers of the multi-layer PCB. The top and bottom layers are used for the supply voltage plane and the GND plane.

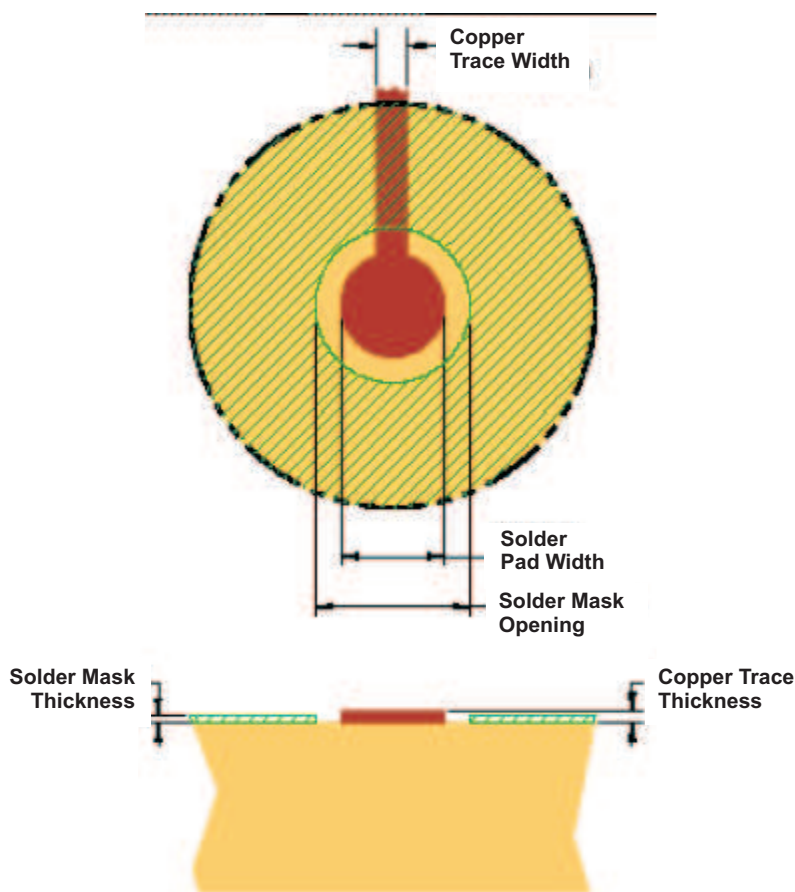

Figure 29. Land Pattern Dimensions

Table 3. Land Pattern Dimensions<sup>(1) (2) (3) (4)</sup>

SOLDER PAD DEFINITIONS	COPPER PAD	SOLDER MASK <sup>(5)</sup> OPENING	COPPER THICKNESS	STENCIL <sup>(6) (7)</sup> OPENING	STENCIL THICKNESS
Non-solder-mask defined (NSMD)	230 $\mu\text{m}$ (+0.0, -25 $\mu\text{m}$ )	310 $\mu\text{m}$ (+0.0, -25 $\mu\text{m}$ )	1 oz max (32 $\mu\text{m}$ )	275 $\mu\text{m}$ x 275 $\mu\text{m}$ Sq. (rounded corners)	100 $\mu\text{m}$ thick

- (1) Circuit traces from NSMD defined PWB lands should be 75  $\mu\text{m}$  to 100  $\mu\text{m}$  wide in the exposed area inside the solder mask opening. Wider trace widths reduce device stand off and impact reliability.
- (2) Best reliability results are achieved when the PWB laminate glass transition temperature is above the operating the range of the intended application
- (3) Recommend solder paste is Type 3 or Type 4.
- (4) For a PWB using a Ni/Au surface finish, the gold thickness should be less 0,5 mm to avoid a reduction in thermal fatigue performance.
- (5) Solder mask thickness should be less than 20  $\mu\text{m}$  on top of the copper circuit pattern
- (6) Best solder stencil performance is achieved using laser cut stencils with electro polishing. Use of chemically etched stencils results in inferior solder paste volume control.
- (7) Trace routing away from WCSP device should be balanced in X and Y directions to avoid unintentional component movement due to solder wetting forces.

## TRACE WIDTH

Recommended trace width at the solder balls is 75  $\mu\text{m}$  to 100  $\mu\text{m}$  to prevent solder wicking onto wider PCB traces. For high current pins (VDD, HPVDD, HPVSS, CPP, CPN, OUTL, and OUTR) of the TPA6136A2, use 100  $\mu\text{m}$  trace widths at the solder balls and at least 500  $\mu\text{m}$  PCB traces to ensure proper performance and output power for the device. For the remaining signals of the TPA6136A2, use 75  $\mu\text{m}$  to 100  $\mu\text{m}$  trace widths at the solder balls. The audio input pins (INL-, INL+, INR- and INR+) must run side-by-side to maximize common-mode noise cancellation.

**PACKAGING INFORMATION**

Orderable Device	Status (1)	Package Type	Package Drawing	Pins	Package Qty	Eco Plan (2)	Lead/Ball Finish (6)	MSL Peak Temp (3)	Op Temp (°C)	Device Marking (4/5)	Samples
TPA6136A2YFFR	ACTIVE	DSBGA	YFF	16	3000	Green (RoHS & no Sb/Br)	SNAGCU	Level-1-260C-UNLIM	-40 to 85	AOW1	<a href="#">Samples</a>
TPA6136A2YFFT	ACTIVE	DSBGA	YFF	16	250	Green (RoHS & no Sb/Br)	SNAGCU	Level-1-260C-UNLIM	-40 to 85	AOW1	<a href="#">Samples</a>

(1) The marketing status values are defined as follows:

**ACTIVE:** Product device recommended for new designs.

**LIFEBUY:** TI has announced that the device will be discontinued, and a lifetime-buy period is in effect.

**NRND:** Not recommended for new designs. Device is in production to support existing customers, but TI does not recommend using this part in a new design.

**PREVIEW:** Device has been announced but is not in production. Samples may or may not be available.

**OBSELETE:** TI has discontinued the production of the device.

(2) Eco Plan - The planned eco-friendly classification: Pb-Free (RoHS), Pb-Free (RoHS Exempt), or Green (RoHS & no Sb/Br) - please check <http://www.ti.com/productcontent> for the latest availability information and additional product content details.

**TBD:** The Pb-Free/Green conversion plan has not been defined.

**Pb-Free (RoHS):** TI's terms "Lead-Free" or "Pb-Free" mean semiconductor products that are compatible with the current RoHS requirements for all 6 substances, including the requirement that lead not exceed 0.1% by weight in homogeneous materials. Where designed to be soldered at high temperatures, TI Pb-Free products are suitable for use in specified lead-free processes.

**Pb-Free (RoHS Exempt):** This component has a RoHS exemption for either 1) lead-based flip-chip solder bumps used between the die and package, or 2) lead-based die adhesive used between the die and leadframe. The component is otherwise considered Pb-Free (RoHS compatible) as defined above.

**Green (RoHS & no Sb/Br):** TI defines "Green" to mean Pb-Free (RoHS compatible), and free of Bromine (Br) and Antimony (Sb) based flame retardants (Br or Sb do not exceed 0.1% by weight in homogeneous material)

(3) MSL, Peak Temp. - The Moisture Sensitivity Level rating according to the JEDEC industry standard classifications, and peak solder temperature.

(4) There may be additional marking, which relates to the logo, the lot trace code information, or the environmental category on the device.

(5) Multiple Device Markings will be inside parentheses. Only one Device Marking contained in parentheses and separated by a "~" will appear on a device. If a line is indented then it is a continuation of the previous line and the two combined represent the entire Device Marking for that device.

(6) Lead/Ball Finish - Orderable Devices may have multiple material finish options. Finish options are separated by a vertical ruled line. Lead/Ball Finish values may wrap to two lines if the finish value exceeds the maximum column width.

**Important Information and Disclaimer:** The information provided on this page represents TI's knowledge and belief as of the date that it is provided. TI bases its knowledge and belief on information provided by third parties, and makes no representation or warranty as to the accuracy of such information. Efforts are underway to better integrate information from third parties. TI has taken and continues to take reasonable steps to provide representative and accurate information but may not have conducted destructive testing or chemical analysis on incoming materials and chemicals. TI and TI suppliers consider certain information to be proprietary, and thus CAS numbers and other limited information may not be available for release.

In no event shall TI's liability arising out of such information exceed the total purchase price of the TI part(s) at issue in this document sold by TI to Customer on an annual basis.

**TAPE AND REEL INFORMATION**

**QUADRANT ASSIGNMENTS FOR PIN 1 ORIENTATION IN TAPE**

\*All dimensions are nominal

Device	Package Type	Package Drawing	Pins	SPQ	Reel Diameter (mm)	Reel Width W1 (mm)	A0 (mm)	B0 (mm)	K0 (mm)	P1 (mm)	W (mm)	Pin1 Quadrant
TPA6136A2YFFR	DSBGA	YFF	16	3000	180.0	8.4	1.65	1.65	0.81	4.0	8.0	Q1
TPA6136A2YFFT	DSBGA	YFF	16	250	180.0	8.4	1.65	1.65	0.81	4.0	8.0	Q1

**TAPE AND REEL BOX DIMENSIONS**



\*All dimensions are nominal

Device	Package Type	Package Drawing	Pins	SPQ	Length (mm)	Width (mm)	Height (mm)
TPA6136A2YFFR	DSBGA	YFF	16	3000	182.0	182.0	20.0
TPA6136A2YFFT	DSBGA	YFF	16	250	182.0	182.0	20.0

# MECHANICAL DATA

YFF (S-XBGA-N16)

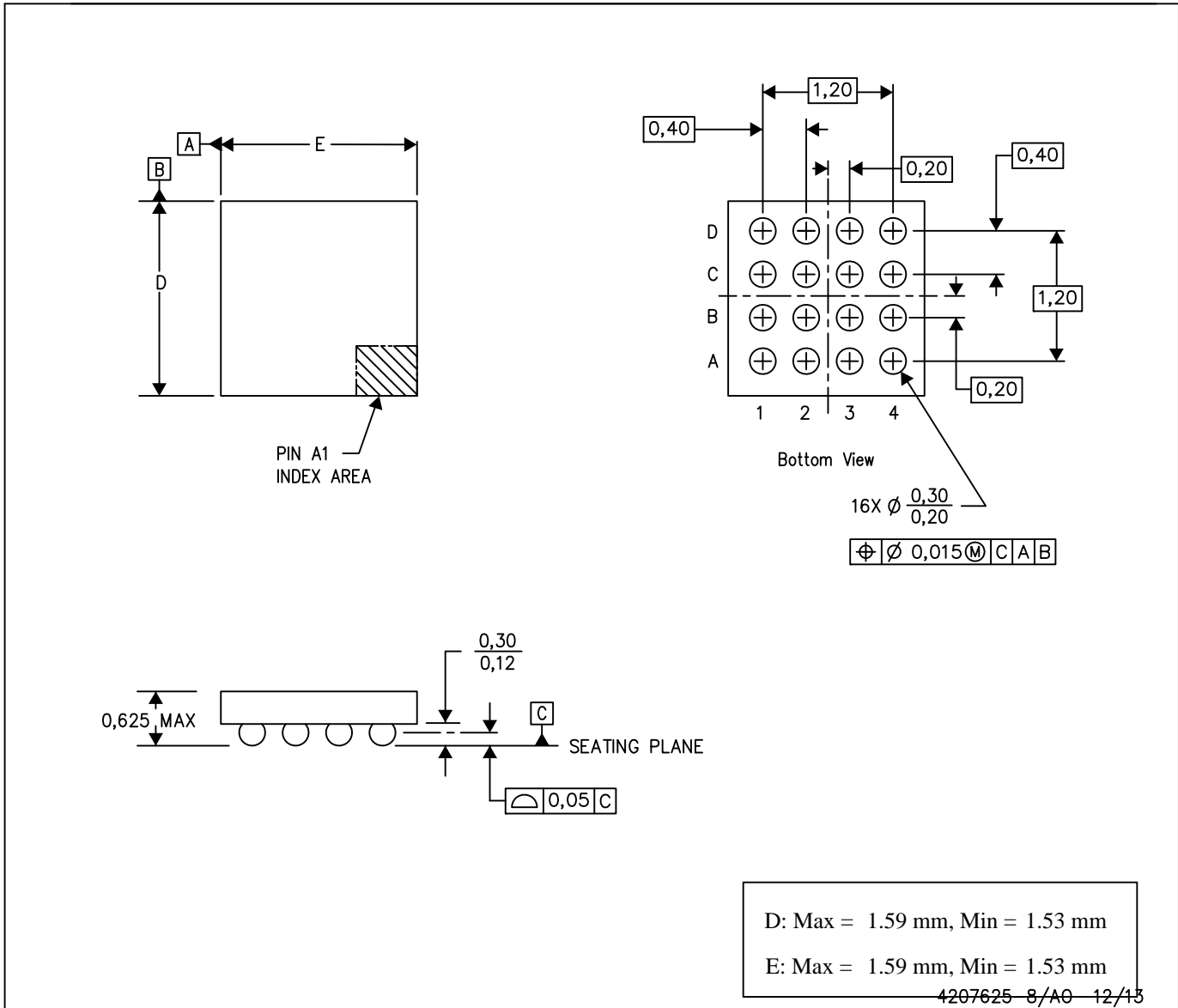
DIE-SIZE BALL GRID ARRAY



- NOTES: A. All linear dimensions are in millimeters. Dimensioning and tolerancing per ASME Y14.5M-1994.  
B. This drawing is subject to change without notice.  
C. NanoFree™ package configuration.

NanoFree is a trademark of Texas Instruments.

## IMPORTANT NOTICE

Texas Instruments Incorporated and its subsidiaries (TI) reserve the right to make corrections, enhancements, improvements and other changes to its semiconductor products and services per JESD46, latest issue, and to discontinue any product or service per JESD48, latest issue. Buyers should obtain the latest relevant information before placing orders and should verify that such information is current and complete. All semiconductor products (also referred to herein as "components") are sold subject to TI's terms and conditions of sale supplied at the time of order acknowledgment.

TI warrants performance of its components to the specifications applicable at the time of sale, in accordance with the warranty in TI's terms and conditions of sale of semiconductor products. Testing and other quality control techniques are used to the extent TI deems necessary to support this warranty. Except where mandated by applicable law, testing of all parameters of each component is not necessarily performed.

TI assumes no liability for applications assistance or the design of Buyers' products. Buyers are responsible for their products and applications using TI components. To minimize the risks associated with Buyers' products and applications, Buyers should provide adequate design and operating safeguards.

TI does not warrant or represent that any license, either express or implied, is granted under any patent right, copyright, mask work right, or other intellectual property right relating to any combination, machine, or process in which TI components or services are used. Information published by TI regarding third-party products or services does not constitute a license to use such products or services or a warranty or endorsement thereof. Use of such information may require a license from a third party under the patents or other intellectual property of the third party, or a license from TI under the patents or other intellectual property of TI.

Reproduction of significant portions of TI information in TI data books or data sheets is permissible only if reproduction is without alteration and is accompanied by all associated warranties, conditions, limitations, and notices. TI is not responsible or liable for such altered documentation. Information of third parties may be subject to additional restrictions.

Resale of TI components or services with statements different from or beyond the parameters stated by TI for that component or service voids all express and any implied warranties for the associated TI component or service and is an unfair and deceptive business practice. TI is not responsible or liable for any such statements.

Buyer acknowledges and agrees that it is solely responsible for compliance with all legal, regulatory and safety-related requirements concerning its products, and any use of TI components in its applications, notwithstanding any applications-related information or support that may be provided by TI. Buyer represents and agrees that it has all the necessary expertise to create and implement safeguards which anticipate dangerous consequences of failures, monitor failures and their consequences, lessen the likelihood of failures that might cause harm and take appropriate remedial actions. Buyer will fully indemnify TI and its representatives against any damages arising out of the use of any TI components in safety-critical applications.

In some cases, TI components may be promoted specifically to facilitate safety-related applications. With such components, TI's goal is to help enable customers to design and create their own end-product solutions that meet applicable functional safety standards and requirements. Nonetheless, such components are subject to these terms.

No TI components are authorized for use in FDA Class III (or similar life-critical medical equipment) unless authorized officers of the parties have executed a special agreement specifically governing such use.

Only those TI components which TI has specifically designated as military grade or "enhanced plastic" are designed and intended for use in military/aerospace applications or environments. Buyer acknowledges and agrees that any military or aerospace use of TI components which have **not** been so designated is solely at the Buyer's risk, and that Buyer is solely responsible for compliance with all legal and regulatory requirements in connection with such use.

TI has specifically designated certain components as meeting ISO/TS16949 requirements, mainly for automotive use. In any case of use of non-designated products, TI will not be responsible for any failure to meet ISO/TS16949.

### Products

Audio	<a href="http://www.ti.com/audio">www.ti.com/audio</a>
Amplifiers	<a href="http://amplifier.ti.com">amplifier.ti.com</a>
Data Converters	<a href="http://dataconverter.ti.com">dataconverter.ti.com</a>
DLP® Products	<a href="http://www.dlp.com">www.dlp.com</a>
DSP	<a href="http://dsp.ti.com">dsp.ti.com</a>
Clocks and Timers	<a href="http://www.ti.com/clocks">www.ti.com/clocks</a>
Interface	<a href="http://interface.ti.com">interface.ti.com</a>
Logic	<a href="http://logic.ti.com">logic.ti.com</a>
Power Mgmt	<a href="http://power.ti.com">power.ti.com</a>
Microcontrollers	<a href="http://microcontroller.ti.com">microcontroller.ti.com</a>
RFID	<a href="http://www.ti-rfid.com">www.ti-rfid.com</a>
OMAP Applications Processors	<a href="http://www.ti.com/omap">www.ti.com/omap</a>
Wireless Connectivity	<a href="http://www.ti.com/wirelessconnectivity">www.ti.com/wirelessconnectivity</a>

### Applications

Automotive and Transportation	<a href="http://www.ti.com/automotive">www.ti.com/automotive</a>
Communications and Telecom	<a href="http://www.ti.com/communications">www.ti.com/communications</a>
Computers and Peripherals	<a href="http://www.ti.com/computers">www.ti.com/computers</a>
Consumer Electronics	<a href="http://www.ti.com/consumer-apps">www.ti.com/consumer-apps</a>
Energy and Lighting	<a href="http://www.ti.com/energy">www.ti.com/energy</a>
Industrial	<a href="http://www.ti.com/industrial">www.ti.com/industrial</a>
Medical	<a href="http://www.ti.com/medical">www.ti.com/medical</a>
Security	<a href="http://www.ti.com/security">www.ti.com/security</a>
Space, Avionics and Defense	<a href="http://www.ti.com/space-avionics-defense">www.ti.com/space-avionics-defense</a>
Video and Imaging	<a href="http://www.ti.com/video">www.ti.com/video</a>

### TI E2E Community

[e2e.ti.com](http://e2e.ti.com)