

DirectPath™ 25-mW Headphone Amplifier With Programmable-Fixed Gain

Check for Samples: [TPA6139A2](#)

FEATURES

- **DirectPath™**
 - Eliminates Pop/Clicks
 - Eliminates Output DC-Blocking Capacitors
 - 3 V to 3.6 V Supply voltage
- **Low Noise and THD**
 - SNR > 105 dB at –1x Gain
 - Typical $V_n < 15 \mu\text{Vms}$ 20-20kHz at –1x Gain
 - THD+N < 0.003% at 10k Ω Load and –1x Gain
- **25 mW into 600 Ω Load**
- **2 Vrms Output Voltage into 5k Ω Load**
- **Single Ended Input and Output**
- **Programmable Gain Select Reduces Component Count**
 - 13x Gain Values
- **Active Mute With More Than 80dB Attenuation**
- **Short Circuit and Thermal Protection**
- **$\pm 8\text{kV}$ HBM ESD Protected Outputs**

APPLICATIONS

- PDP / LCD TV
- Blu-ray Disc™, DVD Players
- Mini/Micro Combo Systems
- Soundcards

DESCRIPTION

The TPA6139A2PW is a 25mW Pop-Free stereo Head Phone driver designed to reduce component count, board space and cost. It is ideal for single supply electronics where size and cost are critical design parameters.

The TPA6139A2 does not require a power supply greater than 3.3V to generate its 25mW, nor does it require a split rail power supply.

Designed using TI's patented DIRECTPATH™ technology which integrates a charge pump to generate a negative supply rail that provides a clean, pop-free ground biased output. The TPA6139A2 is capable of driving 25mW into 32 Ω and 2Vrms into a 600 Ω load. DIRECTPATH also allows the removal of the costly output DC-blocking capacitors.

The device has fixed gain single ended inputs with a gain select pin. Using a single resistor on this pin, the designer can choose from 13 internal programmable gain settings to match the line driver with the Codec output level. It also reduces the component count and board space.

Headphone outputs have $\pm 8\text{kV}$ HBM ESD protection enabling a simple ESD protection circuit. The TPA6139A2 has built-in active mute control with more than 80dB attenuation for pop-free mute on/off control.

The TPA6139A2 is available in a 14-pin TSSOP and a 16-pin QFN. For a pin compatible 2vrms line driver see DRV612.

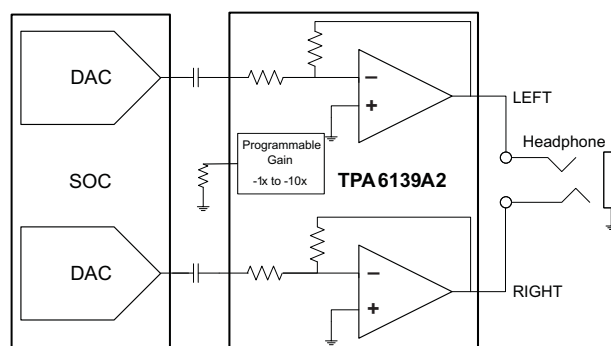

Please be aware that an important notice concerning availability, standard warranty, and use in critical applications of Texas Instruments semiconductor products and disclaimers thereto appears at the end of this data sheet.

DirectPath, DIRECTPATH are trademarks of Texas Instruments.

Blu-ray Disc is a trademark of Blu-ray Disc Association.

UNLESS OTHERWISE NOTED this document contains PRODUCTION DATA information current as of publication date. Products conform to specifications per the terms of Texas Instruments standard warranty. Production processing does not necessarily include testing of all parameters.

TPA6139A2

SLOS700B – JANUARY 2011 – REVISED JUNE 2012

www.ti.com



These devices have limited built-in ESD protection. The leads should be shorted together or the device placed in conductive foam during storage or handling to prevent electrostatic damage to the MOS gates.

GENERAL INFORMATION

PIN ASSIGNMENT

The TPA6139A2 is available in the:

- 14-pin TSSOP package (PW) or
- 16-pin QFN package (RGT)

PW PACKAGE
TSSOP
(TOP VIEW)

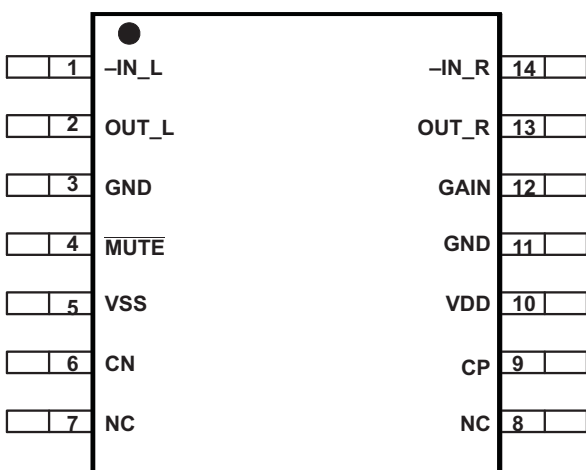

RGT PACKAGE
QFN
(TOP VIEW)

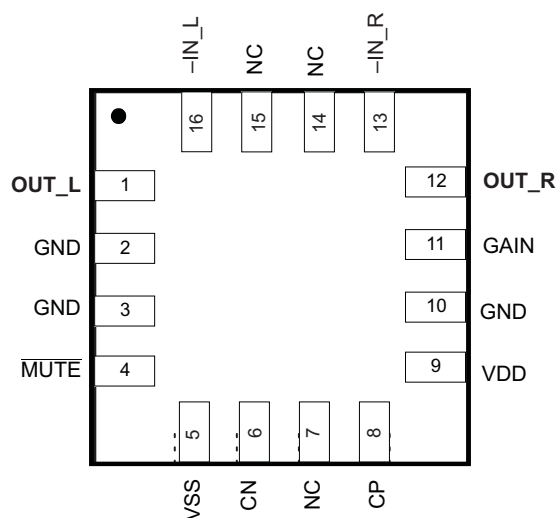

PIN FUNCTIONS

NAME	PIN		FUNCTION ⁽¹⁾	DESCRIPTION
	PW NO.	RGT NO.		
-IN_L	1	16	I	Negative input, left channel
OUT_L	2	1	O	Output, left channel
GND	3, 11	2, 3, 10	P	Ground
$\overline{\text{MUTE}}$	4	4	I	MUTE, active low
VSS	5	5	O	Charge Pump negative supply voltage
CN	6	6	I/O	Charge Pump flying capacitor negative connection
NC	7, 8	7, 14, 15		No internal connection
CP	9	8	I/O	Charge Pump flying capacitor positive connection
VDD	10	9	P	Supply voltage, connect to positive supply
GAIN	12	11	I	Gain set programming pin; connect a resistor to ground. See Table 1 for recommended resistor values
OUT_R	13	12	O	Output, right channel
-IN_R	14	13	I	Negative input, right channel

(1) I = input, O = output, P = power

SYSTEM BLOCK DIAGRAM

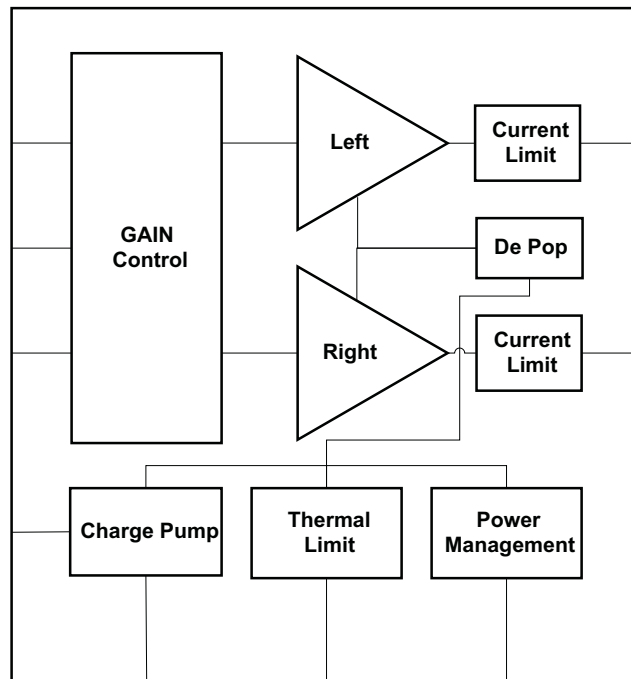

ORDERING INFORMATION⁽¹⁾

T _A	PACKAGE	DESCRIPTION
–40°C to 85°C	TPA6139A2PW	14-pin TSSOP
–40°C to 85°C	TPA6139A2RGT	16-pin QFN

(1) For the most current package and ordering information, see the Package Option Addendum at the end of this document, or see the TI Web site at www.ti.com.

THERMAL INFORMATION

THERMAL METRIC ⁽¹⁾		TPA6139A2 PW (14-Pin)	TPA6139A2 RGT (16-Pin)	UNITS
θ_{JA}	Junction-to-ambient thermal resistance	130	52	°C/W
θ_{JcTop}	Junction-to-case (top) thermal resistance	49	71	
θ_{JB}	Junction-to-board thermal resistance	63	26	
ψ_{JT}	Junction-to-top characterization parameter	3.6	3.0	
ψ_{JB}	Junction-to-board characterization parameter	62	26	
θ_{JcBot}	Junction-to-case (bottom) thermal resistance	N/A	9.8	

(1) For more information about traditional and new thermal metrics, see the *IC Package Thermal Metrics* application report, SPRA953.

TPA6139A2

SLOS700B – JANUARY 2011 – REVISED JUNE 2012

www.ti.com

ABSOLUTE MAXIMUM RATINGS⁽¹⁾

over operating free-air temperature range (unless otherwise noted)

		VALUE	UNIT
VDD to GND		–0.3 to 4	V
Input voltage, V_I		VSS–0.3 to VDD+0.3	V
$\overline{\text{MUTE}}$ to GND		–0.3 to VDD+0.3	V
Maximum operating junction temperature range, T_J		–40 to 150	°C
Storage temperature		–40 to 150	°C
Lead temperature		260	°C
ESD Protection – HBM	OUT_L, OUT_R	8	kV
	All other pins	2	kV

(1) Stresses beyond those listed under *absolute maximum ratings* may cause permanent damage to the device. These are stress ratings only, and functional operation of the device at these or any other conditions beyond those indicated under *recommended operating conditions* is not implied. Exposure to absolute-maximum-rated conditions for extended periods may affect device reliability.

RECOMMENDED OPERATING CONDITIONS

over operating free-air temperature range unless otherwise noted

			MIN	NOM	MAX	UNIT
VDD	Supply voltage	DC supply voltage	3.0	3.3	3.6	V
R_L				5		k Ω
V_{IL}	Low-level input voltage	$\overline{\text{MUTE}}$	38	40	43	%PVDD
V_{IH}	High-level input voltage	$\overline{\text{MUTE}}$	57	60	66	%PVDD
T_A	Free-air temperature		–40	25	85	°C

ELECTRICAL CHARACTERISTICS

 VDD = 3.3V, R_{Load} = 32Ω, T_A = 25°C, Charge pump: C_{CP} = 1.0 μF (unless otherwise noted)

PARAMETER		TEST CONDITIONS	MIN	TYP	MAX	UNIT
V _{OS}	Output offset voltage	VDD = 3.3 V, input ac-coupled		0.5	1	mV
PSRR	Power-supply rejection ratio		70	80		dB
V _{OH}	High-level output voltage	VDD = 3.3 V	3.1			V
V _{OL}	Low-level output voltage	VDD = 3.3 V			-3.05	V
V _{uvp_on}	PVDD, under voltage detection				2.8	V
V _{uvp_hysteresis}	PVDD, under voltage detection, hysteresis			200		mV
F _{cp}	Charge pump switching frequency			350		kHz
I _{IH}	High-level input current, $\overline{\text{MUTE}}$	VDD = 3.3 V, V _{IH} = VDD			1	μA
I _{IL}	Low-level input current, $\overline{\text{MUTE}}$	VDD = 3.3 V, V _{IL} = 0 V			1	μA
I (VDD)	Supply current, no load	VDD, $\overline{\text{MUTE}} = 3.3 \text{ V}$		25		mA
	Supply current, MUTED	VDD = 3.3 V, $\overline{\text{MUTE}} = \text{GND}$		25		mA
T _{sd}	Thermal shutdown			150		°C
	Thermal shutdown hysteresis			15		°C
P _O	Output Power, outputs in phase	THD+N = 1%, f = 1kHz, 32Ω load		25		mW
V _O	Output Voltage, outputs in phase	THD+N = 1%, f = 1kHz, 32Ω load		0.9		V _{rms}
		THD+N = 1%, f = 1kHz, 600Ω load		2.0		
THD+N	Total Harmonic distortion plus noise	f = 1kHz, 32Ω load, P _o = 25mW, -1x gain		0.03%		
THD+N	Total Harmonic distortion plus noise	f = 1kHz, 10kΩ load, V _o = 2 V _{rms} , -1x gain		0.005%		
ΔA _v	Gain matching	Between left and right channels		0.25		dB
Z _O	Output impedance when muted	$\overline{\text{MUTE}} = \text{GND}$			1	Ω
	Input to output attenuation when muted	$\overline{\text{MUTE}} = \text{GND}$		80		dB
SNR	Signal to noise ratio	A-weighted, AES17 filter, 1V _{rms} ref 32Ω load, -1x gain		99		dB
	Signal to noise ratio	A-weighted, AES17 filter, 2V _{rms} ref 600Ω load, -1x gain		105		dB
V _n	Noise voltage	A-weighted, AES17 filter, Gain = -2x		12		μV
	Slew rate			4.5		V/μs
G _{bw}	Unity Gain bandwidth			8		MHz
Crosstalk	Channel to channel	f = 1kHz, R _{load} = 32Ω, P _o = 25mW		-85		dB
V _{incm_pos}	Positive Common mode input voltage			+2.0		V
V _{incm_neg}	Negative Common mode input voltage			-2.0		V
I _{lim}	Output current limit			60		mA

TPA6139A2

SLOS700B – JANUARY 2011 – REVISED JUNE 2012

www.ti.com

PROGRAMMABLE GAIN SETTINGS

$V_{DD} = 3.3\text{ V}$, $R_{load} = 32\text{ k}\Omega$, $T_A = 25^\circ\text{C}$, Charge pump: = $C_{CP} 1\ \mu\text{F}$, $C_{IN} = 1.0\ \mu\text{F}$, 1 x gain select (unless otherwise noted)⁽¹⁾

PARAMETER	TEST CONDITIONS	TPA6139A2			UNIT
		MIN	TYP	MAX	
R_Tol Gain programming resistor tolerance				2%	
ΔA_V Gain matching	Between left and right channels		0.25		dB
	Gain step tolerance		0.10		dB
Gain steps	Gain resistor 2% tolerance				V/V
	249k or higher		-2.0		
	82k0		-1.0		
	49k2		-1.5		
	35k1		-2.3		
	27k3		-2.5		
	20k5		-3.0		
	15k4		-3.5		
	11k5		-4.0		
	9k09		-5.0		
	7k50		-5.6		
	6k19		-6.4		
5k11		-8.3			
3k90		-10.0			
Input impedance	Gain resistor 2% tolerance				k Ω
	249k or higher		37		
	82k0		55		
	49k2		44		
	35k1		33		
	27k3		31		
	20k5		28		
	15k4		24		
	11k5		22		
	9k09		18		
	7k50		17		
	6k19		15		
5k11		12			
3k90		10.0			

- (1) If pin 12, GAIN, is left floating an internal pull-up sets the gain to -2.0x
Gain setting is latched during power-up

TYPICAL CHARACTERISTICS, LINE DRIVER

$V_{DD} = 3.3\text{ V}$, $T_A = 25^\circ\text{C}$, $R_L = 2.5\text{ k}\Omega$, $C_{PUMP} = C_{(VSS)} = 10\text{ }\mu\text{F}$, Gain Step = -2V/V (unless otherwise noted)

THD+N vs OUTPUT VOLTAGE
3.3 V, 100 k Ω , 1 kHz

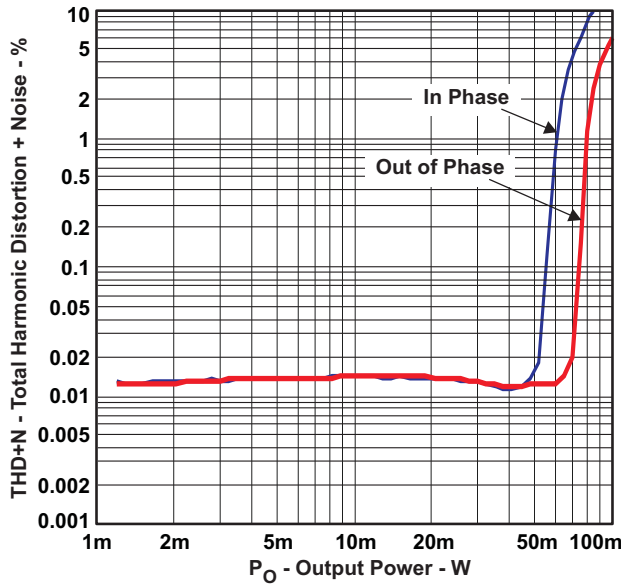

Figure 1.

THD+N vs OUTPUT VOLTAGE
3.3 V, 600 Ω load, 1 kHz

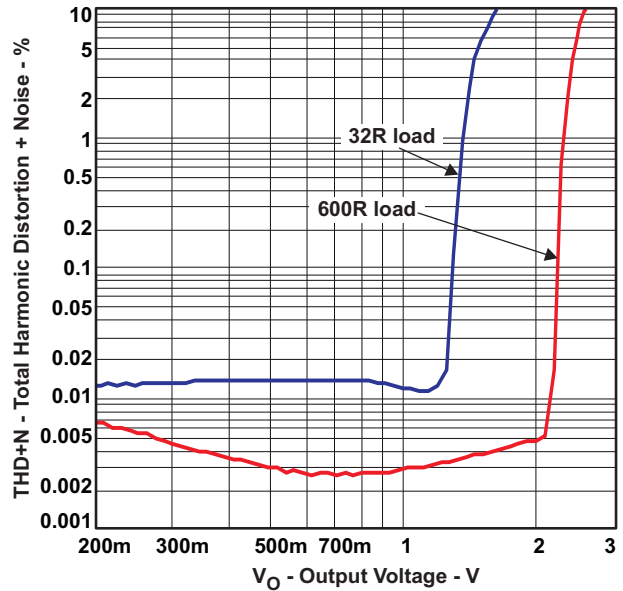

Figure 2.

CHANNEL SEPARATION
3.3 V, 5 k Ω load, 2 V_{rms}, Blue L to R, Red R to L

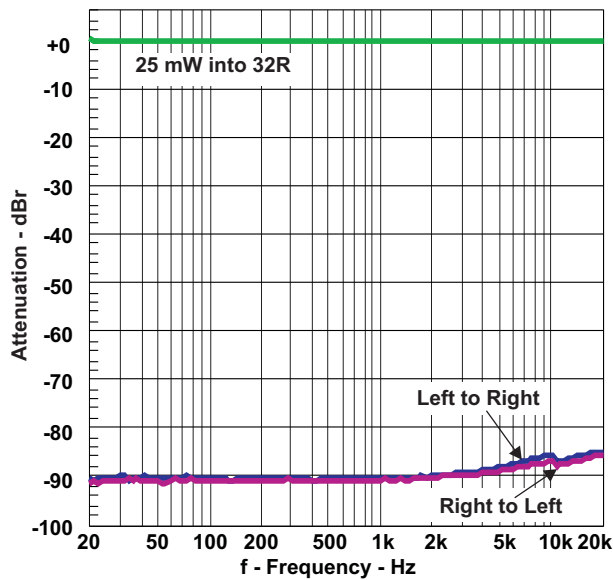

Figure 3.

FFT

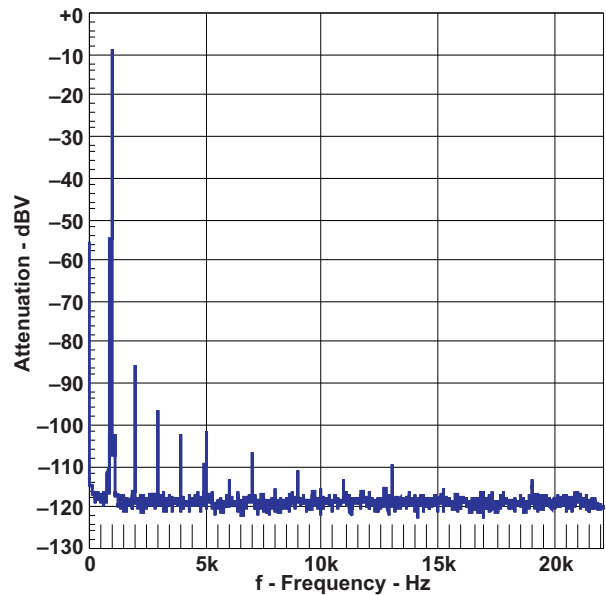

Figure 4.

TPA6139A2

SLOS700B – JANUARY 2011 – REVISED JUNE 2012

www.ti.com

TYPICAL CHARACTERISTICS, LINE DRIVER (continued)

$V_{DD} = 3.3\text{ V}$, $T_A = 25^\circ\text{C}$, $R_L = 2.5\text{ k}\Omega$, $C_{PUMP} = C_{(VSS)} = 10\text{ }\mu\text{F}$, Gain Step = -2V/V (unless otherwise noted)

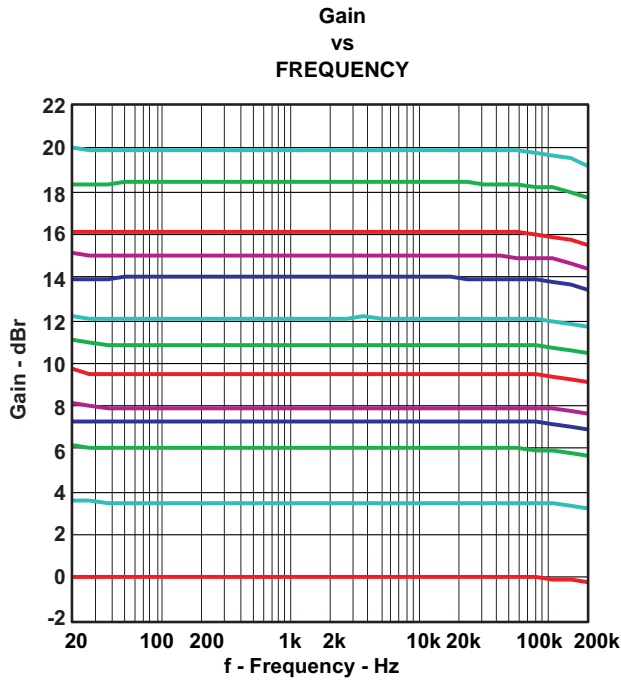

Figure 5.

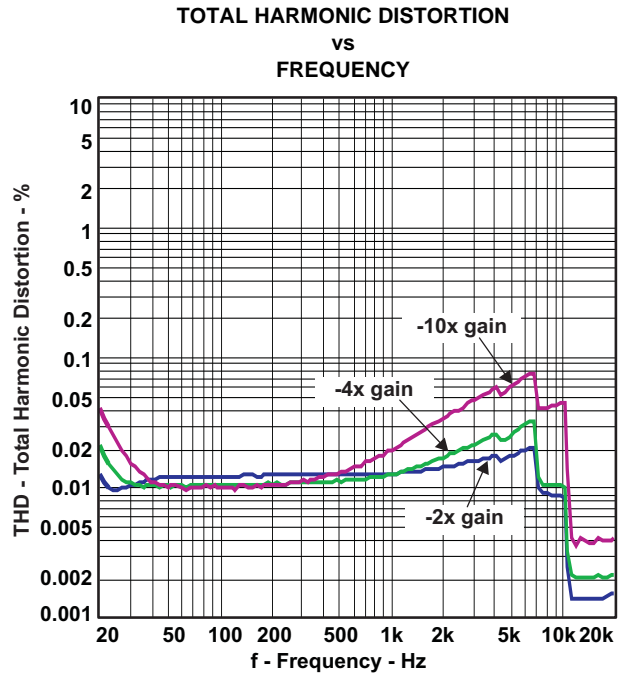

Figure 6.

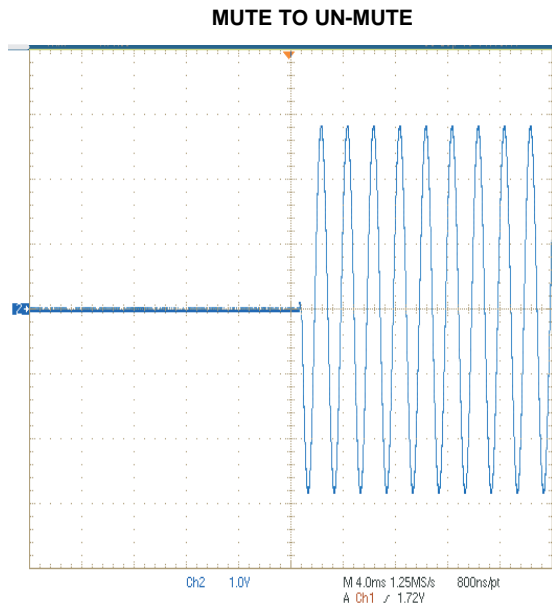

Figure 7.

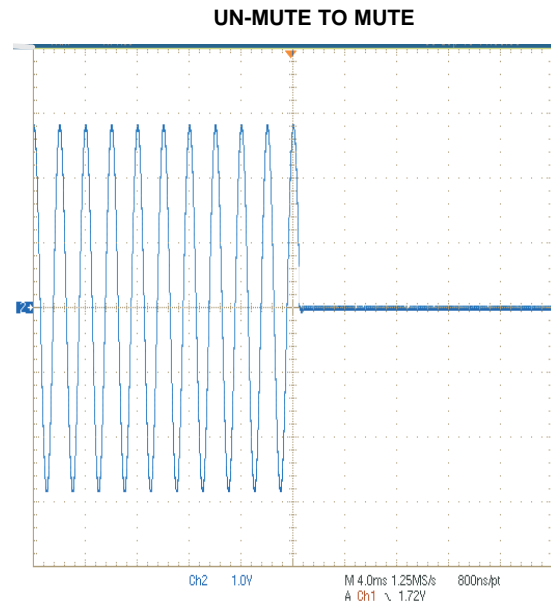

Figure 8.

APPLICATION INFORMATION

LINE DRIVER AMPLIFIERS

Single-supply line-driver amplifiers typically require dc-blocking capacitors. The top drawing in [Figure 9](#) illustrates the conventional line-driver amplifier connection to the load and output signal.

DC blocking capacitors are often large in value, and a mute circuit is needed during power up to minimize click and pop. The output capacitor and mute circuit consume PCB area and increase cost of assembly, and can reduce the fidelity of the audio output signal.

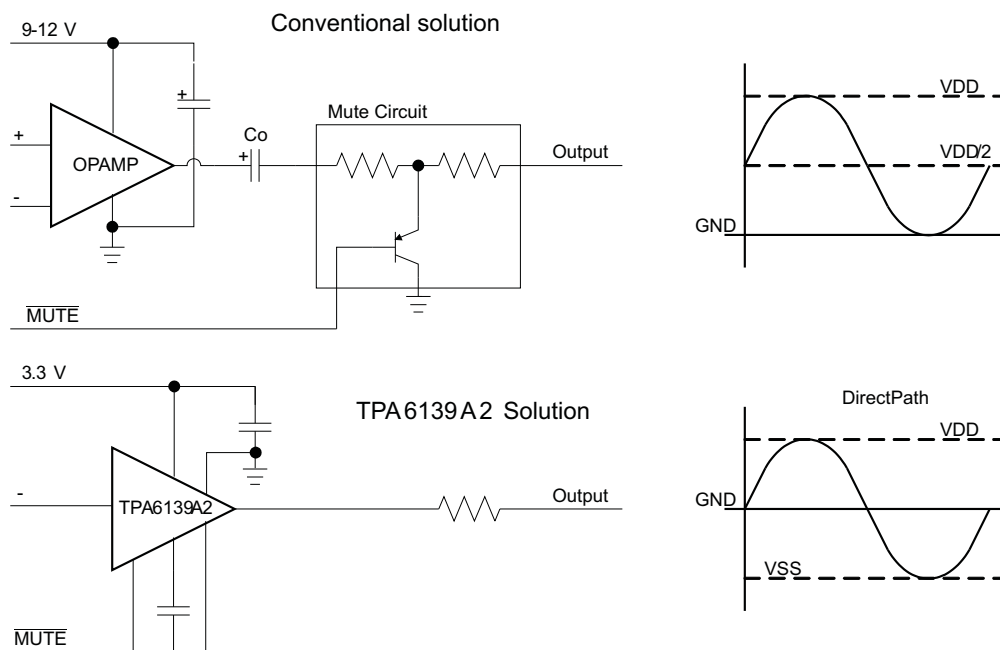

Figure 9. Conventional and DirectPath Line Driver

The DirectPath™ amplifier architecture operates from a single supply but makes use of an internal charge pump to provide a negative voltage rail.

Combining the user-provided positive rail and the negative rail generated by the IC, the device operates in what is effectively a split supply mode.

The output voltages are now centered at zero volts with the capability to swing to the positive rail or negative rail. Combining this with the built-in click and pop reduction circuit, the DirectPath™ amplifier requires no output dc blocking capacitors.

The bottom block diagram and waveform of [Figure 9](#) illustrate the ground-referenced line-driver architecture. This is the architecture of the TPA6139A2.

TPA6139A2

SLOS700B – JANUARY 2011 – REVISED JUNE 2012

www.ti.com

COMPONENT SELECTION

Charge Pump

The charge pump flying capacitor serves to transfer charge during the generation of the negative supply voltage. The VSS capacitor must be at least equal to the charge pump capacitor in order to allow maximum charge transfer. Low ESR capacitors are an ideal selection, and a value of 1µF is typical. Capacitor values that are smaller than 1µF cannot be recommended as it limits the negative voltage swing in low impedance loads.

Decoupling Capacitors

The TPA6139A2 is a DirectPath™ amplifier that requires adequate power supply decoupling to ensure that the noise and total harmonic distortion (THD) are low. A good low equivalent-series-resistance (ESR) ceramic capacitor, typically 1µF, placed as close as possible to the device VDD leads works best. Placing this decoupling capacitor close to the TPA6139A2 is important for the performance of the amplifier. For filtering lower frequency noise signals, a 10-µF or greater capacitor placed near the audio power amplifier also helps, but it is not required in most applications because of the high PSRR of this device.

Gain-Setting

The gain setting is programmed with the GAIN pin individually for line driver and headphone section. Gain setting is latched when the MUTE pin is set high. Table 1 lists the gain settings. The default gain with the gain-set pin left open is -2x.

Table 1. Gain Settings

Gain_set RESISTOR	GAIN	GAIN (dB)	INPUT RESISTANCE
No connect	-2.0x	6.0	37k
82k0	-1.0x	0.0	55k
49k2	-1.5x	3.5	44k
35k1	-2.3x	7.2	33k
27k3	-2.5x	8.0	31k
20k5	-3.0x	9.5	28k
15k4	-3.5x	10.9	24k
11k5	-4.0x	12.0	22k
9k09	-5.0x	14.0	18k
7k50	-5.6x	15.0	17k
6k19	-6.4x	16.1	15k
5k11	-8.3x	18.4	12k
3k90	-10x	20.0	10k

Internal Under Voltage Detection

The TPA6139A2 contains an internal precision band gap reference voltage and a comparator used to monitor the supply voltage, VDD. The internal VDD monitor is set at 2.8V with 200mV hysteresis.

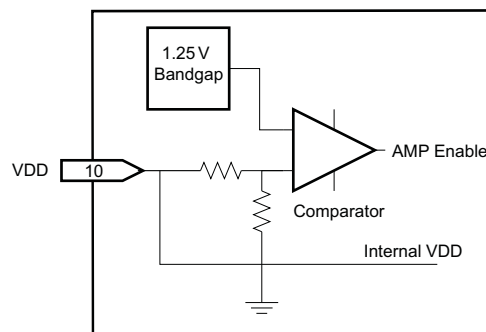

Input-Blocking Capacitors

DC input-blocking capacitors are required to be added in series with the audio signal into the input pins of the TPA6139A2. These capacitors block the dc portion of the audio source and allow the TPA6139A2 inputs to be properly biased to provide maximum performance. The input blocking capacitors also limit the DC gain to 1, limiting the DC-offset voltage at the output.

These capacitors form a high-pass filter with the input resistor, R_{IN} . The cutoff frequency is calculated using Equation 1. For this calculation, the capacitance used is the input-blocking capacitor and the resistance is the input resistor chosen from Table 1. Then the frequency and/or capacitance can be determined when one of the two values is given.

$$f_{C_{IN}} = \frac{1}{2\pi R_{IN} C_{IN}} \quad \text{or} \quad C_{IN} = \frac{1}{2\pi f_{C_{IN}} R_{IN}} \quad (1)$$

For a fixed cutoff frequency of 2Hz the size of the input capacitance is shown in the table below with the capacitors rounded up to nearest E6 values. For 20Hz cutoff simply divide the capacitor values with 10; e.g., for 1x gain, 150nF is needed.

Table 2. Input Capacitor for Different Gain and Cutoff

Gain_set RESISTOR	GAIN	Gain (dB)	INPUT RESISTANCE	2 Hz Cutoff
249k	-2.0x	6.0	37k	2.2 μ F
82k0	-1.0x	0.0	55k	1.5 μ F
49k2	-1.5x	3.5	44k	2.2 μ F
35k1	-2.3x	7.2	33k	3.3 μ F
27k3	-2.5x	8.0	31k	3.3 μ F
20k5	-3.0x	9.5	28k	3.3 μ F
15k4	-3.5x	10.9	24k	3.3 μ F
11k5	-4.0x	12.0	22k	4.7 μ F
9k09	-5.0x	14.0	18k	4.7 μ F
7k50	-5.6x	15.0	17k	4.7 μ F
6k19	-6.4x	16.1	15k	6.8 μ F
5k11	-8.3x	18.4	12k	6.8 μ F
3k90	-10x	20.0	10k	10 μ F

Pop-Free Power Up

Pop-free power up is ensured by keeping the $\overline{\text{MUTE}}$ low during power supply ramp up and down. The pin should be kept low until the input AC-coupling capacitors are fully charged before asserting the $\overline{\text{MUTE}}$ pin high to pre-charge the ac-coupling; and, pop-less power-up is achieved. Figure 10 illustrates the preferred sequence.

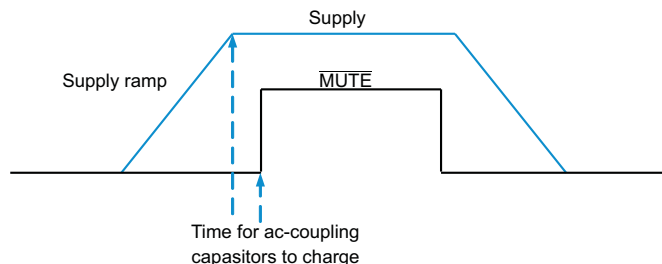

Figure 10. Power-Up Sequence

TPA6139A2

SLOS700B – JANUARY 2011 – REVISED JUNE 2012

www.ti.com

CAPACITIVE LOAD

The TPA6139A2 has the ability to drive a high capacitive load up to 220 pF directly. Higher capacitive loads can be accepted by adding a series resistor of 47 Ω or larger for the line driver output.

LAYOUT RECOMMENDATIONS

A proposed layout for the TPA6139A2 can be seen in the TPA6139A2EVM User's Guide (SLOU248), and the Gerber files can be downloaded from <http://focus.ti.com/docs/toolsw/folders/print/TPA6139A2evm.html>. To access this information, open the TPA6139A2 product folder and look in the Tools and Software folder.

Ground traces are recommended to be routed as a star ground to minimize hum interference. VDD, VSS decoupling capacitors and the charge pump capacitors should be connected with short traces.

PIN COMPATIBLE WITH THE DRV612

The TPA6139A2 stereo Headphone amplifier is pin compatible with the DRV612 . A single PCB layout can therefore be used with stuffing options for different board configurations.

APPLICATION CIRCUIT

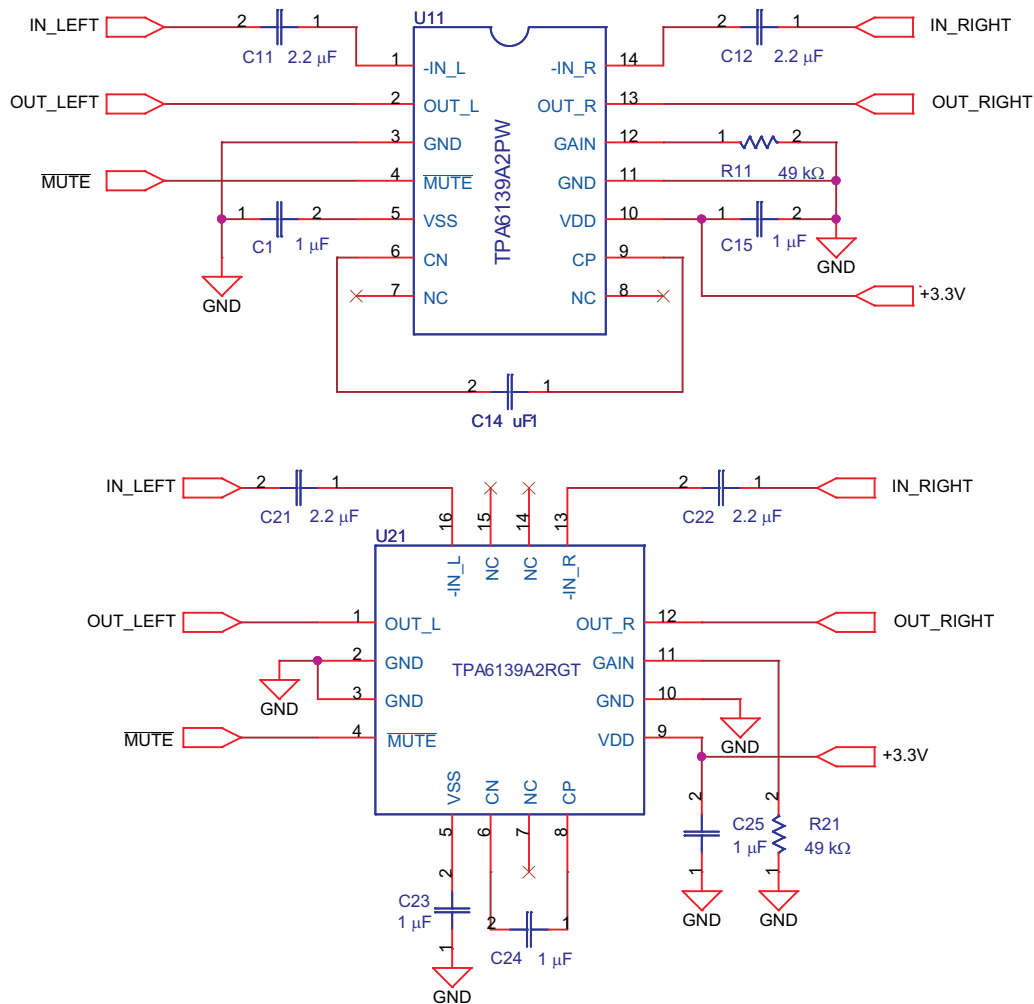

Figure 11. Single Ended Input and Output, Gain Set to -1.5x

REVISION HISTORY

NOTE: Page numbers in current version may differ from previous versions.

Changes from Original (January 2011) to Revision A	Page
• Changed "2.5-mW" to "25-mW" in Title line and added revision A - May 2011 pub date to Header information	1
• Changed pin assignment figures to match package outline drawings	2
• Changed conditions statement from " $R_{IN} = 10\text{ k}\Omega$, $R_{fb} = 20\text{ k}\Omega$ " to "Step = $-2V/V$ " for TYP CHARA, LINE DRIVER section	7
• Changed conditions statement from " $R_{IN} = 10\text{ k}\Omega$, $R_{fb} = 20\text{ k}\Omega$ " to "Step = $-2V/V$ " for TYP CHARA, LINE DRIVER section	8
Changes from Revision A (May 2011) to Revision B	
• Changed the RGT package From: Preview To: Production	2

PACKAGING INFORMATION

Orderable Device	Status (1)	Package Type	Package Drawing	Pins	Package Qty	Eco Plan (2)	Lead/Ball Finish	MSL Peak Temp (3)	Op Temp (°C)	Top-Side Markings (4)	Samples
TPA6139A2PW	ACTIVE	TSSOP	PW	14	90	Green (RoHS & no Sb/Br)	CU NIPDAU	Level-2-260C-1 YEAR	-40 to 85	TPA6139	Samples
TPA6139A2PWR	ACTIVE	TSSOP	PW	14	2000	Green (RoHS & no Sb/Br)	CU NIPDAU	Level-2-260C-1 YEAR	-40 to 85	TPA6139	Samples
TPA6139A2RGTR	ACTIVE	QFN	RGT	16	3000	Green (RoHS & no Sb/Br)	CU NIPDAU	Level-2-260C-1 YEAR	-40 to 150	T6139	Samples
TPA6139A2RGTT	ACTIVE	QFN	RGT	16	250	Green (RoHS & no Sb/Br)	CU NIPDAU	Level-2-260C-1 YEAR	-40 to 150	T6139	Samples

(1) The marketing status values are defined as follows:

ACTIVE: Product device recommended for new designs.

LIFEBUY: TI has announced that the device will be discontinued, and a lifetime-buy period is in effect.

NRND: Not recommended for new designs. Device is in production to support existing customers, but TI does not recommend using this part in a new design.

PREVIEW: Device has been announced but is not in production. Samples may or may not be available.

OBSELETE: TI has discontinued the production of the device.

(2) Eco Plan - The planned eco-friendly classification: Pb-Free (RoHS), Pb-Free (RoHS Exempt), or Green (RoHS & no Sb/Br) - please check <http://www.ti.com/productcontent> for the latest availability information and additional product content details.

TBD: The Pb-Free/Green conversion plan has not been defined.

Pb-Free (RoHS): TI's terms "Lead-Free" or "Pb-Free" mean semiconductor products that are compatible with the current RoHS requirements for all 6 substances, including the requirement that lead not exceed 0.1% by weight in homogeneous materials. Where designed to be soldered at high temperatures, TI Pb-Free products are suitable for use in specified lead-free processes.

Pb-Free (RoHS Exempt): This component has a RoHS exemption for either 1) lead-based flip-chip solder bumps used between the die and package, or 2) lead-based die adhesive used between the die and leadframe. The component is otherwise considered Pb-Free (RoHS compatible) as defined above.

Green (RoHS & no Sb/Br): TI defines "Green" to mean Pb-Free (RoHS compatible), and free of Bromine (Br) and Antimony (Sb) based flame retardants (Br or Sb do not exceed 0.1% by weight in homogeneous material)

(3) MSL, Peak Temp. -- The Moisture Sensitivity Level rating according to the JEDEC industry standard classifications, and peak solder temperature.

(4) Multiple Top-Side Markings will be inside parentheses. Only one Top-Side Marking contained in parentheses and separated by a "~" will appear on a device. If a line is indented then it is a continuation of the previous line and the two combined represent the entire Top-Side Marking for that device.

Important Information and Disclaimer: The information provided on this page represents TI's knowledge and belief as of the date that it is provided. TI bases its knowledge and belief on information provided by third parties, and makes no representation or warranty as to the accuracy of such information. Efforts are underway to better integrate information from third parties. TI has taken and continues to take reasonable steps to provide representative and accurate information but may not have conducted destructive testing or chemical analysis on incoming materials and chemicals. TI and TI suppliers consider certain information to be proprietary, and thus CAS numbers and other limited information may not be available for release.

In no event shall TI's liability arising out of such information exceed the total purchase price of the TI part(s) at issue in this document sold by TI to Customer on an annual basis.

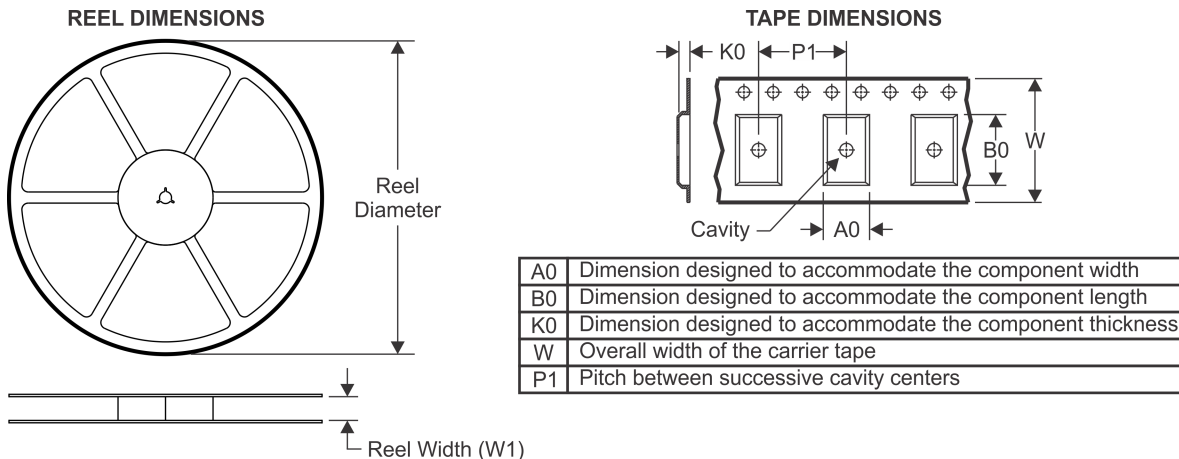
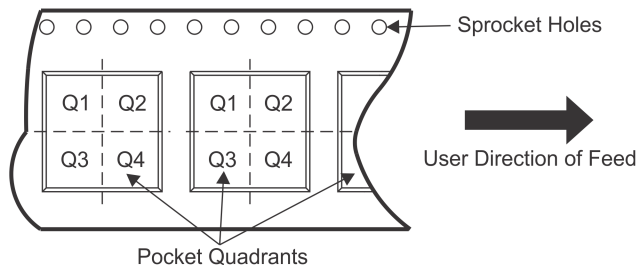
TAPE AND REEL INFORMATION

QUADRANT ASSIGNMENTS FOR PIN 1 ORIENTATION IN TAPE

*All dimensions are nominal

Device	Package Type	Package Drawing	Pins	SPQ	Reel Diameter (mm)	Reel Width W1 (mm)	A0 (mm)	B0 (mm)	K0 (mm)	P1 (mm)	W (mm)	Pin1 Quadrant
TPA6139A2PWR	TSSOP	PW	14	2000	330.0	12.4	6.9	5.6	1.6	8.0	12.0	Q1
TPA6139A2RGTR	QFN	RGT	16	3000	330.0	12.4	3.3	3.3	1.1	8.0	12.0	Q2
TPA6139A2RGTT	QFN	RGT	16	250	180.0	12.4	3.3	3.3	1.1	8.0	12.0	Q2

TAPE AND REEL BOX DIMENSIONS

*All dimensions are nominal

Device	Package Type	Package Drawing	Pins	SPQ	Length (mm)	Width (mm)	Height (mm)
TPA6139A2PWR	TSSOP	PW	14	2000	367.0	367.0	35.0
TPA6139A2RGTR	QFN	RGT	16	3000	367.0	367.0	35.0
TPA6139A2RGTT	QFN	RGT	16	250	210.0	185.0	35.0

PW (R-PDSO-G14)

PLASTIC SMALL OUTLINE

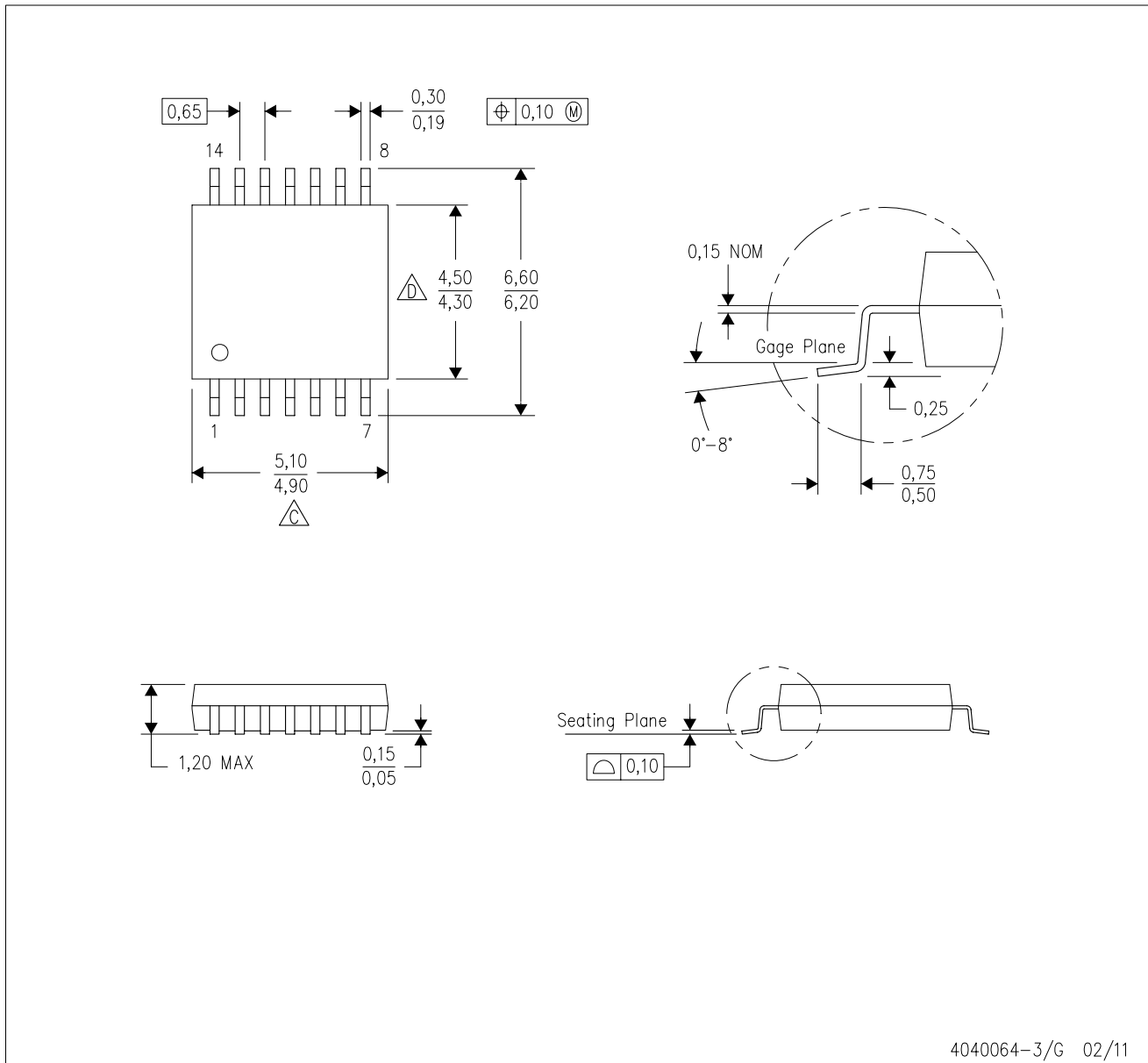

- NOTES:
- A. All linear dimensions are in millimeters. Dimensioning and tolerancing per ASME Y14.5M-1994.
 - B. This drawing is subject to change without notice.
 - C. Body length does not include mold flash, protrusions, or gate burrs. Mold flash, protrusions, or gate burrs shall not exceed 0,15 each side.
 - D. Body width does not include interlead flash. Interlead flash shall not exceed 0,25 each side.
 - E. Falls within JEDEC MO-153

PW (R-PDSO-G14)

PLASTIC SMALL OUTLINE



- NOTES:
- All linear dimensions are in millimeters.
 - This drawing is subject to change without notice.
 - Publication IPC-7351 is recommended for alternate designs.
 - Laser cutting apertures with trapezoidal walls and also rounding corners will offer better paste release. Customers should contact their board assembly site for stencil design recommendations. Refer to IPC-7525 for other stencil recommendations.
 - Customers should contact their board fabrication site for solder mask tolerances between and around signal pads.

RGT (S-PVQFN-N16)

PLASTIC QUAD FLATPACK NO-LEAD

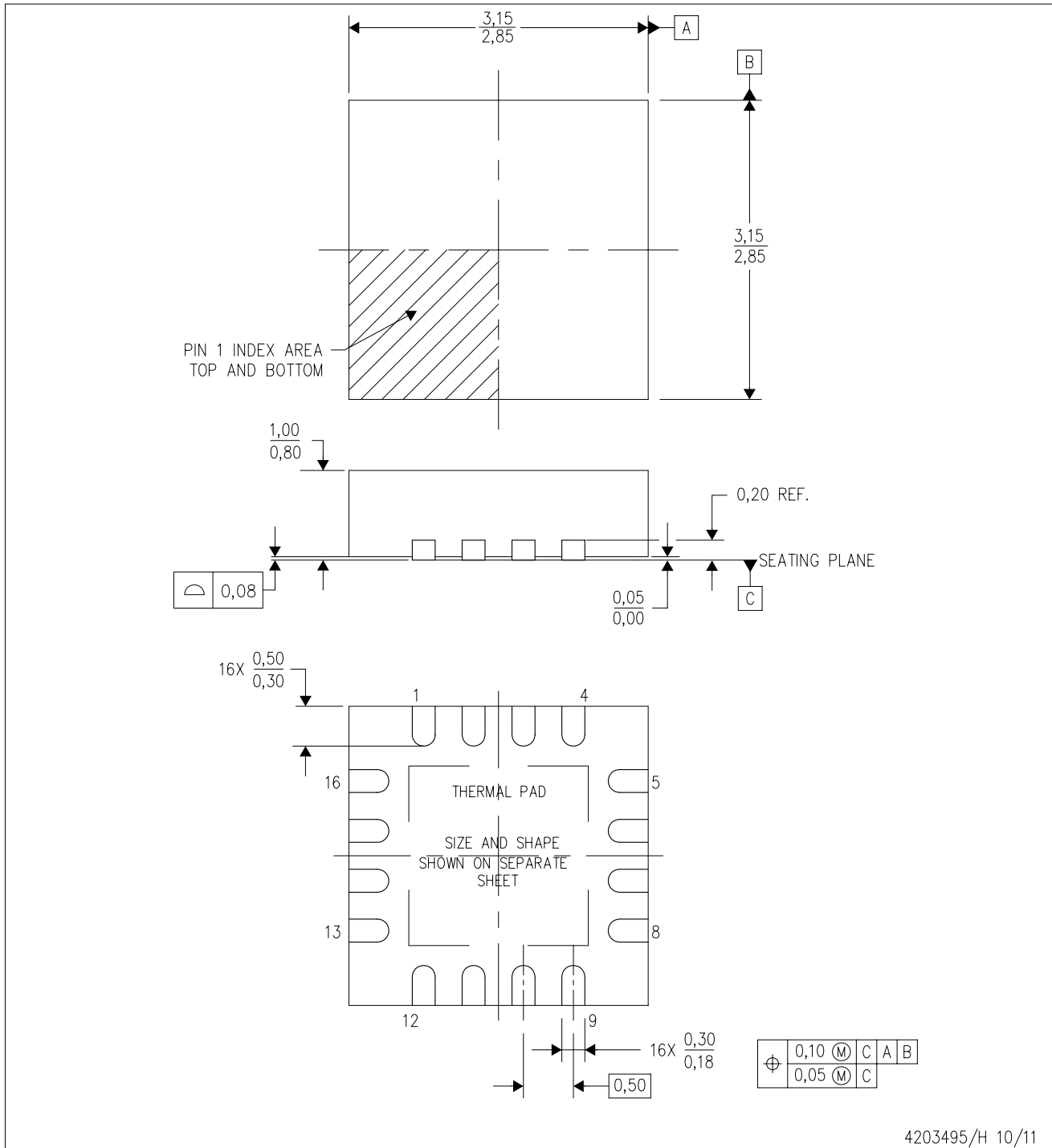

- NOTES:
- All linear dimensions are in millimeters. Dimensioning and tolerancing per ASME Y14.5M-1994.
 - This drawing is subject to change without notice.
 - Quad Flatpack, No-leads (QFN) package configuration.
 - The package thermal pad must be soldered to the board for thermal and mechanical performance.
 - See the additional figure in the Product Data Sheet for details regarding the exposed thermal pad features and dimensions.
 - Falls within JEDEC MO-220.

THERMAL PAD MECHANICAL DATA

RGT (S-PVQFN-N16)

PLASTIC QUAD FLATPACK NO-LEAD

THERMAL INFORMATION

This package incorporates an exposed thermal pad that is designed to be attached directly to an external heatsink. The thermal pad must be soldered directly to the printed circuit board (PCB). After soldering, the PCB can be used as a heatsink. In addition, through the use of thermal vias, the thermal pad can be attached directly to the appropriate copper plane shown in the electrical schematic for the device, or alternatively, can be attached to a special heatsink structure designed into the PCB. This design optimizes the heat transfer from the integrated circuit (IC).

For information on the Quad Flatpack No-Lead (QFN) package and its advantages, refer to Application Report, QFN/SON PCB Attachment, Texas Instruments Literature No. SLUA271. This document is available at www.ti.com.

The exposed thermal pad dimensions for this package are shown in the following illustration.

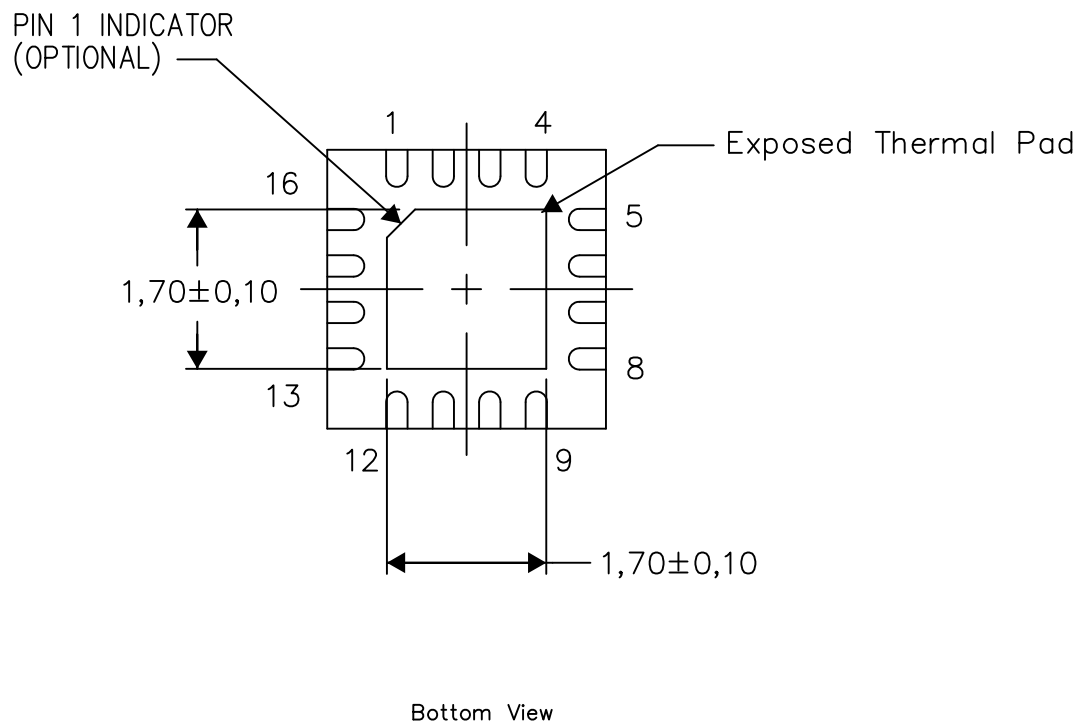

Exposed Thermal Pad Dimensions

4206349-4/Z 08/15

NOTE: All linear dimensions are in millimeters

RGT (S-PVQFN-N16)

PLASTIC QUAD FLATPACK NO-LEAD

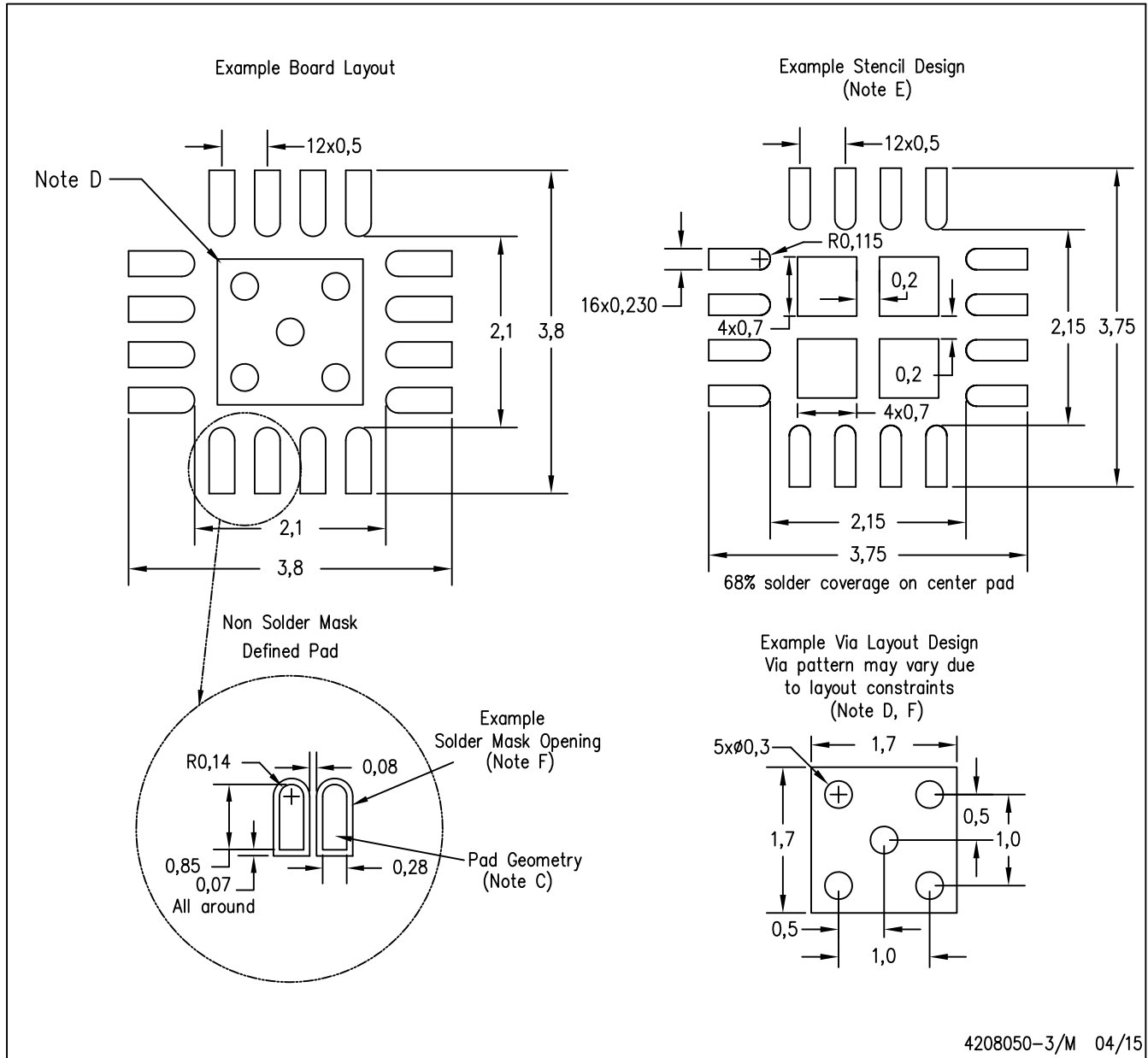

- NOTES:
- A. All linear dimensions are in millimeters.
 - B. This drawing is subject to change without notice.
 - C. Publication IPC-7351 is recommended for alternate designs.
 - D. This package is designed to be soldered to a thermal pad on the board. Refer to Application Note, QFN/SON PCB Attachment, Texas Instruments Literature No. SLUA271, and also the Product Data Sheets for specific thermal information, via requirements, and recommended board layout. These documents are available at www.ti.com <<http://www.ti.com>>.
 - E. Laser cutting apertures with trapezoidal walls and also rounding corners will offer better paste release. Customers should contact their board assembly site for stencil design recommendations. Refer to IPC 7525 for stencil design considerations.
 - F. Customers should contact their board fabrication site for minimum solder mask web tolerances between signal pads.

IMPORTANT NOTICE

Texas Instruments Incorporated and its subsidiaries (TI) reserve the right to make corrections, enhancements, improvements and other changes to its semiconductor products and services per JESD46, latest issue, and to discontinue any product or service per JESD48, latest issue. Buyers should obtain the latest relevant information before placing orders and should verify that such information is current and complete. All semiconductor products (also referred to herein as "components") are sold subject to TI's terms and conditions of sale supplied at the time of order acknowledgment.

TI warrants performance of its components to the specifications applicable at the time of sale, in accordance with the warranty in TI's terms and conditions of sale of semiconductor products. Testing and other quality control techniques are used to the extent TI deems necessary to support this warranty. Except where mandated by applicable law, testing of all parameters of each component is not necessarily performed.

TI assumes no liability for applications assistance or the design of Buyers' products. Buyers are responsible for their products and applications using TI components. To minimize the risks associated with Buyers' products and applications, Buyers should provide adequate design and operating safeguards.

TI does not warrant or represent that any license, either express or implied, is granted under any patent right, copyright, mask work right, or other intellectual property right relating to any combination, machine, or process in which TI components or services are used. Information published by TI regarding third-party products or services does not constitute a license to use such products or services or a warranty or endorsement thereof. Use of such information may require a license from a third party under the patents or other intellectual property of the third party, or a license from TI under the patents or other intellectual property of TI.

Reproduction of significant portions of TI information in TI data books or data sheets is permissible only if reproduction is without alteration and is accompanied by all associated warranties, conditions, limitations, and notices. TI is not responsible or liable for such altered documentation. Information of third parties may be subject to additional restrictions.

Resale of TI components or services with statements different from or beyond the parameters stated by TI for that component or service voids all express and any implied warranties for the associated TI component or service and is an unfair and deceptive business practice. TI is not responsible or liable for any such statements.

Buyer acknowledges and agrees that it is solely responsible for compliance with all legal, regulatory and safety-related requirements concerning its products, and any use of TI components in its applications, notwithstanding any applications-related information or support that may be provided by TI. Buyer represents and agrees that it has all the necessary expertise to create and implement safeguards which anticipate dangerous consequences of failures, monitor failures and their consequences, lessen the likelihood of failures that might cause harm and take appropriate remedial actions. Buyer will fully indemnify TI and its representatives against any damages arising out of the use of any TI components in safety-critical applications.

In some cases, TI components may be promoted specifically to facilitate safety-related applications. With such components, TI's goal is to help enable customers to design and create their own end-product solutions that meet applicable functional safety standards and requirements. Nonetheless, such components are subject to these terms.

No TI components are authorized for use in FDA Class III (or similar life-critical medical equipment) unless authorized officers of the parties have executed a special agreement specifically governing such use.

Only those TI components which TI has specifically designated as military grade or "enhanced plastic" are designed and intended for use in military/aerospace applications or environments. Buyer acknowledges and agrees that any military or aerospace use of TI components which have **not** been so designated is solely at the Buyer's risk, and that Buyer is solely responsible for compliance with all legal and regulatory requirements in connection with such use.

TI has specifically designated certain components as meeting ISO/TS16949 requirements, mainly for automotive use. In any case of use of non-designated products, TI will not be responsible for any failure to meet ISO/TS16949.

Products

Audio	www.ti.com/audio
Amplifiers	amplifier.ti.com
Data Converters	dataconverter.ti.com
DLP® Products	www.dlp.com
DSP	dsp.ti.com
Clocks and Timers	www.ti.com/clocks
Interface	interface.ti.com
Logic	logic.ti.com
Power Mgmt	power.ti.com
Microcontrollers	microcontroller.ti.com
RFID	www.ti-rfid.com
OMAP Applications Processors	www.ti.com/omap
Wireless Connectivity	www.ti.com/wirelessconnectivity

Applications

Automotive and Transportation	www.ti.com/automotive
Communications and Telecom	www.ti.com/communications
Computers and Peripherals	www.ti.com/computers
Consumer Electronics	www.ti.com/consumer-apps
Energy and Lighting	www.ti.com/energy
Industrial	www.ti.com/industrial
Medical	www.ti.com/medical
Security	www.ti.com/security
Space, Avionics and Defense	www.ti.com/space-avionics-defense
Video and Imaging	www.ti.com/video

TI E2E Community

e2e.ti.com