

# TPDxE05U06 1, 4, 6 Channel ESD Protection Device for Super-Speed (up to 6 GBPS) Interface

## 1 Features

- IEC 61000-4-2 Level 4 ESD Protection
  - $\pm 12$ -kV Contact Discharge
  - $\pm 15$ -kV Air Gap Discharge
- IEC 61000-4-4 EFT Protection
  - 80 A (5/50 ns)
- IEC 61000-4-5 Surge Protection
  - 2.5 A (8/20  $\mu$ s)
- IO Capacitance 0.42 pF to 0.5 pF (Typ)
- DC Breakdown Voltage 6.5 V (Min)
- Ultra low Leakage Current 10 nA (Max)
- Low ESD Clamping Voltage
- Industrial Temperature Range:  $-40^{\circ}\text{C}$  to  $125^{\circ}\text{C}$
- Easy Straight-Through Routing Packages

## 2 Applications

- HDMI 1.4*b*
- HDMI 2.0
- USB 3.0
- MHL
- LVDS Interfaces
- DisplayPort
- PCI-Express<sup>®</sup>
- eSata Interfaces
- V-by-One<sup>®</sup> HS

## 4 Simplified Schematic

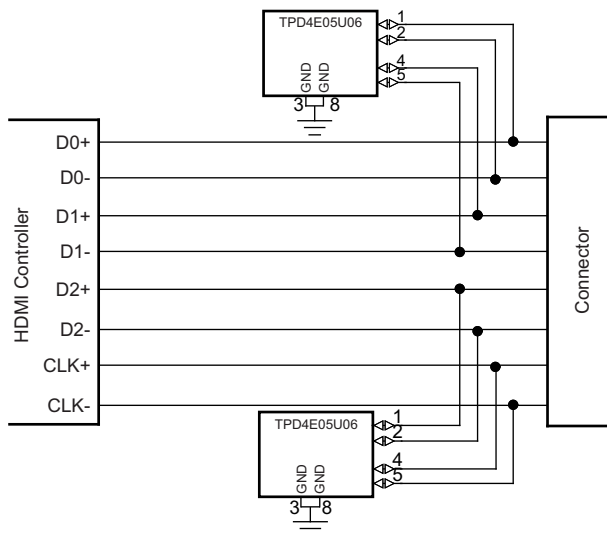

## 3 Description

The TPDxE05U06 is a family of unidirectional Transient Voltage Suppressor (TVS) based Electrostatic Discharge (ESD) protection diodes with ultra-low capacitance. Each device can dissipate ESD strikes above the maximum level specified by the IEC 61000-4-2 international standard. The TPDxE05U06's ultra-low loading capacitance makes it ideal for protecting any high-speed signal pins.

Typical applications for TPDxE05U06 includes high speed signal lines in HDMI 1.4*b*, HDMI 2.0, USB 3.0, MHL, LVDS, DisplayPort, PCI-Express<sup>®</sup>, eSata, and V-by-One<sup>®</sup> HS.

### Device Information<sup>(1)</sup>

PART NUMBER	PACKAGE	BODY SIZE (NOM)
TPD1E05U06	X2SON (2)	1.00 mm x 0.60 mm
TPD4E05U06	USON (10)	2.50 mm x 1.00 mm
TPD6E05U06	USON (14)	3.50 mm x 1.35 mm

(1) For all available packages, see the orderable addendum at the end of the datasheet.

### TPD4E05U06 Functional Block Diagram

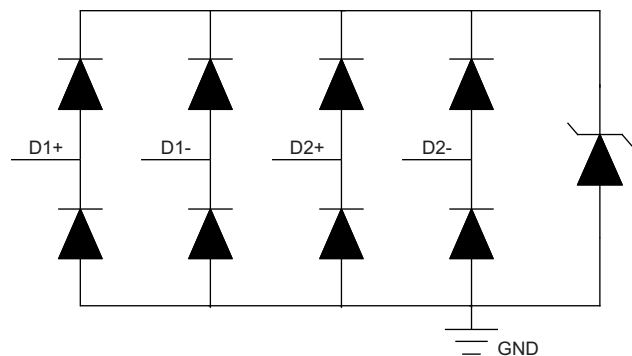

## Table of Contents

<b>1 Features</b> .....	<b>1</b>	8.3 Feature Description .....	<b>10</b>
<b>2 Applications</b> .....	<b>1</b>	8.4 Device Functional Modes .....	<b>10</b>
<b>3 Description</b> .....	<b>1</b>	<b>9 Application and Implementation</b> .....	<b>11</b>
<b>4 Simplified Schematic</b> .....	<b>1</b>	9.1 Application Information .....	<b>11</b>
<b>5 Revision History</b> .....	<b>2</b>	9.2 Typical Applications .....	<b>11</b>
<b>6 Pin Configuration and Functions</b> .....	<b>4</b>	<b>10 Layout</b> .....	<b>15</b>
<b>7 Specifications</b> .....	<b>5</b>	10.1 Layout Guidelines .....	<b>15</b>
7.1 Absolute Maximum Ratings .....	<b>5</b>	10.2 Layout Example .....	<b>15</b>
7.2 ESD Ratings .....	<b>5</b>	<b>11 Device and Documentation Support</b> .....	<b>17</b>
7.3 Recommended Operating Conditions .....	<b>5</b>	11.1 Related Links .....	<b>17</b>
7.4 Thermal Information .....	<b>5</b>	11.2 Community Resources .....	<b>17</b>
7.5 Electrical Characteristics .....	<b>6</b>	11.3 Trademarks .....	<b>17</b>
7.6 Typical Characteristics .....	<b>7</b>	11.4 Electrostatic Discharge Caution .....	<b>17</b>
<b>8 Detailed Description</b> .....	<b>9</b>	11.5 Glossary .....	<b>17</b>
8.1 Overview .....	<b>9</b>	<b>12 Mechanical, Packaging, and Orderable Information</b> .....	<b>17</b>
8.2 Functional Block Diagrams .....	<b>9</b>		

## 5 Revision History

NOTE: Page numbers for previous revisions may differ from page numbers in the current version.

<b>Changes from Revision H (May 2015) to Revision I</b>	<b>Page</b>
• Added Trademarks .....	<b>1</b>
• Corrected TPD6E05U06 Pin 13 name .....	<b>4</b>
• Corrected TLP definition .....	<b>6</b>

<b>Changes from Revision G (July 2014) to Revision H</b>	<b>Page</b>
• Added Additional Application .....	<b>1</b>
• Updated with HDMI 2.0 Eye Diagrams .....	<b>12</b>

<b>Changes from Revision F (November 2013) to Revision G</b>	<b>Page</b>
• Added 61000-4-4 EFT compliance .....	<b>1</b>
• Added Handling Ratings table .....	<b>5</b>
• Added Thermal Information table .....	<b>5</b>
• Added Detailed Description section .....	<b>9</b>
• Added Application and Implementation section .....	<b>11</b>
• Added Layout section .....	<b>15</b>

<b>Changes from Original (December 2012) to Revision A</b>	<b>Page</b>
• Added TPS2EUSB30A part to document .....	<b>1</b>

<b>Changes from Revision A (December 2012) to Revision B</b>	<b>Page</b>
• Added Insertion Loss Graphic .....	<b>8</b>
• Added Eye Diagrams .....	<b>12</b>

**Changes from Revision B (January 2013) to Revision C Page**

---

- Changed IO Capacitance range ..... 1
- Changed test conditions and typ values for  $V_{\text{clamp}}$  ..... 6
- Added typ  $R_{\text{DYN}}$  values for DQA and RVZ packages ..... 6
- Added  $C_L$  values for DQA and RVZ packages ..... 6
- Changed CURRENT vs VOLTAGE graphic ..... 7
- Changed Insertion Loss graphic ..... 8
- Changed HDMI Eye Diagrams ..... 12

---

**Changes from Revision C (March 2013) to Revision D Page**

---

- Updated Title. .... 1
- Removed Ordering Information table. .... 4

---

**Changes from Revision D (August 2013) to Revision E Page**

---

- Updated document formatting. .... 1
- Added additional application. .... 1

---

## 6 Pin Configuration and Functions

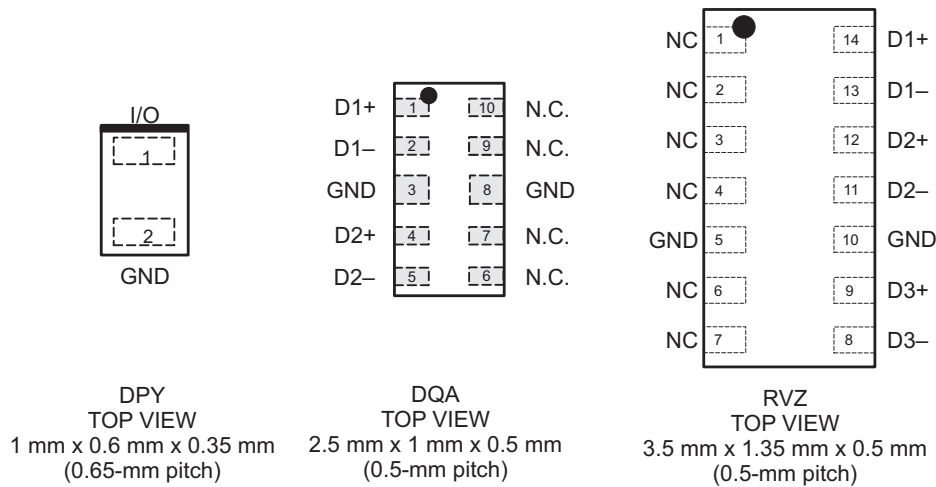

### Pin Functions TPD1E05U06 DPY

PIN		I/O	DESCRIPTION
NAME	X2SON		
I/O	1	I/O	ESD Protected Channel <sup>(1)</sup>
GND	2	Ground	Ground; Connect to ground

(1) Place as close to the connector as possible.

### Pin Functions TPD4E05U06 DQA

PIN		I/O	DESCRIPTION
NAME	USON		
D1+	1	I/O	ESD Protected Channel <sup>(1)</sup>
D1-	2	I/O	ESD Protected Channel <sup>(1)</sup>
D2+	4	I/O	ESD Protected Channel <sup>(1)</sup>
D2-	5	I/O	ESD Protected Channel <sup>(1)</sup>
NC	6, 7, 9, 10	–	Not Connected; Used for optional straight-through routing. Can be left floating or grounded.
GND	3, 8	Ground	Ground; Connect to ground

(1) Place as close to the connector as possible.

### Pin Functions TPD6E05U06 RVZ

PIN		I/O	DESCRIPTION
NAME	USON		
D1+	14	I/O	ESD Protected Channel <sup>(1)</sup>
D1-	13	I/O	ESD Protected Channel <sup>(1)</sup>
D2+	12	I/O	ESD Protected Channel <sup>(1)</sup>
D2-	11	I/O	ESD Protected Channel <sup>(1)</sup>
D3+	9	I/O	ESD Protected Channel <sup>(1)</sup>
D3-	8	I/O	ESD Protected Channel <sup>(1)</sup>
NC	1, 2, 3, 4, 6, 7	–	Not Connected; Used for optional straight-through routing. Can be left floating or grounded.
GND	5, 10	Ground	Ground; Connect to ground

(1) Place as close to the connector as possible.

## 7 Specifications

### 7.1 Absolute Maximum Ratings<sup>(1)(2)(3)</sup>

over operating free-air temperature range (unless otherwise noted)

		MIN	MAX	UNIT
Operating Temperature		-40	125	°C
Electrical Fast Transient	IEC 61000-4-4 (5/50 ns)		80	A
Peak Pulse	IEC 61000-4-5 Current (tp – 8/20 µs) <sup>(4)</sup>		2.5	A
	IEC 61000-4-5 Power (tp – 8/20 µs) <sup>(4)</sup>		40	W
T <sub>stg</sub>	Storage temperature range	-65	155	°C

- (1) Stresses beyond those listed under "absolute maximum ratings" may cause permanent damage to the device. These are stress ratings only, and functional operation of the device at these or any other conditions beyond those indicated in the operational sections of the specifications is not implied. Exposure to absolute maximum-rated conditions for extended periods may affect device reliability.
- (2) Absolute maximum ratings apply over recommended junction temperature range.
- (3) Voltages are with respect to GND unless otherwise noted.
- (4) Measured at 25°C.

### 7.2 ESD Ratings

		VALUE	UNIT	
V <sub>(ESD)</sub>	Electrostatic discharge	Human-body model (HBM), per ANSI/ESDA/JEDEC JS-001 <sup>(1)</sup>	±4000	
		Charged-device model (CDM), per JEDEC specification JESD22-C101 <sup>(2)</sup>	±1500	
		61000-4-2 ESD ratings	Contact	±12000
			Air	±15000

- (1) JEDEC document JEP155 states that 500-V HBM allows safe manufacturing with a standard ESD control process. Manufacturing with less than 500-V HBM is possible with the necessary precautions. Pins listed as ±4000 V may actually have higher performance.
- (2) JEDEC document JEP157 states that 250-V CDM allows safe manufacturing with a standard ESD control process. Manufacturing with less than 250-V CDM is possible with the necessary precautions. Pins listed as ±1500 V may actually have higher performance.

### 7.3 Recommended Operating Conditions

over operating free-air temperature range (unless otherwise noted)

		MIN	MAX	UNIT
V <sub>IO</sub>	Input pin voltage	0	5.5	V
T <sub>A</sub>	Operating free-air temperature	-40	125	°C

### 7.4 Thermal Information

THERMAL METRIC <sup>(1)</sup>		TPD1E05U06	TPD4E05U06	TPD6E05U06	UNIT
		DPY (X2SON)	DQA (USON)	RVZ (USON)	
		2 PINS	10 PINS	14 PINS	
R <sub>θJA</sub>	Junction-to-ambient thermal resistance	697.3	327	197.9	°C/W
R <sub>θJC(top)</sub>	Junction-to-case (top) thermal resistance	471	189.5	119.1	°C/W
R <sub>θJB</sub>	Junction-to-board thermal resistance	575.9	257.7	92.6	°C/W
Ψ <sub>JT</sub>	Junction-to-top characterization parameter	175.7	60.9	22	°C/W
Ψ <sub>JB</sub>	Junction-to-board characterization parameter	575.1	257	91.6	°C/W

- (1) For more information about traditional and new thermal metrics, see the *Semiconductor and IC Package Thermal Metrics* application report, [SPRA953](#).

## 7.5 Electrical Characteristics

over operating free-air temperature range (unless otherwise noted)

PARAMETER		TEST CONDITIONS	MIN	TYP	MAX	UNIT
$V_{RWM}$	Reverse stand-off voltage	$I_{IO} < 10 \mu A$			5.5	V
$V_{BR}$	Break-down Voltage	$I_{IO} = 1 \text{ mA}$	6		8.5	V
$V_{clamp}$	Clamp voltage	$I = 1 \text{ A}$ , TLP, I/O to ground <sup>(1)</sup>		10		V
		$I = 5 \text{ A}$ , TLP, I/O to ground <sup>(1)</sup>		14		
		$I = 1 \text{ A}$ , TLP, ground to I/O <sup>(1)</sup>		3		
		$I = 5 \text{ A}$ , TLP, ground to I/O <sup>(1)</sup>		7		
$I_{LEAK}$	Leakage current	$V_{IO} = 2.5 \text{ V}$		0.01	10	nA
$R_{DYN}$	DPY package dynamic resistance	I/O to GND <sup>(2)</sup>		0.8		$\Omega$
		GND to I/O <sup>(2)</sup>		0.8		
	DQA package dynamic resistance	I/O to GND <sup>(2)</sup>		0.8		$\Omega$
		GND to I/O <sup>(2)</sup>		0.8		
	RVZ package dynamic resistance	I/O to GND <sup>(2)</sup>		0.8		$\Omega$
		GND to I/O <sup>(2)</sup>		0.8		
<b>Capacitance</b>						
$C_L$	Line capacitance <sup>(3)</sup>	$V_{IO} = 2.5 \text{ V}$ , $f = 1 \text{ MHz}$ , I/O to GND	TPD1E05U06 DPY package	0.42		pF
			TPD4E05U06 DQA package	0.5		
			TPD6E05U06 RVZ package	0.47		
$\Delta C_{IO-TO-GND}$	Variation of channel input capacitance	GND Pin = 0 V, $F = 1 \text{ GHz}$ , $V_{BIAS} = 2.5 \text{ V}$ , channel_x pin to GND – channel_y pin to GND		0.05	0.07	pF
$C_{CROSS}$	Channel to channel input capacitance	GND Pin = 0 V, $F = 1 \text{ GHz}$ , $V_{BIAS} = 2.5 \text{ V}$ , between channel pins		0.01	0.06	pF

(1) Transmission Line Pulse (TLP) with 100 ns width, 200 ps rise time.

 (2) Extraction of  $R_{DYN}$  using least squares fit of TLP characteristics between  $I = 10 \text{ A}$  and  $I = 20 \text{ A}$ .

(3) Capacitance data is taken at 25°C.

## 7.6 Typical Characteristics

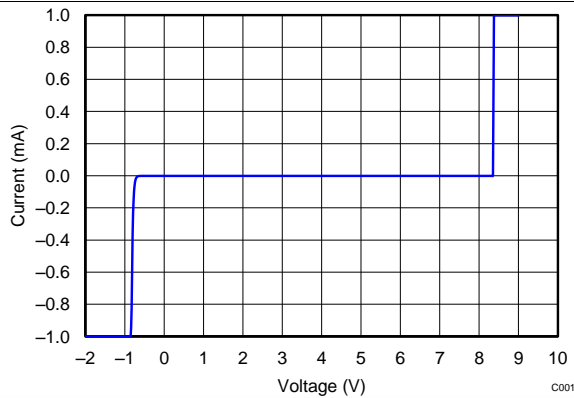

Figure 1. DC Voltage Sweep I-V Curve

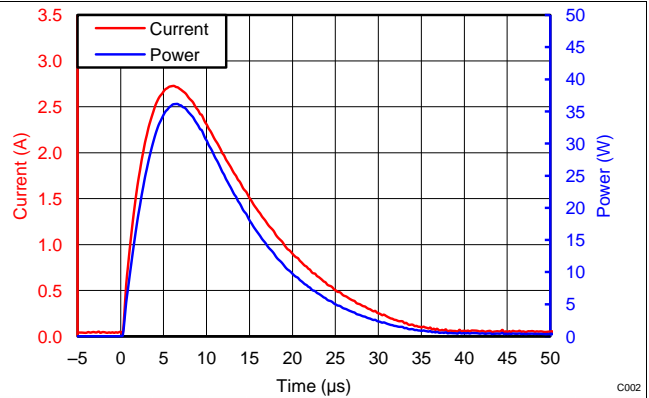

Figure 2. Surge Curve ( $t_p = 8/20 \mu s$ ), Pin IO to GND

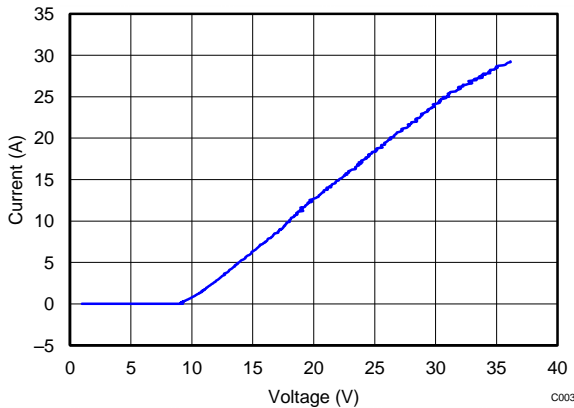

Figure 3. Positive TLP Plot IO to GND

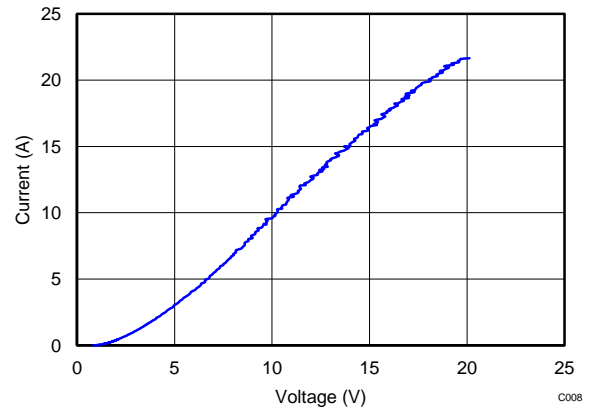

Figure 4. Negative TLP Plot IO to GND

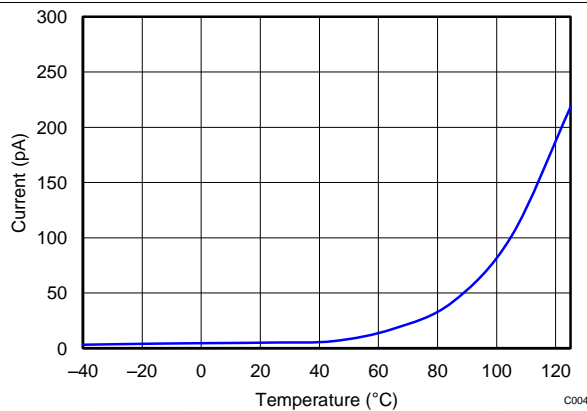

Figure 5. Leakage vs Temperature

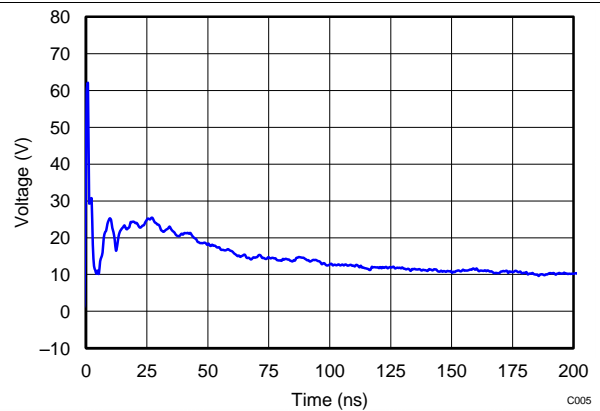
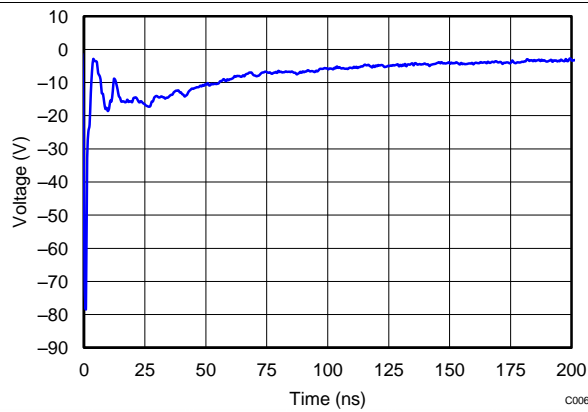
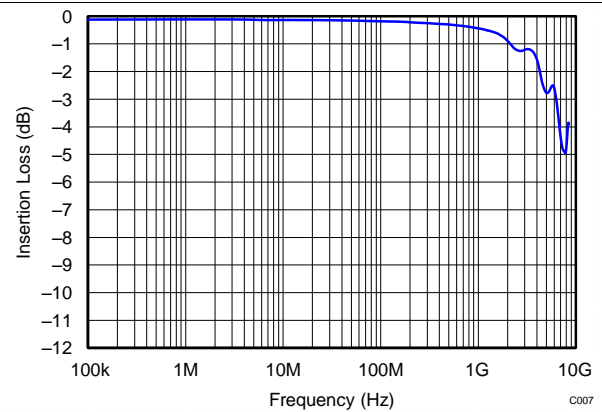

Figure 6. +8-kV IEC Waveform

**Typical Characteristics (continued)**



**Figure 7. -8-kV IEC Waveform**



**Figure 8. TPD1E05U06 Insertion Loss**

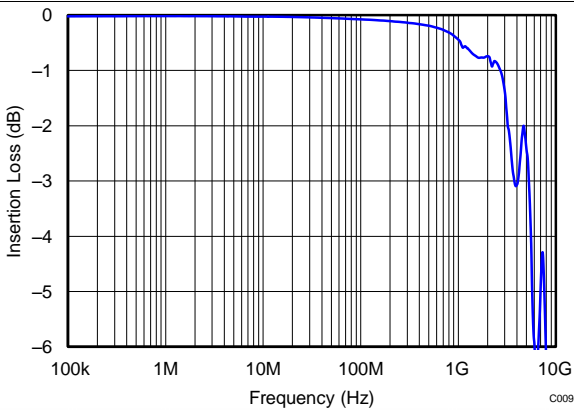

**Figure 9. TPD4E05U06 Insertion Loss**

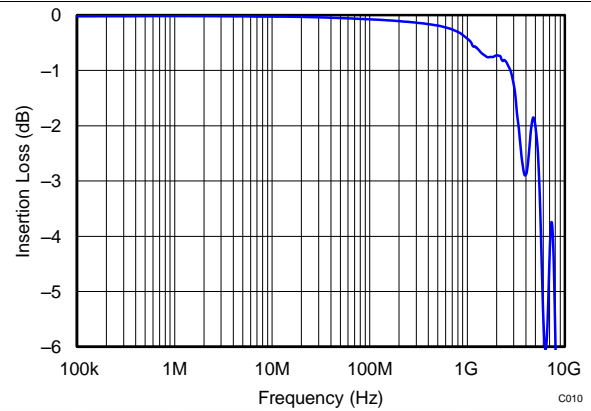

**Figure 10. TPD6E05U06 Insertion Loss**

## 8 Detailed Description

### 8.1 Overview

The TPDxE05U06 is a family of unidirectional Transient Voltage Suppressor (TVS) based Electrostatic Discharge (ESD) protection diodes with ultra-low capacitance. Each device can dissipate ESD strikes above the maximum level specified by the IEC 61000-4-2 international standard. The TPDxE05U06's ultra-low loading capacitance makes it ideal for protecting any high-speed signal pins.

### 8.2 Functional Block Diagrams

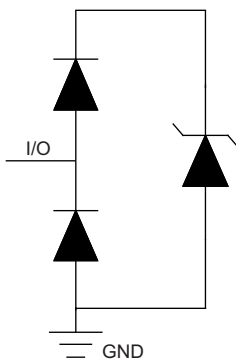

**Figure 11. TPD1E05U06 Block Diagram**

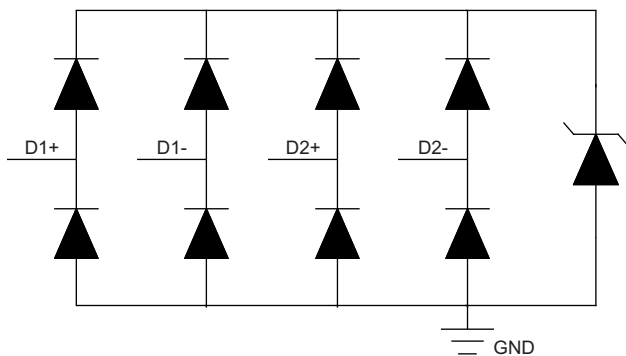

**Figure 12. TPD4E05U06 Block Diagram**

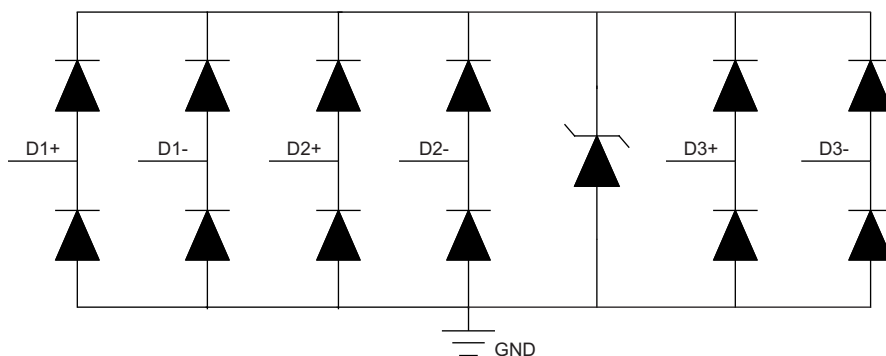

**Figure 13. TPD6E05U06 Block Diagram**

### 8.3 Feature Description

The TPDxE05U06 is a family of unidirectional Transient Voltage Suppressor (TVS) Electrostatic Discharge (ESD) protection diodes with ultra-low capacitance. Each device can dissipate ESD strikes above the maximum level specified by the IEC 61000-4-2 international standard. The TPDxE05U06's ultra-low loading capacitance makes it ideal for protecting any high-speed signal pins.

#### 8.3.1 ±15-kV IEC61000-4-2 Level 4 ESD Protection

The I/O pins can withstand ESD events up to ±12-kV contact and ±15-kV air. An ESD/surge clamp diverts the current to ground.

#### 8.3.2 IEC61000-4-4 EFT Protection

The I/O pins can withstand an electrical fast transient burst of up to 80 A (5/50 ns waveform, 4 kV with 50 Ω impedance). An ESD/surge clamp diverts the current to ground. This has been validated on the TPD4E05U06 only.

#### 8.3.3 IEC61000-4-5 Surge Protection

The I/O pins can withstand surge events up to 2.5 A and 40 W (8/20 μs waveform). An ESD/surge clamp diverts this current to ground.

#### 8.3.4 I/O Capacitance

The capacitance between each I/O pin to ground is 0.42 pF (TPD1E05U06), 0.5 pF (TPD4E05U06) or 0.47 pF (TPD6E05U06). These devices support data rates up to 6.0 Gbps.

#### 8.3.5 DC Breakdown Voltage

The DC breakdown voltage of each I/O pin is a minimum of 6 V. This ensures that sensitive equipment is protected from surges above the reverse standoff voltage of 5 V.

#### 8.3.6 Ultra-Low Leakage Current

The I/O pins feature an ultra-low leakage current of 10 nA (max) with a bias of 2.5 V.

#### 8.3.7 Low ESD Clamping Voltage

The I/O pins feature an ESD clamp that is capable of clamping the voltage to 10 V ( $I_{PP} = 1$  A).

#### 8.3.8 Industrial Temperature Range

This device features an industrial operating range of –40°C to 125°C.

#### 8.3.9 Easy Flow-Through Routing

The layout of this device makes it simple and easy to add protection to an existing layout. The packages offers flow-through routing, requiring minimal modification to an existing layout.

### 8.4 Device Functional Modes

TPDxE05U06 is a passive integrated circuit that triggers when voltages are above VBR or below the lower diodes  $V_f$  (–0.6 V). During ESD events, voltages as high as ±15 kV (air) can be directed to ground via the internal diode network. Once the voltages on the protected line fall below the trigger levels of TPDxE05U06 (usually within 10's of nano-seconds) the device reverts to passive.

## 9 Application and Implementation

### NOTE

Information in the following applications sections is not part of the TI component specification, and TI does not warrant its accuracy or completeness. TI's customers are responsible for determining suitability of components for their purposes. Customers should validate and test their design implementation to confirm system functionality.

### 9.1 Application Information

TPDxE05U06 is a diode type TVS which is typically used to provide a path to ground for dissipating ESD events on hi-speed signal lines between a human interface connector and a system. As the current from ESD passes through the TVS, only a small voltage drop is present across the diode. This is the voltage presented to the protected IC. The low  $R_{DYN}$  of the triggered TVS holds this voltage,  $V_{CLAMP}$ , to a safe level for the protected IC.

### 9.2 Typical Applications

#### 9.2.1 HDMI 2.0 Application

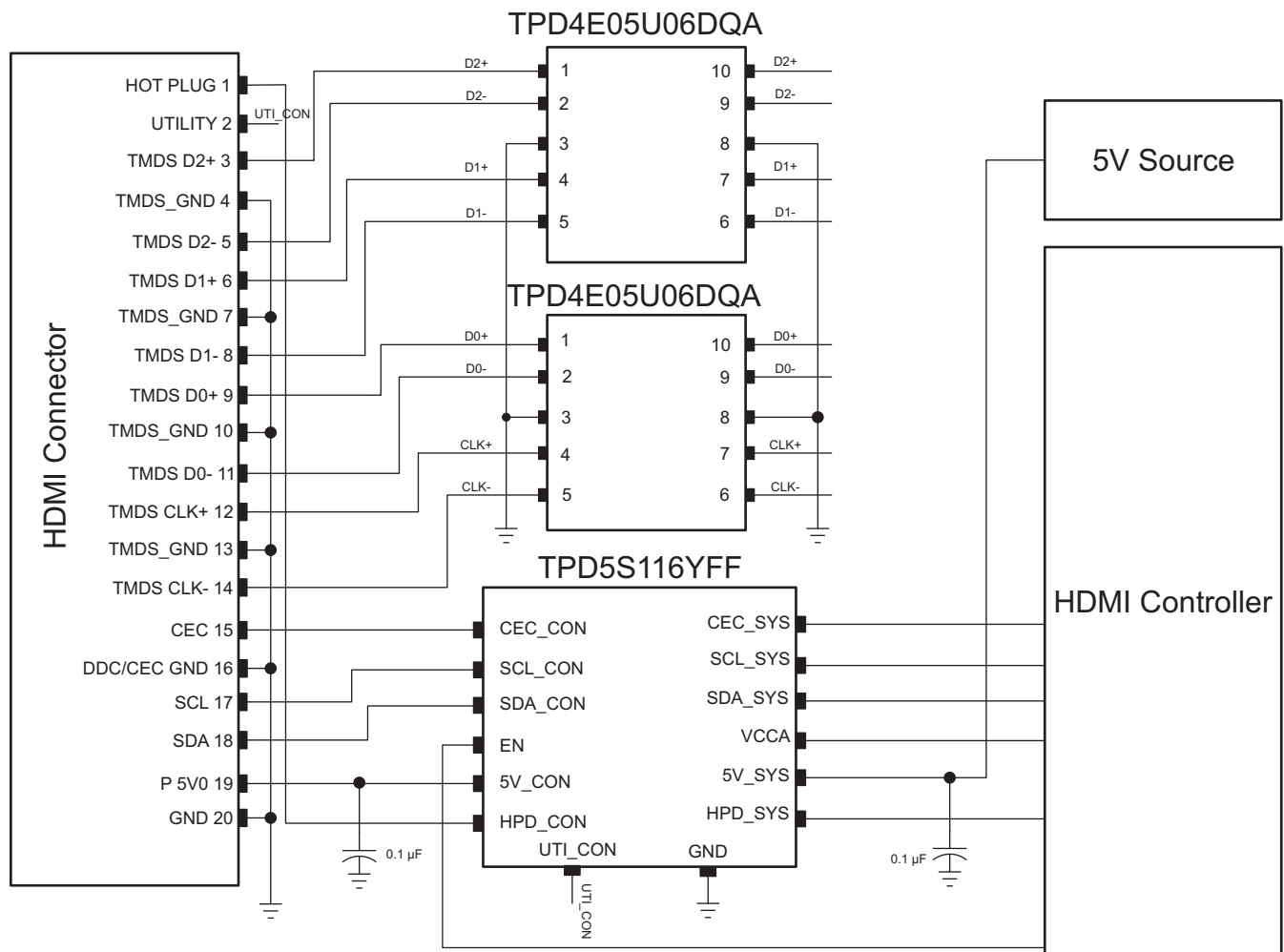

Figure 14. HDMI 2.0 Schematic

## Typical Applications (continued)

### 9.2.1.1 Design Requirements

For this design example, two TPD4E05U06 devices, and a TPD5S116 are being used in an HDMI 2.0 application. This will provide a complete port protection scheme.

Given the HDMI 2.0 application, the following parameters are known.

DESIGN PARAMETER	VALUE
Signal range on Pins 1, 2, 4, or 5	0 V to 5 V
Operating Frequency	3.0 GHz

### 9.2.1.2 Detailed Design Procedure

To begin the design process, some parameters must be decided upon; the designer needs to know the following:

- Signal range on all the protected lines
- Operating frequency

#### 9.2.1.2.1 Signal Range on Pin 1, 2, 4, or 5

TPD4E05U06 has 4 identical protection channels for signal lines. The symmetry of the device provides flexibility when selecting which of the 4 I/O channels will protect which signal lines. Any I/O will support a signal range of 0 to 5.5 V.

### 9.2.1.3 Application Curves

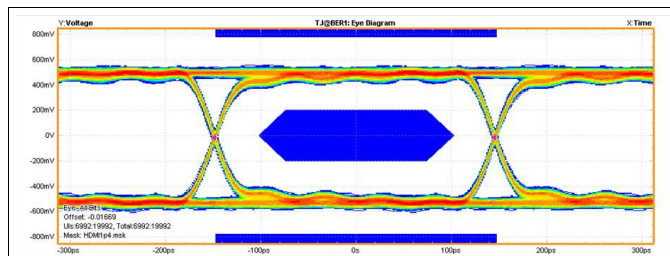

Figure 15. 3.4 Gbps HDMI 1.4 TP1 Eye Diagram Unpopulated EVM

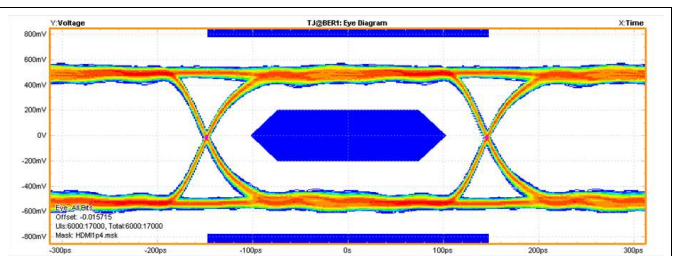

Figure 16. 3.4 Gbps HDMI 1.4 TP1 Eye Diagram TPD1E05U06

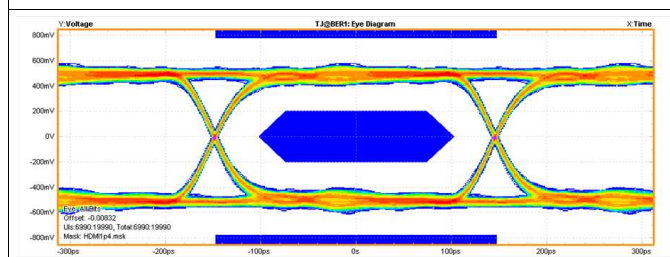

Figure 17. 3.4 Gbps HDMI 1.4 TP1 Eye Diagram TPD4E05U06

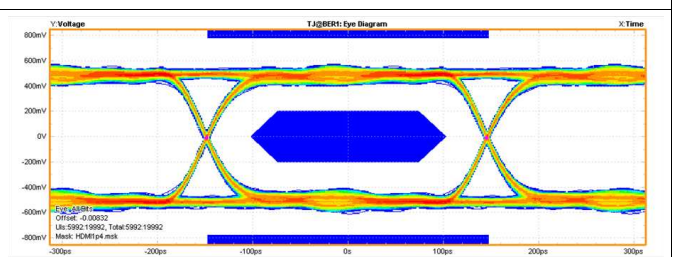

Figure 18. 3.4 Gbps HDMI 1.4 TP1 Eye Diagram TPD6E05U06

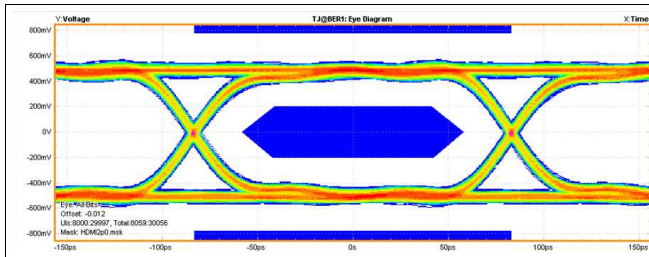

Figure 19. 6 Gbps HDMI 2.0 (TP1) Eye Diagram Unpopulated EVM

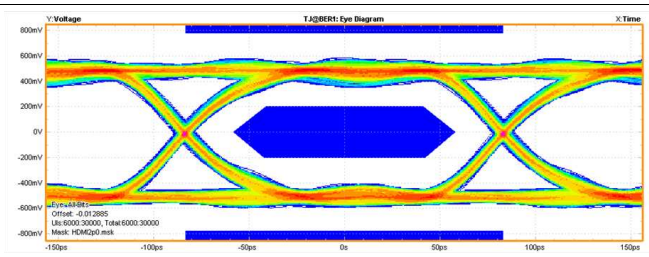

Figure 20. 6 Gbps HDMI 2.0 (TP1) Eye Diagram TPD1E05U06

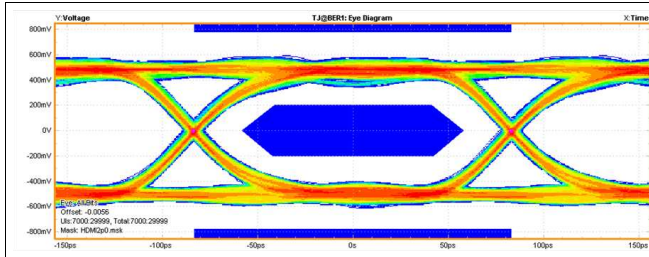

Figure 21. 6 Gbps HDMI 2.0 (TP1) Eye Diagram TPD4E05U06

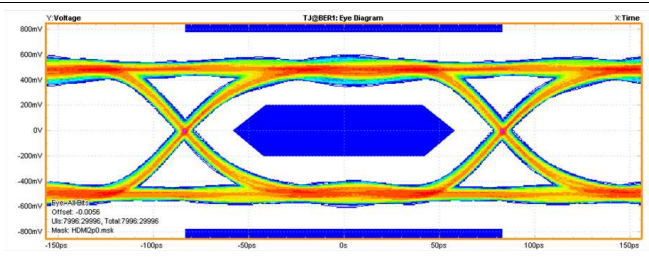
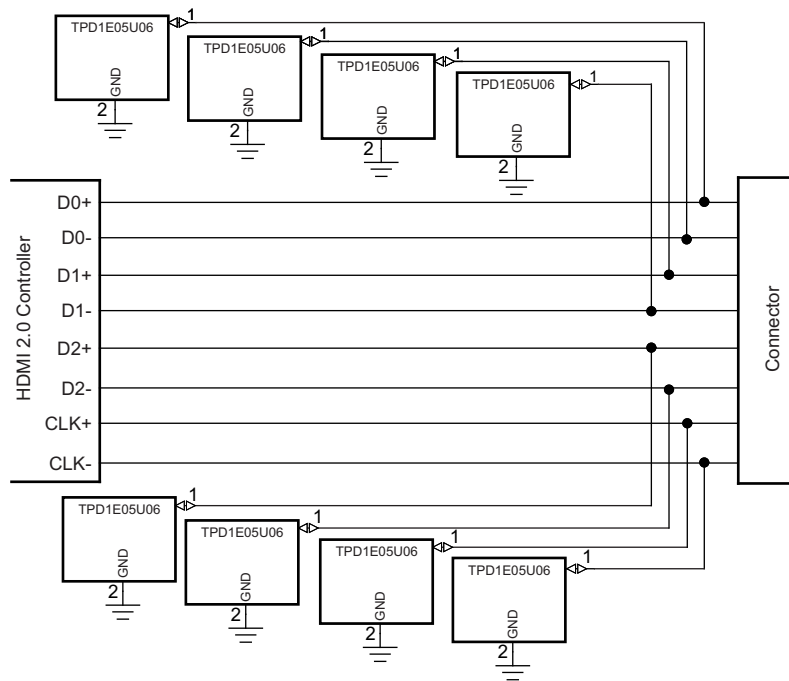

Figure 22. 6 Gbps HDMI 2.0 (TP1) Eye Diagram TPD6E05U06

## 9.2.2 HDMI 2.0 Application



**Figure 23. HDMI 2.0 Schematic**

### 9.2.2.1 Design Requirements

For this design example, the TPD1E05U06 and the TPD5S116 will be used to protect the data pairs and control lines of the HDMI 2.0 connection. This will provide full HDMI 2.0 port protection.

Given the HDMI 2.0 application, the following parameters are known.

DESIGN PARAMETER	VALUE
Signal Range on Data Lines	0 V to 5 V
Operating Frequency	3 GHz

### 9.2.2.2 Detailed Design Procedure

To begin the design process, some parameters must be decided upon; the designer needs to know the following:

- Signal range on all the protected lines
- Operating frequency

#### 9.2.2.2.1 Signal Range

TPD1E05U06 has 1 protection channel for signal lines, supporting a signal range of 0 to 5.5 V.

#### 9.2.2.2.2 Operating Frequency

The TPD1E05U06 has 0.42 pF of capacitance, which supports HDMI 2.0 data rates.

### 9.2.2.3 Application Curves

Refer to [Application Curves](#)

## 10 Layout

### 10.1 Layout Guidelines

- The optimum placement is as close to the connector as possible.
  - EMI during an ESD event can couple from the trace being struck to other nearby unprotected traces, resulting in early system failures.
  - The PCB designer needs to minimize the possibility of EMI coupling by keeping any unprotected traces away from the protected traces which are between the TVS and the connector.
- Route the protected traces as straight as possible.
- Eliminate any sharp corners on the protected traces between the TVS and the connector by using rounded corners with the largest radii possible.
  - Electric fields tend to build up on corners, increasing EMI coupling.

### 10.2 Layout Example

#### 10.2.1 TPD4E05U06 Layout Example

This application is typical of an HDMI 1.4 layout.

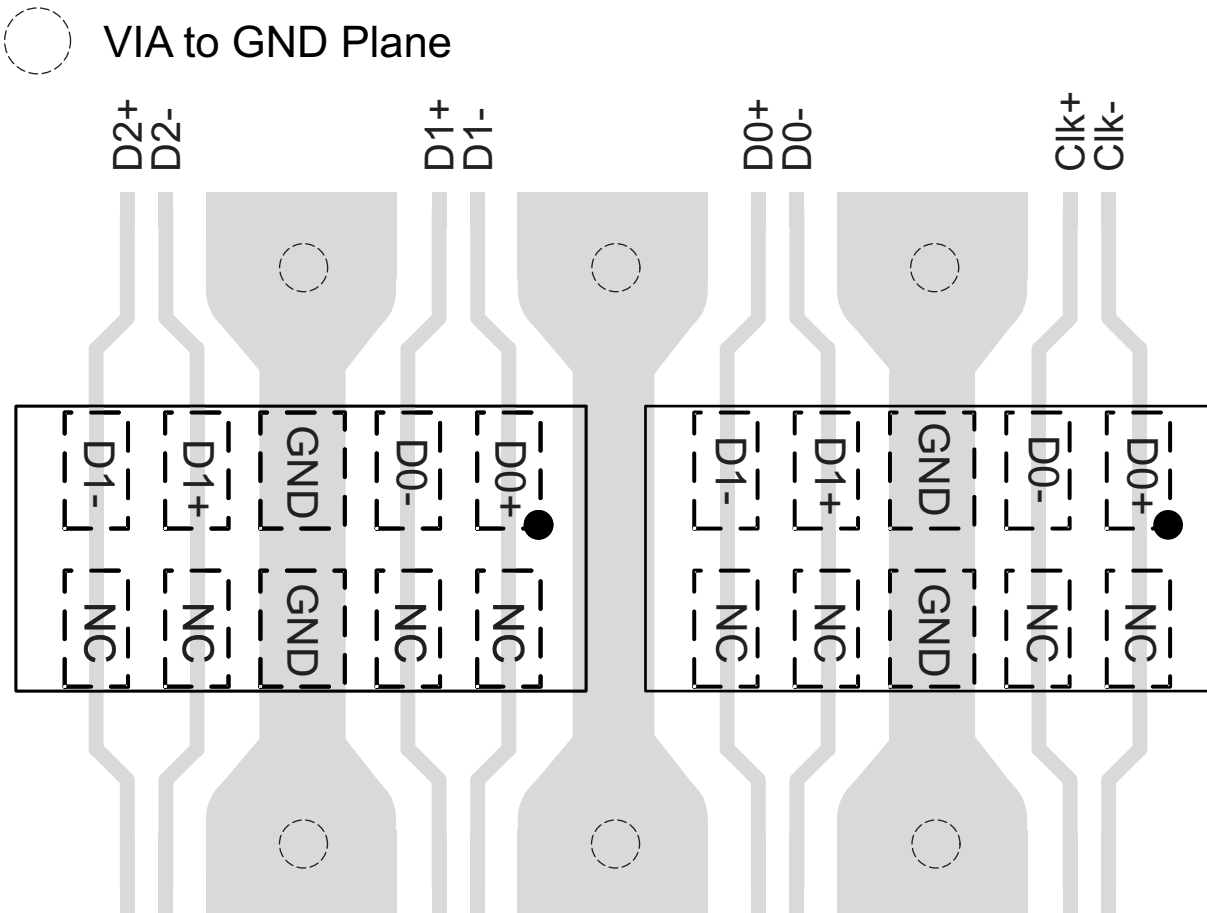
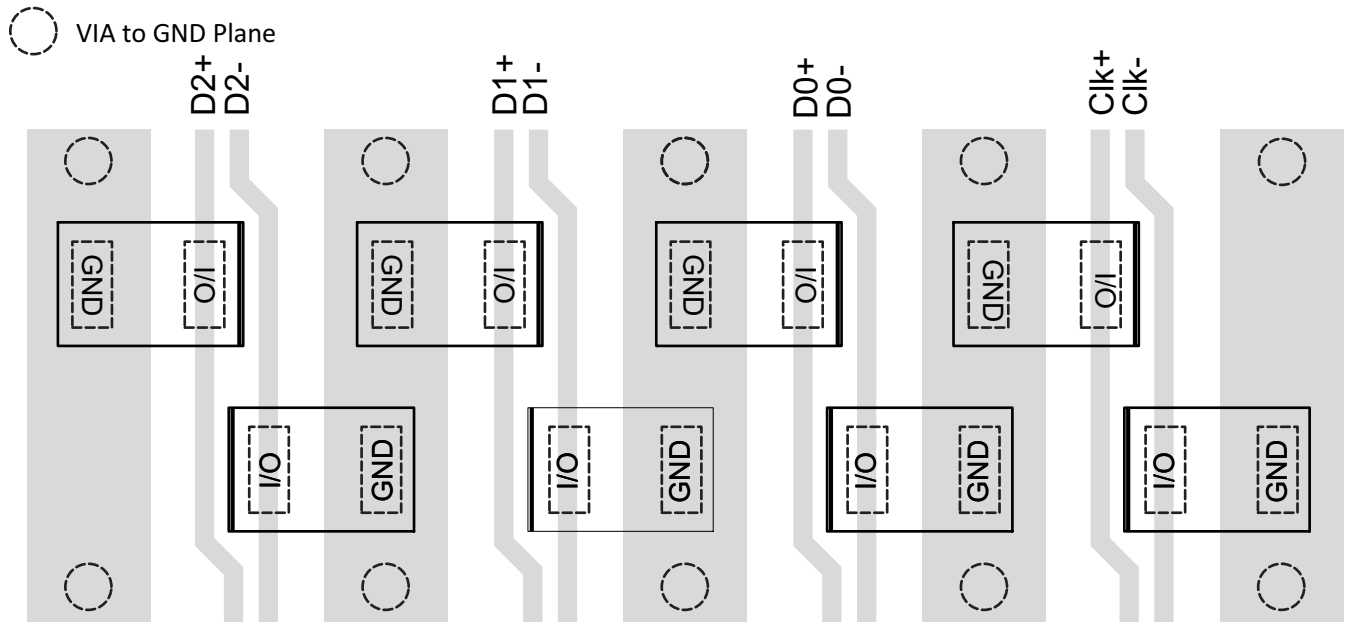

Figure 24. TPD4E05U06 Layout

**Layout Example (continued)**

**10.2.2 TPD1E05U06 Layout Example**

This application is typical of an HDMI 2.0 layout.



**Figure 25. TPD1E05U06 Layout**

## 11 Device and Documentation Support

### 11.1 Related Links

The table below lists quick access links. Categories include technical documents, support and community resources, tools and software, and quick access to sample or buy.

**Table 1. Related Links**

PARTS	PRODUCT FOLDER	SAMPLE & BUY	TECHNICAL DOCUMENTS	TOOLS & SOFTWARE	SUPPORT & COMMUNITY
TPD1E05U06	<a href="#">Click here</a>	<a href="#">Click here</a>	<a href="#">Click here</a>	<a href="#">Click here</a>	<a href="#">Click here</a>
TPD4E05U06	<a href="#">Click here</a>	<a href="#">Click here</a>	<a href="#">Click here</a>	<a href="#">Click here</a>	<a href="#">Click here</a>
TPD6E05U06	<a href="#">Click here</a>	<a href="#">Click here</a>	<a href="#">Click here</a>	<a href="#">Click here</a>	<a href="#">Click here</a>

### 11.2 Community Resources

The following links connect to TI community resources. Linked contents are provided "AS IS" by the respective contributors. They do not constitute TI specifications and do not necessarily reflect TI's views; see TI's [Terms of Use](#).

**TI E2E™ Online Community** *TI's Engineer-to-Engineer (E2E) Community*. Created to foster collaboration among engineers. At [e2e.ti.com](http://e2e.ti.com), you can ask questions, share knowledge, explore ideas and help solve problems with fellow engineers.

**Design Support** *TI's Design Support* Quickly find helpful E2E forums along with design support tools and contact information for technical support.

### 11.3 Trademarks

E2E is a trademark of Texas Instruments.

PCI-Express is a registered trademark of PCI-SIG .

V-by-One is a registered trademark of Thine Electronics, Inc.

All other trademarks are the property of their respective owners.

### 11.4 Electrostatic Discharge Caution



These devices have limited built-in ESD protection. The leads should be shorted together or the device placed in conductive foam during storage or handling to prevent electrostatic damage to the MOS gates.

### 11.5 Glossary

[SLYZ022](#) — *TI Glossary*.

This glossary lists and explains terms, acronyms, and definitions.

## 12 Mechanical, Packaging, and Orderable Information

The following pages include mechanical, packaging, and orderable information. This information is the most current data available for the designated devices. This data is subject to change without notice and revision of this document. For browser-based versions of this data sheet, refer to the left-hand navigation.

**PACKAGING INFORMATION**

Orderable Device	Status (1)	Package Type	Package Drawing	Pins	Package Qty	Eco Plan (2)	Lead/Ball Finish (6)	MSL Peak Temp (3)	Op Temp (°C)	Device Marking (4/5)	Samples
TPD1E05U06DPYR	ACTIVE	X1SON	DPY	2	10000	Green (RoHS & no Sb/Br)	CU NIPDAU	Level-1-260C-UNLIM	-40 to 125	(C1 ~ C6)	<a href="#">Samples</a>
TPD1E05U06DPYT	ACTIVE	X1SON	DPY	2	250	Green (RoHS & no Sb/Br)	CU NIPDAU	Level-1-260C-UNLIM	-40 to 125	(C1 ~ C6)	<a href="#">Samples</a>
TPD4E05U06DQAR	ACTIVE	USON	DQA	10	3000	Green (RoHS & no Sb/Br)	CU NIPDAU	Level-1-260C-UNLIM	-40 to 125	BR BRY	<a href="#">Samples</a>
TPD6E05U06RVZR	ACTIVE	USON	RVZ	14	3000	Green (RoHS & no Sb/Br)	CU NIPDAU	Level-1-260C-UNLIM	-40 to 125	(BVL ~ BVY)	<a href="#">Samples</a>

(1) The marketing status values are defined as follows:

**ACTIVE:** Product device recommended for new designs.

**LIFEBUY:** TI has announced that the device will be discontinued, and a lifetime-buy period is in effect.

**NRND:** Not recommended for new designs. Device is in production to support existing customers, but TI does not recommend using this part in a new design.

**PREVIEW:** Device has been announced but is not in production. Samples may or may not be available.

**OBSOLETE:** TI has discontinued the production of the device.

(2) Eco Plan - The planned eco-friendly classification: Pb-Free (RoHS), Pb-Free (RoHS Exempt), or Green (RoHS & no Sb/Br) - please check <http://www.ti.com/productcontent> for the latest availability information and additional product content details.

**TBD:** The Pb-Free/Green conversion plan has not been defined.

**Pb-Free (RoHS):** TI's terms "Lead-Free" or "Pb-Free" mean semiconductor products that are compatible with the current RoHS requirements for all 6 substances, including the requirement that lead not exceed 0.1% by weight in homogeneous materials. Where designed to be soldered at high temperatures, TI Pb-Free products are suitable for use in specified lead-free processes.

**Pb-Free (RoHS Exempt):** This component has a RoHS exemption for either 1) lead-based flip-chip solder bumps used between the die and package, or 2) lead-based die adhesive used between the die and leadframe. The component is otherwise considered Pb-Free (RoHS compatible) as defined above.

**Green (RoHS & no Sb/Br):** TI defines "Green" to mean Pb-Free (RoHS compatible), and free of Bromine (Br) and Antimony (Sb) based flame retardants (Br or Sb do not exceed 0.1% by weight in homogeneous material)

(3) MSL, Peak Temp. - The Moisture Sensitivity Level rating according to the JEDEC industry standard classifications, and peak solder temperature.

(4) There may be additional marking, which relates to the logo, the lot trace code information, or the environmental category on the device.

(5) Multiple Device Markings will be inside parentheses. Only one Device Marking contained in parentheses and separated by a "~" will appear on a device. If a line is indented then it is a continuation of the previous line and the two combined represent the entire Device Marking for that device.

(6) Lead/Ball Finish - Orderable Devices may have multiple material finish options. Finish options are separated by a vertical ruled line. Lead/Ball Finish values may wrap to two lines if the finish value exceeds the maximum column width.

**Important Information and Disclaimer:** The information provided on this page represents TI's knowledge and belief as of the date that it is provided. TI bases its knowledge and belief on information provided by third parties, and makes no representation or warranty as to the accuracy of such information. Efforts are underway to better integrate information from third parties. TI has taken and continues to take reasonable steps to provide representative and accurate information but may not have conducted destructive testing or chemical analysis on incoming materials and chemicals. TI and TI suppliers consider certain information to be proprietary, and thus CAS numbers and other limited information may not be available for release.

In no event shall TI's liability arising out of such information exceed the total purchase price of the TI part(s) at issue in this document sold by TI to Customer on an annual basis.

**OTHER QUALIFIED VERSIONS OF TPD4E05U06 :**

- Automotive: [TPD4E05U06-Q1](#)

NOTE: Qualified Version Definitions:

- Automotive - Q100 devices qualified for high-reliability automotive applications targeting zero defects

**TAPE AND REEL INFORMATION**

**QUADRANT ASSIGNMENTS FOR PIN 1 ORIENTATION IN TAPE**

\*All dimensions are nominal

Device	Package Type	Package Drawing	Pins	SPQ	Reel Diameter (mm)	Reel Width W1 (mm)	A0 (mm)	B0 (mm)	K0 (mm)	P1 (mm)	W (mm)	Pin1 Quadrant
TPD1E05U06DPYR	X1SON	DPY	2	10000	180.0	9.5	0.66	1.15	0.66	2.0	8.0	Q1
TPD1E05U06DPYT	X1SON	DPY	2	250	180.0	9.5	0.66	1.15	0.66	2.0	8.0	Q1
TPD6E05U06RVZR	USON	RVZ	14	3000	180.0	13.2	1.65	3.8	0.7	4.0	12.0	Q1

**TAPE AND REEL BOX DIMENSIONS**

\*All dimensions are nominal

Device	Package Type	Package Drawing	Pins	SPQ	Length (mm)	Width (mm)	Height (mm)
TPD1E05U06DPYR	X1SON	DPY	2	10000	184.0	184.0	19.0
TPD1E05U06DPYT	X1SON	DPY	2	250	184.0	184.0	19.0
TPD6E05U06RVZR	USON	RVZ	14	3000	184.0	184.0	19.0

RVZ (R-PUSON-N14)

PLASTIC SMALL OUTLINE NO-LEAD

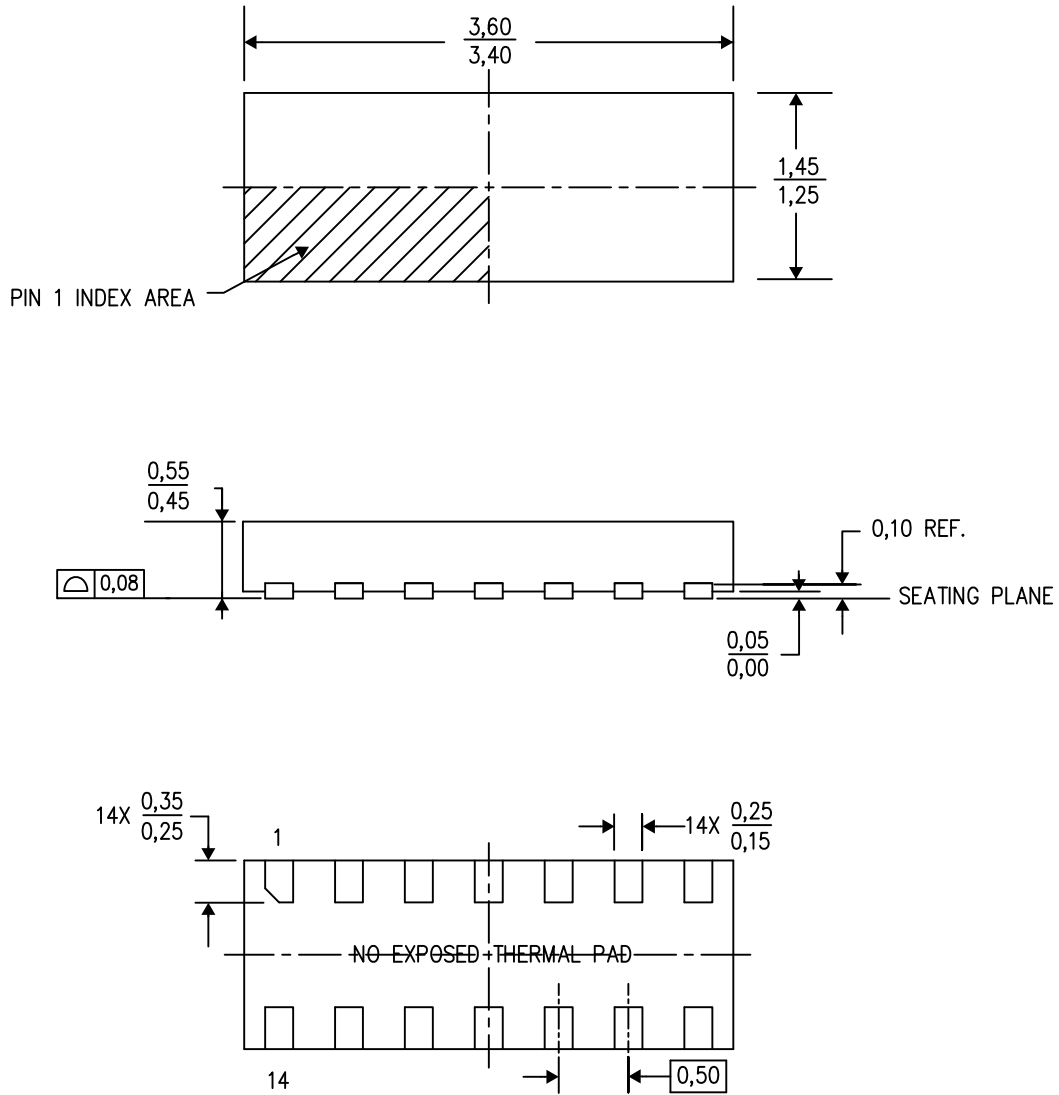

4218112/B 04/14

- NOTES:
- All linear dimensions are in millimeters. Dimensioning and tolerancing per ASME Y14.5M-1994.
  - This drawing is subject to change without notice.
  - QFN (Quad Flatpack No-Lead) package configuration.



DQA (R-PSON-N10)

PLASTIC SMALL OUTLINE NO-LEAD

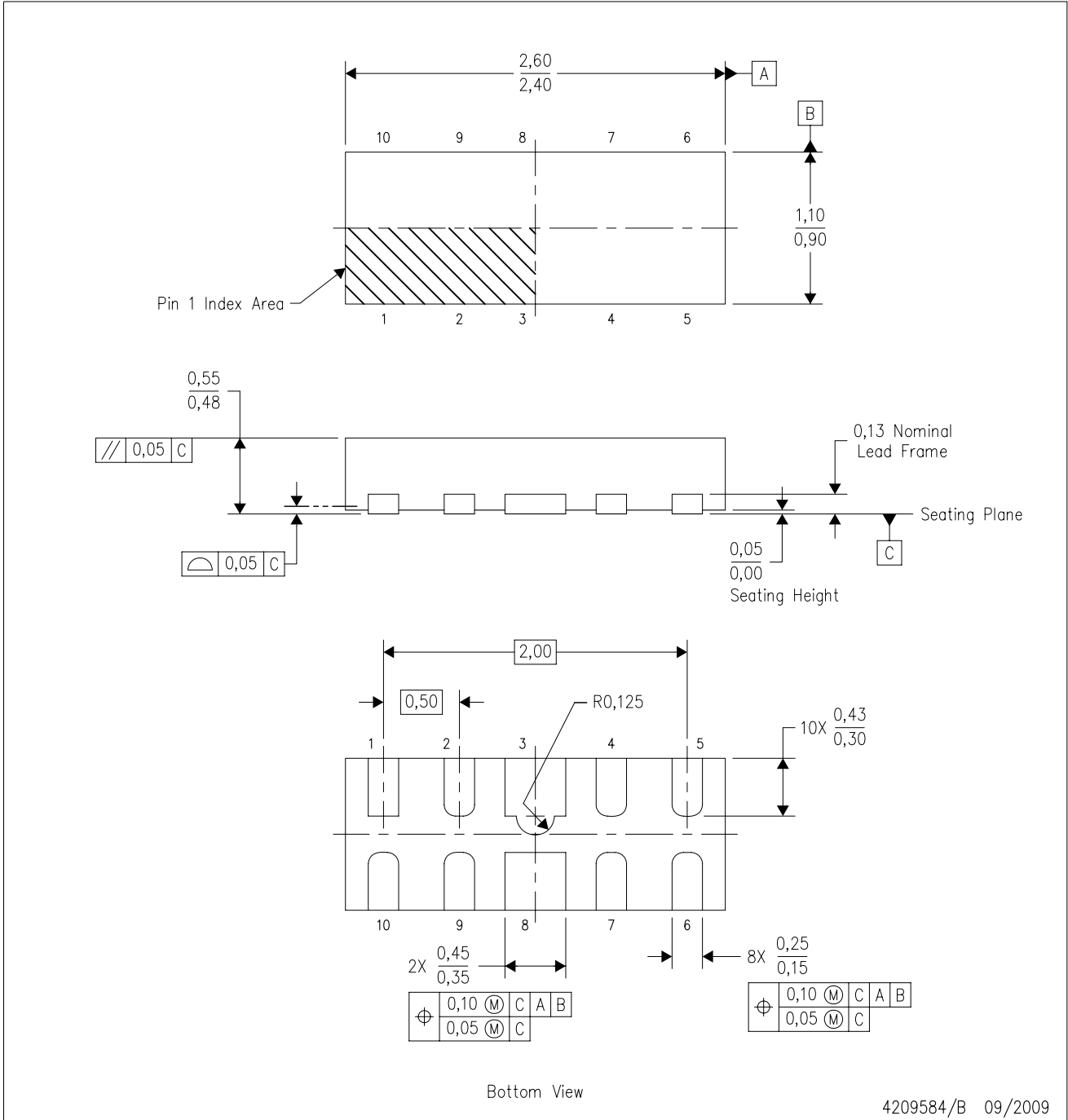

Bottom View

4209584/B 09/2009

- NOTES:
- A. All linear dimensions are in millimeters. Dimensioning and tolerancing per ASME Y14.5M-1994.
  - B. This drawing is subject to change without notice.
  - C. SON (Small Outline No-Lead) package configuration.

DQA (R-PUSON-N10)

PLASTIC SMALL OUTLINE NO-LEAD

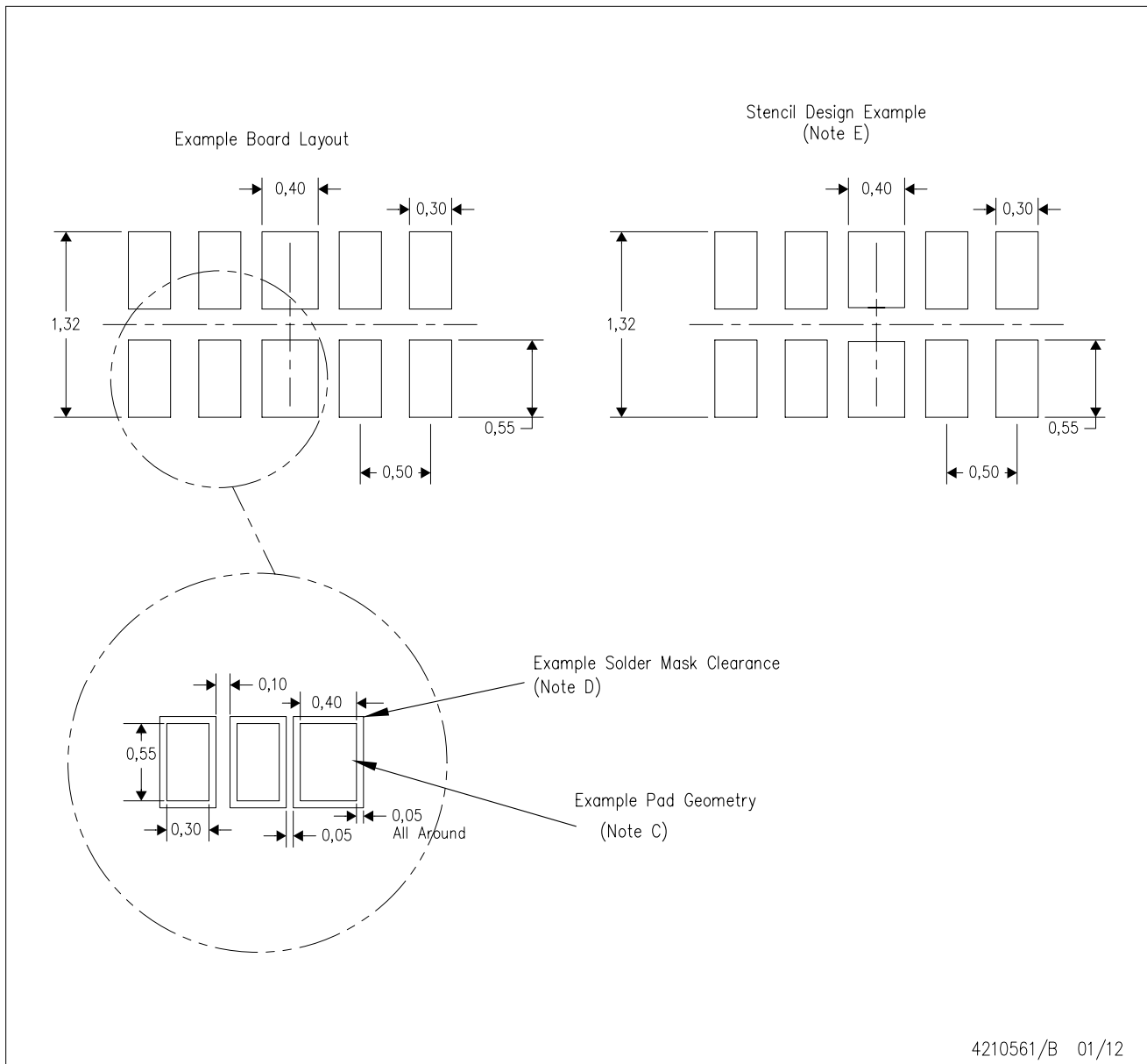

- NOTES:
- All linear dimensions are in millimeters.
  - This drawing is subject to change without notice.
  - Publication IPC-7351 is recommended for alternate designs.
  - Customers should contact their board fabrication site for minimum solder mask web tolerances between signal pads.
  - Maximum stencil thickness 0,127 mm (5 mils). All linear dimensions are in millimeters.
  - Laser cutting apertures with trapezoidal walls and also rounding corners will offer better paste release. Customers should contact their board assembly site for stencil design recommendations. Refer to IPC 7525 for stencil design considerations.
  - Side aperture dimensions over-print land for acceptable area ratio > 0.66. Customer may reduce side aperture dimensions if stencil manufacturing process allows for sufficient release at smaller opening.

DPY (R-PX1SON-N2)

PLASTIC SMALL OUTLINE NO-LEAD

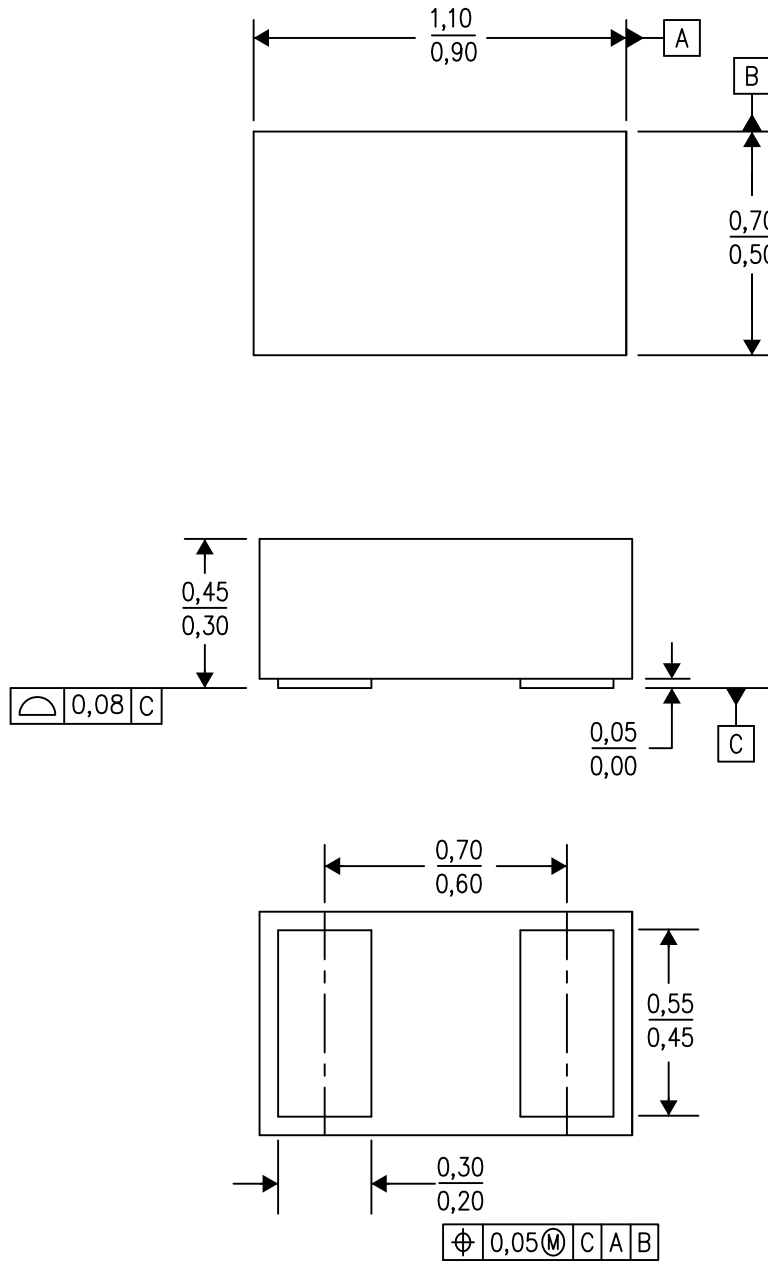

4211012/D 08/14

- NOTES:
- All linear dimensions are in millimeters. Dimensioning and tolerancing per ASME Y14.5-1994.
  - This drawing is subject to change without notice.
  - SON (Small Outline No-Lead) package configuration.

DPY (R-PX1SON-N2)

PLASTIC SMALL OUTLINE NO-LEAD

Example Board Layout

Example Stencil Design  
(Note E)

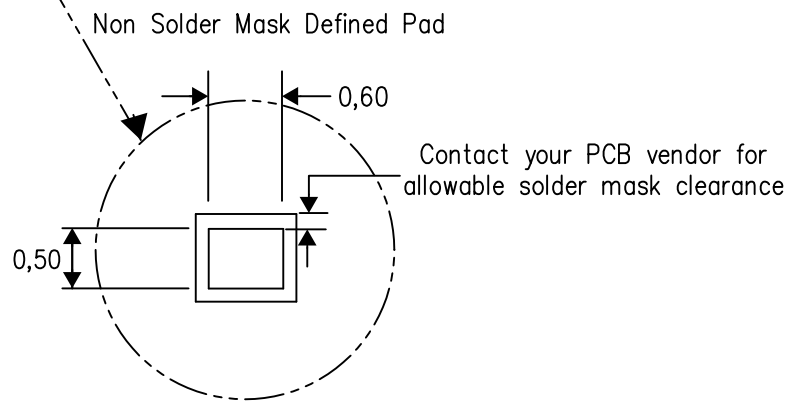
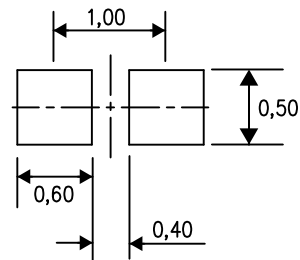
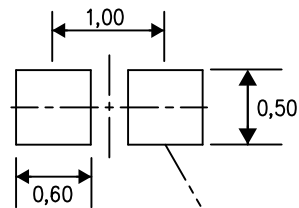

4215270/B 08/15

- NOTES:
- A. All linear dimensions are in millimeters.
  - B. This drawing is subject to change without notice.
  - C. Publication IPC-7351 is recommended for alternate designs.
  - D. Customers should contact their board fabrication site for minimum solder mask web tolerances between signal pads.
  - E. Maximum stencil thickness 0,127 mm (5 mils). All linear dimensions are in millimeters.
  - F. Laser cutting apertures with trapezoidal walls and also rounding corners will offer better paste release. Customers should contact their board assembly site for stencil design recommendations. Refer to IPC 7525 for stencil design considerations.
  - G. Side aperture dimensions over-print land for acceptable area ratio > 0.66. Customer may reduce side aperture dimensions if stencil manufacturing process allows for sufficient release at smaller opening.

## IMPORTANT NOTICE

Texas Instruments Incorporated and its subsidiaries (TI) reserve the right to make corrections, enhancements, improvements and other changes to its semiconductor products and services per JESD46, latest issue, and to discontinue any product or service per JESD48, latest issue. Buyers should obtain the latest relevant information before placing orders and should verify that such information is current and complete. All semiconductor products (also referred to herein as "components") are sold subject to TI's terms and conditions of sale supplied at the time of order acknowledgment.

TI warrants performance of its components to the specifications applicable at the time of sale, in accordance with the warranty in TI's terms and conditions of sale of semiconductor products. Testing and other quality control techniques are used to the extent TI deems necessary to support this warranty. Except where mandated by applicable law, testing of all parameters of each component is not necessarily performed.

TI assumes no liability for applications assistance or the design of Buyers' products. Buyers are responsible for their products and applications using TI components. To minimize the risks associated with Buyers' products and applications, Buyers should provide adequate design and operating safeguards.

TI does not warrant or represent that any license, either express or implied, is granted under any patent right, copyright, mask work right, or other intellectual property right relating to any combination, machine, or process in which TI components or services are used. Information published by TI regarding third-party products or services does not constitute a license to use such products or services or a warranty or endorsement thereof. Use of such information may require a license from a third party under the patents or other intellectual property of the third party, or a license from TI under the patents or other intellectual property of TI.

Reproduction of significant portions of TI information in TI data books or data sheets is permissible only if reproduction is without alteration and is accompanied by all associated warranties, conditions, limitations, and notices. TI is not responsible or liable for such altered documentation. Information of third parties may be subject to additional restrictions.

Resale of TI components or services with statements different from or beyond the parameters stated by TI for that component or service voids all express and any implied warranties for the associated TI component or service and is an unfair and deceptive business practice. TI is not responsible or liable for any such statements.

Buyer acknowledges and agrees that it is solely responsible for compliance with all legal, regulatory and safety-related requirements concerning its products, and any use of TI components in its applications, notwithstanding any applications-related information or support that may be provided by TI. Buyer represents and agrees that it has all the necessary expertise to create and implement safeguards which anticipate dangerous consequences of failures, monitor failures and their consequences, lessen the likelihood of failures that might cause harm and take appropriate remedial actions. Buyer will fully indemnify TI and its representatives against any damages arising out of the use of any TI components in safety-critical applications.

In some cases, TI components may be promoted specifically to facilitate safety-related applications. With such components, TI's goal is to help enable customers to design and create their own end-product solutions that meet applicable functional safety standards and requirements. Nonetheless, such components are subject to these terms.

No TI components are authorized for use in FDA Class III (or similar life-critical medical equipment) unless authorized officers of the parties have executed a special agreement specifically governing such use.

Only those TI components which TI has specifically designated as military grade or "enhanced plastic" are designed and intended for use in military/aerospace applications or environments. Buyer acknowledges and agrees that any military or aerospace use of TI components which have **not** been so designated is solely at the Buyer's risk, and that Buyer is solely responsible for compliance with all legal and regulatory requirements in connection with such use.

TI has specifically designated certain components as meeting ISO/TS16949 requirements, mainly for automotive use. In any case of use of non-designated products, TI will not be responsible for any failure to meet ISO/TS16949.

### Products

Audio	<a href="http://www.ti.com/audio">www.ti.com/audio</a>
Amplifiers	<a href="http://amplifier.ti.com">amplifier.ti.com</a>
Data Converters	<a href="http://dataconverter.ti.com">dataconverter.ti.com</a>
DLP® Products	<a href="http://www.dlp.com">www.dlp.com</a>
DSP	<a href="http://dsp.ti.com">dsp.ti.com</a>
Clocks and Timers	<a href="http://www.ti.com/clocks">www.ti.com/clocks</a>
Interface	<a href="http://interface.ti.com">interface.ti.com</a>
Logic	<a href="http://logic.ti.com">logic.ti.com</a>
Power Mgmt	<a href="http://power.ti.com">power.ti.com</a>
Microcontrollers	<a href="http://microcontroller.ti.com">microcontroller.ti.com</a>
RFID	<a href="http://www.ti-rfid.com">www.ti-rfid.com</a>
OMAP Applications Processors	<a href="http://www.ti.com/omap">www.ti.com/omap</a>
Wireless Connectivity	<a href="http://www.ti.com/wirelessconnectivity">www.ti.com/wirelessconnectivity</a>

### Applications

Automotive and Transportation	<a href="http://www.ti.com/automotive">www.ti.com/automotive</a>
Communications and Telecom	<a href="http://www.ti.com/communications">www.ti.com/communications</a>
Computers and Peripherals	<a href="http://www.ti.com/computers">www.ti.com/computers</a>
Consumer Electronics	<a href="http://www.ti.com/consumer-apps">www.ti.com/consumer-apps</a>
Energy and Lighting	<a href="http://www.ti.com/energy">www.ti.com/energy</a>
Industrial	<a href="http://www.ti.com/industrial">www.ti.com/industrial</a>
Medical	<a href="http://www.ti.com/medical">www.ti.com/medical</a>
Security	<a href="http://www.ti.com/security">www.ti.com/security</a>
Space, Avionics and Defense	<a href="http://www.ti.com/space-avionics-defense">www.ti.com/space-avionics-defense</a>
Video and Imaging	<a href="http://www.ti.com/video">www.ti.com/video</a>

### TI E2E Community

[e2e.ti.com](http://e2e.ti.com)