

TPD2E001 Low-Capacitance 2-Channel ESD-Protection for High-Speed Data Interfaces

1 Features

- IEC 61000-4-2 ESD Protection (Level 4)
 - ±8 kV Contact Discharge
 - ±15 kV Air-Gap Discharge
- IO Capacitance: 1.5 pF (Typ)
- Low Leakage Current: 1 nA (Max)
- Low Supply Current: 1 nA
- 0.9-V to 5.5-V Supply-Voltage Range
- Space-Saving DRL, DRY, and QFN Package Options
- Alternate 3, 4, 6-Channel options Available: TPD3E001, TPD4E001, TPD6E001

2 Applications

- USB 2.0
- Ethernet
- FireWire™
- LVDS
- SVGA Video Connections
- Glucose Meters
- Medical Imaging

3 Description

The TPD2E001 is a two-channel Transient Voltage Suppressor (TVS) based Electrostatic Discharge (ESD) protection diode array. The TPD2E001 is rated to dissipate ESD strikes at the maximum level specified in the IEC 61000-4-2 Level 4 international standard.

The DRS package (3.00 mm x 3.00 mm) is also available as a non-magnetic package for medical imaging applications.

See also [TPD2E2U06DRLR](#) which is p2p compatible to TPD2E001DRLR and offers higher IEC ESD Protection, lower clamping voltage, and eliminates the input capacitor requirement.

Device Information⁽¹⁾

PART NUMBER	PACKAGE	BODY SIZE (NOM)
TPD2E001	SOT (5)	1.60 mm x 1.20 mm
	WSON (6)	3.00 mm x 3.00 mm
	USON (6)	1.45 mm x 1.00 mm
	SOP (4)	2.90 mm x 1.30 mm

(1) For all available packages, see the orderable addendum at the end of the datasheet.

Application Schematic

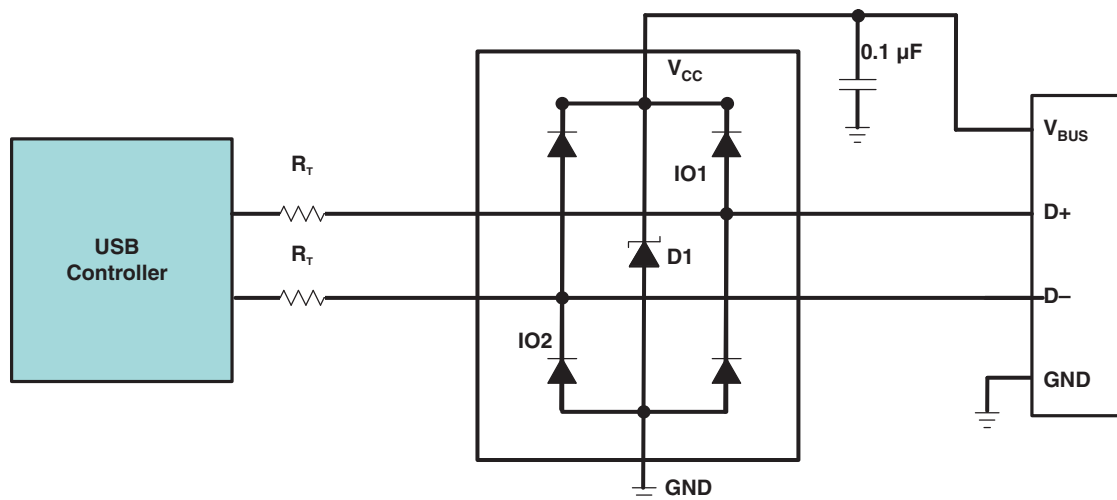

Table of Contents

<p>1 Features 1</p> <p>2 Applications 1</p> <p>3 Description 1</p> <p>4 Revision History..... 2</p> <p>5 Pin Configuration and Functions 3</p> <p>6 Specifications..... 3</p> <p> 6.1 Absolute Maximum Ratings 3</p> <p> 6.2 Handling Ratings 3</p> <p> 6.3 Recommended Operating Conditions 4</p> <p> 6.4 Thermal Information 4</p> <p> 6.5 Electrical Characteristics 4</p> <p> 6.6 Typical Characteristics 5</p> <p>7 Detailed Description 6</p> <p> 7.1 Overview 6</p> <p> 7.2 Functional Block Diagram 6</p>	<p> 7.3 Feature Description 6</p> <p> 7.4 Device Functional Modes 6</p> <p>8 Application and Implementation 7</p> <p> 8.1 Application Information 7</p> <p> 8.2 Typical Application 7</p> <p>9 Power Supply Recommendations 8</p> <p>10 Layout..... 8</p> <p> 10.1 Layout Guidelines 8</p> <p> 10.2 Layout Example 8</p> <p>11 Device and Documentation Support 9</p> <p> 11.1 Trademarks 9</p> <p> 11.2 Electrostatic Discharge Caution 9</p> <p> 11.3 Glossary 9</p> <p>12 Mechanical, Packaging, and Orderable Information 9</p>
--	---

4 Revision History

NOTE: Page numbers for previous revisions may differ from page numbers in the current version.

Changes from Revision G (November 2013) to Revision H	Page
<ul style="list-style-type: none"> • Added <i>Pin Configuration and Functions</i> section, <i>Handling Rating</i> table, <i>Feature Description</i> section, <i>Device Functional Modes</i>, <i>Application and Implementation</i> section, <i>Power Supply Recommendations</i> section, <i>Layout</i> section, <i>Device and Documentation Support</i> section, and <i>Mechanical, Packaging, and Orderable Information</i> section 1 	1
Changes from Revision F (February 2012) to Revision G	Page
<ul style="list-style-type: none"> • Updated document formatting. 1 • Updated Description. 1 • Removed Ordering Information table. 3 	3
Changes from Revision E (June 2008) to Revision F	Page
<ul style="list-style-type: none"> • Added Medical Imaging to Applications..... 1 • Added "The 3x3 mm DRS package is also available as a non-magnetic package for medical imaging application." to the description. 1 • Added 3 x 3 SON – DRS (Non-Magnetic) package to Ordering Information table. 3 	3

5 Pin Configuration and Functions

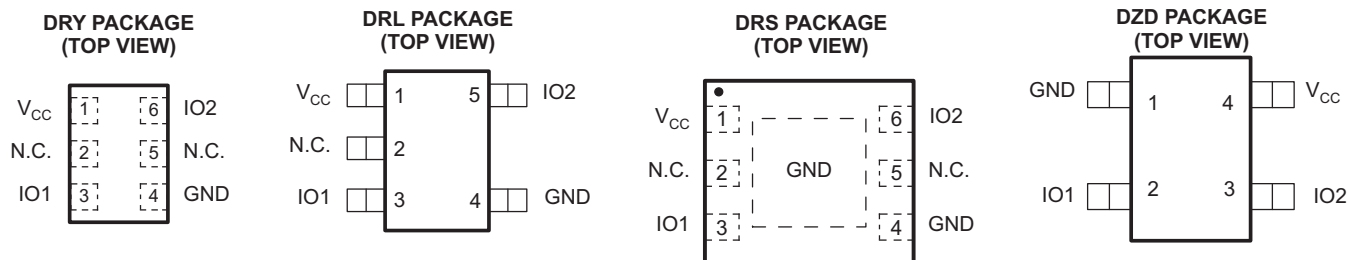

N.C. – Not internally connected

Pin Functions

DRY NO.	DRL NO.	DRS NO.	DZD NO.	NAME	FUNCTION
3, 6	3, 5	3, 6	2, 3	IOx	ESD-protected channel
4	4	4	1	GND	Ground
1	1	1	4	V _{CC}	Power-supply input. Bypass V _{CC} to GND with a 0.1- μ F ceramic capacitor.
2, 5	2	2, 5		N.C.	No connection. Not internally connected.
		EP		EP	Exposed pad. Connect to GND.

6 Specifications

6.1 Absolute Maximum Ratings⁽¹⁾

over operating free-air temperature range (unless otherwise noted)

		MIN	MAX	UNIT
V _{CC}	Power Pin Voltage	-0.3	7	V
V _{IO}	IO Pin Voltage	-0.3	V _{CC} + 0.3	V
T _J	Junction temperature		150	°C
	Bump temperature (soldering)		220	°C
		Infrared (15 s)	215	
	Lead temperature (soldering, 10 s)		300	°C

(1) Stresses beyond those listed under Absolute Maximum Ratings may cause permanent damage to the device. These are stress ratings only, and functional operation of the device at these or any other conditions beyond those indicated in the operational sections of the specifications is not implied. Exposure to absolute-maximum-rating conditions for extended periods may affect device reliability.

6.2 Handling Ratings

		MIN	MAX	UNIT	
T _{stg}	Storage temperature range	-65	150	°C	
V _(ESD)	Electrostatic discharge	Human body model (HBM), per ANSI/ESDA/JEDEC JS-001, all pins ⁽¹⁾	-15	15	kV
		Charged device model (CDM), per JEDEC specification JESD22-C101, all pins ⁽²⁾	-1	1	
		IEC 61000-4-2 Contact	-8	8	
		IEC 61000-4-2 Air-Gap Discharge	-15	15	

(1) JEDEC document JEP155 states that 500-V HBM allows safe manufacturing with a standard ESD control process.

(2) JEDEC document JEP157 states that 250-V CDM allows safe manufacturing with a standard ESD control process.

TPD2E001

SLLS684H – JULY 2006 – REVISED AUGUST 2014

6.3 Recommended Operating Conditions

over operating free-air temperature range (unless otherwise noted)

		MIN	MAX	UNIT
T_A Operating free-air Temperature Range		-40	85	°C
Operating Voltage	V_{CC} Pin	0.9	5.5	V
	IO1, IO2 Pins	0	V_{CC}	

6.4 Thermal Information

THERMAL METRIC ⁽¹⁾	TPD2E001				UNIT
	DRY	DRL	DRS	DZD	
	5 PINS	5 PINS	6 PINS	4 PINS	
$R_{\theta JA}$ Junction-to-ambient thermal resistance	374.2	257.6	91.9	213.7	°C/W
$R_{\theta JC(top)}$ Junction-to-case (top) thermal resistance	223.4	97.6	106.9	93.5	
$R_{\theta JB}$ Junction-to-board thermal resistance	227.8	74.2	64.8	56.8	
Ψ_{JT} Junction-to-top characterization parameter	52.9	7.5	10.2	4.2	
Ψ_{JB} Junction-to-board characterization parameter	224.8	73.7	64.9	56.4	
$R_{\theta JC(bot)}$ Junction-to-case (bottom) thermal resistance	87.5	N/A	29.9	N/A	

(1) For more information about traditional and new thermal metrics, see the *IC Package Thermal Metrics* application report, [SPRA953](#).

6.5 Electrical Characteristics

$V_{CC} = 5\text{ V} \pm 10\%$, $T_A = -40^\circ\text{C}$ to 85°C (unless otherwise noted)

PARAMETER	TEST CONDITIONS		MIN	TYP ⁽¹⁾	MAX	UNIT
V_{CC} Supply voltage			0.9		5.5	V
I_{CC} Supply current				1	100	nA
V_F Diode forward voltage	$I_F = 10\text{ mA}$		0.65		0.95	V
V_{BR} Breakdown Voltage	$I_{BR} = 10\text{ mA}$		11			V
V_C Channel clamp voltage ⁽²⁾	$T_A = 25^\circ\text{C}$, $\pm 15\text{-kV HBM}$, $I_F = 10\text{ A}$	Positive transients			$V_{CC} + 25$	V
		Negative transients			-25	
	$T_A = 25^\circ\text{C}$, $\pm 8\text{-kV Contact Discharge}$ (IEC 61000-4-2), $I_F = 24\text{ A}$	Positive transients			$V_{CC} + 60$	
		Negative transients			-60	
	$T_A = 25^\circ\text{C}$, $\pm 15\text{-kV Air-Gap Discharge}$ (IEC 61000-4-2), $I_F = 45\text{ A}$	Positive transients			$V_{CC} + 100$	
		Negative transients			-100	
$I_{i/o}$ Channel leakage current	$V_{i/o} = \text{GND to } V_{CC}$		-1		1	nA
$C_{i/o}$ Channel input capacitance	$V_{CC} = 5\text{ V}$, Bias of $V_{CC}/2$			1.5		pF

(1) Typical values are at $V_{CC} = 5\text{ V}$ and $T_A = 25^\circ\text{C}$

(2) Channel clamp voltage is not production tested.

6.6 Typical Characteristics

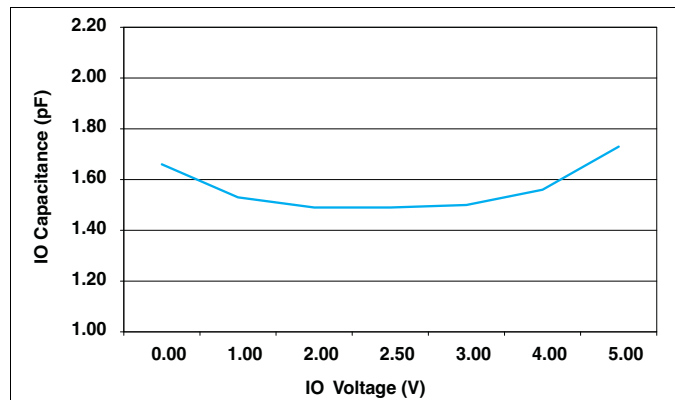

Figure 1. IO Capacitance vs IO Voltage ($V_{CC} = 5\text{ V}$)

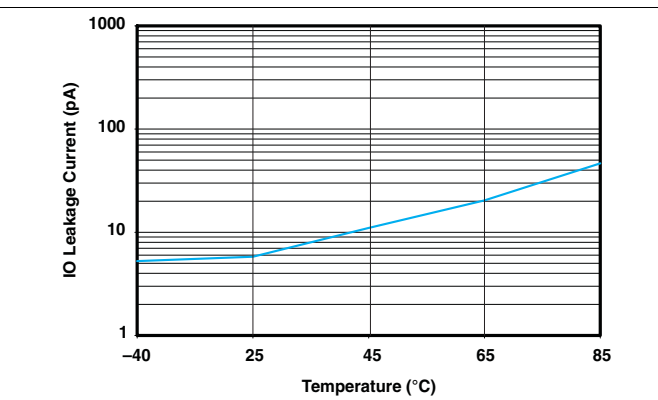

Figure 2. IO Leakage Current vs Temperature ($V_{CC} = 5\text{ V}$)

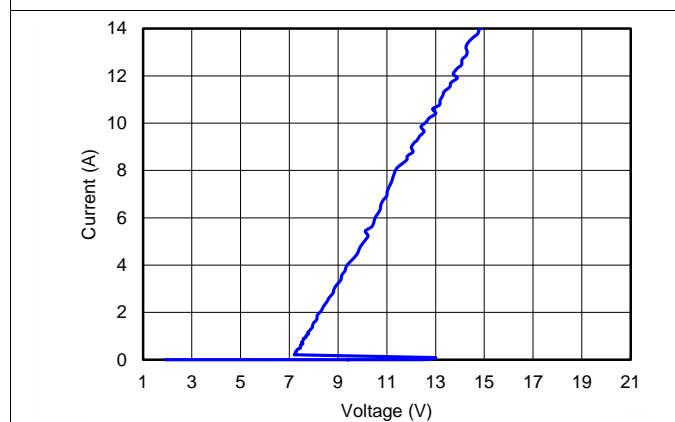

Figure 3. TLP IO to GND (DRS Package)

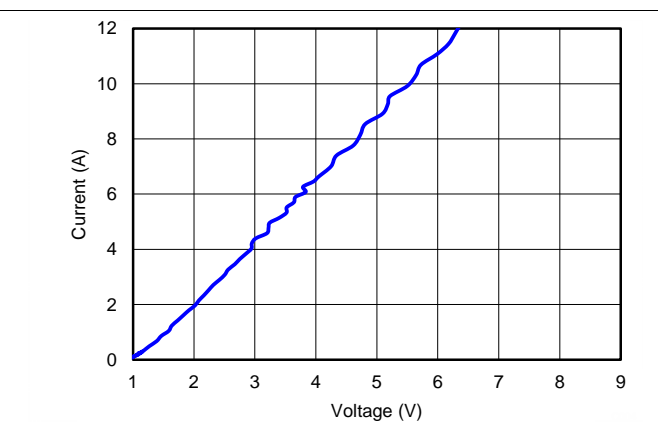

Figure 4. TLP GND to IO (DRS Package)

7 Detailed Description

7.1 Overview

The TPD2E001 is a two-channel Transient Voltage Suppressor (TVS) based Electrostatic Discharge (ESD) protection diode array. The TPD2E001 is rated to dissipate ESD strikes at the maximum level specified in the IEC 61000-4-2 Level 4 international standard.

7.2 Functional Block Diagram

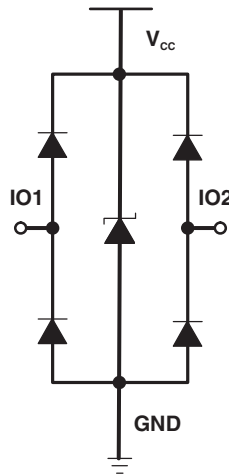

7.3 Feature Description

TPD2E001 is a uni-directional Electrostatic Discharge (ESD) protection device with low capacitance. The device is constructed with a central ESD clamp that features two hiding diodes per line to reduce the capacitive loading. This central ESD clamp is also connected to V_{CC} to provide protection for the V_{CC} line. Each IO line is rated to dissipate ESD strikes above the maximum level specified in the IEC 61000-4-2 level 4 international standard. The TPD2E001's low loading capacitance makes it ideal for protection high-speed signal terminals.

7.4 Device Functional Modes

TPD2E001 is a passive integrated circuit that activates whenever voltages above V_{BR} or below the lower diodes $V_{forward}$ ($-0.6V$) are present upon the circuit being protected. During ESD events, voltages as high as ± 15 kV can be directed to ground and V_{CC} via the internal diode network. Once the voltages on the protected lines fall below the trigger voltage of the TPD2E001 (usually within 10's of nano-seconds) the device reverts back to a high impedance state.

8 Application and Implementation

8.1 Application Information

TPD2E001 is a diode array type Transient Voltage Suppressor (TVS) which is typically used to provide a path to ground for dissipating ESD events on hi-speed signal lines between a human interface connector and a system. As the current from ESD passes through the TVS, only a small voltage drop is present across the diode. This is the voltage presented to the protected IC. The low R_{DYN} of the triggered TVS holds this voltage, V_{CLAMP} , to a tolerable level to the protected IC.

8.2 Typical Application

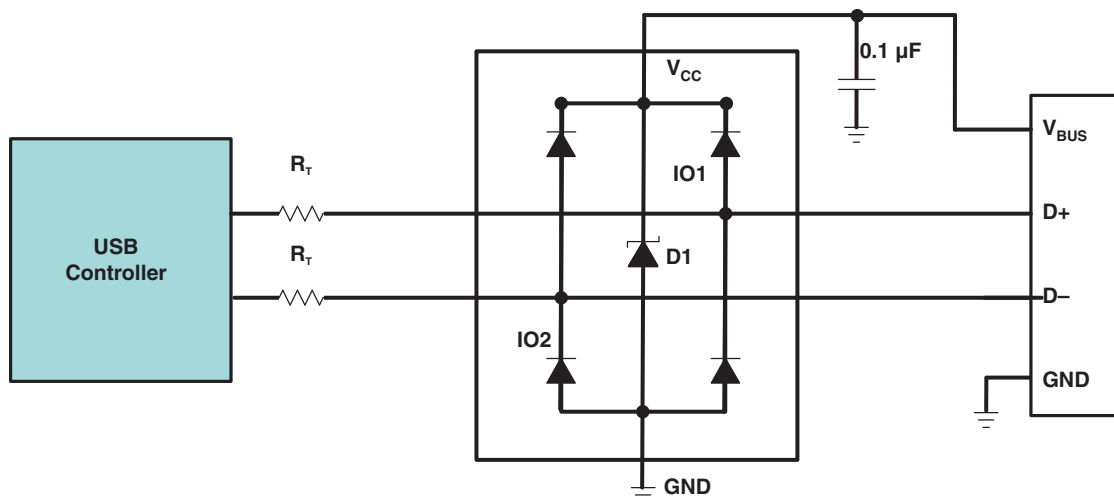

Figure 5. Typical USB Application Diagram

8.2.1 Design Requirements

For this design example, a single TPD2E001 is used to protect all pins of a USB 2.0 connector.

Given the USB application, the following parameters are known.

DESIGN PARAMETER	VALUE
Signal range on IO1, and IO2	0 V to 5 V
Signal voltage range on V_{CC}	0 V to 5 V
Operating Frequency	240 MHz

8.2.2 Detailed Design Procedure

To begin the design process, some parameters must be decided upon; the designer needs to know the following:

- Signal voltage range on all the protected lines
- Operating frequency

The V_{CC} pin can be connected in two different ways:

1. If the V_{CC} pin is connected to the system power supply, the TPD2E001 works as a transient suppressor for any signal swing above $V_{CC} + V_F$. A 0.1- μ F capacitor on the device V_{CC} pin is recommended for ESD bypass.
2. If the V_{CC} pin is not connected to the system power supply, the TPD2E001 can tolerate higher signal swing in the range up to 10 V. Please note that a 0.1- μ F capacitor is still recommended at the V_{CC} pin for ESD bypass.

8.2.2.1 Signal Range on IO1 and IO2 and V_{CC} pins

The TPD2E001 has 2 IO pins which support 0 to either 10 V or $V_{CC} + V_{forward}$ (depending on if the V_{CC} pin is connected to a V_{CC} line or has a 0.1 μ F capacitor to ground).

9 Power Supply Recommendations

This device is a passive ESD protection device and there is no need to power it. Care should be taken to make sure that the maximum voltage specifications for each line are not violated.

10 Layout

10.1 Layout Guidelines

- The optimum placement is as close to the connector as possible.
 - EMI during an ESD event can couple from the trace being struck to other nearby unprotected traces, resulting in early system failures.
 - The PCB designer needs to minimize the possibility of EMI coupling by keeping any unprotected traces away from the protected traces which are between the TVS and the connector.
- Route the protected traces as straight as possible.
- Eliminate any sharp corners on the protected traces between the TVS and the connector by using rounded corners with the largest radii possible.
 - Electric fields tend to build up on corners, increasing EMI coupling.

10.2 Layout Example

This application is typical of a differential data pair application, such as a USB 2.0.

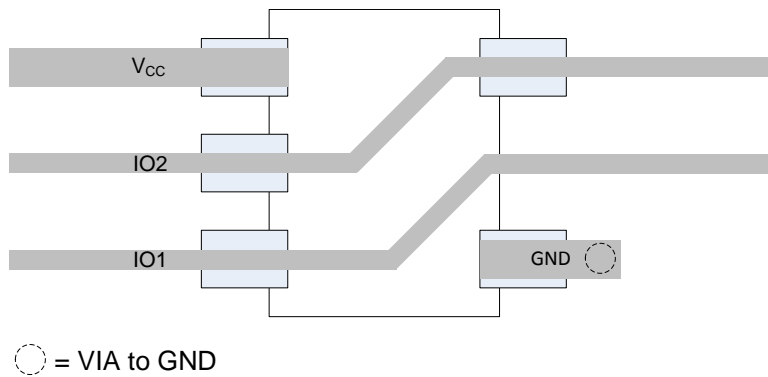

Figure 6. Routing with DRL Package

11 Device and Documentation Support

11.1 Trademarks

FireWire is a trademark of Apple Computer, Inc.
All other trademarks are the property of their respective owners.

11.2 Electrostatic Discharge Caution



These devices have limited built-in ESD protection. The leads should be shorted together or the device placed in conductive foam during storage or handling to prevent electrostatic damage to the MOS gates.

11.3 Glossary

[SLYZ022](#) — *TI Glossary*.

This glossary lists and explains terms, acronyms, and definitions.

12 Mechanical, Packaging, and Orderable Information

The following pages include mechanical, packaging, and orderable information. This information is the most current data available for the designated devices. This data is subject to change without notice and revision of this document. For browser-based versions of this data sheet, refer to the left-hand navigation.

PACKAGING INFORMATION

Orderable Device	Status (1)	Package Type	Package Drawing	Pins	Package Qty	Eco Plan (2)	Lead/Ball Finish (6)	MSL Peak Temp (3)	Op Temp (°C)	Device Marking (4/5)	Samples
TPD2E001DRLR	ACTIVE	SOT	DRL	5	4000	Green (RoHS & no Sb/Br)	CU NIPDAU CU SN	Level-1-260C-UNLIM	-40 to 85	(2AR ~ 2AZ) 2AH	Samples
TPD2E001DRLRG4	ACTIVE	SOT	DRL	5	4000	Green (RoHS & no Sb/Br)	CU SN	Level-1-260C-UNLIM	-40 to 85	(2AR ~ 2AZ) 2AH	Samples
TPD2E001DRSR	ACTIVE	SON	DRS	6	1000	Green (RoHS & no Sb/Br)	CU NIPDAU	Level-2-260C-1 YEAR	-40 to 85	ZWK	Samples
TPD2E001DRST-NM	ACTIVE	SON	DRS	6	250	Green (RoHS & no Sb/Br)	CU SN	Level-2-260C-1 YEAR	-40 to 85	ZWKNM	Samples
TPD2E001DRYR	ACTIVE	SON	DRY	6	5000	Green (RoHS & no Sb/Br)	CU NIPDAU	Level-1-260C-UNLIM	-40 to 85	2A	Samples
TPD2E001DRYRG4	ACTIVE	SON	DRY	6	5000	Green (RoHS & no Sb/Br)	CU NIPDAU	Level-1-260C-UNLIM	-40 to 85	2A	Samples
TPD2E001DZDR	ACTIVE	SOP	DZD	4	3000	Green (RoHS & no Sb/Br)	CU NIPDAU	Level-1-260C-UNLIM	-40 to 85	NFGO	Samples

(1) The marketing status values are defined as follows:

ACTIVE: Product device recommended for new designs.

LIFEBUY: TI has announced that the device will be discontinued, and a lifetime-buy period is in effect.

NRND: Not recommended for new designs. Device is in production to support existing customers, but TI does not recommend using this part in a new design.

PREVIEW: Device has been announced but is not in production. Samples may or may not be available.

OBSELETE: TI has discontinued the production of the device.

(2) Eco Plan - The planned eco-friendly classification: Pb-Free (RoHS), Pb-Free (RoHS Exempt), or Green (RoHS & no Sb/Br) - please check <http://www.ti.com/productcontent> for the latest availability information and additional product content details.

TBD: The Pb-Free/Green conversion plan has not been defined.

Pb-Free (RoHS): TI's terms "Lead-Free" or "Pb-Free" mean semiconductor products that are compatible with the current RoHS requirements for all 6 substances, including the requirement that lead not exceed 0.1% by weight in homogeneous materials. Where designed to be soldered at high temperatures, TI Pb-Free products are suitable for use in specified lead-free processes.

Pb-Free (RoHS Exempt): This component has a RoHS exemption for either 1) lead-based flip-chip solder bumps used between the die and package, or 2) lead-based die adhesive used between the die and leadframe. The component is otherwise considered Pb-Free (RoHS compatible) as defined above.

Green (RoHS & no Sb/Br): TI defines "Green" to mean Pb-Free (RoHS compatible), and free of Bromine (Br) and Antimony (Sb) based flame retardants (Br or Sb do not exceed 0.1% by weight in homogeneous material)

(3) MSL, Peak Temp. - The Moisture Sensitivity Level rating according to the JEDEC industry standard classifications, and peak solder temperature.

(4) There may be additional marking, which relates to the logo, the lot trace code information, or the environmental category on the device.

⁽⁵⁾ Multiple Device Markings will be inside parentheses. Only one Device Marking contained in parentheses and separated by a "-" will appear on a device. If a line is indented then it is a continuation of the previous line and the two combined represent the entire Device Marking for that device.

⁽⁶⁾ Lead/Ball Finish - Orderable Devices may have multiple material finish options. Finish options are separated by a vertical ruled line. Lead/Ball Finish values may wrap to two lines if the finish value exceeds the maximum column width.

Important Information and Disclaimer:The information provided on this page represents TI's knowledge and belief as of the date that it is provided. TI bases its knowledge and belief on information provided by third parties, and makes no representation or warranty as to the accuracy of such information. Efforts are underway to better integrate information from third parties. TI has taken and continues to take reasonable steps to provide representative and accurate information but may not have conducted destructive testing or chemical analysis on incoming materials and chemicals. TI and TI suppliers consider certain information to be proprietary, and thus CAS numbers and other limited information may not be available for release.

In no event shall TI's liability arising out of such information exceed the total purchase price of the TI part(s) at issue in this document sold by TI to Customer on an annual basis.

OTHER QUALIFIED VERSIONS OF TPD2E001 :

- Automotive: [TPD2E001-Q1](#)

NOTE: Qualified Version Definitions:

- Automotive - Q100 devices qualified for high-reliability automotive applications targeting zero defects

TAPE AND REEL INFORMATION

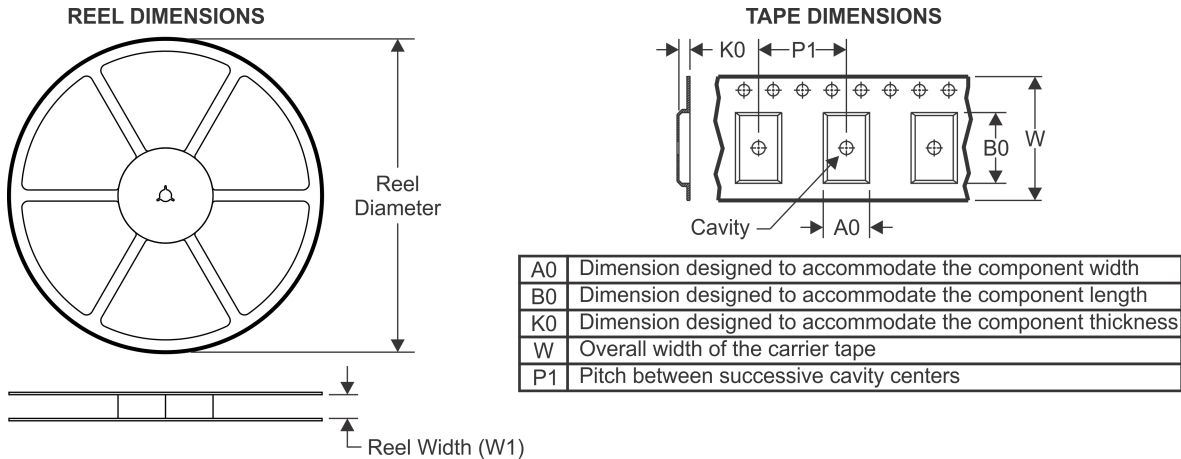

QUADRANT ASSIGNMENTS FOR PIN 1 ORIENTATION IN TAPE

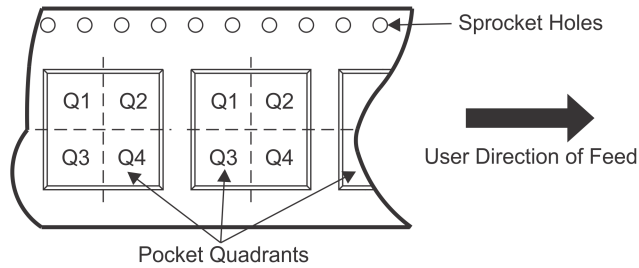

*All dimensions are nominal

Device	Package Type	Package Drawing	Pins	SPQ	Reel Diameter (mm)	Reel Width W1 (mm)	A0 (mm)	B0 (mm)	K0 (mm)	P1 (mm)	W (mm)	Pin1 Quadrant
TPD2E001DRLR	SOT	DRL	5	4000	180.0	8.4	1.98	1.78	0.69	4.0	8.0	Q3
TPD2E001DRLR	SOT	DRL	5	4000	180.0	9.0	1.75	1.75	0.9	4.0	8.0	Q3
TPD2E001DRSR	SON	DRS	6	1000	330.0	12.4	3.3	3.3	1.1	8.0	12.0	Q2
TPD2E001DRYR	SON	DRY	6	5000	179.0	8.4	1.2	1.65	0.7	4.0	8.0	Q1
TPD2E001DZDR	SOP	DZD	4	3000	179.0	8.4	3.15	2.6	1.2	4.0	8.0	Q3

TAPE AND REEL BOX DIMENSIONS

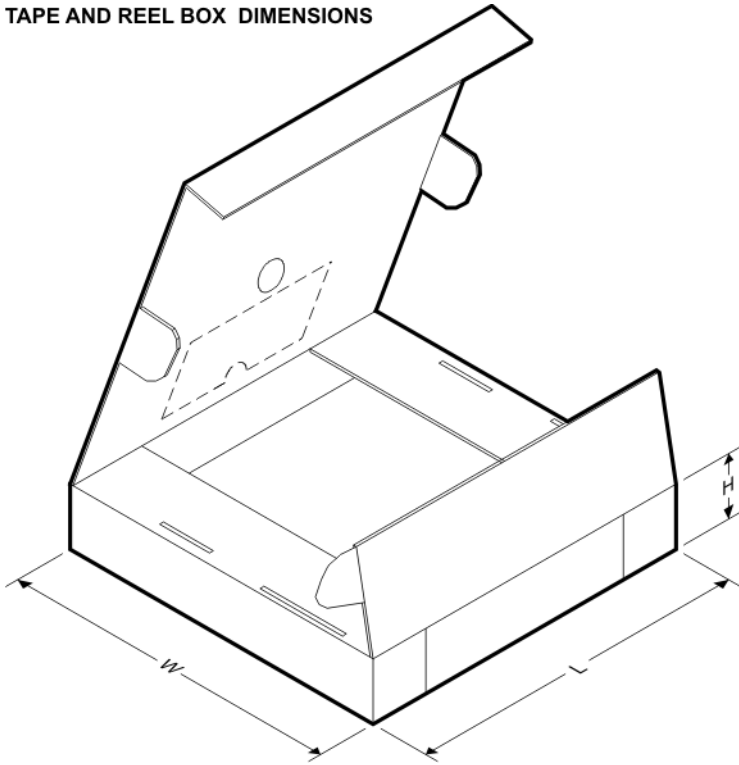

*All dimensions are nominal

Device	Package Type	Package Drawing	Pins	SPQ	Length (mm)	Width (mm)	Height (mm)
TPD2E001DRLR	SOT	DRL	5	4000	202.0	201.0	28.0
TPD2E001DRLR	SOT	DRL	5	4000	182.0	182.0	20.0
TPD2E001DRSR	SON	DRS	6	1000	367.0	367.0	35.0
TPD2E001DRYR	SON	DRY	6	5000	203.0	203.0	35.0
TPD2E001DZDR	SOP	DZD	4	3000	203.0	203.0	35.0

DRL (R-PDSO-N5)

PLASTIC SMALL OUTLINE

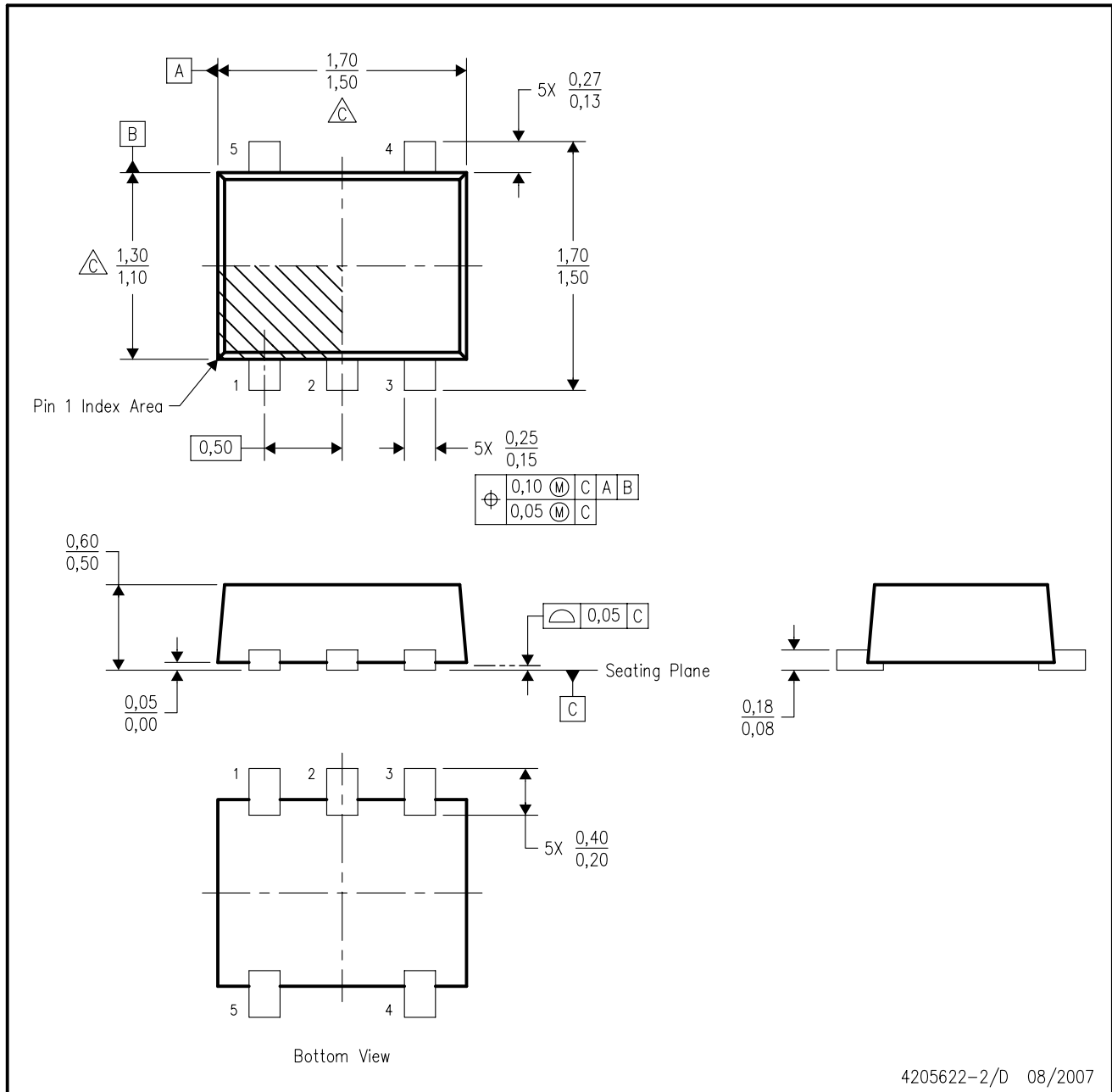

- NOTES:
- A. All linear dimensions are in millimeters. Dimensioning and tolerancing per ASME Y14.5M-1994.
 - B. This drawing is subject to change without notice.
 - C. Body dimensions do not include mold flash, interlead flash, protrusions, or gate burrs. Mold flash, interlead flash, protrusions, or gate burrs shall not exceed 0,15 per end or side.
 - D. JEDEC package registration is pending.

DRL (R-PDSO-N5)

PLASTIC SMALL OUTLINE

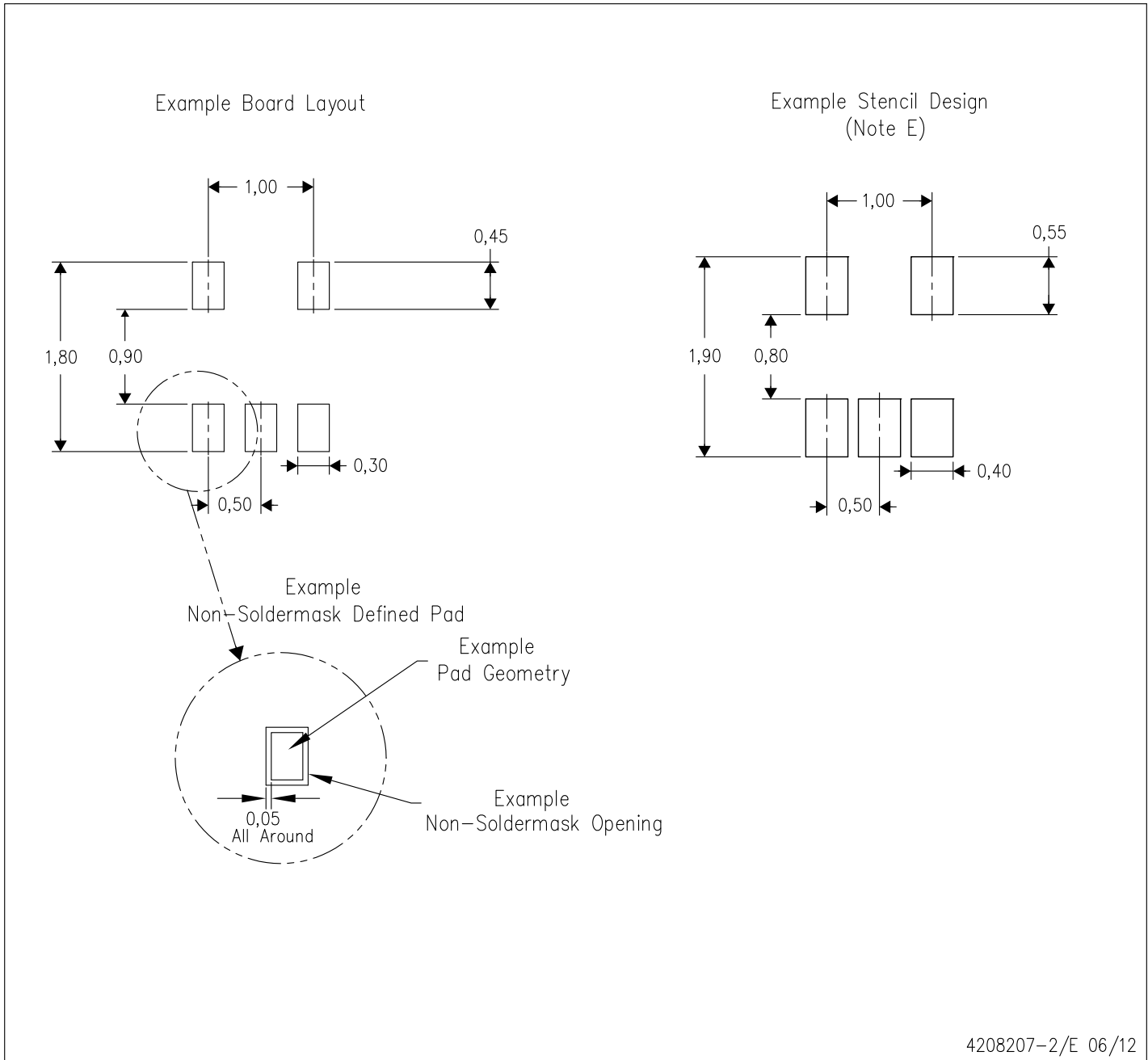

- NOTES:
- A. All linear dimensions are in millimeters.
 - B. This drawing is subject to change without notice.
 - C. Publication IPC-7351 is recommended for alternate designs.
 - D. Customers should contact their board fabrication site for minimum solder mask web tolerances between signal pads.
 - E. Maximum stencil thickness 0,127 mm (5 mils). All linear dimensions are in millimeters.
 - F. Laser cutting apertures with trapezoidal walls and also rounding corners will offer better paste release. Customers should contact their board assembly site for stencil design recommendations. Refer to IPC 7525 for stencil design considerations.
 - G. Side aperture dimensions over-print land for acceptable area ratio > 0.66. Customer may reduce side aperture dimensions if stencil manufacturing process allows for sufficient release at smaller opening.

DRS (S-PWSON-N6)

PLASTIC SMALL OUTLINE NO-LEAD

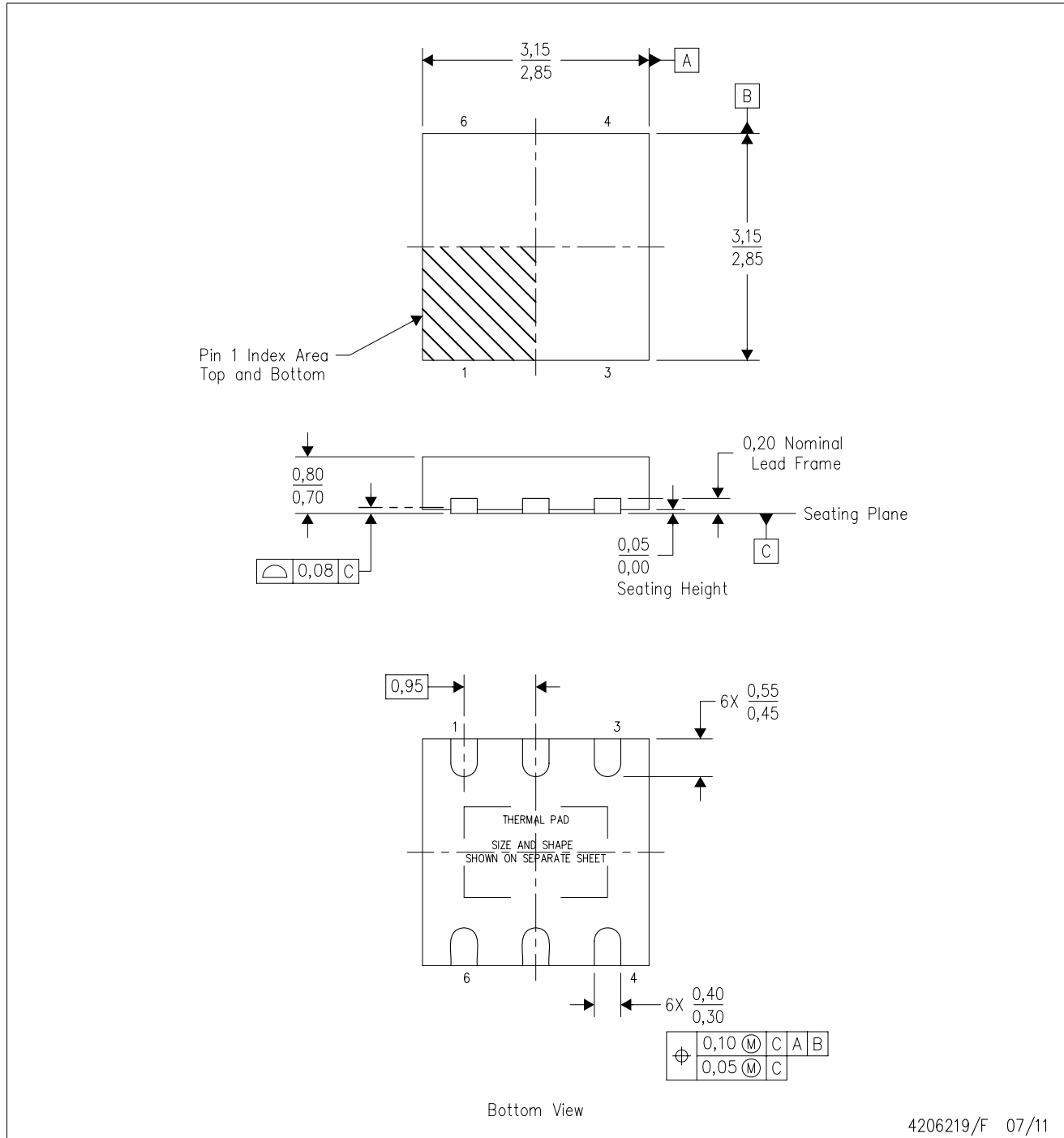

- NOTES:
- All linear dimensions are in millimeters. Dimensioning and tolerancing per ASME Y14.5M-1994.
 - This drawing is subject to change without notice.
 - SON (Small Outline No-Lead) package configuration.
 - The package thermal pad must be soldered to the board for thermal and mechanical performance.
 - See the additional figure in the Product Data Sheet for details regarding the exposed thermal pad features and dimensions.

THERMAL PAD MECHANICAL DATA

DRS (S-PWSON-N6)

PLASTIC SMALL OUTLINE NO-LEAD

THERMAL INFORMATION

This package incorporates an exposed thermal pad that is designed to be attached directly to an external heatsink. The thermal pad must be soldered directly to the printed circuit board (PCB). After soldering, the PCB can be used as a heatsink. In addition, through the use of thermal vias, the thermal pad can be attached directly to the appropriate copper plane shown in the electrical schematic for the device, or alternatively, can be attached to a special heatsink structure designed into the PCB. This design optimizes the heat transfer from the integrated circuit (IC).

For information on the Quad Flatpack No-Lead (QFN) package and its advantages, refer to Application Report, QFN/SON PCB Attachment, Texas Instruments Literature No. SLUA271. This document is available at www.ti.com.

The exposed thermal pad dimensions for this package are shown in the following illustration.

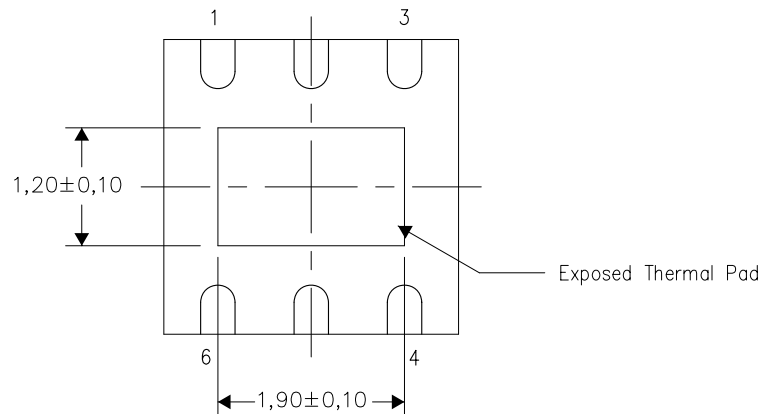

Bottom View

Exposed Thermal Pad Dimensions

4207663/E 07/11

NOTE: All linear dimensions are in millimeters

DRS (S-PWSON-N6)

PLASTIC SMALL OUTLINE NO-LEAD

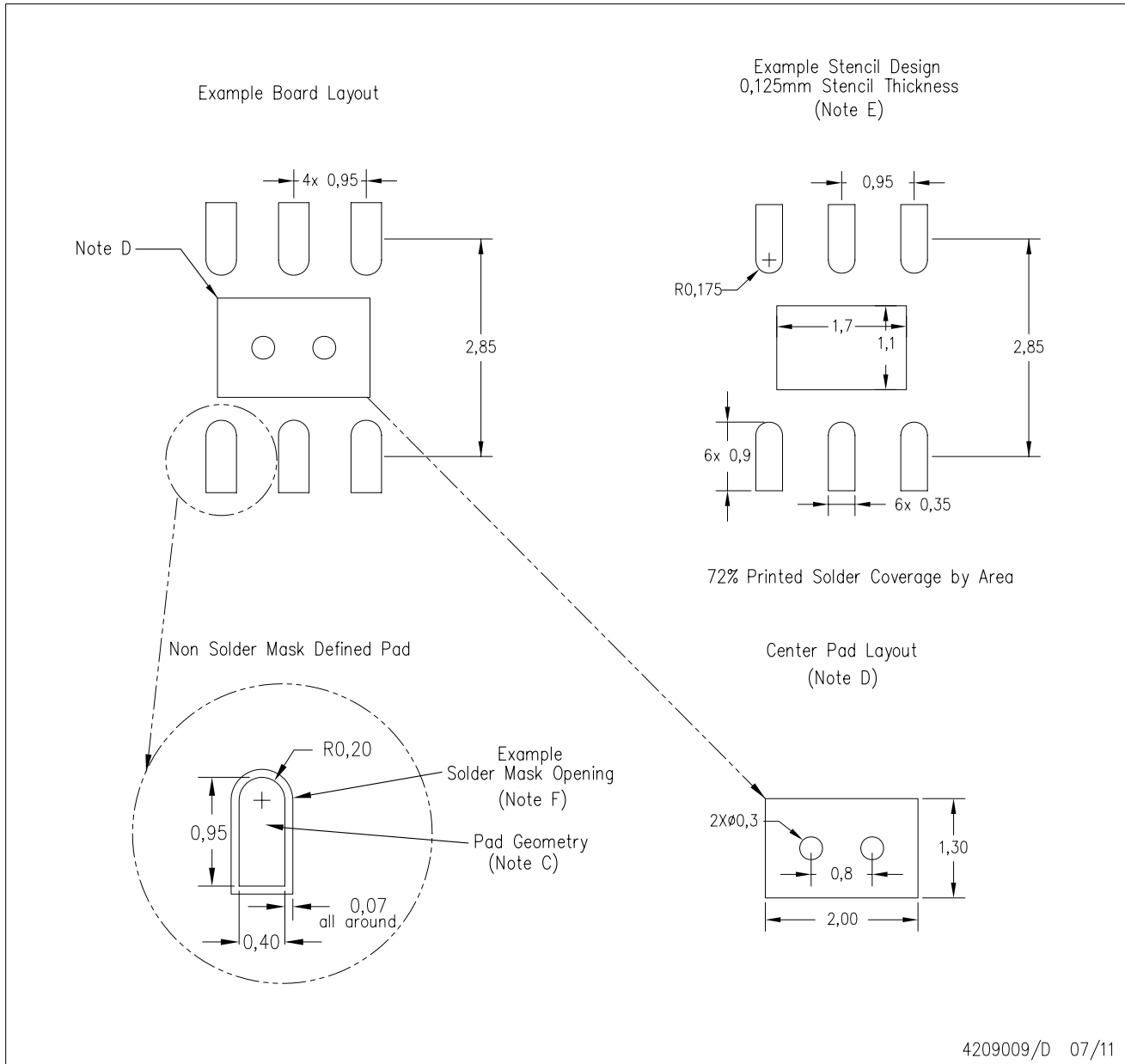

- NOTES:
- All linear dimensions are in millimeters.
 - This drawing is subject to change without notice.
 - Publication IPC-7351 is recommended for alternate designs.
 - This package is designed to be soldered to a thermal pad on the board. Refer to Application Note, QFN/SON PCB Attachment, Texas Instruments Literature No. SLUA271, and also the Product Data Sheets for specific thermal information, via requirements, and recommended board layout. These documents are available at www.ti.com <<http://www.ti.com>>.
 - Laser cutting apertures with trapezoidal walls and also rounding corners will offer better paste release. Customers should contact their board assembly site for stencil design recommendations. Refer to IPC 7525 for stencil design considerations.
 - Customers should contact their board fabrication site for solder mask tolerances.

DZD (R-PDSO-G4)

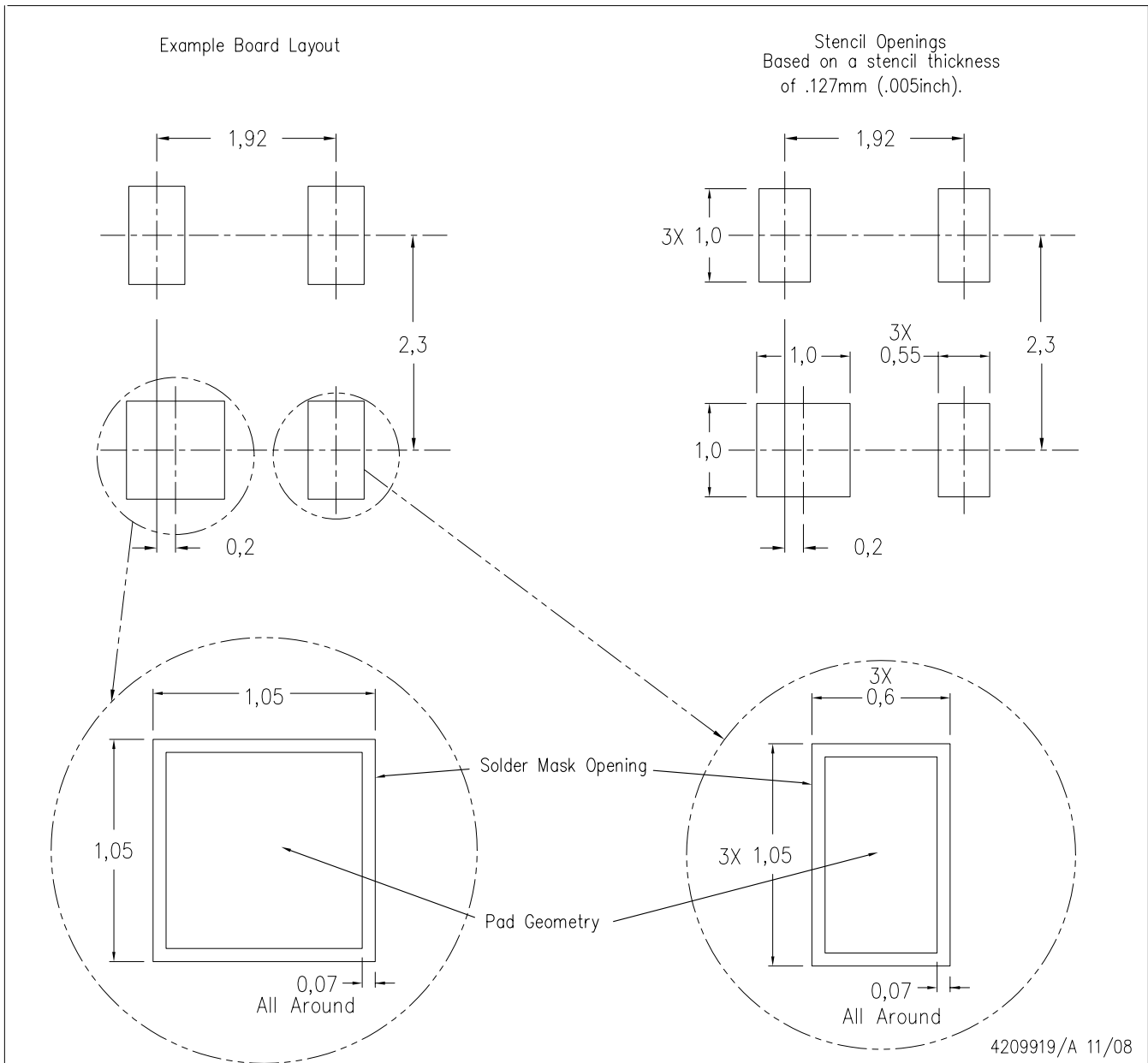

- NOTES:
- A. All linear dimensions are in millimeters.
 - B. This drawing is subject to change without notice.
 - C. Customers should place a note on the circuit board fabrication drawing not to alter the center solder mask defined pad.
 - D. Publication IPC-7351 is recommended for alternate designs.
 - E. Laser cutting apertures with trapezoidal walls and also rounding corners will offer better paste release. Customers should contact their board assembly site for stencil design recommendations. Refer to IPC-7525 for other stencil recommendations.

DZD (R-PDSO-G4)

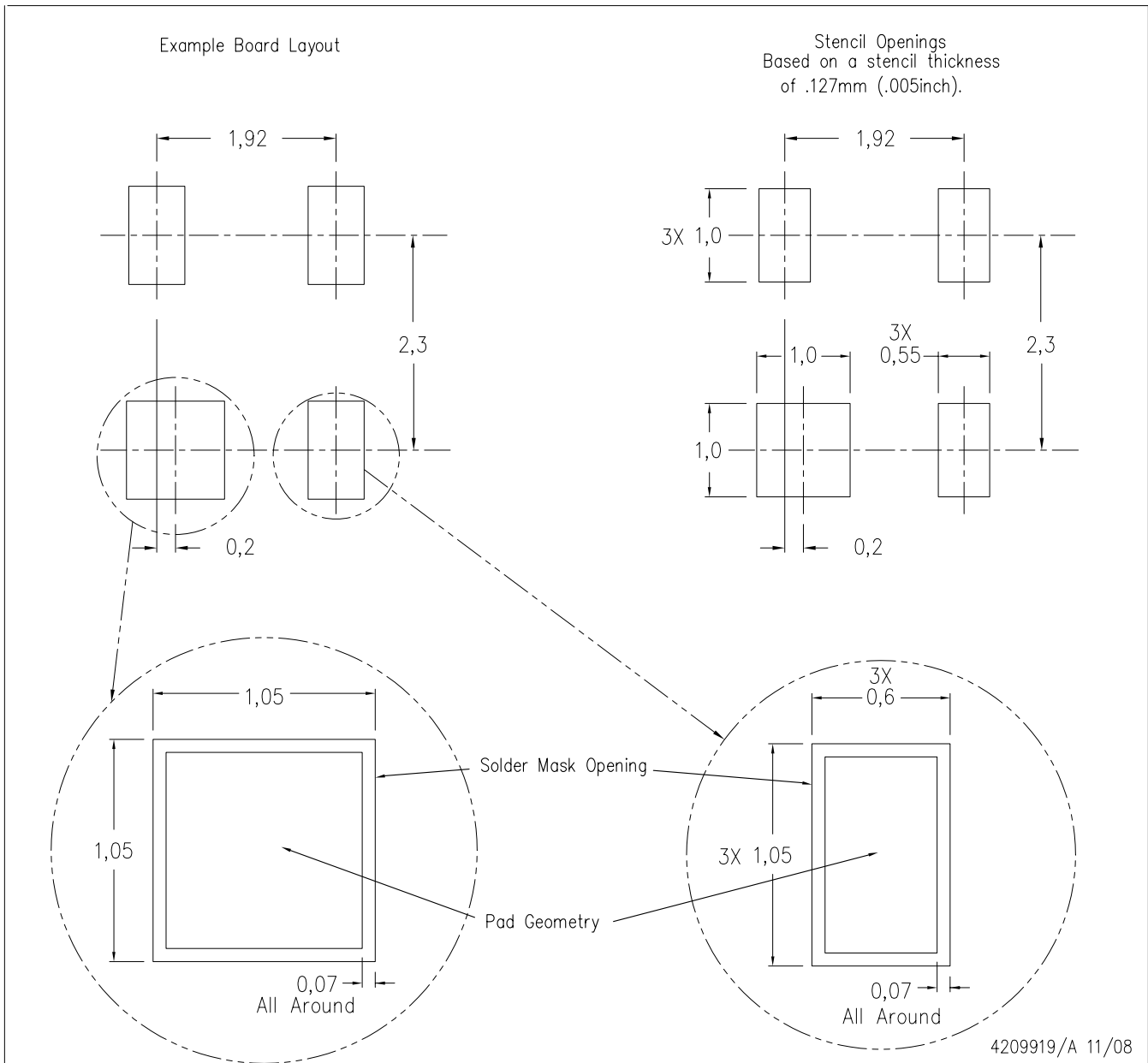

- NOTES:
- A. All linear dimensions are in millimeters.
 - B. This drawing is subject to change without notice.
 - C. Customers should place a note on the circuit board fabrication drawing not to alter the center solder mask defined pad.
 - D. Publication IPC-7351 is recommended for alternate designs.
 - E. Laser cutting apertures with trapezoidal walls and also rounding corners will offer better paste release. Customers should contact their board assembly site for stencil design recommendations. Refer to IPC-7525 for other stencil recommendations.

DRY (R-PUSON-N6)

PLASTIC SMALL OUTLINE NO-LEAD

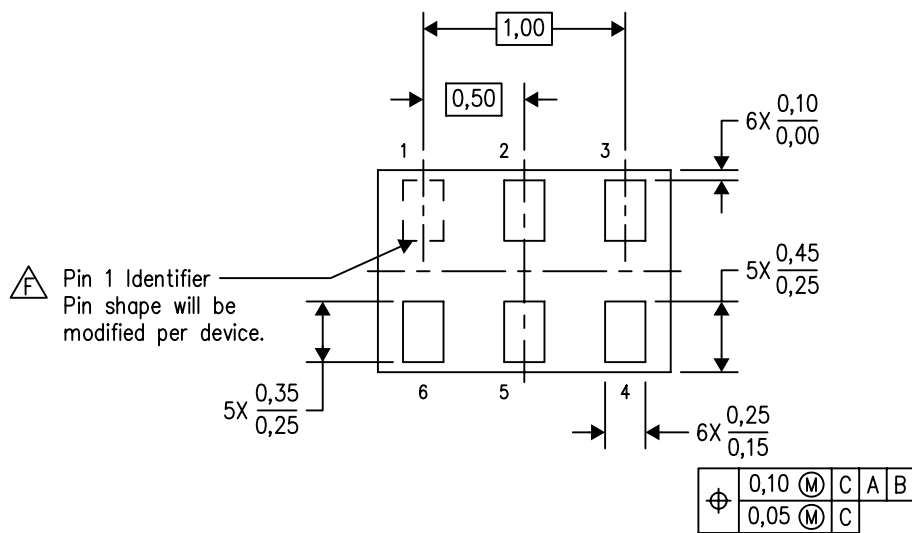
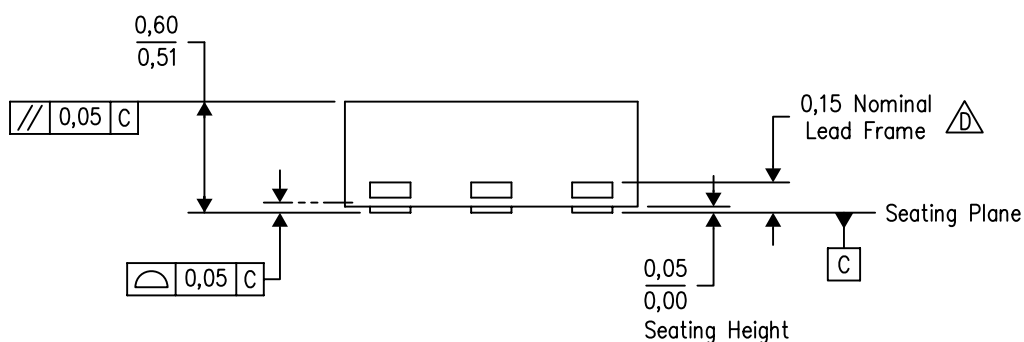
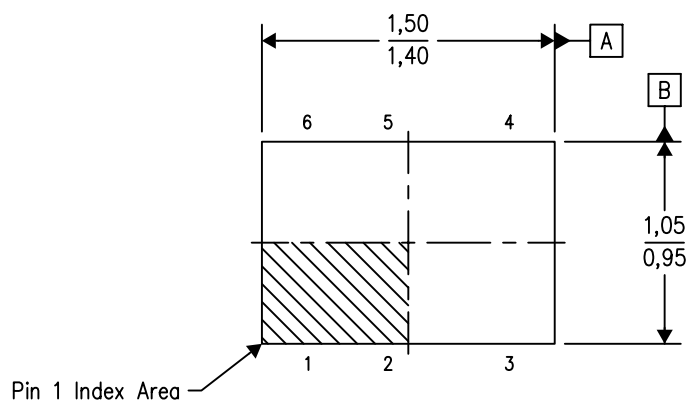

Bottom View

4207181/F 12/11

- NOTES:
- A. All linear dimensions are in millimeters. Dimensioning and tolerancing per ASME Y14.5M-1994.
 - B. This drawing is subject to change without notice.
 - C. SON (Small Outline No-Lead) package configuration.
 - The exposed lead frame feature on side of package may or may not be present due to alternative lead frame designs.
 - E. This package complies to JEDEC MO-287 variation UFAD.
 - See the additional figure in the Product Data Sheet for details regarding the pin 1 identifier shape.

DRY (R-PUSON-N6)

PLASTIC SMALL OUTLINE NO-LEAD

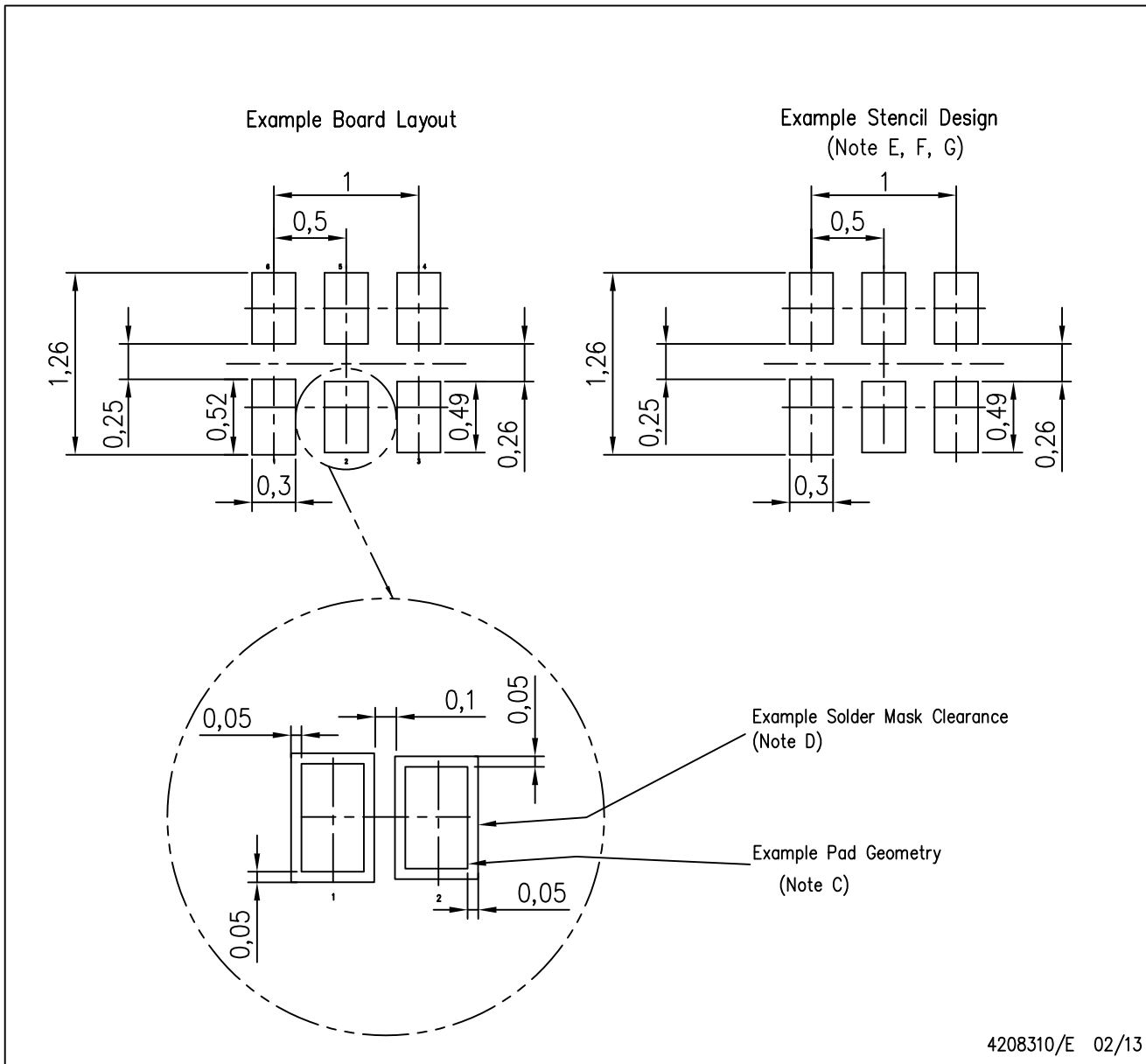

- NOTES:
- All linear dimensions are in millimeters.
 - This drawing is subject to change without notice.
 - Publication IPC-7351 is recommended for alternate designs.
 - Customers should contact their board fabrication site for minimum solder mask web tolerances between signal pads.
 - Maximum stencil thickness 0,127 mm (5 mils). All linear dimensions are in millimeters.
 - Laser cutting apertures with trapezoidal walls and also rounding corners will offer better paste release. Customers should contact their board assembly site for stencil design recommendations. Refer to IPC 7525 for stencil design considerations.
 - Side aperture dimensions over-print land for acceptable area ratio > 0.66 . Customer may reduce side aperture dimensions if stencil manufacturing process allows for sufficient release at smaller opening.