

EMI FILTER WITH INTEGRATED V_{CC} CLAMP FOR SIM CARD INTERFACE

Check for Samples: [TPD3F303](#)

FEATURES

- Bidirectional EMI/RFI Filtering and Line Termination with Integrated ESD Protection
- Robust ESD Protection Exceeds IEC 61000-4-2 (Level 4)
 - ± 15 -kV Human-Body Model (HBM)
 - ± 15 -kV IEC 61000-4-2 (Contact Discharge)
 - ± 15 -kV IEC 61000-4-2 (Air-Gap Discharge)
- Breakdown voltage 6-V
- Low Noise C-R-C Filter Topology
- Integrated V_{CC} Clamp Eliminates the Need for External ESD Protection
- Space Saving DPV (0.5-mm Pitch), DQD Packages (0.4-mm Pitch)

APPLICATIONS

- Mobile handsets
- PDAs
- Video Consoles
- Portable Computers

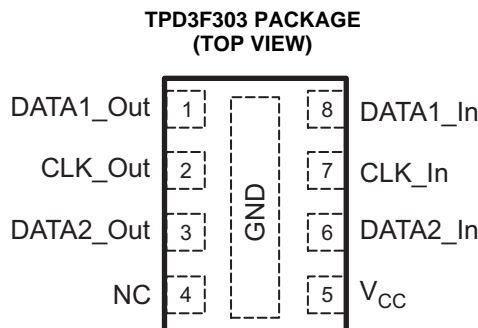

2.1-mm x 1.6-mm DPV (0.5-mm Pitch)
1.7-mm x 1.35-mm DQD (0.4-mm Pitch)

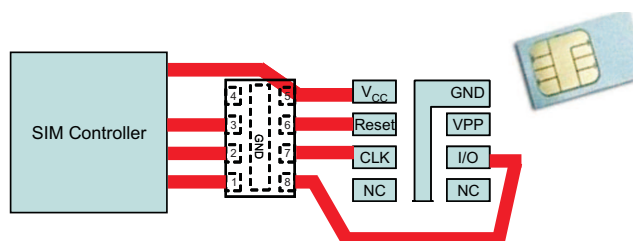

Figure 1. Board Layout with TPD3F303 at the SIM Card Interface

DESCRIPTION/ORDERING INFORMATION

The TPD3F303 is a 3-ch integrated EMI filter for SIM interface. This device integrates a V_{CC} clamp to provide system level ESD protection at the V_{CC} line. Termination resistor value of $47\ \Omega$ is included on the CLK line, while a $100\ \Omega$ termination is employed at the DATA and RST line.

The low-pass filter arrays reduce EMI emissions and provide system level ESD protection. Because of its small package and easy-to-use pin assignments, the TPD3F303 filter is suitable for a wide array of applications such as mobile handsets, PDAs, video consoles, notebook computers, etc.

The TPD3F303 is designed to suppress EMI/RFI noise in systems subjected to electromagnetic interferences. These filter series include an ESD protection circuitry which prevents damage to the application when subjected to ESD stress far exceeding IEC 61000-4-2 (Level 4). The TPD3F303 is specified for -40°C to 85°C operation.

ORDERING INFORMATION

| T_A | PACKAGE ⁽¹⁾ ⁽²⁾ | | ORDERABLE PART NUMBER | TOP-SIDE MARKING |
|---|---------------------------------------|---------------|-----------------------|------------------|
| -40°C to 85°C | 8 – DPV | Tape and reel | TPD3F303DPVR | 6SS |
| | 8 – DQD | Tape and reel | TPD3F303DQDR | 6SS |

(1) Package drawings, thermal data, and symbolization are available at www.ti.com/packaging.

(2) For the most current package and ordering information, see the Package Option Addendum at the end of this document, or see the TI website at www.ti.com.



Please be aware that an important notice concerning availability, standard warranty, and use in critical applications of Texas Instruments semiconductor products and disclaimers thereto appears at the end of this data sheet.

CIRCUIT DIAGRAMS

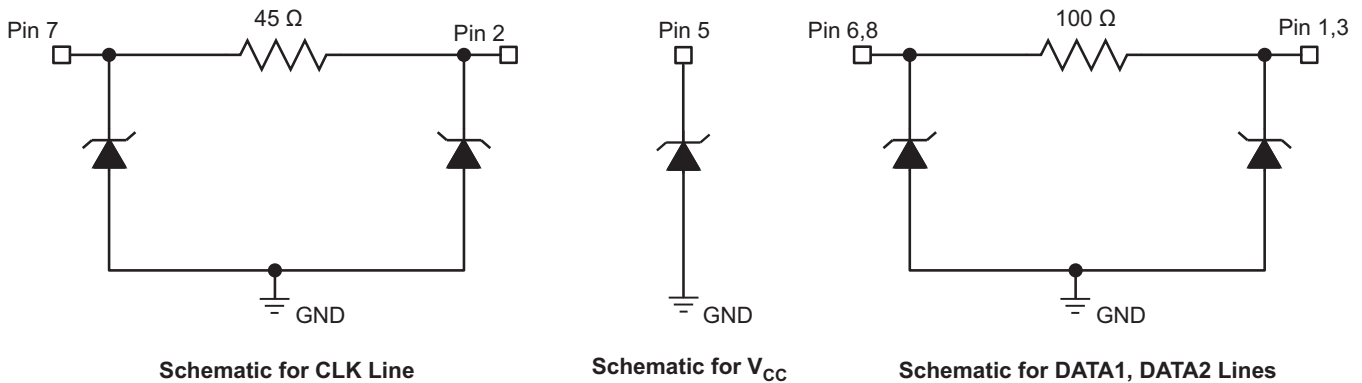

TERMINAL FUNCTIONS

| TERMINAL | | TYPE | DESCRIPTION |
|---|--------------------|--------------------|---|
| NAME | DPV/DQD PIN NO. | | |
| DATA _x _IN, DATA _x _OUT | 1, 3, 6, 8 | Input, Output Pins | Data and Rest signals Input, Output pins. The DATA1 and DATA2 are symmetric circuits. They can be used interchangeably for either DATA or RESET pins based off board layout scheme. |
| CLK_OUT, CLK_IN V | 2, 7 | Input, Output Pins | Clock Input and Output signals. |
| V _{CC} | 5 | Power Clamp | ESD Clamp circuit for the V _{CC} pin. |
| NC | 4 | No Connect | Not connected to any internal circuit. Leave this pin floating. |
| GND | Central ground Pad | Ground | Ground connection for the EMI filter. It is very important to connect the device GND to the printed circuit board ground plane through Vias directly under the package. |

ABSOLUTE MAXIMUM RATINGS⁽¹⁾

over operating free-air temperature range (unless otherwise noted)

| | | MIN | MAX | UNIT |
|------------------|--------------------------------------|-----|-----|------|
| | IO voltage tolerance | | 5.5 | V |
| T _A | Operating free-air temperature range | -40 | 85 | °C |
| T _{stg} | Storage temperature range | -55 | 155 | °C |
| | IEC 61000-4-2 Contact Discharge | | ±15 | KV |
| | IEC 61000-4-2 Air-gap Discharge | | ±15 | KV |
| | Human Body Model ESD | | ±15 | KV |

(1) Stresses beyond those listed under "ABSOLUTE MAXIMUM RATINGS" may cause permanent damage to the device. These are stress ratings only, and functional operation of the device at these or any other conditions beyond those indicated in the operational sections of the specifications is not implied. Exposure to absolute maximum-rated conditions for extended periods may affect device reliability.

ELECTRICAL CHARACTERISTICS

over operating free-air temperature range (unless otherwise noted)

| PARAMETER | | TEST CONDITIONS | | MIN | TYP | MAX | UNIT |
|----------------------|------------------------------|--|------------------|-----|-----|-----|------|
| V _{clamp} | Clamp voltage | I _{IO} = ±2 A | IO pin to ground | | | ±10 | V |
| I _l | Leakage current | R _{PU} = Open | IO pin to ground | | | 0.1 | µA |
| R _{CLK} | CLK series resistors | | | 40 | 47 | 55 | Ω |
| R _{DAT_RST} | Data/RST series resistors | | | 85 | 100 | 115 | Ω |
| C _{Total} | IO Capacitance | V _{IO} = 0 V | IO Pins to GND | 16 | 20 | 24 | pF |
| V _{BR} | Break-down Voltage | I _{IO} = 1 mA | | 6 | | | V |
| F _{-3dB} | -3 dB BW for DATA/RESET line | Z _{SOURCE} = 50 Ω Z _{LOAD} = 50 Ω | | | 294 | | MHz |

ELECTRICAL CHARACTERISTICS (continued)

over operating free-air temperature range (unless otherwise noted)

| PARAMETER | | TEST CONDITIONS | MIN | TYP | MAX | UNIT |
|-------------------|-----------------------|--|-----|-----|-----|------|
| F _{-3dB} | -3 dB BW for CLK line | Z _{SOURCE} = 50 Ω Z _{LOAD} = 50 Ω | | 308 | | MHz |

TYPICAL OPERATING CHARACTERISTICS

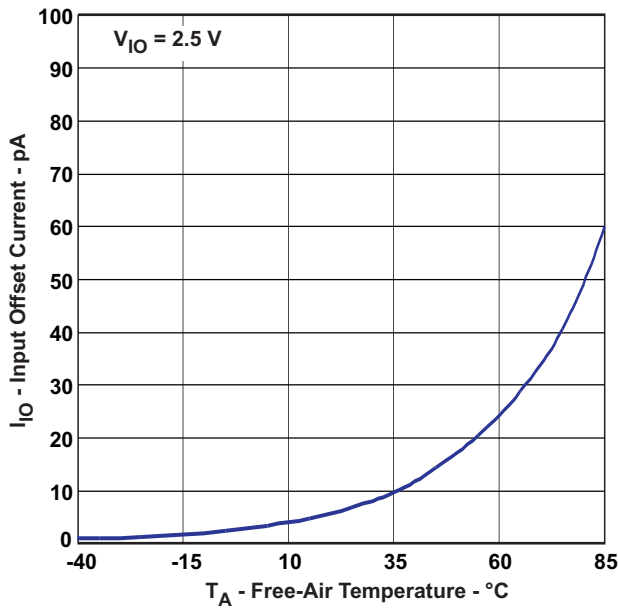

Figure 2. I_{IO} vs Temperature, $V_{IO} = 2.5V$

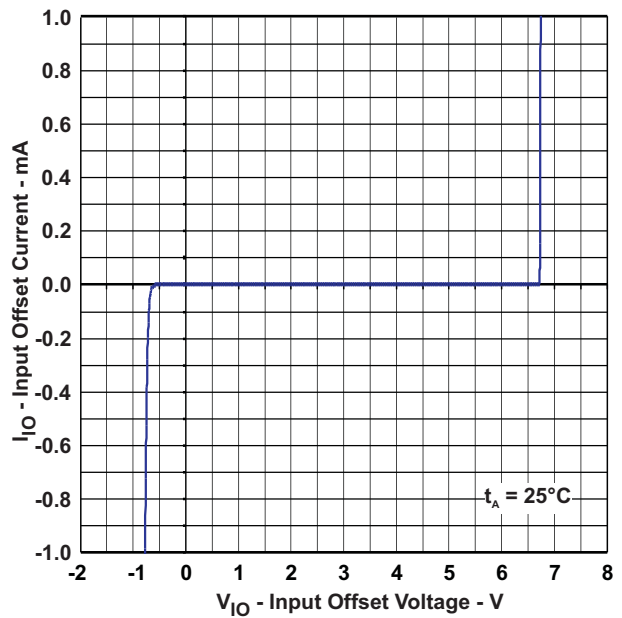

Figure 3. I_{IO} vs V_{IO}

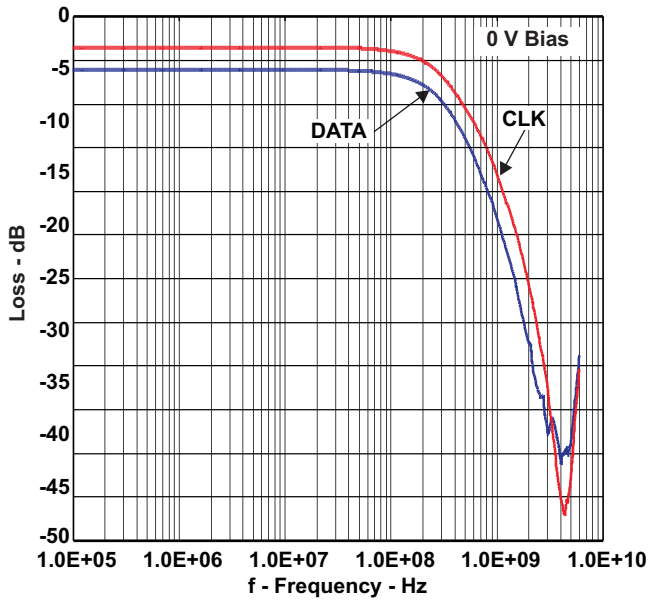

Figure 4. Frequency Response Data (0 V Bias)

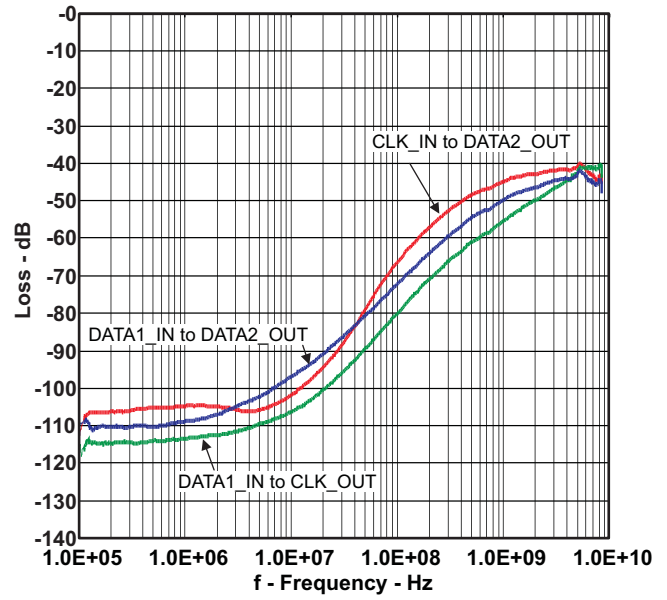

Figure 5. Channel-to-Channel Crosstalk

TYPICAL OPERATING CHARACTERISTICS (continued)

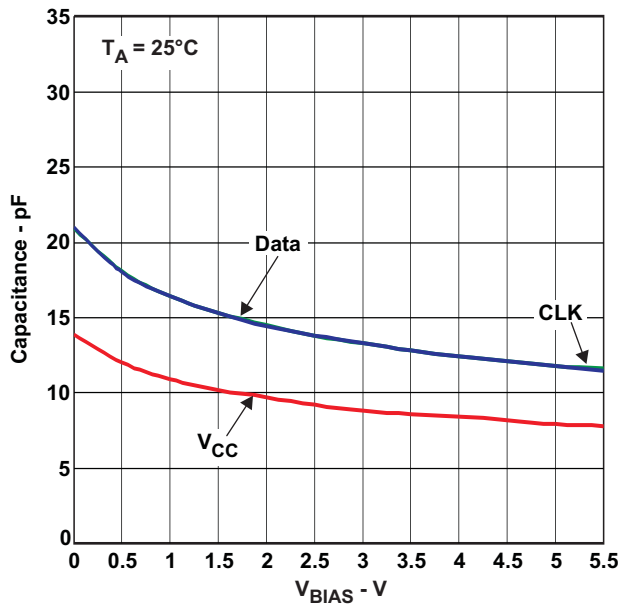

Figure 6. Capacitance vs V_{BIAS} , $t_A = 25^\circ\text{C}$

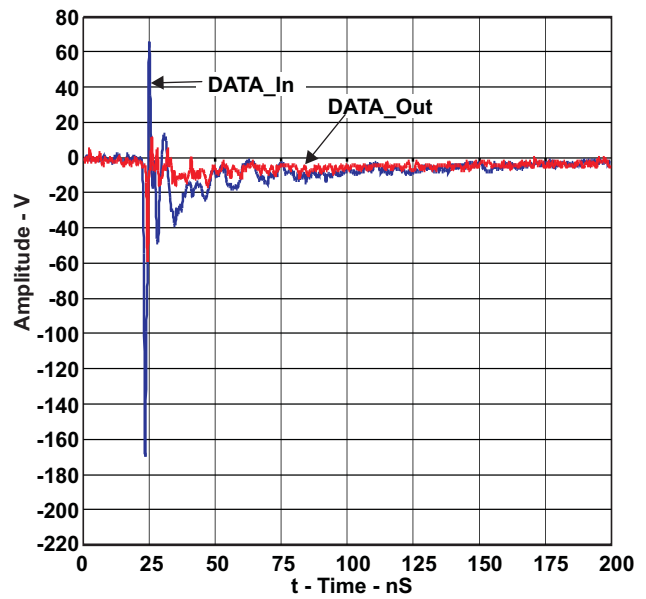

Figure 7. IEC Clamping Waveforms
-15 kV Contact, DATA1_In Stressed

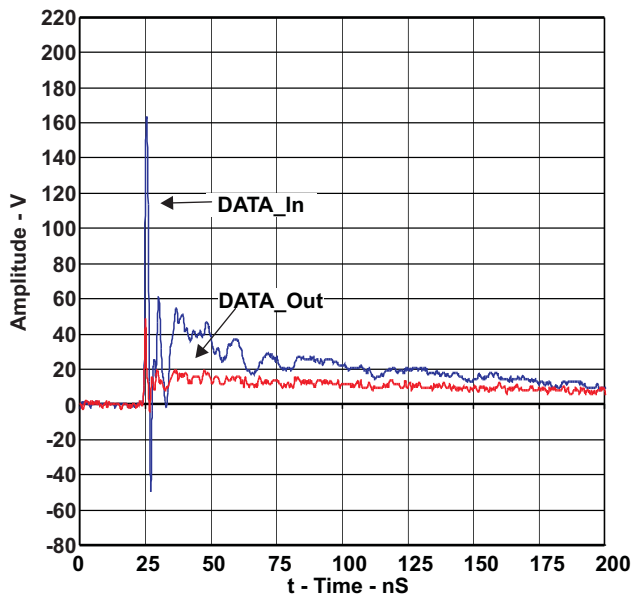

Figure 8. IEC Clamping Waveforms
+15 kV Contact, DATA1_In Stressed

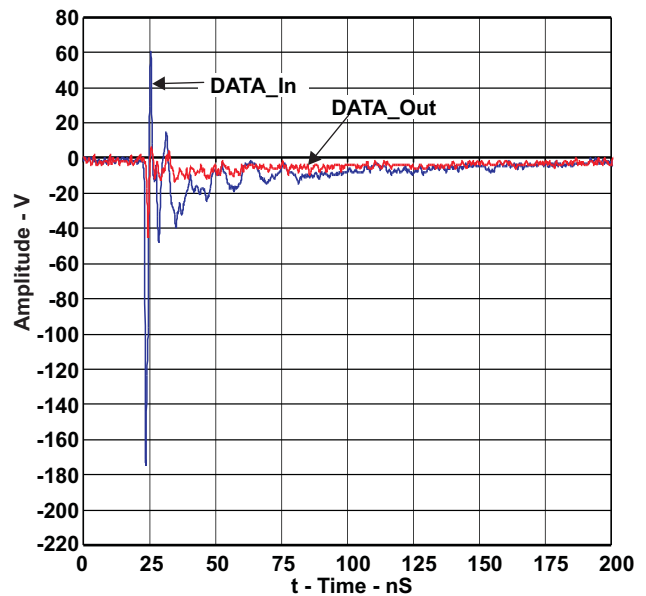
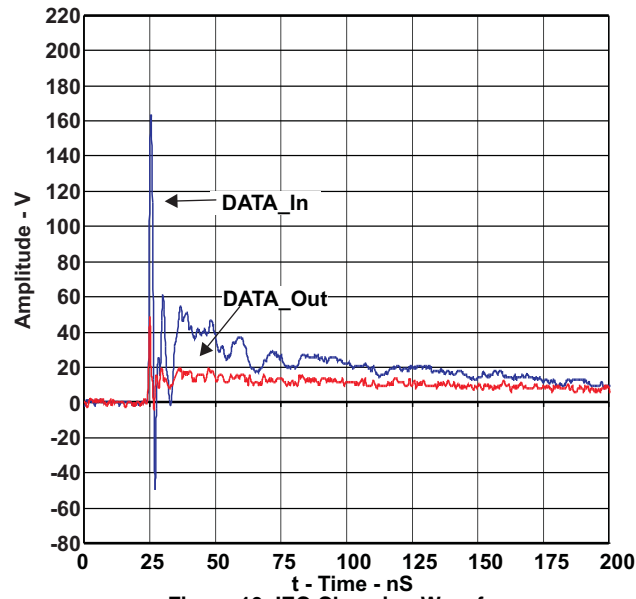

Figure 9. IEC Clamping Waveforms
-15 kV Contact, CLK_In Stressed

TYPICAL OPERATING CHARACTERISTICS (continued)



**Figure 10. IEC Clamping Waveforms
+15 kV Contact, CLK_In Stressed**

PACKAGING INFORMATION

| Orderable Device | Status (1) | Package Type | Package Drawing | Pins | Package Qty | Eco Plan (2) | Lead/Ball Finish (6) | MSL Peak Temp (3) | Op Temp (°C) | Device Marking (4/5) | Samples |
|------------------|---------------|--------------|-----------------|------|-------------|-------------------------|-------------------------|----------------------|--------------|-------------------------|-------------------------|
| TPD3F303DPVR | ACTIVE | USON | DPV | 8 | 3000 | Green (RoHS & no Sb/Br) | CU NIPDAU | Level-1-260C-UNLIM | -40 to 85 | 6SS | Samples |
| TPD3F303DQDR | ACTIVE | WSON | DQD | 8 | 3000 | Green (RoHS & no Sb/Br) | CU NIPDAU | Level-1-260C-UNLIM | -40 to 85 | 6SS | Samples |

(1) The marketing status values are defined as follows:

ACTIVE: Product device recommended for new designs.

LIFEBUY: TI has announced that the device will be discontinued, and a lifetime-buy period is in effect.

NRND: Not recommended for new designs. Device is in production to support existing customers, but TI does not recommend using this part in a new design.

PREVIEW: Device has been announced but is not in production. Samples may or may not be available.

OBSOLETE: TI has discontinued the production of the device.

(2) Eco Plan - The planned eco-friendly classification: Pb-Free (RoHS), Pb-Free (RoHS Exempt), or Green (RoHS & no Sb/Br) - please check <http://www.ti.com/productcontent> for the latest availability information and additional product content details.

TBD: The Pb-Free/Green conversion plan has not been defined.

Pb-Free (RoHS): TI's terms "Lead-Free" or "Pb-Free" mean semiconductor products that are compatible with the current RoHS requirements for all 6 substances, including the requirement that lead not exceed 0.1% by weight in homogeneous materials. Where designed to be soldered at high temperatures, TI Pb-Free products are suitable for use in specified lead-free processes.

Pb-Free (RoHS Exempt): This component has a RoHS exemption for either 1) lead-based flip-chip solder bumps used between the die and package, or 2) lead-based die adhesive used between the die and leadframe. The component is otherwise considered Pb-Free (RoHS compatible) as defined above.

Green (RoHS & no Sb/Br): TI defines "Green" to mean Pb-Free (RoHS compatible), and free of Bromine (Br) and Antimony (Sb) based flame retardants (Br or Sb do not exceed 0.1% by weight in homogeneous material)

(3) MSL, Peak Temp. - The Moisture Sensitivity Level rating according to the JEDEC industry standard classifications, and peak solder temperature.

(4) There may be additional marking, which relates to the logo, the lot trace code information, or the environmental category on the device.

(5) Multiple Device Markings will be inside parentheses. Only one Device Marking contained in parentheses and separated by a "~" will appear on a device. If a line is indented then it is a continuation of the previous line and the two combined represent the entire Device Marking for that device.

(6) Lead/Ball Finish - Orderable Devices may have multiple material finish options. Finish options are separated by a vertical ruled line. Lead/Ball Finish values may wrap to two lines if the finish value exceeds the maximum column width.

Important Information and Disclaimer: The information provided on this page represents TI's knowledge and belief as of the date that it is provided. TI bases its knowledge and belief on information provided by third parties, and makes no representation or warranty as to the accuracy of such information. Efforts are underway to better integrate information from third parties. TI has taken and continues to take reasonable steps to provide representative and accurate information but may not have conducted destructive testing or chemical analysis on incoming materials and chemicals. TI and TI suppliers consider certain information to be proprietary, and thus CAS numbers and other limited information may not be available for release.

In no event shall TI's liability arising out of such information exceed the total purchase price of the TI part(s) at issue in this document sold by TI to Customer on an annual basis.

TAPE AND REEL INFORMATION



QUADRANT ASSIGNMENTS FOR PIN 1 ORIENTATION IN TAPE



*All dimensions are nominal

| Device | Package Type | Package Drawing | Pins | SPQ | Reel Diameter (mm) | Reel Width W1 (mm) | A0 (mm) | B0 (mm) | K0 (mm) | P1 (mm) | W (mm) | Pin1 Quadrant |
|--------------|--------------|-----------------|------|------|--------------------|--------------------|---------|---------|---------|---------|--------|---------------|
| TPD3F303DPVR | USON | DPV | 8 | 3000 | 180.0 | 8.4 | 1.84 | 2.32 | 0.78 | 4.0 | 8.0 | Q1 |
| TPD3F303DQDR | WSON | DQD | 8 | 3000 | 180.0 | 8.4 | 1.65 | 2.0 | 0.95 | 4.0 | 8.0 | Q1 |

TAPE AND REEL BOX DIMENSIONS

*All dimensions are nominal

| Device | Package Type | Package Drawing | Pins | SPQ | Length (mm) | Width (mm) | Height (mm) |
|--------------|--------------|-----------------|------|------|-------------|------------|-------------|
| TPD3F303DPVR | USON | DPV | 8 | 3000 | 202.0 | 201.0 | 28.0 |
| TPD3F303DQDR | WSON | DQD | 8 | 3000 | 202.0 | 201.0 | 28.0 |

DQD (R-PWSON-N8)

PLASTIC SMALL OUTLINE NO-LEAD

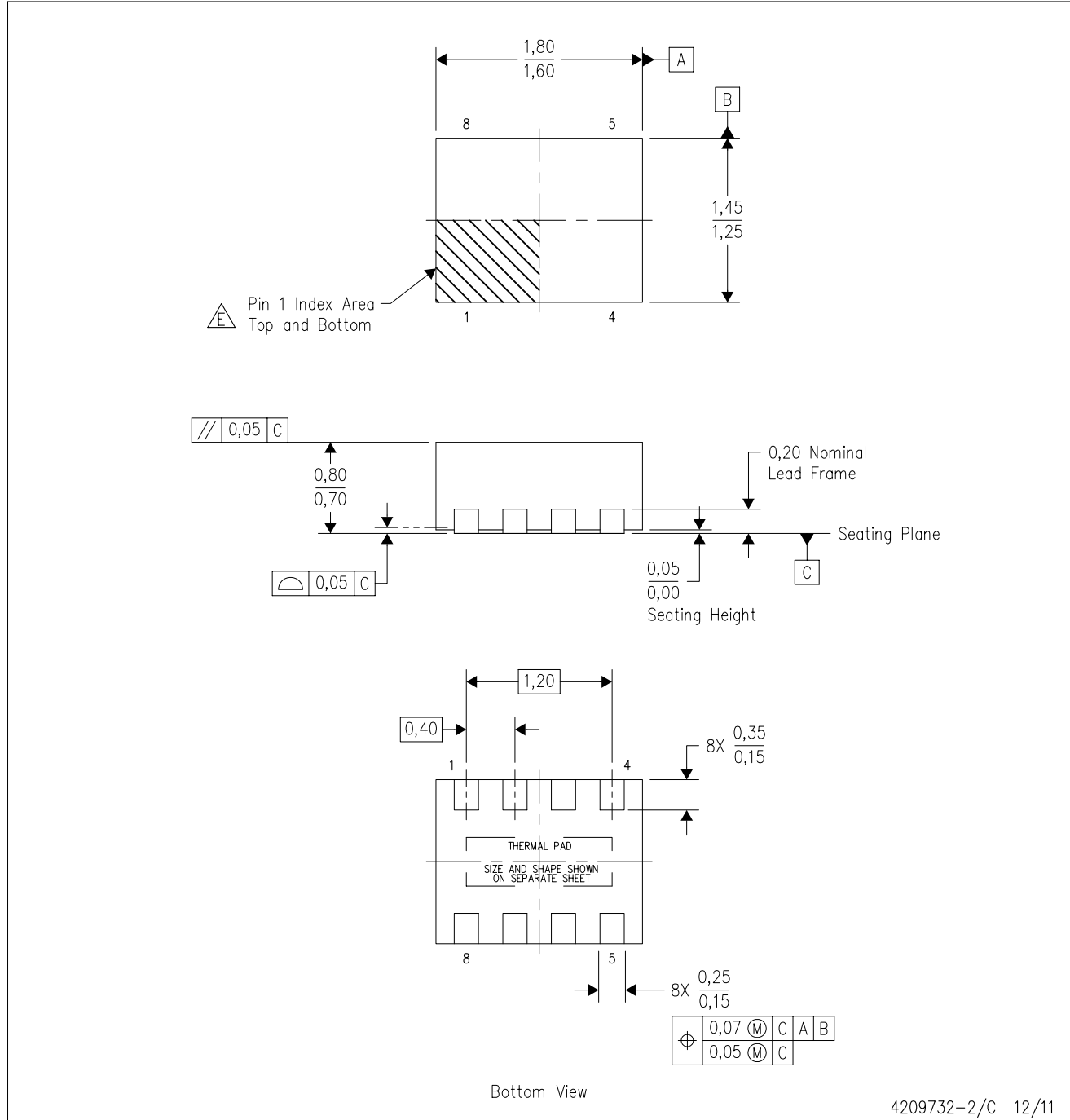

- NOTES:
- All linear dimensions are in millimeters. Dimensioning and tolerancing per ASME Y14.5M-1994.
 - This drawing is subject to change without notice.
 - SON (Small Outline No-Lead) package configuration.
 - The package thermal pad must be soldered to the board for thermal and mechanical performance.
 - See the additional figure in the Product Data Sheet for details regarding the exposed thermal pad features and dimensions.
- △ Pin 1 identifiers are located on both top and bottom of the package and within the zone indicated. The Pin 1 identifiers are either a molded, marked, or metal feature.

THERMAL PAD MECHANICAL DATA

DQD (R-PWSON-N8)

PLASTIC SMALL OUTLINE NO-LEAD

THERMAL INFORMATION

This package incorporates an exposed thermal pad that is designed to be attached directly to an external heatsink. The thermal pad must be soldered directly to the printed circuit board (PCB). After soldering, the PCB can be used as a heatsink. In addition, through the use of thermal vias, the thermal pad can be attached directly to the appropriate copper plane shown in the electrical schematic for the device, or alternatively, can be attached to a special heatsink structure designed into the PCB. This design optimizes the heat transfer from the integrated circuit (IC).

For information on the Quad Flatpack No-Lead (QFN) package and its advantages, refer to Application Report, QFN/SON PCB Attachment, Texas Instruments Literature No. SLUA271. This document is available at www.ti.com.

The exposed thermal pad dimensions for this package are shown in the following illustration.

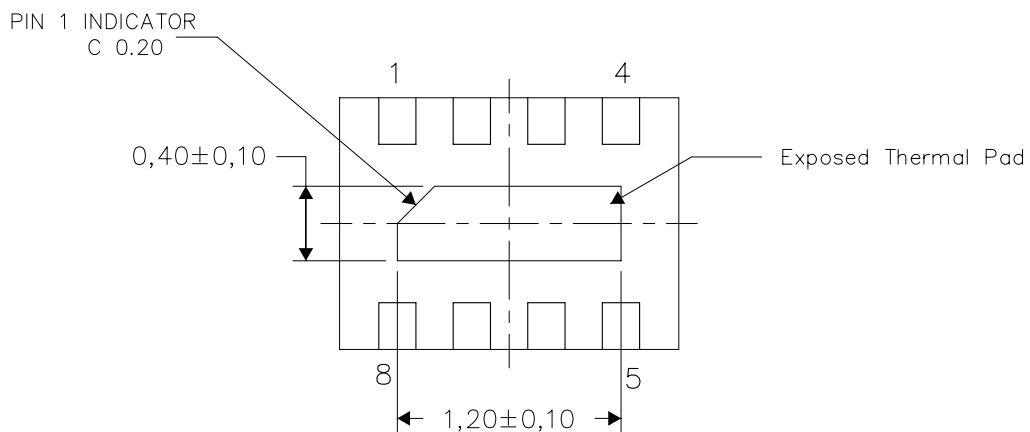

Bottom View

Exposed Thermal Pad Dimensions

4209733-2/C 12/11

NOTE: All linear dimensions are in millimeters

DQD (R-PWSON-N8)

PLASTIC SMALL OUTLINE NO-LEAD

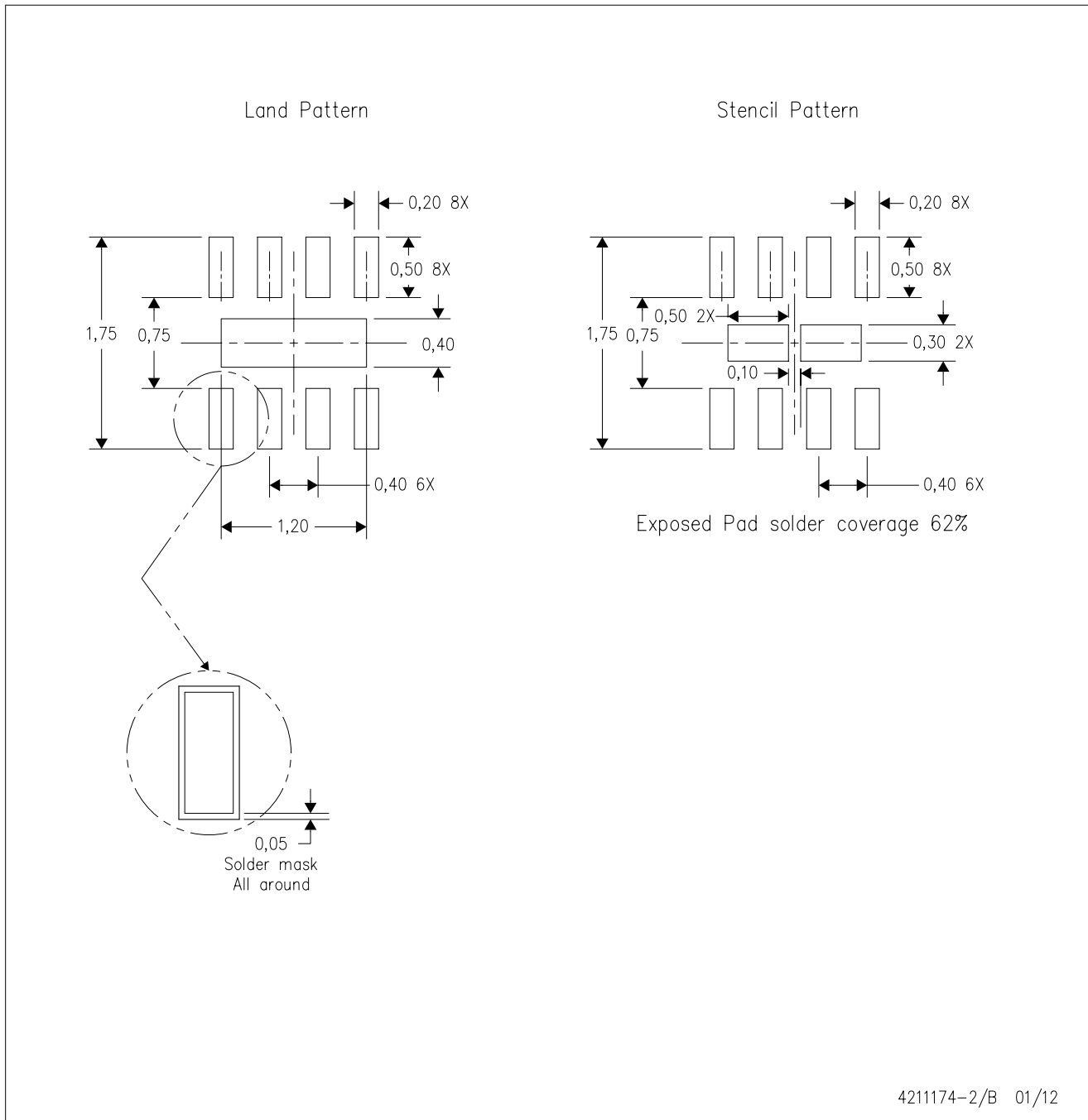

- NOTES:
- A. All linear dimensions are in millimeters.
 - B. This drawing is subject to change without notice.
 - C. Publication IPC-7351 is recommended for alternate designs.
 - D. Customers should contact their board fabrication site for minimum solder mask web tolerances between signal pads.
 - E. Maximum stencil thickness 0,1016 mm (4 mils). All linear dimensions are in millimeters.
 - F. Laser cutting apertures with trapezoidal walls and also rounding corners will offer better paste release. Customers should contact their board assembly site for stencil design recommendations. Refer to IPC 7525 for stencil design considerations.
 - G. Side aperture dimensions over-print land for acceptable area ratio > 0.66. Customer may reduce side aperture dimensions if stencil manufacturing process allows for sufficient release at smaller opening.

DPV (R-PUSON-N8)

PLASTIC SMALL OUTLINE NO-LEAD

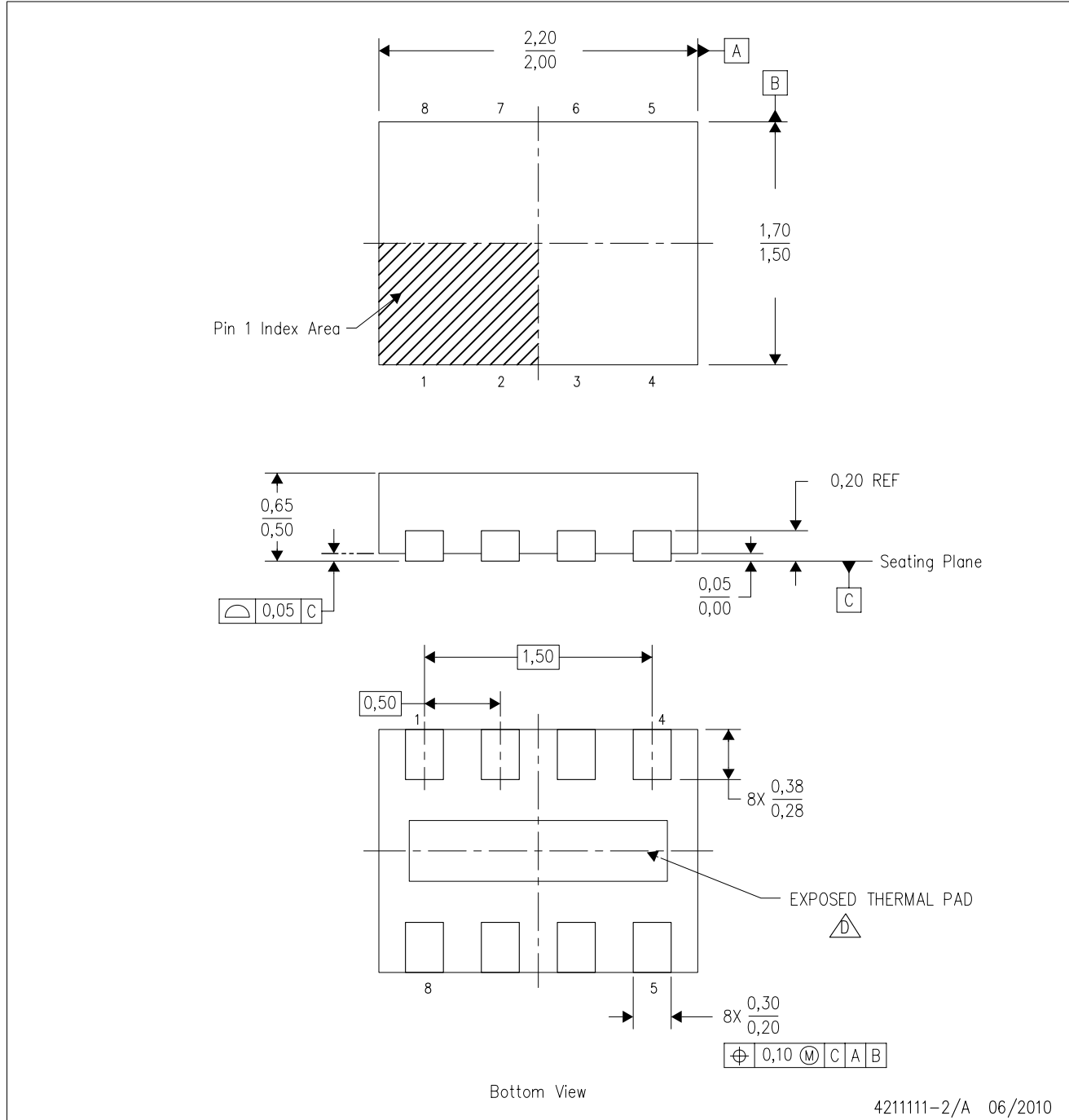

421111-2/A 06/2010

- NOTES:
- A. All linear dimensions are in millimeters. Dimensioning and tolerancing per ASME Y14.5M-1994.
 - B. This drawing is subject to change without notice.
 - C. SON (Small Outline No-Lead) package configuration.
 - The package thermal pad must be soldered to the board for thermal and mechanical performance.

THERMAL PAD MECHANICAL DATA

DPV (R-PUSON-N8)

PLASTIC SMALL OUTLINE NO-LEAD

THERMAL INFORMATION

This package incorporates an exposed thermal pad that is designed to be attached directly to an external heatsink. The thermal pad must be soldered directly to the printed circuit board (PCB). After soldering, the PCB can be used as a heatsink. In addition, through the use of thermal vias, the thermal pad can be attached directly to the appropriate copper plane shown in the electrical schematic for the device, or alternatively, can be attached to a special heatsink structure designed into the PCB. This design optimizes the heat transfer from the integrated circuit (IC).

For information on the Quad Flatpack No-Lead (QFN) package and its advantages, refer to Application Report, QFN/SON PCB Attachment, Texas Instruments Literature No. SLUA271. This document is available at www.ti.com.

The exposed thermal pad dimensions for this package are shown in the following illustration.

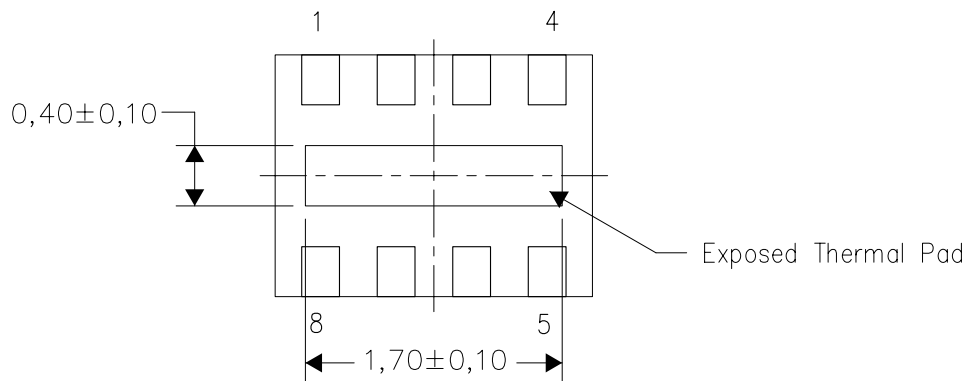

Bottom View

Exposed Thermal Pad Dimensions

4211680/A 04/11

NOTE: A. All linear dimensions are in millimeters

IMPORTANT NOTICE

Texas Instruments Incorporated and its subsidiaries (TI) reserve the right to make corrections, enhancements, improvements and other changes to its semiconductor products and services per JESD46, latest issue, and to discontinue any product or service per JESD48, latest issue. Buyers should obtain the latest relevant information before placing orders and should verify that such information is current and complete. All semiconductor products (also referred to herein as "components") are sold subject to TI's terms and conditions of sale supplied at the time of order acknowledgment.

TI warrants performance of its components to the specifications applicable at the time of sale, in accordance with the warranty in TI's terms and conditions of sale of semiconductor products. Testing and other quality control techniques are used to the extent TI deems necessary to support this warranty. Except where mandated by applicable law, testing of all parameters of each component is not necessarily performed.

TI assumes no liability for applications assistance or the design of Buyers' products. Buyers are responsible for their products and applications using TI components. To minimize the risks associated with Buyers' products and applications, Buyers should provide adequate design and operating safeguards.

TI does not warrant or represent that any license, either express or implied, is granted under any patent right, copyright, mask work right, or other intellectual property right relating to any combination, machine, or process in which TI components or services are used. Information published by TI regarding third-party products or services does not constitute a license to use such products or services or a warranty or endorsement thereof. Use of such information may require a license from a third party under the patents or other intellectual property of the third party, or a license from TI under the patents or other intellectual property of TI.

Reproduction of significant portions of TI information in TI data books or data sheets is permissible only if reproduction is without alteration and is accompanied by all associated warranties, conditions, limitations, and notices. TI is not responsible or liable for such altered documentation. Information of third parties may be subject to additional restrictions.

Resale of TI components or services with statements different from or beyond the parameters stated by TI for that component or service voids all express and any implied warranties for the associated TI component or service and is an unfair and deceptive business practice. TI is not responsible or liable for any such statements.

Buyer acknowledges and agrees that it is solely responsible for compliance with all legal, regulatory and safety-related requirements concerning its products, and any use of TI components in its applications, notwithstanding any applications-related information or support that may be provided by TI. Buyer represents and agrees that it has all the necessary expertise to create and implement safeguards which anticipate dangerous consequences of failures, monitor failures and their consequences, lessen the likelihood of failures that might cause harm and take appropriate remedial actions. Buyer will fully indemnify TI and its representatives against any damages arising out of the use of any TI components in safety-critical applications.

In some cases, TI components may be promoted specifically to facilitate safety-related applications. With such components, TI's goal is to help enable customers to design and create their own end-product solutions that meet applicable functional safety standards and requirements. Nonetheless, such components are subject to these terms.

No TI components are authorized for use in FDA Class III (or similar life-critical medical equipment) unless authorized officers of the parties have executed a special agreement specifically governing such use.

Only those TI components which TI has specifically designated as military grade or "enhanced plastic" are designed and intended for use in military/aerospace applications or environments. Buyer acknowledges and agrees that any military or aerospace use of TI components which have **not** been so designated is solely at the Buyer's risk, and that Buyer is solely responsible for compliance with all legal and regulatory requirements in connection with such use.

TI has specifically designated certain components as meeting ISO/TS16949 requirements, mainly for automotive use. In any case of use of non-designated products, TI will not be responsible for any failure to meet ISO/TS16949.

Products

| | |
|------------------------------|--|
| Audio | www.ti.com/audio |
| Amplifiers | amplifier.ti.com |
| Data Converters | dataconverter.ti.com |
| DLP® Products | www.dlp.com |
| DSP | dsp.ti.com |
| Clocks and Timers | www.ti.com/clocks |
| Interface | interface.ti.com |
| Logic | logic.ti.com |
| Power Mgmt | power.ti.com |
| Microcontrollers | microcontroller.ti.com |
| RFID | www.ti-rfid.com |
| OMAP Applications Processors | www.ti.com/omap |
| Wireless Connectivity | www.ti.com/wirelessconnectivity |

Applications

| | |
|-------------------------------|--|
| Automotive and Transportation | www.ti.com/automotive |
| Communications and Telecom | www.ti.com/communications |
| Computers and Peripherals | www.ti.com/computers |
| Consumer Electronics | www.ti.com/consumer-apps |
| Energy and Lighting | www.ti.com/energy |
| Industrial | www.ti.com/industrial |
| Medical | www.ti.com/medical |
| Security | www.ti.com/security |
| Space, Avionics and Defense | www.ti.com/space-avionics-defense |
| Video and Imaging | www.ti.com/video |

TI E2E Community

e2e.ti.com