

## TPIC6C596 Power Logic 8-Bit Shift Register

### 1 Features

- Low  $R_{DS(on)}$ , 7  $\Omega$  (Typical)
- Avalanche Energy, 30 mJ
- Eight Power DMOS Transistor Outputs of 100-mA Continuous Current
- 250-mA Current Limit Capability
- ESD Protection, 2500 V
- Output Clamp Voltage, 33 V
- Enhanced Cascading for Multiple Stages
- All Registers Cleared With Single Input
- Low Power Consumption

### 2 Applications

- Instrumentation Clusters
- Tell-Tale Lamps
- LED Illumination and Controls
- Automotive Relay or Solenoids Drivers

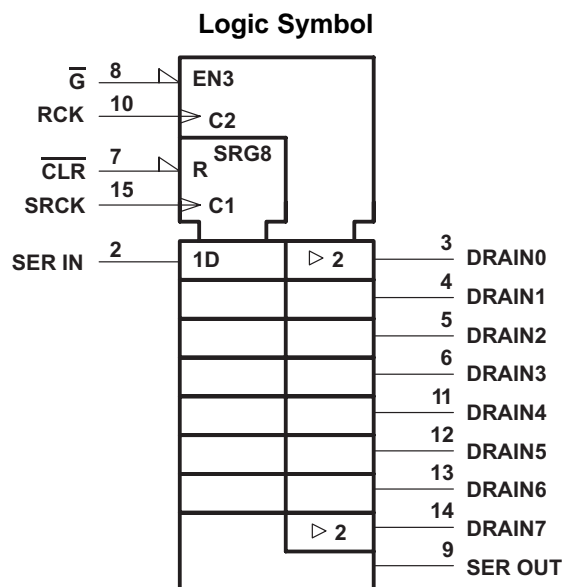

This symbol is in accordance with ANSI/IEEE Std 91-1984 and IEC Publication 617-12.

### 3 Description

The TPIC6C596 device is a monolithic, medium-voltage, low-current, 8-bit shift register designed for use in systems that require relatively moderate load power such as LEDs. The device contains a built-in voltage clamp on the outputs for inductive transient protection. Power driver applications include relays, solenoids, and other low-current or medium-voltage loads.

This device contains an 8-bit serial-in, parallel-out shift register that feeds an 8-bit D-type storage register. Data transfers through both the shift and storage registers on the rising edge of the shift register clock (SRCK) and the register clock (RCK), respectively. The storage register transfers data to the output buffer when shift register clear ( $\overline{CLR}$ ) is high. When  $\overline{CLR}$  is low, all registers in the device are cleared. When output enable ( $\overline{G}$ ) is held high, all data in the output buffers is held low and all drain outputs are off. When  $\overline{G}$  is held low, data from the storage register is transparent to the output buffers. When data in the output buffers is low, the DMOS transistor outputs are off. When data is high, the DMOS transistor outputs have sink-current capability.

The serial output (SER OUT) is clocked out of the device on the falling edge of SRCK to provide additional hold time for cascaded applications. This will provide improved performance for applications where clock signals may be skewed, devices are not located near one another, or the system must tolerate electromagnetic interference.

Outputs are low-side, open-drain DMOS transistors with output ratings of 33 V and 100 mA continuous sink-current capability. Each output provides a 250-mA maximum current limit at  $T_C = 25^\circ\text{C}$ . The current limit decreases as the junction temperature increases for additional device protection. The device also provides up to 2500 V of ESD protection when tested using the human body model and the 200-V machine model.

The TPIC6C596 device is characterized for operation over the operating case temperature range of  $-40^\circ\text{C}$  to  $125^\circ\text{C}$ .

#### Device Information<sup>(1)</sup>

PART NUMBER	PACKAGE	BODY SIZE (NOM)
TPIC6C596	SOIC (16)	9.90 mm x 3.91 mm
	PDIP (16)	19.30 mm x 6.35 mm
	TSSOP (16)	5.00 mm x 4.40 mm

(1) For all available packages, see the orderable addendum at the end of the data sheet.



## Table of Contents

<b>1 Features</b> ..... 1 <b>2 Applications</b> ..... 1 <b>3 Description</b> ..... 1 <b>4 Revision History</b> ..... 2 <b>5 Pin Configuration and Functions</b> ..... 3 <b>6 Specifications</b> ..... 4 6.1 Absolute Maximum Ratings ..... 4 6.2 ESD Ratings ..... 4 6.3 Recommended Operating Conditions ..... 4 6.4 Thermal Information ..... 5 6.5 Electrical Characteristics ..... 5 6.6 Switching Characteristics ..... 6 6.7 Typical Characteristics ..... 7 <b>7 Parameter Measurement Information</b> ..... 9 <b>8 Detailed Description</b> ..... 12 8.1 Overview ..... 12	8.2 Functional Block Diagram ..... 12 8.3 Feature Description ..... 13 8.4 Device Functional Modes ..... 13 <b>9 Application and Implementation</b> ..... 14 9.1 Application Information ..... 14 9.2 Typical Application ..... 14 <b>10 Power Supply Recommendations</b> ..... 17 <b>11 Layout</b> ..... 17 11.1 Layout Guidelines ..... 17 11.2 Layout Example ..... 18 11.3 Thermal Considerations ..... 19 <b>12 Device and Documentation Support</b> ..... 20 12.1 Trademarks ..... 20 12.2 Electrostatic Discharge Caution ..... 20 12.3 Glossary ..... 20 <b>13 Mechanical, Packaging, and Orderable Information</b> ..... 20
---	---

## 4 Revision History

### Changes from Revision C (April 2005) to Revision D

**Page**

- Added *ESD Ratings* table, *Feature Description* section, *Device Functional Modes*, *Application and Implementation* section, *Power Supply Recommendations* section, *Layout* section, *Device and Documentation Support* section, and *Mechanical, Packaging, and Orderable Information* section ..... 1

## 5 Pin Configuration and Functions

**D, N, or PW Packages  
16-Pin SOIC, PDIP, and TSSOP  
Top View**

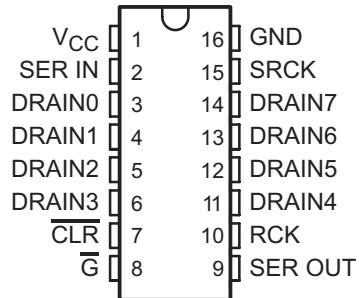

**Pin Functions**

PIN		I/O	DESCRIPTION
NAME	NO.		
CLR	7	I	Shift register clear, active-low
DRAIN0	3	O	Open-drain output
DRAIN1	4	O	Open-drain output
DRAIN2	5	O	Open-drain output
DRAIN3	6	O	Open-drain output
DRAIN4	11	O	Open-drain output
DRAIN5	12	O	Open-drain output
DRAIN6	13	O	Open-drain output
DRAIN7	14	O	Open-drain output
G	8	I	Output enable, active-low
GND	16	—	Power ground
RCK	10	I	Register clock
SER IN	2	I	Serial data input
SER OUT	9	O	Serial data output
SRCK	15	I	Shift register clock
VCC	1	I	Power supply

## 6 Specifications

### 6.1 Absolute Maximum Ratings

 over operating free-air temperature range (unless otherwise noted) <sup>(1)</sup>

		MIN	MAX	UNIT
V <sub>CC</sub>	Logic supply voltage <sup>(2)</sup>	–0.3	7	V
V <sub>I</sub>	Logic input voltage	–0.3	7	V
V <sub>DS</sub>	Power DMOS drain-to-source voltage <sup>(3)</sup>	–0.3	33	V
	Continuous source-to-drain diode anode current		250	mA
	Pulsed source-to-drain diode anode current <sup>(4)</sup>		500	mA
I <sub>D</sub>	Pulsed drain current, each output, all outputs on, T <sub>C</sub> = 25°C <sup>(4)</sup>		250	mA
I <sub>D</sub>	Continuous drain current, each output, all outputs on, T <sub>C</sub> = 25°C <sup>(4)</sup>		100	mA
I <sub>DM</sub>	Peak drain current single output, T <sub>C</sub> = 25°C <sup>(4)</sup>		250	mA
E <sub>AS</sub>	Single-pulse avalanche energy (see <a href="#">Figure 11</a> )		30	mJ
I <sub>AS</sub>	Avalanche current <sup>(5)</sup>		200	mA
	Continuous total dissipation	See <a href="#">Thermal Information</a>		
T <sub>C</sub>	Operating case temperature	–40	125	°C
T <sub>J</sub>	Operating virtual junction temperature	–40	150	°C
T <sub>stg</sub>	Storage temperature	–65	150	°C

- (1) Stresses beyond those listed under *Absolute Maximum Ratings* may cause permanent damage to the device. These are stress ratings only, which do not imply functional operation of the device at these or any other conditions beyond those indicated under *Recommended Operating Conditions*. Exposure to absolute-maximum-rated conditions for extended periods may affect device reliability.
- (2) All voltage values are with respect to GND.
- (3) Each power DMOS source is internally connected to GND.
- (4) Pulse duration ≤ 100 μs and duty cycle ≤ 2%.
- (5) DRAIN supply voltage = 15 V, starting junction temperature (T<sub>JS</sub>) = 25°C, L = 1.5 H, I<sub>AS</sub> = 200 mA (see [Figure 11](#)).

### 6.2 ESD Ratings

		VALUE	UNIT
V <sub>(ESD)</sub>	Electrostatic discharge Human body model (HBM), per ANSI/ESDA/JEDEC JS-001, all pins <sup>(1)</sup>	±2500	V

- (1) JEDEC document JEP155 states that 500-V HBM allows safe manufacturing with a standard ESD control process.

### 6.3 Recommended Operating Conditions

over operating free-air temperature range (unless otherwise noted)

		MIN	NOM	MAX	UNIT
V <sub>CC</sub>	Logic supply voltage	4.5		5.5	V
V <sub>IH</sub>	High-level input voltage	0.85 V <sub>CC</sub>			V
V <sub>IL</sub>	Low-level input voltage			0.15 V <sub>CC</sub>	V
	Pulsed drain output current, T <sub>C</sub> = 25°C, V <sub>CC</sub> = 5 V, all outputs on <sup>(1)</sup> <sup>(2)</sup> (see <a href="#">Figure 7</a> )			250	mA
t <sub>su</sub>	Setup time, SER IN high before SRCKM ↑ (see <a href="#">Figure 9</a> )	15			ns
t <sub>h</sub>	Hold time, SER IN high after SRCKM ↑, (see <a href="#">Figure 9</a> )	15			ns
t <sub>w</sub>	Pulse duration (see <a href="#">Figure 9</a> )	40			ns
T <sub>C</sub>	Operating case temperature	–40		125	°C

- (1) Pulse duration ≤ 100 μs and duty cycle ≤ 2%.
- (2) Technique should limit T<sub>J</sub> – T<sub>C</sub> to 10°C maximum.

## 6.4 Thermal Information

THERMAL METRIC <sup>(1)</sup>		TPIC6C596			UNIT
		PW (TSSOP)	D (SOIC)	N (PDIP)	
		16 PINS	16 PINS	16 PINS	
R <sub>θJA</sub>	Junction-to-ambient thermal resistance	109.7	83.7	51.5	°C/W
R <sub>θJC(top)</sub>	Junction-to-case (top) thermal resistance	44.6	45.1	38.3	
R <sub>θJB</sub>	Junction-to-board thermal resistance	54.8	41.2	31.4	
ψ <sub>JT</sub>	Junction-to-top characterization parameter	5	12.1	23.6	
ψ <sub>JB</sub>	Junction-to-board characterization parameter	54.2	40.9	31.3	

(1) For more information about traditional and new thermal metrics, see the *IC Package Thermal Metrics* application report, [SPRA953](#).

## 6.5 Electrical Characteristics

over operating free-air temperature range (unless otherwise noted)

PARAMETER		TEST CONDITIONS		MIN	TYP	MAX	UNIT
V <sub>(BR)DSX</sub>	Drain-to-source breakdown voltage	I <sub>D</sub> = 1 mA		33	37		V
V <sub>SD</sub>	Source-to-drain diode forward voltage	I <sub>F</sub> = 100 mA			0.85	1.2	V
V <sub>OH</sub>	High-level output voltage, SER OUT	I <sub>OH</sub> = -20 μA,	V <sub>CC</sub> = 4.5 V	4.4	4.49		V
		I <sub>OH</sub> = -4 mA,	V <sub>CC</sub> = 4.5 V	4	4.2		
V <sub>OL</sub>	Low-level output voltage, SER OUT	I <sub>OL</sub> = 20 μA,	V <sub>CC</sub> = 4.5 V		0.005	0.1	V
		I <sub>OL</sub> = 4 mA,	V <sub>CC</sub> = 4.5 V		0.3	0.5	
I <sub>IH</sub>	High-level input current	V <sub>CC</sub> = 5.5 V,	V <sub>I</sub> = V <sub>CC</sub>			1	μA
I <sub>IL</sub>	Low-level input current	V <sub>CC</sub> = 5.5 V,	V <sub>I</sub> = 0			-1	μA
I <sub>CC</sub>	Logic supply current	V <sub>CC</sub> = 5.5 V	All outputs off		20	200	μA
			All outputs on		150	500	
I <sub>CC(FRQ)</sub>	Logic supply current at frequency	f <sub>SRCK</sub> = 5 MHz, All outputs off,	C <sub>L</sub> = 30 pF, See <a href="#">Figure 9</a> and <a href="#">Figure 2</a>		1.2	5	mA
I <sub>N</sub>	Nominal current	V <sub>DS(on)</sub> = 0.5 V, T <sub>C</sub> = 85°C	I <sub>N</sub> = I <sub>D</sub> , See <sup>(1)</sup> ( <sup>2</sup> )( <sup>3</sup> )		90		mA
I <sub>DSX</sub>	OFF-state drain current	V <sub>DS</sub> = 30 V,	V <sub>CC</sub> = 5.5 V		0.1	0.2	μA
		V <sub>DS</sub> = 30 V T <sub>C</sub> = 125°C	V <sub>CC</sub> = 5.5 V		0.15	0.3	
r <sub>DS(on)</sub>	Static drain-source ON-state resistance	I <sub>D</sub> = 50 mA, V <sub>CC</sub> = 4.5 V	See <sup>(1)</sup> and <sup>(2)</sup> and <a href="#">Figure 3</a> and <a href="#">Figure 4</a>		6.5	9	Ω
		I <sub>D</sub> = 50 mA, T <sub>C</sub> = 125°C, V <sub>CC</sub> = 4.5 V			9.9	12	
		I <sub>D</sub> = 100 mA, V <sub>CC</sub> = 4.5 V			9.9	10	

(1) Technique should limit T<sub>J</sub> - T<sub>C</sub> to 10°C maximum.

(2) These parameters are measured with voltage-sensing contacts separate from the current-carrying contacts.

(3) Nominal current is defined for a consistent comparison between devices from different sources. It is the current that produces a voltage drop of 0.5 V at T<sub>C</sub> = 85°C.

## 6.6 Switching Characteristics

 $V_{CC} = 5\text{ V}$ ,  $T_C = 25^\circ\text{C}$ 

PARAMETER		TEST CONDITIONS	MIN	TYP	MAX	UNIT
$t_{PLH}$	Propagation delay time, low-to-high-level output from $\overline{G}$	$C_L = 30\text{ pF}$ , $I_D = 75\text{ mA}$ , See <a href="#">Figure 5</a> , <a href="#">Figure 8</a> and <a href="#">Figure 9</a>		80		ns
$t_{PHL}$	Propagation delay time, high-to-low-level output from $\overline{G}$			50		ns
$t_r$	Rise time, drain output			100		ns
$t_f$	Fall time, drain output			80		ns
$t_{pd}$	Propagation delay time, SRCK $\downarrow$ to SEROUT	$C_L = 30\text{ pF}$ , $I_D = 75\text{ mA}$ , See <a href="#">Figure 9</a>		15		ns
$f_{(SRCK)}$	Serial clock frequency	$C_L = 30\text{ pF}$ , $I_D = 75\text{ mA}^{(1)}$			10	MHz
$t_a$	Reverse-recovery-current rise time	$I_F = 100\text{ mA}$ , $di/dt = 10\text{ A}/\mu\text{s}^{(2) (3)}$ , See <a href="#">Figure 10</a>		100		ns
$t_{rr}$	Reverse-recovery time			120		

- (1) This is the maximum serial clock frequency assuming cascaded operation where serial data is passed from one stage to a second stage. The clock period allows for SRCK  $\rightarrow$  SEROUT propagation delay and setup time plus some timing margin.
- (2) Technique should limit  $T_J - T_C$  to  $10^\circ\text{C}$  maximum.
- (3) These parameters are measured with voltage-sensing contacts separate from the current-carrying contacts.

### 6.7 Typical Characteristics

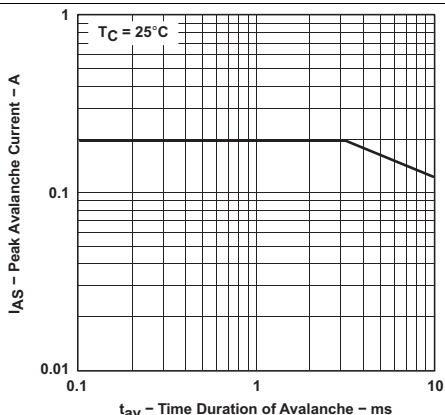

Figure 1. Peak Avalanche Current vs Time Duration of Avalanche

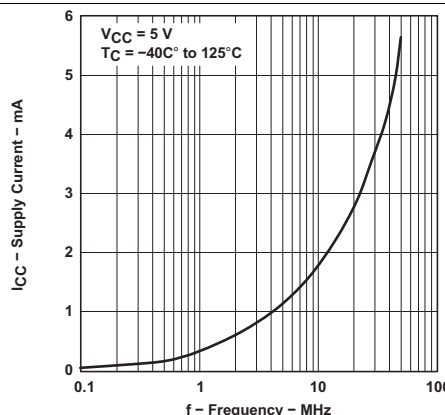
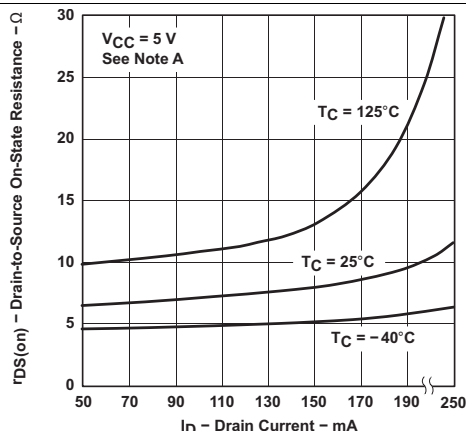

Figure 2. Supply Current vs Frequency



Technique should limit  $T_J - T_C$  to 10°C maximum.

Figure 3. Drain-to-Source ON-State Resistance vs Drain Current

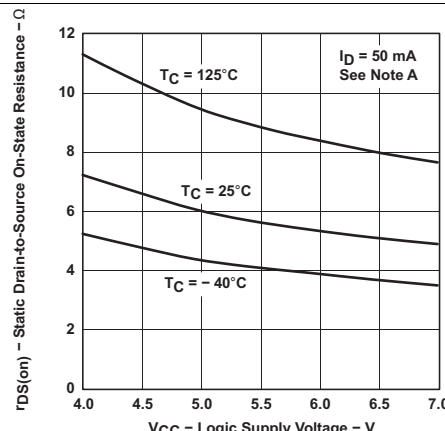
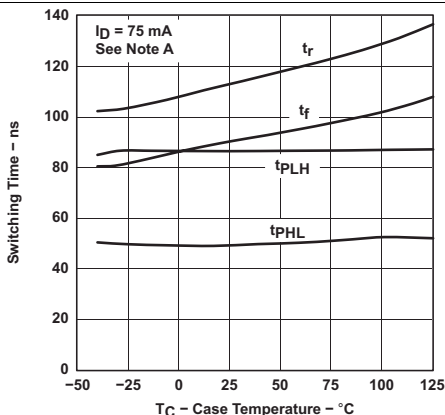

Figure 4. Static Drain-to-Source ON-State Resistance vs Logic Supply Voltage



Technique should limit  $T_J - T_C$  to 10°C maximum

Figure 5. Switching Time vs Case Temperature

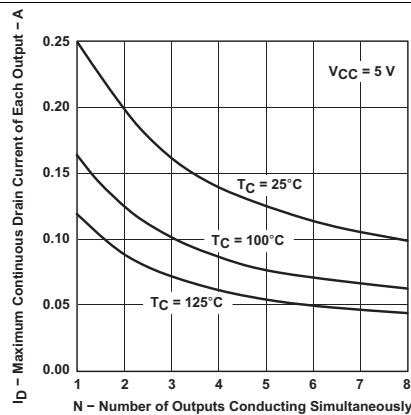
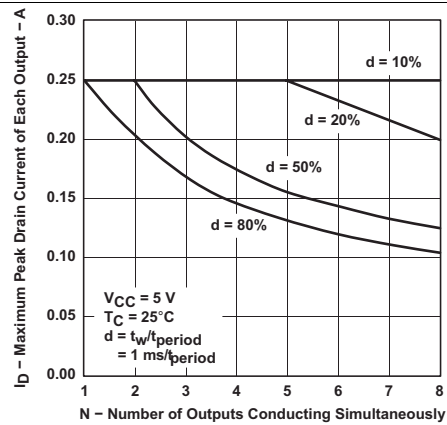
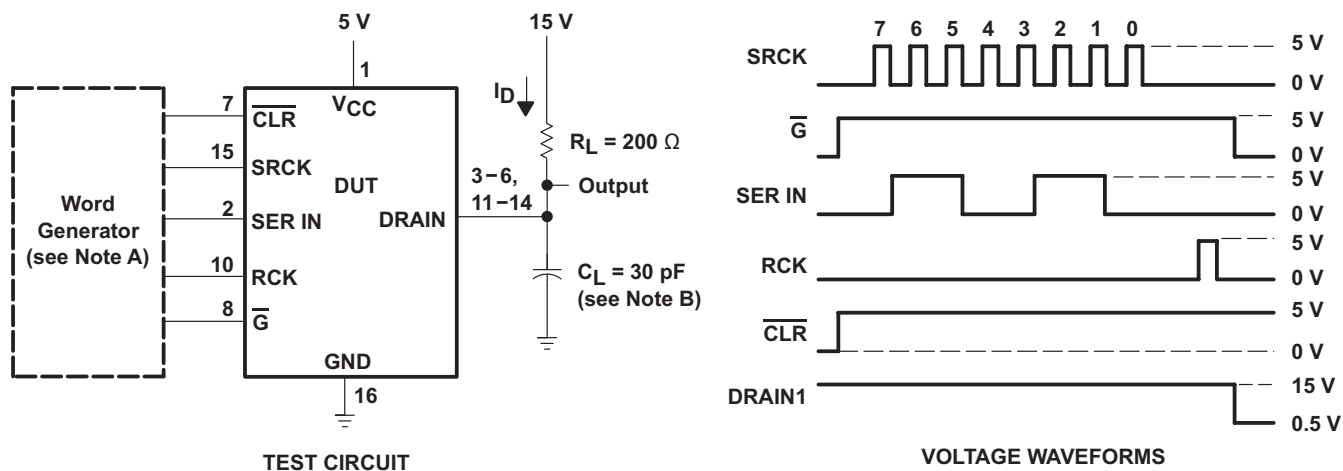

Figure 6. Maximum Continuous Drain Current of Each Output vs Number of Outputs Conducting Simultaneously

**Typical Characteristics (continued)**

**Figure 7. Maximum Peak Drain Current of Each Output vs Number of Outputs Conducting Simultaneously**

## 7 Parameter Measurement Information



- NOTES: A. The word generator has the following characteristics:  $t_r \leq 10\ \text{ns}$ ,  $t_f \leq 10\ \text{ns}$ ,  $t_w = 300\ \text{ns}$ , pulsed repetition rate (PRR) = 5 kHz,  $Z_O = 50\ \Omega$ .  
 B.  $C_L$  includes probe and jig capacitance.

**Figure 8. Resistive-Load Test Circuit and Voltage Waveforms**

Parameter Measurement Information (continued)

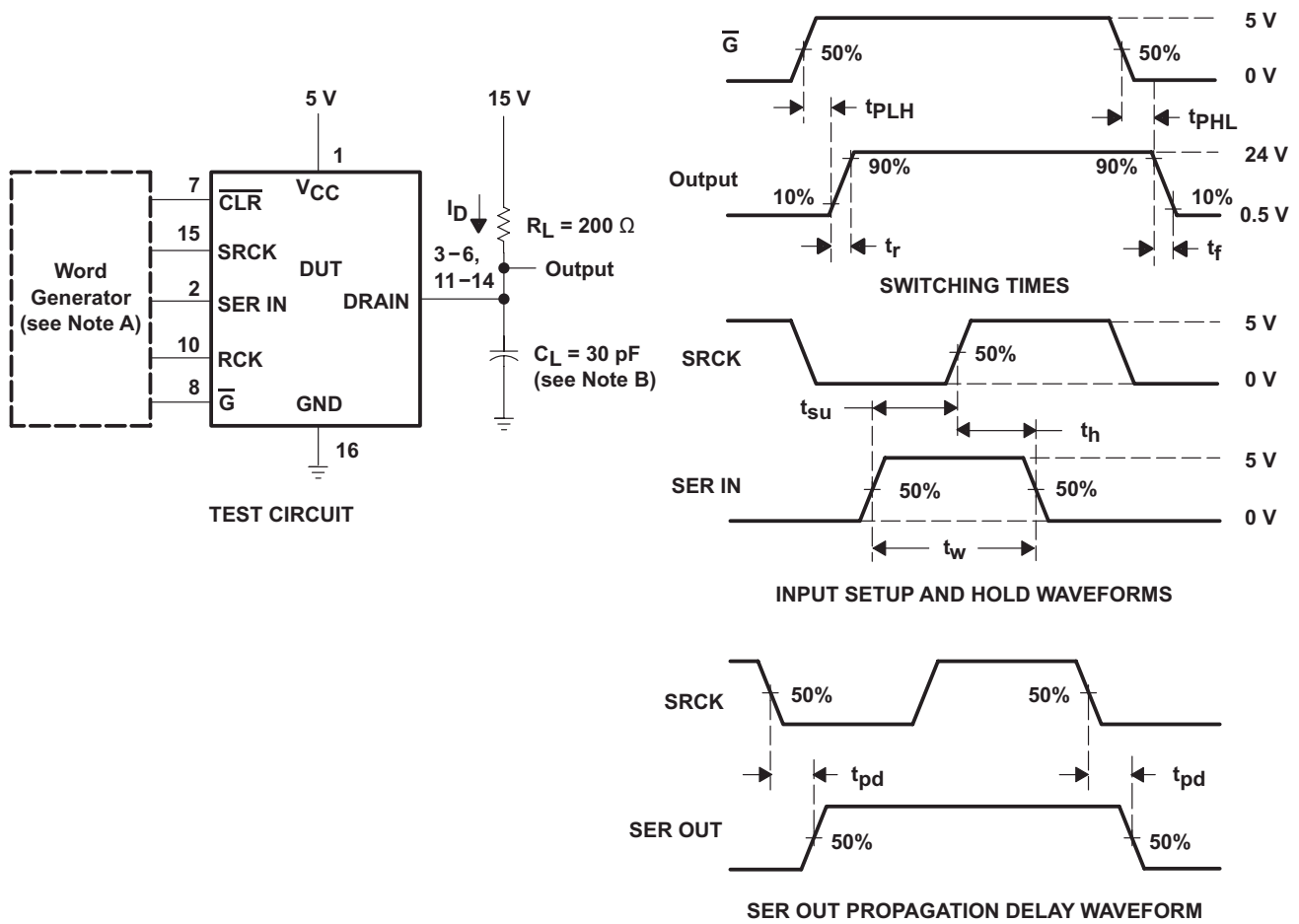

- NOTES: A. The word generator has the following characteristics: t<sub>r</sub> ≤ 10 ns, t<sub>f</sub> ≤ 10 ns, t<sub>w</sub> = 300 ns, pulsed repetition rate (PRR) = 5 kHz, Z<sub>O</sub> = 50  $\Omega$ .  
 B. C<sub>L</sub> includes probe and jig capacitance.

Figure 9. Test Circuit, Switching Times, and Voltage Waveforms

Parameter Measurement Information (continued)

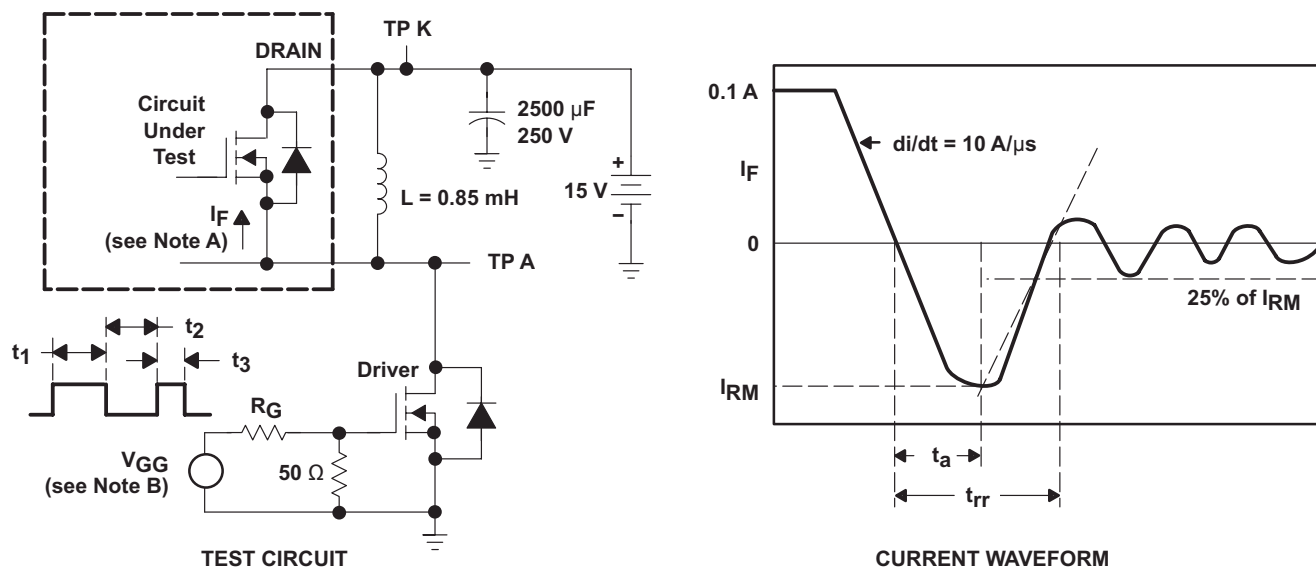
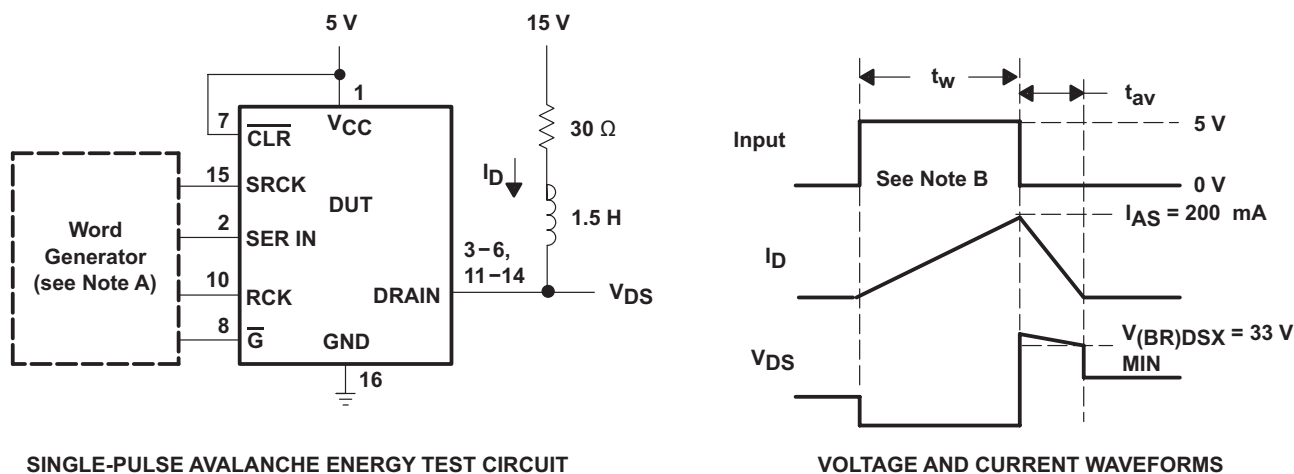

Figure 10. Reverse-Recovery-Current Test Circuit and Waveforms of Source-to-Drain Diode



- NOTES: A. The word generator has the following characteristics:  $t_r \leq 10$  ns,  $t_f \leq 10$  ns,  $Z_O = 50$  Ω.  
 B. Input pulse duration,  $t_w$ , is increased until peak current  $I_{AS} = 200$  mA.  
 Energy test level is defined as  $E_{AS} = I_{AS} \times V_{(BR)DSX} \times t_{av}/2 = 30$  mJ.

Figure 11. Single-Pulse Avalanche Energy Test Circuit and Waveforms

## 8 Detailed Description

### 8.1 Overview

The TPIC6C596 device is a monolithic, medium-voltage, low-current 8-bit shift register designed to drive relatively moderate load power such as LEDs. The device contains a built-in voltage clamp on the outputs for inductive transient protection, so it can also drive relays, solenoids, and other low-current or medium-voltage loads.

### 8.2 Functional Block Diagram

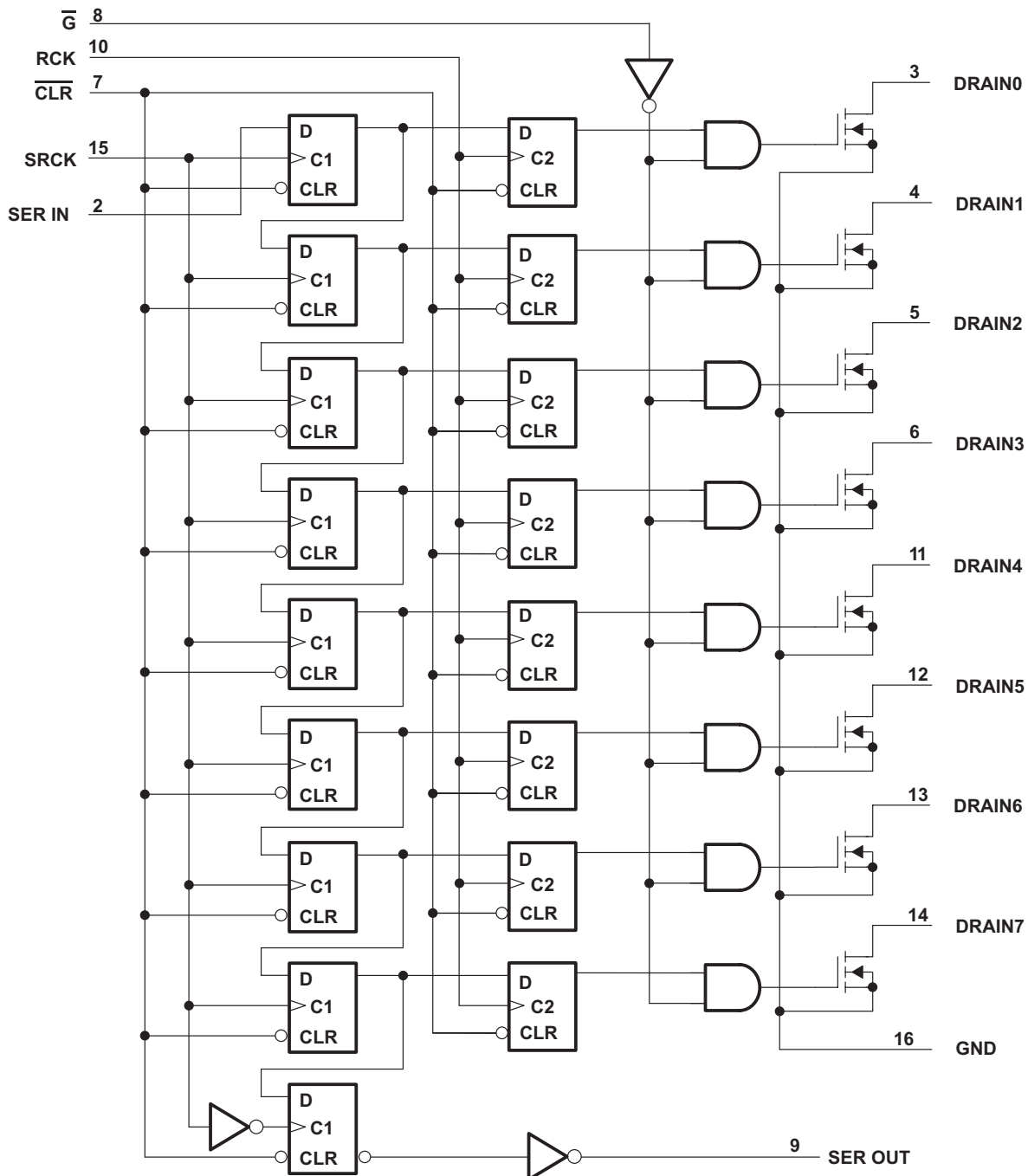

**Figure 12. Logic Diagram (Positive Logic)**

## 8.3 Feature Description

### 8.3.1 Serial-In Interface

The TPIC6C596 device contains an 8-bit serial-in, parallel-out shift register that feeds an 8-bit D-type storage register. Data transfers through both the shift and storage registers on the rising edge of the shift register clock (SRCK) and the register clock (RCK), respectively. The storage register transfers data to the output buffer when shift register clear (CLR) is high.

### 8.3.2 Clear Register

A logical low on  $\overline{\text{CLR}}$  clears all registers in the device. TI suggests clearing the device during power up or initialization.

### 8.3.3 Output Control

Holding the output enable ( $\overline{\text{G}}$ ) high holds all data in the output buffers low, and all drain outputs are off. Holding  $\overline{\text{G}}$  low makes data from the storage register transparent to the output buffers. When data in the output buffers is low, the DMOS transistor outputs are off. When data is high, the DMOS transistor outputs are capable of sink-current. This pin can also be used for global PWM dimming.

## 8.4 Device Functional Modes

### 8.4.1 Operation With $V(\text{VIN}) < 4.5 \text{ V}$ (Minimum $V(\text{VIN})$ )

This device works normally during  $4.5 \text{ V} \leq V(\text{VIN}) \leq 5.5 \text{ V}$ , when operation voltage is lower than 4.5 V. The behavior of device can't be ensured, including communication interface and current capability.

### 8.4.2 Operating With $5.5 \text{ V} < V(\text{VIN}) < 6 \text{ V}$

This device works normally during this voltage range, but reliability issues may occur while the device works for a long time in this voltage range.

## 9 Application and Implementation

### NOTE

Information in the following applications sections is not part of the TI component specification, and TI does not warrant its accuracy or completeness. TI's customers are responsible for determining suitability of components for their purposes. Customers should validate and test their design implementation to confirm system functionality.

### 9.1 Application Information

The TPIC6C596 device is a serial-in parallel-out, Power+LogicE 8-bit shift register with low-side switch DMOS outputs rating of a 100 mA per channel. The device is designed to drive resistive and inductive loads and is particularly well-suited as an interface between a microcontroller and LEDs or lamps. The TPIC6C596 device is an enhancement of the TPIC6C595 device, where the shift register serial output (SER OUT) is clocked on the falling edge of the serial clock to provide additional hold-time in applications where several devices are cascaded.

#### 9.1.1 Cascaded Application

The serial output (SEROUT) clocks out of the device on the falling edge of SRCK to provide additional hold time for cascaded applications. Connect the device (SEROUT) pin to the next device (SERIN) for daisy Chain. This provides improved performance for applications where clock signals may be skewed, devices are not located near one another, or the system must tolerate electromagnetic interference.

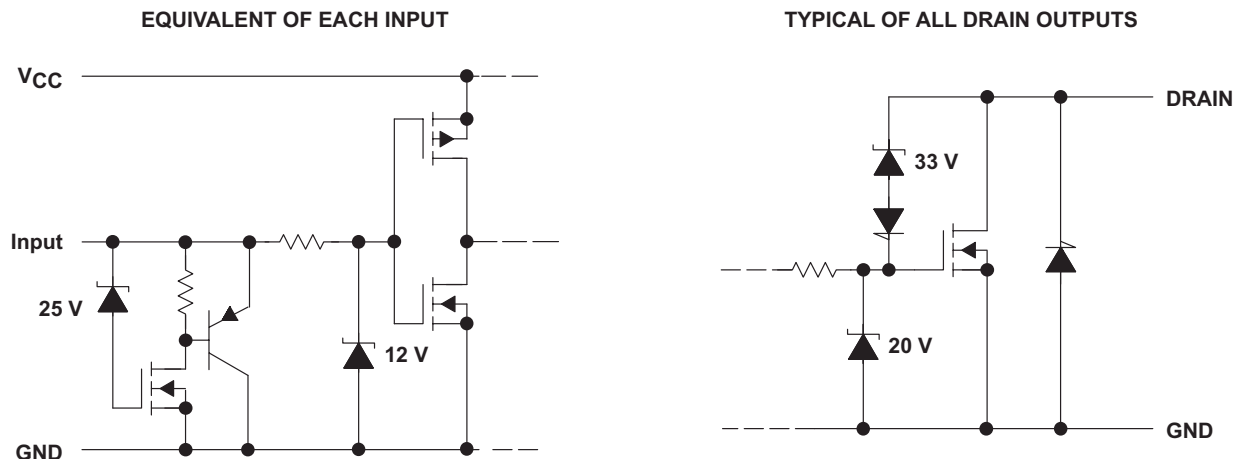

Figure 13. Schematic of Inputs and Outputs

### 9.2 Typical Application

The typical application of TPIC6C596 device is an automotive cluster driver. In this example, two TPIC6C596 power shift registers are cascaded and used to turn on LEDs in the cluster panel. In this case, the LED must be updated after all 16 bits of data have been loaded into the serial shift registers. The MCU outputs the data to the serial input (SER IN) while clocking the shift register clock (SRCK). After the 16th clock, a pulse to the register clock (RCK) transfers the data to the storage registers. If output enable ( $\bar{G}$ ) is low, then the LEDs are turned on corresponding to the status word with ones being on and zeros off. With this simple scheme, MCU can use the SPI interface to turn on 16 LEDs using only two ICs as illustrated in [Figure 14](#).

Typical Application (continued)

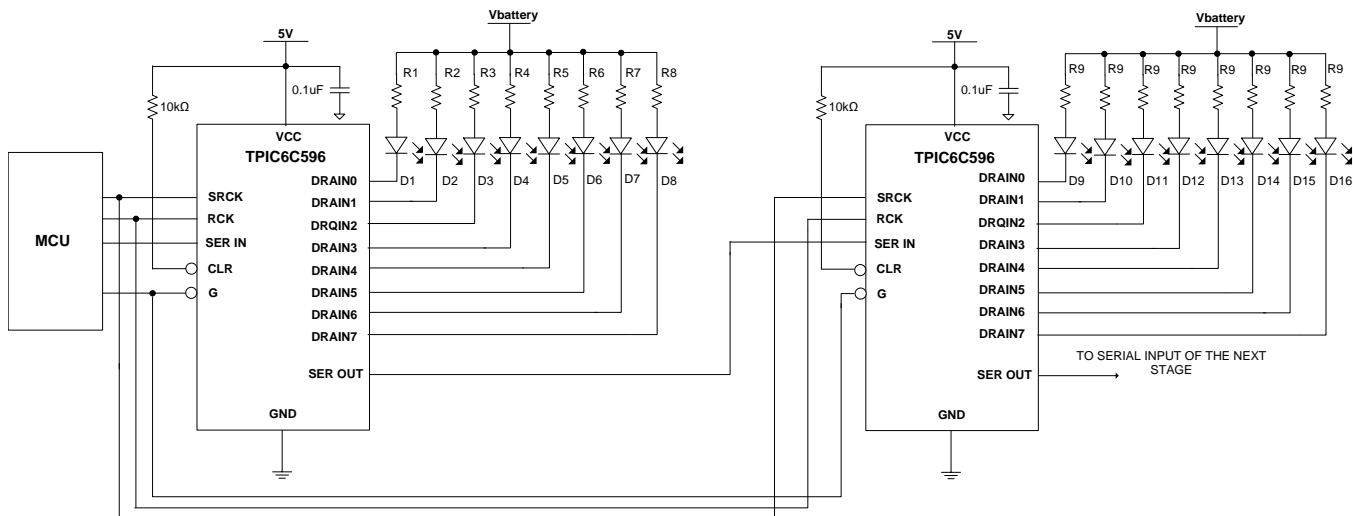

Figure 14. Typical Application Schematic

9.2.1 Design Requirements

Table 1 lists the design parameters for Figure 14.

Table 1. Design Parameters

DESIGN PARAMETER	EXAMPLE VALUE
Vsupply	9 to 16 V
V (D1), V (D2), V (D3), V (D4), V (D5), V (D6), V (D7), V (D8)	2 V
V (D9), V (D10), V (D11), V (D12), V (D13), V (D14), V (D15), V (D16)	3.3 V
I (D1), I (D2), I (D3), I (D4), I (D5), I (D6), I (D7), I (D8)	20 mA when Vbattery is 12 V
I (D9), I (D10), I (D11), I (D12), I (D13), I (D14), I (D15), I (D16)	30 mA when Vbattery is 12 V

9.2.2 Detailed Design Procedure

To begin the design process, the designer must decide on a few parameters. The designer must know the following:

- Vsupply: LED supply is connected directly to the car battery, which has a voltage range from 9 V to 16 V, or fixed voltage. This application connects to the battery directly.
- V(Dx): LED forward voltage
- I(Dx): LED setting current when battery is 12 V.

9.2.2.1 R1, R2, R3, R4, R5, R6, R7, R8  $R1 = R2 = R3 = R4 = R5 = R6 = R7 = R8 = (V_{supply} - V(Dx)) / I(Dx) = (12 V - 2 V) / 0.02 A = 500 \Omega$

When Vsupply is 9 V, I (D1) = I (D2) = I (D3) = I (D4) = I (D5) = I (D6) = I (D7) = I (D8) = (Vsupply – V(Dx)) / Rx = 14 mA.

When Vsupply is 16 V, I (D9) = I (D10) = I (D11) = I (D12) = I (D13) = I (D14) = I (D15) = I (D16) = (Vsupply – V(Dx)) / Rx = 43.8 mA.

**NOTE**

If designers can accept the current variation when battery voltage is changing, they can connect the device directly to the battery. If a designer need the less variation of current, they need to use the voltage regulator as supply voltage of LED, or change to constant current LED driver directly

**9.2.3 Application Curve**

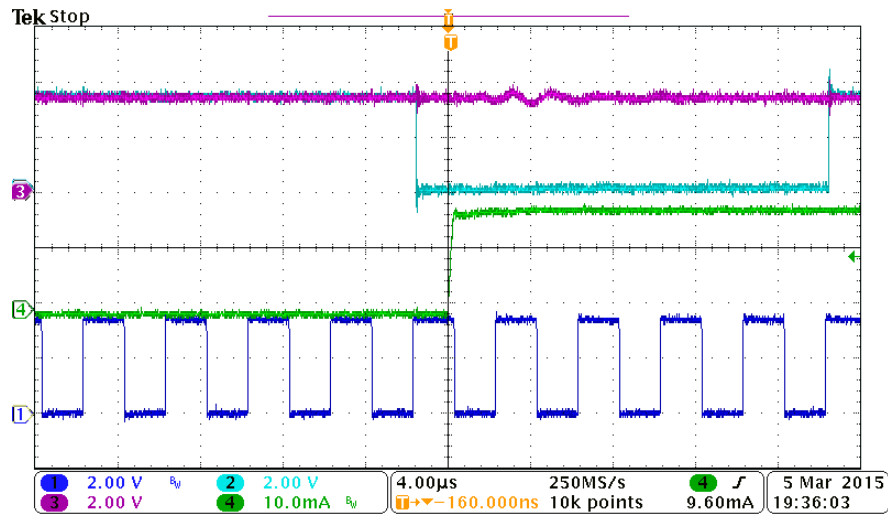

**Figure 15. CH1 is SRCK, CH2 is RCK, CH3 is SER IN and CH4 is D1 Current**

## 10 Power Supply Recommendations

The TPIC6C596 device is designed to operate from an input voltage supply range from 4.5 V and 5.5 V. This input supply should be well regulated. TI recommends placing the ceramic bypass capacitors near the VCC pin.

## 11 Layout

### 11.1 Layout Guidelines

There is no special layout requirement for the digital signal pin; the only requirement is placing the ceramic bypass capacitors near the corresponding pin. Because the TPIC6C596 device does not have a thermal shutdown protection function, to prevent thermal damage,  $T_J$  must be less than 150°C. If the total sink current is high, the power dissipation might be large. The devices are currently not available in the thermal pad package, so good PCB design can optimize heat transfer, which is absolutely essential for the long-term reliability of the device.

Maximize the copper coverage on the PCB to increase the thermal conductivity of the board, because the major heat-flow path from the package to the ambient is through the copper on the PCB. Maximum copper is extremely important when the design does not include heat sinks attached to the PCB on the other side of the package.

- Add as many thermal vias as possible directly under the package ground pad to optimize the thermal conductivity of the board.
- All thermal vias should be either plated shut or plugged and capped on both sides of the board to prevent solder voids. To ensure reliability and performance, the solder coverage should be at least 85%.

**TPIC6C596**

SLIS093D – MARCH 2000 – REVISED MARCH 2015

www.ti.com

**11.2 Layout Example**

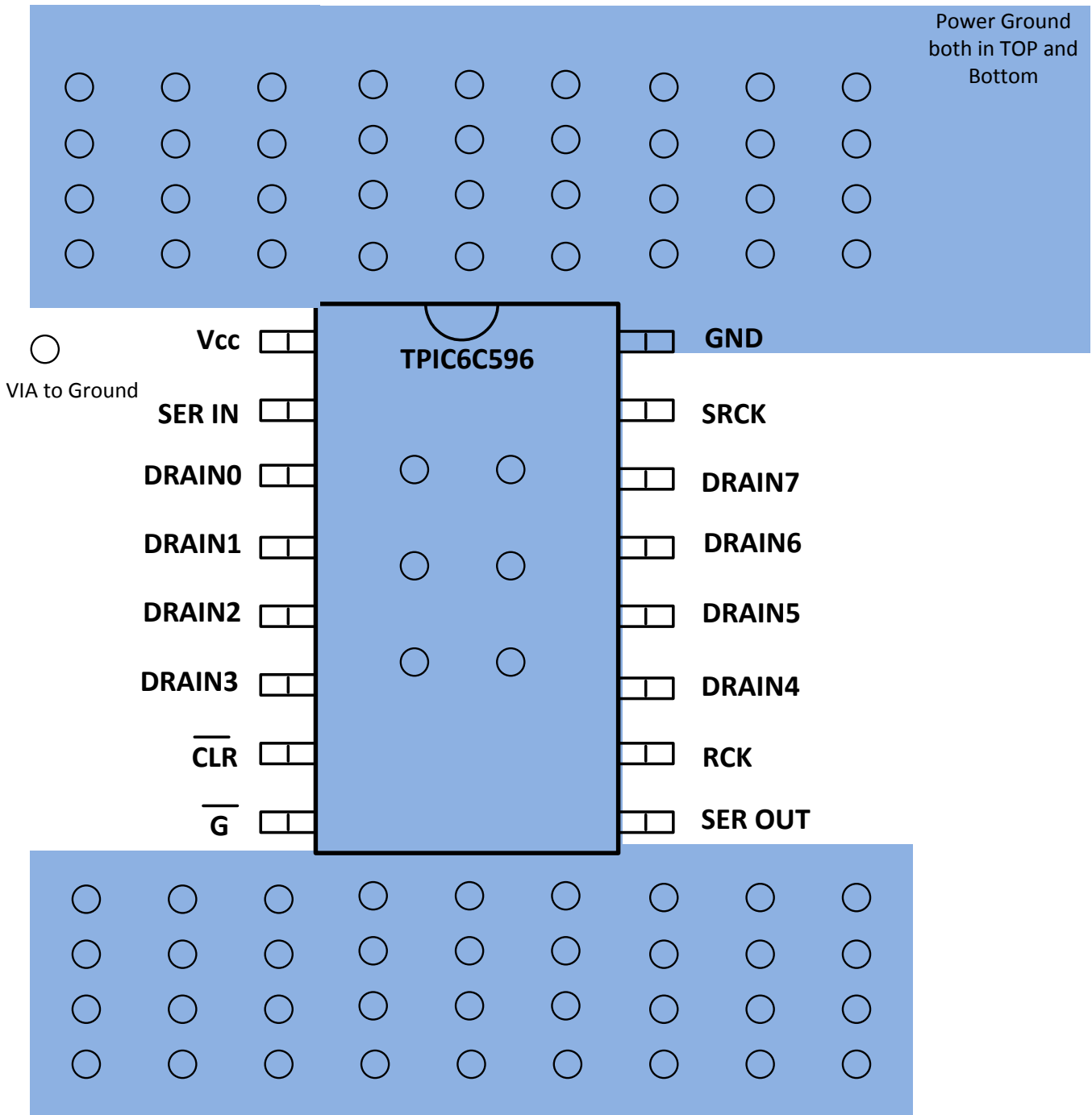

**Figure 16. Recommended Layout Example**

### 11.3 Thermal Considerations

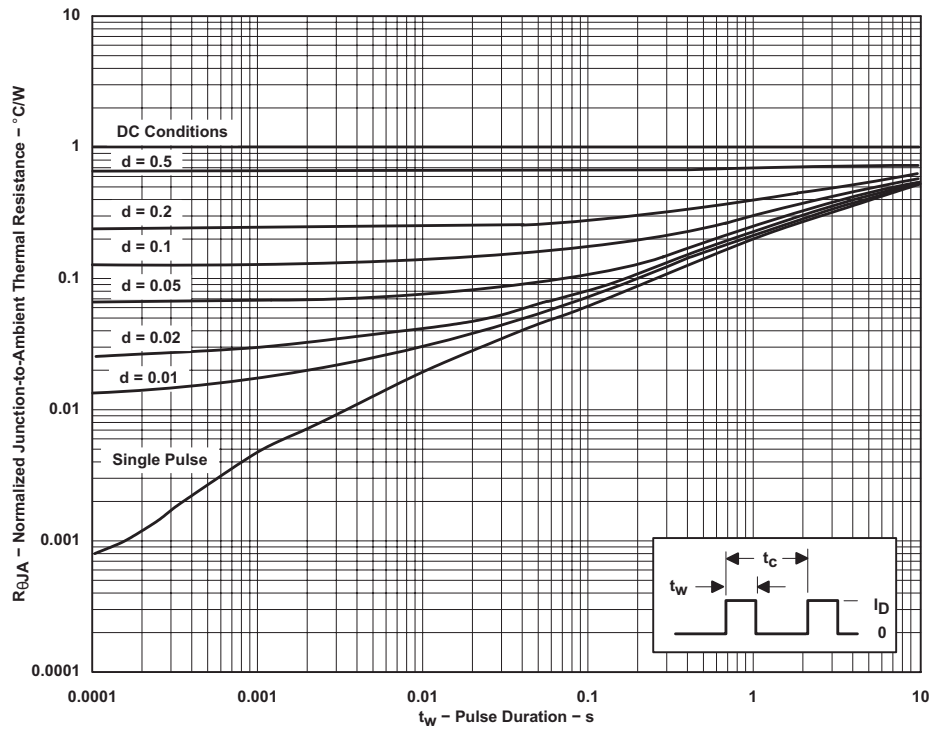

† Device mounted on FR4 printed-circuit board with no heat sink

NOTES:  $Z_{\theta A}(t) = r(t) R_{\theta JA}$   
 $t_w$  = pulse duration  
 $t_c$  = cycle time  
 $d$  = duty cycle =  $t_w/t_c$

Figure 17. D Package†, Normalized Junction-to-Ambient Thermal Resistance vs Pulse Duration

## 12 Device and Documentation Support

### 12.1 Trademarks

All trademarks are the property of their respective owners.

### 12.2 Electrostatic Discharge Caution



These devices have limited built-in ESD protection. The leads should be shorted together or the device placed in conductive foam during storage or handling to prevent electrostatic damage to the MOS gates.

### 12.3 Glossary

[SLYZ022](#) — *TI Glossary*.

This glossary lists and explains terms, acronyms, and definitions.

## 13 Mechanical, Packaging, and Orderable Information

The following pages include mechanical, packaging, and orderable information. This information is the most current data available for the designated devices. This data is subject to change without notice and revision of this document. For browser-based versions of this data sheet, refer to the left-hand navigation.

**PACKAGING INFORMATION**

Orderable Device	Status (1)	Package Type	Package Drawing	Pins	Package Qty	Eco Plan (2)	Lead/Ball Finish (6)	MSL Peak Temp (3)	Op Temp (°C)	Device Marking (4/5)	Samples
TPIC6C596D	ACTIVE	SOIC	D	16	40	Green (RoHS & no Sb/Br)	CU NIPDAU	Level-1-260C-UNLIM	-40 to 125	TPIC6C596	<a href="#">Samples</a>
TPIC6C596DG4	ACTIVE	SOIC	D	16	40	Green (RoHS & no Sb/Br)	CU NIPDAU	Level-1-260C-UNLIM	-40 to 125	6C596	<a href="#">Samples</a>
TPIC6C596DR	ACTIVE	SOIC	D	16	2500	Green (RoHS & no Sb/Br)	CU NIPDAU	Level-1-260C-UNLIM	-40 to 125	TPIC6C596	<a href="#">Samples</a>
TPIC6C596DRG4	ACTIVE	SOIC	D	16	2500	Green (RoHS & no Sb/Br)	CU NIPDAU	Level-1-260C-UNLIM	-40 to 125	6C596	<a href="#">Samples</a>
TPIC6C596DRQ1	ACTIVE	SOIC	D	16	2500	Green (RoHS & no Sb/Br)	CU NIPDAU	Level-1-260C-UNLIM	-40 to 125	6C596Q	<a href="#">Samples</a>
TPIC6C596N	ACTIVE	PDIP	N	16	25	Pb-Free (RoHS)	CU NIPDAU	N / A for Pkg Type	-40 to 125	TPIC6C596	<a href="#">Samples</a>
TPIC6C596PW	ACTIVE	TSSOP	PW	16	90	Green (RoHS & no Sb/Br)	CU NIPDAU	Level-1-260C-UNLIM	-40 to 125	6C596PW	<a href="#">Samples</a>
TPIC6C596PWG4	ACTIVE	TSSOP	PW	16	90	Green (RoHS & no Sb/Br)	CU NIPDAU	Level-1-260C-UNLIM		6C596PW	<a href="#">Samples</a>
TPIC6C596PWR	ACTIVE	TSSOP	PW	16	2000	Green (RoHS & no Sb/Br)	CU NIPDAU	Level-1-260C-UNLIM	-40 to 125	6C596PW	<a href="#">Samples</a>
TPIC6C596PWRG4	ACTIVE	TSSOP	PW	16	2000	Green (RoHS & no Sb/Br)	CU NIPDAU	Level-1-260C-UNLIM		6C596PW	<a href="#">Samples</a>

(1) The marketing status values are defined as follows:

**ACTIVE:** Product device recommended for new designs.

**LIFEBUY:** TI has announced that the device will be discontinued, and a lifetime-buy period is in effect.

**NRND:** Not recommended for new designs. Device is in production to support existing customers, but TI does not recommend using this part in a new design.

**PREVIEW:** Device has been announced but is not in production. Samples may or may not be available.

**OBSOLETE:** TI has discontinued the production of the device.

(2) Eco Plan - The planned eco-friendly classification: Pb-Free (RoHS), Pb-Free (RoHS Exempt), or Green (RoHS & no Sb/Br) - please check <http://www.ti.com/productcontent> for the latest availability information and additional product content details.

**TBD:** The Pb-Free/Green conversion plan has not been defined.

**Pb-Free (RoHS):** TI's terms "Lead-Free" or "Pb-Free" mean semiconductor products that are compatible with the current RoHS requirements for all 6 substances, including the requirement that lead not exceed 0.1% by weight in homogeneous materials. Where designed to be soldered at high temperatures, TI Pb-Free products are suitable for use in specified lead-free processes.

**Pb-Free (RoHS Exempt):** This component has a RoHS exemption for either 1) lead-based flip-chip solder bumps used between the die and package, or 2) lead-based die adhesive used between the die and leadframe. The component is otherwise considered Pb-Free (RoHS compatible) as defined above.

**Green (RoHS & no Sb/Br):** TI defines "Green" to mean Pb-Free (RoHS compatible), and free of Bromine (Br) and Antimony (Sb) based flame retardants (Br or Sb do not exceed 0.1% by weight in homogeneous material)

- (3) MSL, Peak Temp. - The Moisture Sensitivity Level rating according to the JEDEC industry standard classifications, and peak solder temperature.
- (4) There may be additional marking, which relates to the logo, the lot trace code information, or the environmental category on the device.
- (5) Multiple Device Markings will be inside parentheses. Only one Device Marking contained in parentheses and separated by a "~" will appear on a device. If a line is indented then it is a continuation of the previous line and the two combined represent the entire Device Marking for that device.
- (6) Lead/Ball Finish - Orderable Devices may have multiple material finish options. Finish options are separated by a vertical ruled line. Lead/Ball Finish values may wrap to two lines if the finish value exceeds the maximum column width.

**Important Information and Disclaimer:**The information provided on this page represents TI's knowledge and belief as of the date that it is provided. TI bases its knowledge and belief on information provided by third parties, and makes no representation or warranty as to the accuracy of such information. Efforts are underway to better integrate information from third parties. TI has taken and continues to take reasonable steps to provide representative and accurate information but may not have conducted destructive testing or chemical analysis on incoming materials and chemicals. TI and TI suppliers consider certain information to be proprietary, and thus CAS numbers and other limited information may not be available for release.

In no event shall TI's liability arising out of such information exceed the total purchase price of the TI part(s) at issue in this document sold by TI to Customer on an annual basis.

**TAPE AND REEL INFORMATION**

**QUADRANT ASSIGNMENTS FOR PIN 1 ORIENTATION IN TAPE**

\*All dimensions are nominal

Device	Package Type	Package Drawing	Pins	SPQ	Reel Diameter (mm)	Reel Width W1 (mm)	A0 (mm)	B0 (mm)	K0 (mm)	P1 (mm)	W (mm)	Pin1 Quadrant
TPIC6C596DR	SOIC	D	16	2500	330.0	16.4	6.5	10.3	2.1	8.0	16.0	Q1
TPIC6C596DR	SOIC	D	16	2500	330.0	16.4	6.5	10.3	2.1	8.0	16.0	Q1
TPIC6C596DRG4	SOIC	D	16	2500	330.0	16.4	6.5	10.3	2.1	8.0	16.0	Q1
TPIC6C596DRQ1	SOIC	D	16	2500	330.0	16.4	6.5	10.3	2.1	8.0	16.0	Q1
TPIC6C596PWR	TSSOP	PW	16	2000	330.0	12.4	6.9	5.6	1.6	8.0	12.0	Q1
TPIC6C596PWRG4	TSSOP	PW	16	2000	330.0	12.4	6.9	5.6	1.6	8.0	12.0	Q1

**TAPE AND REEL BOX DIMENSIONS**

\*All dimensions are nominal

Device	Package Type	Package Drawing	Pins	SPQ	Length (mm)	Width (mm)	Height (mm)
TPIC6C596DR	SOIC	D	16	2500	367.0	367.0	38.0
TPIC6C596DR	SOIC	D	16	2500	367.0	367.0	38.0
TPIC6C596DRG4	SOIC	D	16	2500	367.0	367.0	38.0
TPIC6C596DRQ1	SOIC	D	16	2500	367.0	367.0	38.0
TPIC6C596PWR	TSSOP	PW	16	2000	367.0	367.0	35.0
TPIC6C596PWRG4	TSSOP	PW	16	2000	367.0	367.0	35.0

N (R-PDIP-T\*\*)

PLASTIC DUAL-IN-LINE PACKAGE

16 PINS SHOWN



- NOTES:
- A. All linear dimensions are in inches (millimeters).
  - B. This drawing is subject to change without notice.
  - Falls within JEDEC MS-001, except 18 and 20 pin minimum body length (Dim A).
  - The 20 pin end lead shoulder width is a vendor option, either half or full width.



D (R-PDSO-G16)

PLASTIC SMALL OUTLINE



- NOTES:
- All linear dimensions are in millimeters.
  - This drawing is subject to change without notice.
  - Publication IPC-7351 is recommended for alternate designs.
  - Laser cutting apertures with trapezoidal walls and also rounding corners will offer better paste release. Customers should contact their board assembly site for stencil design recommendations. Refer to IPC-7525 for other stencil recommendations.
  - Customers should contact their board fabrication site for solder mask tolerances between and around signal pads.



PW (R-PDSO-G16)

PLASTIC SMALL OUTLINE

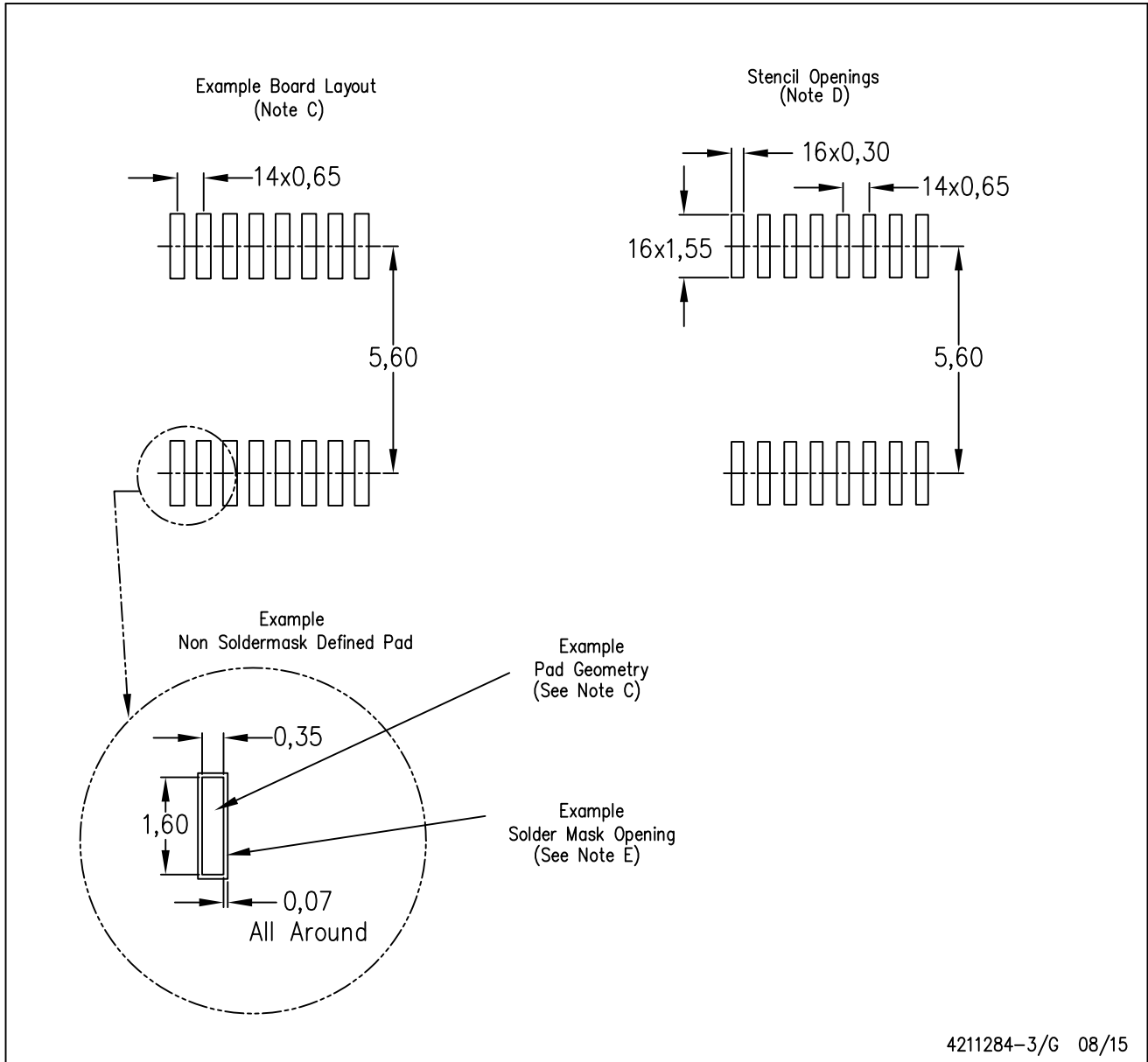

- NOTES:
- All linear dimensions are in millimeters.
  - This drawing is subject to change without notice.
  - Publication IPC-7351 is recommended for alternate designs.
  - Laser cutting apertures with trapezoidal walls and also rounding corners will offer better paste release. Customers should contact their board assembly site for stencil design recommendations. Refer to IPC-7525 for other stencil recommendations.
  - Customers should contact their board fabrication site for solder mask tolerances between and around signal pads.

## IMPORTANT NOTICE

Texas Instruments Incorporated and its subsidiaries (TI) reserve the right to make corrections, enhancements, improvements and other changes to its semiconductor products and services per JESD46, latest issue, and to discontinue any product or service per JESD48, latest issue. Buyers should obtain the latest relevant information before placing orders and should verify that such information is current and complete. All semiconductor products (also referred to herein as "components") are sold subject to TI's terms and conditions of sale supplied at the time of order acknowledgment.

TI warrants performance of its components to the specifications applicable at the time of sale, in accordance with the warranty in TI's terms and conditions of sale of semiconductor products. Testing and other quality control techniques are used to the extent TI deems necessary to support this warranty. Except where mandated by applicable law, testing of all parameters of each component is not necessarily performed.

TI assumes no liability for applications assistance or the design of Buyers' products. Buyers are responsible for their products and applications using TI components. To minimize the risks associated with Buyers' products and applications, Buyers should provide adequate design and operating safeguards.

TI does not warrant or represent that any license, either express or implied, is granted under any patent right, copyright, mask work right, or other intellectual property right relating to any combination, machine, or process in which TI components or services are used. Information published by TI regarding third-party products or services does not constitute a license to use such products or services or a warranty or endorsement thereof. Use of such information may require a license from a third party under the patents or other intellectual property of the third party, or a license from TI under the patents or other intellectual property of TI.

Reproduction of significant portions of TI information in TI data books or data sheets is permissible only if reproduction is without alteration and is accompanied by all associated warranties, conditions, limitations, and notices. TI is not responsible or liable for such altered documentation. Information of third parties may be subject to additional restrictions.

Resale of TI components or services with statements different from or beyond the parameters stated by TI for that component or service voids all express and any implied warranties for the associated TI component or service and is an unfair and deceptive business practice. TI is not responsible or liable for any such statements.

Buyer acknowledges and agrees that it is solely responsible for compliance with all legal, regulatory and safety-related requirements concerning its products, and any use of TI components in its applications, notwithstanding any applications-related information or support that may be provided by TI. Buyer represents and agrees that it has all the necessary expertise to create and implement safeguards which anticipate dangerous consequences of failures, monitor failures and their consequences, lessen the likelihood of failures that might cause harm and take appropriate remedial actions. Buyer will fully indemnify TI and its representatives against any damages arising out of the use of any TI components in safety-critical applications.

In some cases, TI components may be promoted specifically to facilitate safety-related applications. With such components, TI's goal is to help enable customers to design and create their own end-product solutions that meet applicable functional safety standards and requirements. Nonetheless, such components are subject to these terms.

No TI components are authorized for use in FDA Class III (or similar life-critical medical equipment) unless authorized officers of the parties have executed a special agreement specifically governing such use.

Only those TI components which TI has specifically designated as military grade or "enhanced plastic" are designed and intended for use in military/aerospace applications or environments. Buyer acknowledges and agrees that any military or aerospace use of TI components which have **not** been so designated is solely at the Buyer's risk, and that Buyer is solely responsible for compliance with all legal and regulatory requirements in connection with such use.

TI has specifically designated certain components as meeting ISO/TS16949 requirements, mainly for automotive use. In any case of use of non-designated products, TI will not be responsible for any failure to meet ISO/TS16949.

### Products

Audio	<a href="http://www.ti.com/audio">www.ti.com/audio</a>
Amplifiers	<a href="http://amplifier.ti.com">amplifier.ti.com</a>
Data Converters	<a href="http://dataconverter.ti.com">dataconverter.ti.com</a>
DLP® Products	<a href="http://www.dlp.com">www.dlp.com</a>
DSP	<a href="http://dsp.ti.com">dsp.ti.com</a>
Clocks and Timers	<a href="http://www.ti.com/clocks">www.ti.com/clocks</a>
Interface	<a href="http://interface.ti.com">interface.ti.com</a>
Logic	<a href="http://logic.ti.com">logic.ti.com</a>
Power Mgmt	<a href="http://power.ti.com">power.ti.com</a>
Microcontrollers	<a href="http://microcontroller.ti.com">microcontroller.ti.com</a>
RFID	<a href="http://www.ti-rfid.com">www.ti-rfid.com</a>
OMAP Applications Processors	<a href="http://www.ti.com/omap">www.ti.com/omap</a>
Wireless Connectivity	<a href="http://www.ti.com/wirelessconnectivity">www.ti.com/wirelessconnectivity</a>

### Applications

Automotive and Transportation	<a href="http://www.ti.com/automotive">www.ti.com/automotive</a>
Communications and Telecom	<a href="http://www.ti.com/communications">www.ti.com/communications</a>
Computers and Peripherals	<a href="http://www.ti.com/computers">www.ti.com/computers</a>
Consumer Electronics	<a href="http://www.ti.com/consumer-apps">www.ti.com/consumer-apps</a>
Energy and Lighting	<a href="http://www.ti.com/energy">www.ti.com/energy</a>
Industrial	<a href="http://www.ti.com/industrial">www.ti.com/industrial</a>
Medical	<a href="http://www.ti.com/medical">www.ti.com/medical</a>
Security	<a href="http://www.ti.com/security">www.ti.com/security</a>
Space, Avionics and Defense	<a href="http://www.ti.com/space-avionics-defense">www.ti.com/space-avionics-defense</a>
Video and Imaging	<a href="http://www.ti.com/video">www.ti.com/video</a>

### TI E2E Community

[e2e.ti.com](http://e2e.ti.com)