

## TPIC7218-Q1 Power Controller and Sensor ASIC For Braking Applications

### 1 Device Overview

#### 1.1 Features

- Qualified for Automotive Applications
- AEC-Q100 Qualified with the Following Results:
  - Device Temperature Grade 1:  $-40^{\circ}\text{C}$  to  $125^{\circ}\text{C}$  Ambient Operating Temperature Range
  - Device HBM ESD Classification Level 2
  - Device CDM ESD Classification Level C4
- PWM Low-Side Drivers
  - 4 PWM Low-Side Driver Outputs
  - Current Limitation
  - Thermal Protection:  $T_J = 185^{\circ}\text{C}$  (Minimum)
  - Open-Load Detection
  - Energy Capability: 30 mJ at  $T_J = 150^{\circ}\text{C}$
  - Clamp Voltage: 40 V
  - Low  $R_{DSon}$ : 0.3  $\Omega$  (Maximum) at  $T_J = 150^{\circ}\text{C}$
- Digital Low-Side Drivers
  - 4 Digital Low-Side Driver Outputs
  - Current Limitation
  - Thermal Protection:  $T_J = 185^{\circ}\text{C}$  (Minimum)
  - Open-Load Detection
  - Energy Capability: 50 mJ at  $T_J = 150^{\circ}\text{C}$
  - Clamp Voltage: 40 V
  - Low  $R_{DSon}$ : 0.2  $\Omega$  (Maximum) at  $T_J = 150^{\circ}\text{C}$
- Dual High-Side Power Drivers
  - Direct Input Control
  - PWM Capability
  - Load Dump (overvoltage) Detection
  - Programmable overcurrent detection
  - Load Leakage Detection
  - Programmable short-circuit Protection
  - Fault detection over SPI
- Wheel-Speed Sensor Interface
  - Compatible with Intelligent and Active Wheel-Speed Sensors
  - 4 High-Side Switches With Short-Circuit Protection
  - 4 Low-Side Switches With Short-Circuit Protection
  - 2 High Voltage Low-Side Output Drivers
  - 4 Digital Outputs to Indicate the Speed
  - Integrated Data Decoder for Intelligent Wheel-Speed Sensors
- Open-Drain Warning Lamp Drivers
  - 2 High Voltage Drivers
  - Thermal Protection With Hysteresis
  - Current Limitation
  - $T_J = 185^{\circ}\text{C}$  (Minimum)
  - $R_{DSon}$ : 4  $\Omega$  at  $T_J = 150^{\circ}\text{C}$
  - Clamp Voltage: 40 V
- Other Features
  - K-LINE Transceiver
  - 3.3-V or 5-V Compatible Digital IO
  - Internal 3.3-V Regulator
  - Internal Charge Pump
  - 1 Low-Voltage Open-Drain Warning Lamp Driver
  - Full Duplex SPI Interface
  - Watchdog Input With Open-Drain Fault Reporting for Safety
  - Pb-Free ASIC
  - Compliant With CISPR 25 NB Class 5 for Conducted and Radiated Emissions

#### 1.2 Applications

- Anti-lock Braking Systems (ABS)
- Electronic Stability Control Systems (ESC)

#### 1.3 Description

The TPIC7218-Q1 device integrates in single package several functions needed in ABS and ESC electronic control units (ECU). This integration coupled with the minimization of the external components saves valuable ECU board space.

The TPIC7218-Q1 device is an antilock braking controller capable of directly driving eight solenoid valves with internal high-current low-side drivers. Low-side drivers configured for digital control do not require external voltage clamps. The TPIC7218-Q1 device has gate drive capability for two high-side N-Channel MOSFETs that can be used to drive a pump motor and power to all solenoids. The TPIC7218-Q1 device provides a fault-tolerant interface for both Intelligent and Active wheel-speed sensors to an external microprocessor. The TPIC7218-Q1 device can be used with either 3.3- or 5-V microprocessors and uses a standard SPI (Serial-Peripheral Interface).



The TPIC7218-Q1 device has two internal open-drain warning lamp drivers that can be pulled up to battery voltage, as well as one low-voltage driver. An internal state machine monitors a watchdog input and reports faults on a warning-lamp pin and SPI register. A K-Line transceiver is also included. A multitude of safety and fault monitoring functionality supervise both system and TPIC7218-Q1 circuits. Faults must be polled and reset over SPI. The TPIC7218-Q1 device is designed for use in harsh automotive environments, capable of withstanding high operating temperatures and electrically noisy signals and power. Short-to-ground, short-to-battery, and open-load conditions are tolerated and monitored. The TPIC7218-Q1 device also exhibits outstanding Electro-Magnetic Compatibility (EMC) performance.

**Device Information<sup>(1)</sup>**

| PART NUMBER | PACKAGE    | BODY SIZE (NOM)     |
|-------------|------------|---------------------|
| TPIC7218-Q1 | HTQFP (80) | 12.00 mm x 12.00 mm |

(1) For all available packages, see the orderable addendum at the end of the data sheet.

### 1.4 Functional Block Diagram

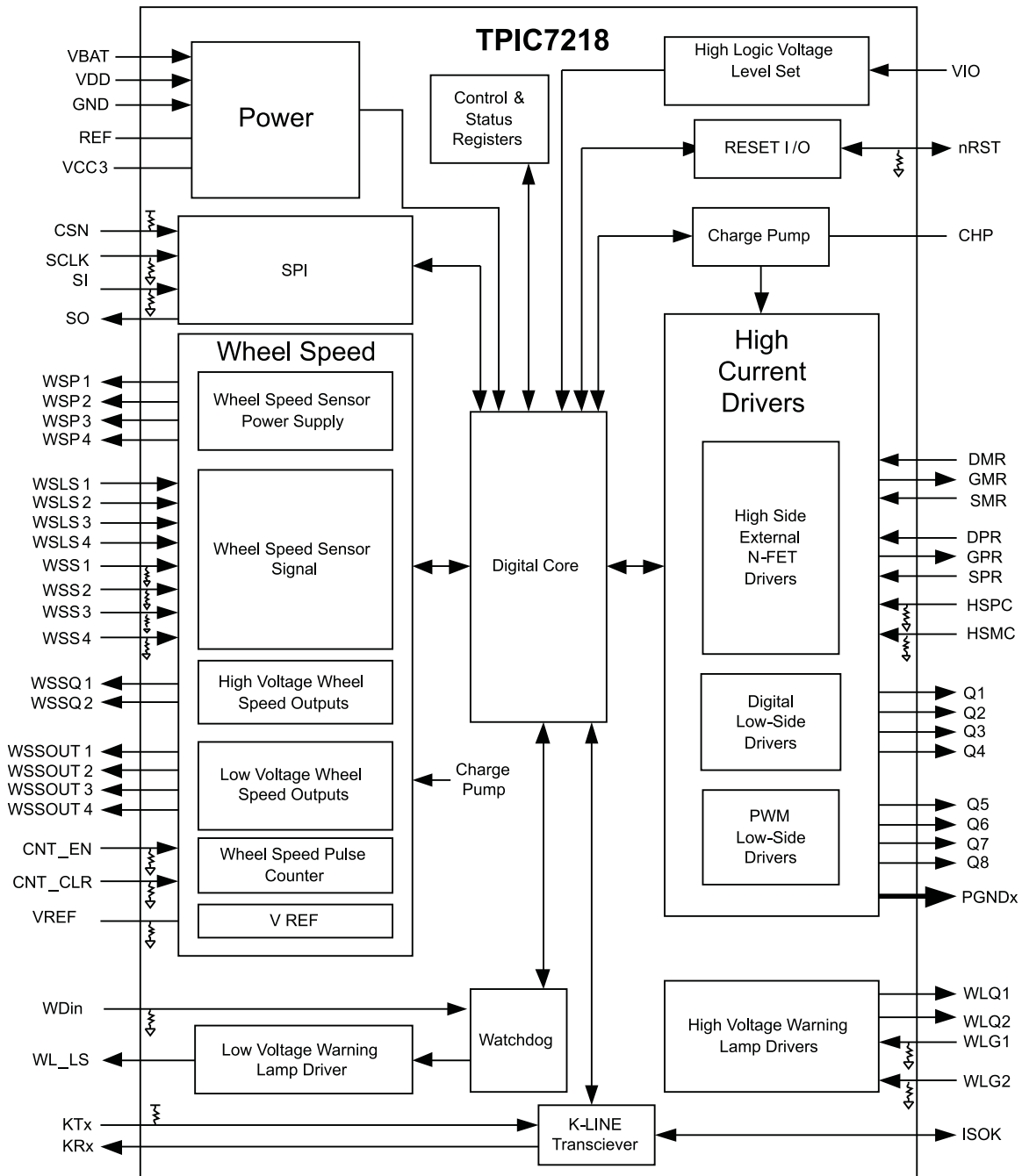

Figure 1-1. Functional Block Diagram

## Table of Contents

|          |  |          |           |   |           |
|----------|--|----------|-----------|---|-----------|
| <b>1</b> | <b>Device Overview</b>                                 | <b>1</b> | 4.23      | PWM Low-Side Driver Switching Characteristics ...           | <b>15</b> |
| 1.1      | Features   | 1        | 4.24      | K-Line Switching Characteristics                            | 15        |
| 1.2      | Applications   | 1        | 4.25      | Warning Lamp Switching Characteristics                      | 15        |
| 1.3      | Description  | 1        | 4.26      | Watchdog Switching Characteristics                          | 16        |
| 1.4      | Functional Block Diagram                               | 3        | 4.27      | Wheel Speed Interface Switching Characteristics ..          | 16        |
| <b>2</b> | <b>Revision History</b>                                | <b>4</b> | 4.28      | Wheel-Speed High-Side Driver Switching Characteristics..... | 16        |
| <b>3</b> | <b>Pin Configuration and Functions</b>                 | <b>5</b> | 4.29      | Wheel-Speed Output Switching Characteristics ....           | 16        |
| <b>4</b> | <b>Specifications</b>                                  | <b>8</b> | 4.30      | Typical Characteristics                                     | 18        |
| 4.1      | Absolute Maximum Ratings                               | 8        | <b>5</b>  | <b>Detailed Description</b>                                 | <b>19</b> |
| 4.2      | ESD Ratings  | 9        | 5.1       | Overview  | 19        |
| 4.3      | Recommended Operating Conditions                       | 9        | 5.2       | Functional Block Diagram                                    | 20        |
| 4.4      | Thermal Information                                    | 9        | 5.3       | Feature Description   | 20        |
| 4.5      | Input Port Electrical Characteristics                  | 10       | 5.4       | Device Functional Modes                                     | 39        |
| 4.6      | PWM Low-Side Driver Electrical Characteristics ...     | 10       | 5.5       | Programming   | 39        |
| 4.7      | Digital Low-Side Driver Electrical Characteristics ... | 10       | 5.6       | Register Maps   | 41        |
| 4.8      | High-Side Driver Electrical Characteristics            | 11       | <b>6</b>  | <b>Application and Implementation</b>                       | <b>47</b> |
| 4.9      | K-Line Electrical Characteristics                      | 11       | 6.1       | Application Information                                     | 47        |
| 4.10     | Warning Lamp Electrical Characteristics                | 11       | 6.2       | Typical Application   | 47        |
| 4.11     | Power Supply Electrical Characteristics                | 12       | <b>7</b>  | <b>Power Supply Recommendations</b>                         | <b>50</b> |
| 4.12     | SPI Electrical Characteristics                         | 12       | <b>8</b>  | <b>Layout</b>   | <b>50</b> |
| 4.13     | WL_LS Low-Side Switch Output Characteristics ...       | 12       | 8.1       | Layout Guidelines   | 50        |
| 4.14     | Wheel-Speed High-Side Driver Characteristics           | 12       | 8.2       | Layout Example  | 52        |
| 4.15     | Wheel-Speed Low-Side Driver Characteristics            | 13       | <b>9</b>  | <b>Device and Documentation Support</b>                     | <b>56</b> |
| 4.16     | Wheel-Speed Output Characteristics                     | 13       | 9.1       | Documentation Support                                       | 56        |
| 4.17     | RST Output Characteristics                             | 13       | 9.2       | Community Resources   | 56        |
| 4.18     | SPI Timing Electrical Characteristics                  | 13       | 9.3       | Trademarks  | 56        |
| 4.19     | Power Supply Switching Characteristics                 | 14       | 9.4       | Electrostatic Discharge Caution                             | 57        |
| 4.20     | Wheel-Speed Counter Switching Characteristics ...      | 14       | 9.5       | Glossary  | 57        |
| 4.21     | HS Driver Switching Characteristics                    | 14       | <b>10</b> | <b>Mechanical, Packaging, and Orderable Information</b>     | <b>57</b> |
| 4.22     | Digital Low-Side Driver Switching Characteristics ..   | 15       |           |   |           |

## 2 Revision History

| Changes from Original (August 2010) to Revision A | Page |
|---|------|
| • Released full version of the data sheet         | 1    |

### 3 Pin Configuration and Functions

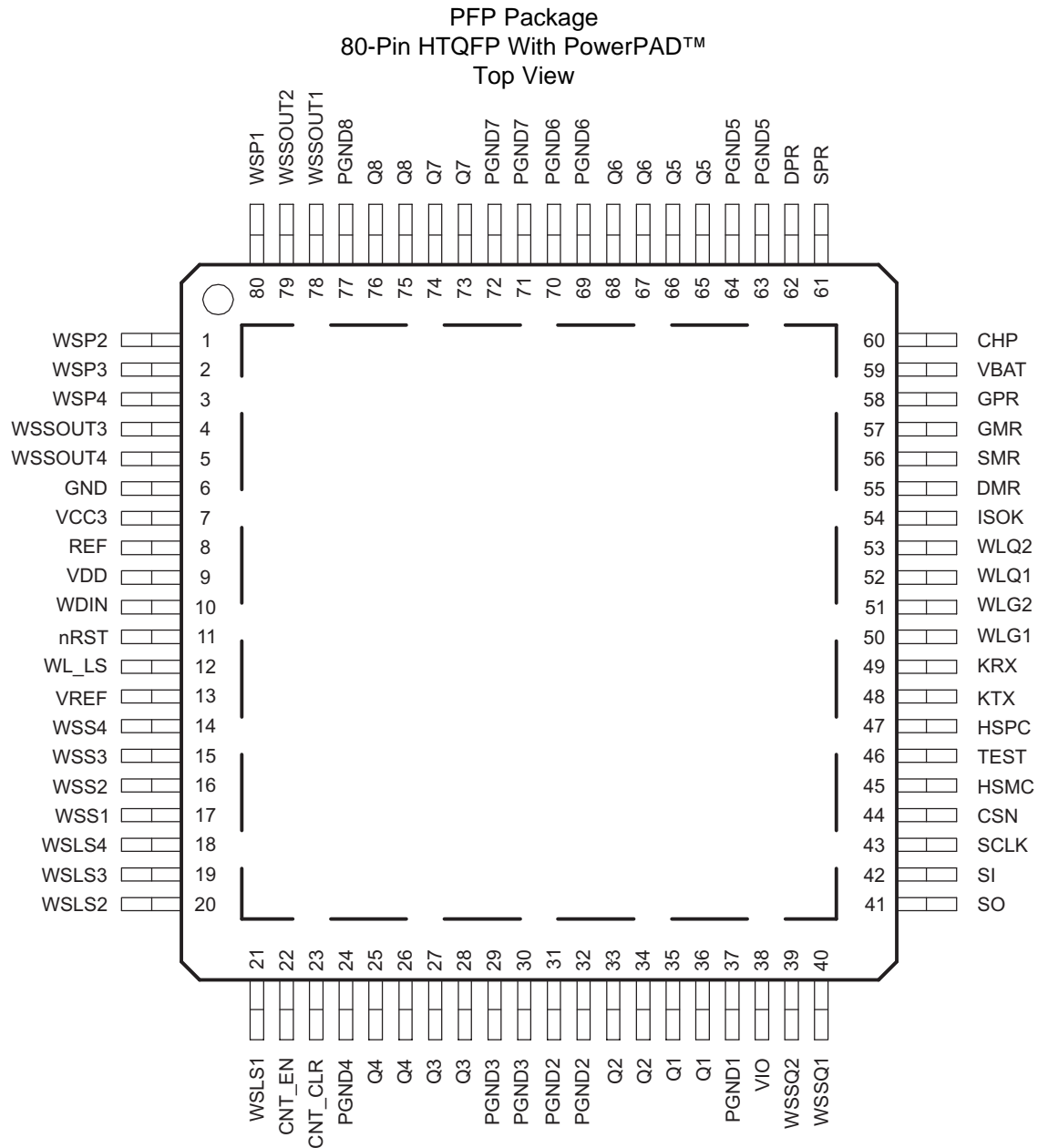

#### Pin Functions

| PIN     |     | I/O | FUNCTION DESCRIPTION  | INPUT PIN PULLUP OR PULLDOWN | PIN DURING RESET CONDITION   |
|---------|-----|-----|---|------------------------------|------------------------------|
| NAME    | NO. |     |   |                              |                              |
| CHP     | 60  | O   | External 100-nF capacitor to VBAT for an internal charge pump   | Pullup                       | VCHP = VBAT + 12 V (typical) |
| CNT_CLR | 23  | I   | Clear bit for the 8-bit digital counter that counts the wheel-speed sensor pulse edges seen in WSSOUTx  | Pulldown                     |                              |
| CNT_EN  | 22  | I   | Enable bit for the 8-bit digital counter that counts the wheel-speed sensor pulse edges seen in WSSOUTx | Pulldown                     |                              |
| CSN     | 44  | I   | SPI chip select active low pin  | Pullup                       |                              |

## Pin Functions (continued)

| PIN   |     | I/O    | FUNCTION DESCRIPTION  | INPUT PIN PULLUP OR PULLDOWN | PIN DURING RESET CONDITION         |
|-------|-----|--------|---|------------------------------|------------------------------------|
| NAME  | NO. |        |   |                              |                                    |
| DMR   | 55  | I      | Drain pin for master relay (MR) FET   | Pulldown                     | Externally supplied voltage (VBAT) |
| DPR   | 62  | I      | Drain pin for PR (pump motor relay) FET   | Pulldown                     | Externally supplied voltage (VBAT) |
| GMR   | 57  | O      | Gate pin for master relay (MR) FET  |                              | Low                                |
| GND   | 6   | Ground | Ground  |                              |                                    |
| GPR   | 58  | O      | Gate pin for PR (pump motor relay) FET  |                              | Low                                |
| HSMC  | 45  | I      | Logic input for MR (master relay) FET   | Pulldown                     |                                    |
| HSPC  | 47  | In     | Logic input for PR (pump motor relay) FET   | Pulldown                     |                                    |
| ISOK  | 54  | I/O    | K-line serial data transmit output to diagnosis tester and K-line serial data receive input from diagnosis tester | High-Z                       | High-Z                             |
| KRx   | 49  | O      | K-line serial data input to the microcontroller   |                              | High                               |
| KTx   | 48  | I      | K-line serial data output from the microcontroller  | Pullup                       |                                    |
| nRST  | 11  | I/O    | Reset signal that is used to either indicate an internal reset event or to induce an external reset               | Pulldown                     | See <a href="#">Table 5-1</a>      |
| PGND1 | 37  | Ground | Power ground pin for low-side valve driver 1  |                              |                                    |
| PGND2 | 31  | Ground | Power ground pin for low-side valve driver 2  |                              |                                    |
|       | 32  |        |   |                              |                                    |
| PGND3 | 29  | Ground | Power ground pin for low-side valve driver 3  |                              |                                    |
|       | 30  |        |   |                              |                                    |
| PGND4 | 24  | Ground | Power ground pin for low-side valve driver 4  |                              |                                    |
| PGND5 | 63  | Ground | Power ground pin for low-side valve driver 5  |                              |                                    |
|       | 64  |        |   |                              |                                    |
| PGND6 | 69  | Ground | Power ground pin for low-side valve driver 6  |                              |                                    |
|       | 70  |        |   |                              |                                    |
| PGND7 | 71  | Ground | Power ground pin for low-side valve driver 7  |                              |                                    |
|       | 72  |        |   |                              |                                    |
| PGND8 | 77  | Ground | Power ground pin for low-side valve driver 8  |                              |                                    |
| Q1    | 35  | O      | Drain pin of the low-side valve driver 1  |                              | High-Z                             |
|       | 36  |        |   |                              |                                    |
| Q2    | 33  | O      | Drain pin of the low-side valve driver 2  |                              | High-Z                             |
|       | 34  |        |   |                              |                                    |
| Q3    | 27  | O      | Drain pin of the low-side valve driver 3  |                              | High-Z                             |
|       | 28  |        |   |                              |                                    |
| Q4    | 25  | O      | Drain pin of the low-side valve driver 4  |                              | High-Z                             |
|       | 26  |        |   |                              |                                    |
| Q5    | 65  | O      | Drain pin of the low-side valve driver 5  |                              | High-Z                             |
|       | 66  |        |   |                              |                                    |
| Q6    | 67  | O      | Drain pin of the low-side valve driver 6  |                              | High-Z                             |
|       | 68  |        |   |                              |                                    |
| Q7    | 73  | O      | Drain pin of the low-side valve driver 7  |                              | High-Z                             |
|       | 74  |        |   |                              |                                    |
| Q8    | 75  | O      | Drain pin of the low-side valve driver 8  |                              | High-Z                             |
|       | 76  |        |   |                              |                                    |
| REF   | 8   | I      | Reference pin used to generate the internal bias currents. An external load of 10 k $\Omega$ is needed.           | Pulldown                     | REF = 1.25 V                       |
| SCLK  | 43  | I      | SPI clock pin   | Pulldown                     |                                    |

**Pin Functions (continued)**

| PIN     |     | I/O    | FUNCTION DESCRIPTION  | INPUT PIN PULLUP OR PULLDOWN | PIN DURING RESET CONDITION    |
|---------|-----|--------|---|------------------------------|-------------------------------|
| NAME    | NO. |        |   |                              |                               |
| SI      | 42  | I      | SPI input pin   | Pulldown                     |                               |
| SMR     | 56  | O      | Source pin for master relay (MR) FET  |                              | Low                           |
| SO      | 41  | O      | SPI output pin  |                              | High-Z                        |
| SPR     | 61  | I/O    | Source pin for PR (pump motor relay) FET  |                              | Low                           |
| TEST    | 46  | I      | Internal test pin. For any application, this is externally pulled to ground with a 1-kΩ resistor.                       | Pulldown                     |                               |
| VBAT    | 59  | Power  | Battery power supply (after reverse battery)  |                              |                               |
| VCC3    | 7   | Power  | Internal regulator for digital logic. Connect this pin only to a capacitor for regulator stability.                     |                              | VCC3 = 3.3 V                  |
| VDD     | 9   | Power  | 5-V external power supply   |                              |                               |
| VIO     | 38  | Power  | 3.3-V or 5-V external supply for the I/O buffers  |                              |                               |
| VREF    | 13  | I      | Externally supplied voltage reference used to set the current detection thresholds for the wheel-speed sensor interface | Pulldown                     |                               |
| WDIN    | 10  | I      | Watchdog timer signal   | Pulldown                     |                               |
| WLG1    | 50  | I      | Logic input for warning lamp driver 1   | Pulldown                     |                               |
| WLG2    | 51  | I      | Logic input for warning lamp driver 2   | Pulldown                     |                               |
| WLQ1    | 52  | O      | Drain pin of low-side warning lamp driver 1   |                              | See <a href="#">Table 5-1</a> |
| WLQ2    | 53  | O      | Drain pin of low-side warning lamp driver 2   |                              | See <a href="#">Table 5-1</a> |
| WL_LS   | 12  | O      | Low side switch for warning-lamp driver control that indicates the watchdog status                                      | High-Z                       | See <a href="#">Table 5-1</a> |
| WLS1    | 21  | I      | Wheel-speed sensor channel 1 low-side switch  | High-Z                       |                               |
| WLS2    | 20  | I      | Wheel-speed sensor channel 2 low-side switch  | High-Z                       |                               |
| WLS3    | 19  | I      | Wheel-speed sensor channel 3 low-side switch  | High-Z                       |                               |
| WLS4    | 18  | I      | Wheel-speed sensor channel 4 low-side switch  | High-Z                       |                               |
| WSP1    | 80  | O      | Supplies VBAT power to wheel-speed sensor channel 2   |                              | Low                           |
| WSP2    | 1   | O      | Supplies VBAT power to wheel-speed sensor channel 2   |                              | Low                           |
| WSP3    | 2   | O      | Supplies VBAT power to wheel-speed sensor channel 3   |                              | Low                           |
| WSP4    | 3   | O      | Supplies VBAT power to wheel-speed sensor channel 4   |                              | Low                           |
| WSS1    | 17  | I      | Wheel-speed sensor channel 1 signal pin   | Pulldown                     |                               |
| WSS2    | 16  | I      | Wheel-speed sensor channel 2 signal pin   | Pulldown                     |                               |
| WSS3    | 15  | I      | Wheel-speed sensor channel 3 signal pin   | Pulldown                     |                               |
| WSS4    | 14  | I      | Wheel-speed sensor channel 4 signal pin   | Pulldown                     |                               |
| WSSOUT1 | 78  | O      | Supplies processed wheel-speed pulse signal output to the microcontroller of channel 1 in a digital voltage form        |                              | Low                           |
| WSSOUT2 | 79  | O      | Supplies to the microcontroller the processed wheel-speed pulse signal of channel 2 in a digital voltage form           |                              | Low                           |
| WSSOUT3 | 4   | O      | Supplies to the microcontroller the processed wheel-speed pulse signal of channel 3 in a digital voltage form           |                              | Low                           |
| WSSOUT4 | 5   | O      | Supplies to the microcontroller the processed wheel-speed pulse signal of channel 4 in a digital voltage form           |                              | Low                           |
| WSSQ1   | 40  | O      | Drain pin for wheel-speed channel 1 output driver. Used to pass WSSOUT1 information to a high-voltage capable node      |                              | High-Z                        |
| WSSQ2   | 39  | O      | Drain pin for wheel-speed channel 2 output driver. Used to pass WSSOUT2 information to a high-voltage capable node      |                              | High-Z                        |
| PAD     |     | Ground | Thermal power ground pin for low-side drivers. Connect to PGNDx plane.  |                              |                               |

## 4 Specifications

### 4.1 Absolute Maximum Ratings

 over operating free-air temperature range (unless otherwise noted)<sup>(1)</sup>

|  |                     |  | MIN  | MAX                | UNIT |
|--|---------------------|--|------|--------------------|------|
| Supply voltage, $V_{CC}$   |                     | VDD, VIO   | -0.3 | 6.5                | V    |
| Input voltage, $V_{IN}$  |                     | WDIn, CNT_EN, CNT_CLR, SI, SCLK, CSN, KRX, KTX, WL_LS, WLGx, VIO, HSMC, HSPC | -0.3 | 6.5                | V    |
|  |                     | WSSQx, WSSx, WSLSx   | -0.3 | 40                 | V    |
|  |                     | CHP  | -0.3 | 55                 | V    |
|  |                     | DMR, DPR   | -1   | 40                 | V    |
|  |                     | SMR, SPR, TEST   | -0.3 | 40                 | V    |
| Supply voltage range, $V_{BAT}$  | Load dump           | VBAT   | -1   | 40                 | V    |
|  | Transient (2 ms)    |  | -1   | 40                 | V    |
| Load dump voltage, $V_{ISOK}^{(2)}$  |                     | ISOK   | -0.3 | 40                 | V    |
| Output voltage, $V_{OUT}$  |                     | Qx, WLQx, WSSQx  | -0.3 | 40                 | V    |
|  |                     | SO   | -0.3 | ( $V_{CC} + 0.3$ ) | V    |
|  |                     | nRST, WL_LS  | -0.3 | 6.5                | V    |
|  |                     | GMR, GPR   | -1   | 55                 | V    |
| REF voltage, $V_{REF}$   |                     | REF, VREF  | -0.3 | 6.5                | V    |
| Ground voltage, $V_{GND}$  |                     | PGNDx, GND   | -0.3 | 0.3                | V    |
| Drain current, $I_{IN}$  | Continuous          | Q1, 2, 3, 4  | 0    | 5                  | A    |
|  |                     | Q5, 6, 7, 8,   | 0    | 3.5                | A    |
|  |                     | WLQx   | 0    | 100                | mA   |
|  |                     | nRST   |      | ±20                | mA   |
|  | Negative Transients | Q1, 2, 3, 4 (10 ms)  | -5   | 0                  | A    |
|  |                     | Q5, 6, 7, 8, (10 ms)   | -5   | 0                  | A    |
|  |                     | WLQx (2 ms)  | -5   | 0                  | A    |
| Input current, $I_{IN}$  |                     | WDIN, WLGx, CNT_EN, CNT_CLR, SI, SCLK, CSN, KRX, KTX, HSMC, HSPC             |      | ±20                | mA   |
|  |                     | SPR, SMR   | -10  | 10                 |      |
| Output current, $I_{OUT}$  |                     | SO   |      | ±20                | mA   |
| REF current, $I_{REF}$   |                     | REF  |      | ±20                | mA   |
| Short-circuit current limit, $I_{SC}$                                      |                     | ISOK   |      | 1000               | mA   |
| Current with 510-Ω sense, $I_{ISOK}$                                       |                     | ISOK   | -100 | 113.5              | mA   |
| Supply current, $I_{CC}$   |                     | VDD  | -20  | 50                 | mA   |
|  |                     | VBAT (including WSSPx current limit thresholds)                              | -20  | 620                | mA   |
| Repetitive avalanche energy, $E_{AR\_DQ150}$ ( $T_J = 150^\circ\text{C}$ ) |                     | Q1, 2, 3, 4  |      | 50                 | mJ   |
| Repetitive avalanche energy, $E_{AR\_PQ150}$ ( $T_J = 150^\circ\text{C}$ ) |                     | Q5, 6, 7, 8  |      | 30                 | mJ   |
| ISOK clamp energy, $E_{Clamp}$   |                     | ISOK   |      | 20                 | mJ   |
| Operating virtual-junction temperature, $T_J$                              |                     |  | -40  | 175                | °C   |
| $T_{stg}$  |                     | Storage temperature range  | -65  | 150                | °C   |

(1) Stresses beyond those listed under *Absolute Maximum Ratings* may cause permanent damage to the device. These are stress ratings only, which do not imply functional operation of the device at these or any other conditions beyond those indicated under *Recommended Operating Conditions*. Exposure to absolute-maximum-rated conditions for extended periods may affect device reliability.

(2) This module survives double-battery jump-start conditions in typical application for 10 minutes duration.

## 4.2 ESD Ratings

|             |  |  | VALUES   | UNIT  |   |
|-------------|--|--|--|-------|---|
| $V_{(ESD)}$ | Electrostatic discharge                      | Human body model (HBM), per AEC Q100-002 <sup>(1)</sup>      | WLQx, Qx, VBAT, ISOK, DMR, SMR, WSSx, WLSx, WSPx, WSSQx, DPR, SPR (to GND) | ±4000 | V |
|             |  |  | Other pins   | ±2000 |   |
|             | Charged device model (CDM), per AEC Q100-011 | Corner pins (WSP2, WSP1, SPR, CHP SO, WSSQ1, WLS1, and WLS2) | ±750   |       |   |
|             |  | Other pins   | ±500   |       |   |

(1) AEC Q100-002 indicates HBM stressing is done in accordance with the ANSI/ESDA/JEDEC JS-001 specification.

## 4.3 Recommended Operating Conditions

over operating free-air temperature range (unless otherwise noted)

|                |                               |   | MIN | MAX            | UNIT |
|----------------|-------------------------------|---|-----|----------------|------|
| $V_{BAT}$      | Supply voltage, battery       | VBAT  | 6   | 20             | V    |
| $V_{DD}$       | Supply voltage                | VDD   | 4.5 | 5.5            | V    |
| $V_{IO\_3.3V}$ | Supply voltage I/O 3.3V       | VIO is a 3.3-V externally supplied power                          | 2.8 | 3.6            | V    |
| $V_{IO\_5V}$   | Supply voltage I/O 5V         | VIO is a 5-V externally supplied power                            | 4.5 | 5.5            | V    |
| $V_{IN}$       | Input voltage                 | WDIN, CNT_EN, CNT_CLR, SI, SCLK, CSN, nRST, HSMC, HSPC, KTX, WLGx | 0   | $V_{IO} + 0.5$ | V    |
| $V_{OUT}$      | Output voltage                | Qx, WLQx  | 0   | $V_{BAT}$      | V    |
| $T_A$          | Operating ambient temperature |   | –40 | 125            | °C   |

## 4.4 Thermal Information

| THERMAL METRIC <sup>(1)</sup> |  | TPIC7218-Q1 | UNIT |
|-------------------------------|--|-------------|------|
|                               |  | PFP (HTQFP) |      |
|                               |  | 80 PINS     |      |
| $R_{\theta JA}$               | Junction-to-ambient thermal resistance       | 27.2        | °C/W |
| $R_{\theta JC(top)}$          | Junction-to-case (top) thermal resistance    | 8.9         | °C/W |
| $R_{\theta JB}$               | Junction-to-board thermal resistance         | 11.1        | °C/W |
| $\Psi_{JT}$                   | Junction-to-top characterization parameter   | 0.3         | °C/W |
| $\Psi_{JB}$                   | Junction-to-board characterization parameter | 11          | °C/W |
| $R_{\theta JC(bot)}$          | Junction-to-case (bottom) thermal resistance | 0.3         | °C/W |

(1) For more information about traditional and new thermal metrics, see the *Semiconductor and IC Package Thermal Metrics* application report, [SPRA953](#).

## 4.5 Input Port Electrical Characteristics

 $V_{BAT} = 6\text{ V to }20\text{ V}$ ,  $V_{DD} = 4.5\text{ V to }5.5\text{ V}$ , over operating free-air temperature range (unless otherwise noted)

| PARAMETER       |   | MIN | TYP | MAX | UNIT          |
|-----------------|---|-----|-----|-----|---------------|
| $V_{IH\_3.3V}$  | Input high voltage (3.3-V compatible)                                       |     |     | 2.2 | V             |
| $V_{IL\_3.3V}$  | Input low voltage (3.3-V compatible)  | 0.8 |     |     | V             |
| $V_{hys\_3.3V}$ | Input voltage threshold hysteresis (5-V compatible)                         | 300 |     |     | mV            |
| $V_{IH\_5V}$    | Input high voltage (5-V compatible)   |     |     | 3.5 | V             |
| $V_{IL\_5V}$    | Input low voltage (5-V compatible)  | 1   |     |     | V             |
| $V_{hys\_5V}$   | Input voltage threshold hysteresis (5-V compatible)                         | 300 |     |     | mV            |
| $I_{PD}$        | Pin pulldown current, with $V_{IN} = V_{DD}$ (max)(5.5 V) to $V_{IL}$ (min) | 5   |     | 20  | $\mu\text{A}$ |
| $I_{pu\_csn}$   | CSN pullup current  | -20 |     | -5  | $\mu\text{A}$ |
| $I_{PD\_SMR}$   | SMR pin input current   | -1  | 0   | 1   | mA            |

## 4.6 PWM Low-Side Driver Electrical Characteristics

 $V_{BAT} = 6\text{ V to }20\text{ V}$ ,  $V_{DD} = 4.5\text{ V to }5.5\text{ V}$ , over operating free-air temperature range (unless otherwise noted)

| PARAMETER         | TEST CONDITIONS  | MIN  | TYP | MAX  | UNIT             |
|-------------------|--|------|-----|------|------------------|
| $R_{on\_PWMx}$    | On resistance<br>150°C junction temperature,<br>$6\text{ V} \leq V_{BAT} \leq 20\text{ V}$ |      |     | 0.3  | $\Omega$         |
| $I_{lim\_PWMx}$   | Current limit  | 5    |     |      | A                |
|                   | $T_A = -40^\circ\text{C}$  | 5.5  |     |      | A                |
| $I_{sink\_PWMx}$  | Sink current<br>Qx between 1 V and 20 V  | 10   |     | 60   | $\mu\text{A}$    |
| $I_{leak\_PWMx}$  | Drain leakage current<br>$V_{BAT} = 0$ , $V_{DD} = 0$                                      |      |     | 1    | $\mu\text{A}$    |
| $T_{sd\_PWMx}$    | Thermal shutdown junction temperature  | 185  |     | 215  | $^\circ\text{C}$ |
| $V_{olvtDIPWMx}$  | Open load comparator threshold voltage   | 1.84 |     | 2.16 | V                |
| $V_{cl\_PWMx}$    | Active clamp voltage   | 40   |     | 50   | V                |
| $V_{bvdss\_PWMx}$ | Max BVDSS voltage without active clamp   | 50   |     |      | V                |
| $I_{neg\_PWMx}$   | Maximum negative current for 10 ms   | -5   |     |      | A                |

## 4.7 Digital Low-Side Driver Electrical Characteristics

 $V_{BAT} = 6\text{ V to }20\text{ V}$ ,  $V_{DD} = 4.5\text{ V to }5.5\text{ V}$ , over operating free-air temperature range (unless otherwise noted)

| PARAMETER         | TEST CONDITIONS  | MIN  | TYP | MAX  | UNIT             |
|-------------------|--|------|-----|------|------------------|
| $R_{on\_DLSx}$    | On resistance<br>150°C junction temperature,<br>$6\text{ V} \leq V_{BAT} \leq 20\text{ V}$ |      |     | 0.2  | $\Omega$         |
| $I_{lim\_DLSx}$   | Current limit  | 6    |     |      | A                |
| $I_{sink\_DLSx}$  | Sink current<br>Qx output between 1 V and 20 V   | 10   |     | 60   | $\mu\text{A}$    |
| $I_{leak\_DLSx}$  | Drain leakage current<br>$V_{BAT} = 0$ , $V_{DD} = 0$                                      |      |     | 1    | $\mu\text{A}$    |
| $T_{sd\_DLSx}$    | Thermal shutdown junction temperature  | 185  |     | 215  | $^\circ\text{C}$ |
| $V_{olvt\_DLSx}$  | Open load comparator threshold   | 1.84 |     | 2.16 | V                |
| $V_{cl\_DLSx}$    | Active clamp voltage   | 40   |     | 50   | V                |
| $V_{bvdss\_DLSx}$ | Max BVDSS voltage without active clamp   | 50   |     |      | V                |
| $I_{neg\_DLSx}$   | Maximum negative current for 10 ms   | -5   |     |      | A                |

#### 4.8 High-Side Driver Electrical Characteristics

 $V_{BAT} = 6\text{ V to }20\text{ V}$ ,  $V_{DD} = 4.5\text{ V to }5.5\text{ V}$ , over operating free-air temperature range (unless otherwise noted)

| PARAMETER  | TEST CONDITIONS  | MIN            | TYP | MAX            | UNIT          |
|--|--|----------------|-----|----------------|---------------|
| $I_{DMR}/I_{DPR}$ Overcurrent threshold current                              |  | 60             | 75  | 90             | $\mu\text{A}$ |
| $V_{STG}$ On-state short-to-ground detection voltage                         |  | 1.6            | 2   | 2.4            | V             |
| $I_{LCdet}$ Leakage current in SMR pin                                       |  | 3              | 5   | 7              | mA            |
| $I_{leak\_SMR}$ Leakage current on SMR                                       | $0 \leq \text{SMR} \leq 20\text{ V}$ ,<br>$6\text{ V} \leq V_{BAT} \leq 20\text{ V}$ |                |     | 135            | $\mu\text{A}$ |
| $I_{Dark\_DMR}$ Dark current   | $0 \leq \text{DMR} \leq 20\text{ V}$ ,<br>$V_{BAT} = 0$ , $V_{DD} \leq 0$            |                |     | 2.5            | $\mu\text{A}$ |
| $V_{FGMR}/V_{FGPR}$ Voltage threshold FGMR in GMR pin and FGPR in GPR pin    |  | 1.6            | 2   | 2.4            | V             |
| $V_{gs\_clamp}$ Voltage clamp between GMR-SMR and GPR-SPR pins               |  | 16             |     | 20             | V             |
| $V_{ON}$ Output on voltage for GMR and GMR (each are turned on individually) | $6\text{ V} < V_{BAT} < 7\text{ V}$  | $V_{BAT} + 5$  |     | $V_{BAT} + 15$ | V             |
|  | $7\text{ V} \leq V_{BAT} < 10\text{ V}$  | $V_{BAT} + 7$  |     | $V_{BAT} + 15$ |               |
|  | $10\text{ V} \leq V_{BAT} < 20\text{ V}$   | $V_{BAT} + 10$ |     | $V_{BAT} + 15$ |               |
|  | $7\text{ V} \leq V_{BAT} < 10\text{ V}$  | $V_{BAT} + 7$  |     | $V_{BAT} + 15$ |               |
|  | $10\text{ V} \leq V_{BAT} < 20\text{ V}$   | $V_{BAT} + 10$ |     | $V_{BAT} + 15$ |               |

#### 4.9 K-Line Electrical Characteristics

 $V_{BAT} = 6\text{ V to }20\text{ V}$ ,  $V_{DD} = 4.5\text{ V to }5.5\text{ V}$ , over operating free-air temperature range (unless otherwise noted)

| PARAMETER                                       | TEST CONDITIONS  | MIN                   | TYP | MAX                   | UNIT          |
|---|--|-----------------------|-----|-----------------------|---------------|
| $V_{IL\_tx}$ KTX input low voltage threshold    |  | $0.3 \times V_{DD}$   |     |                       | V             |
| $V_{IH\_tx}$ KTX input high voltage threshold   |  |                       |     | $0.7 \times V_{DD}$   | V             |
| $I_{pu\_tx}$ KTX pullup current                 |  | -40                   |     | -2                    | $\mu\text{A}$ |
| $V_{OL\_rx}$ KRX output low voltage threshold   |  |                       |     | $0.2^* \times V_{DD}$ | V             |
| $V_{OH\_rx}$ KRX output high voltage threshold  |  | $0.8 \times V_{DD}$   |     |                       | V             |
| $T_{lim}$ Thermal shutdown temperature          |  | 185                   |     | 215                   | C             |
| $V_{hys\_kln}$ Thermal shutdown hysteresis      |  | 20                    |     | 30                    | C             |
| $V_{IL\_iso}$ ISOK input low voltage threshold  |  | $0.4 \times V_{BAT}$  |     |                       | V             |
| $V_{IH\_iso}$ ISOK input high voltage threshold |  |                       |     | $0.7 \times V_{BAT}$  | V             |
| $V_{hys\_iso}$ Input hysteresis                 | $V_{hys\_iso} = V_{IH\_iso} - V_{IL\_iso}$             | $0.05 \times V_{BAT}$ |     | $0.1 \times V_{BAT}$  | V             |
| $I_{SC\_iso}$ Short-circuit current limit       |  | 50                    |     | 1000                  | mA            |
| $V_{OL\_iso}$ Output low voltage                |  |                       |     | $0.1 \times V_{BAT}$  | V             |
| $V_{OH\_iso}$ Output high voltage               |  | $0.95 \times V_{BAT}$ |     |                       | V             |
| $I_{leak\_isok}$ Drain leakage current          | $V_{BAT} = 0$ , $V_{DD} = 0$ , $I_{SOK} = 12\text{ V}$ |                       |     | 6                     | $\mu\text{A}$ |

#### 4.10 Warning Lamp Electrical Characteristics

 $V_{BAT} = 6\text{ V to }20\text{ V}$ ,  $V_{DD} = 4.5\text{ V to }5.5\text{ V}$ , over operating free-air temperature range (unless otherwise noted)

| PARAMETER                                   | TEST CONDITIONS            | MIN | TYP | MAX | UNIT     |
|---|----------------------------|-----|-----|-----|----------|
| $R_{on\_WLQx}$ On resistance                | 150°C junction temperature |     |     | 4   | $\Omega$ |
| $I_{lim\_WLQx}$ Current limitation          |                            | 250 |     |     | mA       |
| $T_{sd\_WLQx}$ Thermal shutdown temperature |                            | 185 |     | 215 | C        |

## Warning Lamp Electrical Characteristics (continued)

 $V_{BAT} = 6\text{ V to }20\text{ V}$ ,  $V_{DD} = 4.5\text{ V to }5.5\text{ V}$ , over operating free-air temperature range (unless otherwise noted)

| PARAMETER         | TEST CONDITIONS                        | MIN                              | TYP | MAX | UNIT |    |               |
|-------------------|--|----------------------------------|-----|-----|------|----|---------------|
| $T_{hys\_WLQx}$   | Thermal shutdown hysteresis            |                                  |     | 20  | 30   | C  |               |
| $I_{sink\_WLQx}$  | Sink current                           | WLQx output between 1 V and 20 V |     |     | 10   | 60 | $\mu\text{A}$ |
| $I_{leak\_WLQx}$  | Drain leakage current                  | $V_{BAT} = 0$ , $V_{DD} = 0$     |     |     |      | 1  | $\mu\text{A}$ |
| $V_{olvt\_WLQx}$  | Open load comparator threshold voltage |                                  |     | 2.3 | 2.7  | V  |               |
| $V_{cl\_WLQx}$    | Active clamp voltage                   |                                  |     | 40  | 50   | V  |               |
| $V_{bvdss\_WLQx}$ | Max BVDSS voltage without active clamp |                                  |     | 50  |      | V  |               |
| $I_{neg\_WLQx}$   | Maximum negative current for 2 ms      |                                  |     | 5   |      | A  |               |

## 4.11 Power Supply Electrical Characteristics

 $V_{BAT} = 6\text{ V to }20\text{ V}$ ,  $V_{DD} = 4.5\text{ V to }5.5\text{ V}$ , over operating free-air temperature range (unless otherwise noted)

| PARAMETER           | TEST CONDITIONS  | MIN                                       | TYP   | MAX  | UNIT |  |
|---------------------|--|---|-------|------|------|--|
| $I_{VDD}$           | Current consumption on VDD                                 |   |       | 20   | mA   |  |
| $I_{VBAT}$          | Current consumption on VBAT                                |   |       | 10   | mA   |  |
| $V_{urvVDD}$        | Undervoltage shutdown voltage                              | 4.5                                       | 4.625 | 4.75 | V    |  |
| $V_{uvrhVDD}$       | Undervoltage reset threshold for microcontroller           | 4.6                                       | 4.725 | 4.85 | V    |  |
| $V_{VDD\_uvr\_hys}$ | Undervoltage recovery hysteresis                           | 50  |       |      | mV   |  |
| $V_{rstVDD}$        | Undervoltage reset voltage                                 |   |       | 3    | V    |  |
| $V_{uvVBAT}$        | Undervoltage shutdown                                      | 5.2                                       | 5.6   | 6    | V    |  |
| $V_{ovVBAT}$        | Overvoltage shutdown                                       | 27  | 29    | 31   | V    |  |
| $V_{REF}$           | Band-gap reference voltage                                 |   | 1.25  |      | V    |  |
|                     | External reference resistor accuracy (chip resistor)       | $R_{REF} = 10\text{ k}\Omega$             |       |      | 1%   |  |
|                     | External predriver capacitor tolerance                     | $C_{CHP} = 100\text{ nF}$                 |       |      | 20%  |  |
|                     | External load capacitor for internally used VCC3 regulator | $100\text{ pF} < C_{VCC3} < 10\text{ nF}$ |       |      | 20%  |  |

## 4.12 SPI Electrical Characteristics

over operating free-air temperature range (unless otherwise noted)

| PARAMETER | TEST CONDITIONS                  | MIN          | TYP | MAX | UNIT |
|-----------|----------------------------------|--------------|-----|-----|------|
| $V_{OH}$  | SO output threshold high voltage | $V_{DD} - 1$ |     |     | V    |
| $V_{OL}$  | SO output threshold low voltage  |              |     | 0.4 | V    |

## 4.13 WL\_LS Low-Side Switch Output Characteristics

 $V_{BAT} = 6\text{ V to }20\text{ V}$ ,  $V_{DD} = 4.5\text{ V to }5.5\text{ V}$ , over operating free-air temperature range (unless otherwise noted)

| PARAMETER | TEST CONDITIONS          | MIN                                      | TYP | MAX | UNIT |   |
|-----------|--------------------------|--|-----|-----|------|---|
| $V_{OL}$  | WL_LS output low voltage | $I_{OL} = 20\text{ mA}$ , $WDSTAT = '0'$ |     |     | 0.4  | V |

## 4.14 Wheel-Speed High-Side Driver Characteristics

 $V_{BAT} = 6\text{ V to }20\text{ V}$ ,  $V_{DD} = 4.5\text{ V to }5.5\text{ V}$ , over operating free-air temperature range (unless otherwise noted)

| PARAMETER          | TEST CONDITIONS                    | MIN   | TYP | MAX | UNIT |     |               |
|--------------------|------------------------------------|---|-----|-----|------|-----|---------------|
| $R_{on\_WSPx}$     | On resistance                      | 150°C junction temperature                                |     |     | 10   | 30  | $\Omega$      |
| $I_{leak\_WSPx}$   | Leakage current                    | Switch disabled, $V_{BAT} = 18\text{ V}$ ,                |     |     |      | 10  | $\mu\text{A}$ |
| $I_{rvleak\_WSPx}$ | Reverse polarity leakage current   | Switch disabled, $V_{BAT}$ open, $V_{WSPx} = 18\text{ V}$ |     |     |      | 100 | $\mu\text{A}$ |
| $I_{oc\_WSPx}$     | Short to ground current limitation |   |     | 50  | 150  | mA  |               |
| $V_{clamp\_WSPx}$  | Maximum output voltage             |   |     | 8   | 12   | 15  | V             |
| $C_{LOAD\_WSPx}$   | Maximum capacitive load            |   |     |     |      | 10  | nF            |

#### 4.15 Wheel-Speed Low-Side Driver Characteristics

 $V_{BAT} = 6\text{ V to }20\text{ V}$ ,  $V_{DD} = 4.85\text{ V to }5.5\text{ V}$ , over operating free-air temperature range (unless otherwise noted)

| PARAMETER         |   | TEST CONDITIONS   | MIN  | TYP                     | MAX | UNIT          |
|-------------------|---|---|------|-------------------------|-----|---------------|
| $R_{on\_WSSLx}$   | On resistance   | 150°C junction temperature  | 2    |                         | 10  | $\Omega$      |
| $I_{leak\_WSSLx}$ | Leakage current   | Switch disabled,<br>$V_{BAT} = 18\text{ V}$ , $V_{WSSLx} = 18\text{ V}$ |      |                         | 200 | $\mu\text{A}$ |
| $I_{leak\_WSSx}$  | Leakage current   | Switch disabled,<br>$V_{BAT} = 18\text{ V}$ , $V_{WSSLx} = 18\text{ V}$ |      |                         | 200 | $\mu\text{A}$ |
| $V_{REF}$         | Reference voltage used to set WSS threshold detection   |   | 1    |                         | 3.3 | V             |
| $V_{THRESH4}$     | 100% threshold detection $V_{REF} / R_{LOAD}$ (Intelligent Sensor)                            | $V_{WSSx} - V_{WSSLx}$  | -10% | $1 \times V_{REF}$      | 10% | V             |
| $V_{THRESH3}$     | 50% threshold detection $V_{REF} / R_{LOAD}$ (Intelligent Sensor)                             | $V_{WSSx} - V_{WSSLx}$  | -10% | $1 \times V_{REF}$      | 10% | V             |
|                   | 100% threshold detection $V_{REF} / R_{LOAD}$ (Active Sensor)                                 |   | -10% | $0.5 \times V_{REF}$    | 10% |               |
| $V_{THRESH2}$     | 25% threshold detection $V_{REF} / R_{LOAD}$ (Intelligent Sensor) $V_{WSSx} - V_{WSSLx}$      | $V_{WSSx} - V_{WSSLx}$  | -10% | $0.25 \times V_{REF}$   | 10% | V             |
|                   | 50% threshold detection $V_{REF} / R_{LOAD}$ (Active Sensor)                                  |   | -10% | $0.5 \times V_{REF}$    | 10% |               |
| $V_{THRESH1}$     | 11.25% threshold detection $V_{REF} / R_{LOAD}$ (Intelligent Sensor)                          | $V_{WSSx} - V_{WSSLx}$  | -20% | $0.1125 \times V_{REF}$ | 20% | V             |
|                   | 22.5% threshold detection $V_{REF} / R_{LOAD}$ (Active Sensor)                                |   | -20% | $0.225 \times V_{REF}$  | 20% |               |
| $V_{WSSthresh}$   | $V_{THRESH2} = V_{THRESH3} = V_{THRESH4} = 5\text{ kHz}$ ,<br>$V_{THRESH1} = \text{Measured}$ | 3 WSS channels switching at 5 kHz                                       |      |                         | 40  | dB            |

#### 4.16 Wheel-Speed Output Characteristics

 $V_{BAT} = 6\text{ V to }20\text{ V}$ ,  $V_{DD} = 4.5\text{ V to }5.5\text{ V}$ , over operating free-air temperature range (unless otherwise noted)

| PARAMETER         |  | TEST CONDITIONS             | MIN  | TYP | MAX  | UNIT          |
|-------------------|--|-----------------------------|------|-----|------|---------------|
| $R_{on\_WSSQx}$   | On resistance  | 150°C junction temperature  | 5    |     | 15   | $\Omega$      |
| $I_{lim\_WSSQx}$  | Current limitation                                     |                             | 50   |     |      | mA            |
| $I_{leak\_WSSQx}$ | Drain leakage current                                  | $V_{WSSQx} = 13.5\text{ V}$ |      |     | 20   | $\mu\text{A}$ |
| $V_{olvt\_WSSQx}$ | Open load/Short to ground comparator threshold voltage |                             | 1.84 | 2   | 2.16 | V             |
| $C_{load\_WSSQx}$ | Capacitive Load (Inductive load is not supported)      |                             |      |     | 22   | nF            |

#### 4.17 RST Output Characteristics

 $V_{BAT} = 6\text{ V to }20\text{ V}$ ,  $V_{DD} = 4.5\text{ V to }5.5\text{ V}$ , over operating free-air temperature range (unless otherwise noted)

| PARAMETER |                        | TEST CONDITIONS   | MIN | TYP | MAX | UNIT |
|-----------|------------------------|---|-----|-----|-----|------|
| $V_{OL}$  | RST output low voltage | $I_{OL} = 1.6\text{ mA}$  |     |     | 0.4 | V    |
|           |                        | $1\text{ V} < V_{DD} < V_{unVDD}$ , $I_{OL} = V_{DD}/10\text{ k}\Omega$ |     |     | 0.4 | V    |

#### 4.18 SPI Timing Electrical Characteristics

 $V_{BAT} = 6\text{ V to }20\text{ V}$ ,  $V_{DD} = 4.5\text{ V to }5.5\text{ V}$ , over operating free-air temperature range (unless otherwise noted) (see [Figure 4-1](#))

|                 |  | MIN  | NOM | MAX | UNIT |
|-----------------|--|------|-----|-----|------|
| $f_{SPI}$       | SPI operation frequency                                    | 4    |     | 8   | MHz  |
| $t_{SCLK}$      | SCLK clock period  | 125  |     |     | ns   |
| $T_{(WH)}$      | SCLK clock high time                                       | 62.5 |     |     | ns   |
| $T_{(WL)}$      | SCLK clock low time  | 62.5 |     |     | ns   |
| $t_{SU(lead)}$  | Setup time from falling edge of CSN to rising edge of SCLK | 62.5 |     |     | ns   |
| $t_{SU(lag)}$   | Setup time from falling edge of SCLK to rising edge of CSN | 62.5 |     |     | ns   |
| $t_{pd(SDOEN)}$ | Propagation delay from falling edge of CSN to SO valid     |      |     | 50  | ns   |

## SPI Timing Electrical Characteristics (continued)

$V_{BAT} = 6\text{ V to }20\text{ V}$ ,  $V_{DD} = 4.5\text{ V to }5.5\text{ V}$ , over operating free-air temperature range (unless otherwise noted) (see [Figure 4-1](#))

|                  |  | MIN                                  | NOM | MAX | UNIT |
|------------------|--|--------------------------------------|-----|-----|------|
| $t_{pd(SDODIS)}$ | Propagation delay from rising edge of CSN to SO Hi-Z state |                                      |     | 50  | ns   |
| $t_{pd(valid)}$  | Propagation delay from rising edge SCLK to SO              | 0.2 V1 < SO < 0.8 V1,<br>CL = 200 pF |     | 50  | ns   |

## 4.19 Power Supply Switching Characteristics

over operating free-air temperature range (unless otherwise noted)

| PARAMETER        | TEST CONDITIONS   | MIN | TYP  | MAX | UNIT          |
|------------------|---|-----|------|-----|---------------|
| $t_{RST}$        | Reset response time   |     |      | 5   | $\mu\text{s}$ |
| $t_{rst\_delay}$ | Delay time for reset from low to high (minimum reset hight) | 53  | 76.5 | 100 | ms            |
| $t_{VovVBAT}$    | Overvoltage blanking time                                   | 280 | 400  | 520 | $\mu\text{s}$ |
| $t_{VuvVBAT}$    | Undervoltage blanking time                                  | 280 | 400  | 520 | $\mu\text{s}$ |

## 4.20 Wheel-Speed Counter Switching Characteristics

$V_{BAT} = 6\text{ V to }20\text{ V}$ ,  $V_{DD} = 4.5\text{ V to }5.5\text{ V}$ , over operating free-air temperature range (unless otherwise noted)

| PARAMETER      | TEST CONDITIONS             | MIN | TYP | MAX | UNIT          |
|----------------|-----------------------------|-----|-----|-----|---------------|
| $t_{cnt\_clr}$ | CNT_CLR deglitcher duration | 4.2 |     | 7.8 | $\mu\text{s}$ |
| $t_{cnt\_en}$  | CNT_EN deglitcher duration  | 4.2 |     | 7.8 | $\mu\text{s}$ |

## 4.21 HS Driver Switching Characteristics

$V_{BAT} = 6\text{ V to }20\text{ V}$ ,  $V_{DD} = 4.5\text{ V to }5.5\text{ V}$ , over operating free-air temperature range (unless otherwise noted)

| PARAMETER             | TEST CONDITIONS                           | MIN   | TYP  | MAX  | UNIT          |               |
|-----------------------|---|---|--|------|---------------|---------------|
| $t_{Fovdet}$          | Overvoltage detection time                | 280   | 400  | 520  | $\mu\text{s}$ |               |
| $t_{GPRact}$          | Overvoltage activation time               | 320   | 460  | 600  | ms            |               |
| $t_{OCdet}$           | Overcurrent detection time                | 560   | 800  | 1040 | $\mu\text{s}$ |               |
| $t_{STG}$             | Short to ground detection time            | 70  | 100  | 130  | $\mu\text{s}$ |               |
| $t_{HSDUVBAT}$        | HSD deglitcher time for VBAT undervoltage | 1.3   |  | 2.5  | $\mu\text{s}$ |               |
| $t_{C1deg}$           | Comparator deglitcher time                |   |  | 4.2  | 7.8           | $\mu\text{s}$ |
| $t_{C2deg}$           |   |   |  |      |               |               |
| $t_{LCdet}$           | Leakage current detection time in SMR pin | 140   | 200  | 260  | $\mu\text{s}$ |               |
| $t_{Dark\_DMR}$       | Time to reach dark current                | After $V_{BAT} = 0\text{ V}$ and $V_{DD} = 0$ |  | 300  | $\mu\text{s}$ |               |
| $t_{STGMR}/t_{STGPR}$ | Turnon masking time <sup>(1)</sup>        |   |  | 5    | 8             | ms            |
| $t_{ON1}$             | Turnon time                               | GMR = 8 nF                                    | -6 V < $V_{BAT}$ < 7 V, GPR > $V_{BAT} + 4$        |      | 0.8           | ms            |
|                       |   |   | -7 V $\leq$ $V_{BAT}$ < 10 V, GPR > $V_{BAT} + 6$  |      | 1.3           |               |
|                       |   |   | -10 V $\leq$ $V_{BAT}$ < 20 V, GPR > $V_{BAT} + 9$ |      | 1.5           |               |
| $t_{ON2\_P}$          | Turnon time                               | GPR = 16 nF, GMR, GPR turn ON together        | -6 V < $V_{BAT}$ < 7 V, GPR > $V_{BAT} + 4$        |      | 2             | ms            |
|                       |   |   | -7 V $\leq$ $V_{BAT}$ < 10 V, GPR > $V_{BAT} + 6$  |      | 2.8           |               |
|                       |   |   | -10 V $\leq$ $V_{BAT}$ < 20 V, GPR > $V_{BAT} + 9$ |      | 3.3           |               |
| $t_{ON2\_S}$          | Turnon time                               | GPR = 16 nF, GPR turnon only                  | -6 V < $V_{BAT}$ < 7 V, GPR > $V_{BAT} + 4$        |      | 1.1           | ms            |
|                       |   |   | -7 V $\leq$ $V_{BAT}$ < 10 V, GPR > $V_{BAT} + 6$  |      | 1.5           |               |
|                       |   |   | -10 V $\leq$ $V_{BAT}$ < 20 V, GPR > $V_{BAT} + 9$ |      | 1.8           |               |

(1) This deglitcher applies only during the turnon time of GMR/GPR pins. During this masking time, no overcurrent conditions are reported.

## 4.22 Digital Low-Side Driver Switching Characteristics

 $V_{BAT} = 6\text{ V to }20\text{ V}$ ,  $V_{DD} = 4.5\text{ V to }5.5\text{ V}$ , over operating free-air temperature range (unless otherwise noted)

| PARAMETER              |   | TEST CONDITIONS  | MIN | TYP | MAX | UNIT          |
|------------------------|---|--|-----|-----|-----|---------------|
| $t_{soff\_DLSx}$       | Open load comparator deglitcher                         |  | 140 | 200 | 260 | $\mu\text{s}$ |
| $t_r/t_f\_DLSx$        | Rise time/fall time                                     | From 10% to 90%  | 10  |     | 50  | $\mu\text{s}$ |
| $t_{d\_on\_DLSx}$      | Turnon/turnoff delay time                               | From CSN going high to digital LSD turning off or turning on |     |     | 70  | $\mu\text{s}$ |
| $t_{d\_off\_DLSx}$     |   |  |     |     |     |               |
| $t_{off\_blank\_DLSx}$ | Blank time before output shutdown in current limitation |  | 140 | 200 | 260 | $\mu\text{s}$ |
| $t_{off\_tmp\_DLSx}$   | Blank time before output shutdown in overtemperature    |  | 140 | 200 | 260 | $\mu\text{s}$ |

## 4.23 PWM Low-Side Driver Switching Characteristics

 $V_{BAT} = 6\text{ V to }20\text{ V}$ ,  $V_{DD} = 4.5\text{ V to }5.5\text{ V}$ , over operating free-air temperature range (unless otherwise noted)

| PARAMETER              |   | TEST CONDITIONS                            | MIN | TYP | MAX  | UNIT          |
|------------------------|---|--|-----|-----|------|---------------|
| $t_{soff\_PWMx}$       | Open load comparator deglitcher time                            |  | 140 | 200 | 260  | $\mu\text{s}$ |
| $t_r/t_f\_PWMx$        | Rise time/fall time   | From 10% to 90%                            | 30  |     | 500  | ns            |
| $t_{d\_on\_PWMx}$      | Turnon delay time   | From CSN going high to PWM LSD turning off |     |     | 10   | $\mu\text{s}$ |
| $t_{d\_off\_PWMx}$     | Turnoff delay time  | From CSN going high to PWM LSD turning off |     |     | 2.25 | $\mu\text{s}$ |
| $t_{off\_blank\_PWMx}$ | Blank time before output shutdown in case of current limitation |  | 5   | 6   | 7    | $\mu\text{s}$ |
| $t_{off\_tmp\_PWMx}$   | Blank time before output shutdown during overtemperature        |  | 140 | 200 | 260  | $\mu\text{s}$ |

## 4.24 K-Line Switching Characteristics

 $V_{BAT} = 6\text{ V to }20\text{ V}$ ,  $V_{DD} = 4.5\text{ V to }5.5\text{ V}$ , over operating free-air temperature range (unless otherwise noted)

| PARAMETER                    |   | TEST CONDITIONS   | MIN | TYP | MAX | UNIT          |
|------------------------------|---|---|-----|-----|-----|---------------|
| $f_{t\_rx\_ft\_tx\_ft\_iso}$ | Transmission frequency                                | KRX, KTX, ISOK,<br>$R_{ISO} = 510\ \Omega$ , $C_{ISO} = 1.3\text{ nF}$    | 50  |     | 100 | kHz           |
| $t_{fall\_tx\_iso}$          | Fall time (20% to 80% of ISOK)                        | $R_{ISO} = 510\ \Omega$ to $V_{BAT}$ ,<br>$C_{ISO} = 10\text{ nF}$ to GND |     |     | 2   | $\mu\text{s}$ |
| $t_{rise\_tx\_iso}$          | Rise time (80% to 20% of ISOK)                        | $R_{ISO} = 510\ \Omega$ to $V_{BAT}$ ,<br>$C_{ISO} = 10\text{ nF}$ to GND |     |     | 15  | $\mu\text{s}$ |
| $t_{pd\_tx\_iso}$            | ISOK propagation delay                                | High to low,<br>$R_{ISO} = 510\ \Omega$ , $C_{ISO} = 10\text{ nF}$        |     |     | 6   | $\mu\text{s}$ |
|                              |   | Low to high,<br>$R_{ISO} = 510\ \Omega$ , $C_{ISO} = 10\text{ nF}$        |     |     | 6   |               |
| $t_{off\_iso\_rx}$           | Turnoff propagation delay time                        | $R_{ISO} = 510\ \Omega$ , $C_{ISO} = 10\text{ nF}$                        |     |     | 17  | $\mu\text{s}$ |
| $t_{off\_tx\_iso}$           |   |   |     |     |     |               |
| $t_{on\_iso\_rx}$            | Turnon propagation delay time                         | $R_{ISO} = 510\ \Omega$ , $C_{ISO} = 10\text{ nF}$                        |     |     | 4   | $\mu\text{s}$ |
| $t_{on\_tx\_iso}$            |   |   |     |     |     |               |
| $t_{off\_kln}$               | Blank time for overtemperature <sup>(1)</sup>         |   | 140 | 200 | 260 | $\mu\text{s}$ |
| $t_{on\_kln}$                |   |   |     |     |     |               |
| $t_{off\_isok}$              | Cumulative blank time before shutdown for overcurrent |   | 15  | 20  | 25  | $\mu\text{s}$ |

(1)  $t_{off\_kln}$  is the deglitcher time for K-Line to turnoff, and  $t_{on\_kln}$  is the deglitcher time for K-Line to turn on from shutdown.

## 4.25 Warning Lamp Switching Characteristics

 $V_{BAT} = 6\text{ V to }20\text{ V}$ ,  $V_{DD} = 4.5\text{ V to }5.5\text{ V}$ , over operating free-air temperature range (unless otherwise noted)

| PARAMETER        |                                      | TEST CONDITIONS | MIN | TYP | MAX | UNIT          |
|------------------|--------------------------------------|-----------------|-----|-----|-----|---------------|
| $t_{soff\_WLQx}$ | Open-load comparator deglitcher time |                 | 140 | 200 | 260 | $\mu\text{s}$ |

## Warning Lamp Switching Characteristics (continued)

 $V_{BAT} = 6\text{ V to }20\text{ V}$ ,  $V_{DD} = 4.5\text{ V to }5.5\text{ V}$ , over operating free-air temperature range (unless otherwise noted)

| PARAMETER              |   | TEST CONDITIONS | MIN | TYP | MAX | UNIT          |
|------------------------|---|-----------------|-----|-----|-----|---------------|
| $t_{r\_WLQx}$          | Rise time/fall time                               | From 10% to 90% |     |     | 60  | $\mu\text{s}$ |
| $t_{f\_WLQx}$          |   |                 |     |     |     |               |
| $t_{d\_on\_WLQx}$      | Turnon/turnoff delay time                         |                 |     |     | 25  | $\mu\text{s}$ |
| $t_{d\_off\_WLQx}$     |   |                 |     |     |     |               |
| $t_{off\_blank\_WLQx}$ | Blank time for overcurrent /short battery sensing |                 | 8   | 10  | 12  | $\mu\text{s}$ |
| $t_{off\_tmp\_WLQx}$   |   |                 |     |     |     |               |
| $t_{on\_tmp\_WLQx}$    | Blank time in case of overtemperature             |                 | 140 | 200 | 260 | $\mu\text{s}$ |

## 4.26 Watchdog Switching Characteristics

 $V_{BAT} = 6\text{ V to }20\text{ V}$ ,  $V_{DD} = 4.5\text{ V to }5.5\text{ V}$ , over operating free-air temperature range (unless otherwise noted)

| PARAMETER       |                              | TEST CONDITIONS                              | MIN  | TYP          | MAX | UNIT |
|-----------------|------------------------------|--|------|--------------|-----|------|
| $T_{WD}$        | Watchdog window              | Upper window (WDH<1:0>)                      | -10% | programmable | 10% | ms   |
|                 |                              | Lower window (WDL<1:0>)                      | 10%  | programmable | 10% |      |
|                 |                              | Out-of-range window (2 x WDH<1:0>)           | 10%  | programmable | 10% |      |
| $T_{WD\_PULSE}$ | Watchdog induced reset pulse | Watchdog out-of-range (counter stays at 000) | 1    | 1.5          | 2   | ms   |

## 4.27 Wheel Speed Interface Switching Characteristics

over operating free-air temperature range (unless otherwise noted)

| PARAMETER         |   | TEST CONDITIONS                       | MIN | TYP | MAX | UNIT          |
|-------------------|---|---------------------------------------|-----|-----|-----|---------------|
| $t_{rise\_WSPx}$  | Propagation delay from rising edge of CSN to the rising and falling edge of WSPx. | 20 mA load, $C_{load} = 10\text{ nF}$ |     |     | 100 | $\mu\text{s}$ |
| $t_{fall\_WSP}$   |   |                                       |     |     |     |               |
| $t_{rise\_WLSx}$  | Propagation delay from rising edge of CSN to rising and falling edge of WLSx      | 50-mA load                            |     |     | 50  | $\mu\text{s}$ |
| $t_{fall\_WLSx}$  |   |                                       |     |     |     |               |
| $t_{rise\_WSSQx}$ | Propagation delay from rising edge of CSN to rising and falling edge of WSSQx     | 50 mA load, $C = 200\text{ pF}$       |     |     | 50  | $\mu\text{s}$ |
| $t_{fall\_WSSQx}$ |   |                                       |     |     |     |               |

## 4.28 Wheel-Speed High-Side Driver Switching Characteristics

over operating free-air temperature range (unless otherwise noted)

| PARAMETER         |                                | TEST CONDITIONS | MIN | TYP | MAX | UNIT          |
|-------------------|--------------------------------|-----------------|-----|-----|-----|---------------|
| $t_{delay\_WSPx}$ | Delay time for fault reporting |                 | 80  | 100 | 120 | $\mu\text{s}$ |

## 4.29 Wheel-Speed Output Switching Characteristics

over operating free-air temperature range (unless otherwise noted)

| PARAMETER          |  | TEST CONDITIONS | MIN | TYP | MAX | UNIT          |
|--------------------|--|-----------------|-----|-----|-----|---------------|
| $T_{delay\_WSSQx}$ | Delay time for overcurrent fault reporting |                 | 15  | 20  | 25  | $\mu\text{s}$ |
|                    | Delay time for open load fault reporting   |                 | 140 | 200 | 260 | $\mu\text{s}$ |

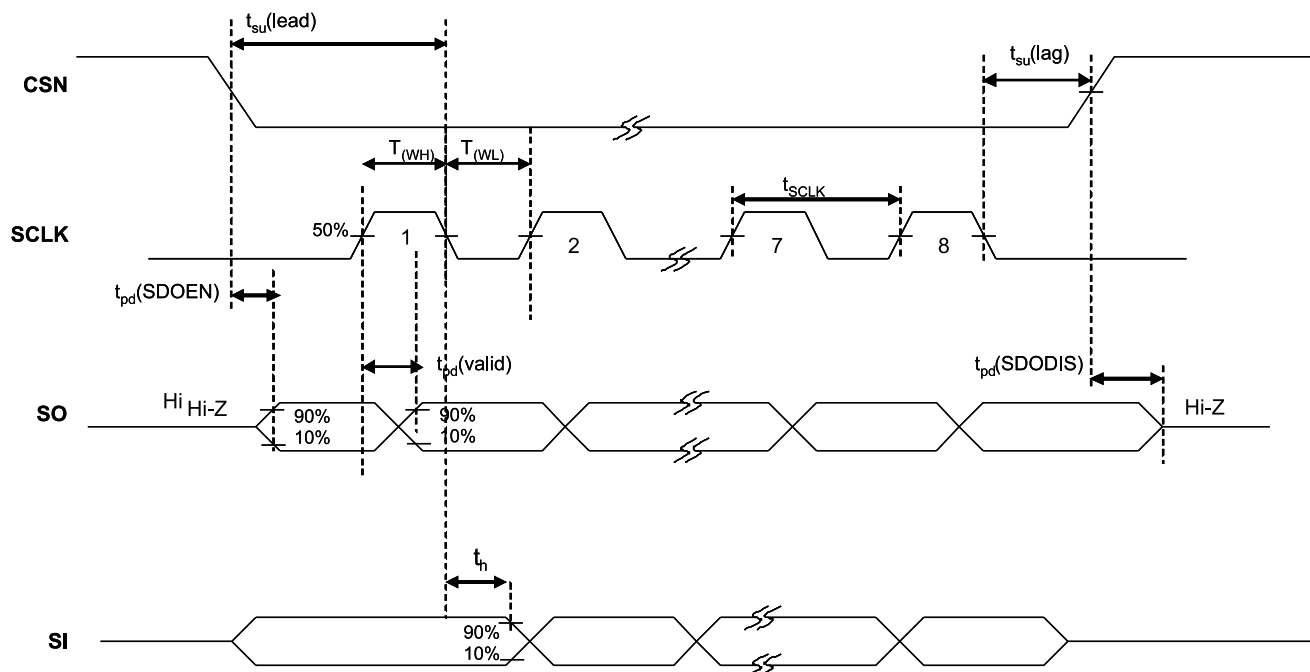

Figure 4-1. SPI Interface Input Timing

### 4.30 Typical Characteristics

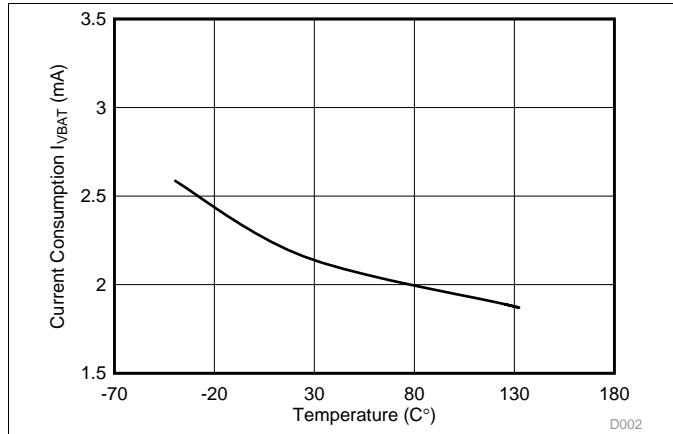

Figure 4-2. Current Consumption from VBAT vs Temperature

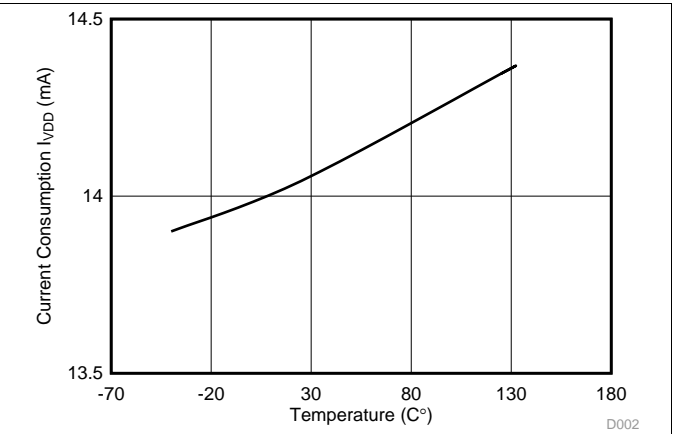

Figure 4-3. Current Consumption from VDD vs Temperature

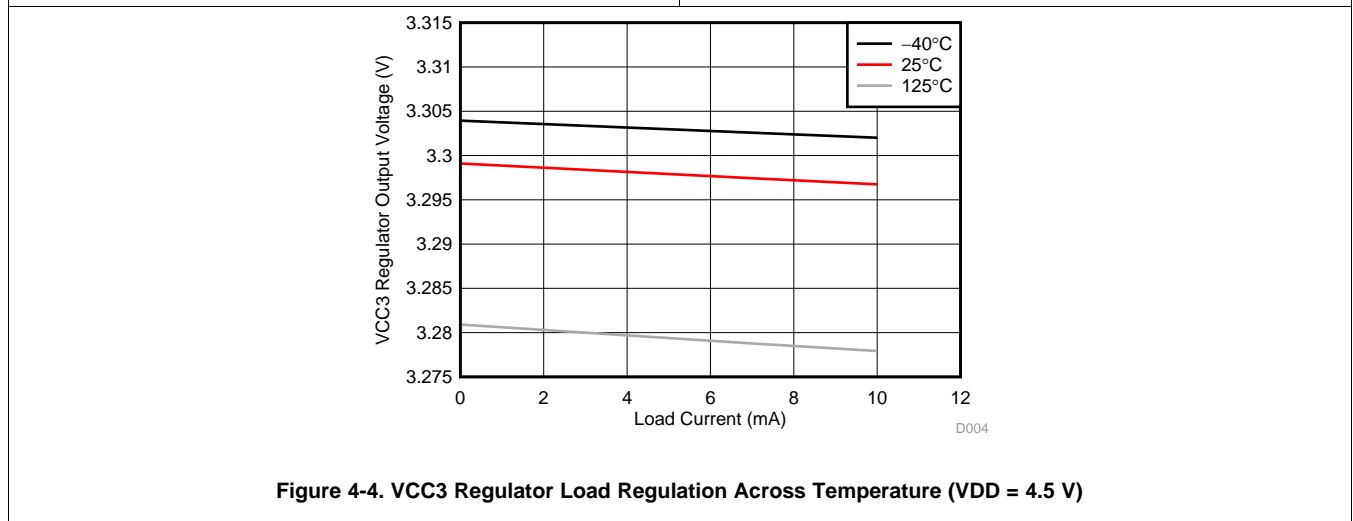

Figure 4-4. VCC3 Regulator Load Regulation Across Temperature (VDD = 4.5 V)

## 5 Detailed Description

### 5.1 Overview

The TPIC7218-Q1 device is an anti-lock braking controller capable of directly driving eight solenoid valves with internal high-current low-side drivers. Low-side drivers configured for digital control do not require external voltage clamps. The TPIC7218-Q1 device has gate drive capability for two high-side N-Channel MOSFETs that can be used to drive a pump motor and power to all solenoids. The TPIC7218-Q1 device provides a fault-tolerant interface for both Intelligent and Active wheel-speed sensors to an external microprocessor.

The TPIC7218-Q1 device can be used with either 3.3- or 5-V microprocessors and uses a standard SPI (Serial-Peripheral Interface). The TPIC7218-Q1 device has two internal open-drain warning lamp drivers that can be pulled up to battery voltage, as well as one low-voltage driver. An internal state machine monitors a watchdog input and reports faults on a warning-lamp pin and SPI register. A K-Line transceiver is also included. A multitude of safety and fault monitoring functionality supervise both system and TPIC7218-Q1 circuits. Faults must be polled and reset over SPI.

The TPIC7218-Q1 device is designed for use in harsh automotive environments, capable of withstanding high operating temperatures and electrically noisy signals and power. Short-to-ground, short-to-battery, and open-load conditions are tolerated and monitored. The TPIC7218-Q1 device also exhibits outstanding electromagnetic compatibility (EMC) performance.

## 5.2 Functional Block Diagram

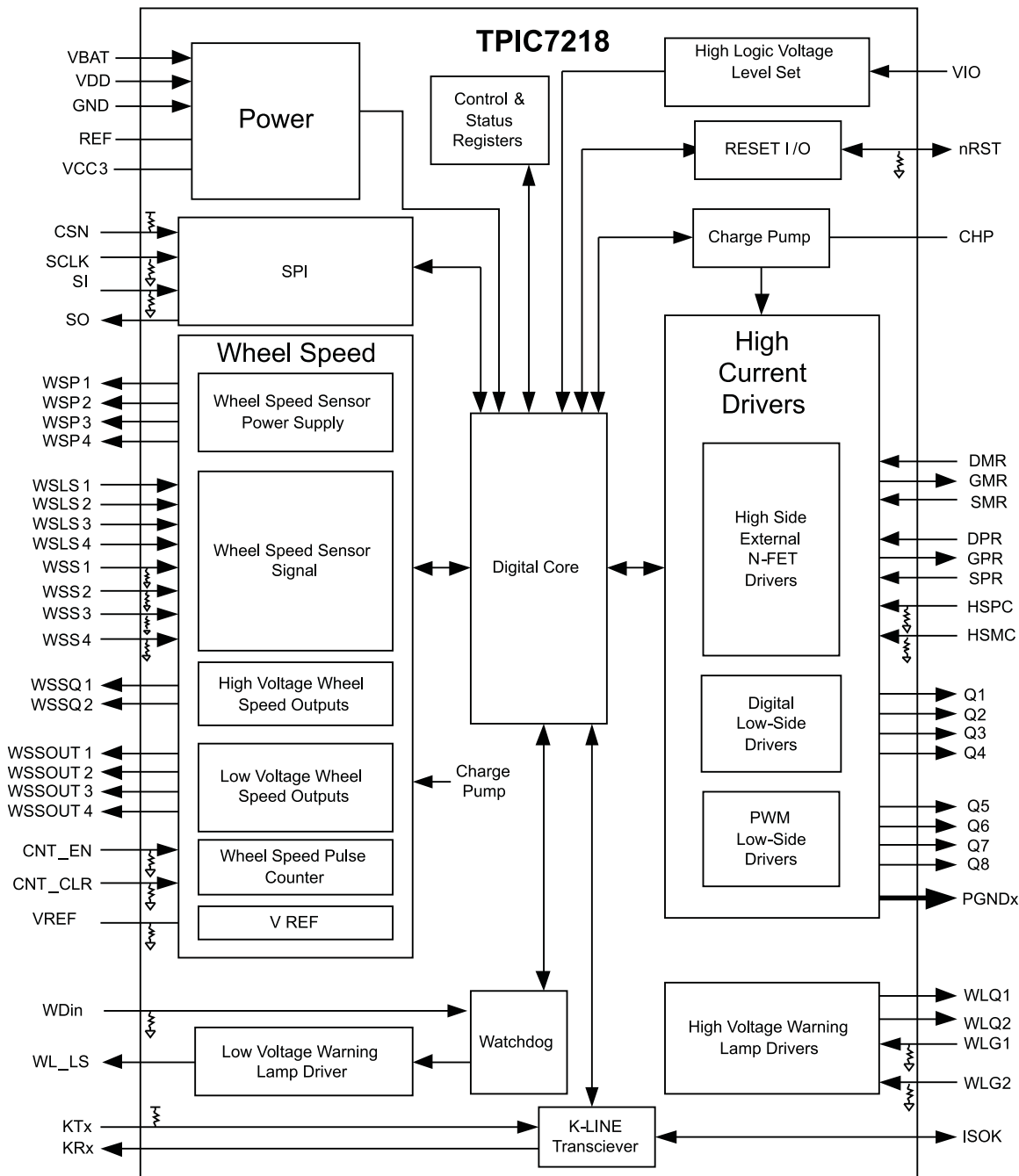

## 5.3 Feature Description

### 5.3.1 Ground Connections

The TPIC7218-Q1 device has two types of grounds: Power-grounds (PGND), which are used to provide a path for internal high-current open-drain FETs, and ground (GND), which are used to provide ground to all analog and digital circuitry. All the PGND pins and the thermal pad are internally shorted together. A very-low impedance connection exists internal to the TPIC7218-Q1 device between all power grounds and the ground pin (pin 6). TI recommends that all PGND, GND, and PowerPad pins be connected together at the pins of the TPIC7218-Q1 device to a solid ground plane. Failure to implement the grounding in this way is likely to result in poor EMC performance.

### 5.3.2 Charge Pump

An internal charge pump generates the charge necessary for proper operation of all drivers. A capacitor with a value of 100 nF connected between the CHP pin and VBAT pin is required for proper operation. The voltage on the CHP pin is typically 12 V greater than the voltage on the VBAT pin. When selecting a charge pump capacitor, care must be taken to ensure that the capacitors specifications are not violated.

### 5.3.3 Reference Current Generator

The TPIC7218-Q1 device generates an internal reference current that is output on the REF pin. This pin requires a 10-kΩ, ±1% resistor connected to GND.

### 5.3.4 Wheel-Speed Reference, $V_{REF}$

The voltage set on the  $V_{REF}$  pin must be stable at all times. If this voltage deviates from the desired setting, then all the wheel-speed thresholds will change. TI recommends externally monitoring the  $V_{REF}$  voltage to ensure proper operation of the wheel-speed functional block.

### 5.3.5 Faults Common To Most Functional Blocks

**Table 5-1. Summary Fault State Table**

| EVENT   | GMR                         | GPR          | WLQ1                  | WLQ2         | WL_LS              | nRST         | Q1-Q4  | Q5-Q8  | WSPx         | WSLx         | SPI                |
|---|-----------------------------|--------------|-----------------------|--------------|--------------------|--------------|--------|--------|--------------|--------------|--------------------|
| VDD undervoltage shutdown                               | OFF                         | OFF          | High Z                | High Z       | Low                | Low          | High Z | High Z | OFF          | High Z       | YES <sup>(1)</sup> |
| VDD undervoltage reset                                  | OFF                         | OFF          | High Z                | High Z       | High Z             | High Z       | High Z | High Z | OFF          | High Z       | NO                 |
| Recovery after VDD undervoltage reset (VDD>4.85V)       | OFF                         | OFF          | High Z                | High Z       | Low                | High Z       | High Z | High Z | OFF          | High Z       | YES                |
| Recovery after VDD undervoltage reset (VDD<4.75V)       | OFF                         | OFF          | High Z                | High Z       | Low                | Low          | High Z | High Z | OFF          | High Z       | YES                |
| VBAT overvoltage  | Not affected <sup>(2)</sup> | ON           | Not affected          | Not affected | Not affected       | Not affected | High Z | High Z | OFF          | High Z       | YES                |
| VBAT undervoltage                                       | OFF                         | OFF          | Not affected          | Not affected | Not affected       | Not affected | High Z | High Z | Not affected | Not affected | YES                |
| Thermal fault (OTSD = '1')                              | Not affected                | Not affected | High Z <sup>(3)</sup> | High Z       | Not affected       | Not affected | High Z | High Z | Not affected | Not affected | YES                |
| Watchdog bad (WDSTAT = '0')                             | OFF                         | OFF          | High Z                | High Z       | Low                | High Z       | High Z | High Z | Not affected | Not affected | YES                |
| While in Reset because of Watchdog going to state '000' | OFF                         | OFF          | High Z                | High Z       | Low                | Low          | High Z | High Z | OFF          | High Z       | YES <sup>(4)</sup> |
| external reset by pulling nRST pin low                  | OFF                         | OFF          | High Z                | High Z       | Low <sup>(5)</sup> | Low          | High Z | High Z | OFF          | High Z       | YES <sup>(1)</sup> |

- (1) The SPI is available if the ASIC is tested standalone. In a system level it would not be available because the VDD supplied microcontroller would be in reset condition.
- (2) This state depends on the setting of register map bit, OV\_GMR.
- (3) There are 8 thermal sensors in the ASIC. 3 implemented for the PWM drivers, 3 for the digital drivers one for the warning lamps and 1 for K-LINE. Only the drivers affected will turn off. There is no master thermal shutdown implemented for the ASIC.
- (4) While the watchdog is in reset, the only SPI settings that are not reset are the ones pertaining to the watchdog such as WD\_EN and WDH, WDL bits.
- (5) WL\_LS pin will be pulled low every time that WDSTAT = 0. This can result because of a bad watchdog event or because WD\_EN = 0. WL\_LS pin will be High Z when WDSTAT = 1.

### 5.3.6 PWM Low-Side Drivers

The TPIC7218-Q1 device features eight low-side drivers, four of which can be used for pulse width modulation (PWM) of solenoids. The low-side driver pins: Q5, Q6, Q7, and Q8 are open-drain MOSFETs that are capable of sinking large amounts of current. Each driver is monitored for three fault conditions: overcurrent, open-load, and over-temperature. In addition, driver operation is dependent on other fault conditions: VBAT undervoltage, VBAT overvoltage, VDD undervoltage, watchdog fault. See the application circuit and register diagram in [Figure 5-1](#).

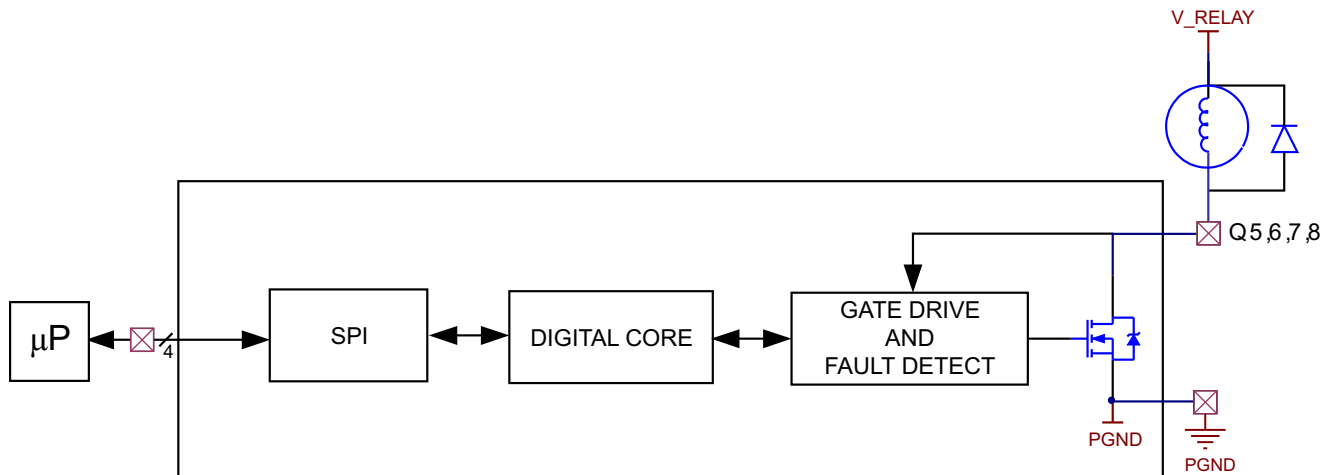

Figure 5-1. PWM Driver Register and Application Circuit Diagram

Each PWM driver features a 10-bit configurable duty-cycle setting, and options for independent phase control. Available phases of 0°, 90°, 180°, and 270° can be set for each driver in registers 0x14, 0x16, 0x18, and 0x1A. Changes in the dedicated 2-bits result in a phase change in the following complete period to prevent glitches. Table 5-2 lists the available phase options based on the settings of the dedicated 2-bit selection

Table 5-2. PWM Phase Selection

| PWMQX <sub>Phase&lt;1&gt;</sub> | PWMQX <sub>Phase&lt;0&gt;</sub> | SELECTED PHASE |
|---------------------------------|---------------------------------|----------------|
| 0                               | 0                               | 0°             |
| 1                               | 0                               | 90°            |
| 0                               | 1                               | 180°           |
| 1                               | 1                               | 270°           |

Each duty cycle of the PWM driver can be selected by setting the appropriate bits using Equation 1.

$$DutyCycle = \frac{PWMQx_{<9:0>}}{1024} * 100\% \tag{1}$$

For example, a setting of 0x3FF causes a 100% duty cycle and a setting of 0x000 causes a 0% duty cycle.

All 10 bits must be written for the new duty cycle code to be latched into the state machine. Changes in the 10-bit result in a duty-cycle change in the following complete period to prevent glitches. PWM drivers can be used as digital drivers by fully turning them on (100% duty cycle) and off (0% duty cycle). However, care must be taken not to violate electrical specifications when using PWM drivers in this way (such as energy handling capability).

The frequency is also configurable (see [Table 5-3](#)), but is not independent for each enabled driver; all PWM drivers are set by selecting a 2-bit value in register 0x12. Frequency selection changes take place only when the PWM drivers are disabled and then re-enabled.

**Table 5-3. PWM Frequency Selection**

| PWM <sub>Freq</sub> <1> | PWM <sub>Freq</sub> <0> | SELECTED FREQUENCY |
|-------------------------|-------------------------|--------------------|
| 0                       | 0                       | 2 kHz              |
| 1                       | 0                       | 4 kHz              |
| 0                       | 1                       | 8 kHz              |
| 1                       | 1                       | 16 kHz             |

For example, if Q5 is enabled while the frequency setting is <00> but Q6 is enabled after the frequency setting was changed to <11>, then Q5 is switching at 2 kHz and Q6 is switching at 16 kHz.

Each PWM driver monitors, reports, and has integrated protection for many electrical fault conditions. Overcurrent faults are reported as a 1 in register 0x02, (bits 0, 2, 4, and 6 are referenced by bits F5, F6, F7, and F8) and cause the affected driver to disable after a deglitch time of  $\text{toff\_blank\_PWMx}$ . Over-temperature (junction) faults are reported in register 0x03, (bit-6 OTSD) and cause not only the affected driver, but also the adjacent driver to disable after a deglitch time of  $\text{toff\_tmp\_PWMx}$ . The PWM drivers also check for an open-load or short to ground condition whenever they are not disabled. This type of fault is reported as 1 in register 0x02, (bits 1, 3, 5, 7 are referenced by bits S5, S6, S7, and S8). A master low-side fault bit in register 0x00, (bit-0) becomes high whenever any of the previously mentioned overcurrent or open-load faults occur. Fault flags can be cleared after the removal of the fault condition by reading the appropriate fault reporting register. When the fault flags are cleared, the low-side master fault bit (FAIL) can be cleared by reading it.

The PWM drivers also respond to fault conditions within other functional blocks. The drivers are disabled whenever VBAT undervoltage, VBAT overvoltage, or VDD undervoltage fault bits in register 0x00 are set. Also watchdog fault can cause PWM drivers to disable, if register 0x11, bit-4 (WD\_EN) is set. This bit defaults to 0 upon power up. Any of these faults do not cause the FAIL bit to be set.

Faults can be cleared by reading the appropriate fault reporting register. When the faults are cleared, the drivers can be re-enabled. To enable or re-enable a driver, simply toggle the driver bits (GE5, GE6, GE7, GE8) by writing a 0, then 1. Fault reporting bits do not have any affect on PWM drivers; only the actual fault condition causes a driver to disable. Nevertheless, TI recommends clearing the fault bits by reading these bits before enabling the drivers.

Besides monitoring and reporting faults, PWM drivers have overvoltage-protection circuitry built in. An active-clamp monitors the voltage on PWM driver pins and limits it to  $V_{\text{cl\_PWMx}}$ . At the system level, PWM drivers use an external recirculation diode in parallel with the inductive load.

### 5.3.7 Digital Low-Side Drivers

The TPIC7218-Q1 device features eight low-side drivers, four of which can be used digital control of solenoids. The low-side driver pins: Q1, Q2, Q3, and Q4 are open-drain MOSFETs that are capable of sinking large amounts of current. Each driver is monitored for three fault conditions: overcurrent, open-load, and over-temperature. However, driver operation also is dependant on other fault conditions: VBAT undervoltage, VBAT overvoltage, VDD undervoltage, watchdog fault. See the application circuit and register diagram in [Figure 5-2](#).

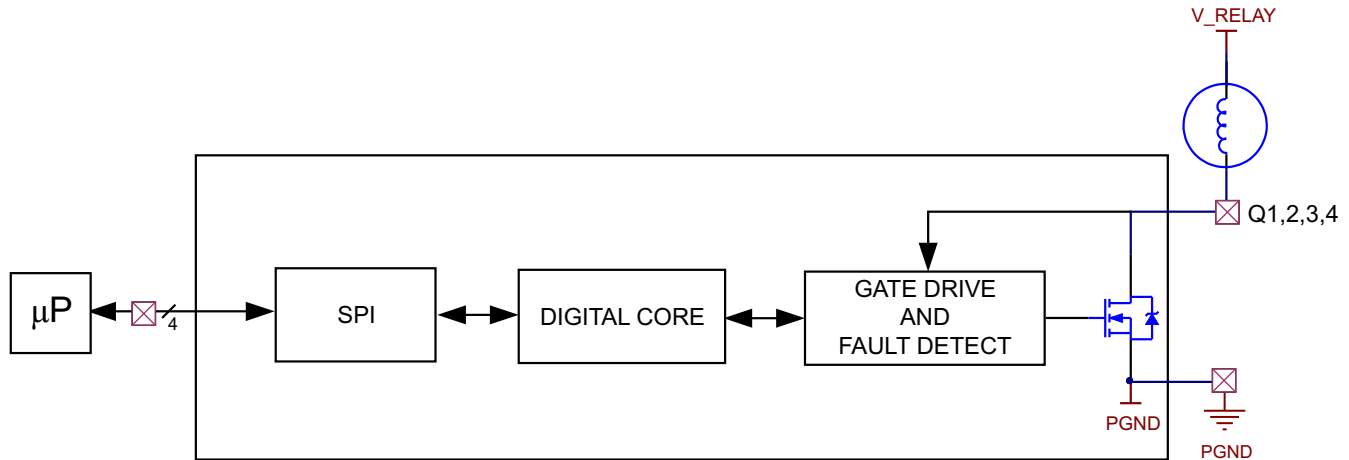

**Figure 5-2. Digital Driver Register and Application Circuit Diagram**

Each digital driver monitors, reports, and has integrated protection for many electrical fault conditions. Overcurrent faults are reported as a 1 in register 0x01, (bits 0, 2, 4, and 6 are referenced by bits F1, F2, F3, and F4) and cause the affected driver to disable after a deglitch time of  $\text{toff\_blank\_DLSx}$ . Over-temperature (junction) faults are reported in register 0x03, (bit-6 OTSD) and cause not only the affected driver, but also the adjacent driver to disable after a deglitch time of  $\text{toff\_tmp\_DLsLx}$ . Digital drivers also check for an open-load or short to ground condition whenever they are not enabled. This type of fault is reported as a 1 in register 0x01, (bits 1, 3, 5, 7 are referenced by S1, S2, S3, and S4). The master low-side fault bit in register 0x00, (bit-0) becomes high whenever an overcurrent or open-load fault occurs. Fault flags can be cleared after the removal of the fault condition by reading the appropriate fault reporting register. When this occurs the low-side master fault bit (FAIL) can be cleared by reading it.

The digital drivers also respond to fault conditions within other functional blocks. These drivers are disabled whenever the VBAT undervoltage, VBAT overvoltage, or VDD undervoltage fault bits in register 0x00 are set. Also, a watchdog fault can cause the digital drivers to disable if register 0x11, bit-4 (WD\_EN) is set. This bit defaults to 0 upon power up. Any of these faults do not cause the FAIL bit to be set.

Faults can be cleared by reading the appropriate fault reporting register. When this is complete the digital drivers can be re-enabled. To enable or re-enable a driver, simply toggle the driver bits (GE1, GE2, GE3, GE4) by writing a 0, then 1. Fault reporting bits do not have any affect on the digital drivers; only the actual fault condition will cause a driver to disable. Nevertheless, TI recommends clearing the fault bits by reading them before enabling the drivers.

Besides monitoring and reporting faults, digital drivers have overvoltage protection circuitry built in. An active-clamp monitors voltage on the pins of these drivers and limits the voltage to  $V_{\text{cl\_DLSx}}$ .

### 5.3.8 High-Side Drivers

The TPIC7218-Q1 device features two independent high-side gate drivers to control and monitor external N-Channel FETs. The pins, GPR, SPR, and DPR, are typically used to control an external N-MOSFET for the purpose of providing power to a motor pump. The pins, GMR, SMR, and DMR are typically used to control an external N-MOSFET for the purpose of providing power to the solenoid coils. When activated, the gate voltage drive on the GPR and GMR pins is sufficient to provide a strong  $V_{GS}$  because of a built-in charge pump. High-side drivers are electrically protected and monitored for fault conditions.

#### 5.3.8.1 High-Side Terminals: GPR, SPR, DPR, and HSPC

The GPR, SPR, and DPR (gate, source, and drain-pump relay) pins connect to an external N-MOSFET as shown in Figure 5-3. The purpose of this MOSFET is to relay the VBAT power to a pump motor. The N-MOSFET is turned on when the GPR pin is enabled. The GPR pin is controlled by either the HSPC pin or the GE\_PR bit, bit-3 of address 0x11 as listed in Table 5-4.

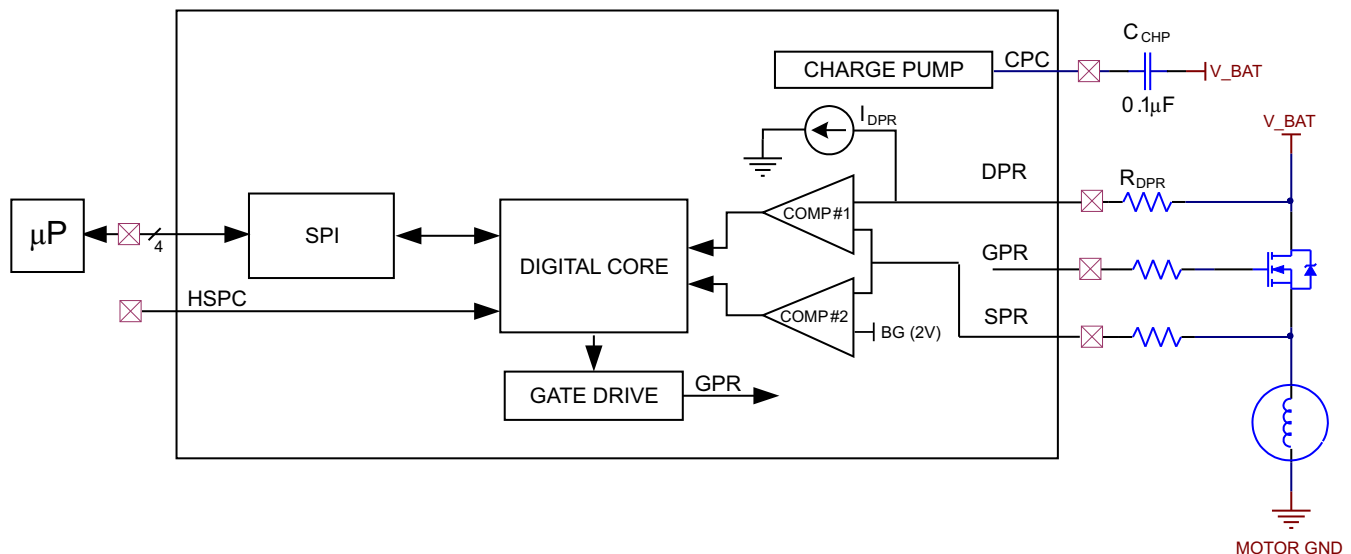

Figure 5-3. GPR, SPR, DPR, and HSPC Register and Application Circuit Diagram

Table 5-4. High-Side Operation Logic

| HSPC PIN | GE_PR BIT | GPR GATE PIN |
|----------|-----------|--------------|
| LOW      | 0         | OFF          |
| LOW      | 1         | ON           |
| HIGH     | 0         | ON           |
| HIGH     | 1         | ON           |
| OPEN     | 1         | ON           |
| OPEN     | 0         | OFF          |

The overcurrent detection of the external N-MOSFET is triggered by a voltage difference between the DPR and SPR pins in comparator COMP #1. To set the overcurrent threshold the external series resistor,  $R_{DPR}$ , must be sized to generate a particular input voltage (in conjunction with  $I_{DPR}$ ) on one input of the comparator. The other input voltage of the comparator changes as a function of the  $R_{DS_{ON(MAX)}}$  and  $I_{DS}$  values of the N-MOSFET. By comparing these voltages, the N-MOSFET overcurrent condition is reported. Given the  $R_{DS_{ON(MAX)}}$  value of the N-MOSFET and the desired overcurrent threshold,  $R_{DPR}$  can be calculated using Equation 2.

$$V_{BAT} - (I_{DS} * R_{DS_{ON(MAX)}}) > V_{BAT} - (I_{DPR} * R_{DPR}) \quad (2)$$

If the  $V_{DS}$  value of the N-MOSFET exceeds the threshold set by the comparator for more than the deglitcher time,  $t_{OCdet}$ , the GPR pin switches off and the appropriate fault flag (OCPR) is set high. When the overcurrent condition ends, the GPR pin can be switched on again with the SPI enable bit or the external enable pin.

Faults detected on VDD, VBAT, Watchdog (if WD\_EN bit is high) prevent the high-side driver from enabling; GPR remains low or turns off. At the time the high-side driver is enabled, voltage on GPR pin is tested for a short-to-ground condition only after a certain delay time defined as  $t_{STGPR}$ . If a short is detected the GPR pin remains low. Any time the high-side driver is enabled overcurrent in the external MOSFET, short-to-ground on GPR, and short-to-ground on SMR can cause a fault condition and disable the high-side driver.

An overvoltage condition (such as load-dump) on VBAT turns the GPR pin on (clamping any energy from the alternator). If VBAT returns to normal operating voltage from an overvoltage fault condition, the GPR pin remains on for a minimum time,  $t_{GPRact}$ .

If an overvoltage condition occurs on VBAT, the fault flag, FOV, is set after a deglitch time,  $t_{FOVdet}$ . With the overvoltage removed, the FOV flag can be cleared by reading address 0x00. After the fault bit is cleared, the GPR pin can be re-enabled. The GPR pin does not respond to successive overvoltage conditions until after a blanking time. See Table 5-5 and Figure 5-4 for more details.

**Table 5-5. Pump Relay Fault and Operation**

| SYSTEM EVENT  | FAULT BITS AFFECTED      | TPIC7218-Q1 STATE |             | NOTES   |
|---|--------------------------|-------------------|-------------|---|
|   |                          | BEFORE EVENT      | AFTER EVENT |   |
| VDD Undervoltage  | PORn = 1                 | GPR ON            | GPR OFF     | nRST is internally driven low                   |
| VBAT Overvoltage ( $>V_{ovVBAT}$ )                          | FOV = 1                  | GPR OFF           | GPR ON      |   |
| VBAT Undervoltage ( $<V_{uvVBAT}$ )                         | FUV = 1                  | GPR ON            | GPR OFF     |   |
| Watchdog fault ( must be enabled)                           | WDSTAT = 0, WD_FAULT = 1 | GPR ON            | GPR OFF     | WD_EN = 1 (enabled)                             |
| nRST pin externally driven low                              | Erst = 1                 | GPR ON            | GPR OFF     |   |
| Overcurrent in motor  | OCPR=1, FHSD = 1         | GPR ON            | GPR OFF     | OCPR <sub>DIS</sub> = 0 (disabled)              |
| Overcurrent in motor  | OCPR=1, FHSD = 1         | GPR ON            | GPR ON      | OCPR <sub>DIS</sub> = 1 (enabled)               |
| Short to GND on GPR, while GPR is OFF (time $> t_{STGPR}$ ) | FGPR = 1, FHSD = 1       | GPR OFF           | GPR OFF     | FGPR <sub>DIS</sub> = 0 (disabled), turn ON GPR |
| Short to GND on GPR, while GPR is ON                        | FGPR = 1, FHSD = 1       | GPR ON            | GPR OFF     | FGPR <sub>DIS</sub> = 0 (enabled)               |
| Short to GND on GPR, while GPR is OFF (time $> t_{STGPR}$ ) | FGPR = 1, FHSD = 1       | GPR OFF           | GPR ON      | FGPR <sub>DIS</sub> = 1 (enabled), turn ON GPR  |
| Short to GND on GPR, while GPR is ON                        | FGPR = 1, FHSD = 1       | GPR ON            | GPR ON      | FGPR <sub>DIS</sub> = 1 (enabled)               |
| Short to GND on SPR   | STGPR = 1, FHSD = 1      | GPR ON            | GPR ON      | STGPR <sub>DIS</sub> = 1 (enabled)              |
| Short to GND on SPR   | STGPR = 1, FHSD = 1      | GPR ON            | GPR OFF     | STGPR <sub>DIS</sub> = 0 (disabled)             |

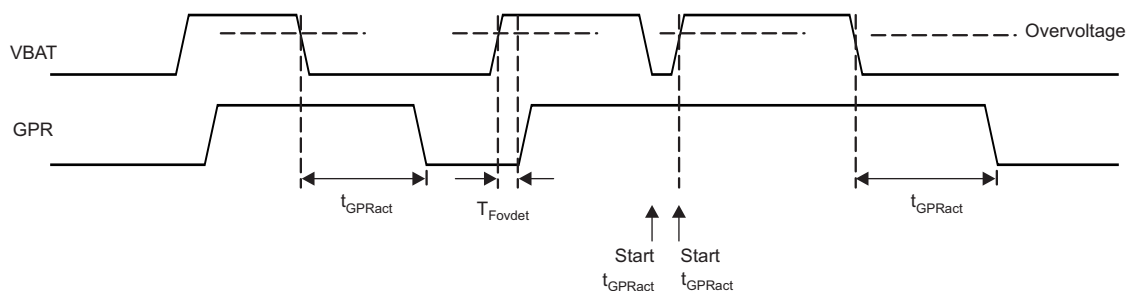

**Figure 5-4. Pump Relay High-Side Driver Overvoltage Behavior**

The pump relay external MOSFET is electrically protected from voltage spikes by an active voltage clamp that limits any voltage levels between the GPR and SPR pins that are larger than  $V_{gs\_clamp}$ .

The GPR function supports PWM output. The charge on the charge-pump capacitor,  $C_{CHP}$ , which is lost when GPR is switched on, is refreshed before the start of the next PWM cycle to a value that sufficiently ensures proper turnon behavior. The PWM capability consists of a period of  $T = 5$  ms with a duty cycle 10% to 90%. When selecting a duty cycle the rise and fall times of GPR must be taken into account.

### 5.3.8.2 High-Side Terminals: GMR, SMR, DMR, and HSMC

The GMR, SMR, and DMR (gate, source, and drain master relay) pins connect to an external N-MOSFET as shown in Figure 5-5. The purpose of this MOSFET is to relay VBAT power to a master power supply for solenoid coils. The N-MOSFET turns on when the GMR pin is enabled. The GMR pin function is controlled by either the HSMC pin or the GE\_MR bit, bit-2 of address 0x11 as shown in Table 5-6.

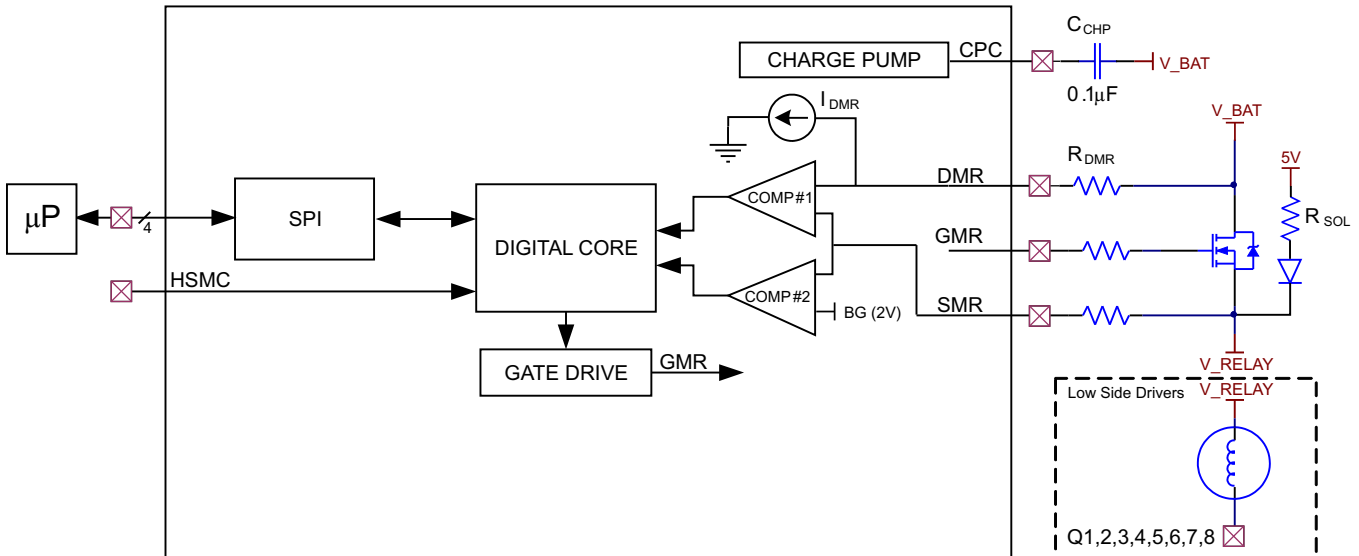

Figure 5-5. GMR, SMR, DMR, and HSMC Register and Application Circuit Diagram

Table 5-6. High-Side Operation Logic

| HSMC PIN | GE_MR BIT | GMR GATE PIN |
|----------|-----------|--------------|
| LOW      | 0         | OFF          |
| LOW      | 1         | ON           |
| HIGH     | 0         | ON           |
| HIGH     | 1         | ON           |
| OPEN     | 1         | ON           |
| OPEN     | 0         | OFF          |

The overcurrent detection of the external N-MOSFET is triggered by a voltage difference between the DMR and SMR pins in comparator COMP #1. To set the overcurrent threshold, the external series resistor,  $R_{DMR}$ , must be sized to generate a particular input voltage (in conjunction with  $I_{DMR}$ ) on one input of the comparator. The other input voltage of the comparator changes as a function of the  $R_{DS_{ON(MAX)}}$  and  $I_{DS}$  values of the N-MOSFET. By comparing these voltages, the N-MOSFET overcurrent condition is reported. Given the  $R_{DS_{ON(MAX)}}$  value of the N-MOSFET and the desired overcurrent threshold,  $R_{DMR}$  can be calculated using Equation 3.

$$VBAT - (I_{DS} * R_{DS_{ON(MAX)}}) > VBAT - (I_{DMR} * R_{DMR}) \quad (3)$$

If the  $V_{DS}$  of the N-MOSFET exceeds the threshold set by the comparator for more than the deglitcher time,  $t_{OCdet}$ , the GMR pin switches off and the appropriate fault flag (OCMR) is set high. When the overcurrent condition ends, the GMR pin can be switched on again with the SPI enable bit or the external enable pin.

Faults detected on VDD, VBAT, Watchdog (if WD\_EN bit is high) prevent the high-side driver from enabling; the GMR pin remains low or turns off. At the time the high-side driver is enabled, the voltage on the GMR pin is tested for a short-to-ground condition only after a certain delay time defined as  $t_{STGPR}$ . If a short is detected the GMR pin remains low. Any time the high-side driver is enabled overcurrent in MOSFET, short-to-ground on the GMR pin, and short-to-ground on the SMR pin can cause a fault condition and disable the high-side driver.

An overvoltage condition (such as a load-dump) on VBAT either turns the GMR pin off or allows it to remain in the previous state depending on the setting of bit 5 (OV\_GMR) in register 0x11. With the overvoltage removed, the fault flag FOV can be cleared by reading address 0x00.

The main relay external MOSFET is electrically protected from voltage spikes by an active voltage clamp that limits any voltage levels between GMR and SMR larger than  $V_{gs\_clamp}$ .

Load-leakage faults are tested by sourcing a current,  $I_{LCdet}$ , out of the SMR pin into the source of the external N-MOSFET. After a time,  $t_{LCdet}$ , the SMR voltage is checked to see if it is above VDD. If no leakage is present, the source is above VDD and the GMR pin is turned on. If leakage is present, the source is below VDD and the GMR pin does not turn on. A high on the LMR bit indicates a load-leakage fault. During a load-leakage fault, the SMR pin is biased to the voltage set by the external resistor ( $R_{SOL}$ ) and a series diode to VDD. Without this path, the SMR pin is floating and may not display faults properly.

Table 5-7 lists a summary of the faults that affect the GMR pin behavior.

**Table 5-7. Master Relay Fault and Operation**

| SYSTEM EVENT  | FAULT BITS AFFECTED         | TPIC7218-Q1 STATE |             | NOTES   |
|---|-----------------------------|-------------------|-------------|---|
|   |                             | BEFORE EVENT      | AFTER EVENT |   |
| VDD Undervoltage  | PORn = 1                    | GMR ON            | GMR OFF     | nRST pin is internally driven low               |
| VBAT Overvoltage ( $>V_{ovVBAT}$ )                          | FOV = 1                     | GMR ON            | GMR OFF     | OV_GMR = 1                                      |
| VBAT Overvoltage ( $>V_{ovVBAT}$ )                          | FOV = 1                     | GMR ON            | GMR ON      | OV_GMR = 0                                      |
| VBAT Undervoltage ( $<V_{uvVBAT}$ )                         | FUV = 1                     | GMR ON            | GMR OFF     |   |
| Watchdog fault ( must be enabled)                           | WDSTAT = 0,<br>WD_FAULT = 1 | GMR ON            | GMR OFF     | WD_EN = 1 (enabled)                             |
| nRST pin externally driven low                              | Erst = 1                    | GMR ON            | GMR OFF     |   |
| Overcurrent in master relay                                 | OCMR=1,FHSD = 1             | GMR ON            | GMR OFF     | OCMR <sub>DIS</sub> = 0 (disabled)              |
| Overcurrent in master relay                                 | OCMR=1,FHSD = 1             | GMR ON            | GMR ON      | OCMR <sub>DIS</sub> = 1 (enabled)               |
| Short to GND on GMR, while GMR is OFF (time > $t_{STGMR}$ ) | FGMR = 1,FHSD = 1           | GMR OFF           | GMR OFF     | FGMR <sub>DIS</sub> = 0 (disabled), turn ON GMR |
| Short to GND on GMR, while GMR is ON                        | FGMR = 1,FHSD = 1           | GMR ON            | GMR OFF     | FGMR <sub>DIS</sub> = 0 (disabled)              |
| Short to GND on GMR, while GMR is OFF (time > $t_{STGMR}$ ) | FGMR = 1,FHSD = 1           | GMR OFF           | GMR ON      | FGMR <sub>DIS</sub> = 1 (enabled), turn ON GMR  |
| Short to GND on GMR, while GMR is ON                        | FGMR = 1,FHSD = 1           | GMR ON            | GMR ON      | FGMR <sub>DIS</sub> = 1 (enabled)               |
| Short to GND on SMR   | STGMR = 1,FHSD = 1          | GMR ON            | GMR OFF     | STGMR <sub>DIS</sub> = 0 (disabled)             |
| Short to GND on SMR   | STGMR = 1,FHSD = 1          | GMR ON            | GMR ON      | STGMR <sub>DIS</sub> = 1 (enabled)              |
| GMR is turned on while Q1-Q8 on                             | LGMR = 1,FHSD = 1           | GMR OFF           | GMR OFF     | LGMR <sub>DIS</sub> = 0 (disabled), turn ON GMR |
| GMR is turned on while Q1-Q8 on                             | LGMR = 1,FHSD = 1           | GMR OFF           | GMR ON      | LGMR <sub>DIS</sub> = 1 (enabled), turn ON GMR  |

The high-side GMR, SMR, and DMR functionality also includes logic that facilitates system diagnostic testing. The operational status, as well as some fault conditions can be determined for both high-side drivers (HSD) and low-side drivers (LSD). [Table 5-8](#) lists the details.

**Table 5-8. High-Side Driver Logic (GMR Only)**

| HSD FET | LSD FETx | COMP #1 (HSDC1) | COMP #2 (HSDC2) | RESULT  |
|---------|----------|-----------------|-----------------|---|
| ON      | OFF      | L               | L               | Normal operating condition for HSD FET          |
| ON      | OFF      | H               | L               | HSD FET open                                    |
| ON      | ON       | L               | L               | Normal operating condition for HSD and LSD FETs |
| ON      | ON       | H               | L               | HSD (GMR) FET in overcurrent condition          |
| ON      | ON       | H               | H               | HSD (GMR) FET in short to ground condition      |
| OFF     | ON       | H               | H               | Normal operating condition for LSD              |
| OFF     | ON       | H               | L               | Open load or open LSD FETx                      |
| OFF     | OFF      | H               | L               | Normal operating condition for HSD FET          |
| OFF     | OFF      | H               | H               | Load short to ground/LSD FETx short to ground   |

### 5.3.9 Wheel-Speed Sensing

The TPIC7218-Q1 device is capable of interfacing with industry standard Active and Intelligent wheel-speed sensors. The TPIC7218-Q1 device features an analog front end that provides power, ground, and interprets current-encoded speed and diagnostic information (Intelligent VDA sensors only) for sensors. Current thresholds can be adjusted to easily interface with most sensors. By setting a voltage on the  $V_{REF}$  pin in conjunction with an appropriate current sense resistor,  $R_{LOAD}$ , current levels through the wheel-speed sensors are evaluated according to the threshold states. Active wheel-speed sensor current pulse levels can be: undercurrent, overcurrent, wheel-speed-pulse-low (for example 7 mA), and wheel-speed-pulse-high (for example 14 mA). Intelligent wheel-speed sensor current pulse levels can be: undercurrent, overcurrent, wheel-speed-pulse-low (for example 7 mA), wheel-speed-pulse-high (for example 28 mA), and diagnostic-data-bit (for example 14 mA). Wheel-speed-pulse-low and wheel-speed-pulse-high logic state is directly interpreted to a digital voltage output for each sensor (rotational speed). Diagnostic information, diagnostic-data-bit, is directly decoded and placed in four 9-bit registers. Rotational speed information (for two sensors) is also available on high-voltage open-drain outputs. Rotational wheel-speed pulse information for any of the sensors can be MUX-ed into a digital pulse counter. This counter increments on both rising and falling edges. The 8-bit counter, along with other wheel-speed bits are available over SPI. Wheel-speed pins are also electrically protected from typical fault conditions. See [Figure 5-6](#) for register and applications information.

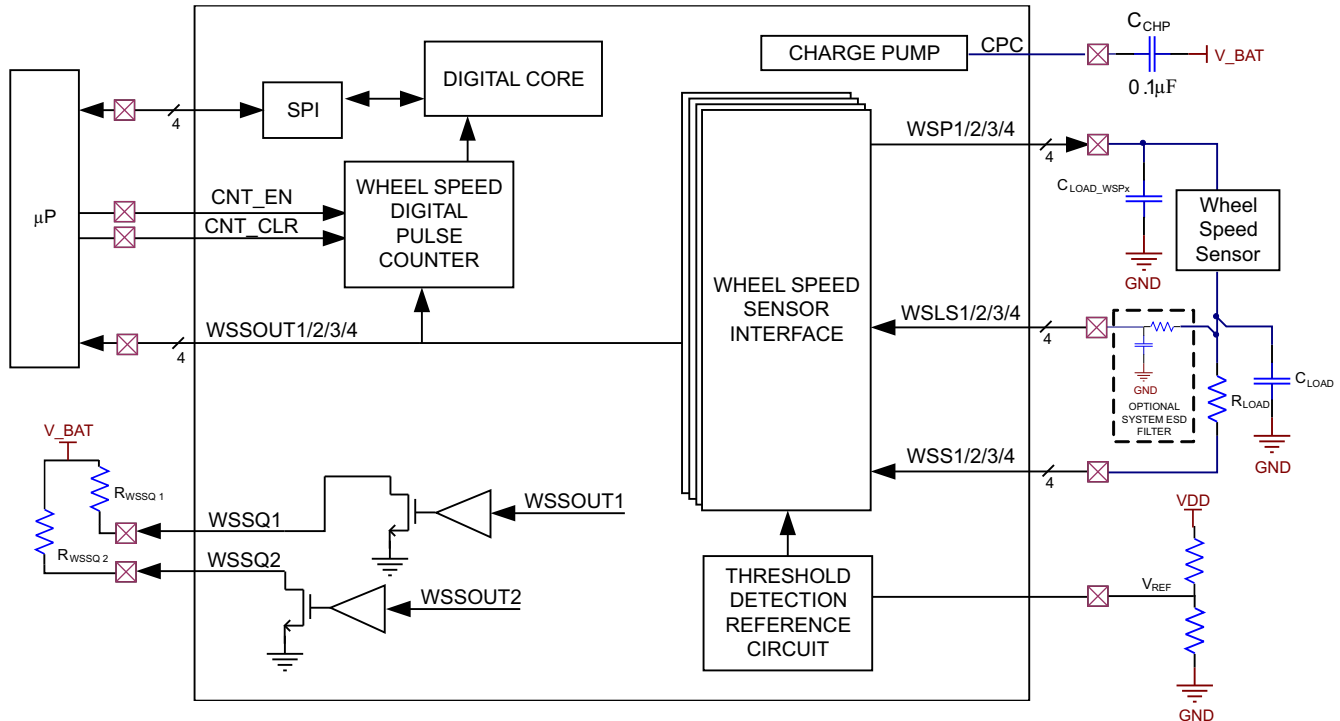

**Figure 5-6. Wheel-Speed Register and Application Circuit Diagram**

The TPIC7218-Q1 device has three pins for each of the four wheel-speed sensors. The WSPx pins provide a path for current from VBAT to the wheel-speed sensor. The WLSx pins provide a path for current from the wheel-speed sensor to GND. The WSSx pins monitor current through the sensor by measuring a voltage across the  $R_{LOAD}$  resistance, shown in Figure 5-6.

Current is provided to the sensor from the WSP1, WSP2, WSP3, and WSP4 pins. When enabled (by setting the WSPx bits in register 0x1B), the WSPx pins output current and are voltage clamped to  $V_{clamp\_WSPx}$ . WSPx pins are electrically protected from short-to-battery, short-to-ground, and overcurrent. Short-to-battery fault bits, WSPx\_STB, are located in registers 0x08, 0x0A, 0x0C, 0x0E and overcurrent fault bits, WSPxILIMIT, are located in register 0x1D. If a fault is detected, then the WSPx pins disable. Reading these registers clears the fault bits after the fault condition has been removed.

Current from the sensors is returned to the WSP1, WSP2, WSP3, and WSP4 pins of the TPIC7218-Q1 device, thus providing a path to ground. Current out of the sensor passes through a series resistor,  $R_{LOAD}$ , into internal open-drain MOSFETs. These open-drain MOSFETs are controlled by setting the WLSx bits in register 0x1C. The WLSx pins are electrically protected from overcurrent by detecting an excessive voltage between WLSx and WSSx pins. Overcurrent fault bits, WSSx\_OC, are located in register 0x0F. If a fault is detected then the WLSx pins stop sinking current. Reading these registers clears the fault bits after the fault is removed.

The sensed voltage difference between the WSSx and WLSx pins provides the current encoded sensor information to the wheel-speed logic. The WSSx pins are electrically protected from short-to-battery and short-to-ground. These conditions are reported by reading the WSSx\_OC and WSSx\_FAULT bits in register 0x0F.

If a fault occurs on WLSx, the path of the sensor to ground is removed. This type of fault must be cleared by following a specific procedure to prevent an overcurrent fault from being erroneously reported. To clear this fault, first disable the WSPx pins, re-enable the WLSx pins, and finally re-enable the WSPx pins. The main purpose for this procedure is to first provide a ground path for the sensor before providing power. Other types of faults can be cleared in the normal way, as long as the WLSx pins are enabled. Table 5-9 lists more information about wheel-speed faults.

**Table 5-9. Wheel-Speed Sense Fault and Operation**

| SYSTEM EVENT                          | FAULT BITS AFFECTED         | TPIC7218-Q1                     |                                   | NOTES  |
|---------------------------------------|-----------------------------|---------------------------------|-----------------------------------|--|
|                                       |                             | PRIOR TO EVENT                  | POST EVENT                        |  |
| VDD Undervoltage                      | PORn = 1                    | WSPx ON<br>WLSx ON<br>WSSQx ON  | WSPx OFF<br>WLSx OFF<br>WSSQx OFF | All of the enable bits for these functions are cleared. nRST is driven low.  |
| VBAT Overvoltage<br>( $>V_{OVVBAT}$ ) | FOV = 1                     | WSPx ON<br>WLSx ON<br>WSSQx ON  | WSPx OFF<br>WLSx OFF<br>WSSQx OFF | All of the enable bits for these functions are cleared   |
| nRST pin externally driven low        | Erst = 1                    | WSPx ON<br>WLSx ON<br>WSSQx ON  | WSPx OFF<br>WLSx OFF<br>WSSQx OFF | All of the enable bits for these functions are cleared   |
| Overcurrent in WSPx                   | WSPx <sub>ILIMIT</sub> = 1  | WSPx ON<br>WLSx ON<br>WSSQx ON  | WSPx OFF<br>WLSx ON<br>WSSQx ON   | WSSQx and WLSx remain on but no wheel-speed output is produced because the sensor has no power. The enable bits for WSPx remain 1  |
| Overcurrent in WSSx-WLSx              | WSSx <sub>OC</sub> = 1      | WSPx ON<br>WLSx ON<br>WSSQx ON  | WSPx ON<br>WLSx OFF<br>WSSQx ON   | WSPx and WSSQx remain on but no wheel-speed output is produced because the sensor has no ground. The enable bits for WLSx remain 1 |
| Overcurrent in WSSQx                  | WSSQx <sub>ILIMIT</sub> = 1 | WSPx ON<br>WLSx ON<br>WSSQx ON  | WSPx ON<br>WLSx ON<br>WSSQx OFF   | WLSx and WSPx remain on. The enable bits for WSSQx remain 1  |
| Short to VBAT on WSPx                 | WSPx_VBAT = 1               | WSPx OFF<br>WLSx ON<br>WSSQx ON | WSPx OFF<br>WLSx ON<br>WSSQx ON   | This fault is detected only while WSPx are OFF. WLSx and WSSQx remain unaffected while WSPx is on and shorted to VBAT.             |
| Short to GND on WLSx                  | WSSx <sub>FAULT</sub> = 1   | WSPx ON<br>WLSx ON<br>WSSQx ON  | WSPx ON<br>WLSx ON<br>WSSQx ON    | WSSQx and WSPx remain on; wheel-speed outputs may be produced but the wheel-speed ground path is not through TPIC7218-Q1 anymore   |
| Short to GND on WSSQx                 | WSSQx <sub>FAULT</sub> = 1  | WSPx ON<br>WLSx ON<br>WSSQx OFF | WSPx ON<br>WLSx ON<br>WSSQx OFF   | This fault is detected only while WSSQx are off. WSPx and WLSx remain on and wheel-speed outputs can still be observed.            |

The wheel-speed internal equivalent model, shown in Figure 5-7 and Figure 5-8, describe how this functional block works. Users need only select a wheel-speed sensor, current sense resistor,  $R_{LOAD}$ , and  $V_{REF}$  voltage for basic operation. The wheel-speed functionality is designed to accommodate both Active and Intelligent sensors; the  $WSS_{TYPE}$  bit in register 0x1D must be set appropriately.

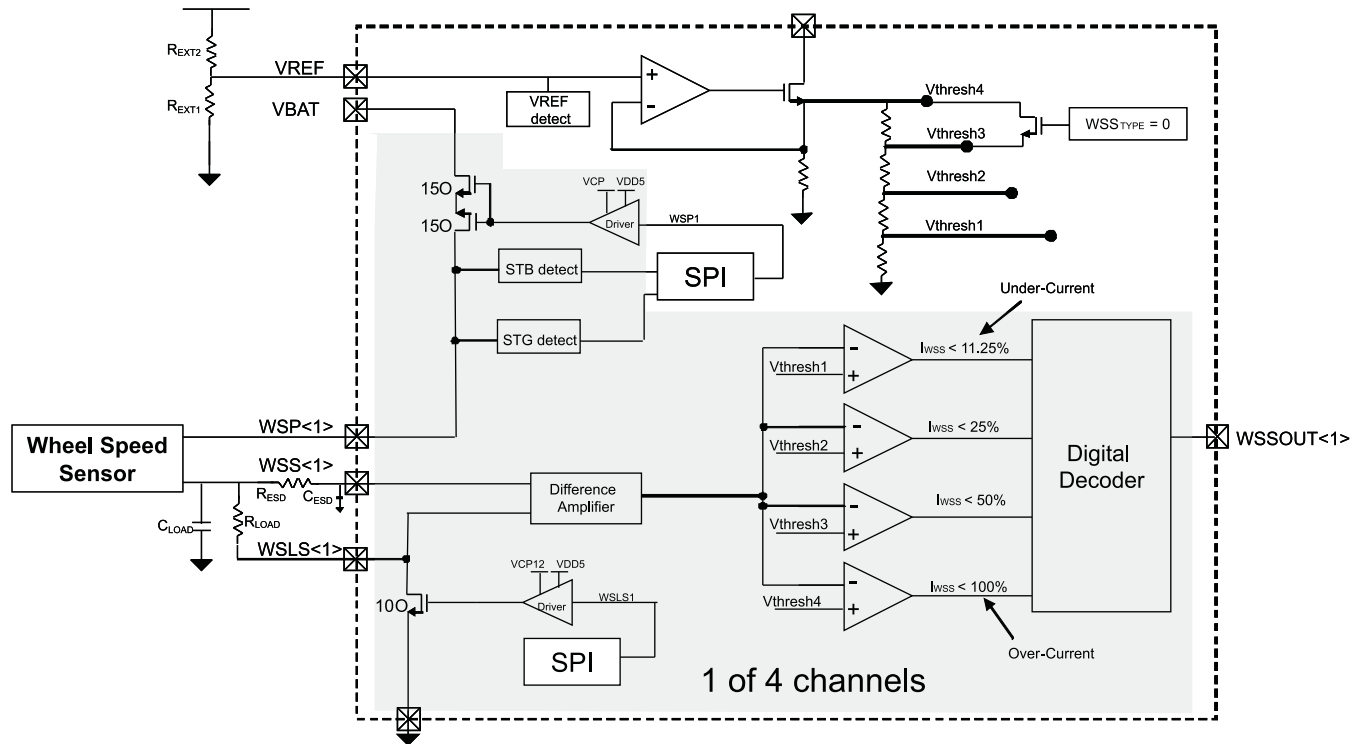

Figure 5-7. Internal Diagram Using Intelligent Type Sensor ( $Wss_{TYPE} = 0$ )

Table 5-10. Intelligent Sensor Wheel-Speed Thresholds

| THRESHOLD     | SIGNIFICANCE  | PERCENTAGE OF MAXIMUM THRESHOLD <sup>(1)</sup> |
|---------------|---|--|
| $V_{THRESH4}$ | $I_{SENSOR} > I_{THRESH4}$<br>Overcurrent (possible short to battery)             | 100% (40 mA)                                   |
| $V_{THRESH3}$ | $I_{THRESH4} > I_{SENSOR} > I_{THRESH3}$<br>Rotational Wheel-Speed Logic- High    | 50% (20 mA)                                    |
| $V_{THRESH2}$ | $I_{THRESH3} > I_{SENSOR} > I_{THRESH2}$<br>Diagnostic sensor Information (9-bit) | 25% (10 mA)                                    |
| $V_{THRESH1}$ | $I_{SENSOR} < I_{THRESH1}$<br>Undercurrent (possible short to ground)             | 11.25% (4.5 mA)                                |

(1) The current is based on maximum of 40 mA,  $R_{LOAD}$  OF 50  $\Omega$ , and  $V_{REF}$  of 2 V

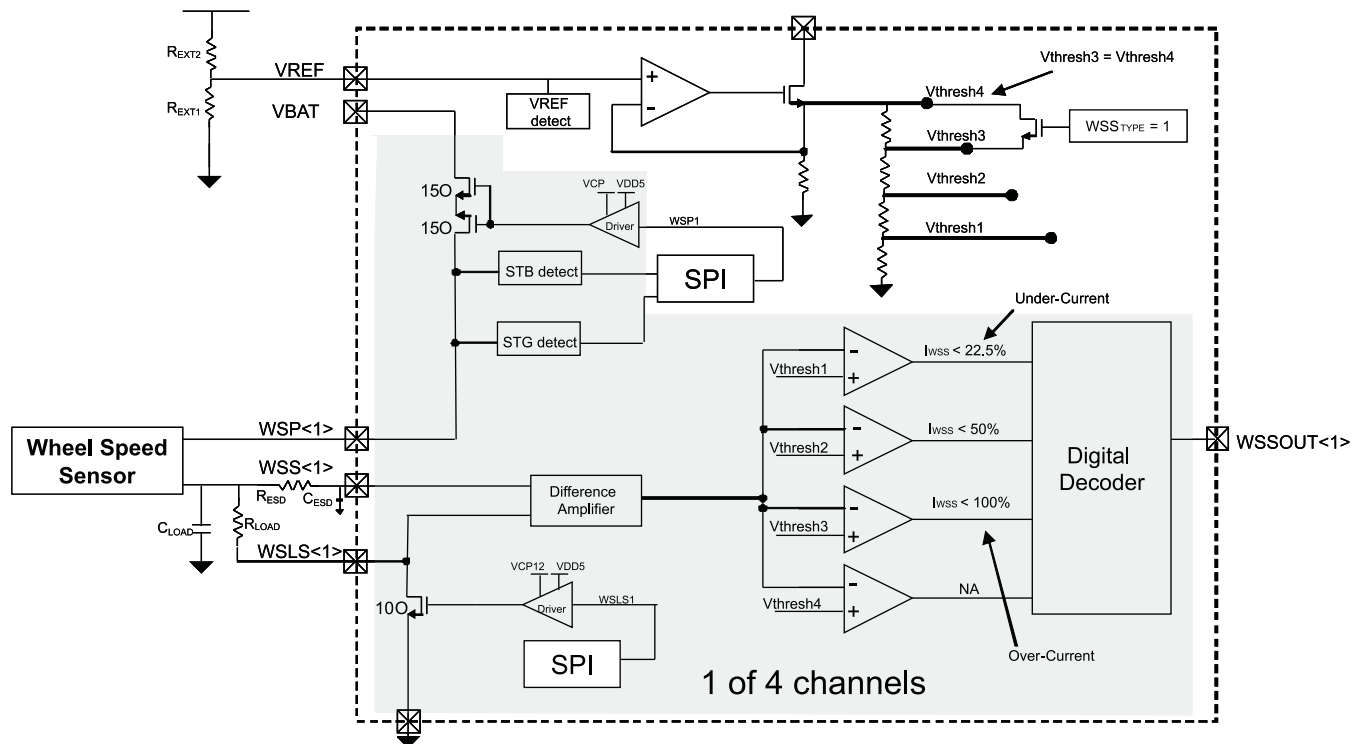

Figure 5-8. Internal Diagram Using Active Type Sensor (WSS<sub>TYPE</sub> = 1)

Table 5-11. Active Sensor Wheel-Speed Thresholds

| THRESHOLD            | SIGNIFICANCE  | PERCENTAGE OF MAXIMUM THRESHOLD <sup>(1)</sup> |
|----------------------|---|--|
| V <sub>THRESH4</sub> | I <sub>SENSOR</sub> > I <sub>THRESH4</sub><br>*Not used   | 100% (20 mA)<br>*Not used                      |
| V <sub>THRESH3</sub> | I <sub>SENSOR</sub> > I <sub>THRESH3</sub><br>Overcurrent (possible short to battery)                   | 100% (20 mA)                                   |
| V <sub>THRESH2</sub> | I <sub>THRESH3</sub> > I <sub>SENSOR</sub> > I <sub>THRESH2</sub><br>Rotational wheel-speed logic- high | 50% (10 mA)                                    |
| V <sub>THRESH1</sub> | I <sub>SENSOR</sub> < I <sub>THRESH1</sub><br>Undercurrent (possible short to ground)                   | 22.5% (4.5 mA)                                 |

(1) The current is based on maximum of 40 mA, R<sub>LOAD</sub> OF 50 Ω, and V<sub>REF</sub> of 2 V.

Both types of sensors provide information based on varying current levels. The TPIC7218-Q1 device provides a way to select different current thresholds by adjusting a voltage on the V<sub>REF</sub> pin. Internally, the voltage on V<sub>REF</sub> governs all four thresholds in a ratio metric manner. V<sub>REF</sub> voltage actually sets the maximum threshold (100%), then, all the other thresholds are automatically set. Intelligent sensors require I<sub>THRESH4</sub> to be set to the maximum threshold, I<sub>WSS(overcurrent)</sub>, and Active sensors require I<sub>THRESH3</sub> to be set to the maximum threshold. For both Intelligent sensors (requiring four thresholds) and Active sensors (requiring three thresholds) use Equation 4 to select a value for V<sub>REF</sub>.

$$V_{REF} = R_{LOAD} * I_{WSS(over-current)} \quad (4)$$

For example, a typical Intelligent wheel-speed sensor may have a maximum typical current less than 40 mA. This 40-mA current must be set to correspond to  $V_{THRESH4}$  (100%). If the value of  $R_{LOAD}$  is selected as 50  $\Omega$ , then the resulting  $V_{REF}$  voltage is calculated to be 2 V. Similarly, a typical Active wheel-speed sensor may have a maximum typical current less than 20 mA. This 20-mA current must be set to correspond to  $V_{THRESH3}$  (100%). However, by setting the  $WSS_{TYPE}$  bit, the digital decoder uses  $V_{THRESH3}$  threshold to actually determine if an overcurrent condition is occurring. By effectively removing the  $V_{THRESH4}$  resistor in the comparator resistor chain, shown in Figure 5-9, a  $V_{REF}$  voltage of 2.4 V and an  $R_{LOAD}$  of 120  $\Omega$ , are needed to properly set the current thresholds. The ratio of the resistor chain did not change, however the current threshold detection levels did. See Figure 5-9 for more detail.

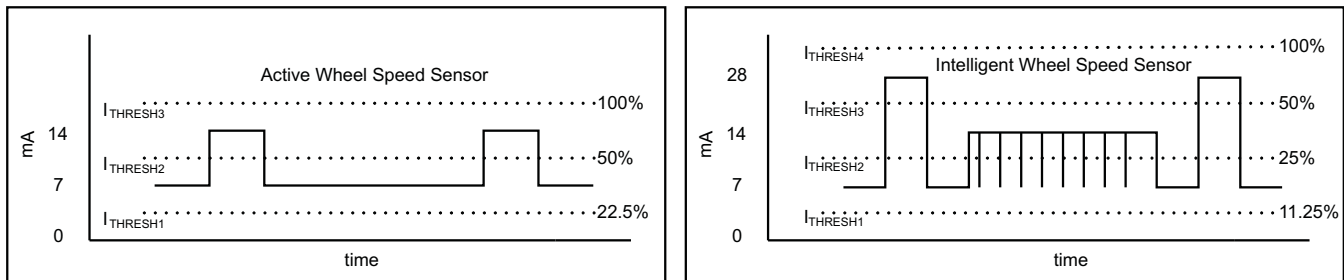

Figure 5-9. Example Wheel-Speed Current Pulse Diagram

While selecting  $R_{LOAD}$  and  $V_{REF}$ , care must be taken so that all electrical specification values are not violated. When the maximum current threshold is selected, the other three thresholds are automatically set.

During normal operation, the  $WSSOUTx$  pins provide a digital signal that is high whenever sensor current creates a voltage drop across  $R_{Load}$  that is above the  $V_{THRESH3}$  level for intelligent sensors and  $V_{THRESH2}$  level for Active sensors. If the current is less than these respective thresholds, the  $WSSOUTx$  pins return to ground. The  $WSSQ1$  and  $WSSQ2$  pins are open-drain outputs that reproduce signals on the  $WSSOUT1$  and  $WSSOUT2$  pins after a propagation delay time of  $t_{wss\_delay}$ . A high level on  $WSSOUT1$  or  $WSSOUT2$  results in low level on  $WSSQ1$  or  $WSSQ2$  pin. These two pins are useful for providing wheel-speed information in a high voltage signal form. The  $WSSQ1$  and  $WSSQ2$  pins also have short-to-ground and open-load detection functionality. The  $WSSQx_{FAULT}$  and  $WSSQx_{LIMIT}$  bits in register 0x05 report these faults and are cleared by reading them after the removal of the fault condition. During an overcurrent fault the  $WSSQ1$  and  $WSSQ2$  pins remain enabled for a time of  $t_{delay\_WSSQx}$ . After this time these pins are disabled.

The TPIC7218-Q1 device also features an 8-bit wheel-speed pulse counter. This counter increments on every rising and falling edge of a selected  $WSSOUTx$ . A MUX selects which the  $WSSOUTx$  signal is input to the counter; bits  $WS\_Cnt\_MUX[1]$  and  $WS\_Cnt\_MUX[0]$  program the MUX as listed in Table 5-12. Count data is reported in register 0x04. A high on the  $CNT\_EN$  pin allows the counter to increment. A high on the  $CNT\_CLR$  pin forces the counter to reset to 0. The count value is available for read through SPI at any point. If the counter is allowed to reach maximum value, the count value remains at maximum but an overflow bit,  $WSS\_OV\_Cnt$  is set. If both  $CNT\_CLR$  and  $CNT\_EN$  pins are in a high logic state then the  $WS\_Fail\_Cnt$  bit is set. These bits clear on read after the fault conditions have been removed.

Table 5-12. Wheel-Speed Counter Input

| WS_Cnt_MUX[1] | WS_Cnt_MUX[0] | SELECTED INPUT |
|---------------|---------------|----------------|
| 0             | 0             | WSSOUT1        |
| 1             | 0             | WSSOUT2        |
| 0             | 1             | WSSOUT3        |
| 1             | 1             | WSSOUT4        |

When the TPIC7218-Q1 device is paired with VDA protocol compatible Intelligent wheel-speed sensors, additional functionality for processing and reporting diagnostic information can be enabled. Diagnostic encoded data (Manchester encoded) in the form of current pulses reaching the  $I_{THRESH2}$  (10 mA) threshold are decoded and placed in the WSSxDx bits. All nine bits are available for reading. If any of the (nine) bit pulse widths were outside the allowed pulse width range (36  $\mu$ s to 64  $\mu$ s including variations) then the pulse widths are not counted as valid. As each of the nine bits are input, only valid bits cause the WSSx\_Valid counter to increment. In this way information about bit errors, or fewer than nine bits being sent from the sensor is recorded and available for each wheel-speed channel. The TPIC7218-Q1 device also contains logic to determine when a new 9-bit frame has started to be input. When detected, the WSSx\_New bit is set. If the wheel-speed sensor is in *stand still mode* then the TPIC7218-Q1 device detects this current pulse activity, resulting in the WSS\_MODE bit being set. Both of these bits can be cleared upon read.

### 5.3.10 K-Line

The TPIC7218-Q1 device includes a serial communication transceiver for K-Line. K-Line provides a bi-directional half-duplex interface for automotive diagnostic communication with data transfer rates of up to 10.4 kbps. The integrated transceiver conforms to the ISO-9141 standard and meets the on-board diagnostic (OBD) requirements of the California Air Resources Board (CARB). For more information on the K-Line protocol see the complete K-Line standard.

Features of the K-Line module include the following:

- ISO-K operates over a wide signal voltage range and is capable of driving high currents.
- ISO-K pin can tolerate a parasitic capacitance of up to 10 nF.
- ISO-K pin is electrically protected to withstand short-to-ground and overcurrent faults.
- The driver stage of the ISO-K pin is thermally protected. A temperature fault disables the bus. Thermal protection also includes hysteresis and blank time before restarting.
- KRx and KTx directly interface to both 5-V and 3.3-V microprocessors without the need for pullup resistors.
- K-Line continues to function regardless of any TPIC7218-Q1 fault conditions with the exception of VDD undervoltage reset condition which powers down the entire TPIC7218-Q1 device.

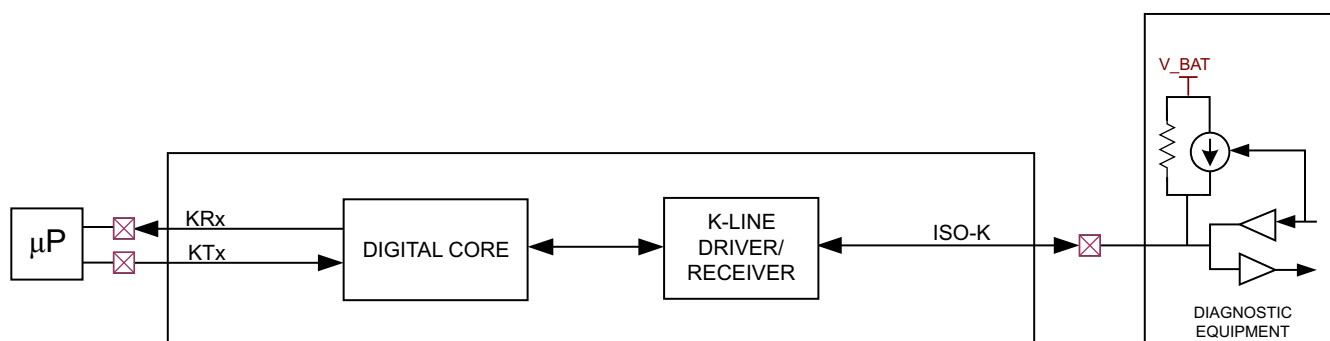

Figure 5-10. K-Line Application Schematic

### 5.3.11 Warning Lamp Drivers

The TPIC7218-Q1 device features three output pins for warning lamps. The WLQ1 and WLQ2 pins are high voltage low-side drivers. The WL\_LS pin is a low voltage low-side driver.

The WL\_LS driver enables whenever the watchdog controlled bit, WD\_STAT, is high. This low-side driver is an open-drain MOSFET; to realize a high logic level and external pullup resistor must be used. Driver operation is only dependent on a watchdog fault.

The WLQ1 driver enables whenever the WLG1 pin and the GE\_9 bit is set. The WLQ2 driver works in the same way utilizing the WLG2 pin and the GE\_10 bit. Each driver is monitored for three fault conditions: overcurrent, open-load, and over-temperature. However, driver operation also depends on other fault conditions: VDD undervoltage, and watchdog fault. See the application circuit and register diagram in Figure 5-11.

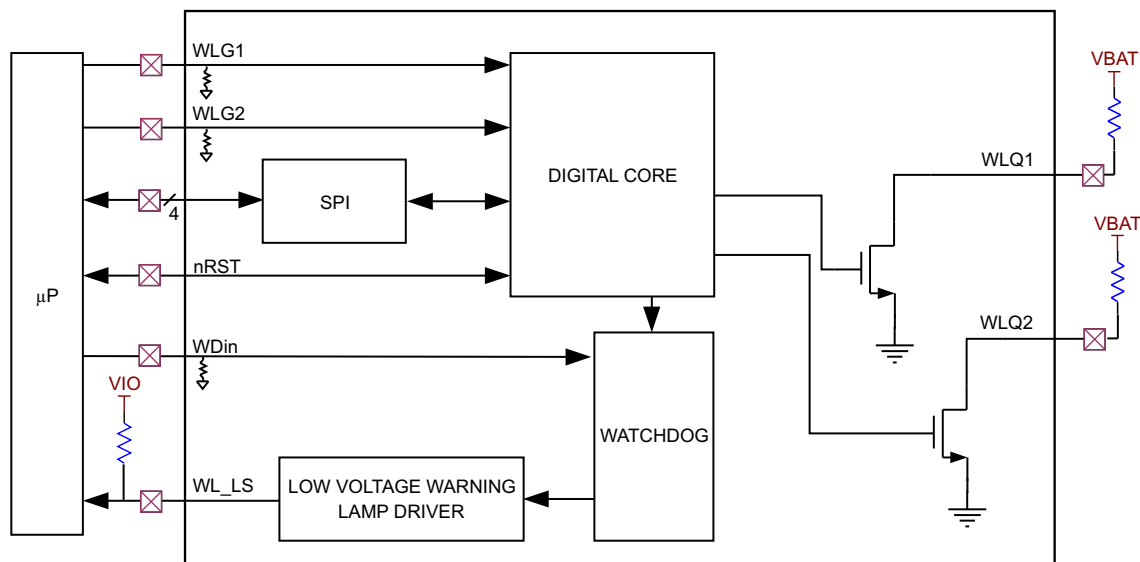

**Figure 5-11. Warning Lamp Driver Register and Application Circuit Diagram**

Each digital driver monitors, reports, and has integrated protection for many electrical fault conditions. Overcurrents are reported as a 1 in register 0x03, (bits 0 and 2 are referenced by bits F9, F10) and do not cause the affected driver to disable. Overcurrents are merely reported after a deglitch time of  $t_{off\_blank\_WLQx}$ . Over-temperature (junction) faults are reported in register 0x03, (bit-6 OTSD) and cause both drivers to disable after a deglitch time of  $t_{off\_tmp\_WLQx}$ . The high-voltage warning-lamp drivers are also checked for an open-load or short to ground condition whenever they are not enabled. This type of fault causes register 0x03, (bits 1 and 3 are referenced by bits S9 and S10) to be reported as a 1. A master low-side fault bit in register 0x00, (bit-0) becomes high whenever an overcurrent or open-load fault occurs. Faults can be cleared by reading the appropriate fault reporting register. When this occurs, the low-side master fault bit (FAIL) can be cleared by reading it.

The high-voltage warning-lamp drivers also respond to fault conditions within other functional blocks. These drivers are disabled whenever the VDD undervoltage fault bit in register 0x00 is set. Also, a watchdog fault can cause these drivers to disable, if register 0x11, bit-4 (WD\_EN) is set. This bit defaults to 0 upon power up. Any of these faults do not cause the FAIL bit to be set.

Faults can be cleared by reading the appropriate fault reporting register. When this occurs the digital drivers can be re-enabled. Fault reporting bits do not have any affect on these warning lamp drivers; only the actual fault condition causes a driver to disable. Nevertheless, TI recommends clearing the fault bits by reading them before enabling the drivers.

Aside from monitoring and reporting faults, the high-voltage warning-lamp drivers have overvoltage protection circuitry built in. An active-clamp monitors voltage on the pins of these drivers. Voltages larger than  $V_{cl\_WLQx}$  are clamped.

### 5.3.12 Watchdog Operation

The TPIC7218-Q1 device also features watchdog functionality. Watchdog functionality is programmable and can be disabled. This functional block receives clock pulses from an external microprocessor through WDIN pin to verify proper system operation. Whenever a watchdog fault occurs, the low-voltage warning-lamp pin (WL\_LS), the reset pin (nRST), and many of the other functional blocks within the TPIC7218-Q1 device are affected. The TPIC7218-Q1 device can be set to accept a range of different pulse widths for easy connection to most microprocessors.

If watchdog functionality is enabled ( $WD\_EN = 1$ ), the TPIC7218-Q1 logic monitors WDIN pulse widths by counting the number of internal clocks that occur between WDIN rising and falling edges. Two, 2-bit values ( $WDH<1:0>$ ,  $WDL<1:0>$ ) can be adjusted to select the length of a valid window range for a WDIN pulse. Pulse widths inside of this window range are counted as a *good pulse*. A good pulse increments a 3-bit state machine counter by one (WDCNTx bits, in register 0x05). When a counter value of 7 is reached, the status bit, WDSTAT, becomes a 1 and all TPIC7218-Q1 watchdog inhibited functionality is enabled. If a *bad pulse* occurs then the state machine counter is decremented by three. The WD\_FAULT bit is set whenever the counter value is 0, causing the WD\_STAT bit to become low. A fault turns off high-side drivers, low-side drivers, wheel-speed functionality, and high-voltage warning-lamp drivers. Both the low-voltage warning-lamp driver (WL\_LS) and the reset pin (nRST) enables. The SPI continues to function and the WD\_FAULT and WDSTAT bits indicate a watchdog fault. When a full watchdog count is reached, register bits and functionality would return to normal state. Refer to [Figure 5-12](#) through [Figure 5-14](#) for more details on the state transitions and timing.

If the WDIN pin does not realize a transition after twice the length of time selected in the upper window, which is set by bits  $WDH<1:0>$ , then an out-of-range condition occurs. The watchdog fault becomes high and the watchdog status bit becomes low ( $WD\_FAULT = 1$ , and  $WDSTAT = 0$ ).

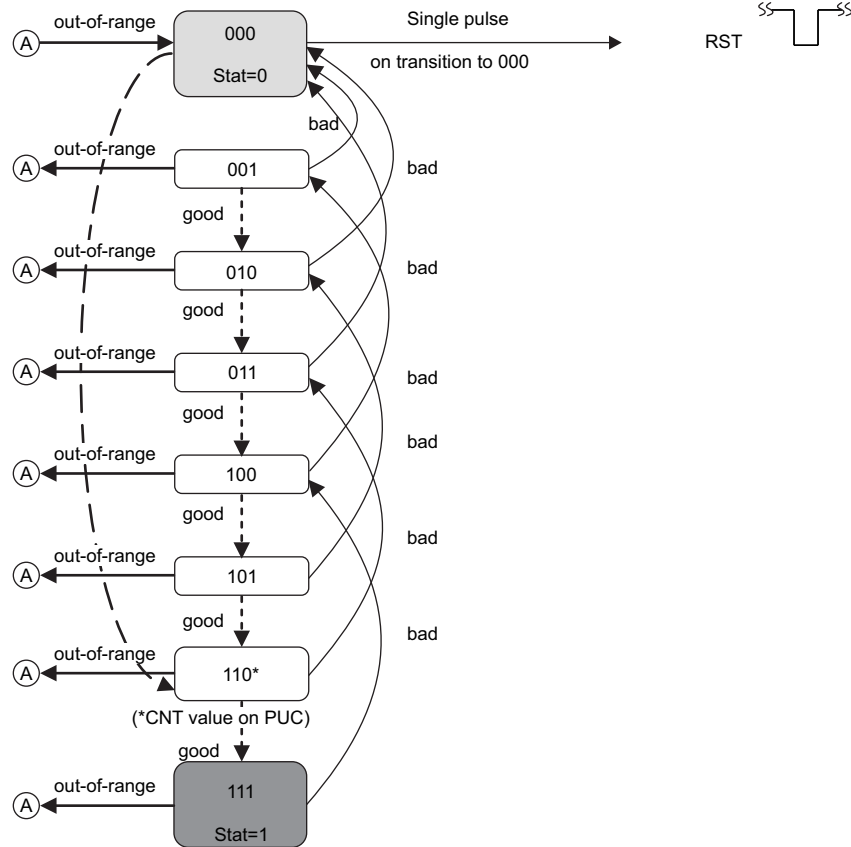

Figure 5-12. Watchdog State Transition Diagram

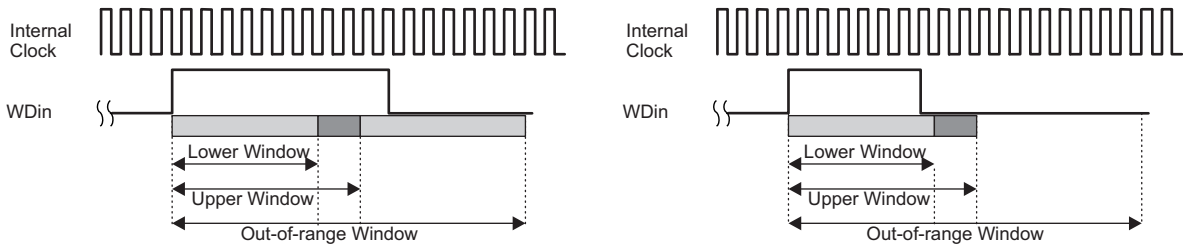

Figure 5-13. Timing Diagram Showing A Bad Pulse

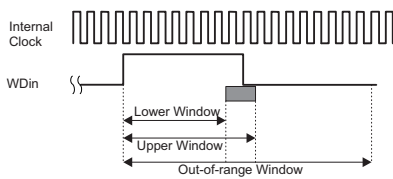

Figure 5-14. Timing Diagram Showing A Good Pulse

## 5.4 Device Functional Modes

The device operates in normal mode as described in [Section 5.3](#) unless it is in the reset state.

### 5.4.1 Device Reset

Several events cause the TPIC7218-Q1 device to reset. For a complete view of TPIC7218-Q1 behavior during reset, refer to [Table 5-1](#).

**Power-On Reset** A power-on reset, POR, is caused when the VDD supply voltage falls below the reset threshold. On POR the nRST pin is pulled low by the TPIC7218-Q1 device.

**Watchdog Reset** A watchdog reset is initiated whenever the Watchdog counter decrements to 000. Upon Watchdog Reset, the nRST pin is pulsed low, and the WDSTAT flag is cleared. As the nRST pin is released, the Watchdog state machine is restarted. The watchdog will re-enable after a delay time  $T_{WD\_PULSE}$  to allow sufficient time for the microcontroller to reset.

**External Reset** An external reset is realized whenever the nRST pin is driven low by an external signal (usually from a microprocessor). When nRST is released the Erst bit is set, indicating that an external reset occurred.

## 5.5 Programming

### 5.5.1 Serial Peripheral Interface (SPI) Interface To Microcontroller

The TPIC7218-Q1 device uses a SPI communication interface. The TPIC7218-Q1 device operates as a slave with full-duplex, synchronous, 8-bit transfer frames. The device can be controlled and monitored in one of three modes: Read, Write, and Dummy. Read command returns data to the master. If a fault register is read, then any faults will be cleared. However, if the fault still exists then the fault reporting bit(s) will remain high. A write command sends data to the slave. Data is latched in on the rising edge of the second chip select. A dummy command is used whenever the master and slave lose synchronization. This happens whenever the master does not issue a normal 16-bit transfer using two eight-bit frames. Dummy commands essentially reset the SPI logic to the default state.

A typical SPI operation contains two full chip select frames; each containing eight clock pulses. All SPI transaction starts when CSN transitions to a logic low. During this time 8-bits of mode, R/W, and address data are clocked into SI. Finally, the CSN returns high, concluding the first half of the normal transaction. The second half of the normal transaction starts when CSN again transitions to a logic low. During this time 8-bits of data are clocked into SI. Finally, the CSN returns high, and a normal SPI transaction is concluded. If one chip-select frame does not have exactly eight clocks, then the whole 16-bit transaction is considered invalid and is ignored. The CSN must go high for a window of 2  $\mu$ s to 28  $\mu$ s ( $CSN_{timeout}$ ) between two 8-bit commands for the 16-bit command to be considered valid. A 16-bit read command consists of an 8-bit read command of the intended address and an 8-bit dummy command. The SPI can also operate in burst mode, whereby consecutive 8-bit read commands result in a consecutive 8-bit data being returned to the master.

**Table 5-13. SPI Instruction Encoding**

| MODE   | R/W <sub>n</sub> | STAT. | A[5] | A[4] | A[3] | A[2] | A[1] | A[0] |
|--------|------------------|-------|------|------|------|------|------|------|
| Unused | 0                | 1     | A[5] | A[4] | A[3] | A[2] | A[1] | A[0] |
| Read   | 1                | 0     | A[5] | A[4] | A[3] | A[2] | A[1] | A[0] |
| Write  | 0                | 0     | A[5] | A[4] | A[3] | A[2] | A[1] | A[0] |
| Dummy  | 1                | 1     | X    | X    | X    | X    | X    | X    |

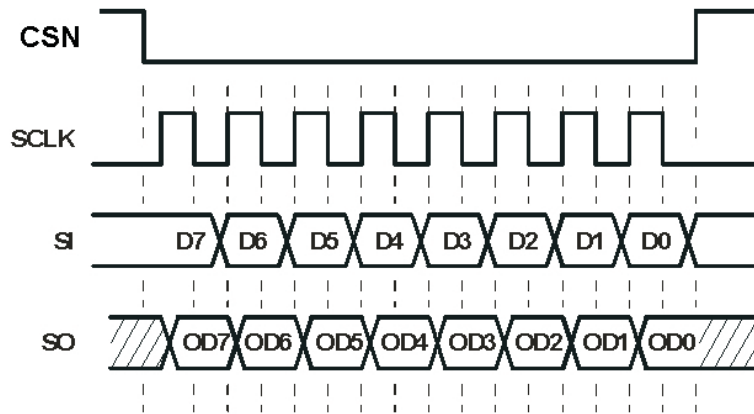

Figure 5-15. One Chip-Select Frame

The SO pin contains the register data in response to the previous eight bit frame. Data out is always delayed by one SPI transfer (for example, response to the command N is shifted out at the same time command N+1 is shifted in). Valid data is shifted out from the SO pin on the rising edge of SCLK. The response to the SPI frame depends on which type of transaction mode is requested by the Master (read, write, or dummy).

If the SPI transaction is valid, the Slave determines what type of operation is being requested. If a Read transaction is requested, the Slave responds with the Read byte during the next SPI transaction. Figure 5-16 shows the SPI Read operation.

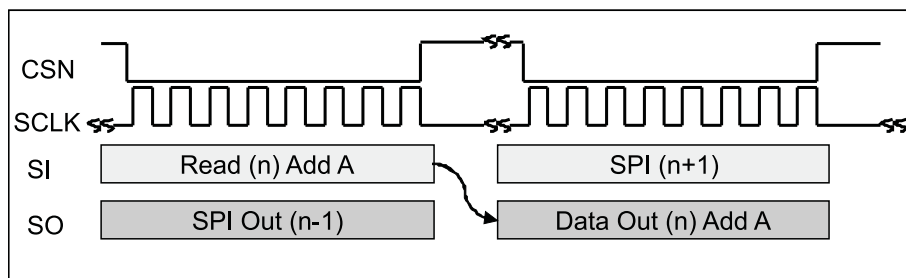

Figure 5-16. One Chip-Select Frame

A Write operation places the data byte into the address specified in the previous chip select frame.

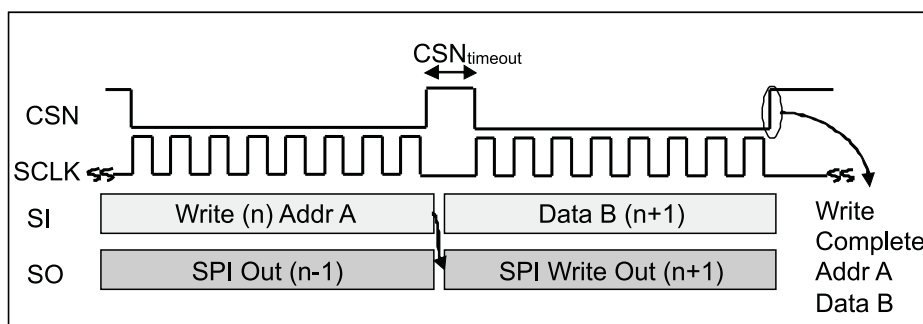

Figure 5-17. One Chip-Select Frame

### 5.5.1.1 Summary and Description Of Control and Reporting Registers

The TPIC7218-Q1 device contains 30 registers that contain both fault reporting and control bits. Refer to the following tables for register map and functional description of each bit.

## 5.6 Register Maps

### 5.6.1 SPI Registers

Table 5-14. SPI Registers Map

| ADDRESS | R/W   | b7           | b6           | b5          | b4          | b3             | b2             | b1            | b0            |
|---------|-------|--------------|--------------|-------------|-------------|----------------|----------------|---------------|---------------|
| 0x00    | R     | HSDC2        | FHSD         | FOV         | FUV         | Erst           | HSDC1          | PORn          | FAIL          |
| 0x01    | R     | S4           | F4           | S3          | F3          | S2             | F2             | S1            | F1            |
| 0x02    | R     | S8           | F8           | S7          | F7          | S6             | F6             | S5            | F5            |
| 0x03    | R     | WS_OV_Cnt    | OTSD         | WS_Fail_Cnt | KI          | S10            | F10            | S9            | F9            |
| 0x04    | R     | WS_Cnt_OUT7  | WS_Cnt_OUT6  | WS_Cnt_OUT5 | WS_Cnt_OUT4 | WS_Cnt_OUT3    | WS_Cnt_OUT2    | WS_Cnt_OUT1   | WS_Cnt_OUT0   |
| 0x05    | R     | WSSQ2_ILIMIT | WSSQ1_ILIMIT | WSSQ2_FAULT | WSSQ1_FAULT | WDSTAT         | WDCNT2         | WDCNT1        | WDCNT0        |
| 0x06    | R     | VLD_DEG      | OCPR         | STGPR       | FGPR        | LMR            | FGMR           | STGMR         | OCMR          |
| 0x07    | R     | WSS1D7       | WSS1D6       | WSS1D5      | WSS1D4      | WSS1D3         | WSS1D2         | WSS1D1        | WSS1D0        |
| 0x08    | R     | WSS1_Valid3  | WSS1_Valid2  | WSS1_Valid1 | WSS1_Valid0 | WSP1_STB       | WSS1_Mode      | WSS1_New      | WSS1D8        |
| 0x09    | R     | WSS2D7       | WSS2D6       | WSS2D5      | WSS2D4      | WSS2D3         | WSS2D2         | WSS2D1        | WSS2D0        |
| 0x0A    | R     | WSS2_Valid3  | WSS2_Valid2  | WSS2_Valid1 | WSS2_Valid0 | WSP2_STB       | WSS2_Mode      | WSS2_New      | WSS2D8        |
| 0x0B    | R     | WSS3D7       | WSS3D6       | WSS3D5      | WSS3D4      | WSS3D3         | WSS3D2         | WSS3D1        | WSS3D0        |
| 0x0C    | R     | WSS3_Valid3  | WSS3_Valid2  | WSS3_Valid1 | WSS3_Valid0 | WSP3_STB       | WSS3_Mode      | WSS3_New      | WSS3D8        |
| 0x0D    | R     | WSS4D7       | WSS4D6       | WSS4D5      | WSS4D4      | WSS4D3         | WSS4D2         | WSS4D1        | WSS4D0        |
| 0x0E    | R     | WSS4_Valid3  | WSS4_Valid2  | WSS4_Valid1 | WSS4_Valid0 | WSP4_STB       | WSS4_Mode      | WSS4_New      | WSS4D8        |
| 0x0F    | R     | WSS4_OC      | WSS3_OC      | WSS2_OC     | WSS1_OC     | WSS4_FAULT     | WSS3_FAULT     | WSS2_FAULT    | WSS1_FAULT    |
| 0x10    | RW    | GE8          | GE7          | GE6         | GE5         | GE4            | GE3            | GE2           | GE1           |
| 0x11    | RW    | WD_Fault     | 0            | OV_GMR      | WD_EN       | GE_PR          | GE_MR          | GE10          | GE9           |
| 0x12    | RW    | WDH<1>       | WDH<0>       | WDL<1>      | WDL<0>      | PWM_Freq1      | PWM_Freq0      | WS_Cnt_MUX[1] | WS_Cnt_MUX[0] |
| 0x13    | RW    | PWM_Q5<7>    | PWM_Q5<6>    | PWM_Q5<5>   | PWM_Q5<4>   | PWM_Q5<3>      | PWM_Q5<2>      | PWM_Q5<1>     | PWM_Q5<0>     |
| 0x14    | RW    | 0            | 0            | 0           | 0           | PWMQ5_Phase<1> | PWMQ5_Phase<0> | PWM_Q5<9>     | PWM_Q5<8>     |
| 0x15    | RW    | PWM_Q6<7>    | PWM_Q6<6>    | PWM_Q6<5>   | PWM_Q6<4>   | PWM_Q6<3>      | PWM_Q6<2>      | PWM_Q6<1>     | PWM_Q6<0>     |
| 0x16    | RW    | 0            | 0            | 0           | 0           | PWMQ6_Phase<1> | PWMQ6_Phase<0> | PWM_Q6<9>     | PWM_Q6<8>     |
| 0x17    | RW    | PWM_Q7<7>    | PWM_Q7<6>    | PWM_Q7<5>   | PWM_Q7<4>   | PWM_Q7<3>      | PWM_Q7<2>      | PWM_Q7<1>     | PWM_Q7<0>     |
| 0x18    | RW    | 0            | 0            | 0           | 0           | PWMQ7_Phase<1> | PWMQ7_Phase<0> | PWM_Q7<9>     | PWM_Q7<8>     |
| 0x19    | RW    | PWM_Q8<7>    | PWM_Q8<6>    | PWM_Q8<5>   | PWM_Q8<4>   | PWM_Q8<3>      | PWM_Q8<2>      | PWM_Q8<1>     | PWM_Q8<0>     |
| 0x1A    | RW    | 0            | 0            | 0           | 0           | PWMQ8_Phase<1> | PWMQ8_Phase<0> | PWM_Q8<9>     | PWM_Q8<8>     |
| 0x1B    | RW    | 0            | WSSP4        | WSSP3       | WSSP2       | WSSP1          | WSS_TYPE       | WSSQ2         | WSSQ1         |
| 0x1C    | RW    | OCPR_DIS     | STGPR_DIS    | OCMR_DIS    | STGMR_DIS   | WSLS4          | WSLS3          | WSLS2         | WSLS1         |
| 0x1D    | RW/R* | VREF_OK*     | FGPR_DIS     | FGMR_DIS    | LMR_DIS     | WSP4_ILIMIT    | WSP3_ILIMIT*   | WSP2_ILIMIT*  | WSP1_ILIMIT*  |

**Table 5-15. Description Of Control and Reporting Bits**

| BIT NAME    | DESCRIPTION   |
|-------------|---|
| Fail        | Any fault on any digital or PWM low-side driver<br>0 = Fault not detected<br>1 = Fault detected   |
| PORn        | Power-on reset. Reset low when read by microcontroller.<br>0 = No power-on reset detected. Reset to this value when read by microcontroller.<br>1 = Power-on reset detected           |
| HSDC1       | High-side driver comparator1 for Master Relay (MR)<br>0 = Comparator output low<br>1 = Comparator output high   |
| Erst        | RST pin is pulled low by external source<br>0 = Fault not detected<br>1 = Fault detected  |
| Fuv         | Undervoltage on V <sub>BAT</sub><br>0 = Fault not detected<br>1 = Fault detected  |
| Fov         | Overvoltage on V <sub>BAT</sub><br>0 = Fault not detected<br>1 = Fault detected   |
| FHSD        | Any fault on the high-side drivers (either GMR or GPR). If set, this bit is latched until Address 6 is read. Then, it clears on read.<br>0 = Fault not detected<br>1 = Fault detected |
| HSDC2       | High-side driver comparator 2 for Master Relay (MR)<br>0 = Comparator output low<br>1 = Comparator output high  |
| Sx          | Open-load fault on the low-side output (S9 reports WLQ1 fault and S10 reports WLQ2 fault)<br>0 = Fault not detected on output x<br>1 = Fault detected on output x                     |
| Fx          | Short-to-battery fault on the low-side output (F9 reports WLQ1 fault and F10 reports WLQ2 fault)<br>0 = Fault not detected on output x<br>1 = Fault detected on output x              |
| WS_Fail_Cnt | CNT_EN and CNT_CLR set at the same time<br>0 = Fault not detected<br>1 = Fault detected   |
| KI          | Status bit for Kline current limit condition<br>0 = Fault not detected<br>1 = Fault detected  |
| OTSD        | Any overtemperature fault<br>0 = Fault not detected<br>1 = Fault detected   |
| WS_OV_Cnt   | Count overflow on the wheel-speed sensor (past 256)<br>0 = Overflow not detected<br>1 = Overflow detected   |

**Table 5-15. Description Of Control and Reporting Bits (continued)**

| BIT NAME   | DESCRIPTION   |
|--|---|
| WSSx_Valid4<br>WSSx_Valid3<br>WSSx_Valid2<br>WSSx_Valid1 | This word shows the valid number of bits in each wheel-speed channel.   |
| WDCNT0<br>WDCNT1<br>WDCNT2                               | Status Bit 1 of three that is used to track the operation of the watchdog circuit (LSB)<br>Status Bit 2 of three that is used to track the operation of the watchdog circuit<br>Status Bit 3 of three that is used to track the operation of the watchdog circuit (MSB) |
| WDSTAT   | Watchdog status bit<br>0 = Out-of-range<br>1 = In-range   |
| WSSQ1 <sub>FAULT</sub>                                   | Open load or short to ground on WSSQ1<br>0 = Fault not detected<br>1 = Fault detected   |
| WSSQ2 <sub>FAULT</sub>                                   | Open load or short to ground on WSSQ2<br>0 = Fault not detected<br>1 = Fault detected   |
| WSSQ1 <sub>ILIMIT</sub>                                  | Overcurrent on WSSQ1<br>0 = Fault not detected<br>1 = Fault detected  |
| WSSQ2 <sub>ILIMIT</sub>                                  | Overcurrent on WSSQ2<br>0 = Fault not detected<br>1 = Fault detected  |
| OCMR   | Overcurrent fault on MR<br>0 = Fault not detected<br>1 = Fault detected   |
| STGMR  | Short-to-ground fault on MR<br>0 = Fault not detected<br>1 = Fault detected   |
| FGMR   | GMR disabled by external circuitry<br>0 = GMR not disabled<br>1 = GMR disabled  |
| LMR  | Load-leakage fault on MR (Master Relay)<br>0 = Fault not detected<br>1 = Fault detected   |
| FGPR   | GPR disabled by external circuitry<br>0 = GPR not disabled<br>1 = GPR disabled  |
| STGPR  | Short-to-ground fault on PR<br>0 = Fault not detected<br>1 = Fault detected   |
| OCPR   | Overcurrent fault on PR<br>0 = Fault not detected<br>1 = Fault detected   |
| VLD <sub>DEG</sub>                                       | This bit is a replica of FOV  |
| WSS1Dx   | VDA data bits for wheel-speed channel 1   |

**Table 5-15. Description Of Control and Reporting Bits (continued)**

| BIT NAME    | DESCRIPTION  |
|-------------|--|
| WSS2Dx      | VDA data bits for wheel-speed channel 2  |
| WSS3Dx      | VDA data bits for wheel-speed channel 3  |
| WSS4Dx      | VDA data bits for wheel-speed channel 4  |
| WSSx_New    | Flag bits that notify the availability of new data for each sensor channel<br>1 = new data since last read was performed<br>0 = old data since last read was performed                                 |
| WSSx_Mode   | Flag bits that notify the mode of operation for each sensor channel<br>1 = standstill mode<br>0 = normal mode  |
| WSPx_STB    | Flag bits that show a short to battery for each sensor channel in the off state<br>1 = short to battery<br>0 = normal operation  |
| WS_Cnt_OUT7 | Bit 7 of wheel-speed counter (value latched at CSN low-to-high transition)   |
| WS_Cnt_OUT6 | Bit 6 of wheel-speed counter   |
| WS_Cnt_OUT5 | Bit 5 of wheel-speed counter   |
| WS_Cnt_OUT4 | Bit 4 of wheel-speed counter   |
| WS_Cnt_OUT3 | Bit 3 of wheel-speed counter   |
| WS_Cnt_OUT2 | Bit 2 of wheel-speed counter   |
| WS_Cnt_OUT1 | Bit 1 of wheel-speed counter   |
| WS_Cnt_OUT0 | Bit 0 of wheel-speed counter   |
| WSSx_FAULT  | Open load or short to ground on WSSx pins<br>0 = Fault not detected<br>1 = Fault detected  |
| WSSx_OC     | Overcurrent fault on WSSx pins<br>0 = Fault not detected<br>1 = Fault detected   |
| GE1         | Enable and disable digital driver 1. It does not clear on Q1 fault   |
| GE2         | Enable and disable digital driver 2. It does not clear on Q2 fault   |
| GE3         | Enable and disable digital driver 3. It does not clear on Q3 fault   |
| GE4         | Enable and disable digital driver 4. It does not clear on Q4 fault   |
| GE5         | Enable and disable digital driver 5. It does not clear on Q5 fault   |
| GE6         | Enable and disable digital driver 6. It does not clear on Q6 fault   |
| GE7         | Enable and disable digital driver 7. It does not clear on Q7 fault   |
| GE8         | Enable and disable digital driver 8. It does not clear on Q8 fault   |
| GE9         | Enable and disable warning lamp driver 1. It does not clear on WLQ1 fault  |
| GE10        | Enable and disable warning lamp driver 2. It does not clear on WLQ2 fault  |
| GE_MR       | Enable and disable Master Relay (GMR). It clears on fault  |
| GE_PR       | Enable and disable pump motor relay (GPR). It clears on fault  |
| WD_EN       | Watchdog state machine enable.<br>1 = Enabled; Q1-Q8, GMR, GPR cannot be turned on unless WDSTAT =1<br>0 = Disabled; Q1-Q8, GMR, GPR can be controlled independent of WDstat. (WDSTAT =0 when WD_EN=0) |
| OV_GMR      | Configure the response of GMR FET during overvoltage condition<br>0 = Maintain the previous state<br>1 = Disable GMR FET   |

**Table 5-15. Description Of Control and Reporting Bits (continued)**

| BIT NAME                     | DESCRIPTION   |
|------------------------------|---|
| WD_FAULT                     | Status bit that latches the watchdog fault WDSTAT=0. It clears on read and it is a read only bit<br>1 = watchdog fault has happened (WDSTAT =0)<br>0 = no watchdog fault has happened (WDSTAT =1) |
| WS_Cnt_MUX1<br>WS_Cnt_MUX0   | Control bit 1 for wheel-speed sensor multiplexer<br>Control bit 0 for wheel-speed sensor multiplexer  |
| PWM <sub>Freq</sub> <1:0>    | Control bits to set the PWM frequency   |
| WDH<1:0>                     | Control bits to set the watchdog upper window range<br>00 = 64 ms<br>01 = 32 ms<br>10 = 16 ms<br>11 = 8 ms  |
| WDL<1:0>                     | Control bits to set the watchdog lower window range<br>00 = 32 ms<br>01 = 16 ms<br>10 = 8 ms<br>11 = 4 ms   |
| PWM <sub>Qx</sub> <9:0>      | Control bits to set the duty cycle of each PWM channel. When changing from one duty cycle setting to another, the new setting takes place in the next period.                                     |
| PWM <sub>Qx</sub> Phase<1:0> | Control bits to set the phase shift for the PWM drivers<br>00=0°<br>01=90°<br>10=180°<br>11=270°  |
| WSSQ1                        | Enable and disable wheel-speed output WSSQ1. It clears only on VBAT overvoltage fault   |
| WSSQ2                        | Enable and disable wheel-speed output WSSQ1. It clears only on VBAT overvoltage fault   |
| WSS <sub>TYPE</sub>          | Type of sensor used<br>1 = Active<br>0 = Intelligent  |
| WSP <sub>x</sub>             | Control bit for the supply of the wheel-speed sensor. It clears only on VBAT overvoltage fault<br>1 = ON<br>0 = OFF   |
| WSL <sub>Sx</sub>            | Control bit for the supply return of the wheel-speed sensor. It clears only on VBAT overvoltage fault<br>1 = ON<br>0 = OFF  |
| STGMR <sub>DIS</sub>         | Enable and disable MR short-to-ground protection (STGMR)<br>0 = Disabled (default after reset)<br>1 = Enabled   |
| OCMR <sub>DIS</sub>          | Enable and disable MR overcurrent protection (OCMR)<br>0 = Disabled (default after reset)<br>1 = Enabled  |
| STGPR <sub>DIS</sub>         | Enable and disable PR short-to-ground protection (STGPR)<br>0 = Disabled (default after reset)<br>1 = Enabled   |
| OCPR <sub>DIS</sub>          | Enable and disable PR overcurrent protection (OCPR)<br>0 = Disabled (default after reset)<br>1 = Enabled  |

**Table 5-15. Description Of Control and Reporting Bits (continued)**

| BIT NAME                | DESCRIPTION   |
|-------------------------|---|
| WSP <sub>X</sub> ILIMIT | Current limit fault on WSP <sub>X</sub> pins (read only bits)<br>0 = Fault not detected<br>1 = Fault detected   |
| LMR <sub>DIS</sub>      | Enable and disable MR leakage protection (LMR)<br>0 = Disabled (default after reset)<br>1 = Enabled   |
| VREF <sub>OK</sub>      | Status bit that indicates if V <sub>REF</sub> pin is more than 0.75 V (read only)<br>0 = V <sub>REF</sub> pin is less than 0.75 V<br>1 = V <sub>REF</sub> pin is more than 0.75 V |

## 6 Application and Implementation

### NOTE

Information in the following applications sections is not part of the TI component specification, and TI does not warrant its accuracy or completeness. TI's customers are responsible for determining suitability of components for their purposes. Customers should validate and test their design implementation to confirm system functionality.

### 6.1 Application Information

The TPIC7218-Q1 device, as typically used in anti-lock braking systems, requires very few external components; thus, the design is quite simple.

### 6.2 Typical Application

A simplified application diagram of the TPIC7218-Q1 device [Figure 6-1](#) shows a simplified application diagram.

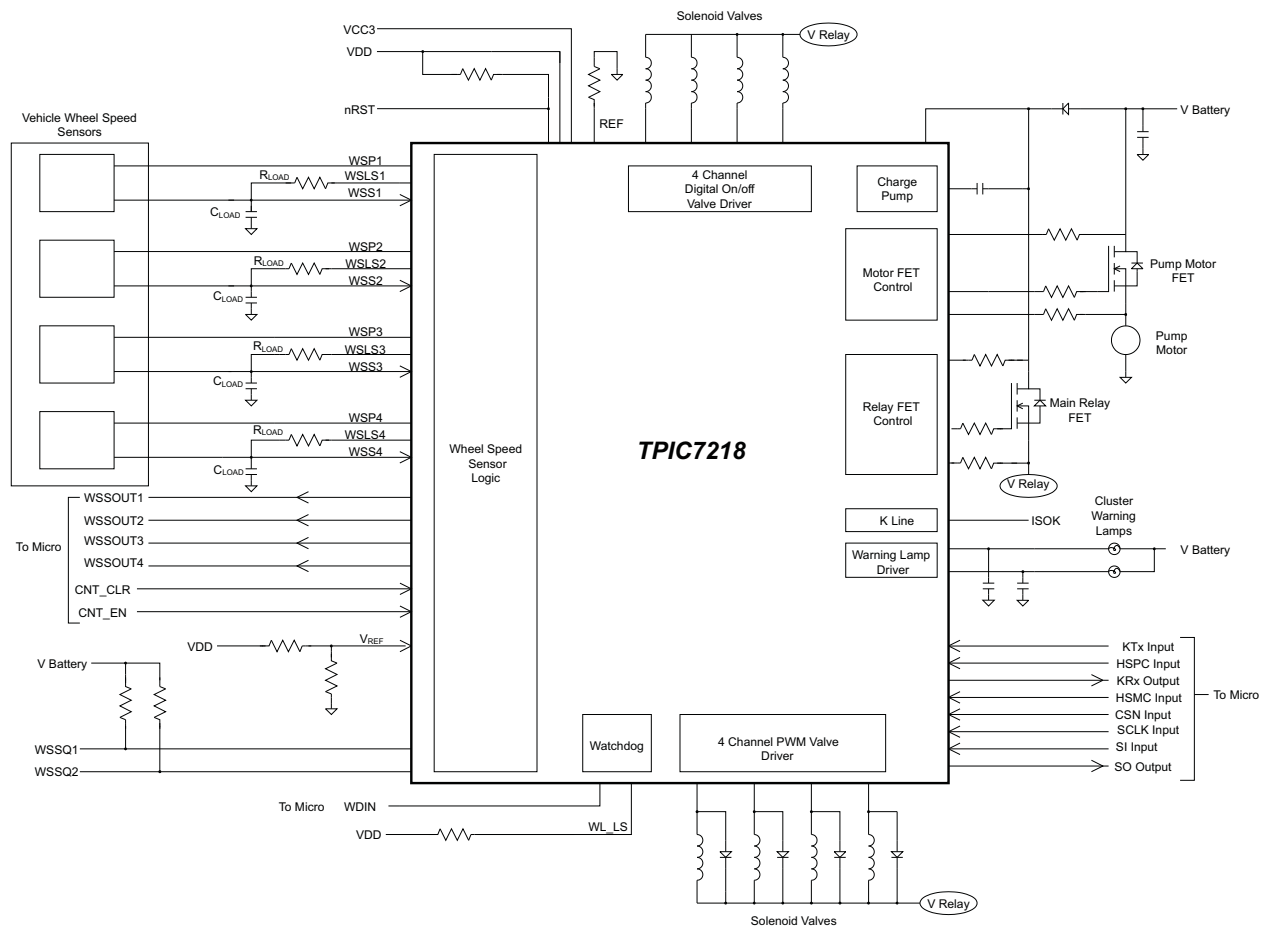
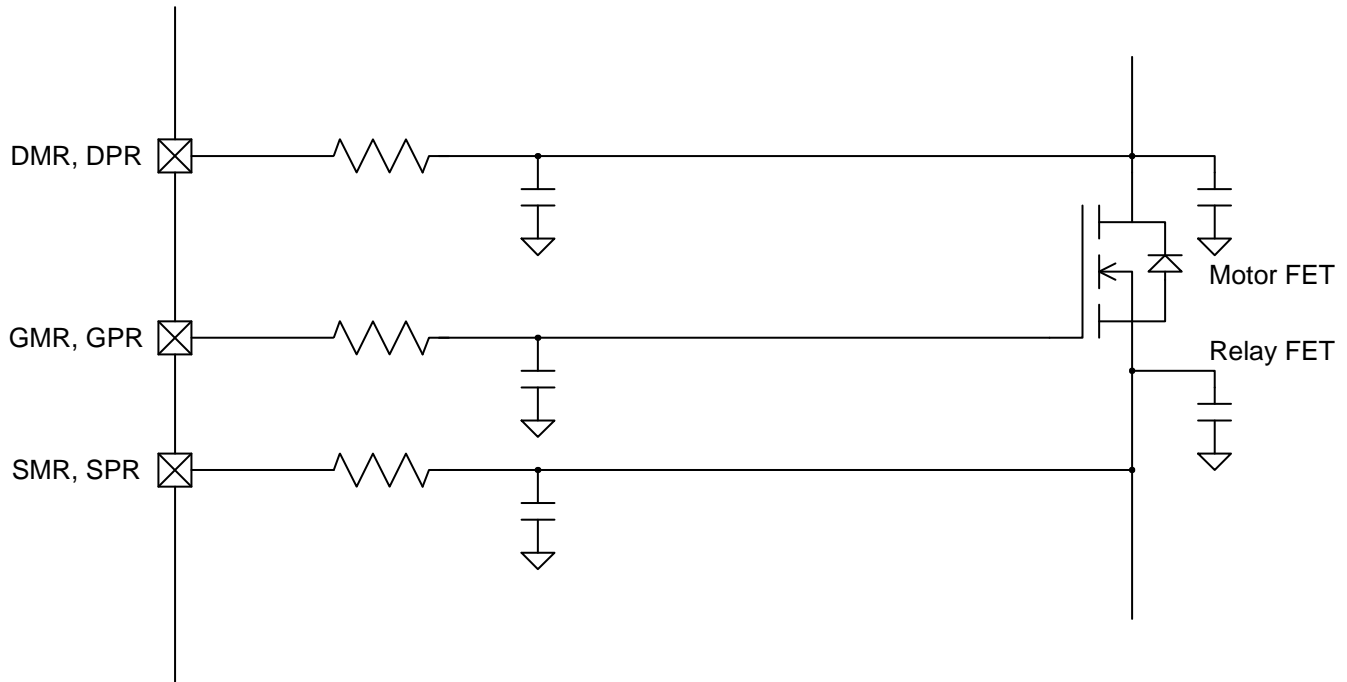

Figure 6-1. Simplified Application Diagram

#### 6.2.1 Design Requirements

The design of the components needed for the wheel speed sensor interface (VREF voltage and  $R_{LOAD}$ ) is described in [Section 5.3.9](#). The only other major design requirement is in choice of the resistors connected to pins controlling the pump relay (PR) and main relay (MR) FETs as shown in [Figure 6-2](#). The choice of these resistors is described in [Section 6.2.2](#).



**Figure 6-2. xPR and xMR Resistors in Application Diagram**

## 6.2.2 Detailed Design Procedure

The resistor  $R_{DMR}$  is to be chosen based on the overcurrent detection value needed for the system relay and pump relay as explained in [Section 5.3.8](#).  $R_{SMR}$  resistor value to be chosen to limit the current into the pin in a reverse battery situation - typically in the 1- to 2-k $\Omega$  range. See [Section 6.2.2.1](#) for description of the GMR and GPR resistor design procedure.

### 6.2.2.1 Gatedrive circuit Motor FET

When the pump relay driver at the GPR pin is enabled, it is charged in three different ways. The internal pre-GPR node is shorted to the VBAT supply to give it battery voltage. There are also two current sources that are then enabled at the same time,  $I_{DC\_GPR}$  and  $I_{TRAN\_GPR}$  as shown in [Figure 6-3](#). The  $I_{DC\_GPR}$  current is on any time the pump relay is turned ON. The  $I_{TRAN\_GPR}$  current source is only enabled for a time  $t_{STGPR}$  after the GPR is turned on. The final voltage will not exceed CHP. The maximum charging time can be obtained from the electrical characteristics table. The turnon time is set by the charging currents with the gate resistor not affecting it significantly. A typical turnon timing characteristic is shown in [Figure 6-4](#), in this case with the IPB 80N06S3L-06 chosen as the pump relay FET.

When the pump relay driver is set to the off state all of the charging paths are disabled and the GPR pin is shorted to GND. The external gate resistance is the primary determinant of the turnoff time. The gate resistor should be sized based on the gate characteristics of the chosen FET and the desired turnoff time. A typical turnoff characteristic with a 10-k $\Omega$  resistor is shown in [Figure 6-5](#).

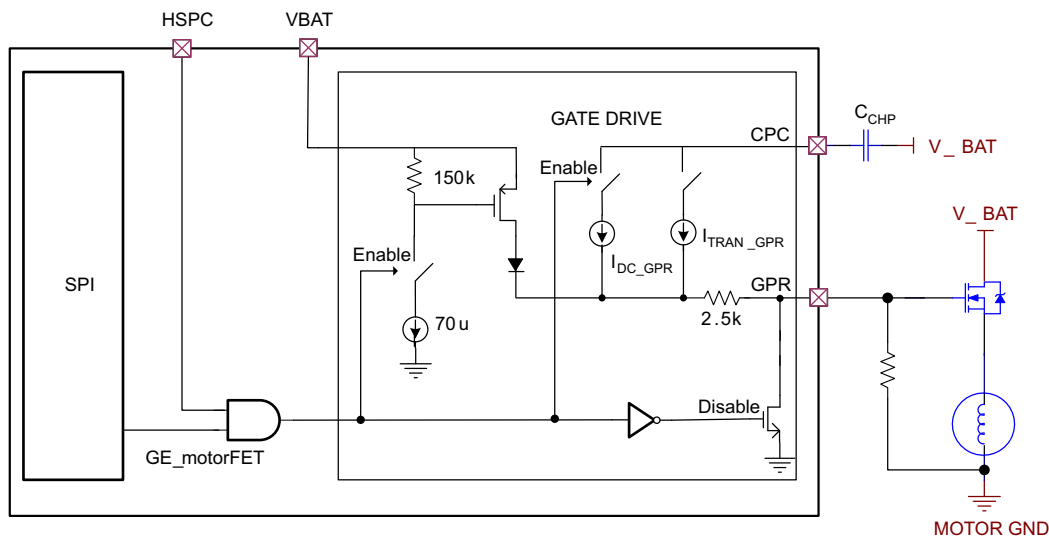
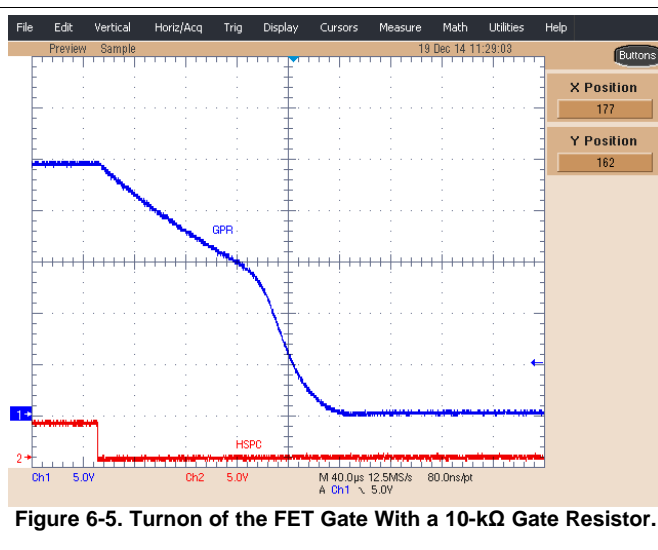
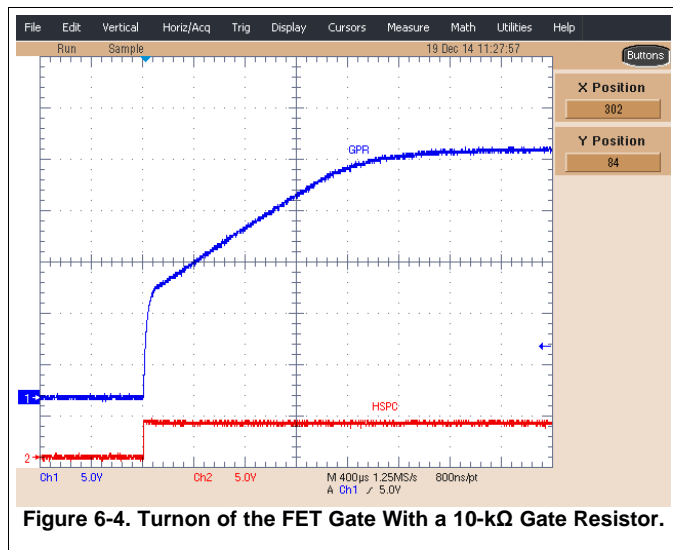

Figure 6-3. Pump Relay Gatedriver Circuit

### 6.2.2.2 Gatedrive circuit Master Relay FET

The circuit used for the gate drive for the master relay FET is similar to the pump motor FET gatedrive with changes in the drive strength as reflected in the turnon times from the electrical characteristics table. The gate resistor for the master relay FET should be chosen using the same procedure as for the pump motor relay driver.

### 6.2.3 Application Curves



## 7 Power Supply Recommendations

The TPIC7218-Q1 device requires three power supply input pins – (1) VBAT connected to the automotive battery, (2) VDD connected to a 5-V regulated output from the battery and (3) VIO which can be optionally connected to VDD or a 3.3-V regulated output. TI recommends that all power supply pins have decoupling capacitors. Use good circuit board layout techniques to ensure each capacitor provides instantaneous peak current to the TPIC7218-Q1 device. Care must be taken to avoid parasitic impedances which can degrade decoupling performance. Poorly decoupled power pins are likely to cause unsatisfactory EMC performance. TI recommends the following capacitor values:

- VBAT: recommended, 0.1  $\mu$ F, X7R, 10%
- VDD: recommended, 0.1  $\mu$ F, X7R, 10%
- VCC3: required, 100 pF, X7R, 10%

## 8 Layout

### 8.1 Layout Guidelines

#### 8.1.1 Local Grounding Configuration

Route the ground pins 6, 24, 29, 30, 31, 32, 37, 63, 64, 69, 70, 71, 72 and 77 directly inward to pad. Maximize plane area under the TPIC7218-Q1 device to be consistent with PCB design rules. Ensure proper relief features for soldering thermal pad to plated through holes.

Add additional plated through holes as shown in the sketch to minimize loop area for ground return currents. See [Figure 8-1](#) for more information.

#### 8.1.2 Board Level Grounding Configuration, TPIC7218-Q1 to System Connector

Ideally the inner PCB layer under the TPIC7218-Q1 device should be dedicated as plane ground, with direct connection to wiring connector pin to vehicle ground. The layer should cover entire PCB area, with only clearance holes for vias and so forth. No breaks or divisions. See [Figure 8-2](#) for more information.

#### 8.1.3 VCC3 Bypass Capacitor

Place 0402 package bypass capacitor for VCC3 node to ground as close as possible to the TPIC7218-Q1 device, absolute minimum loop width and trace length. Do not connect ground side of capacitor to any plane; tie it directly with top layer trace to pin 6 as shown in [Figure 8-3](#). Close placement, minimum loop area is a priority.

#### 8.1.4 VDD Bypass Capacitor

VDD bypass capacitor needs to be close to the TPIC7218-Q1 device, but not as critical as VCC3 cap. The orientation and location shown in [Figure 8-4](#) is just an example. Connection between capacitor and ground node to be made through a through to the inner ground plane layer.

#### 8.1.5 VBAT and CHP Capacitors

Three capacitors are used for bypassing the VBAT node. Prioritize placing an 0402 as close as possible to pin 59. The other two need to be close but not as critical. Ground capacitors. Capacitor ground needs to be connected to inner plane. The 0805 package is suitable for the other two capacitors.

Two capacitors are used between pin 59 and 60, and as with VBAT node, the 0402 capacitor needs to be as close as possible to the TPIC7218-Q1 device. The 0805 package is suitable for the other capacitor. See [Figure 8-5](#) for more information.

### 8.1.6 Multiple Plane Layer Assignments

Place components associated with VCC3 (pin 3), VDD (pin 9), VBAT (pin 59), CHP (pin 60), DMR (pin 55), SMR (pin 56), GMR (pin 57), GPR (pin 58), SPR (pin 61) and DPR (pin 62) on top layer. Assign first PCB layer under the top layer as an overall ground plane.

Placing components on top-side of board and assigning first inner layer as ground plane minimizes the path length and loop area for EMC bypassing. See [Figure 8-6](#) for more information.

### 8.1.7 Duplicate Pad Under TPIC7218-Q1 on All Non-Ground Plane Inner Layers

Duplicate the top layer pad underneath the TPIC7218-Q1 device on all of the inner layers. For the first inner ground plane layer, entire plane is ground except for clearances around holes and unconnected vias. Bottom layer copper pad directly under the TPIC7218-Q1 device is sized and has relief features as required for the thermal slug. See [Figure 8-6](#) for more information.

### 8.1.8 Flooding

Flooding places copper on all available area, subject to the clearance rules for the manufacture of the PCB. Flooded areas should be connected by vias to the inner ground plane layer. Small, insignificant flooded zones may be left unconnected or deleted from the design.

The additional copper connected to ground augments the effectiveness of the inner ground plane layer by providing parallel paths, and also improves heat sink performance by increasing the thermal mass of the PCB. See [Figure 8-7](#) for more information.

## 8.2 Layout Example

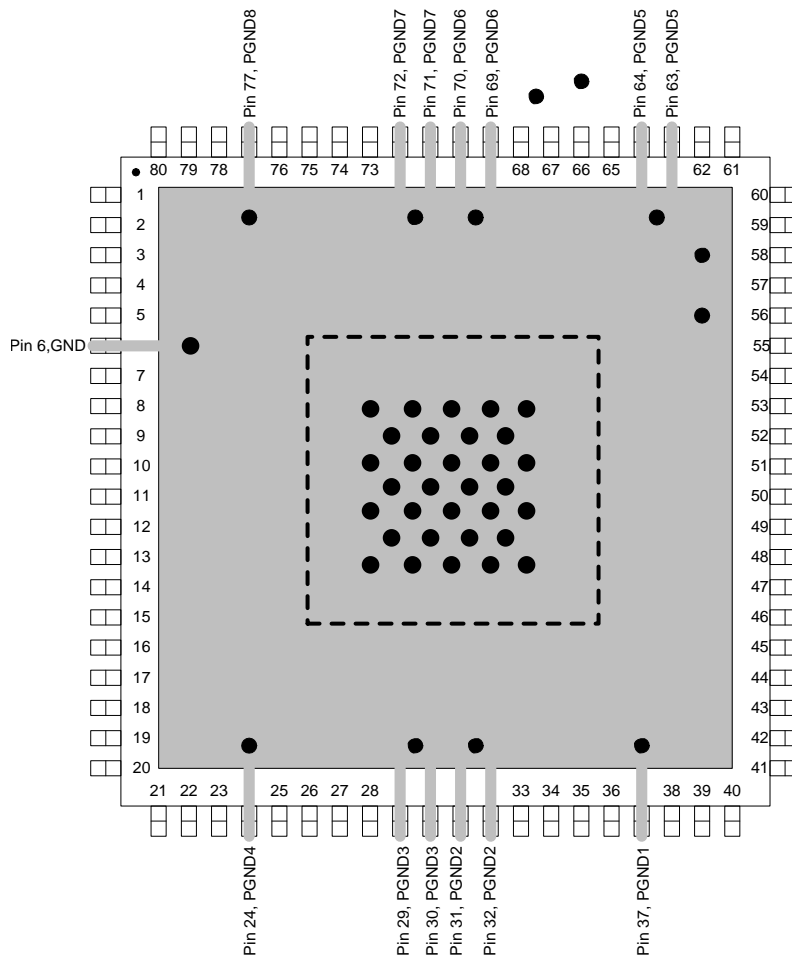

Figure 8-1. Local Grounding Configuration Layout Example

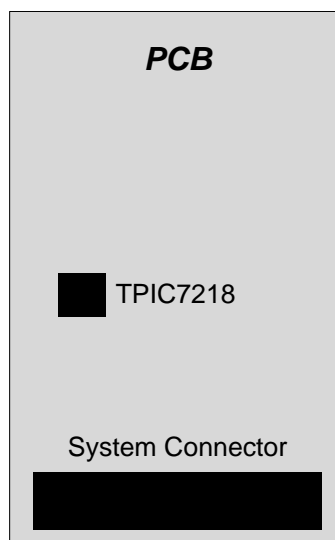

Figure 8-2. Board Level Grounding Configuration, TPIC7218-Q1 to System Connector Layout Example

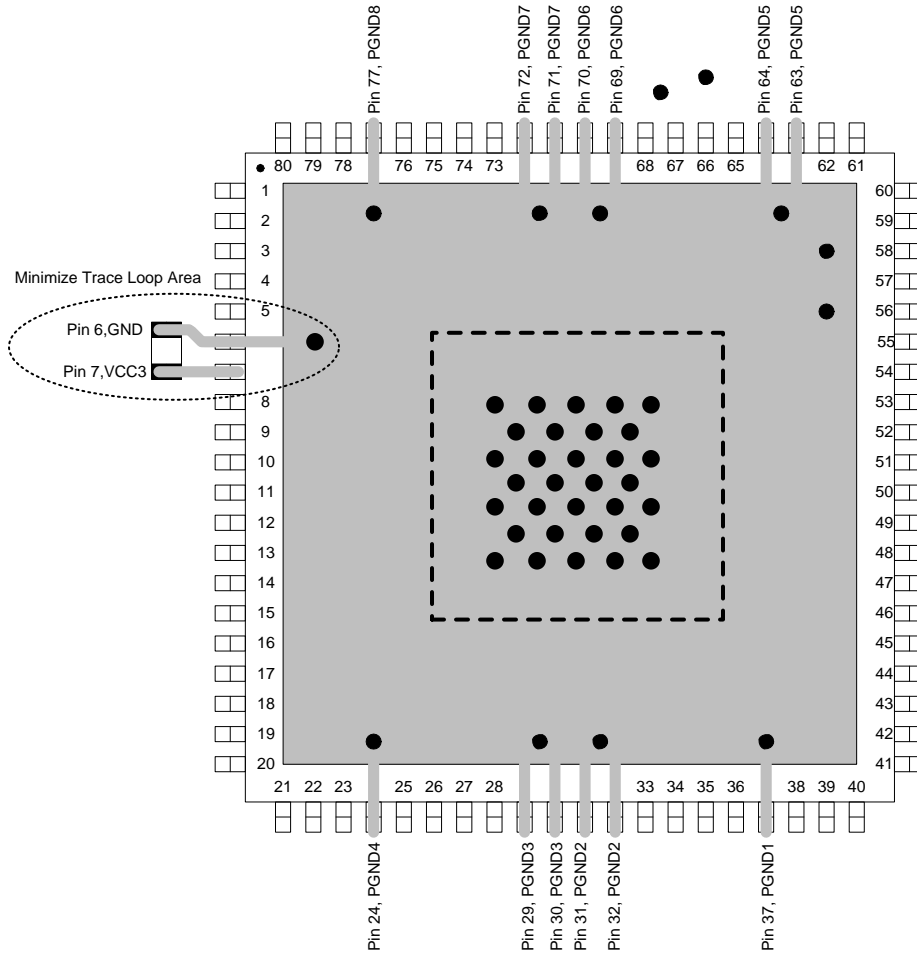
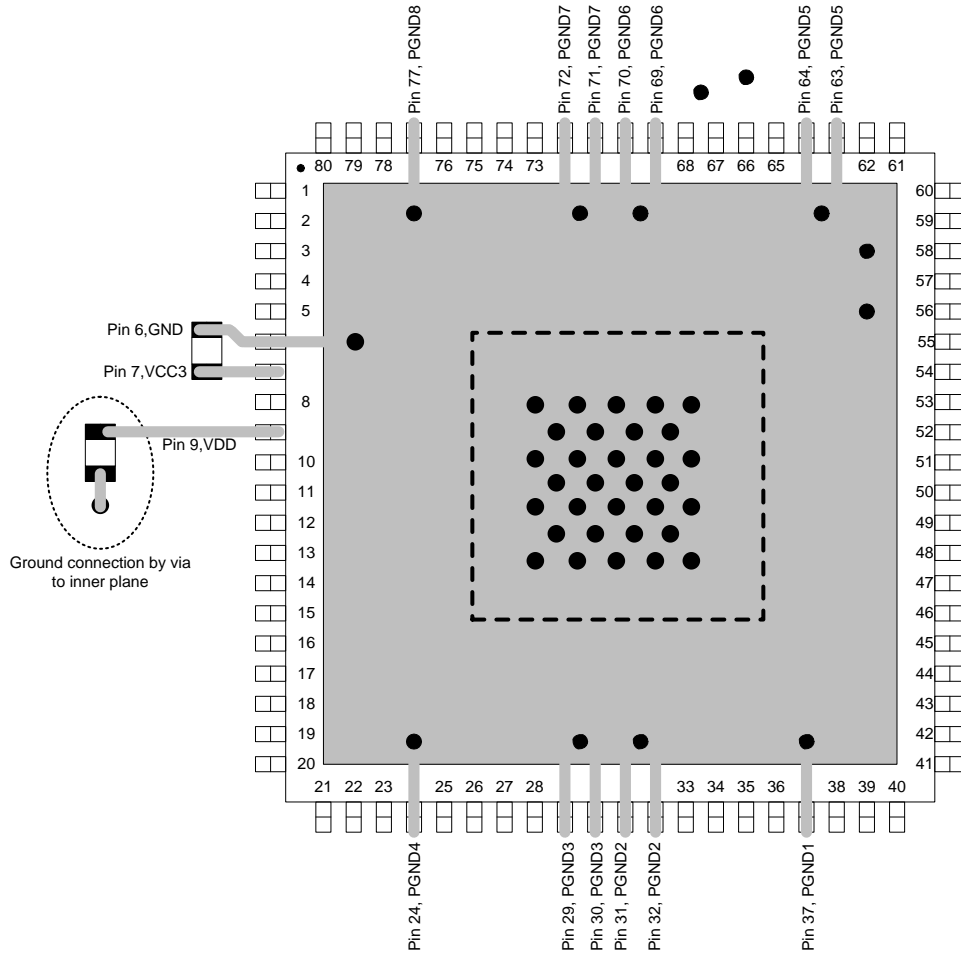

Figure 8-3. VCC3 Bypass Capacitor Layout Example



**Figure 8-4. VDD Bypass Capacitor Layout Example**

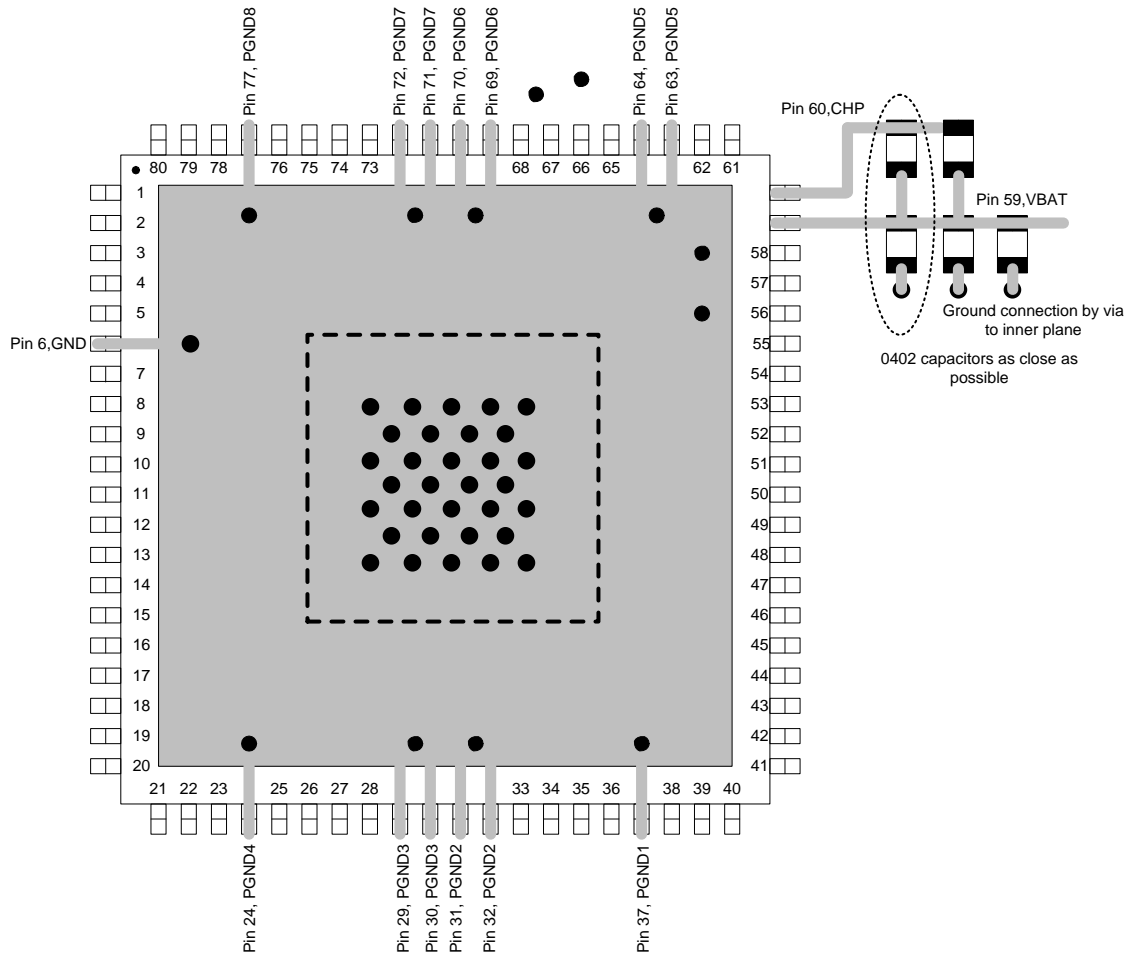

Figure 8-5. VBAT and CHP Capacitors Layout Example

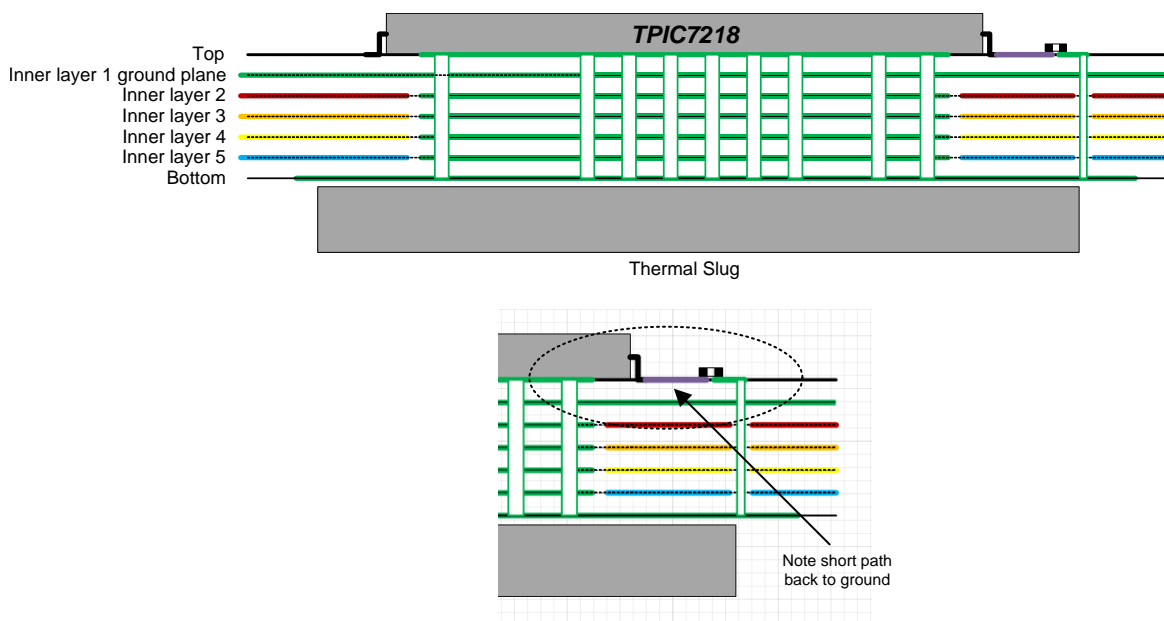

Figure 8-6. Multiple Plane Layer Assignments Layout Example

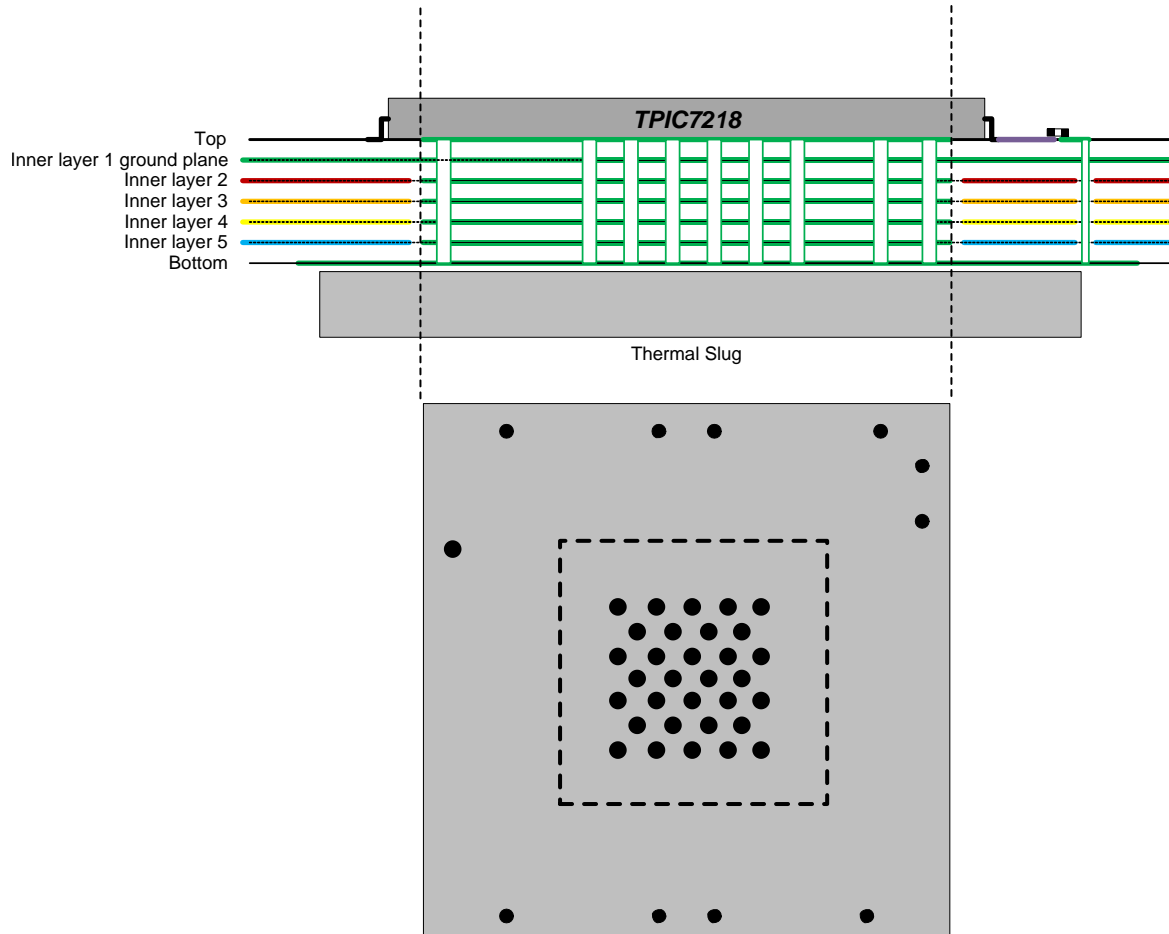

Figure 8-7. Thermal Slug Layout Example

## 9 Device and Documentation Support

### 9.1 Documentation Support

#### 9.1.1 Related Documentation

For related documentation see the following: *TPIC7218-Q1 Thermal Design Considerations and Solution*, [SLDA013](#)

### 9.2 Community Resources

The following links connect to TI community resources. Linked contents are provided "AS IS" by the respective contributors. They do not constitute TI specifications and do not necessarily reflect TI's views; see TI's [Terms of Use](#).

**[TI E2E™ Online Community](#)** *TI's Engineer-to-Engineer (E2E) Community*. Created to foster collaboration among engineers. At [e2e.ti.com](http://e2e.ti.com), you can ask questions, share knowledge, explore ideas and help solve problems with fellow engineers.

**[Design Support](#)** *TI's Design Support* Quickly find helpful E2E forums along with design support tools and contact information for technical support.

### 9.3 Trademarks

PowerPAD, E2E are trademarks of Texas Instruments.  
All other trademarks are the property of their respective owners.

## 9.4 Electrostatic Discharge Caution



These devices have limited built-in ESD protection. The leads should be shorted together or the device placed in conductive foam during storage or handling to prevent electrostatic damage to the MOS gates.

## 9.5 Glossary

[SLYZ022](#) — *TI Glossary*.

This glossary lists and explains terms, acronyms, and definitions.

## 10 Mechanical, Packaging, and Orderable Information

The following pages include mechanical, packaging, and orderable information. This information is the most current data available for the designated devices. This data is subject to change without notice and revision of this document. For browser-based versions of this data sheet, refer to the left-hand navigation.

**PACKAGING INFORMATION**

| Orderable Device | Status<br>(1) | Package Type | Package Drawing | Pins | Package Qty | Eco Plan<br>(2)         | Lead/Ball Finish<br>(6) | MSL Peak Temp<br>(3) | Op Temp (°C) | Device Marking<br>(4/5) | Samples |
|------------------|---------------|--------------|-----------------|------|-------------|-------------------------|-------------------------|----------------------|--------------|-------------------------|---------|
| TPIC7218QFPFRQ1  | ACTIVE        | HTQFP        | FPF             | 80   | 1000        | Green (RoHS & no Sb/Br) | CU NIPDAU               | Level-3-260C-168 HR  | -40 to 125   | TPIC7218Q               | Samples |

(1) The marketing status values are defined as follows:

**ACTIVE:** Product device recommended for new designs.

**LIFEBUY:** TI has announced that the device will be discontinued, and a lifetime-buy period is in effect.

**NRND:** Not recommended for new designs. Device is in production to support existing customers, but TI does not recommend using this part in a new design.

**PREVIEW:** Device has been announced but is not in production. Samples may or may not be available.

**OBSELETE:** TI has discontinued the production of the device.

(2) Eco Plan - The planned eco-friendly classification: Pb-Free (RoHS), Pb-Free (RoHS Exempt), or Green (RoHS & no Sb/Br) - please check <http://www.ti.com/productcontent> for the latest availability information and additional product content details.

**TBD:** The Pb-Free/Green conversion plan has not been defined.

**Pb-Free (RoHS):** TI's terms "Lead-Free" or "Pb-Free" mean semiconductor products that are compatible with the current RoHS requirements for all 6 substances, including the requirement that lead not exceed 0.1% by weight in homogeneous materials. Where designed to be soldered at high temperatures, TI Pb-Free products are suitable for use in specified lead-free processes.

**Pb-Free (RoHS Exempt):** This component has a RoHS exemption for either 1) lead-based flip-chip solder bumps used between the die and package, or 2) lead-based die adhesive used between the die and leadframe. The component is otherwise considered Pb-Free (RoHS compatible) as defined above.

**Green (RoHS & no Sb/Br):** TI defines "Green" to mean Pb-Free (RoHS compatible), and free of Bromine (Br) and Antimony (Sb) based flame retardants (Br or Sb do not exceed 0.1% by weight in homogeneous material)

(3) MSL, Peak Temp. - The Moisture Sensitivity Level rating according to the JEDEC industry standard classifications, and peak solder temperature.

(4) There may be additional marking, which relates to the logo, the lot trace code information, or the environmental category on the device.

(5) Multiple Device Markings will be inside parentheses. Only one Device Marking contained in parentheses and separated by a "~" will appear on a device. If a line is indented then it is a continuation of the previous line and the two combined represent the entire Device Marking for that device.

(6) Lead/Ball Finish - Orderable Devices may have multiple material finish options. Finish options are separated by a vertical ruled line. Lead/Ball Finish values may wrap to two lines if the finish value exceeds the maximum column width.

**Important Information and Disclaimer:**The information provided on this page represents TI's knowledge and belief as of the date that it is provided. TI bases its knowledge and belief on information provided by third parties, and makes no representation or warranty as to the accuracy of such information. Efforts are underway to better integrate information from third parties. TI has taken and continues to take reasonable steps to provide representative and accurate information but may not have conducted destructive testing or chemical analysis on incoming materials and chemicals. TI and TI suppliers consider certain information to be proprietary, and thus CAS numbers and other limited information may not be available for release.

In no event shall TI's liability arising out of such information exceed the total purchase price of the TI part(s) at issue in this document sold by TI to Customer on an annual basis.



## TAPE AND REEL INFORMATION



### QUADRANT ASSIGNMENTS FOR PIN 1 ORIENTATION IN TAPE

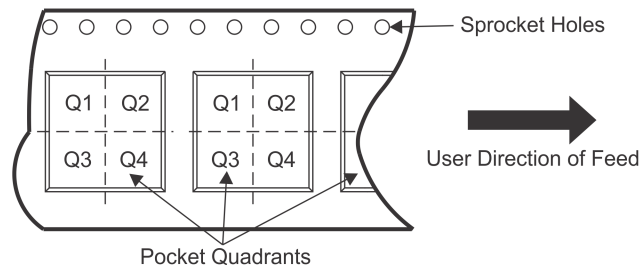

\*All dimensions are nominal

| Device           | Package Type | Package Drawing | Pins | SPQ  | Reel Diameter (mm) | Reel Width W1 (mm) | A0 (mm) | B0 (mm) | K0 (mm) | P1 (mm) | W (mm) | Pin1 Quadrant |
|------------------|--------------|-----------------|------|------|--------------------|--------------------|---------|---------|---------|---------|--------|---------------|
| TPIC7218QPFP RQ1 | HTQFP        | PFP             | 80   | 1000 | 330.0              | 24.4               | 15.0    | 15.0    | 1.5     | 20.0    | 24.0   | Q2            |

**TAPE AND REEL BOX DIMENSIONS**

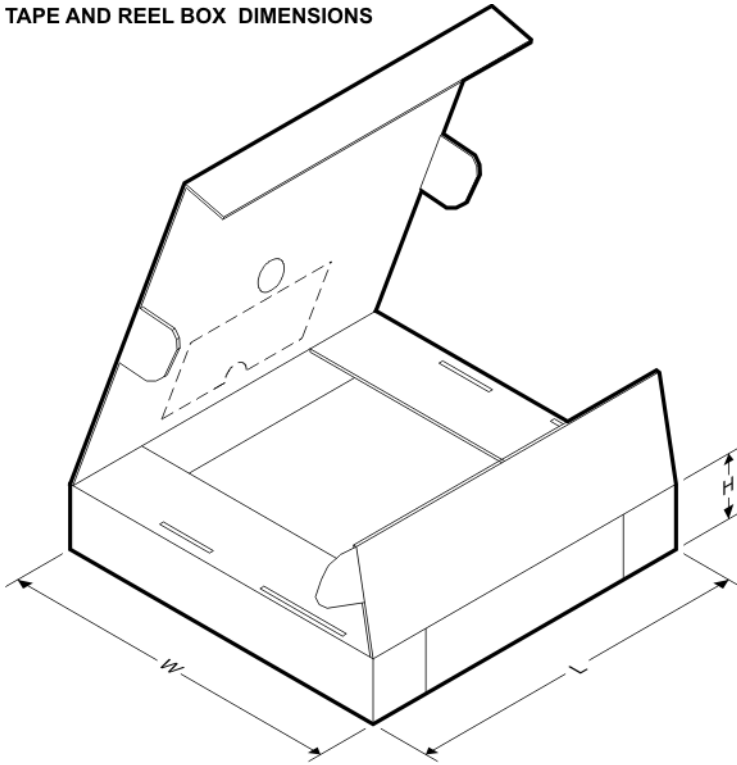

\*All dimensions are nominal

| Device          | Package Type | Package Drawing | Pins | SPQ  | Length (mm) | Width (mm) | Height (mm) |
|-----------------|--------------|-----------------|------|------|-------------|------------|-------------|
| TPIC7218QPFPRQ1 | HTQFP        | PFP             | 80   | 1000 | 367.0       | 367.0      | 45.0        |

# MECHANICAL DATA

PFP (S-PQFP-G80)

PowerPAD™ PLASTIC QUAD FLATPACK

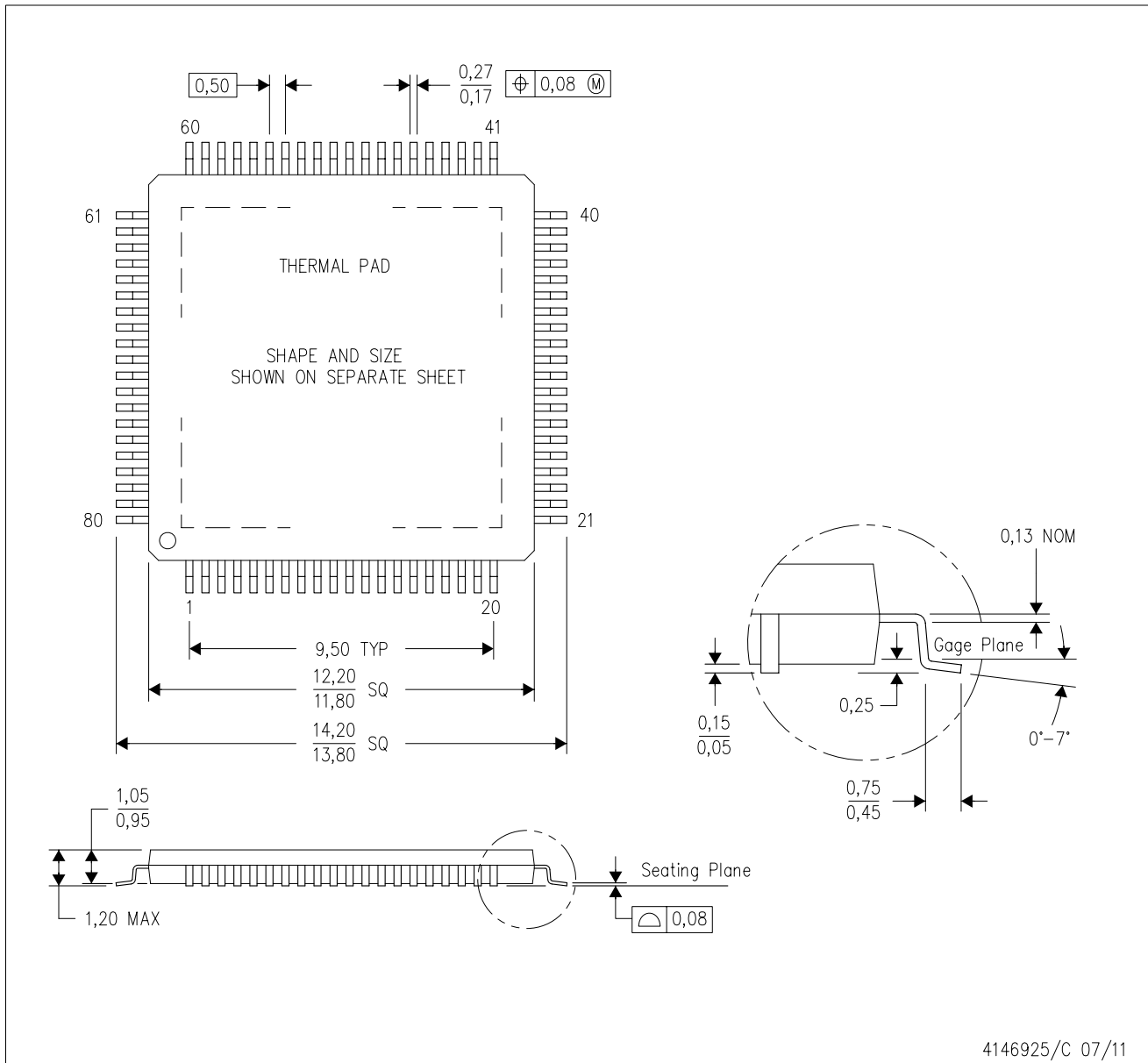

- NOTES:
- A. All linear dimensions are in millimeters.
  - B. This drawing is subject to change without notice.
  - C. Body dimensions do not include mold flash or protrusion
  - D. This package is designed to be soldered to a thermal pad on the board. Refer to Technical Brief, PowerPad Thermally Enhanced Package, Texas Instruments Literature No. SLMA002 for information regarding recommended board layout. This document is available at [www.ti.com](http://www.ti.com) <<http://www.ti.com>>.
  - E. See the additional figure in the Product Data Sheet for details regarding the exposed thermal pad features and dimensions.
  - F. Falls within JEDEC MS-026

PowerPAD is a trademark of Texas Instruments.

## THERMAL PAD MECHANICAL DATA

PFP (S-PQFP-G80)

PowerPAD™ PLASTIC QUAD FLATPACK

### THERMAL INFORMATION

This PowerPAD™ package incorporates an exposed thermal pad that is designed to be attached to a printed circuit board (PCB). The thermal pad must be soldered directly to the PCB. After soldering, the PCB can be used as a heatsink. In addition, through the use of thermal vias, the thermal pad can be attached directly to the appropriate copper plane shown in the electrical schematic for the device, or alternatively, can be attached to a special heatsink structure designed into the PCB. This design optimizes the heat transfer from the integrated circuit (IC).

For additional information on the PowerPAD package and how to take advantage of its heat dissipating abilities, refer to Technical Brief, PowerPAD Thermally Enhanced Package, Texas Instruments Literature No. SLMA002 and Application Brief, PowerPAD Made Easy, Texas Instruments Literature No. SLMA004. Both documents are available at [www.ti.com](http://www.ti.com).

The exposed thermal pad dimensions for this package are shown in the following illustration.

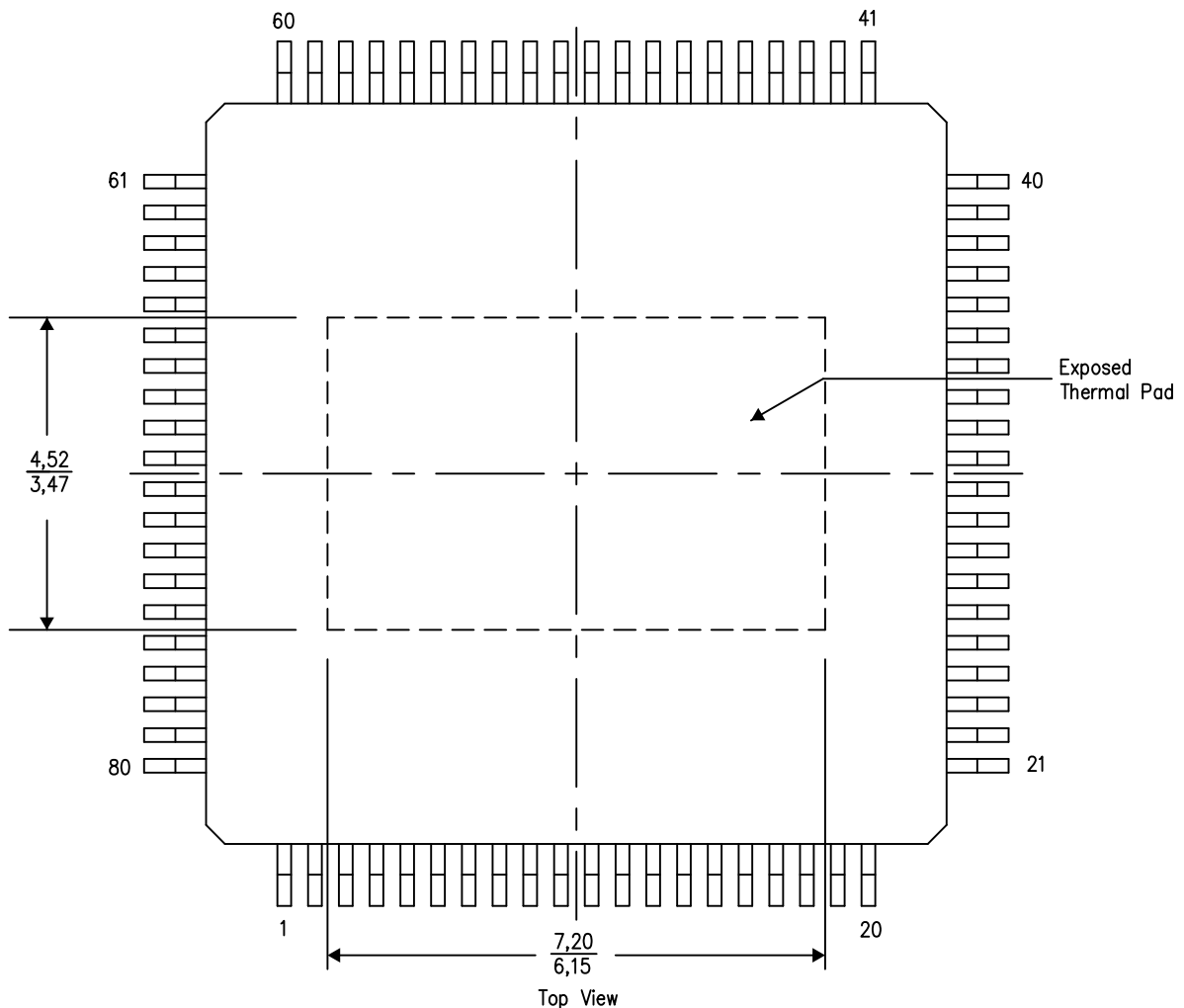

4206327-8/P 05/14

NOTE: A. All linear dimensions are in millimeters

PowerPAD is a trademark of Texas Instruments

PFP (S-PQFP-G80)

PowerPAD™ PLASTIC QUAD FLATPACK

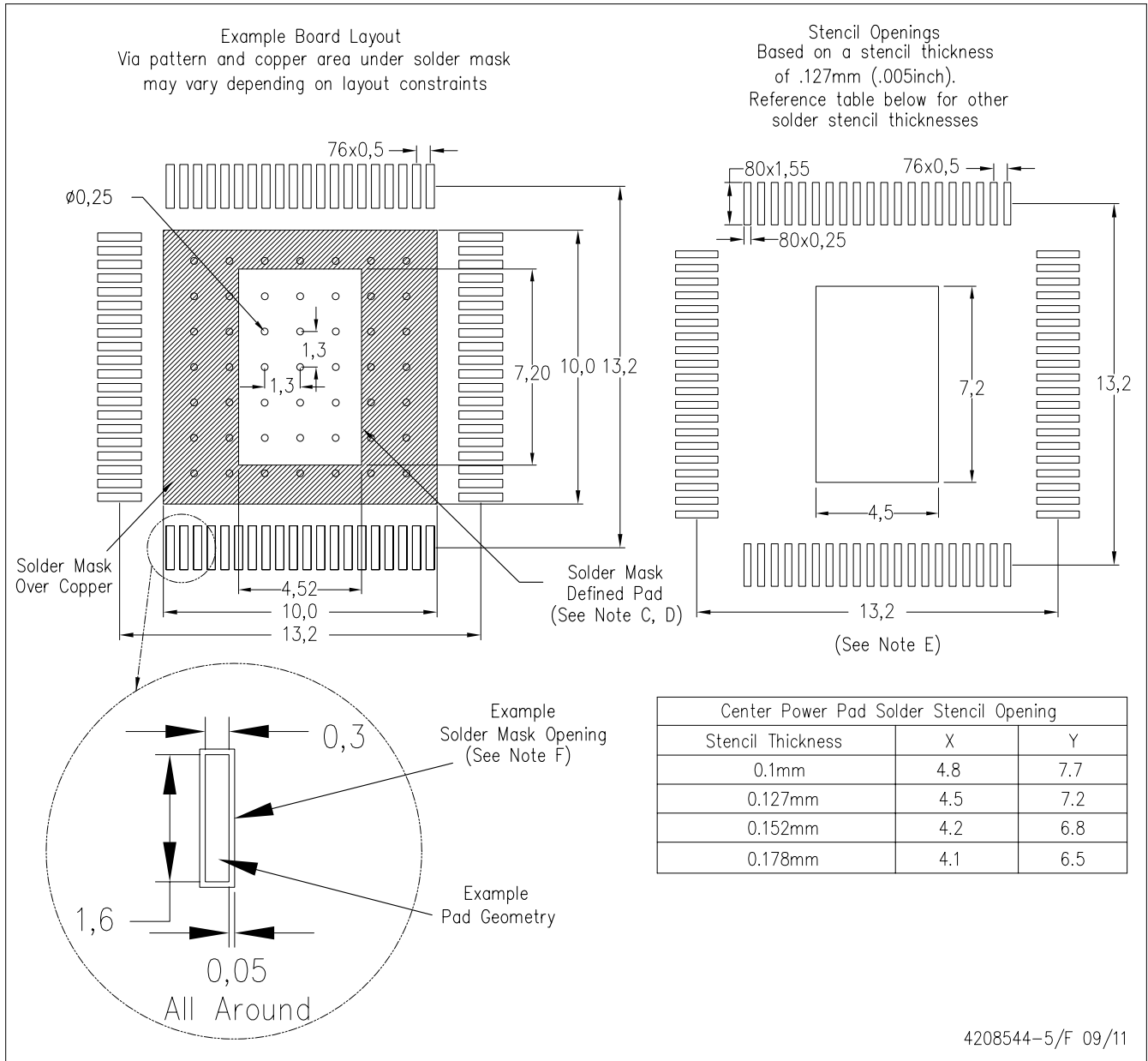

- NOTES:
- A. All linear dimensions are in millimeters.
  - B. This drawing is subject to change without notice.
  - C. Customers should place a note on the circuit board fabrication drawing not to alter the center solder mask defined pad.
  - D. This package is designed to be soldered to a thermal pad on the board. Refer to Technical Brief, PowerPAD Thermally Enhanced Package, Texas Instruments Literature No. SLMA002, SLMA004, and also the Product Data Sheets for specific thermal information, via requirements, and recommended board layout. These documents are available at [www.ti.com](http://www.ti.com) <<http://www.ti.com>>. Publication IPC-SM-7351 is recommended for alternate designs.
  - E. Laser cutting apertures with trapezoidal walls and also rounding corners will offer better paste release. Customers should contact their board assembly site for stencil design recommendations. Example stencil design based on a 50% volumetric metal load solder paste. Refer to IPC-7525 for other stencil recommendations.
  - F. Customers should contact their board fabrication site for solder mask tolerances between and around signal pads.
- PowerPAD is a trademark of Texas Instruments.

## IMPORTANT NOTICE

Texas Instruments Incorporated and its subsidiaries (TI) reserve the right to make corrections, enhancements, improvements and other changes to its semiconductor products and services per JESD46, latest issue, and to discontinue any product or service per JESD48, latest issue. Buyers should obtain the latest relevant information before placing orders and should verify that such information is current and complete. All semiconductor products (also referred to herein as "components") are sold subject to TI's terms and conditions of sale supplied at the time of order acknowledgment.

TI warrants performance of its components to the specifications applicable at the time of sale, in accordance with the warranty in TI's terms and conditions of sale of semiconductor products. Testing and other quality control techniques are used to the extent TI deems necessary to support this warranty. Except where mandated by applicable law, testing of all parameters of each component is not necessarily performed.

TI assumes no liability for applications assistance or the design of Buyers' products. Buyers are responsible for their products and applications using TI components. To minimize the risks associated with Buyers' products and applications, Buyers should provide adequate design and operating safeguards.

TI does not warrant or represent that any license, either express or implied, is granted under any patent right, copyright, mask work right, or other intellectual property right relating to any combination, machine, or process in which TI components or services are used. Information published by TI regarding third-party products or services does not constitute a license to use such products or services or a warranty or endorsement thereof. Use of such information may require a license from a third party under the patents or other intellectual property of the third party, or a license from TI under the patents or other intellectual property of TI.

Reproduction of significant portions of TI information in TI data books or data sheets is permissible only if reproduction is without alteration and is accompanied by all associated warranties, conditions, limitations, and notices. TI is not responsible or liable for such altered documentation. Information of third parties may be subject to additional restrictions.

Resale of TI components or services with statements different from or beyond the parameters stated by TI for that component or service voids all express and any implied warranties for the associated TI component or service and is an unfair and deceptive business practice. TI is not responsible or liable for any such statements.

Buyer acknowledges and agrees that it is solely responsible for compliance with all legal, regulatory and safety-related requirements concerning its products, and any use of TI components in its applications, notwithstanding any applications-related information or support that may be provided by TI. Buyer represents and agrees that it has all the necessary expertise to create and implement safeguards which anticipate dangerous consequences of failures, monitor failures and their consequences, lessen the likelihood of failures that might cause harm and take appropriate remedial actions. Buyer will fully indemnify TI and its representatives against any damages arising out of the use of any TI components in safety-critical applications.

In some cases, TI components may be promoted specifically to facilitate safety-related applications. With such components, TI's goal is to help enable customers to design and create their own end-product solutions that meet applicable functional safety standards and requirements. Nonetheless, such components are subject to these terms.

No TI components are authorized for use in FDA Class III (or similar life-critical medical equipment) unless authorized officers of the parties have executed a special agreement specifically governing such use.

Only those TI components which TI has specifically designated as military grade or "enhanced plastic" are designed and intended for use in military/aerospace applications or environments. Buyer acknowledges and agrees that any military or aerospace use of TI components which have **not** been so designated is solely at the Buyer's risk, and that Buyer is solely responsible for compliance with all legal and regulatory requirements in connection with such use.

TI has specifically designated certain components as meeting ISO/TS16949 requirements, mainly for automotive use. In any case of use of non-designated products, TI will not be responsible for any failure to meet ISO/TS16949.

### Products

|                              |  |
|------------------------------|--|
| Audio                        | <a href="http://www.ti.com/audio">www.ti.com/audio</a>                               |
| Amplifiers                   | <a href="http://amplifier.ti.com">amplifier.ti.com</a>                               |
| Data Converters              | <a href="http://dataconverter.ti.com">dataconverter.ti.com</a>                       |
| DLP® Products                | <a href="http://www.dlp.com">www.dlp.com</a>   |
| DSP                          | <a href="http://dsp.ti.com">dsp.ti.com</a>   |
| Clocks and Timers            | <a href="http://www.ti.com/clocks">www.ti.com/clocks</a>                             |
| Interface                    | <a href="http://interface.ti.com">interface.ti.com</a>                               |
| Logic                        | <a href="http://logic.ti.com">logic.ti.com</a>                                       |
| Power Mgmt                   | <a href="http://power.ti.com">power.ti.com</a>                                       |
| Microcontrollers             | <a href="http://microcontroller.ti.com">microcontroller.ti.com</a>                   |
| RFID                         | <a href="http://www.ti-rfid.com">www.ti-rfid.com</a>                                 |
| OMAP Applications Processors | <a href="http://www.ti.com/omap">www.ti.com/omap</a>                                 |
| Wireless Connectivity        | <a href="http://www.ti.com/wirelessconnectivity">www.ti.com/wirelessconnectivity</a> |

### Applications

|                               |  |
|-------------------------------|--|
| Automotive and Transportation | <a href="http://www.ti.com/automotive">www.ti.com/automotive</a>                         |
| Communications and Telecom    | <a href="http://www.ti.com/communications">www.ti.com/communications</a>                 |
| Computers and Peripherals     | <a href="http://www.ti.com/computers">www.ti.com/computers</a>                           |
| Consumer Electronics          | <a href="http://www.ti.com/consumer-apps">www.ti.com/consumer-apps</a>                   |
| Energy and Lighting           | <a href="http://www.ti.com/energy">www.ti.com/energy</a>                                 |
| Industrial                    | <a href="http://www.ti.com/industrial">www.ti.com/industrial</a>                         |
| Medical                       | <a href="http://www.ti.com/medical">www.ti.com/medical</a>                               |
| Security                      | <a href="http://www.ti.com/security">www.ti.com/security</a>                             |
| Space, Avionics and Defense   | <a href="http://www.ti.com/space-avionics-defense">www.ti.com/space-avionics-defense</a> |
| Video and Imaging             | <a href="http://www.ti.com/video">www.ti.com/video</a>                                   |

### TI E2E Community

[e2e.ti.com](http://e2e.ti.com)