

## TPL5000 Nano-Power Programmable Timer with Watchdog Functionality

### 1 Features

- Supply Voltage from 1.8 V to 5.0 V
- Current Consumption 30 nA (typical, at 2.5 V)
- Watchdog Functionality
- Reset Functionality
- Selectable Timer Intervals 1 to 64 s

### 2 Applications

- Battery-Powered Systems
- Energy-Harvesting Systems
- Remote Data-Logger
- Sensor Node
- Building Automation
- Consumer Electronic
- Low-Power Wireless
- Safety and Security Platforms

### 3 Description

The TPL5000 is a long-term timer IC optimized for low-power applications. The TPL5000 can replace a micro controller's ( $\mu\text{C}$ ) internal timer, allowing the  $\mu\text{C}$  to stay in low-power sleep mode instead of running a timer, providing a total power consumption reduction of 60 to 80%. The TPL5000 is designed for use in interrupt-driven applications and provides selectable timing from 1 second to 64 seconds. Some standards (such as EN50271) require implementation of a watchdog function for safety. The TPL5000 realizes this watchdog function without consuming additional power. The TPL5000 can also monitor a battery management IC via a power-good digital input and reset the microcontroller, if necessary. The device is packaged in a 10-pin VSSOP package.

#### Device Information<sup>(1)</sup>

PART NUMBER	PACKAGE	BODY SIZE (NOM)
TPL5000	VSSOP (10)	3.00 mm x 3.00 mm

(1) For all available packages, see the orderable addendum at the end of the datasheet.

### 4 Simplified Application Schematic

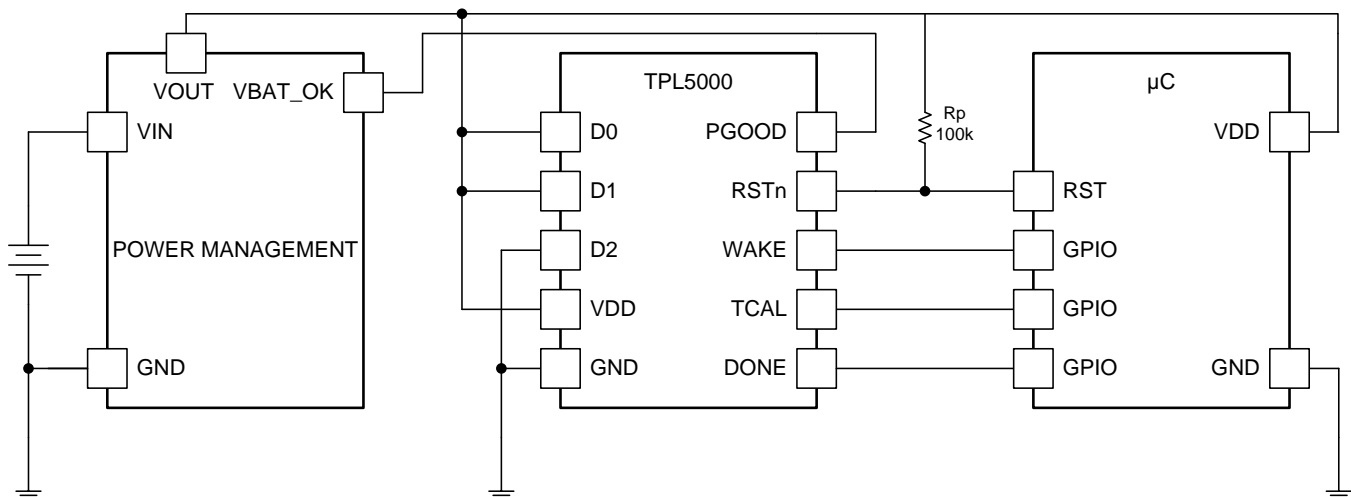

## Table of Contents

<b>1 Features</b> .....	<b>1</b>	8.2 Functional Block Diagram .....	<b>8</b>
<b>2 Applications</b> .....	<b>1</b>	8.3 Feature Description.....	<b>8</b>
<b>3 Description</b> .....	<b>1</b>	8.4 Device Functional Modes.....	<b>11</b>
<b>4 Simplified Application Schematic</b> .....	<b>1</b>	<b>9 Application and Implementation</b> .....	<b>12</b>
<b>5 Revision History</b> .....	<b>2</b>	9.1 Application Information.....	<b>12</b>
<b>6 Pin Configuration and Functions</b> .....	<b>3</b>	9.2 Typical Application .....	<b>12</b>
<b>7 Specifications</b> .....	<b>4</b>	<b>10 Power Supply Recommendations</b> .....	<b>14</b>
7.1 Absolute Maximum Ratings .....	<b>4</b>	<b>11 Layout</b> .....	<b>14</b>
7.2 ESD Ratings.....	<b>4</b>	11.1 Layout Guidelines .....	<b>14</b>
7.3 Recommended Operating Ratings .....	<b>4</b>	11.2 Layout Example .....	<b>14</b>
7.4 Thermal Information .....	<b>4</b>	<b>12 Device and Documentation Support</b> .....	<b>15</b>
7.5 Electrical Characteristics.....	<b>5</b>	12.1 Trademarks .....	<b>15</b>
7.6 Timing Requirements .....	<b>6</b>	12.2 Electrostatic Discharge Caution.....	<b>15</b>
7.7 Typical Characteristics.....	<b>7</b>	12.3 Glossary .....	<b>15</b>
<b>8 Detailed Description</b> .....	<b>8</b>	<b>13 Mechanical, Packaging, and Orderable Information</b> .....	<b>15</b>
8.1 Overview .....	<b>8</b>		

## 5 Revision History

### Changes from Revision A (July 2013) to Revision B

Page

<ul style="list-style-type: none"> <li>Added <i>ESD Ratings table, Feature Description section, Device Functional Modes, Application and Implementation section, Power Supply Recommendations section, Layout section, Device and Documentation Support section, and Mechanical, Packaging, and Orderable Information section</i> .....</li> </ul>	<b>3</b>
--	----------

## 6 Pin Configuration and Functions

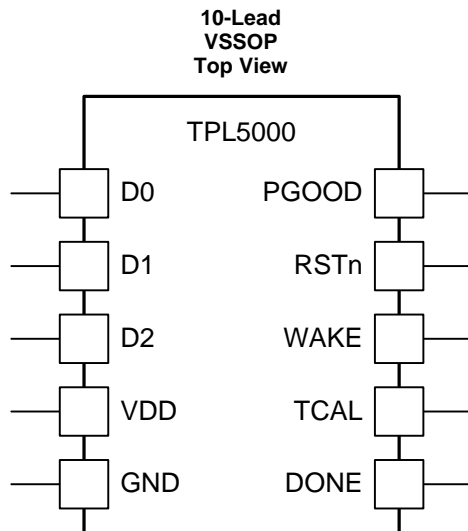

### Pin Functions

PIN		DESCRIPTION	APPLICATION INFORMATION
NAME	NO.		
D0	1	Logic Input to set period delay ( $t_{DP}$ )	Connect to either GND (low logic value) or VDD (high logic value)
D1	2	Logic Input to set period delay ( $t_{DP}$ )	Connect to either GND (low logic value) or VDD (high logic value)
D2	3	Logic Input to set period delay ( $t_{DP}$ )	Connect to either GND (low logic value) or VDD (high logic value)
VDD	4	Supply voltage	
GND	5	Ground	
DONE	6	Logic Input for watchdog functionality	
TCAL	7	Short duration pulse output for estimation of TPL5000 timer delay.	
WAKE	8	Timer output signal generated every $t_{DP}$ period.	
RSTn	9	Reset Output (open drain output)	
PGOOD	10	Digital power good input	

## 7 Specifications

### 7.1 Absolute Maximum Ratings

 over operating free-air temperature (unless otherwise noted) <sup>(1)</sup>

	MIN	MAX	UNIT
Supply Voltage	-0.3	6.0	V
Input Voltage <sup>(2)</sup>	-0.3	VDD + 0.3	V
Voltage between any two pins		VDD + 0.3	V
Input Current on any pin	-5	5	mA
Operating Temperature, T <sub>A</sub>	-40	105	
Junction Temperature, T <sub>J</sub> <sup>(3)</sup>		150	°C
Storage Temperature, T <sub>stg</sub>	-65	150	°C

(1) Stresses beyond those listed under *Absolute Maximum Ratings* may cause permanent damage to the device. These are stress ratings only, which do not imply functional operation of the device at these or any other conditions beyond those indicated under *Recommended Operating Conditions*. Exposure to absolute-maximum-rated conditions for extended periods may affect device reliability.

(2) When the input voltage (V<sub>IN</sub>) at any pin exceeds the power supply (V<sub>DD</sub>), the current on that pin must not exceed 5 mA and must not exceed 6.0 V.

(3) The maximum power dissipation is a function of T<sub>J(MAX)</sub>, R<sub>θJA</sub>, and the ambient temperature, T<sub>A</sub>. The maximum allowable power dissipation at any ambient temperature is P<sub>DMAX</sub> = (T<sub>J(MAX)</sub> - T<sub>A</sub>) / θ<sub>JA</sub>. All numbers apply for packages soldered directly onto a PCB.

### 7.2 ESD Ratings

		VALUE	UNIT
V <sub>(ESD)</sub> Electrostatic discharge	Human-body model (HBM), per ANSI/ESDA/JEDEC JS-001 <sup>(1)</sup>	±2000	V
	Charged-device model (CDM), per JEDEC specification JESD22-C101 <sup>(2)</sup>	±500	

(1) JEDEC document JEP155 states that 500-V HBM allows safe manufacturing with a standard ESD control process.

(2) JEDEC document JEP157 states that 250-V CDM allows safe manufacturing with a standard ESD control process.

### 7.3 Recommended Operating Ratings

	MIN	MAX	UNIT
Supply Voltage (VDD-GND)	1.8	5.0	V
Temperature Range	-40	105	°C

### 7.4 Thermal Information

THERMAL METRIC <sup>(1)</sup>	TPL5000	UNIT
	VSSOP	
	10 PINS	
R <sub>θJA</sub> Junction-to-ambient thermal resistance	196.8	°C/W

(1) For more information about traditional and new thermal metrics, see the *IC Package Thermal Metrics* application report, [SPRA953](#).

## 7.5 Electrical Characteristics<sup>(1)</sup>

Specifications are for  $T_A = T_J = 25^\circ\text{C}$ ,  $V_{DD-GND} = 2.5\text{ V}$ , unless otherwise stated.

PARAMETER		TEST CONDITIONS	MIN <sup>(2)</sup>	TYP <sup>(3)</sup>	MAX <sup>(2)</sup>	UNIT
<b>POWER SUPPLY</b>						
IVDD	Supply current <sup>(4)</sup>	PGOOD = VDD		30	50	nA
		PGOOD = GND		12		nA
<b>TIMER</b>						
t <sub>DP</sub>	Timer Delay Period			1, 2, 4, 8, 10, 16, 32, 64		s
	Timer Delay drift over life time <sup>(5)</sup>			0.06%		
	Timer Delay drift over temperature			400		ppm/°C
t <sub>CAL</sub>	Calibration pulse width		14.063	15.625	17.188	ms
	t <sub>DP</sub> to t <sub>CAL</sub> matching error <sup>(6)</sup>	VDD ≤ 3.0 V			0.1	
t <sub>DONE</sub>	DONE Pulse width <sup>(6)</sup>		100			ns
t <sub>RSTn</sub>	RSTn Pulse width			15.625		ms
t <sub>WAKE</sub>	WAKE Pulse width			31.25		ms
<b>DIGITAL LOGIC LEVELS</b>						
VIH	Logic High Threshold	PGOOD, DONE	0.7xVDD			V
VIL	Logic Low Threshold	PGOOD, DONE			0.3xVDD	V
VOH	Logic output High Level	WAKE, TCAL Iout = 100 $\mu$ A	VDD-0.3			V
		WAKE, TCAL Iout = 1 mA	VDD-0.7			V
VOL	Logic output Low Level	WAKE, TCAL Iout = -100 $\mu$ A			0.3	V
		WAKE, TCAL Iout = -1 mA			0.7	V
VOL <sub>RSTn</sub>	RSTn Logic output Low Level	IOL = -1 mA			0.3	V
IOH <sub>RSTn</sub>	RSTn High Level output current	VOH <sub>RSTn</sub> = VDD		1		nA

- (1) Electrical Characteristics Table values apply only for factory testing conditions at the temperature indicated. Factory testing conditions result in very limited self-heating of the device such that  $T_J = T_A$ .
- (2) Limits are specified by testing, design, or statistical analysis at 25°C. Limits over the operating temperature range are specified through correlations using statistical quality control (SQC) method.
- (3) Typical values represent the most likely parametric norm as determined at the time of characterization. Actual typical values may vary over time and will also depend on the application and configuration. The typical values are not tested and are not specified on shipped production material.
- (4) The supply current does not take in account load and pull-up resistor current. Input pins are at GND or VDD.
- (5) Operational life time test procedure equivalent to 10 years.
- (6) Ensured by design.

## 7.6 Timing Requirements

			MIN	TYP	MAX	UNIT
$t_{rTCAL}$	Rise Time TCAL	Capacitive load 15 pF		50		ns
$t_{fTCAL}$	Fall Time TCAL	Capacitive load 15 pF		50		ns
$t_{rRSTn}$	Rise Time RSTn	Capacitive load 15 pF, Rpull-up 100Kohm		4		ns
$t_{fRSTn}$	Fall Time RSTn	Capacitive load 15 pF, Rpull-up 100Kohm		50		ns
$t_{rWAKE}$	Rise Time WAKE	Capacitive load 15 pF		50		ns
$t_{fWAKE}$	Fall Time WAKE	Capacitive load 15 pF		50		ns
$t_{D_{DONE}}$	DONE to RSTn or WAKE delay	Min delay		100		ns
		Max delay		$t_{DP} - 5 * t_{CAL}$		ms
$t_{D_{TCAL}}$	TCAL to RSTn or WAKE delay			$t_{CAL} / 2$		ms

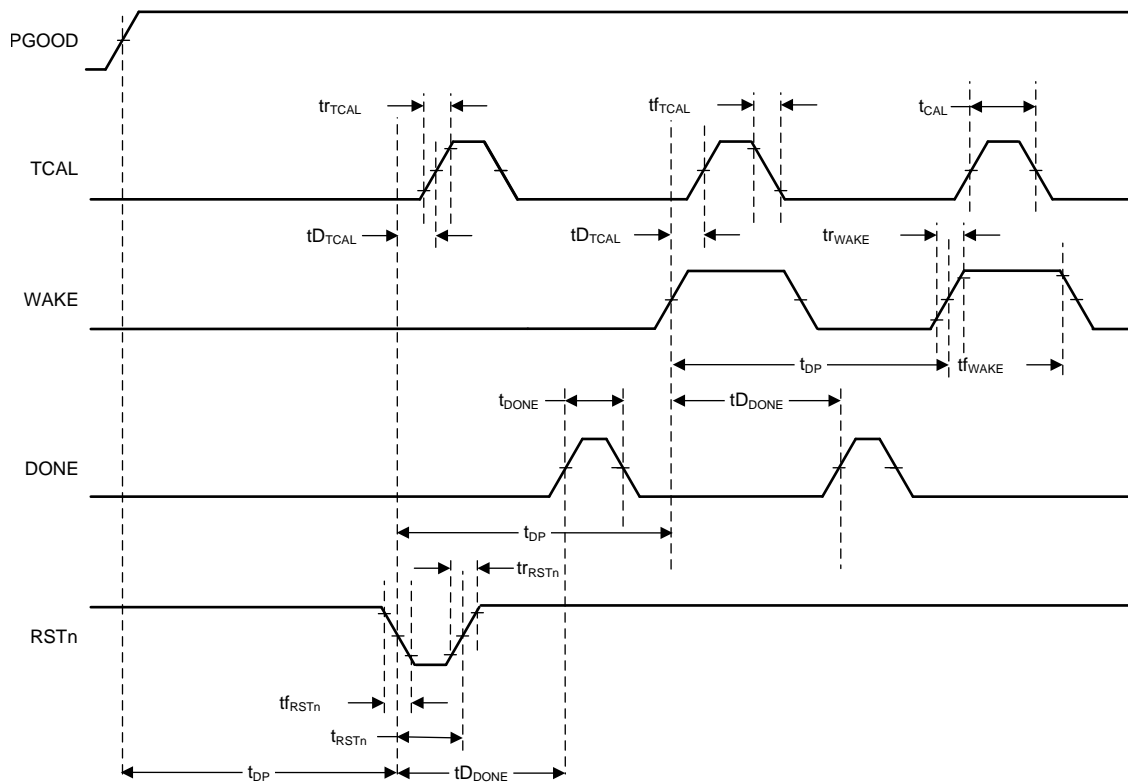

**Figure 1. Timing Diagram**

## 7.7 Typical Characteristics

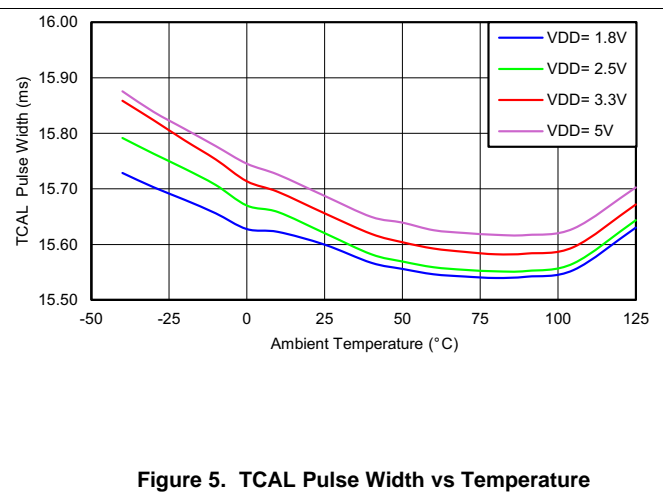
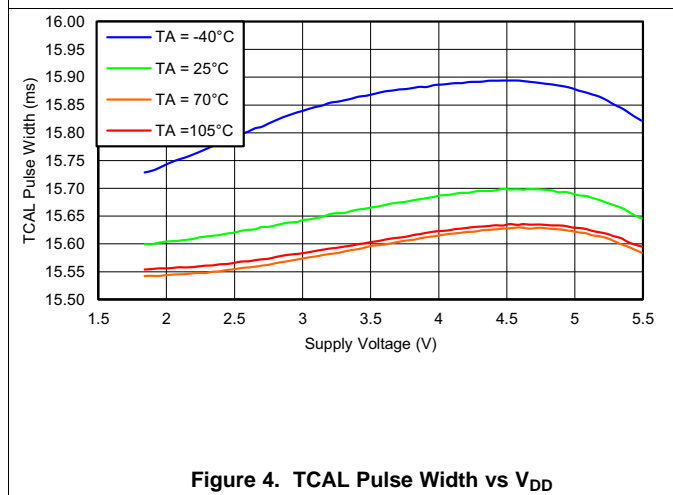
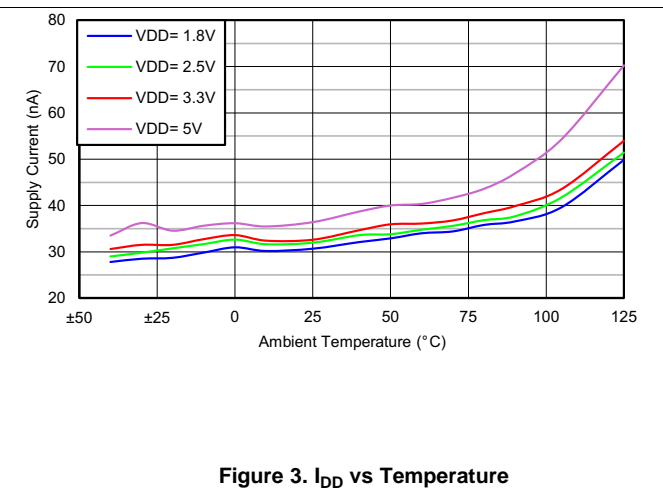
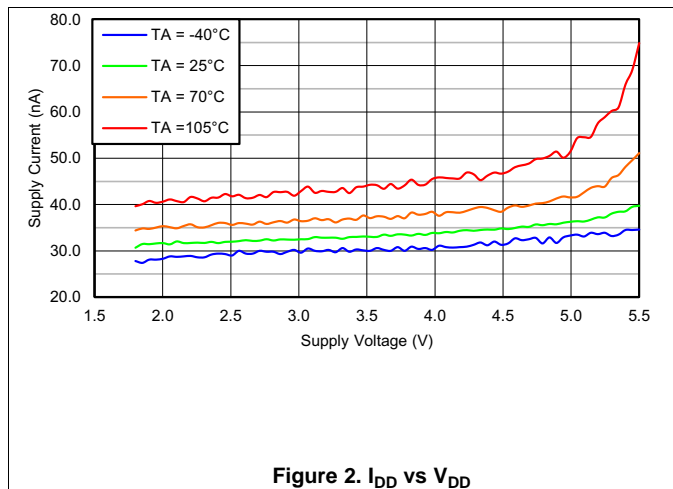

## 8 Detailed Description

### 8.1 Overview

The TPL5000 is a long-term timer with a watchdog feature for low-power applications. The TPL5000 is designed for use in interrupt-driven applications and provides selectable timing from 1 s to 64 s. An additional supervisor feature is achieved through interfacing the TPL5000 to a power-management IC.

### 8.2 Functional Block Diagram

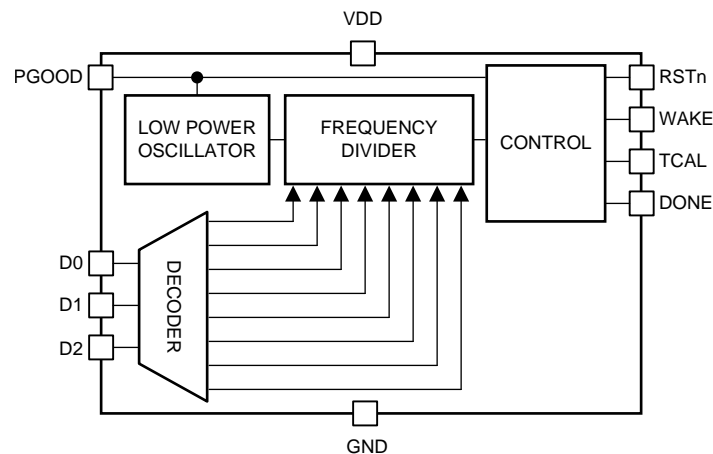

### 8.3 Feature Description

#### 8.3.1 Supervisor Feature

A critical event that can corrupt the memory of a microcontroller is a voltage supply drop (supply lower than minimum operating range), and a reset of the microcontroller is mandatory if this occurs. Since the TPL5000 is the right choice in systems which stay most of the time in deep sleep, due to its ultra-low power consumption, it is fundamental that it takes into account the voltage drop events.

The TPL5000 implements a supervisory functionality when working with some power-management ICs which indicate the status of the supply voltage with a power-good or battery-good output. The supervisory functionality is enabled by simply connecting the Battery management power-good output to the TPL5000 PGOOD pin. If this feature is not used connect the PGOOD pin to VDD.

In case the power management IC detects a voltage drop, lowering the PGOOD line, while the microcontroller is in deep sleep mode (in which internal supervisors are usually off), the TPL5000 internally latches that event, and when the PGOOD returns to high, it sends out a RESET signal to the microcontroller at the end of the elapsed delay period.

**Figure 6** shows the supervisor feature of the TPL5000. The sequence F, G is a standard sequence where the microcontroller is in deep sleep and a voltage supply drop occurs (which is highlighted by the PGOOD high to low transition). When PGOOD is high again, a reset pulse at the end of the delay period is sent to the microcontroller (arrow F), then the microcontroller executes its routine (memory has been reloaded upon reset) and sends the "DONE" signal.

## Feature Description (continued)

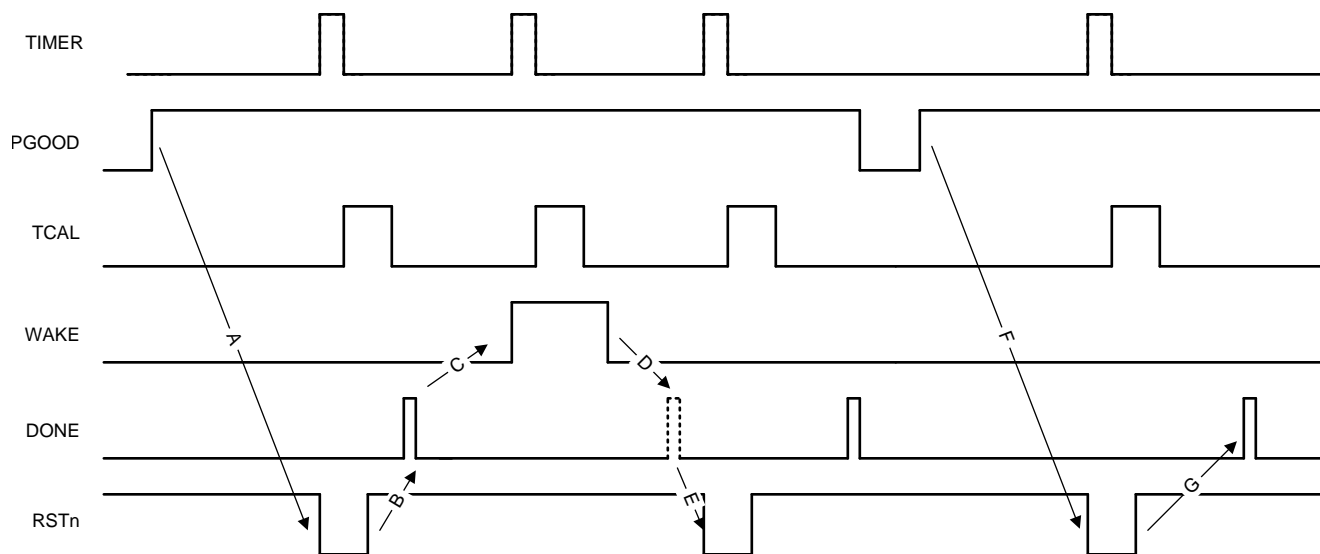

Figure 6. Watchdog and Supervisor Feature

### 8.3.1.1 Calibration Pulse

The TPL5000 is based on a ultra-low power oscillator which has a relatively low frequency and low accuracy; however, it shows very good cycle-to-cycle repeatability and very low temperature drift. In most of the applications, the accuracy of the oscillator is enough, but if a more accurate measure of the delay period is required, it is possible to measure the base period of the internal oscillator. A single pulse, which has the same duration as the base period of the internal oscillator, is present at the TCAL pin of the TPL5000. This pulse starts after a half period of the internal oscillator from either the falling edge of the RESET pulse, or the rising edge of the WAKE pulse.

A microcontroller connected to the TPL5000 can routinely measure the width of the TCAL pulse using a counter and an external crystal. Once the base period of the TPL5000 is measured, the actual time delay is calculated by multiplying the measured period by a factor, N (see Table 1), dependent on the nominal selected time delay.

The resolution and the accuracy of the measurement depend on the external crystal. Since the frequency of the internal oscillator of the TPL5000 is very stable, the measurement of the calibration pulse is suggested only when a high gradient of ambient temperature is observed. The measurement of the TCAL pulse is useful in battery-powered applications that implement a precise battery life counter in the microcontroller.

### 8.3.1.2 Overview of the Timing Signals: WAKE, RSTn, TCAL and DONE

Figure 7 shows the timing of WAKE, RSTn, and TCAL with respect to DONE. The frame, A, shows a typical sequence after the PGOOD, low to high, transition. As soon as PGOOD is high, the internal oscillator is powered ON. At the end of the delay period ( $t_{DP}$ ), a reset signal (RSTn), followed by a calibration pulse, TCAL, is sent out. The calibration pulse starts after a half period of the internal oscillator from the falling edge of the reset, and lasts one internal oscillator period.

The frame, B, shows a standard sequence. A "DONE" signal has been received in the previous delay period, so at the end of the next delay period, a "WAKE", followed by a calibration pulse, is sent out. The WAKE signal stays high for 2 internal oscillator periods. The calibration pulse starts after a half period of the internal oscillator from the rising edge of the WAKE signal, and lasts one internal oscillator period. In this frame, the TPL5000 receives a "DONE" signal before the end of the delay period.

The frame, C, still shows a standard sequence, but in this case, the TPL5000 receives the DONE signal when both WAKE and TCAL pulses are still high. As soon as the TPL5000 recognizes the DONE resets the counter and puts WAKE and TCAL in the default condition (both signal low).

## Feature Description (continued)

The frame, D, shows a typical PGOOD, high to low transition. As soon as PGOOD is low, the internal oscillator is powered OFF and the digital output pins, TCAL, RSTn, and WAKE, are asynchronously reset by the falling edge of the PGOOD signal, such that TCAL and WAKE reset at low logical values, while RSTn resets at a high logical value.

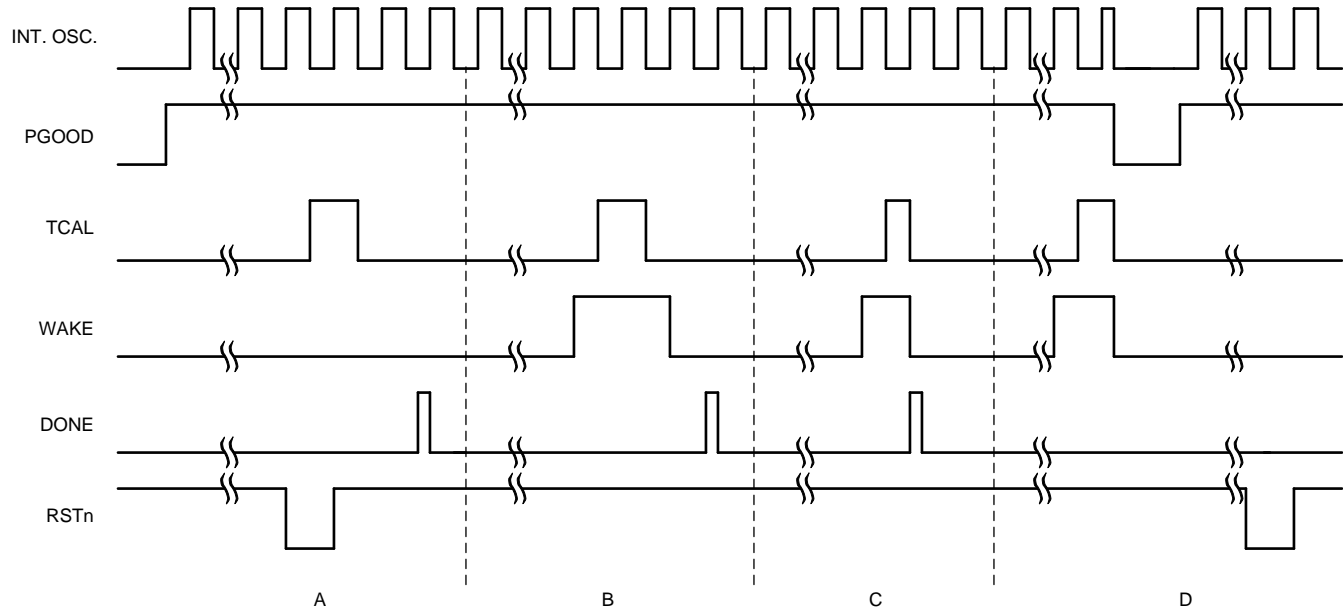

**Figure 7. Timing PGOOD, WAKE, RSTn, TCAL**

### 8.3.1.3 Watchdog Feature

Most of the microcontroller-based systems need to be self-reliant; if the software hangs for any reason, the microcontroller must be reset. The TPL5000 can provide this functionality by connecting a microcontroller programmable output pin to the DONE input pin. If the DONE line does not toggle within the selected delay period, then the microcontroller is not operating properly and must be reset.

The TPL5000 recognizes a valid DONE signal as a low to high transition; if two DONE signals are received within the delay period the second signal is ignored.

In the TPL5000, the watchdog window and the delay period are equivalent. A valid "DONE" signal resets the watchdog counter only, and not the delay time counter. A PGOOD low to high transition clears both the watchdog and delay time counters.

Figure 6 shows the watchdog feature of the TPL5000. The sequence A, B, C is a standard sequence with the microcontroller working properly. In this normal sequence, the microcontroller sends a valid "DONE" (arrow B) before the end of the delay period. The sequence C, D, E is an anomalous sequence in which the microcontroller is not in a valid state, and it does not send the DONE signal (dashed pulse) before the end of the delay period. The TPL5000 determines the microcontroller is hung and sends a RESET signal (arrow E) when the period delay has elapsed.

### 8.3.1.4 Different Utilizations of the TPL5000

When either the watchdog or the supervisor feature of the TPL5000 are not required, it is possible to disable them reducing the interconnections between the TPL5000 and the microcontroller.

Connecting the DONE pin either to GND or to TCAL pin disables the watchdog feature. If connected to GND, the TPL5000 only sends a reset pulse when the time delay elapses. If DONE is connected to TCAL, the TPL5000 sends out just one RESET pulse after a PGOOD low to high transition, when the time delay elapses and then WAKE pulses when the successive time delay elapses.

Connecting the PGOOD pin to the supply pin of the TPL5000 disables the supervisor feature.

## Feature Description (continued)

### 8.3.2 Configuration and Interface

The time interval between 2 adjacent WAKE pulses (or 2 adjacent RSTn pulses or RSTn and WAKE pulses) is selectable through 3 digital input pins (D0, D1, D2). These pins can be strapped to either VDD (1) or GND (0). Eight possible time delays can be selected, as shown in [Table 1](#).

**Table 1. Timer Delay Period**

D2	D1	D0	Time (s)	Factor N
0	0	0	1	2 <sup>6</sup>
0	0	1	2	2 <sup>7</sup>
0	1	0	4	2 <sup>8</sup>
0	1	1	8	2 <sup>9</sup>
1	0	0	10	10*2 <sup>6</sup>
1	0	1	16	2 <sup>10</sup>
1	1	0	32	2 <sup>11</sup>
1	1	1	64	2 <sup>12</sup>

### 8.4 Device Functional Modes

The TPL5000 mode of operations are selected through the PGOOD pin. There are two factors to consider when the PGOOD pin is at a high-logic level or low-logic level. When the PGOOD pin is at a high-logic level, the TPL5000 works as a timer and conversely at a low-logic level the TPL5000 does not work as a timer. For best use of TPL5000 waiting for high-logic is necessary.

## 9 Application and Implementation

### NOTE

Information in the following applications sections is not part of the TI component specification, and TI does not warrant its accuracy or completeness. TI's customers are responsible for determining suitability of components for their purposes. Customers should validate and test their design implementation to confirm system functionality.

### 9.1 Application Information

In battery powered applications the design of the system is driven by low current consumption. The TPL5000 is suitable in the applications where there is the needs to monitor environment conditions at fixed timer interval. Often in these applications the micro is kept on to enable the watchdog and to count the elapsed time. Some time due to the high frequency clock of the micro controllers special structure needs to be configured to count for long time (several seconds). The TPL5000 can do the same job burning only tens of nA.

### 9.2 Typical Application

The TPL5000 can be used in conjunction with environment sensors to build a low-power environment data-logger, such as an air quality data-logger. In this application due to the monitored phenomena the micro-controller and the front end of the sensor spend most of the time in idle state, waiting for the next working interval, usually few hundred of ms. The application is based on a micro-controller which represents the core of the data-logger, a front end for gas sensor, such as the LMP91000.

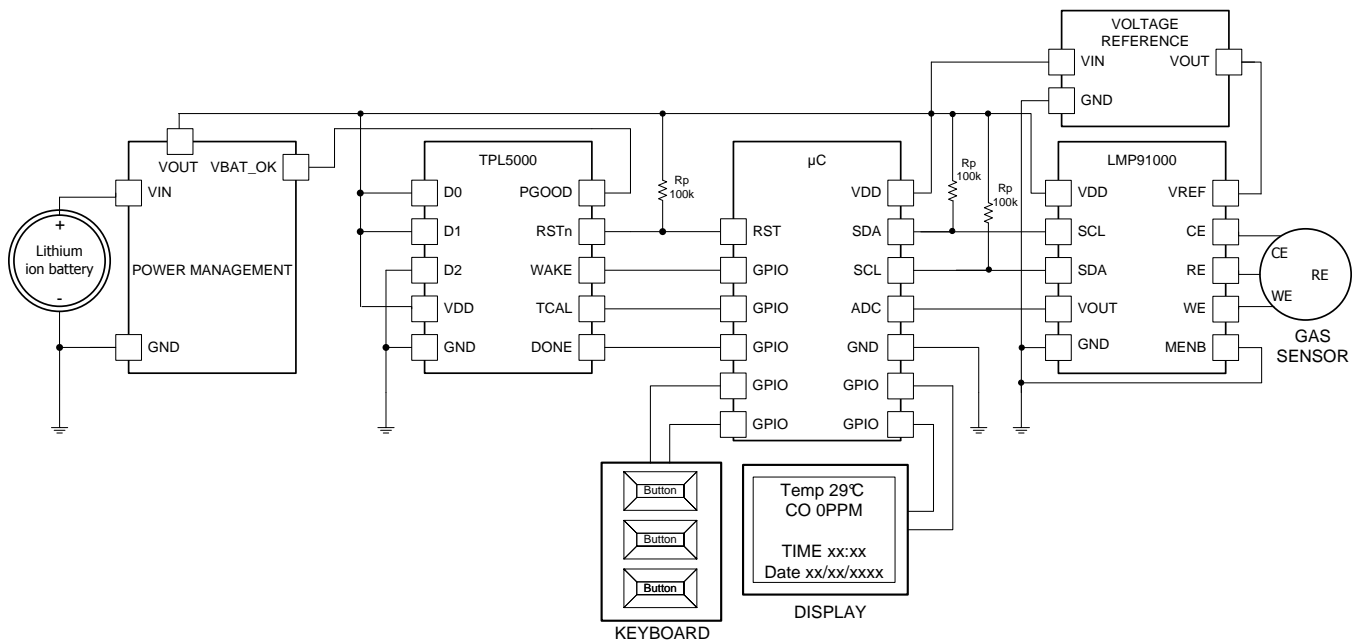

Figure 8. Data-logger

#### 9.2.1 Design Requirements

The design is driven by the low current consumption constraint. The data are usually acquired on a rate that ranges between 1 s to 10 s. The highest necessity is the maximization of the battery life. The TPL5000 helps achieve that goal because it allows putting the micro-controller in its lowest power mode.

## Typical Application (continued)

### 9.2.2 Detailed Design Procedure

When the focal constraint is the battery, the selection of a low power voltage reference, a micro-controller and display is mandatory. The first step in the design is the calculation of the power consumption of each device in the different mode of operations. An example is the LMP91000; the device has gas measurement mode, sleep mode and micro-controller in low-power mode which is normal operation. The different modes offer the possibility to select the appropriate timer interval which respect the application constraint and maximize the life of the battery.

### 9.2.3 Application Curve

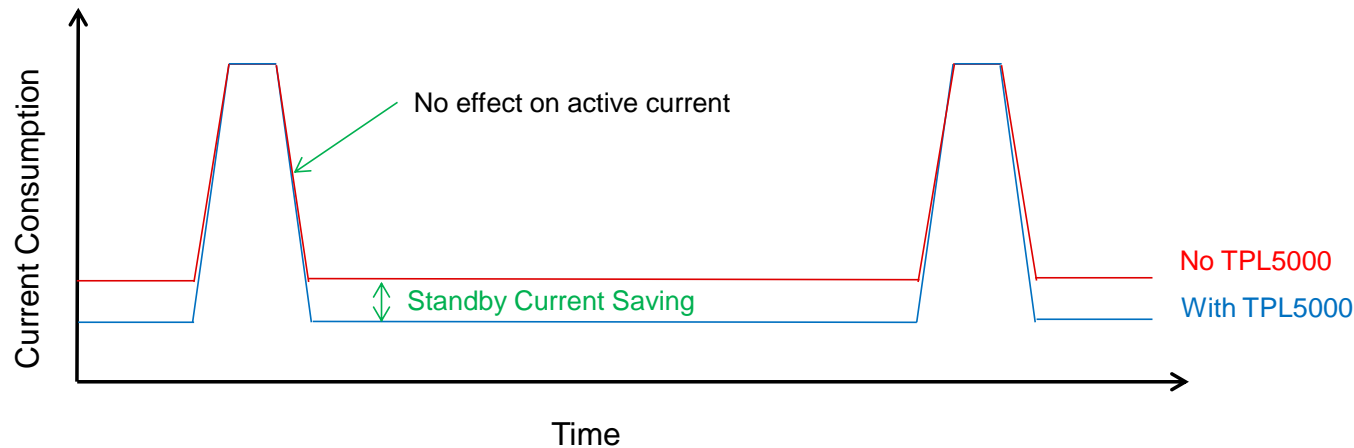

Figure 9. Effect of TPL5000 on Current Consumption

## 10 Power Supply Recommendations

The TPL5000 requires a voltage supply within 2.7 V and 5.5 V. A multilayer, ceramic-bypass X7R capacitor of 0.1 $\mu$ F between VDD and GND pin is recommended.

## 11 Layout

### 11.1 Layout Guidelines

The more sensitive pins of the TPL5000 are the digital input pins D0, D1, D2 to select the timer interval. It is mandatory to connect them to VDD or GND through short traces avoiding series resistance. It is mandatory to keep these pins far from traces of high frequency signals, such as clock or communication bus. Signal integrity of WAKE, RSTn and TCAL signal is achieved reducing parasitic capacitance on the traces between the TPL5000 and the micro-controller. In the application where the watchdog feature is not used, the DONE pin is required to be tied to TCAL pin.

### 11.2 Layout Example

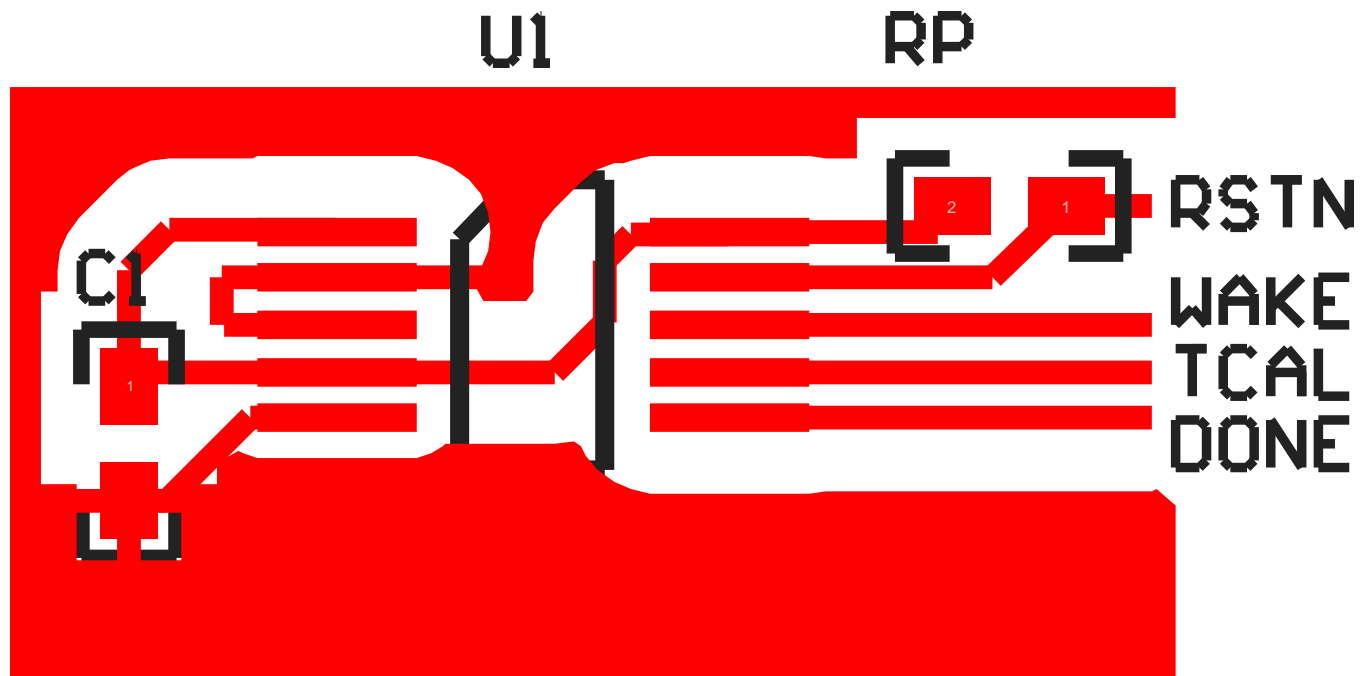

Figure 10. PCB Layout

## 12 Device and Documentation Support

### 12.1 Trademarks

All trademarks are the property of their respective owners.

### 12.2 Electrostatic Discharge Caution



These devices have limited built-in ESD protection. The leads should be shorted together or the device placed in conductive foam during storage or handling to prevent electrostatic damage to the MOS gates.

### 12.3 Glossary

[SLYZ022](#) — *TI Glossary*.

This glossary lists and explains terms, acronyms, and definitions.

## 13 Mechanical, Packaging, and Orderable Information

The following pages include mechanical, packaging, and orderable information. This information is the most current data available for the designated devices. This data is subject to change without notice and revision of this document. For browser-based versions of this data sheet, refer to the left-hand navigation.

**PACKAGING INFORMATION**

Orderable Device	Status (1)	Package Type	Package Drawing	Pins	Package Qty	Eco Plan (2)	Lead/Ball Finish (6)	MSL Peak Temp (3)	Op Temp (°C)	Device Marking (4/5)	Samples
TPL5000DGSR	ACTIVE	VSSOP	DGS	10	3500	Green (RoHS & no Sb/Br)	CU SN	Level-1-260C-UNLIM	-40 to 105	ARAA	<a href="#">Samples</a>
TPL5000DGST	ACTIVE	VSSOP	DGS	10	250	Green (RoHS & no Sb/Br)	CU SN	Level-1-260C-UNLIM	-40 to 105	ARAA	<a href="#">Samples</a>

(1) The marketing status values are defined as follows:

**ACTIVE:** Product device recommended for new designs.

**LIFEBUY:** TI has announced that the device will be discontinued, and a lifetime-buy period is in effect.

**NRND:** Not recommended for new designs. Device is in production to support existing customers, but TI does not recommend using this part in a new design.

**PREVIEW:** Device has been announced but is not in production. Samples may or may not be available.

**OBSELETE:** TI has discontinued the production of the device.

(2) Eco Plan - The planned eco-friendly classification: Pb-Free (RoHS), Pb-Free (RoHS Exempt), or Green (RoHS & no Sb/Br) - please check <http://www.ti.com/productcontent> for the latest availability information and additional product content details.

**TBD:** The Pb-Free/Green conversion plan has not been defined.

**Pb-Free (RoHS):** TI's terms "Lead-Free" or "Pb-Free" mean semiconductor products that are compatible with the current RoHS requirements for all 6 substances, including the requirement that lead not exceed 0.1% by weight in homogeneous materials. Where designed to be soldered at high temperatures, TI Pb-Free products are suitable for use in specified lead-free processes.

**Pb-Free (RoHS Exempt):** This component has a RoHS exemption for either 1) lead-based flip-chip solder bumps used between the die and package, or 2) lead-based die adhesive used between the die and leadframe. The component is otherwise considered Pb-Free (RoHS compatible) as defined above.

**Green (RoHS & no Sb/Br):** TI defines "Green" to mean Pb-Free (RoHS compatible), and free of Bromine (Br) and Antimony (Sb) based flame retardants (Br or Sb do not exceed 0.1% by weight in homogeneous material)

(3) MSL, Peak Temp. - The Moisture Sensitivity Level rating according to the JEDEC industry standard classifications, and peak solder temperature.

(4) There may be additional marking, which relates to the logo, the lot trace code information, or the environmental category on the device.

(5) Multiple Device Markings will be inside parentheses. Only one Device Marking contained in parentheses and separated by a "~" will appear on a device. If a line is indented then it is a continuation of the previous line and the two combined represent the entire Device Marking for that device.

(6) Lead/Ball Finish - Orderable Devices may have multiple material finish options. Finish options are separated by a vertical ruled line. Lead/Ball Finish values may wrap to two lines if the finish value exceeds the maximum column width.

**Important Information and Disclaimer:** The information provided on this page represents TI's knowledge and belief as of the date that it is provided. TI bases its knowledge and belief on information provided by third parties, and makes no representation or warranty as to the accuracy of such information. Efforts are underway to better integrate information from third parties. TI has taken and continues to take reasonable steps to provide representative and accurate information but may not have conducted destructive testing or chemical analysis on incoming materials and chemicals. TI and TI suppliers consider certain information to be proprietary, and thus CAS numbers and other limited information may not be available for release.

In no event shall TI's liability arising out of such information exceed the total purchase price of the TI part(s) at issue in this document sold by TI to Customer on an annual basis.

## TAPE AND REEL INFORMATION



### QUADRANT ASSIGNMENTS FOR PIN 1 ORIENTATION IN TAPE



\*All dimensions are nominal

Device	Package Type	Package Drawing	Pins	SPQ	Reel Diameter (mm)	Reel Width W1 (mm)	A0 (mm)	B0 (mm)	K0 (mm)	P1 (mm)	W (mm)	Pin1 Quadrant
TPL5000DGSR	VSSOP	DGS	10	3500	330.0	12.4	5.3	3.4	1.4	8.0	12.0	Q1
TPL5000DGST	VSSOP	DGS	10	250	178.0	12.4	5.3	3.4	1.4	8.0	12.0	Q1

**TAPE AND REEL BOX DIMENSIONS**

\*All dimensions are nominal

Device	Package Type	Package Drawing	Pins	SPQ	Length (mm)	Width (mm)	Height (mm)
TPL5000DGSR	VSSOP	DGS	10	3500	367.0	367.0	35.0
TPL5000DGST	VSSOP	DGS	10	250	210.0	185.0	35.0

DGS (S-PDSO-G10)

PLASTIC SMALL-OUTLINE PACKAGE

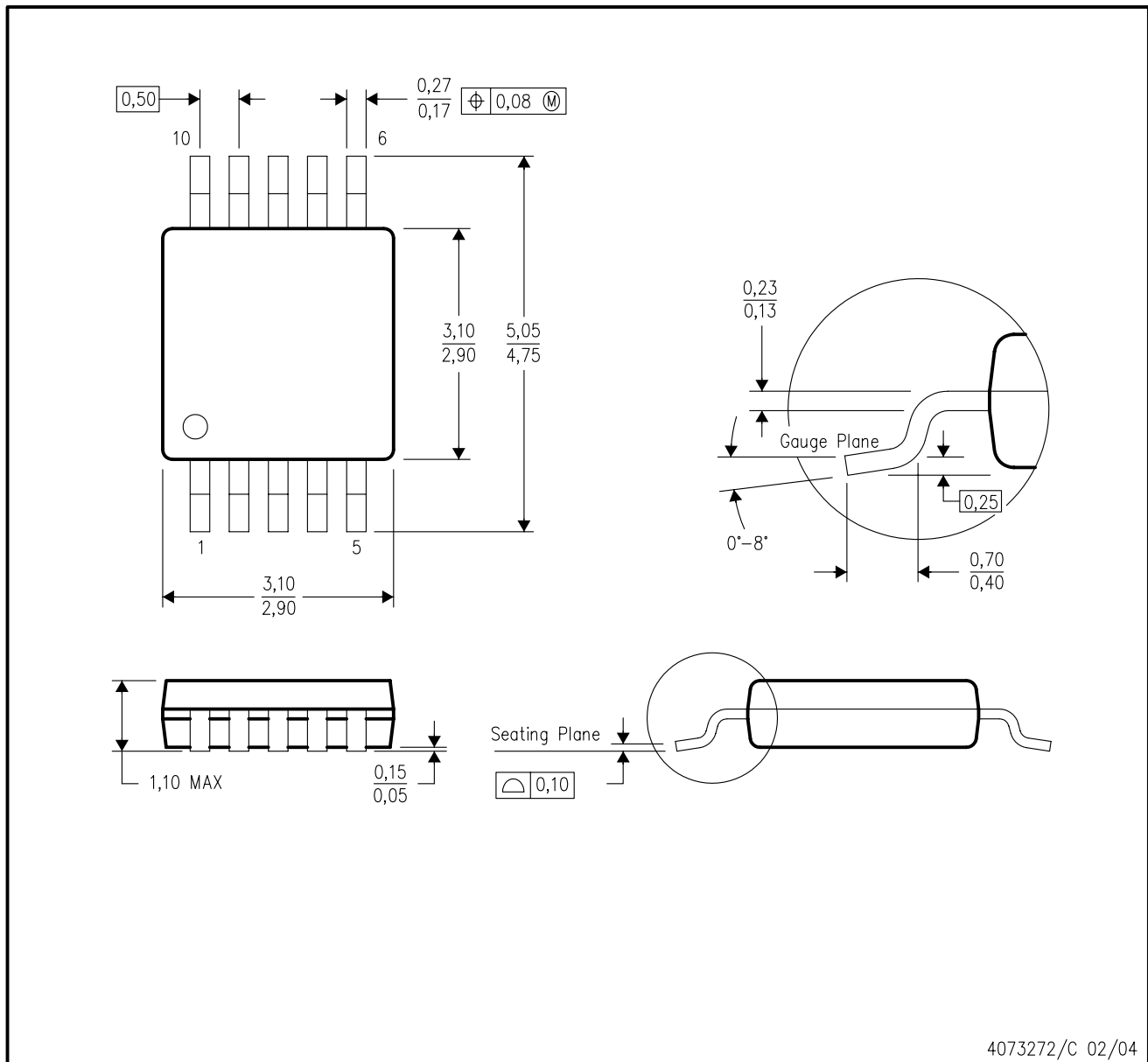

4073272/C 02/04

- NOTES:
- A. All linear dimensions are in millimeters.
  - B. This drawing is subject to change without notice.
  - C. Body dimensions do not include mold flash or protrusion.
  - D. Falls within JEDEC MO-187 variation BA.

## IMPORTANT NOTICE

Texas Instruments Incorporated and its subsidiaries (TI) reserve the right to make corrections, enhancements, improvements and other changes to its semiconductor products and services per JESD46, latest issue, and to discontinue any product or service per JESD48, latest issue. Buyers should obtain the latest relevant information before placing orders and should verify that such information is current and complete. All semiconductor products (also referred to herein as "components") are sold subject to TI's terms and conditions of sale supplied at the time of order acknowledgment.

TI warrants performance of its components to the specifications applicable at the time of sale, in accordance with the warranty in TI's terms and conditions of sale of semiconductor products. Testing and other quality control techniques are used to the extent TI deems necessary to support this warranty. Except where mandated by applicable law, testing of all parameters of each component is not necessarily performed.

TI assumes no liability for applications assistance or the design of Buyers' products. Buyers are responsible for their products and applications using TI components. To minimize the risks associated with Buyers' products and applications, Buyers should provide adequate design and operating safeguards.

TI does not warrant or represent that any license, either express or implied, is granted under any patent right, copyright, mask work right, or other intellectual property right relating to any combination, machine, or process in which TI components or services are used. Information published by TI regarding third-party products or services does not constitute a license to use such products or services or a warranty or endorsement thereof. Use of such information may require a license from a third party under the patents or other intellectual property of the third party, or a license from TI under the patents or other intellectual property of TI.

Reproduction of significant portions of TI information in TI data books or data sheets is permissible only if reproduction is without alteration and is accompanied by all associated warranties, conditions, limitations, and notices. TI is not responsible or liable for such altered documentation. Information of third parties may be subject to additional restrictions.

Resale of TI components or services with statements different from or beyond the parameters stated by TI for that component or service voids all express and any implied warranties for the associated TI component or service and is an unfair and deceptive business practice. TI is not responsible or liable for any such statements.

Buyer acknowledges and agrees that it is solely responsible for compliance with all legal, regulatory and safety-related requirements concerning its products, and any use of TI components in its applications, notwithstanding any applications-related information or support that may be provided by TI. Buyer represents and agrees that it has all the necessary expertise to create and implement safeguards which anticipate dangerous consequences of failures, monitor failures and their consequences, lessen the likelihood of failures that might cause harm and take appropriate remedial actions. Buyer will fully indemnify TI and its representatives against any damages arising out of the use of any TI components in safety-critical applications.

In some cases, TI components may be promoted specifically to facilitate safety-related applications. With such components, TI's goal is to help enable customers to design and create their own end-product solutions that meet applicable functional safety standards and requirements. Nonetheless, such components are subject to these terms.

No TI components are authorized for use in FDA Class III (or similar life-critical medical equipment) unless authorized officers of the parties have executed a special agreement specifically governing such use.

Only those TI components which TI has specifically designated as military grade or "enhanced plastic" are designed and intended for use in military/aerospace applications or environments. Buyer acknowledges and agrees that any military or aerospace use of TI components which have **not** been so designated is solely at the Buyer's risk, and that Buyer is solely responsible for compliance with all legal and regulatory requirements in connection with such use.

TI has specifically designated certain components as meeting ISO/TS16949 requirements, mainly for automotive use. In any case of use of non-designated products, TI will not be responsible for any failure to meet ISO/TS16949.

### Products

Audio	<a href="http://www.ti.com/audio">www.ti.com/audio</a>
Amplifiers	<a href="http://amplifier.ti.com">amplifier.ti.com</a>
Data Converters	<a href="http://dataconverter.ti.com">dataconverter.ti.com</a>
DLP® Products	<a href="http://www.dlp.com">www.dlp.com</a>
DSP	<a href="http://dsp.ti.com">dsp.ti.com</a>
Clocks and Timers	<a href="http://www.ti.com/clocks">www.ti.com/clocks</a>
Interface	<a href="http://interface.ti.com">interface.ti.com</a>
Logic	<a href="http://logic.ti.com">logic.ti.com</a>
Power Mgmt	<a href="http://power.ti.com">power.ti.com</a>
Microcontrollers	<a href="http://microcontroller.ti.com">microcontroller.ti.com</a>
RFID	<a href="http://www.ti-rfid.com">www.ti-rfid.com</a>
OMAP Applications Processors	<a href="http://www.ti.com/omap">www.ti.com/omap</a>
Wireless Connectivity	<a href="http://www.ti.com/wirelessconnectivity">www.ti.com/wirelessconnectivity</a>

### Applications

Automotive and Transportation	<a href="http://www.ti.com/automotive">www.ti.com/automotive</a>
Communications and Telecom	<a href="http://www.ti.com/communications">www.ti.com/communications</a>
Computers and Peripherals	<a href="http://www.ti.com/computers">www.ti.com/computers</a>
Consumer Electronics	<a href="http://www.ti.com/consumer-apps">www.ti.com/consumer-apps</a>
Energy and Lighting	<a href="http://www.ti.com/energy">www.ti.com/energy</a>
Industrial	<a href="http://www.ti.com/industrial">www.ti.com/industrial</a>
Medical	<a href="http://www.ti.com/medical">www.ti.com/medical</a>
Security	<a href="http://www.ti.com/security">www.ti.com/security</a>
Space, Avionics and Defense	<a href="http://www.ti.com/space-avionics-defense">www.ti.com/space-avionics-defense</a>
Video and Imaging	<a href="http://www.ti.com/video">www.ti.com/video</a>

### TI E2E Community

[e2e.ti.com](http://e2e.ti.com)