

TPL5100 Nano-Power Programmable Timer With MOS Driver

1 Features

- Supply Voltage from 1.8 V to 5.0 V
- Selectable Timer Intervals, 16 to 1024 seconds
- Current Consumption 30 nA (typical, at 2.5 V)

2 Applications

- Battery-Powered Systems
- Energy Harvesting Systems
- Remote Data-Logger
- Sensor Node
- Power-Gating Applications
- Building Automation
- Low-Power Wireless
- Consumer Electronics

3 Description

The TPL5100 is a long-term timer IC optimized for low-power applications. The TPL5100 can replace a microcontroller's internal timer, allowing the microcontroller to stay completely off instead of running a timer, providing a total power consumption reduction of 60 to 80%. The TPL5100 is designed for use in power cycled applications and provides selectable timing from 16 seconds to 1024 seconds. The TPL5100 can also monitor a battery management IC via a power-good digital input and power on the microcontroller only when a good supply voltage is present. The device is packaged in a 10-pin VSSOP package.

Device Information⁽¹⁾

PART NUMBER	PACKAGE	BODY SIZE (NOM)
TPL5100	VSSOP (10)	3.00 mm x 3.00 mm

(1) For all available packages, see the orderable addendum at the end of the datasheet.

Simplified Application Schematic

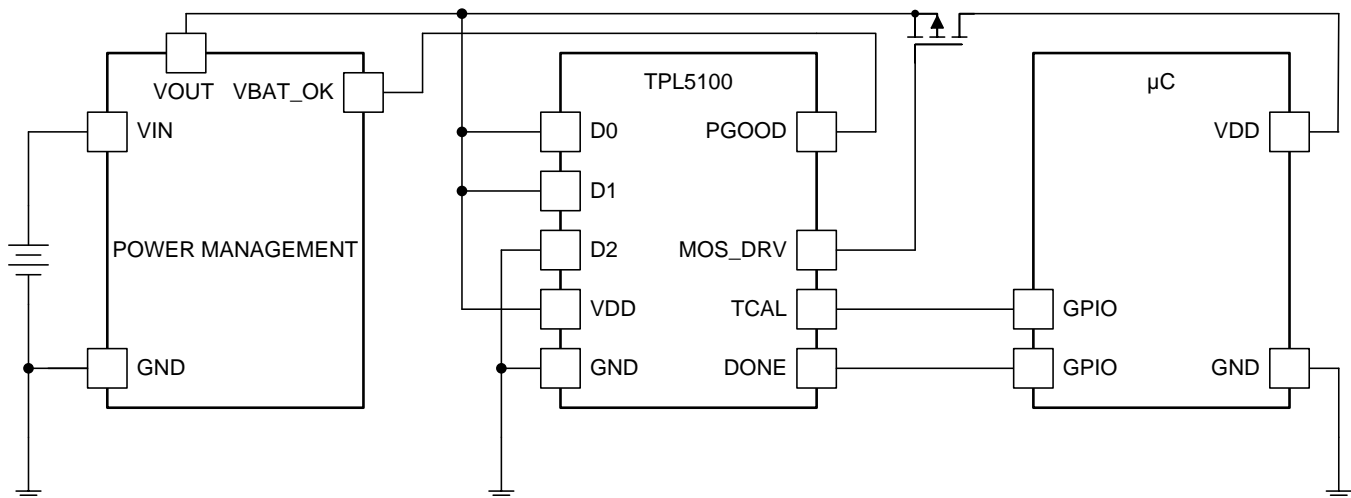

Table of Contents

1 Features	1	7.2 Functional Block Diagram	8
2 Applications	1	7.3 Feature Description	8
3 Description	1	7.4 Device Functional Modes	10
4 Revision History	2	8 Application and Implementation	11
5 Pin Configuration and Functions	3	8.1 Application Information	11
6 Specifications	4	8.2 Typical Application	11
6.1 Absolute Maximum Ratings	4	9 Power Supply Recommendations	13
6.2 ESD Ratings	4	10 Layout	13
6.3 Recommended Operating Ratings	4	10.1 Layout Guidelines	13
6.4 Thermal Information	4	10.2 Layout Example	13
6.5 Electrical Characteristics	5	11 Device and Documentation Support	14
6.6 Timing Requirements TCAL, MOS_DRV, DONE, PGOOD	6	11.1 Trademarks	14
6.7 Typical Characteristics	7	11.2 Electrostatic Discharge Caution	14
7 Detailed Description	8	11.3 Glossary	14
7.1 Overview	8	12 Mechanical, Packaging, and Orderable Information	14

4 Revision History

Changes from Revision B (August 2013) to Revision C	Page
• Added ESD Ratings table, Feature Description section, Device Functional Modes, Application and Implementation section, Power Supply Recommendations section, Layout section, Device and Documentation Support section, and Mechanical, Packaging, and Orderable Information section	3
• Removed T _A value.	4

5 Pin Configuration and Functions

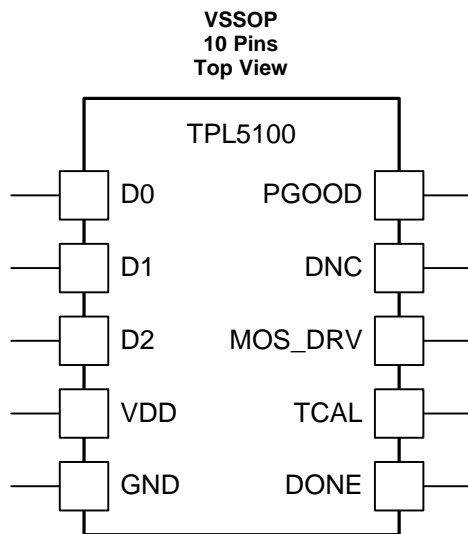

Pin Functions

PIN		I/O	DESCRIPTION	APPLICATION INFORMATION
NAME	NO.			
D0	1	I	Logic Input to set period delay (t_{DP})	Connect to GND (low logic value) or to VDD (high logic value)
D1	2	I	Logic Input to set period delay (t_{DP})	Connect to GND (low logic value) or to VDD (high logic value)
D2	3	I	Logic Input to set period delay (t_{DP})	Connect to GND (low logic value) or to VDD (high logic value)
VDD	4	P	Supply voltage	
GND	5	G	Ground	
DONE	6	I	Logic input for Watchdog functionality	
TCAL	7	O	Short duration pulse output for estimation of TPL5100 timer delay.	
MOS_DRV	8	O	Drives external MOSFET to power cycle the remaining system.	
DNC	9	–	Do Not Connect	Leave this pin floating
PGOOD	10	I	Digital power good input	

6 Specifications

6.1 Absolute Maximum Ratings⁽¹⁾⁽²⁾

	MIN	MAX	UNIT
Supply Voltage (VDD-GND)	-0.3	6	V
Input voltage	-0.3	VDD+0.3	V
Voltage between any two pins ⁽³⁾	-0.3	VDD+0.3	V
Input Current on any pin	-5	5	mA
Junction Temperature, T _J ⁽⁴⁾		150	°C
Storage temperature, T _{stg}	-65	150	°C

- (1) Stresses beyond those listed under *Absolute Maximum Ratings* may cause permanent damage to the device. These are stress ratings only, which do not imply functional operation of the device at these or any other conditions beyond those indicated under *Recommended Operating Conditions*. Exposure to absolute-maximum-rated conditions for extended periods may affect device reliability.
- (2) All voltages referenced to ground unless otherwise noted.
- (3) When the input voltage (VIN) at any pin exceeds the power supply (VDD), the current on that pin must not exceed 5 mA and the voltage must also not exceed 6.0 V.
- (4) The maximum power dissipation is a function of T_J(MAX), I_JJA, and the ambient temperature, TA. The maximum allowable power dissipation at any ambient temperature is PDMAX = (T_J(MAX) - TA) / I_JJA. All numbers apply for packages soldered directly onto a PC board.

6.2 ESD Ratings

		VALUE	UNIT
V _(ESD) Electrostatic discharge	Human-body model (HBM), per ANSI/ESDA/JEDEC JS-001 ⁽¹⁾	±2000	V
	Charged-device model (CDM), per JEDEC specification JESD22-C101 ⁽²⁾	±500	

- (1) JEDEC document JEP155 states that 500-V HBM allows safe manufacturing with a standard ESD control process.
- (2) JEDEC document JEP157 states that 250-V CDM allows safe manufacturing with a standard ESD control process.

6.3 Recommended Operating Ratings

	MIN	MAX	UNIT
Supply Voltage (VDD-GND)	1.8	5.0	V
Temperature Range	-40	105	°C

6.4 Thermal Information

THERMAL METRIC ⁽¹⁾	TPL5100	UNIT
	VSSOP	
	10 PINS	
R _{θJA} Junction-to-ambient thermal resistance	196.8	°C/W

- (1) For more information about traditional and new thermal metrics, see the *IC Package Thermal Metrics* application report, [SPRA953](#).

6.5 Electrical Characteristics⁽¹⁾

Specifications are for $T_A = T_J = 25^\circ\text{C}$, $V_{DD-GND} = 2.5\text{ V}$, unless otherwise stated.

PARAMETER		TEST CONDITIONS	MIN ⁽²⁾	TYP ⁽³⁾	MAX ⁽²⁾	UNIT
POWER SUPPLY						
IVDD	Supply current ⁽⁴⁾	PGOOD=VDD		30	50	nA
		PGOOD=GND		12		nA
TIMER						
t_{DP}	Timer Delay Period			16, 32, 64, 100, 128, 256, 512, 1024		s
				0.06 %		
				400		ppm/°C
t_{CAL}	Calibration pulse width		14.063	15.625	17.188	ms
		t_{DP} to t_{CAL} matching error ⁽⁶⁾	VDD<=3.0 V		0.1%	
t_{DONE}	DONE Pulse width ⁽⁶⁾		100			ns
t_{MOS_DRV}	MOS_DRV Pulse width			31.25		ms
DIGITAL LOGIC LEVELS						
VIH	Logic High Threshold	PGOOD, DONE	0.7xVDD			V
VIL	Logic Low Threshold	PGOOD, DONE			0.3xVDD	V
VOH	Logic output High Level	MOS_DRV, TCAL Iout = 100 uA	VDD-0.3			V
		MOS_DRV, TCAL Iout = 1 mA	VDD-0.7			V
VOL	Logic output Low Level	MOS_DRV, TCAL Iout = -100 uA			0.3	V
		MOS_DRV, TCAL Iout = -1 mA			0.7	V

- (1) *Electrical Characteristics* table values apply only for factory testing conditions at the temperature indicated. Factory testing conditions result in very limited self-heating of the device such that $T_J = T_A$.
- (2) Limits are specified by testing, design, or statistical analysis at 25°C. Limits over the operating temperature range are specified through correlations using statistical quality control (SQC) method.
- (3) Typical values represent the most likely parametric norm as determined at the time of characterization. Actual typical values may vary over time and will also depend on the application and configuration. The typical values are not tested and are not ensured on shipped production material.
- (4) The supply current doesn't take in account load and pull-up resistor current. Input pins are at GND or VDD.
- (5) Operational life time test procedure equivalent to 10 years.
- (6) Ensured by design.

6.6 Timing Requirements TCAL, MOS_DRV, DONE, PGOOD

			MIN	NOM	MAX	UNIT
$t_{r_{TCAL}}$	Rise Time TCAL	Capacitive load 15 pF		50		ns
$t_{f_{TCAL}}$	Fall Time TCAL	Capacitive load 15 pF		50		ns
$t_{r_{MOS_DRV}}$	Rise Time MOS_DRV	Capacitive load 50 pF		4		ns
$t_{f_{MOS_DRV}}$	Fall Time MOS_DRV	Capacitive load 50 pF		50		ns
$t_{D_{DONE}}$	DONE to MOS_DRV delay	Min delay		100		ns
		Max delay		$t_{DP} - 5 \times t_{CAL}$		ms
$t_{D_{TCAL}}$	TCAL to MOS_DRV delay			$t_{CAL}/2$		ms

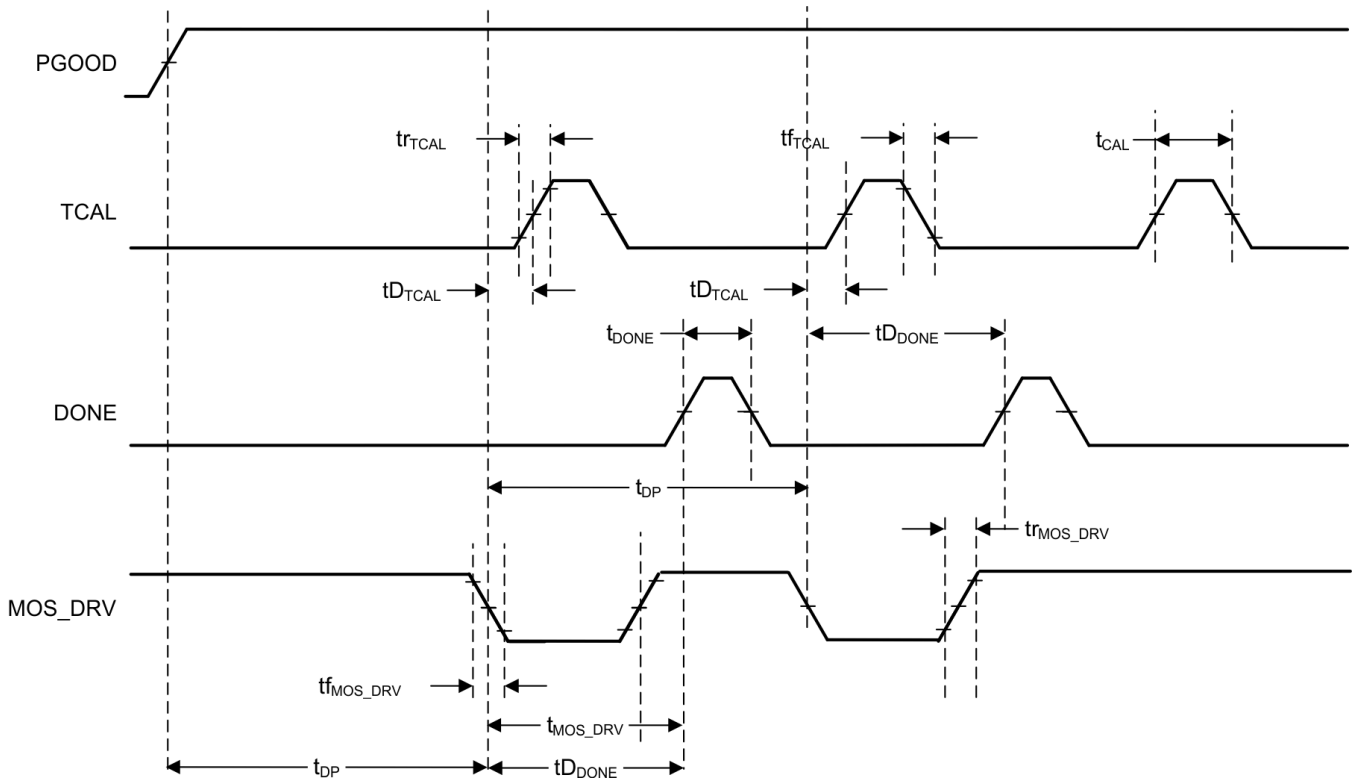

Figure 1. Timing Diagram

6.7 Typical Characteristics

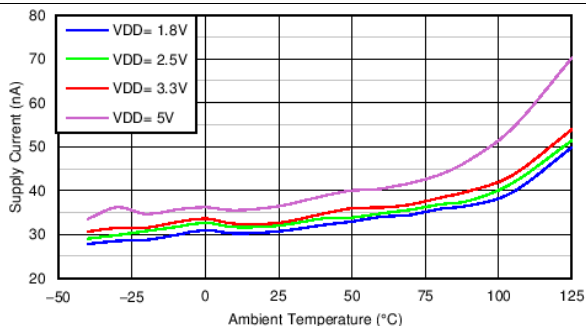

Figure 2. I_{DD} vs Temperature

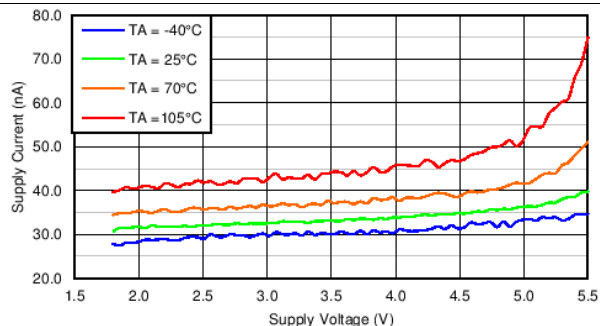

Figure 3. I_{DD} vs V_{DD}

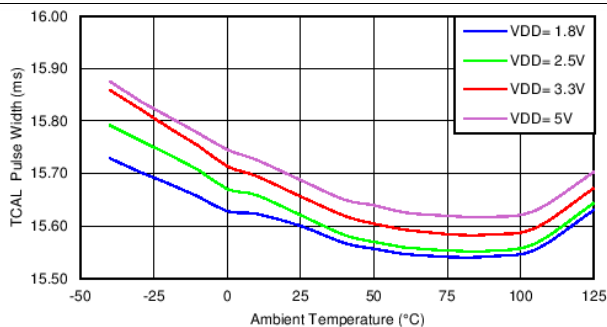

Figure 4. TCAL Pulse Width vs Temperature

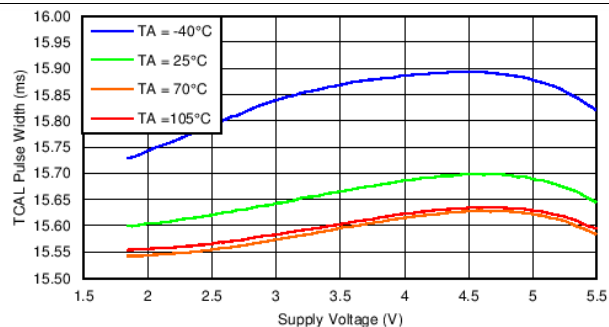

Figure 5. TCAL Pulse Width vs V_{DD}

7 Detailed Description

7.1 Overview

The TPL5100 is a long-term timer for low-power applications. The TPL5100 is designed for use in power cycled applications and provides selectable timing from 16 s to 1024 s. An additional feature is interfacing which is achieved through the TPL5100 to a power-management IC.

7.2 Functional Block Diagram

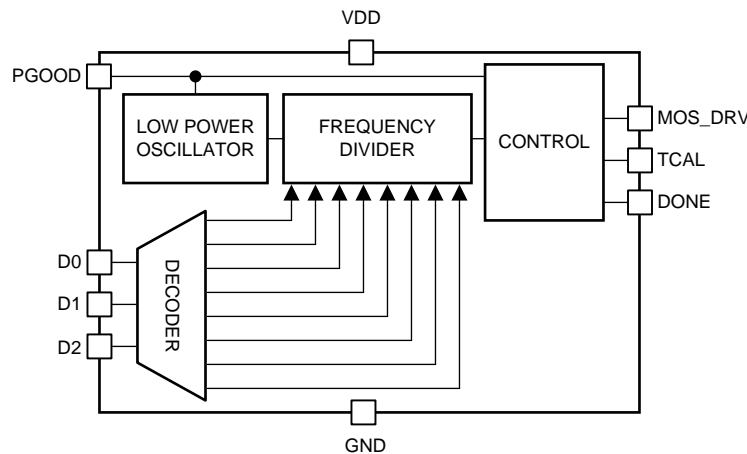

7.3 Feature Description

7.3.1 Supervisor Feature

A critical event that can corrupt the memory of a microcontroller is a voltage supply drop (supply lower than minimum operating range), and a reset of the microcontroller is mandatory if this occurs. Since the TPL5100 is the right choice in systems which stay most of the time in deep sleep or completely OFF, due to its ultra-low power consumption, it is fundamental that it takes into account the voltage drop events. The TPL5100 implements the supervisor feature when working with some power-management ICs, which indicate the status of the supply voltage with a power-good or battery-good output. The supervisory functionality is enabled by simply connecting the Battery management power-good output to the TPL5100 PGOOD pin. If this feature is not used connect the PGOOD pin to VDD.

In case the power-management IC detects a voltage drop while the microcontroller is OFF, consequently lowering the PGOOD line, the TPL5100 resets its internal counter and does not allow the micro to turn ON until the PGOOD is high again. This series of events allows the microcontroller to avoid working in an unsafe voltage supply condition. If the PGOOD signal is lowered while the microcontroller is ON, the TPL5100 turns the microcontroller OFF. The micro will be turned ON when PGOOD is high again and the selected delay is elapsed.

7.3.2 Calibration Pulse

The TPL5100 is based on an ultra-low power oscillator, which has a relatively low frequency and low accuracy; however, it shows very good cycle-to-cycle repeatability and very low temperature drift. In most of the applications, the accuracy of the oscillator is enough, but if a more accurate measure of the delay period is required, it is possible to measure the base period of the internal oscillator. A single pulse, which has the same duration as the base period of the internal oscillator, is present at the TCAL pin of the TPL5100. This pulse starts after a half period of the internal oscillator, from the falling edge of the MOS_DRV pulse.

A microcontroller-connected to the TPL5100 can routinely measure the width of the TCAL pulse, using a counter and an external crystal. Once the base period of the TPL5100 is measured, the actual time delay is calculated by multiplying the measured period by a factor, N (see [Table 1](#)), dependent upon the nominal selected time delay.

The resolution and the accuracy of the measurement depend upon the external crystal. Since the frequency of the internal oscillator of the TPL5100 is very stable, the measurement of the calibration pulse is suggested only when a high gradient of ambient temperature is observed. The measurement of the TCAL pulse is useful in battery-powered applications that implement a precise battery life counter in the microcontroller.

Feature Description (continued)

7.3.2.1 Overview of the Timing Signals MOS_DRV, TCAL, and DONE

Figure 6 shows the timing of PGOOD, MOS_DRV, and TCAL with respect to DONE. The frame, A, shows a typical sequence after the PGOOD, low to high, transition. As soon as PGOOD is high, the internal oscillator is powered ON. At the end of the delay period (t_{DP}), a MOS enable signal (MOS_DRV), followed by a calibration pulse, TCAL, is sent out. The calibration pulse starts after a half period of the internal oscillator from the falling edge of the MOS_DRV signal, and lasts one internal oscillator period. A "DONE" signal is received before the end of the MOS_DRV pulse. As soon as the TPL5100 receives the DONE signal, the counter resets and MOS_DRV and TCAL return to default conditions (MOS_DRV signal high and TCAL signal low).

The frame, B, shows a non-standard sequence. A "DONE" signal has not been received before the end of the MOS_DRV pulse. The MOS_DRV signal stays low for 2 internal oscillator periods. The calibration pulse starts after a half period of the internal oscillator from the falling edge of the MOS_DRV signal, and lasts one internal oscillator period. The external power gating MOS stays ON for 2 internal oscillator periods.

The frame, C, shows a standard sequence, but in this case, the TPL5100 receives the DONE signal when MOS_DRV is high and TCAL pulse is still high. As soon as the TPL5100 recognizes the DONE signal, the counter resets and MOS_DRV and TCAL return to default conditions (MOS_DRV signal high and TCAL signal low). The external power-gating MOS stays ON for the execution time of the program of the connected microcontroller.

The frame, D, shows a typical PGOOD, high to low transition. As soon as PGOOD is low, the internal oscillator is powered OFF and the digital output pins, TCAL and MOS_DRV, are asynchronously reset by the falling edge of the PGOOD signal, such that TCAL resets at low logical values, while MOS_DRV resets at a high logical value. The external power gating MOS stays ON less than the execution time of the program of the connected microcontroller.

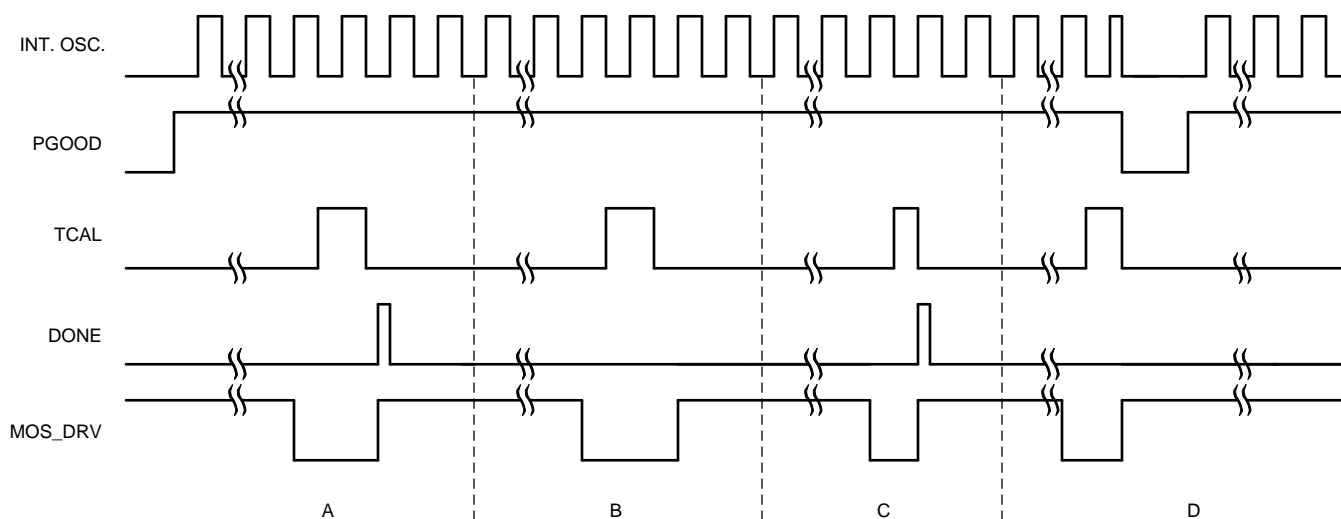

Figure 6. Timing MOS_DRV, TCAL

7.3.3 Configuration and Interface

The time interval between 2 adjacent pulses is selectable through 3 digital input pins (D0, D1, D2) that can be strapped to either VDD (1) or GND (0). Eight possible time delays can be selected, as shown in Table 1.

Table 1. Timer Delay Period

D2	D1	D0	Time (s)	Factor N
0	0	0	16	2^{10}
0	0	1	32	2^{11}
0	1	0	64	2^{12}
0	1	1	100	$100 \cdot 2^6$

Feature Description (continued)
Table 1. Timer Delay Period (continued)

D2	D1	D0	Time (s)	Factor N
1	0	0	128	2^{13}
1	0	1	256	2^{14}
1	1	0	512	2^{15}
1	1	1	1024	2^{16}

7.4 Device Functional Modes

The TPL5100 is a long-term timer with a watchdog feature for low-power applications. The TPL5100 is designed for use in interrupt-driven applications and provides selectable timing from 1 s to 64 s. An additional supervisor feature is achieved through interfacing the TPL5100 to a power-management IC.

8 Application and Implementation

NOTE

Information in the following applications sections is not part of the TI component specification, and TI does not warrant its accuracy or completeness. TI's customers are responsible for determining suitability of components for their purposes. Customers should validate and test their design implementation to confirm system functionality.

8.1 Application Information

In battery powered applications the design of the system is driven by low-current consumption. The TPL5100 is suitable in the applications where there is the needs to monitor environment conditions in remote site at long fixed timer interval. Occasionally in these applications the micro is kept on to enable the watchdog and count the elapsed time. Often due to the high frequency clock of the microcontrollers, a special structure must be configured to count for several seconds. The TPL5100 can mimic the same job, by completely turning off the micro and sometimes the entire power channel; this results in burning only tens of nA.

8.2 Typical Application

The TPL5100 can be used in environment sensor nodes such as humidity and temperature sensor node. The sensor node has to measure the humidity and the temperature and transmit the data through a low power RF micro such as the CC2530. Since the temperature and the humidity in home application do not change so fast, the measurement and the transmission of the data can be done at very low rate, such as every 30 seconds. The RF micro should spend most of the time in counting the elapsed time, but using the TPL5100 it is possible to complete turn off the RF micro and enlarge the battery life. The TPL5100 will turn on the RF micro when the programmed timer interval elapses.

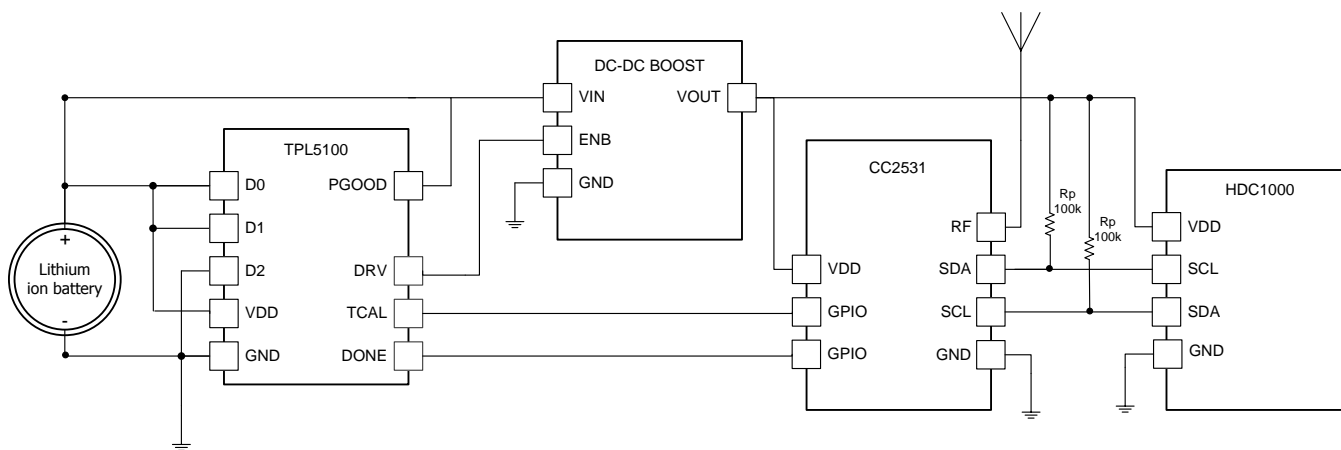

Figure 7. Sensor Node

8.2.1 Design Requirements

The design is driven by the low current consumption constraint. The data are usually acquired at a rate between 30 s to 60 s. The highest necessity is the maximization of the battery life. The TPL5100 helps achieve this goal because it allows turning off the RF micro.

8.2.2 Detailed Design Procedure

When the focal constraint is the battery life, the selection of a low-power voltage regulator and low-leakage MOSFET to power gate the microcontroller is mandatory. The first step in the design is the calculation of the power consumption of each device in the different mode of operations. An example is the HDC1000, in measurement mode the RF micro is in normal operation and transmission. The different modes offer the possibility to select the appropriate timer interval which respect the application constraint and maximize the life of the battery.

Typical Application (continued)

8.2.3 Application Curve

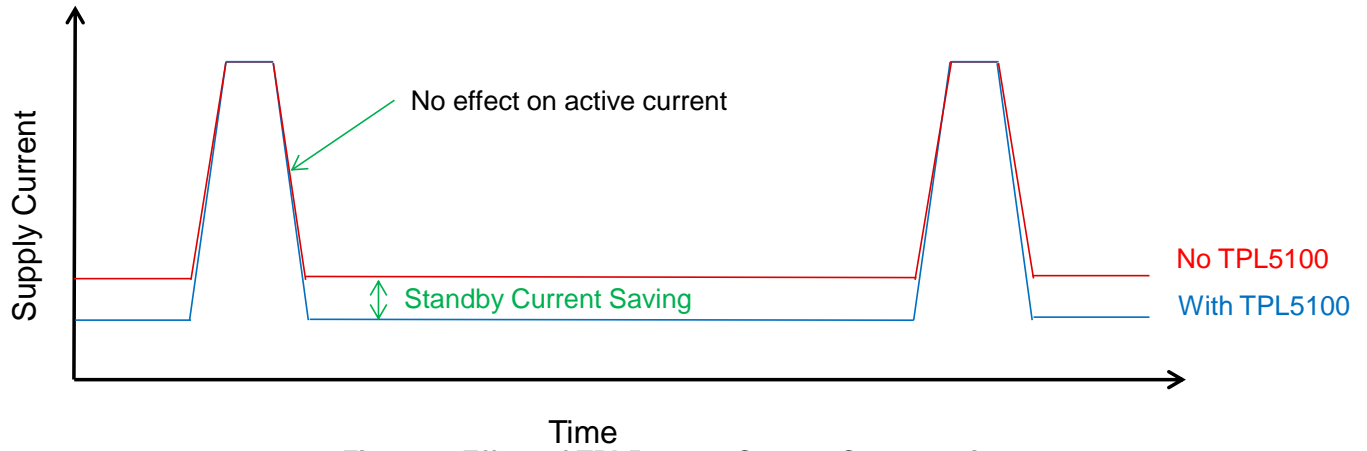

Figure 8. Effect of TPL5100 on Current Consumption

9 Power Supply Recommendations

The TPL5100 requires a voltage supply within 2.7 V and 5.5 V. A multilayer, ceramic-bypass X7R capacitor of 0.1µF between VDD and GND pin is recommended.

10 Layout

10.1 Layout Guidelines

The more sensitive pins of the TPL5100 are the digital input pins D0, D1, D2 to select the timer interval. It is mandatory to connect them to VDD or GND through short traces avoiding series resistance. Moreover, it is mandatory to keep these pins far from traces of high frequency signals, such as clock or communication bus. Signal integrity of DRV and TCAL signal is achieved reducing parasitic capacitance on the traces between the TPL5100 and the microcontroller.

10.2 Layout Example

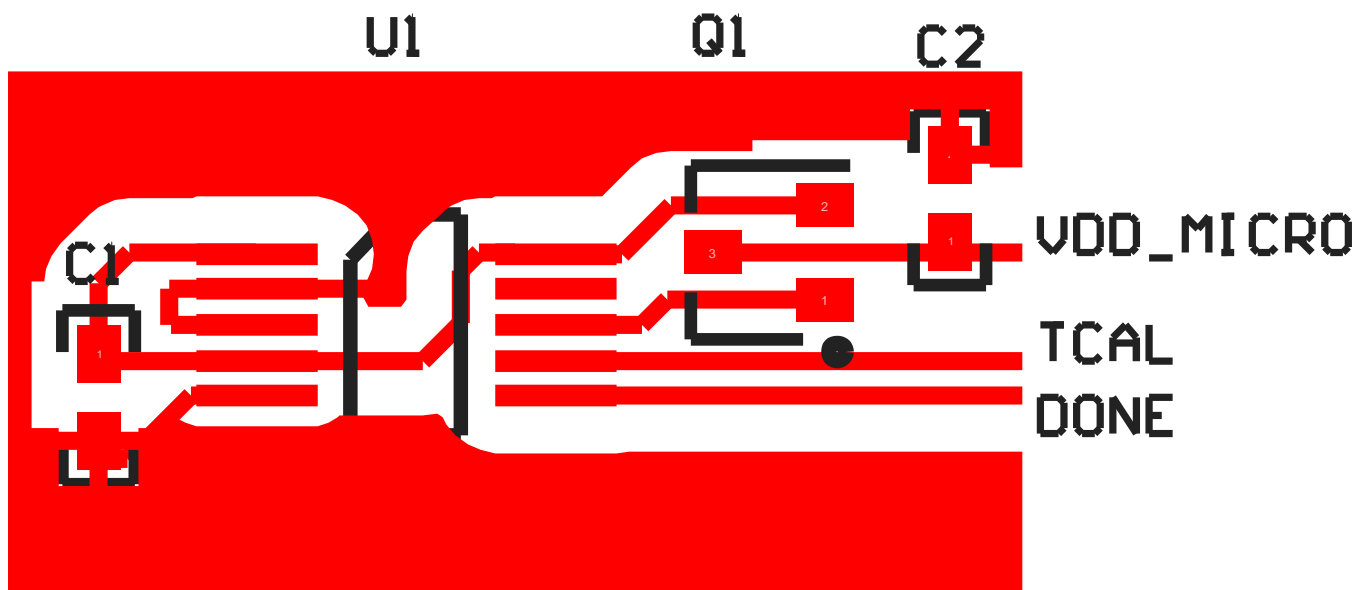

Figure 9. Board Layout

11 Device and Documentation Support

11.1 Trademarks

All trademarks are the property of their respective owners.

11.2 Electrostatic Discharge Caution



These devices have limited built-in ESD protection. The leads should be shorted together or the device placed in conductive foam during storage or handling to prevent electrostatic damage to the MOS gates.

11.3 Glossary

[SLYZ022](#) — *TI Glossary*.

This glossary lists and explains terms, acronyms, and definitions.

12 Mechanical, Packaging, and Orderable Information

The following pages include mechanical, packaging, and orderable information. This information is the most current data available for the designated devices. This data is subject to change without notice and revision of this document. For browser-based versions of this data sheet, refer to the left-hand navigation.

PACKAGING INFORMATION

Orderable Device	Status (1)	Package Type	Package Drawing	Pins	Package Qty	Eco Plan (2)	Lead/Ball Finish (6)	MSL Peak Temp (3)	Op Temp (°C)	Device Marking (4/5)	Samples
TPL5100DGSR	ACTIVE	VSSOP	DGS	10	3500	Green (RoHS & no Sb/Br)	CU SN	Level-1-260C-UNLIM	-40 to 105	ASAA	Samples
TPL5100DGST	ACTIVE	VSSOP	DGS	10	250	Green (RoHS & no Sb/Br)	CU SN	Level-1-260C-UNLIM	-40 to 105	ASAA	Samples

(1) The marketing status values are defined as follows:

ACTIVE: Product device recommended for new designs.

LIFEBUY: TI has announced that the device will be discontinued, and a lifetime-buy period is in effect.

NRND: Not recommended for new designs. Device is in production to support existing customers, but TI does not recommend using this part in a new design.

PREVIEW: Device has been announced but is not in production. Samples may or may not be available.

OBSOLETE: TI has discontinued the production of the device.

(2) Eco Plan - The planned eco-friendly classification: Pb-Free (RoHS), Pb-Free (RoHS Exempt), or Green (RoHS & no Sb/Br) - please check <http://www.ti.com/productcontent> for the latest availability information and additional product content details.

TBD: The Pb-Free/Green conversion plan has not been defined.

Pb-Free (RoHS): TI's terms "Lead-Free" or "Pb-Free" mean semiconductor products that are compatible with the current RoHS requirements for all 6 substances, including the requirement that lead not exceed 0.1% by weight in homogeneous materials. Where designed to be soldered at high temperatures, TI Pb-Free products are suitable for use in specified lead-free processes.

Pb-Free (RoHS Exempt): This component has a RoHS exemption for either 1) lead-based flip-chip solder bumps used between the die and package, or 2) lead-based die adhesive used between the die and leadframe. The component is otherwise considered Pb-Free (RoHS compatible) as defined above.

Green (RoHS & no Sb/Br): TI defines "Green" to mean Pb-Free (RoHS compatible), and free of Bromine (Br) and Antimony (Sb) based flame retardants (Br or Sb do not exceed 0.1% by weight in homogeneous material)

(3) MSL, Peak Temp. - The Moisture Sensitivity Level rating according to the JEDEC industry standard classifications, and peak solder temperature.

(4) There may be additional marking, which relates to the logo, the lot trace code information, or the environmental category on the device.

(5) Multiple Device Markings will be inside parentheses. Only one Device Marking contained in parentheses and separated by a "~" will appear on a device. If a line is indented then it is a continuation of the previous line and the two combined represent the entire Device Marking for that device.

(6) Lead/Ball Finish - Orderable Devices may have multiple material finish options. Finish options are separated by a vertical ruled line. Lead/Ball Finish values may wrap to two lines if the finish value exceeds the maximum column width.

Important Information and Disclaimer: The information provided on this page represents TI's knowledge and belief as of the date that it is provided. TI bases its knowledge and belief on information provided by third parties, and makes no representation or warranty as to the accuracy of such information. Efforts are underway to better integrate information from third parties. TI has taken and continues to take reasonable steps to provide representative and accurate information but may not have conducted destructive testing or chemical analysis on incoming materials and chemicals. TI and TI suppliers consider certain information to be proprietary, and thus CAS numbers and other limited information may not be available for release.

In no event shall TI's liability arising out of such information exceed the total purchase price of the TI part(s) at issue in this document sold by TI to Customer on an annual basis.

TAPE AND REEL INFORMATION

QUADRANT ASSIGNMENTS FOR PIN 1 ORIENTATION IN TAPE

*All dimensions are nominal

Device	Package Type	Package Drawing	Pins	SPQ	Reel Diameter (mm)	Reel Width W1 (mm)	A0 (mm)	B0 (mm)	K0 (mm)	P1 (mm)	W (mm)	Pin1 Quadrant
TPL5100DGSR	VSSOP	DGS	10	3500	330.0	12.4	5.3	3.4	1.4	8.0	12.0	Q1
TPL5100DGST	VSSOP	DGS	10	250	178.0	12.4	5.3	3.4	1.4	8.0	12.0	Q1

TAPE AND REEL BOX DIMENSIONS

*All dimensions are nominal

Device	Package Type	Package Drawing	Pins	SPQ	Length (mm)	Width (mm)	Height (mm)
TPL5100DGSR	VSSOP	DGS	10	3500	367.0	367.0	35.0
TPL5100DGST	VSSOP	DGS	10	250	210.0	185.0	35.0

DGS (S-PDSO-G10)

PLASTIC SMALL-OUTLINE PACKAGE

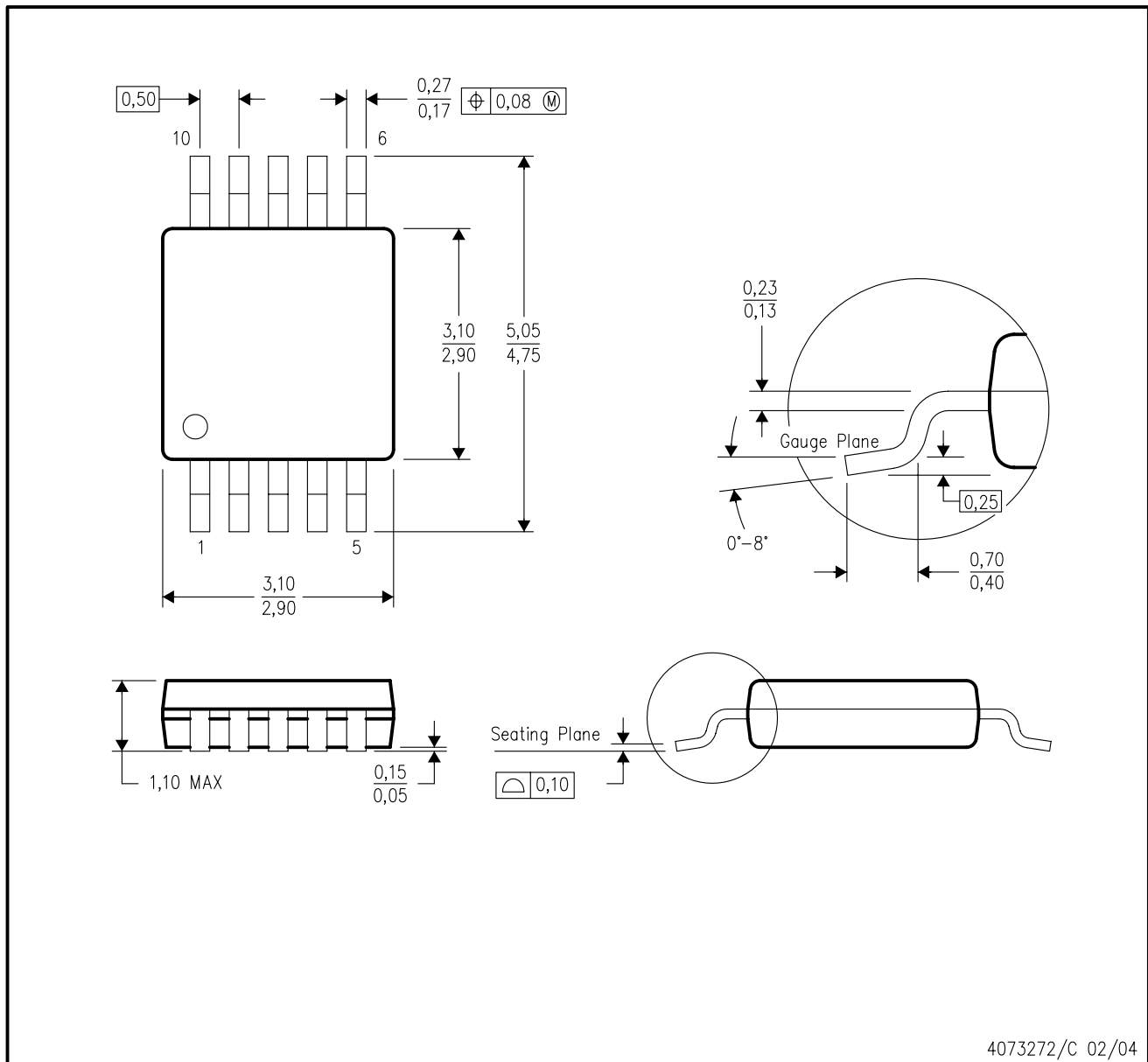

- NOTES:
- A. All linear dimensions are in millimeters.
 - B. This drawing is subject to change without notice.
 - C. Body dimensions do not include mold flash or protrusion.
 - D. Falls within JEDEC MO-187 variation BA.

IMPORTANT NOTICE

Texas Instruments Incorporated and its subsidiaries (TI) reserve the right to make corrections, enhancements, improvements and other changes to its semiconductor products and services per JESD46, latest issue, and to discontinue any product or service per JESD48, latest issue. Buyers should obtain the latest relevant information before placing orders and should verify that such information is current and complete. All semiconductor products (also referred to herein as "components") are sold subject to TI's terms and conditions of sale supplied at the time of order acknowledgment.

TI warrants performance of its components to the specifications applicable at the time of sale, in accordance with the warranty in TI's terms and conditions of sale of semiconductor products. Testing and other quality control techniques are used to the extent TI deems necessary to support this warranty. Except where mandated by applicable law, testing of all parameters of each component is not necessarily performed.

TI assumes no liability for applications assistance or the design of Buyers' products. Buyers are responsible for their products and applications using TI components. To minimize the risks associated with Buyers' products and applications, Buyers should provide adequate design and operating safeguards.

TI does not warrant or represent that any license, either express or implied, is granted under any patent right, copyright, mask work right, or other intellectual property right relating to any combination, machine, or process in which TI components or services are used. Information published by TI regarding third-party products or services does not constitute a license to use such products or services or a warranty or endorsement thereof. Use of such information may require a license from a third party under the patents or other intellectual property of the third party, or a license from TI under the patents or other intellectual property of TI.

Reproduction of significant portions of TI information in TI data books or data sheets is permissible only if reproduction is without alteration and is accompanied by all associated warranties, conditions, limitations, and notices. TI is not responsible or liable for such altered documentation. Information of third parties may be subject to additional restrictions.

Resale of TI components or services with statements different from or beyond the parameters stated by TI for that component or service voids all express and any implied warranties for the associated TI component or service and is an unfair and deceptive business practice. TI is not responsible or liable for any such statements.

Buyer acknowledges and agrees that it is solely responsible for compliance with all legal, regulatory and safety-related requirements concerning its products, and any use of TI components in its applications, notwithstanding any applications-related information or support that may be provided by TI. Buyer represents and agrees that it has all the necessary expertise to create and implement safeguards which anticipate dangerous consequences of failures, monitor failures and their consequences, lessen the likelihood of failures that might cause harm and take appropriate remedial actions. Buyer will fully indemnify TI and its representatives against any damages arising out of the use of any TI components in safety-critical applications.

In some cases, TI components may be promoted specifically to facilitate safety-related applications. With such components, TI's goal is to help enable customers to design and create their own end-product solutions that meet applicable functional safety standards and requirements. Nonetheless, such components are subject to these terms.

No TI components are authorized for use in FDA Class III (or similar life-critical medical equipment) unless authorized officers of the parties have executed a special agreement specifically governing such use.

Only those TI components which TI has specifically designated as military grade or "enhanced plastic" are designed and intended for use in military/aerospace applications or environments. Buyer acknowledges and agrees that any military or aerospace use of TI components which have **not** been so designated is solely at the Buyer's risk, and that Buyer is solely responsible for compliance with all legal and regulatory requirements in connection with such use.

TI has specifically designated certain components as meeting ISO/TS16949 requirements, mainly for automotive use. In any case of use of non-designated products, TI will not be responsible for any failure to meet ISO/TS16949.

Products

Audio	www.ti.com/audio
Amplifiers	amplifier.ti.com
Data Converters	dataconverter.ti.com
DLP® Products	www.dlp.com
DSP	dsp.ti.com
Clocks and Timers	www.ti.com/clocks
Interface	interface.ti.com
Logic	logic.ti.com
Power Mgmt	power.ti.com
Microcontrollers	microcontroller.ti.com
RFID	www.ti-rfid.com
OMAP Applications Processors	www.ti.com/omap
Wireless Connectivity	www.ti.com/wirelessconnectivity

Applications

Automotive and Transportation	www.ti.com/automotive
Communications and Telecom	www.ti.com/communications
Computers and Peripherals	www.ti.com/computers
Consumer Electronics	www.ti.com/consumer-apps
Energy and Lighting	www.ti.com/energy
Industrial	www.ti.com/industrial
Medical	www.ti.com/medical
Security	www.ti.com/security
Space, Avionics and Defense	www.ti.com/space-avionics-defense
Video and Imaging	www.ti.com/video

TI E2E Community

e2e.ti.com